

IS4813 / IS4815 / IS4823 / IS4825

Single-Line Laser Scan Engine

Integration Guide

Disclaimer

Honeywell International Inc. ("HII") reserves the right to make changes in specifications and other information contained in this document without prior notice, and the reader should in all cases consult HII to determine whether any such changes have been made. The information in this publication does not represent a commitment on the part of HII.

HII shall not be liable for technical or editorial errors or omissions contained herein: nor for incidental or consequential damages resulting from the furnishing, performance, or use of this manual.

This document contains propriety information that is protected by copyright. All rights reserved. No part of this document may be photocopied, reproduced, or translated into another language without the prior written consent of HII.

© 2005 - 2012 Honeywell International Inc. All rights reserved.

Web Address: www.honeywellaidc.com

Trademarks

3M is a trademark of 3M and/or its subsidiaries worldwide

Other product names mentioned in this manual may be trademarks or registered trademarks of their respective companies and are the property of their respective owners.

Patents

For patent information, please refer to www.honeywellaidc.com/patents.

Table of Contents

Before Getting Started

Electrostatic Discharge (ESD) Cautions.....	1
Grounding.....	1
Thermal Considerations.....	1
Airborne Contaminants and Foreign Materials	1
Laser Safety	1

Introduction

Product Overview	2
Models and Accessories	
Non-Decode Engines.....	3
Decode Engines.....	3
Labels.....	3
Components of the IS4800 Engine Series	
IS4813 and IS4815 Non-Decode Engine.....	4
IS4823 and IS4825 (-0) Decode Engine Assembly	4
IS4823 and IS4825 Bracketed (-1) Decode Engine Assembly.....	5

Mounting Specifications

IS4813 and IS4815 Scan Engine Dimensions.....	6
IS4823 and IS4825 Bracketed (-1) Dimensions	7
IS4823 and IS4825 (-0) Decode Printed Circuit Board Dimensions	8
Exit Beam Specifications	9
Return Aperture Specifications	10
Enclosure Specifications	
Electrostatic Discharge (ESD) Cautions	11
Grounding	11
Power Supply.....	11
Power Sequencing.....	11
Host Flex Cable	12
Thermal Considerations	12
Printed Circuit Board Component Clearance.....	12
Magnetic Sensitivity	12
Airborne Contaminants and Foreign Materials	12
Exit Laser Beam Clearance.....	13
Return Aperture Clearance	13
Output Window Properties	13
Output Window Coatings	14
Output Window Angle	14

Field of View and Depth of Field.....	17
--	-----------

Timing Diagrams

Startup Condition Timing Diagram	18
Scan Sense Timing Diagram	19

Description Of IS4823 and IS4825 Operating Modes

Activation Modes	20
Common Activation Mode Features	20
Continuous Blinky Mode	21
Sleep Mode	21

Serial Configuration Mode

Abbreviated ASCII Table	23
-------------------------------	----

General Design Specifications

Operational	24
Mechanical	24
Electrical	25
Environmental	25

Detailed Electrical Specifications

Absolute Maximum Ratings	26
IS4823 DC Operating Voltages	26
IS4825 DC Operating Voltages	27
Current Draw @ 25°C	27

Scan Engine Terminations

IS4813 Pinout Connections	28
IS4815 Pinout Connections	28

Decode Printed Circuit Board Terminations

USB Decode PCB, 3.3V	29
USB Decode PCB, 5V	30
TTL, RS232 3.3V / 5V	31

Flex Cable Specifications and Installation Guidelines

Bar Code Element Time Calculation

Regulatory Compliance

Limited Warranty

Index

Customer Support

Technical Assistance	41
Product Service and Repair	41

Before Getting Started*

Note: THIS DEVICE DOES NOT COMPLY WITH 21 CFR 1040. USE ONLY AS A COMPONENT.

The limited warranty (on page 38) is void if the following considerations are not adhered to when integrating an IS4800 series scan engine into a system.

Electrostatic Discharge (ESD) Cautions



ESD has the ability to modify the electrical characteristics of a semiconductor device, possibly degrading or even destroying the device. ESD also has the potential to upset the normal operation of an electronic system, causing equipment malfunction or failure.

The scan engine has exposed electrical components.

- DO NOT touch the leads of the visible laser diode (VLD) or other components.
- ALWAYS use grounding wrist straps and a grounded work area when handling the engine.
- Mount the engine in a housing that is designed for ESD protection and stray electric fields.

Grounding

If the scan engine is to be installed in a grounded host:

- The die-cast engine chassis is at +Vcc. Use an insulator between the engine chassis and host.
- Use non-metallic nylon or equivalent screws.

Thermal Considerations

The IS4800 laser scan engine series is qualified over the specified operational temperatures (0°C to 40°C) for all operating modes. Make sure ambient temperatures do not exceed this range in order to obtain optimal operation. Operating the IS4800 in continuous mode for an extended period may produce considerable heating. This mode should be limited and sufficient airflow should be provided whenever possible to minimize internal heating. Excessive heating may potentially damage the IS4800 engine.

Airborne Contaminants and Foreign Materials

The scan engine has very sensitive miniature electrical and optical components that must be protected from airborne contaminants and foreign materials. In order to prevent permanently damaging the scan engine and voiding the limited warranty (on page 38), the scan engine enclosure must be:

- Sealed to prevent infiltration by airborne contaminants and foreign materials such as dust, dirt, smoke, and smog.
- Sealed to protect against water, humidity and be non-condensing.

Laser Safety

Refer to *Regulatory Compliance* on page 34 for Laser Safety.

* See *Enclosure Specifications* on page 25 for more information.

Introduction

Product Overview

The IS48xx series are miniature laser scan engines. The non-decode IS4813 and IS4815 laser scan engines are designed for direct integration into custom OEM devices equipped with a decoder. The engine's small size is ideal for integration into mobile computers, hand-held scanners, medical/diagnostic equipment, mobile printers, lottery terminals, ATMs and access control devices.

For customer applications requiring integrated decode functionality in addition to solid scan engine performance, the IS4823 and IS4825 models combine the miniature IS4813 and IS4815 engines with a decoder and an optional mounting bracket for a complete small package that provides integration flexibility to meet a variety of OEM applications.

The IS4813 and IS4815 deliver aggressive scanning with a digitized bar/space signal output. The IS4823 and IS4825 provides a decoded output on all standard 1D bar code symbologies — including UPC, EAN, Code 39 and I 2 of 5 — as dense as 4 mil. The IS4823 and IS4825 models support TTL level RS232 or USB system interface. They can operate in standard trigger mode, as well as “blinky” mode for hands-free scanning.

The IS48xx series is equipped with a multitude of features including:

- 100 scan lines per second
- Support for 3.3VDC input voltage (IS4813, IS4823)
- Support for 5VDC input voltage (IS4815, IS4825)
- A 650 nm bright laser diode
- A rugged die cast engine chassis with threaded mounting holes
- An optional mounting bracket for integration flexibility (IS4823, IS4825)
- A 10-pin (IS4813, IS4815) or 12-pin (IS4823, IS4825) ZIF connector with industry standard pinout for seamless integration into portable devices
- Low mass property (see page 24) in an industry standard size
- A wide sweep angle for scanning larger bar codes up close

For ease of integration and optimum engine performance, a Software Development Kit (SDK) for the IS4813 and the IS4815 is available. Contact a customer service representative or sales representative for additional information (see page 41).

Important Notes:

- The manufacturer of the end equipment must register with agencies such as the Food and Drug Administration (FDA). The specifications required for registration are not obtainable until the OEM manufacturer uses the IS4800 series scan engine in its final configuration. Therefore, it becomes the responsibility of the manufacturer who incorporates the scan engine into their product to comply with all federal laser safety regulations. The manufacturer must submit a Laser Product Report for the FDA in the US.
- THIS DEVICE DOES NOT COMPLY WITH 21 CFR 1040. USE ONLY AS A COMPONENT.

Models and Accessories

Non-Decode Engines

Options	
Model	Description
IS4813	Non-Decode, 3.3VDC Scan Engine
IS4815	Non-Decode, 5VDC Scan Engine

Accessories	
Part Number	Description
19-00358	Flex Cable, 10-POS, 67.5 mm Length

Decode Engines

Options	
Base Model	Description
IS4823	3.3VDC Scan Engine with Decode PCB
IS4825	5VDC Scan Engine with Decode PCB
Model and Kit Delineation	
<p>IS482x-yzzz</p>	
<p>x = Input Voltage</p> <p>3 = 3.3VDC</p> <p>5 = 5VDC</p>	<p>zzz = Interface Type</p> <p>103 = TTL, RS232</p> <p>120 = USB</p>
<p>y = Bracket Option</p> <p>0 = No Bracket Supplied</p> <p>1 = Bracket Supplied, Assembled</p>	
<p>Figure 1. IS4823/IS4825 Model and Kit Delineation</p>	

Accessories	
Part Number	Description
19-00329	Flex Cable, 12-POS, 80 mm Length
19-00358	Flex Cable, 10-POS, 67.5 mm Length

Labels

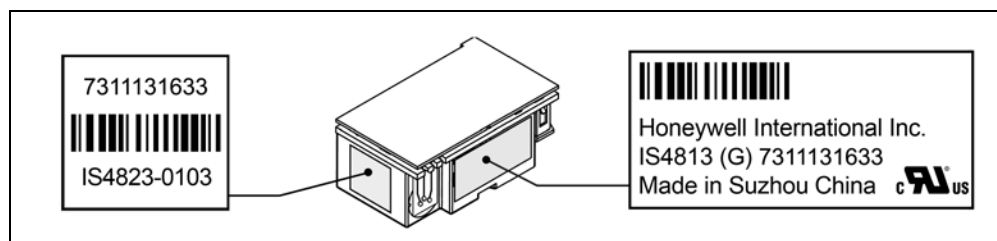

Figure 2. Serial Number Label (Enlarged For Illustration Purposes)

Components of the IS4800 Engine Series

IS4813 and IS4815 Non-Decode Engine



Item	Description	Item Location
1	Pin Locator Holes (see page 6)	
2	Threaded Mounting Points (see page 6)	
3	Exit Beam Location, Laser Light Aperture  AVOID EXPOSURE! – LASER LIGHT IS EMITTED FROM THIS APERTURE.	
4	Flex Cable, 10-POS	
5	ZIF Connector, 10-Pin	
6	Printed Circuit Board and Shield	
7	Die Cast Chassis	

Figure 3. IS4813/IS4815

IS4823 and IS4825 (-0) Decode Engine Assembly

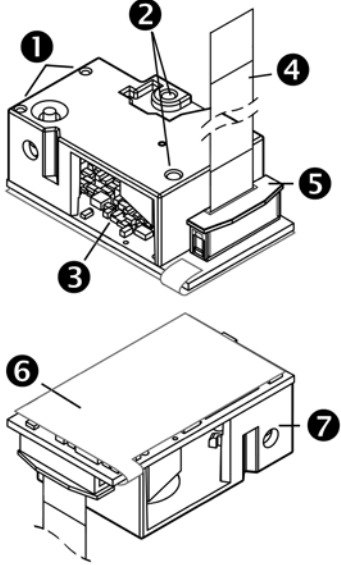

Item	Description	Item Location
1	Decode Printed Circuit Board	
2	ZIF Connector, 12-PIN	
3	Flex Cable, 12-POS	
4	Pin Locator Holes (see page 6)	
5	IS4813 or IS4815 Laser Scan Engine	
6	Exit Beam Location, Laser Light Aperture  AVOID EXPOSURE! – LASER LIGHT IS EMITTED FROM THIS APERTURE.	
7	Threaded Mounting Points (see page 6)	
8	Flex Cable, 10-POS	

Figure 4. IS4823-0/IS4825-0

IS4823 and IS4825 Bracketed (-1) Decode Engine Assembly

Item	Description	Item Location
1	Flex Cable, 12-POS	
2	Flex Cable, 10-POS	
3	ZIF Connector, 10-PIN	
4	Exit Beam Location, Laser Light Aperture  AVOID EXPOSURE! – LASER LIGHT IS EMITTED FROM THIS APERTURE	
5	IS4813 or IS4815 Laser Scan Engine	
6	ZIF Connector, 12-PIN	
7	Decode Printed Circuit Board	
8	0.10 Dia. Clearance Holes for Mounting, 2 Pls.	
9	M2 x 0.4 Threaded Bosses for Mounting, 3 Pls.	
10	Bracket	

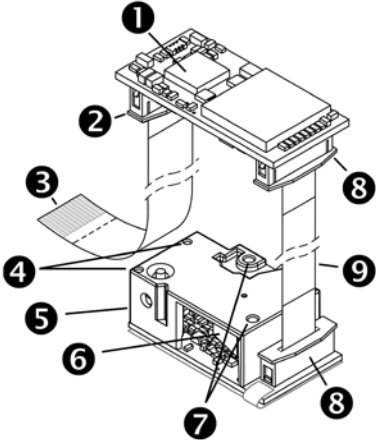
Figure 5. IS4823-1/IS4825-1 Assembled

Mounting Specifications

IS4813 and IS4815 Scan Engine Dimensions

The engine has two M1.6 tapped holes on the bottom of the chassis for mounting the engine with screws. Two additional blind holes are provided on the bottom of the engine for keying purposes to assist with engine alignment (see figure below).

Warning: The limited warranty (on page 38) is void if the following recommendations are not adhered to when mounting the IS4800 series laser scan engine.

Follow the guidelines listed below when securing the engine to non-metallic or metallic mounting surfaces.

For a non-metallic mounting surface:

- Use **non-magnetic** M1.6 x .35 stainless steel screws.
- Do not exceed $1.35 \pm .09$ cm-kg [$1.17 \pm .08$ in-lbs.] of torque during screw installation.
- Use a minimum mount thickness of 3 mm.
- Use safe ESD practices when handling and mounting the engine.

For a metallic mounting surface:

- The die-cast engine chassis is at +Vcc. Use an insulator between the engine chassis and the host (.005" thick PR4, or equivalent).
- Use **non-metallic** nylon or equivalent M1.6 x .35 screws.
- Do not exceeding $1.35 \pm .09$ cm-kg [$1.17 \pm .08$ in-lbs.] of torque.
- Use a minimum mount thickness of 3 mm.
- Use safe ESD practices when handling and mounting the engine.

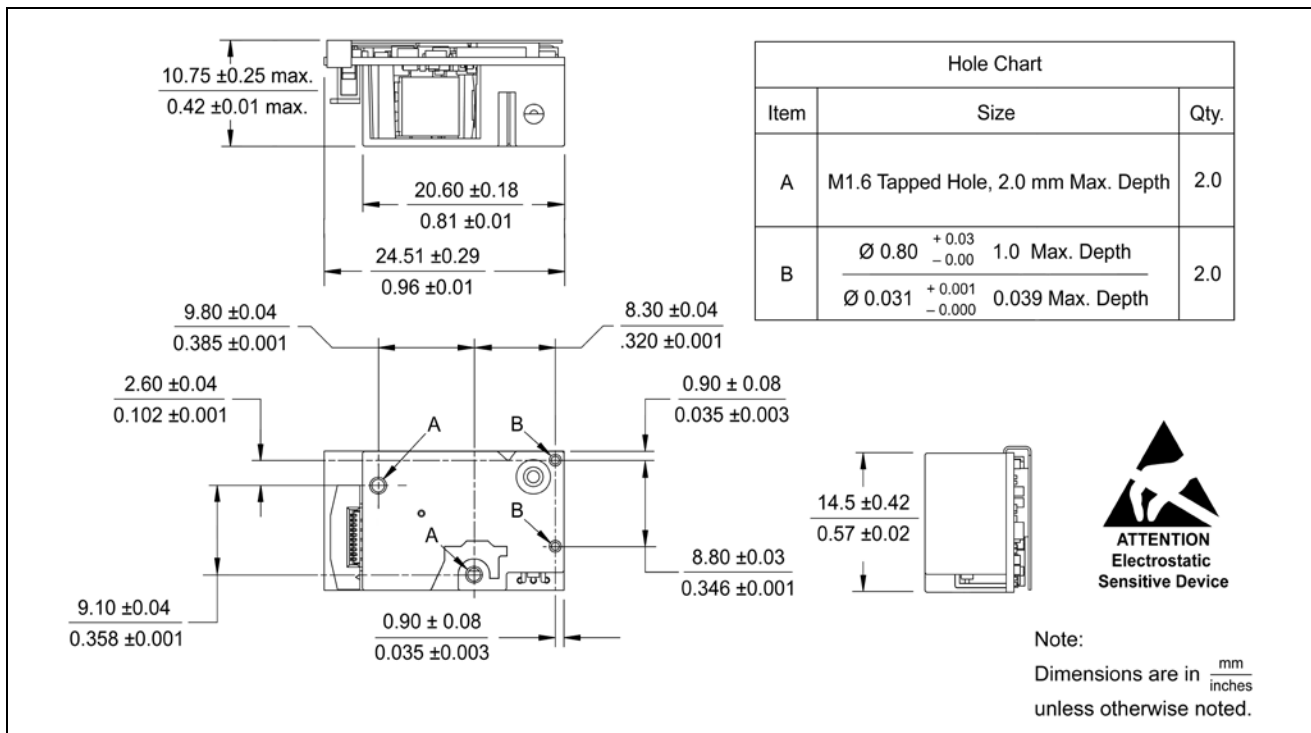

Figure 6. IS4813 and IS4815 Engine Dimensions

Specifications are for reference only and are subject to change without notice.

IS4823 and IS4825 Bracketed (-1) Dimensions

The engine bracket has three M2 x 0.4 threaded inserts on the bottom for mounting the assembly with screws. Two through holes are also provided as an alternative mounting method.

Warning: The limited warranty (on page 38) is void if the following recommendations are not adhered to when mounting the IS4800 series laser scan engine.

When securing the engine by utilizing the three M2 threaded inserts:

- Use M2 x 0.4 Phillips Pan Head, Type AB, Steel, Zinc Clear or equivalent screws.
- Do not exceed 2.88 cm-kg [2.5 in-lb] of torque when securing the engine assembly to the host.
- Use a minimum mount thickness of 3 mm.
- Use safe ESD practices when handling and mounting the engine assembly.

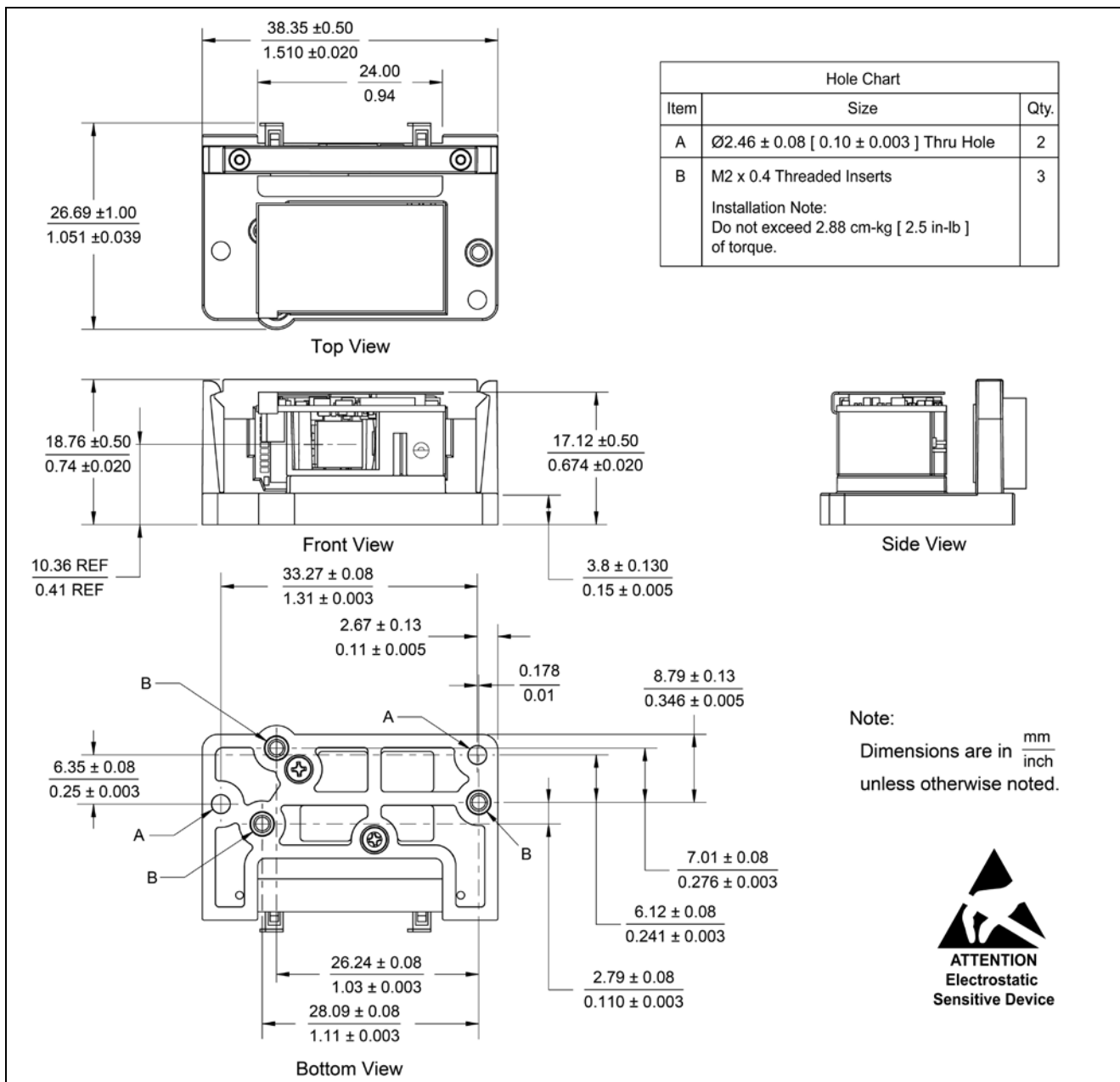

Figure 7. IS4823/IS4825 Bracketed (-1) Dimensions

Specifications are for reference only and are subject to change without notice.

IS4823 and IS4825 (-0) Decode Printed Circuit Board Dimensions

Warning: The limited warranty (on page 38) is void if the following recommendations are not adhered to when mounting the IS4800 series laser scan engine.

When securing the decode board:

- Use 3M™ 4032 1/32" double-coated urethane foam tape (or equivalent).
- Use safe ESD practices when handling and mounting the decode board.

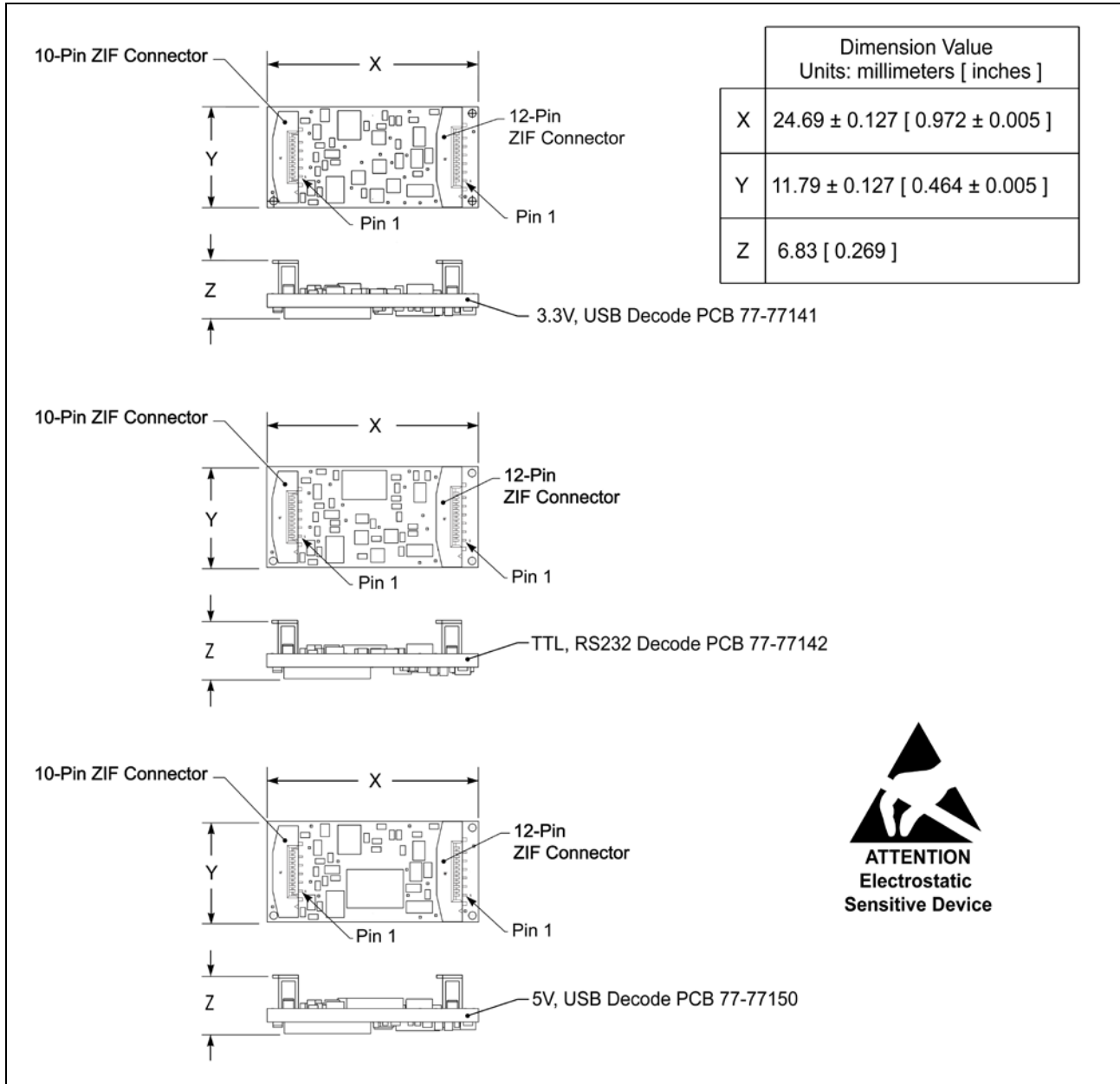

Figure 8. IS4823/IS4825 Decode PCB Dimensions

Specifications are for reference only and are subject to change without notice.

3M is a trademark of 3M and/or its subsidiaries worldwide.

Exit Beam Specifications

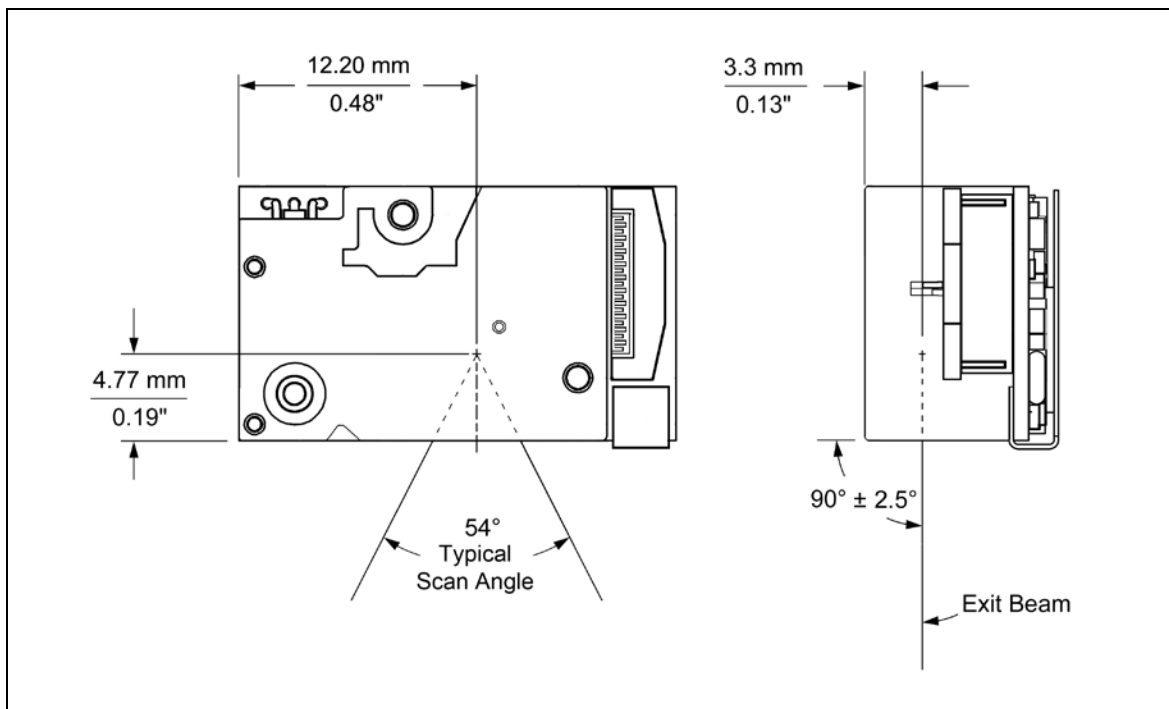

Figure 9. IS4800 Series Exit Beam Specifications

See page see pages 13 - 16 for information on window material specifications and enclosure design considerations.

Specifications are subject to change without notice.

Return Aperture Specifications

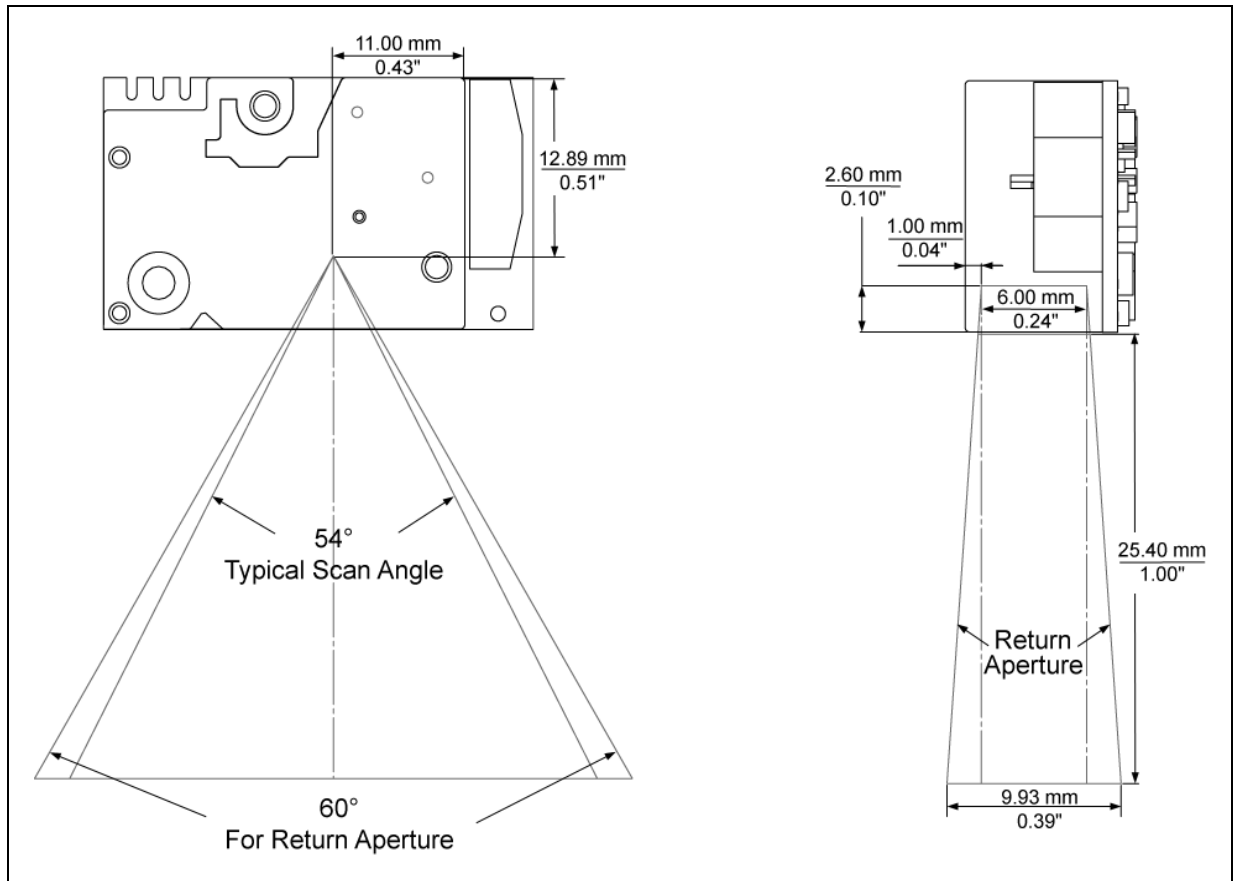

Figure 10. IS4800 Series Return Aperture Specifications

See page see pages 13 - 16 for information on window material specifications and enclosure design considerations.

Specifications are subject to change without notice.

Enclosure Specifications

The IS4800 laser scan engine series was specifically designed for integration into custom housings for OEM applications. The scan engine's performance will be adversely affected or permanently damaged when mounted in an unsuitable enclosure.

Note: THIS DEVICE DOES NOT COMPLY WITH 21 CFR 1040. USE ONLY AS COMPONENT.

The limited warranty (on page 38) is void if the following considerations are not adhered to when integrating an IS4800 series scan engine into a system.

Electrostatic Discharge (ESD) Cautions



ESD has the ability to modify the electrical characteristics of a semiconductor device, possibly degrading or even destroying the device. ESD also has the potential to upset the normal operation of an electronic system, causing equipment malfunction or failure.

The scan engine has exposed electrical components.

- DO NOT touch the leads of the visible laser diode (VLD) or other components.
- ALWAYS use grounding wrist straps and a grounded work area when handling the engine.
- Mount the engine in a housing that is designed for ESD protection and stray electric fields.

Grounding

If the scan engine is to be installed in a grounded host:

- The die-cast engine chassis is at +Vcc. Use an insulator between the engine chassis and host.
- Use non-metallic nylon or equivalent screws.

Power Supply

The IS4813/IS4815 *non-decode* engines are powered from the host device through the 3.3V or 5V and GND pins of the engine's 10-Pin ZIF connector. IS4823/IS4825 *decode* engine assemblies are powered from the host device through the 3.3V or 5V and GND pins of the 12-Pin ZIF connector on the decode board.

This voltage must be maintained within the specified voltage range (see electrical specifications on page 25) at the engine's PCB. Voltage drops in the host flex cable must be taken into account (see *Flex Cables* on page 12).

Power Sequencing[◇]

The IS4813/IS4815 *non-decode* engines are powered from the 3.3V or 5V power signal on the 10-Pin ZIF connector and the IS4823/IS4825 *decode* engine assemblies are powered from the 3.3V or 5V power signal on the decode board. Most of the host signals (signals present on the ZIF connector) are relative to this voltage. Not all of these signals are overvoltage tolerant. Care must be taken to ensure that the relationship between 3.3V or 5V and the host signals are always met (see electrical specifications on page 25).

- ◇ See page 26 - 27 for additional electrical specifications.
See page 29 - 31 for additional pinout information.

Flex Cables[◇]

Note: To ensure optimum engine stability, use the flex cables shipped with the scan engine.

The host flex cable is used to carry power and data signals between the engine and the host system. The flex cable should allow for a minimal voltage drop and maintain a good ground connection between the host and the engine. In terms of grounding and voltage drop, a shorter cable is better. The 10-POS flex cable used to connect the engine to the host or the engine to the decode PCB must be equal to or less than 67.5 mm in length. The 12-POS flex cable used to connect the decode PCB to the host must be equal to or less than 80 mm in length.

In addition to power, the flex cable also carries the digital signals required for communication. The cable design is especially important in USB interface applications due to the relative high speed of the USB signals. The impedance of the cable should match, or be as close as possible to the impedance of the USB driver (approximately 45 ohms per trace).

The routing of the flex cables plays a critical role in the system design. The host flex cable should be routed away from high frequency devices with frequencies that can couple onto the flex cable and cause potential data corruption or unwanted electromagnetic interference (EMI).

Thermal Considerations

The IS4800 laser scan engine series is qualified over the specified operational temperatures (0°C to 40°C) for all operating modes. Ambient temperatures must not exceed this range in order to obtain optimal operation. Operating the IS4800 in continuous mode for an extended period may produce considerable heating. This mode should be limited and sufficient airflow should be provided whenever possible to minimize internal heating. Excessive heating may potentially damage the IS4800 engine.

Printed Circuit Board (PCB) Component Clearance

Warning: When designing the IS4800 into the final product, eliminate all possible dangers of shorting sensitive electronic components in the IS4800 engine. A short could enable the scan engine to emit Class 3R radiation. Any CDRH filing will require a disclosure of the design ensuring a method to mitigate a potential short.

Magnetic Sensitivity

The scan engine can be negatively affected by magnetic fields:

- Use only non-magnetic screws and locating pins.
- Do not mount the engine within 1.00" (25.4 mm) of any magnetic materials.

Airborne Contaminants and Foreign Materials

The scan engine has very sensitive miniature electrical and optical components that must be protected from airborne contaminants and foreign materials. In order to prevent permanently damaging the scan engine and voiding the limited warranty (on page 38), the scan engine enclosure must be:

- Sealed to prevent infiltration by airborne contaminants and foreign materials such as dust, dirt, smoke, and smog.
- Sealed to protect against water, humidity and be non-condensing.

◇ See page 26 - 27 for additional electrical specifications.
See page 29 - 31 for additional pinout information.

Exit Laser Beam Clearance

- Keep the scan engine's beam sweep free from obstructions. For detailed information on the exit beam angle and location, please refer to *Exit Beam Specifications* on page 9.
- A dark matte-finish on the internal walls of the housing can be utilized to avoid internal beam reflections.

Return Aperture Clearance

- Refer to *Return Aperture Clearance* on page 10 for requirements for return aperture clearance and ensure no obstructions in the paths of exit laser beam and return signal.

Output Window Properties

Note: Contact a customer service representative to coordinate the best window material required to maintain laser safety requirements for your application.

An improperly placed window has the serious potential to reduce the scan engine's performance. Careful consideration must be made when designing the output window's distance and angle placement relative to the scan engine's exit beam and chassis.

Follow these guidelines when designing the output window.

- Acceptable window materials include; Acrylic (cast or molded), float glass, CR-39, and Polycarbonate.
Note: *Molded polycarbonate is high in strength; however, it might exhibit a phenomenon called birefringence. Birefringence refers to multiple indices of refraction within one material. This condition will induce polarization effects that can be detrimental to scan performance of the engine. Check with a representative before utilizing a transparent polycarbonate material for the output window.*
- The exit window material must have a spectral transmission of at least 85% from 640 nm to 690 nm and should block shorter wavelengths.
- Red cell-cast acrylic is recommended.
- The exit window must exhibit a wavefront distortion (transmission) of no more than 0.2 wavelengths peak-to-valley maximum over any 0.08" diameter within the clear aperture.
- The clear aperture of the output window must extend beyond the 54° beam sweep (see *Exit Beam Specifications* on page 9).
- It must have a 60-40 surface quality and be optically flat, clear, and free of scratches, pits, or seeds. If possible, recess the window into the housing for protection or apply a scratch resistance coating (see *Output Window Coatings* on page 14).
- Apply an anti-reflective coating to the window surfaces to reduce the possibility of reflective light interfering with the engine's performance due to the window angle (see *Output Window Coatings* on page 14).

Output Window Coatings

- **Anti-Reflection**
An anti-reflective coating can be applied to the inside and/or outside of the window to reduce the possibility of internal beam reflections interfering with the scan performance of the engine. If an anti-reflective coating is applied, it is recommended that it be on both sides of the window providing a 0.5% maximum reflectivity on each side from 640 to 690 nanometers at the nominal window tilt angle. The coating must also meet the hardness adherence requirements of MIL-M-13508.
- **Polysiloxane Coating**
Apply a polysiloxane coating to the window surface to help protect the window from surface scratches and abrasions that may interfere with the scan performance of the engine. Recessing the window into the housing can also provide added protection against surface damage such as scratches and chips. If an anti-reflective coating is used, there is no need to apply a polysiloxane coating.

Output Window Angle

Note: *An improperly placed window has the serious potential to reduce the scan engine's performance. Careful consideration must be made when designing the output window's distance and angle placement relative to the scan engine's exit beam and chassis.*

It is important that angle of the window not be perpendicular to the exit beam of the scan engine. The angle of the window can cause the beam's laser light to reflect off the inside of the window back into the scan engine's optics ultimately degrading the engine's performance.

Refer to the *Figure 11* on page 15 and *Figure 12* on page 16 for specifications on the minimum allowable window angle required to avoid reflective beam interference.

**Minimum Allowable Window Angle Required
To Avoid Detrimental Internal Reflective Beam Interference
(at Positive Exit Beam Angle Tolerance)**

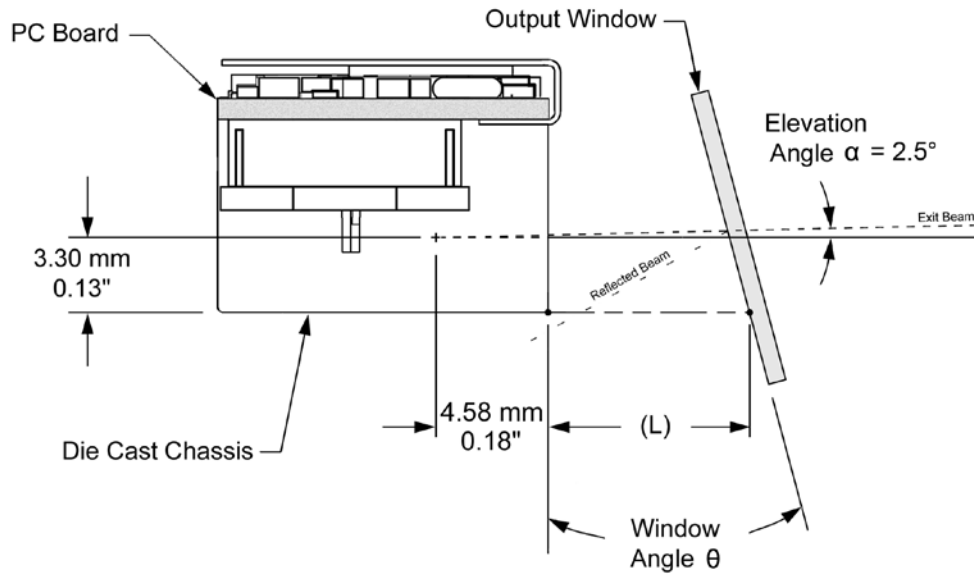

Minimum Projected Distance (mm) from the Engine's Base to the Window's Internal Surface (L)	Minimum Window Angle θ
5.0	28.0°
10.0	14.5°
15.0	10.5°
20.0	8.0°
25.0	7.0°
30.0	6.5°
35.0	6.0°
40.0	5.5°
45.0	5.0°
50.0	5.0°

Figure 11.

Specifications are subject to change without notice.

**Minimum Allowable Window Angle Required
To Avoid Detrimental Internal Reflective Beam Interference
(at Negative Exit Beam Angle Tolerance)**

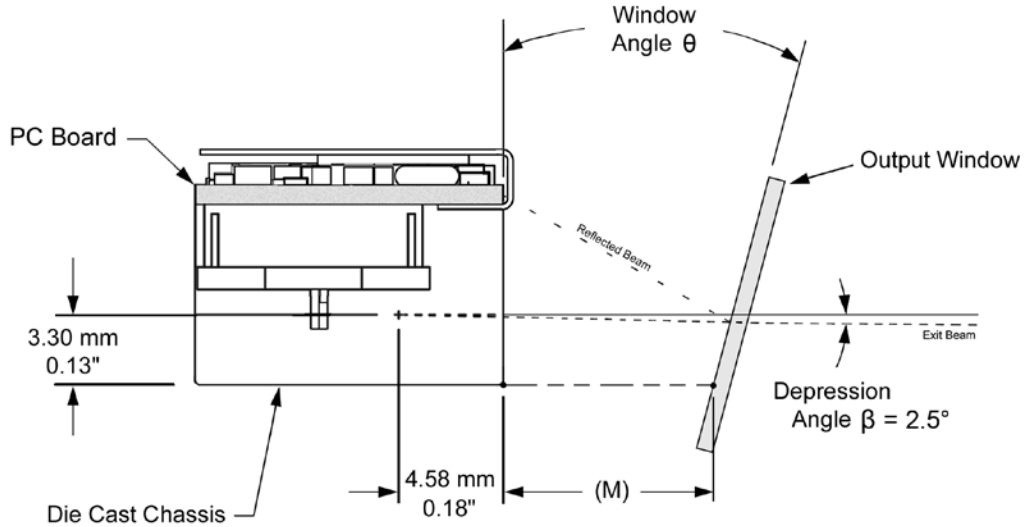

Minimum Projected Distance (mm) from the Engine's Base to the Window's Internal Surface (M)	Minimum Window Angle θ
5.0	23.5°
10.0	16.5°
15.0	12.5°
20.0	10.5°
25.0	9.0°
30.0	8.0°
35.0	7.5°
40.0	7.0°
45.0	6.5°
50.0	6.0°

Figure 12.

Specifications are subject to change without notice.

Scan Engine Field of View and Depth of Field

Field of View

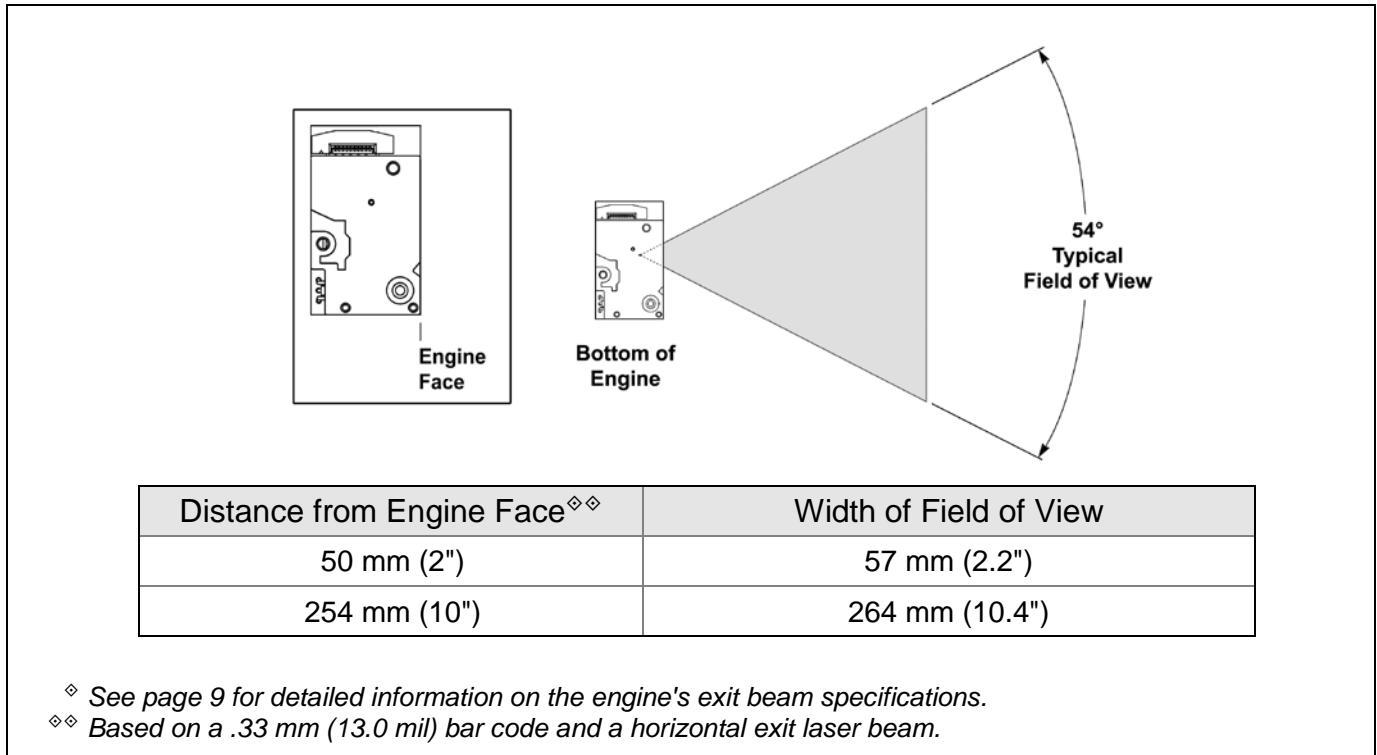

Figure 13. Typical Field of View

Depth of Field vs. Minimum Bar Code Element

Bar Code Element Width	Depth of Field* (In the Field of View)			
	Start (From Engine Face)	End (From Engine Face)	Total	
1D	.13 mm 5.2 mil	70 mm (2.75")	95 mm (3.75")	25 mm (1.00")
	.19 mm 7.5 mil	57 mm (2.25")	171 mm (6.75")	114 mm (4.50")
	.26 mm 10.4 mil	50 mm (2.00")	210 mm (8.25")	160 mm (6.25")
	.33 mm 13.0 mil	50 mm (2.00")	254 mm (10.00")	204 mm (8.00")
	.49 mm 19.5 mil	75 mm (2.95")	300 mm (11.81")	225 mm (8.86")

* For non-decode IS4813 and IS4815 engines, depth of field data is for reference only. Actual values may vary depending on environmental conditions, host hardware, and decoding software.

Depth of field data was measured at 25°C under typical indoor lighting. Performance may vary depending on testing conditions.

Specifications are subject to change without notice.

Timing Diagrams

Startup Condition Timing Diagram

The timing diagram below illustrates the correct power up procedure for the IS4813 and IS4815 engines.

Scan Enable and Laser Enable are host driven signals. The Scan Enable and Laser Enable signals should be kept LOW (ON) at power up. Scan Control and Laser Control are engine driven signals.

The engine's onboard microcontroller drives the Scan Control and Laser Control signals so the engine's laser will not turn ON before the scan mirror starts moving. This allows the onboard microcontroller to sense immediately any malfunction with the engine's scan mirror, turning OFF the laser automatically regardless of the state of Laser Enable signal being received from the Host.

To ensure scan data integrity the Scan Sense pulses are delayed for approximately 51 ms after the Laser Enable signal goes LOW (ON). To save power, turn OFF power to the engine after the scan is complete or when the engine is not scanning. To turn the engine's power OFF, the Laser Enable signal from the host should be held HIGH (OFF) before turning OFF power to the engine.

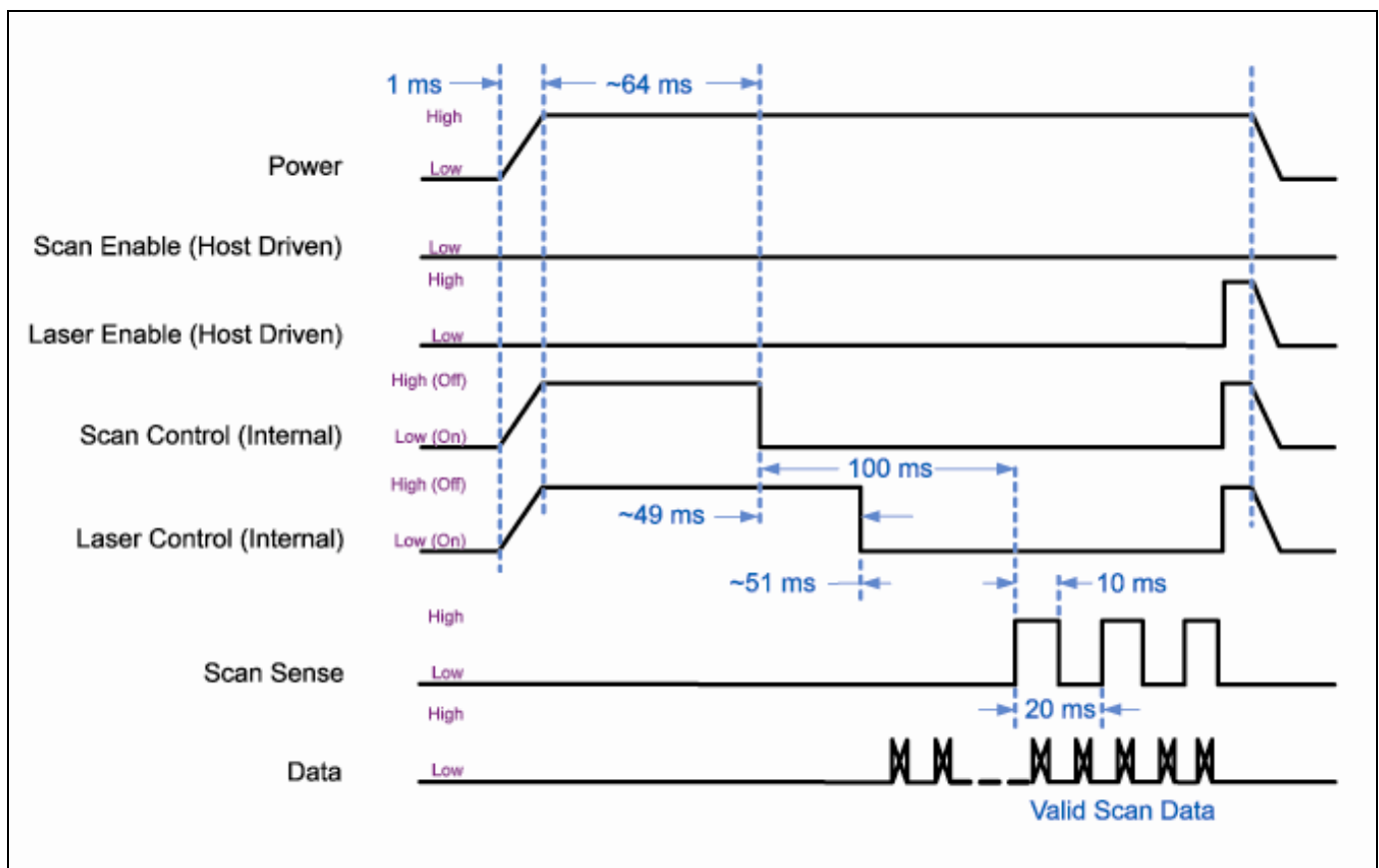

Figure 14. IS4813/IS4815 Timing Diagram, Startup Condition*

* Typical timing for reference only, not to scale. Actual timing may vary.

Scan Sense Timing Diagram

The Scan Sense signal is a 50% duty cycle square wave with the transitions from HIGH to LOW indicating a change in the scan direction of the scanning beam (see Figure 14). Valid scan data occurs between the HIGH to LOW transitions. Figure 15 illustrates the condition in which power to the engine stays ON. Scan Enable and Laser Enable signals are controlled separately by the host.

The onboard microcontroller is programmed to ensure the engine's scan mirror is moving before the laser is turned ON. This allows the host to turn ON Scan Enable and Laser Enable signals simultaneously without worrying about laser safety. The Laser Enable signal can even be set LOW (ON) before the Scan Enable signal goes LOW (ON). If the scan mirror is moving and Laser Enable signal goes LOW (ON), the onboard microcontroller immediately turns ON the laser. If Laser Enable signal is LOW (ON) and Scan Enable signal is HIGH (OFF) then the onboard microcontroller waits for the Scan Enable signal to go LOW (ON) and ensures the scan mirror has started moving before turning the laser ON.

The Scan Sense line remains HIGH until the Scan Enable signal goes LOW (ON). After approximately 100 ms, it toggles with a 50% duty cycle representing the scan sweep direction. Valid scan data appears within these pulses.

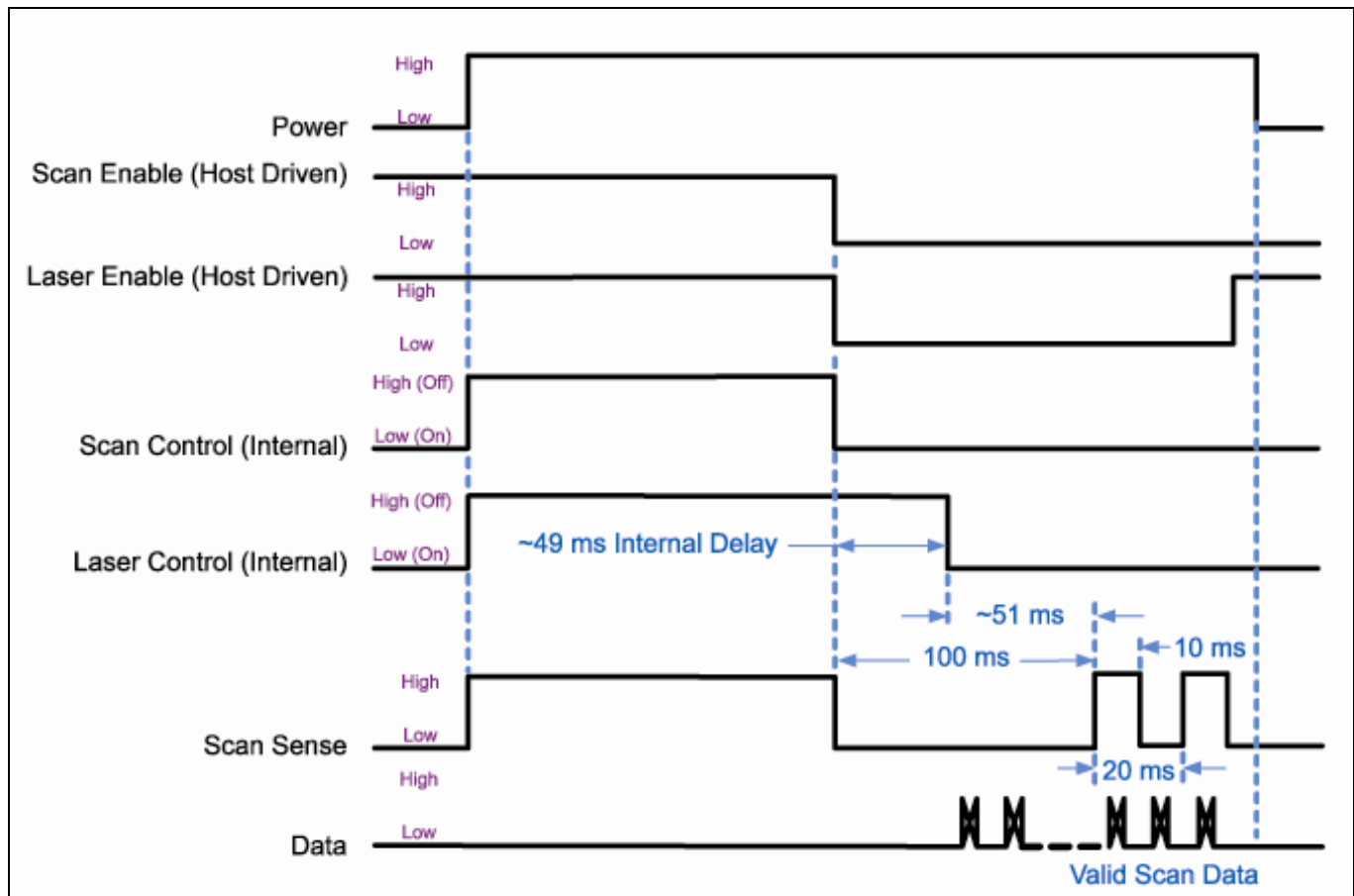

Figure 15. Timing Diagram Scan Enable and Laser Enable Controlled Separately*

* Typical timing for reference only, not to scale. Actual timing may vary.

Descriptions of IS4823 and IS4825 Operating Modes

Activation Modes

The following activation modes initiate the engine's laser and motor drive circuitry for bar code scanning.

Activate Scanning with the External Trigger (Default).

An external I/O pin is used to enable the scanning cycle. A High-to-Low transition on the I/O signal is used to activate scanning. The signal must be deactivated (HIGH) and re-activated for subsequent scanning cycles. The scanning cycle is terminated based on the default period of time (2 seconds), a variable period of time, when the I/O signal is deactivated (Low-to-High), or when a bar code is scanned and transmitted.

Activate Scanning on Receipt of the <DC2> Character

A received <DC2> character initiates the scanning cycle. The scanning cycle is terminated based on the default period of time (2 seconds), variable laser timeout selected, receipt of <D4> character, or when a bar code is scanned and transmitted.

Activate/Deactivate Scanning Using D/E

A received 'E' character initiates the scanning cycle. The scanning cycle is terminated based on the default period of time (2 seconds), variable laser timeout selected, or receipt of a 'D' or when a bar code is scanned and transmitted.

Activate Scanning with Address

A configurable address character is used to initiate scanning. The scanning cycle is terminated based on the default period of time (2 seconds), variable laser timeout selected, or when a bar code is scanned and transmitted.

Common Activation Mode Features

The following configurable activation mode features are available for the IS4823 and IS4825.

Variable Laser-On Timeout (1-second Increments)

A configurable time increment selected as the scanning laser-on time.

Allow Full Laser-On Cycle

The laser stays on for a full cycle even when a bar code is scanned and transmitted.

Blinky Mode

The scanner will blink for 60 cycles (approximately 30 seconds) once the scanning cycle is activated.

Transmit “NO READ” Message on Laser Timeout

If the scanning cycle terminates without scanning a bar code during the cycle, a “NO READ” message is transmitted with the termination of the scanning cycle.

Activate the LED Signal During the “NO READ” Transmission

The LED signal is activated with the “NO READ” message. The LED signal is also activated after a successful scan.

Enable RTS “NO READ” Pulse

A configurable RTS pulse width transmitted after the “NO READ” message has been transmitted.

Detect and Notify Mode

The external I/O pin used in the default activation mode is monitored during the inactive laser cycles. An <SI> is transmitted when the I/O is active and an <SO> when it is inactive. Once the scanning activation cycle is started, the external I/O monitoring status is maintained until the scanning cycle is terminated regardless of the actual I/O level.

Continuous Blinky Mode

The scanner will continuously blink on and off, turning the scanning cycle on and off for all normal scanner operations. If a bar code is scanned and transmitted, the same symbol timeout is maintained throughout the cycle preventing additional scans of the same bar code when the scanner is in default mode.

Sleep Mode

Sleep Mode is a power saving mode that can be configured to occur in 1-second increments.

Serial Configuration Mode

The IS4823/IS4825 can be configured by scanning configuration bar codes[†] or by serial commands sent from the host device. With serial configuration, each command sent to the engine is the ASCII representation of each numeral in the configuration bar code (see Figure 16). The entire numeric string is framed with an ASCII [stx] and an ASCII [etx].



Figure 16.

Example 1:

<u>Feature</u>	<u>Host Command</u>	<u>String Sent to the Engine - ASCII Representation (Hexadecimal Values)</u>
Disable Codabar	[stx]100104[etx]	02h 31h 30h 30h 31h 30h 34h 03h

[ack]

If the command sent to the engine is valid, the engine will respond with an [ack].

[nak]

If the command sent to the engine is invalid, the engine will respond with a [nak] then automatically exit serial configuration mode. All the settings chosen in the failed serial configuration session will be lost. There is a 20-second window between commands. If a 60-second timeout occurs, the engine will send a [nak].

Enter Serial Configuration Mode

To enter serial configuration mode, send the following command, [stx]999999[etx]. The engine will not scan bar codes while in serial configuration mode.

Note: Serial configuration mode uses the current Baud Rate, Parity, Stop Bits and Data Bits settings that are configured in the engine. The default settings of the engine are 9600 bits-per-second, space parity, 2 stop bits, 7 data bits, and no flow control. If a command is sent to the engine to change any of these settings, the change will not take effect until after serial configuration mode is exited.

Exit Serial Configuration Mode

To exit serial configuration mode, send the following command, [stx]999999[etx]. The engine will respond with an [ack].

[†] Configuration bar codes are located in the MetroSelect Single-Line Guide, PN 00-02544 and the Supplemental MetroSelect Configuration Guide, PN 00-05268.

Example 2:

The following sample illustrates the serial command sequence for configuring the engine for the factory default settings, disabling Code 128 scanning, and adding a "G" as a configurable prefix.

Commands for features that require sequences of multiple bar codes for activation (i.e. prefixes, suffixes, and timeout features) should be sent in the same order that they are normally scanned.

<u>Feature</u>	<u>Host Command</u>	<u>ASCII Representation</u>	<u>Engine Response</u>
Enter Configuration Mode	[stx]999999[etx]	02h 39h 39h 39h 39h 39h 39h 03h	[ack] or 06h
Load Defaults	[stx]999998[etx]	02h 39h 39h 39h 39h 39h 38h 03h	[ack] or 06h
Disable Code 128	[stx]100103[etx]	02h 31h 30h 30h 31h 30h 33h 03h	[ack] or 06h
Configure Prefix #1	[stx]903500[etx]	02h 39h 30h 33h 35h 30h 30h 03h	[ack] or 06h
Code Byte 0	[stx]0[etx]	02h 30h 03h	[ack] or 06h
Code Byte 7	[stx]7[etx]	02h 37h 03h	[ack] or 06h
Code Byte 1	[stx]1[etx]	02h 31h 03h	[ack] or 06h
Exit Configuration Mode	[stx]999999[etx]	02h 39h 39h 39h 39h 39h 39h 03h	[ack] or 06h

Abbreviated ASCII Table

Character	Hex Value	Decimal Value
[STX]	02h	2
[ETX]	03h	3
[ACK]	06h	6
[NAK]	15h	21
0	30h	48
1	31h	49
2	32h	50
3	33h	51
4	34h	52
5	35h	53
6	36h	54
7	37h	55
8	38h	56
9	39h	57

General Design Specifications

Operational

Light Source:	Visible Laser Diode (VLD) @ 650 nm	
Laser Power:	1 mW	
Depth of Scan Field:	50 mm – 254 mm (2" – 10") for 0.33 mm (13 mil) bar codes	
Width of Scan Field:	57 mm (2.2") @ 50 mm (2") from engine face	
	264 mm (10.4") @ 254 mm (10") from engine face	
Scan Speed:	100 Scan Lines per Second Typical	
Scan Pattern:	Single Scan Line	
Minimum Bar Width:	0.10 mm (4.0 mil)	
Symbologies Supported:	IS4813 and IS4815	Decoder Dependent
	IS4823 and IS4825	Autodiscriminates All Standard 1D Symbologies, including GS1 DataBar
System Interface:	IS4823 and IS4825	USB, TTL RS232
Print Contrast:	35% Minimum Reflectance Difference	
Number of Characters Read:	IS4813 and IS4815	Decoder Dependent
	IS4823 and IS4825	Up to 80 data characters (Maximum)
Roll, Pitch, Yaw	42°, 68°, 52°	

Mechanical

Dimensions:	See pages 6 – 8 for detailed specifications.	
Weight (Maximum):	IS4813 / IS4815 Non-Decode Engine	8 g (0.282 oz)
	IS4823 / IS4825 Bracketed (-1) Assembly	15 g (0.529 oz)
	IS4823 / IS4825 Non-Bracketed (-1) Assembly	10 g (0.353 oz)
Termination:	IS4813 / IS4815 Non-Decode Engine	10-PIN ZIF Connector
	IS4823 / IS4825 Decode PCB	12-PIN ZIF Connector
Enclosure and Mounting:	See pages 6 – 14 for detailed specifications on enclosure and mounting guidelines.	

Specifications are subject to change without notice.

Electrical

	IS4813	IS4815
Input Voltage:	3.3VDC \pm 0.3VDC	5.0VDC \pm 5%
Power Consumption:	400 mW	350 mW
Typical Operating Current:	< 120 mA @ 3.3VDC	< 70 mA @ 5.0VDC
Peak Operating Current*:	< 300 mA @ 3.3VDC	< 200 mA @ 5.0VDC
Standby Current:	< 30 mA @ 3.3VDC	< 15 mA @ 5.0VDC

	IS4823		IS4825	
	USB	TTL	USB	TTL, RS232
Peak Operating Current*:	270 mA	220 mA	165 mA	135 mA
Idle Current:	75 mA	50 mA	72 mA	45 mA
Sleep Current:	65 mA	5.5 mA	53 mA	15 mA
Suspend Current (USB):	5.5 mA	N/A	0.30 mA	N/A
Power Down Current (TTL):		5.5 mA		15 mA

See pages 34 - 37 for regulatory compliance information.

* Peak Operating Current is the highest current drawn seen during normal operation. It does not include in-rush current which is an exceptional current spike seen only once during initial powering up of the engine.

Environmental

Operating Temperature:	0°C to 40°C (32°F to 104°F)
Storage Temperature:	-40°C to 70°C (-40°F to 158°F)
Humidity:	5% to 95% relative humidity, non-condensing
Vibration Protection:	7G over 10 – 500 Hz
Drop Protection:	2000G at a duration of 0.85 msec
EMI:	Designed to meet EN55022 Radiated Class B emission limits

Specifications are subject to change without notice.

Detailed Electrical Specifications

Absolute Maximum Ratings

Signal	Signal Description	Minimum	Maximum
Vinput [†]	Voltage Applied to Any input pin (except D+ and D-) *	-0.3V	Vin
Voutput	Voltage Applied to Any output pin **	-0.3V	Vin + 0.3V

* For USB version, Voltages on D+ and D- signal must conform to USB Specification

** Voutput must be less than 5.5V for all pins

† If the Vinput signal is greater than VIN, current will flow from the input to the VIN pin through the pull up resistors on the engine. In Suspend Mode, this may cause current to flow into the USB power. This is not recommended.

IS4823 DC Operating Voltages

Signal	Signal Description	Minimum	Maximum	Condition
VIN	Operating Voltage	3.0V	3.6V	
VIH(1)	Input High (RX, CTS)	2.5V		
VIL(1)	Input Low (RX, CTS)		0.8V	
VIH(2)	Input High (TTL_INV, nWake)	0.8 x Vin		
VIL(2)	Input Low (TTL_INV, nWake)		0.8V	
VIH(3)	Input High (EXT. Trigger)	0.8 x Vin		
VIL(3)	Input Low (EXT. Trigger)		0.8V	
VOH(1)	Output High Voltage (TX,RTS)	0.8 x Vin		Isource = 16 mA
VOL(1)	Output Low Voltage (TX,RTS)		0.14 x Vin	Isink = 16 mA
VOH(2)	Output High Voltage (nBeeper, nGoodRead)	***	3.6V	
VOL(2)	Output Low Voltage (nBeeper, nGoodRead)		1.6V	Isink = 25 mA
VOH(3)	Output High Voltage (Power down)	***	3.6V	
VOL(3)	Output Low Voltage (Power down)		0.2V	Isink = 8 mA

*** PWRDWN, nGoodRead, and nBeeper are open drain outputs w/ 100K pull-ups to VIN. Actual VOH will be determined by the parallel resistance of the 100K pull up and any external impedance.

IS4825 DC Operating Voltages

Signal	Signal Description	Minimum	Maximum	Condition
VIN	Operating Voltage	4.75V	5.25V	
VIH(1)	Input High (RX, CTS)	2.5V		
VIL(1)	Input Low (RX, CTS)		0.8V	
VIH(2)	Input High (TTL_INV, nWake)	0.8 x Vin		
VIL(2)	Input Low (TTL_INV, nWake)		0.8V	
VIH(3)	Input High (EXT. Trigger)	0.8 x Vin		
VIL(3)	Input Low (EXT. Trigger)		0.8V	
VOH(1)	Output High Voltage (TX,RTS)	0.8 x Vin		Isource = 16 mA
VOL(1)	Output Low Voltage (TX,RTS)		0.14 x Vin	Isink = 16 mA
VOH(2)	Output High Voltage (nBeeper, nGoodRead)	***	3.6V or 5.5V	
VOL(2)	Output Low Voltage (nBeeper, nGoodRead)		1.6V	Isink = 25 mA
VOH(3)	Output High Voltage (Power down)	***	3.6V or 5.5V	
VOL(3)	Output Low Voltage (Power down)		0.2V	Isink = 8 mA

*** PWRDWN, nGoodRead, and nBeeper are open drain outputs w/ 100K pull-ups to VIN. Actual VOH will be determined by the parallel resistance of the 100K pull up and any external impedance.

Current Draw @ 25°C

Signal	Signal Description	USB		TTL	
		VIN = 3.3V	VIN = 5V	VIN = 3.3V	VIN = 5V
Continuous Scan mode	Average current draw during continuous scan mode*	150 mA	130 mA	130 mA	130 mA
Stand By	Average current draw while in idle mode**	60 mA	72 mA	50 mA	45 mA
Sleep	Average current draw while in sleep mode**	50 mA	53 mA	5.5 mA	15 mA
Suspend Mode (USB)	Average current draw in USB suspend (USB version only)	5.5 mA	0.3 mA	N/A	N/A

* Continuous Scan Mode current will vary based on object size, distance, and type. The numbers listed above are typical.

**To conserve power for battery operated devices, Honeywell recommends using a power switch to operate the scan engine.

Scan Engine Terminations

IS4813 Engine Connections

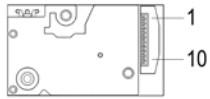
10-Pin ZIF Connector			
 <p>Figure 17. IS4813</p>	Pin	Signal Name	Function
	1	No Connect	No Connect
	2	Power, V_{CC}	$3.3V \pm 0.3V$
	3	No Connect	No Connect
	4	Laser Enable*	High = Laser OFF Low = Laser ON, only if pin 5 (scan enable) is also Low
	5	Scan Enable*	High = Engine OFF Low = Engine ON
	6	Digitized Bar Pattern, Data Out	High = Bar Low = Space
	7	Start of Scan, Scan Sense	Level changes from high to low, or low to high, when the laser changes direction at the start of the scan line.
	8 and 9	Ground	Power Ground
	10	No Connect	No Connect

IS4815 Engine Connections

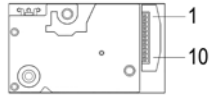
10-Pin ZIF Connector			
 <p>Figure 18. IS4815</p>	Pin	Signal Name	Function
	1	No Connect	No Connect
	2	Power, V_{CC}	$5.0V \pm 5\%$
	3	No Connect	No Connect
	4	Laser Enable*	High = Laser OFF Low = Laser ON, only if pin 5 (scan enable) is also Low
	5	Scan Enable*	High = Engine OFF Low = Engine ON
	6	Digitized Bar Pattern, Data Out	High = Bar Low = Space
	7	Start of Scan, Scan Sense	Level changes from high to low, or low to high, when the laser changes direction at the start of the scan line.
	8 and 9	Ground	Power Ground
	10	No Connect	No Connect

* See Timing Diagrams on page 33.

Decode Printed Circuit Board Terminations

USB Decode PCB, 3.3V

		12-Pin ZIF Connector	
Pin	Signal Name	Function	
1	No Connect	No Connection	
2	+3.3V	Power: Supply Voltage Input, +3.3V ± 0.3V	
3	GND	Ground: Power and Signal Ground	
4	D-	Input: USB D- Signal	
5	<reserved>	Pin Function Reserved	
6	D+	Input: USB D+ Signal	
7	<reserved>	Pin Function Reserved	
8	PWRDWN	Output: Active High = IS4823 is in Power Down Mode	
9	nBEEPER	Output: Active Low, Signal Capable of Sinking Current See <i>Detailed Electrical Specifications</i> starting on page 26.	
10	nGood Scan	Output: Active Low, Signal for Sinking Current (Good Scan) See <i>Detailed Electrical Specifications</i> starting on page 26.	
11	nEXT Wake	Input: Active Low, Wakes Engine From Suspend or Sleep Mode	
12	nEXT Trig	Input: Active Low, Signal Used as Trigger Input to Activate the Engine	
		10-Pin ZIF Connector	
Pin	Signal Name	Function	
1	SDA	I ² C Data (Bi-Directional) – Devices Function as Auxiliary Devices	
2	GND	Ground: Power and Signal Ground	
3	GND	Ground: Power and Signal Ground	
4	Scan Sense	Level changes from High to low or low to high when the laser changes direction at the start of the scan line	
5	Data	High = Bar	
		Low = Space	
6	Scan Enable	High = Engine OFF	
		Low = Engine ON	
7	Laser Enable	High = Laser OFF	
		Low = Laser ON	
8	NC	No Connection	
9	+3.3V	Power: Supply Voltage Output, +3.3V ± 0.3V	
10	SCL	I ² C Data (Bi-Directional) – Devices Function as Auxiliary Devices	

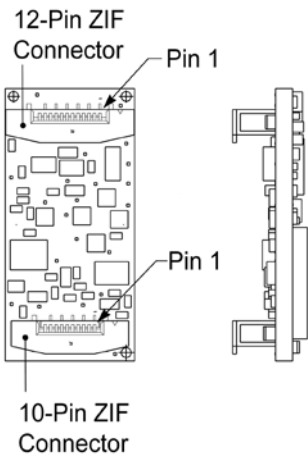

Figure 19.

USB Decode PCB, 5V

		12-Pin ZIF Connector	
Pin	Signal Name	Function	
1	No Connect	No Connection	
2	+5.0V	Power: Supply Voltage Input, +5.0V ± 5%	
3	GND	Ground: Power and Signal Ground	
4	D-	Input: USB D- Signal	
5	<reserved>	Pin Function Reserved	
6	D+	Input: USB D+ Signal	
7	<reserved>	Pin Function Reserved	
8	PWRDWN	Output: Active High = Engine is in Power Down Mode	
9	nBEEPER	Output: Active Low, Signal Capable of Sinking Current See <i>Detailed Electrical Specifications</i> starting on page 26.	
10	nGood Scan	Output: Active Low, Signal for Sinking Current (Good Scan) See <i>Detailed Electrical Specifications</i> starting on page 26.	
11	nEXT Wake	Input: Active Low, Wakes Engine from Power Down or Sleep Mode	
12	EXT Trig	Input: Active Low, Signal Used as Trigger Input to Activate the Engine	
		10-Pin ZIF Connector	
Pin	Signal Name	Function	
1	SDA	I ² C Data (Bi-Directional) – Devices Function as Auxiliary Devices	
2	GND	Ground: Power and Signal Ground	
3	GND	Ground: Power and Signal Ground	
4	Scan Sense	Level changes from High to low or low to high when the laser changes direction at the start of the scan line	
5	Data	High = Bar	
		Low = Space	
6	Scan Enable	High = Engine OFF	
		Low = Engine ON	
7	Laser Enable	High = Laser OFF	
		Low = Laser ON	
8	NC	No Connection	
9	+5.0V	Power: Supply Voltage Output, +5.0V ± 5%	
10	SCL	I ² C Data (Bi-Directional) – Devices Function as Auxiliary Devices	

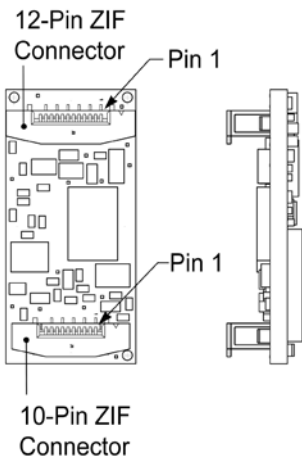

Figure 20.

TTL, RS232, 3.3V / 5V

		12-Pin ZIF Connector		
Pin	Signal Name	Function		
1	TTLINV	Input: TTL RS232 Polarity Control with 33.2k ohm Pull-Up		
2	+3.3V or 5.0V	Power: Supply Voltage Input, +3.3V \pm 0.3V or +5.0V \pm 5%		
3	GND	Ground: Power and Signal Ground		
4	RxD	Input: TTL Level RS232 Receive Data		
5	TxD	Output: TTL Level RS232 Transmit Data		
6	CTS	Input: TTL Level Clear to Send		
7	RTS	Output: TTL Level RS232 Request to Send		
8	PWRDWN	Output: Active High = IS4823 is in Power Down Mode		
9	nBEEPER	Output: Active Low, Signal Capable of Sinking Current See <i>Detailed Electrical Specifications</i> starting on page 26.		
10	nGood Scan	Output: Active Low, Signal for Sinking Current (Good Scan) See <i>Detailed Electrical Specifications</i> starting on page 26.		
11	nEXT WAKE	Input: Active Low, Signal Used to Bring Engine Out of Power Down		
12	nEXT Trig	Input: Active Low, Signal Used as Trigger Input to Activate the Engine		
		10-Pin ZIF Connector		
Pin	Signal Name	Function		
1	SDA	I ² C Data (Bi-Directional) – Devices Function as Auxiliary Devices		
2	GND	Ground: Power and Signal Ground		
3	GND	Ground: Power and Signal Ground		
4	Scan Sense	Level changes from High to low or low to high when the laser changes direction at the start of the scan line		
5	Data	High = Bar		
		Low = Space		
6	Scan Enable	High = Engine OFF		
		Low = Engine ON		
7	Laser Enable	High = Laser OFF		
		Low = Laser ON		
8	NC	No Connection		
9	+3.3V or 5.0V	Power: Supply Voltage Output, +3.3V \pm 0.3V or +5.0V \pm 5%		
10	SCL	I ² C Data (Bi-Directional) – Devices Function as Auxiliary Devices		

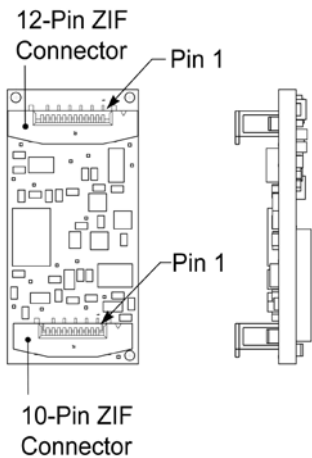

Figure 21.

Flex Cable Specifications and Installation Guidelines

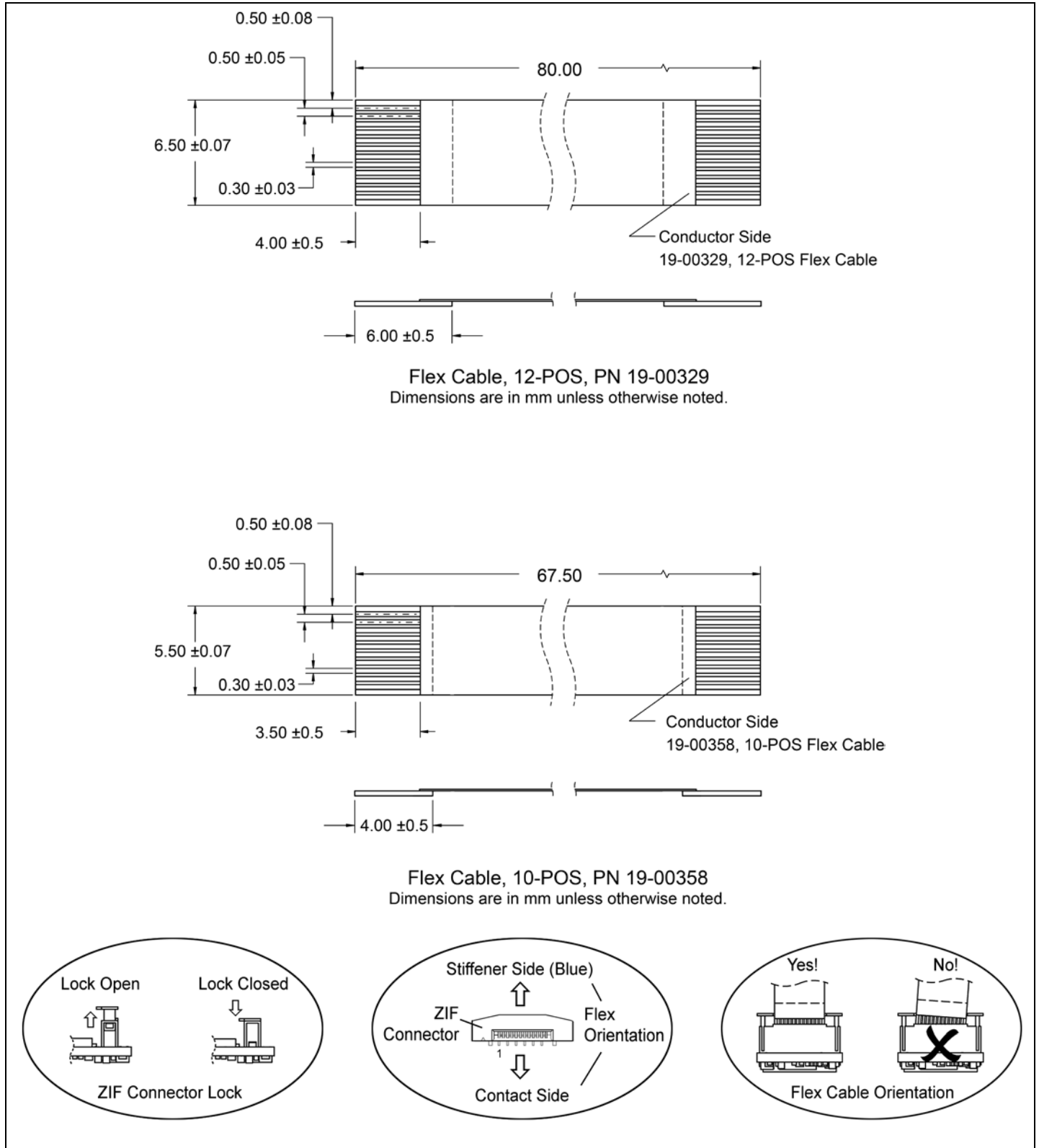

Figure 22. Flex Cable Specifications and Installation Guidelines

Specifications are subject to change without notice.

Bar Code Element Time Calculation

Realization of the full depth of field for all bar codes given in the specification is based on the ability of the decoding hardware to resolve a varying range of minimum element times. The minimum element time calculation for a given bar code size at a given distance is shown in Equation 1 (*below*).

$$\text{Minimum Element Time} = (\text{Element Size} / \text{Spot Speed})$$

Equation 1.

Example:

Bar code Size = 5.2 mil

Spot Speed @ 95 mm from face = 650 inches/second

Minimum Element Time = (0.0052 inches/ (650 inches/second)) = 8.0 μ sec

Regulatory Compliance

Note: THIS DEVICE DOES NOT COMPLY WITH 21 CFR 1040. USE ONLY AS A COMPONENT.

The IS4800 Series Laser Scan engines are designed to meet the requirements of IEC Class 2 in accordance with IEC 60825-1:2007. IEC Class 2 is defined as follows:

Emission Duration: Greater than 0.25 seconds

Accessible Emission Limit: Less than 0.001 W (1.0 milliwatt) average radiant power

The IS4800 laser scan engine series is registered with the Center for Devices and Radiological Health as a laser "component". The addition of shutdown controls, labeling and informational requirements are necessary to achieve compliance with the performance standard published in the Code of Federal Regulations (CFR), Title 21 Parts 1040.10 and 1040.11. **It is the responsibility of the manufacturer who incorporates the scan engine into their product to provide the additional performance, labeling, and informational requirements necessary to comply with all federal laser safety regulations.**

The specifications required for agency approval are not obtainable until the IS4800 engine is used in its final configuration. Honeywell is unable to fulfill these requirements because the scan engine will operate differently depending upon where it is used as a component. The following information concerning the scan engine appears on the shipping label:

THIS DEVICE DOES NOT COMPLY WITH 21 CFR 1040.
USE ONLY AS A COMPONENT.



This device has been tested in accordance with and complies with IEC60825-1 ed2.0.

LASER LIGHT, DO NOT STARE INTO BEAM, CLASS 2 LASER PRODUCT, 1.0mW MAX OUTPUT: 650nm.

The scan engine contains an embedded laser diode rated 640-660nm, 10mW maximum and a minimum beam divergence of 6 degrees.

Caution: Use of controls, adjustments, or performance of procedures other than those specified herein may result in hazardous radiation exposure.

A statement of the compatibility requirements for a laser energy source to ensure safety.

Manufacturers incorporating unmodified IS4800 engines into their product may reference the following accession number on items in their Laser Product Report that request information concerning features inherent in the IS4800 engine design.

Accession Number: 0620138-00

It is the responsibility of the manufacturer who incorporates the scan engine into their product to obtain country specific regulatory compliance prior to the sale of the product. Refer to one of the following sections for further explanation.

United States: Refer to page 35 for more information.

Canada: Refer to page 36 for more information.

Europe: Refer to page 36 for more information.

United States

Laser Safety

To assist with the FDA filing requirements (refer to Regulatory Requirements), Honeywell has registered the scan engine with the FDA as a component. Customers can contact CDRH at the following address:

U.S. Food and Drug Administration
Center for Devices and Radiological Health
Document Mail Center – WO66-G609
10903 New Hampshire Avenue
Silver Spring, MD 20993-0002
Tel: 800-638-2041

www.fda.gov

Requirements for laser products are described in CFR (Code of Federal Regulation) Title 21, part 1040.10 & 1040.11 from the Government Printing Office. Copies can be ordered by calling 202-512-1800, ordering on line from www.access.gpo.gov or writing to:

Superintendent of Documents
PO Box 371954
Pittsburgh, PA 15250-7954

Note: State and local governments may regulate the use products containing lasers. The manufacturer should consult the applicable government regulations for more information.

Copies of Product Reporting Guides, other guides, and related documents are available as PDF documents from the CDRH website at: [http://www.fda.gov/](http://www.fda.gov). Additional resources include the Division of Small Manufacturers, International and Consumer Assistance (DSMICA) in Rockville, Maryland at 1-800-638-2041.

EMC

Certain combinations of scan engines and associated electronics may require testing to insure compliance with the following Federal Communications Commission regulation: 47 CFR Part 15

Note: When using the scan engine with RF equipment, modems, etc. may require examination(s) to the standard(s) for the specific equipment combination. It is the manufacturers' responsibility to comply with the applicable federal regulation(s).

The IS4800 series laser scan engine is designed to meet EN55022 Radiated Class B emission limits. The engine was installed in a representative system and tested for compliance.

Canada

Laser Safety

The Radiation Protection Bureau currently accepts products meeting the FDA standards in Canada. For more information contact:

Radiation Protection Bureau
775 Brookfield Road
Ottawa, Ontario K1A 1C1

EMC

Products meeting FCC 47 CFR Part 15 will meet Industry Canada interference-causing equipment standard for digital apparatus, ICES-003. Additional testing is not required.

A written notice indicating compliance must accompany the apparatus to the end user. The notice shall be in the form of a label that is affixed to the apparatus. The notice may be in the form of a statement included in the user's manual if, because of insufficient space or other restrictions, it is not feasible to affix a label to the apparatus.

Europe

The CE Mark is required on products, which incorporate the IS4813, and the IS4815 scan engines if the products are to be imported into European Economic Area (EEA) countries. Use of the CE Mark requires compliance with directives and standards dependent upon the type of product. Information may be found at <http://ec.europa.eu/>.

Laser Safety

IEC 60825-1:2007,
EN 60825-1:2007
"Safety of Laser products"

Compliance with either of the standards listed above is required for the product to bear the CE mark.

Note: Non EEA countries may impose additional testing/certification requirements.

EMC

Certain combinations of IS4800 scan engines and associated electronics may require certification of compliance with the European EMC Directive. EMC compliance of finished products in Europe can be accomplished by the following method:

- The manufacturer may certify to the EC's Electromagnetic Compatibility Directive 2004/108/EC. Compliance is required for the product to bear the CE Mark.

Note: Non EEA countries may impose additional testing/certification requirements.

The IS4800 series laser scan engine is designed to meet EN55022 Radiated Class B emission limits. The engine was installed in a representative system and tested for compliance.

Electrical Safety

The scan engines are built to conform to the European Low Voltage Directive 2006/95/EC.

Caution

Use of controls or adjustments or performance of procedures other than those specified herein may result in hazardous laser light exposure. Under no circumstances should the customer attempt to service the laser scanner. Never attempt to look at the laser beam, even if the scanner appears to be nonfunctional. Never open the scanner in an attempt to look into the device. Doing so could result in hazardous laser light exposure. The use of optical instruments with the laser equipment will increase eye hazard.

Atención

La modificación de los procedimientos, o la utilización de controles o ajustes distintos de los especificados aquí, pueden provocar una luz de láser peligrosa. Bajo ninguna circunstancia el usuario deberá realizar el mantenimiento del láser del escáner. Ni intentar mirar al haz del láser incluso cuando este no esté operativo. Tampoco deberá abrir el escáner para examinar el aparato. El hacerlo puede conllevar una exposición peligrosa a la luz de láser. El uso de instrumentos ópticos con el equipo láser puede incrementar el riesgo para la vista.

Attention

L'emploi de commandes, réglages ou procédés autres que ceux décrits ici peut entraîner de graves irradiations. Le client ne doit en aucun cas essayer d'entretenir lui-même le scanner ou le laser. Ne regardez jamais directement le rayon laser, même si vous croyez que le scanner est inactif. N'ouvrez jamais le scanner pour regarder dans l'appareil. Ce faisant, vous vous exposez à une rayonnement laser qui est dangereux. L'emploi d'appareils optiques avec cet équipement laser augmente le risque d'endommagement de la vision.

Achtung

Die Verwendung anderer als der hier beschriebenen Steuerungen, Einstellungen oder Verfahren kann eine gefährliche Laserstrahlung hervorrufen. Der Kunde sollte unter keinen Umständen versuchen, den Laser-Scanner selbst zu warten. Sehen Sie niemals in den Laserstrahl, selbst wenn Sie glauben, daß der Scanner nicht aktiv ist. Öffnen Sie niemals den Scanner, um in das Gerät hineinzusehen. Wenn Sie dies tun, können Sie sich einer gefährlichen Laserstrahlung aussetzen. Der Einsatz optischer Geräte mit dieser Laserausrüstung erhöht das Risiko einer Sehschädigung.

Attenzione

L'utilizzo di sistemi di controllo, di regolazioni o di procedimenti diversi da quelli descritti nel presente Manuale può provocare delle esposizioni a raggi laser rischiose. Il cliente non deve assolutamente tentare di riparare egli stesso lo scanner laser. Non guardate mai il raggio laser, anche se credete che lo scanner non sia attivo. Non aprite mai lo scanner per guardare dentro l'apparecchio. Facendolo potete esporVi ad una esposizione laser rischiosa. L'uso di apparecchi ottici, equipaggiati con raggi laser, aumenta il rischio di danni alla vista.

Limited Warranty

Honeywell International Inc. ("HII") warrants its products and optional accessories to be free from defects in materials and workmanship and to conform to HII's published specifications applicable to the products purchased at the time of shipment. This warranty does not cover any HII product which is (i) improperly installed or used; (ii) damaged by accident or negligence, including failure to follow the proper maintenance, service, and cleaning schedule; or (iii) damaged as a result of (A) modification or alteration by the purchaser or other party, (B) excessive voltage or current supplied to or drawn from the interface connections, (C) static electricity or electro-static discharge, (D) operation under conditions beyond the specified operating parameters, or (E) repair or service of the product by anyone other than HII or its authorized representatives.

This warranty shall extend from the time of shipment for the duration published by HII for the product at the time of purchase ("Warranty Period"). Any defective product must be returned (at purchaser's expense) during the Warranty Period to HII factory or authorized service center for inspection. No product will be accepted by HII without a Return Materials Authorization, which may be obtained by contacting HII. In the event that the product is returned to HII or its authorized service center within the Warranty Period and HII determines to its satisfaction that the product is defective due to defects in materials or workmanship, HII, at its sole option, will either repair or replace the product without charge, except for return shipping to HII.

EXCEPT AS MAY BE OTHERWISE PROVIDED BY APPLICABLE LAW, THE FOREGOING WARRANTY IS IN LIEU OF ALL OTHER COVENANTS OR WARRANTIES, EITHER EXPRESSED OR IMPLIED, ORAL OR WRITTEN, INCLUDING, WITHOUT LIMITATION, ANY IMPLIED WARRANTIES OF MERCHANTABILITY OR FITNESS FOR A PARTICULAR PURPOSE, OR NON-INFRINGEMENT.

HII'S RESPONSIBILITY AND PURCHASER'S EXCLUSIVE REMEDY UNDER THIS WARRANTY IS LIMITED TO THE REPAIR OR REPLACEMENT OF THE DEFECTIVE PRODUCT WITH NEW OR REFURBISHED PARTS. IN NO EVENT SHALL HII BE LIABLE FOR INDIRECT, INCIDENTAL, OR CONSEQUENTIAL DAMAGES, AND, IN NO EVENT, SHALL ANY LIABILITY OF HII ARISING IN CONNECTION WITH ANY PRODUCT SOLD HEREUNDER (WHETHER SUCH LIABILITY ARISES FROM A CLAIM BASED ON CONTRACT, WARRANTY, TORT, OR OTHERWISE) EXCEED THE ACTUAL AMOUNT PAID TO HII FOR THE PRODUCT. THESE LIMITATIONS ON LIABILITY SHALL REMAIN IN FULL FORCE AND EFFECT EVEN WHEN HII MAY HAVE BEEN ADVISED OF THE POSSIBILITY OF SUCH INJURIES, LOSSES, OR DAMAGES. SOME STATES, PROVINCES, OR COUNTRIES DO NOT ALLOW THE EXCLUSION OR LIMITATIONS OF INCIDENTAL OR CONSEQUENTIAL DAMAGES, SO THE ABOVE LIMITATION OR EXCLUSION MAY NOT APPLY TO YOU.

All provisions of this Limited Warranty are separate and severable, which means that if any provision is held invalid and unenforceable, such determination shall not affect the validity of enforceability of the other provisions hereof. Use of any peripherals not provided by the manufacturer may result in damage not covered by this warranty. This includes but is not limited to: cables, power supplies, cradles, and docking stations. HII extends these warranties only to the first end-users of the products. These warranties are non-transferable.

The duration of the limited warranty for the IS4800 series is two (2) year(s).

Index

A	
Accessories	3
Activate	See Modes
Aperture	
clearance	13
ASCII	22, 23
Assignments	
pin	28
B	
Beam	
aperture	9, 10
clearance	11, 13
exit angle	9, 10, 14
specifications	9, 10
Bracket	3, 5, 7
C	
CMOS	28
Compliance	38
Connector	
10-Pin ZIF	28
pin assignments	28
Contaminants	12
Current	25
operating	25
standby	25
Customer Service	38
D	
D/E	20
DC2	20
Decode	2, 3, 4–5, 8, 17
Depth of Field	17
Design	
specifications	24, 25
Dimensions	24
E	
Electrical	
Current Draw	26
DC voltages	26
Max Ratings	26
safety	25
Electrostatic Discharge	11
EMC	34–37
EMI	12
Enclosure	11
F	
Field of View	17
Flex Cable	3, 4–5, 12
G	
Ground	11, 28
I	
I/O	20
Interface	
TTL, RS232	3, 8, 24
USB	3, 8, 12, 24
L	
Labels	3
Laser	
aperture	4–5
beam	11
class	25
enable	28
mode	20
power	24
safety	4–5, 34–37
VLD	11
LED	20
Light Source	24
M	
Magnetic Sensitivity	11, 12
Mode	
serial	22
Modes	20–21
N	
Non-Decode	2, 3, 4, 6, 17
P	
PCB	8
Pin	4, 28
Power	11, 28
R	
Regulatory Compliance	34–37
Repair	38
RMA	38
RTS	20
S	
Safety	34–37
Scan	
enable	28
Scan Field	
depth	24
width	24

Scan Sense	19, 28
Scan Speed	24
Screws	6–8
Serial Configuration	22
Service	38
Signals	26

T

Tape	8
Temperature	12, 25
Thermal Temperature	1, 12
Timeout	20
Timing	19
Torque	6–8
Trigger	20

V

Voltage	11, 12, 25
---------------	------------

W

Warranty	38
Weight	24
Window	
angle	14–16
coatings	13, 14
materials	13
specifications	13–16
transmission	13

Z

ZIF	4–5, 24, 28
-----------	-------------

Customer Support

Technical Assistance

If you need assistance installing or troubleshooting your device, please contact us by using one of the methods below:

Knowledge Base: www.hsmknowledgebase.com

Our Knowledge Base provides thousands of immediate solutions. If the Knowledge Base cannot help, our Technical Support Portal (see below) provides an easy way to report your problem or ask your question.

Technical Support Portal: www.hsmsupportportal.com

The Technical Support Portal not only allows you to report your problem, but it also provides immediate solutions to your technical issues by searching our Knowledge Base. With the Portal, you can submit and track your questions online and send and receive attachments.

Web form: www.hsmcontactsupport.com

You can contact our technical support team directly by filling out our online support form. Enter your contact details and the description of the question/problem.

Telephone: www.honeywellaidc.com/locations

For our latest contact information, please check our website at the link above.

Product Service and Repair

Honeywell International Inc. provides service for all of its products through service centers throughout the world. To obtain warranty or non-warranty service, please visit www.honeywellaidc.com and select Support > Contact Service and Repair to see your region's instructions on how to obtain a Return Material Authorization number (RMA #). You should do this prior to returning the product."

Honeywell Scanning & Mobility

9680 Old Bailes Road
Fort Mill, SC 29707
www.honeywellaidc.com

Free Manuals Download Website

<http://myh66.com>

<http://usermanuals.us>

<http://www.somanuals.com>

<http://www.4manuals.cc>

<http://www.manual-lib.com>

<http://www.404manual.com>

<http://www.luxmanual.com>

<http://aubethermostatmanual.com>

Golf course search by state

<http://golfingnear.com>

Email search by domain

<http://emailbydomain.com>

Auto manuals search

<http://auto.somanuals.com>

TV manuals search

<http://tv.somanuals.com>