



**Addressable Fire Alarm Control Panel
MS-9600LS/MS-9600LSE
MS-9600UDLS/MS-9600UDLSE
MS-9600LSC
Manual**

Document 52646 2/12/2010	Rev: B2
P/N 52646:B2	ECN 10-098

Fire Alarm System Limitations

While a fire alarm system may lower insurance rates, it is not a substitute for fire insurance!

An automatic fire alarm system—typically made up of smoke detectors, heat detectors, manual pull stations, audible warning devices, and a fire alarm control panel with remote notification capability—can provide early warning of a developing fire. Such a system, however, does not assure protection against property damage or loss of life resulting from a fire.

The Manufacturer recommends that smoke and/or heat detectors be located throughout a protected premise following the recommendations of the National Fire Protection Association Standard 72 (NFPA 72), manufacturer's recommendations, State and local codes, and the recommendations contained in the Guides for Proper Use of System Smoke Detectors, which are made available at no charge to all installing dealers. These documents can be found at <http://www.systemsensor.com/html/applicat.html>. A study by the Federal Emergency Management Agency (an agency of the United States government) indicated that smoke detectors may not go off in as many as 35% of all fires. While fire alarm systems are designed to provide early warning against fire, they do not guarantee warning or protection against fire. A fire alarm system may not provide timely or adequate warning, or simply may not function, for a variety of reasons:

Smoke detectors may not sense fire where smoke cannot reach the detectors such as in chimneys, in or behind walls, on roofs, or on the other side of closed doors. Smoke detectors also may not sense a fire on another level or floor of a building. A second-floor detector, for example, may not sense a first-floor or basement fire.

Particles of combustion or "smoke" from a developing fire may not reach the sensing chambers of smoke detectors because:

- Barriers such as closed or partially closed doors, walls, or chimneys may inhibit particle or smoke flow.
- Smoke particles may become "cold," stratify, and not reach the ceiling or upper walls where detectors are located.
- Smoke particles may be blown away from detectors by air outlets.
- Smoke particles may be drawn into air returns before reaching the detector.

The amount of "smoke" present may be insufficient to alarm smoke detectors. Smoke detectors are designed to alarm at various levels of smoke density. If such density levels are not created by a developing fire at the location of detectors, the detectors will not go into alarm.

Smoke detectors, even when working properly, have sensing limitations. Detectors that have photoelectronic sensing chambers tend to detect smoldering fires better than flaming fires, which have little visible smoke. Detectors that have ionizing-type sensing chambers tend to detect fast-flaming fires better than smoldering fires. Because fires develop in different ways and are often unpredictable in their growth, neither type of detector is necessarily best and a given type of detector may not provide adequate warning of a fire.

Smoke detectors cannot be expected to provide adequate warning of fires caused by arson, children playing with matches (especially in bedrooms), smoking in bed, and violent explosions (caused by escaping gas, improper storage of flammable materials, etc.).

Heat detectors do not sense particles of combustion and alarm only when heat on their sensors increases at a predetermined rate or reaches a predetermined level. Rate-of-rise heat detectors may be subject to reduced sensitivity over time. For this reason, the rate-of-rise feature of each detector should be tested at least once per year by a qualified fire protection specialist. Heat detectors are designed to protect property, not life.

IMPORTANT! Smoke detectors must be installed in the same room as the control panel and in rooms used by the system for the connection of alarm transmission wiring, communications, signaling, and/or power. If detectors are not so located, a developing fire may damage the alarm system, crippling its ability to report a fire.

Audible warning devices such as bells may not alert people if these devices are located on the other side of closed or partly open doors or are located on another floor of a building. Any warning device may fail to alert people with a disability or those who have recently consumed drugs, alcohol or medication. Please note that:

- Strobes can, under certain circumstances, cause seizures in people with conditions such as epilepsy.
- Studies have shown that certain people, even when they hear a fire alarm signal, do not respond or comprehend the meaning of the signal. It is the property owner's responsibility to conduct fire drills and other training exercise to make people aware of fire alarm signals and instruct them on the proper reaction to alarm signals.
- In rare instances, the sounding of a warning device can cause temporary or permanent hearing loss.

A fire alarm system will not operate without any electrical power. If AC power fails, the system will operate from standby batteries only for a specified time and only if the batteries have been properly maintained and replaced regularly.

Equipment used in the system may not be technically compatible with the control panel. It is essential to use only equipment listed for service with your control panel.

Telephone lines needed to transmit alarm signals from a premise to a central monitoring station may be out of service or temporarily disabled. For added protection against telephone line failure, backup radio transmission systems are recommended.

The most common cause of fire alarm malfunction is inadequate maintenance. To keep the entire fire alarm system in excellent working order, ongoing maintenance is required per the manufacturer's recommendations, and UL and NFPA standards. At a minimum, the requirements of NFPA 72 shall be followed. Environments with large amounts of dust, dirt or high air velocity require more frequent maintenance. A maintenance agreement should be arranged through the local manufacturer's representative. Maintenance should be scheduled monthly or as required by National and/or local fire codes and should be performed by authorized professional fire alarm installers only. Adequate written records of all inspections should be kept.

Limit-C1-2-2007

Installation Precautions

Adherence to the following will aid in problem-free installation with long-term reliability:

WARNING - Several different sources of power can be connected to the fire alarm control panel. Disconnect all sources of power before servicing. Control unit and associated equipment may be damaged by removing and/or inserting cards, modules, or interconnecting cables while the unit is energized. Do not attempt to install, service, or operate this unit until manuals are read and understood.

CAUTION - System Re-acceptance Test after Software Changes: To ensure proper system operation, this product must be tested in accordance with NFPA 72 after any programming operation or change in site-specific software. Re-acceptance testing is required after any change, addition or deletion of system components, or after any modification, repair or adjustment to system hardware or wiring. All components, circuits, system operations, or software functions known to be affected by a change must be 100% tested. In addition, to ensure that other operations are not inadvertently affected, at least 10% of initiating devices that are not directly affected by the change, up to a maximum of 50 devices, must also be tested and proper system operation verified.

This system meets NFPA requirements for operation at 0-49° C/32-120° F and at a relative humidity 93% ± 2% RH (non-condensing) at 32°C ± 2°C (90°F ± 3°F). However, the useful life of the system's standby batteries and the electronic components may be adversely affected by extreme temperature ranges and humidity. Therefore, it is recommended that this system and its peripherals be installed in an environment with a normal room temperature of 15-27° C/60-80° F.

Verify that wire sizes are adequate for all initiating and indicating device loops. Most devices cannot tolerate more than a 10% I.R. drop from the specified device voltage.

Like all solid state electronic devices, this system may operate erratically or can be damaged when subjected to lightning induced transients. Although no system is completely immune from lightning transients and interference, proper grounding will reduce susceptibility. Overhead or outside aerial wiring is not recommended, due to an increased susceptibility to nearby lightning strikes. Consult with the Technical Services Department if any problems are anticipated or encountered.

Disconnect AC power and batteries prior to removing or inserting circuit boards. Failure to do so can damage circuits.

Remove all electronic assemblies prior to any drilling, filing, reaming, or punching of the enclosure. When possible, make all cable entries from the sides or rear. Before making modifications, verify that they will not interfere with battery, transformer, or printed circuit board location.

Do not tighten screw terminals more than 9 in-lbs. Overtightening may damage threads, resulting in reduced terminal contact pressure and difficulty with screw terminal removal.

This system contains static-sensitive components. Always ground yourself with a proper wrist strap before handling any circuits so that static charges are removed from the body. Use static suppressive packaging to protect electronic assemblies removed from the unit.

Follow the instructions in the installation, operating, and programming manuals. These instructions must be followed to avoid damage to the control panel and associated equipment. FACP operation and reliability depend upon proper installation.

Precau-D1-9-2005

FCC Warning

WARNING: This equipment generates, uses, and can radiate radio frequency energy and if not installed and used in accordance with the instruction manual may cause interference to radio communications. It has been tested and found to comply with the limits for class A computing devices pursuant to Subpart B of Part 15 of FCC Rules, which is designed to provide reasonable protection against such interference when devices are operated in a commercial environment. Operation of this equipment in a residential area is likely to cause interference, in which case the user will be required to correct the interference at his or her own expense.

Canadian Requirements

This digital apparatus does not exceed the Class A limits for radiation noise emissions from digital apparatus set out in the Radio Interference Regulations of the Canadian Department of Communications.

Le present appareil numerique n'emet pas de bruits radioelectriques depassant les limites applicables aux appareils numeriques de la classe A prescrites dans le Reglement sur le brouillage radioelectrique edicte par le ministere des Communications du Canada.

LiteSpeed™ is a trademark; and FireLite® Alarms is a registered trademark of Honeywell International Inc. Microsoft® and Windows® are registered trademarks of the Microsoft Corporation.

©Tuesday, August 14, 2012 9:31 am by Honeywell International Inc. All rights reserved. Unauthorized use of this document is strictly prohibited.

Software Downloads

In order to supply the latest features and functionality in fire alarm and life safety technology to our customers, we make frequent upgrades to the embedded software in our products. To ensure that you are installing and programming the latest features, we strongly recommend that you download the most current version of software for each product prior to commissioning any system. Contact Technical Support with any questions about software and the appropriate version for a specific application.

Documentation Feedback

Your feedback helps us keep our documentation up-to-date and accurate. If you have any comments or suggestions about our online Help or printed manuals, you can email us.

Please include the following information:

- Product name and version number (if applicable)
- Printed manual or online Help
- Topic Title (for online Help)
- Page number (for printed manual)
- Brief description of content you think should be improved or corrected
- Your suggestion for how to correct/improve documentation

Send email messages to:

FireSystems.TechPubs@honeywell.com

Please note this email address is for documentation feedback only. If you have any technical issues, please contact Technical Services.

Table of Contents

Section 1: Product Description	13
1.1: Inventory	13
1.2: Features and Options	13
1.3: Specifications.....	15
1.3.1: Current Availability.....	17
1.4: Controls and Indicators.....	17
1.5: Circuits.....	18
1.6: Components	19
1.6.1: Intelligent Addressable Detectors: Newer Series	20
1.6.2: Intelligent Addressable Modules: Newer Series	20
1.6.3: 300 Series Intelligent Addressable Devices	20
1.6.4: Addressable Device Accessories.....	20
1.7: Optional Modules	21
1.8: Accessories	21
1.8.1: PS-Tools Programming Utility.....	21
1.8.2: Dress Panel: DP-9692.....	22
1.8.3: TR-CE Trim Ring.....	22
1.8.4: Battery Box.....	22
1.8.5: Battery Charger.....	22
CHG-75 Battery Charger.....	22
CHG-120 Battery Charger.....	22
1.8.6: New ANN-BUS Annunciators/Devices	23
ANN-BUS Wiring	23
ANN-BUS Device Addressing.....	26
ANN-80 Remote Fire Annunciator	27
ANN-S/PG Serial/Parallel Interface Installation.....	30
ANN-I/O LED Driver Module*	32
ANN-LED Annunciator Module*	34
ANN-RLY Annunciator Module.....	36
ANN-BUS Audio Panel Control	38
1.8.7: Legacy ACS Annunciators	40
1.9: Getting Started	40
Section 2: Installation.....	42
2.1: Mounting.....	42
2.2: Power	46
2.2.1: AC Power and Earth Ground Connection	46
2.2.2: Battery Power	46
2.2.3: Special Application DC Power Output Connection	47
2.3: Relays	47
2.4: Notification Appliance Circuits	47
2.4.1: Configuring NACs.....	48
2.4.2: Style Y (Class B) NAC Wiring	49
2.4.3: Style Z (Class A) NAC Wiring.....	49
2.5: Power-limited Wiring Requirements	50
2.6: Optional Modules and Devices.....	51
2.6.1: DACT-UD2 Installation	52
2.6.2: 4XTMF Transmitter Module Installation.....	55
2.6.3: Auxiliary Trouble Input (J16 & J17).....	57
2.6.4: SLC-2LS Expander Module	57
2.6.5: Printer/PC	58
2.6.6: Annunciators.....	59
Legacy ACM-8RF Relay Control Module.....	59
Legacy ACM Series Annunciators.....	60

Section 3: Programming	61
3.1: Programming Data Entry	61
3.2: User Programming	62
3.3: Initial Power-up	63
3.4: Programming Screens Description	63
3.5: Programming and Passwords	63
3.6: Master Programming Level	65
3.6.1: Autoprogram	66
3.6.2: Point Program	67
Detector Programming	67
Module Programming	78
3.6.3: Zone Setup	95
Enable	95
Disable	96
Zone 97, 98 and 99	96
Zones Installed	97
Zones Enabled	97
Zones Disabled	97
Zone Type	98
Zones Available	99
3.6.4: Loop Setup	99
Loop Selection	99
Loop Protocol	100
3.6.5: System Setup	100
Trouble Reminder	101
Banner	101
Time-Date	103
Timers	105
NAC (Notification Appliance Circuit)	107
Relays	112
Canadian Option	113
Waterflow Silenceable	114
3.6.6: Verify Loops	114
3.6.7: History	115
View Events	115
Erase History	115
3.6.8: Walktest	116
3.6.9: Option Modules	117
Annunciators/UDACT	118
On Board DACT	134
Printer/PC	134
3.6.10: Password Change	135
3.6.11: Clear Program	136
3.6.12: Program Check	137
3.7: Maintenance Programming Level	138
3.7.1: Disable Point	139
3.7.2: History	140
3.7.3: Program Check	141
3.7.4: Walktest	142
3.7.5: System	143
3.7.6: Zone Setup	144
Zones Installed	146
Zones Enabled	146
Zones Disabled	147
Zone Type	147
Zones Available	148
Zone Message	149

Section 4: Operating Instructions	150
4.1: Panel Control Buttons.....	150
4.1.1: Acknowledge/Step.....	150
4.1.2: Alarm Silence.....	150
4.1.3: Drill/Hold 2 Sec.....	150
4.1.4: Reset.....	150
4.2: LED Indicators.....	150
4.3: Normal Operation.....	151
4.4: Trouble Operation.....	152
4.5: Alarm Operation.....	153
4.6: Supervisory Operation.....	154
4.7: Process Monitor Operation.....	155
4.8: Hazard Condition Operation.....	155
4.9: Medical Alert Condition Operation.....	156
4.10: Programmed Zone Operation.....	156
4.11: Disable/Enable Operation.....	156
4.12: Waterflow Circuits Operation.....	156
4.13: Detector Functions.....	156
4.14: Time Functions: Real-Time Clock.....	157
4.15: NAC Operation.....	157
4.16: Synchronized NAC Operation.....	157
4.17: Coded Operation.....	157
4.18: Presignal.....	158
4.19: Positive Alarm Sequence.....	158
4.20: Special System Timers.....	159
4.20.1: Silence Inhibit Timer.....	159
4.20.2: Autosilence Timer.....	159
4.20.3: Trouble Reminder.....	159
4.20.4: Waterflow Retard Timer.....	159
4.20.5: Alarm Verification.....	159
4.21: Walktest.....	160
4.22: Read Status.....	160
4.22.1: System Point.....	162
4.22.2: Zones.....	163
4.22.3: Power.....	164
4.22.4: Trouble Reminder.....	165
4.22.5: Timers.....	165
4.22.6: NAC.....	166
4.22.7: Relays.....	166
4.22.8: Program Check.....	167
4.22.9: History.....	167
4.22.10: Annunciators.....	167
4.22.11: Phone Line.....	169
4.22.12: Central Station.....	169
4.22.13: Service Terminal.....	170
4.22.14: Printer/PC.....	170
4.22.15: Print.....	171
4.22.16: Time-Date.....	173
Section 5: Power Supply Calculations.....	174
5.1: Overview.....	174
5.2: Calculating the AC Branch Circuit.....	174
5.3: Calculating the System Current Draw.....	174
5.3.1: Overview.....	174
5.3.2: How to Use Table 5.3 on page 176 to Calculate System Current Draw.....	175
5.4: Calculating the Battery Size.....	177
5.4.1: NFPA Battery Requirements.....	177

5.4.2: Selecting and Locating Batteries	177
Appendix A: Software Zones	178
A.1: Correlations	178
Appendix B: Default Programming	186
Appendix C: NFPA Standard-Specific Requirements	187
C.1: Central Station/Remote Station Transmitter: Connection to FACP Dry Contacts	193
C.2: MBT-1 Municipal Box Trip - Silenceable	194
Appendix D: FACP with Keltron	195
Appendix E: Wire Requirements	196
E.1: NAC Wiring	197
Appendix F: HVAC Control	198
F.1: Control Module Operation	198
F.1.1: HVAC SHUTDN	198
F.2: Monitor Module Operation	198
F.2.1: HVAC RESTART	198
F.2.2: HVAC OVERRIDE	199
Appendix G: Canadian Application	200
Index	201

It is imperative that the installer understand the requirements of the Authority Having Jurisdiction (AHJ) and be familiar with the standards set forth by the following regulatory agencies:

- Underwriters Laboratories Standards
- NFPA 72 National Fire Alarm Code
- CAN/ULC - S527-99 Standard for Control Units for Fire Alarm Systems

Before proceeding, the installer should be familiar with the following documents.



NFPA Standards

NFPA 72 National Fire Alarm Code
NFPA 70 National Electrical Code

Underwriters Laboratories Documents:

UL 38 Manually Actuated Signaling Boxes
UL 217 Smoke Detectors, Single and Multiple Station
UL 228 Door Closers—Holders for Fire Protective Signaling Systems
UL 268 Smoke Detectors for Fire Protective Signaling Systems
UL 268A Smoke Detectors for Duct Applications
UL 346 Waterflow Indicators for Fire Protective Signaling Systems
UL 464 Audible Signaling Appliances
UL 521 Heat Detectors for Fire Protective Signaling Systems
ANSI/UL 864, Control Units and Accessories for Fire Alarm Systems
UL 1481 Power Supplies for Fire Protective Signaling Systems
UL 1610 Central Station Burglar Alarm Units
UL 1638 Visual Signaling Appliances
UL 1971 Signaling Devices for Hearing Impaired
UL 2017 General-Purpose Signaling Devices and System
CAN/ULC - S524-01 Standard for Installation of Fire Alarm Systems
CAN/ULC - S527-99 Standard for Control Units for Fire Alarm Systems
CAN/ULC - S559-04 Equipment for Fire Signal Receiving Centers and Systems
CAN/ULC - S561-03 Installation and Services for Fire Signal Receiving Centers and Systems
Note: MS-9600LSE/MS-9600UDLSE is not ULC listed for Canadian applications
This Class (A) digital apparatus complies with Canadian ICES-003.

Cet appareil numérique de la classe (A) est conforme à la norme NMB-003 du Canada.

FM Approved to ANSI/UL 864

Other:

EIA-232E Serial Interface Standard
EIA-485 Serial Interface Standard
NEC Article 250 Grounding
NEC Article 300 Wiring Methods
NEC Article 760 Fire Protective Signaling Systems
Applicable Local and State Building Codes
Requirements of the Local Authority Having Jurisdiction (LAHJ)

Fire-Lite Documents:

Fire-Lite Device Compatibility	Document #15384
SLC Wiring Manual	Document #51309
ACS Series Annunciators	Document #51480
411UD Communicator/Transmitter	Document #50759
411UDAC Communicator/Transmitter	Document #51073
CHG-120F Battery Charger	Document #50888
CHG-75 Battery Charger	Document #51315
LDM Series Lamp Driver Modules	Document #50055
LCD-80F Remote Fire Annunciator	Document #51338
ACM-8RF Relay Control Module	Document #50362
DACT-UD2 Manual	Document #53037
IDACT Communicator/Transmitter	Document #53109
ANN-80 Installation Document	Document #52749
ANN-(R)LED Installation Document	Document #53032
ANN-I/O Installation Document	Document #151416
ANN-RLY Installation Document	Document #53033
ANN-S/PG Installation Document	Document #151417
ACC-25/50(ZS/T) Manual	Document #51889

This product has been certified to comply with the requirements in the ANSI/UL 864, Standard for Control Units and Accessories for Fire Alarm Systems, 9th Edition. Operation of this product with products not tested for ANSI/UL 864, 9th Edition has not been evaluated. Such operation requires the approval of the local Authority Having Jurisdiction (AHJ).



Basic System Connections

Special Application Power DC Power Outputs (24 VDC)
Power-limited, non-supervised circuits
Supervise with a power supervision relay EOLR-1

Nonresettable Power #2 - 24 VDC filtered, power-limited, (1.5 amps maximum) Supervision required. Suitable for powering annunciators.

Nonresettable Power #1 - 24 VDC filtered, power-limited, (1.5 amps maximum) Supervision required. Suitable for powering annunciators.

Resettable Power - 24 VDC filtered, power-limited, (1.5 amps maximum) to smoke detectors. Supervision required.

Notification Appliance Circuits

Special Application Power
Power-limited, supervised circuits
NAC #1 & #2 Style Z (Class A)
3.0 amps max per circuit
JP8 configured for Class A using NACKEY card

2 Programmable Relays & 1 Fixed Trouble Relay
(non-supervised)
Contact Ratings:
2.0 amps @ 30VDC (resistive)
0.5 amp @ 30 VAC (resistive)
Contacts show in normal condition (AC power with no alarm, trouble, or supervisory activity).

A fail-safe trouble relay switches to the NO position during trouble conditions and under-loss all power.

EIA-232 to printer or personal computer
Power-limited for EDP-listed equipment or personal computer with FACP Upload/Download Utility. 50 foot maximum within same room.

TERM (EIA-485) to LCD-80F
DB9F ACN/ANN-BUS (EIA-485) Red to annunciators' Green (power-limited, supervised), White to annunciators' Black

SLC Loop
(Supervised Power-limited)
Refer to the SLC Wiring Manual for detailed information on wiring addressable devices for Style 4, 6, and 7

Notification Appliance Circuits
Power-limited, supervised circuits
NAC #1, #2, #3, & #4, Style Y (Class B)
3.0 amps max per circuit
JP8 configured for Class B using NACKEY card
(factory default configuration)

NAC #1 NAC #2 NAC #3 NAC #4
ELRs 4.7K, 1/2W

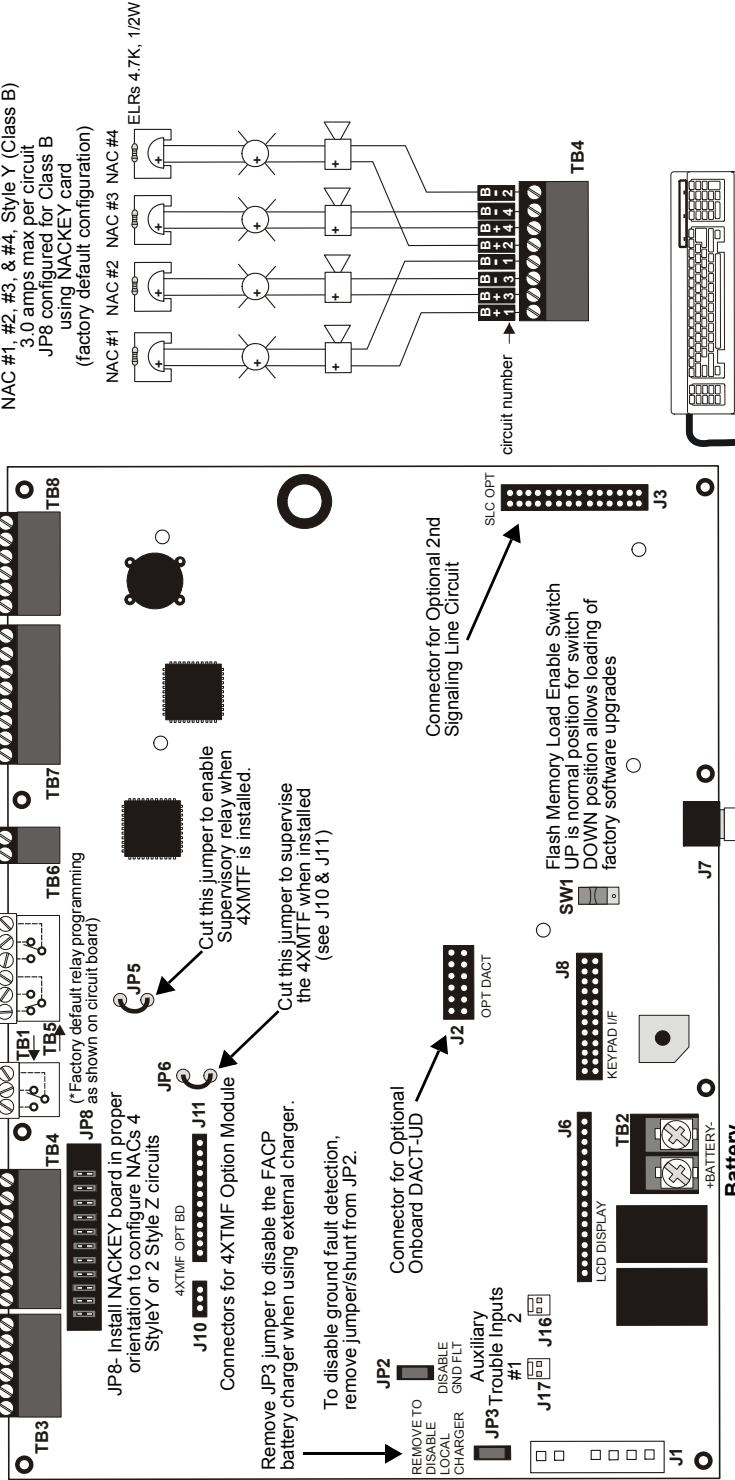

JP8 - Install NACKEY board in proper orientation to configure NACs 4 Style Y or 2 Style Z circuits

JP5 - Cut this jumper to enable Supervisory relay when 4XTMF is installed.

JP6 - Cut this jumper to supervise the 4XTMF when installed (see J10 & J11)

JP2 - Remove JP2 jumper to disable the FACP battery charger when using external charger. To disable ground fault detection, remove jumpers/shunt from JP2.

JP3 - Auxiliary Trouble Inputs #1

JP3 Trouble Inputs #2

JP2 REMOVE TO DISABLE BATTERY CHARGER GND FLT

J2 OPT DACT

J6 KEYPAD I/F

J8 KEYPAD I/F

J7 PS2 Keyboard Interface

J3 SLC OPT Signaling Line Circuit

J17 J16 J1

TB2 LCD DISPLAY

TB1 Alarm* NO NC C NO NC C NO NC C NO NC C NO NC C NO NC C NO NC C NO NC C

TB5 Trouble Supervisory NO NC C NO NC C NO NC C NO NC C NO NC C NO NC C NO NC C NO NC C

TB4 NAC #1 NAC #2

TB7 DB9F ACN/ANN-BUS (EIA-485) Red to annunciators' Green (power-limited, supervised), White to annunciators' Black

TB8

SW1 Flash Memory Load Enable Switch UP is normal position for switch DOWN position allows loading of factory software upgrades

Battery 24 VDC, 26 Amp Hour maximum (supervised, nonpower-limited)

Important: Removing Ground Fault Disable Jumper JP2 voids UL/NFPA Style/Class identification for circuits. Remove jumper JP2 only with AHJ (Authority Having Jurisdiction) approval

Peripheral Devices and Their Documents:

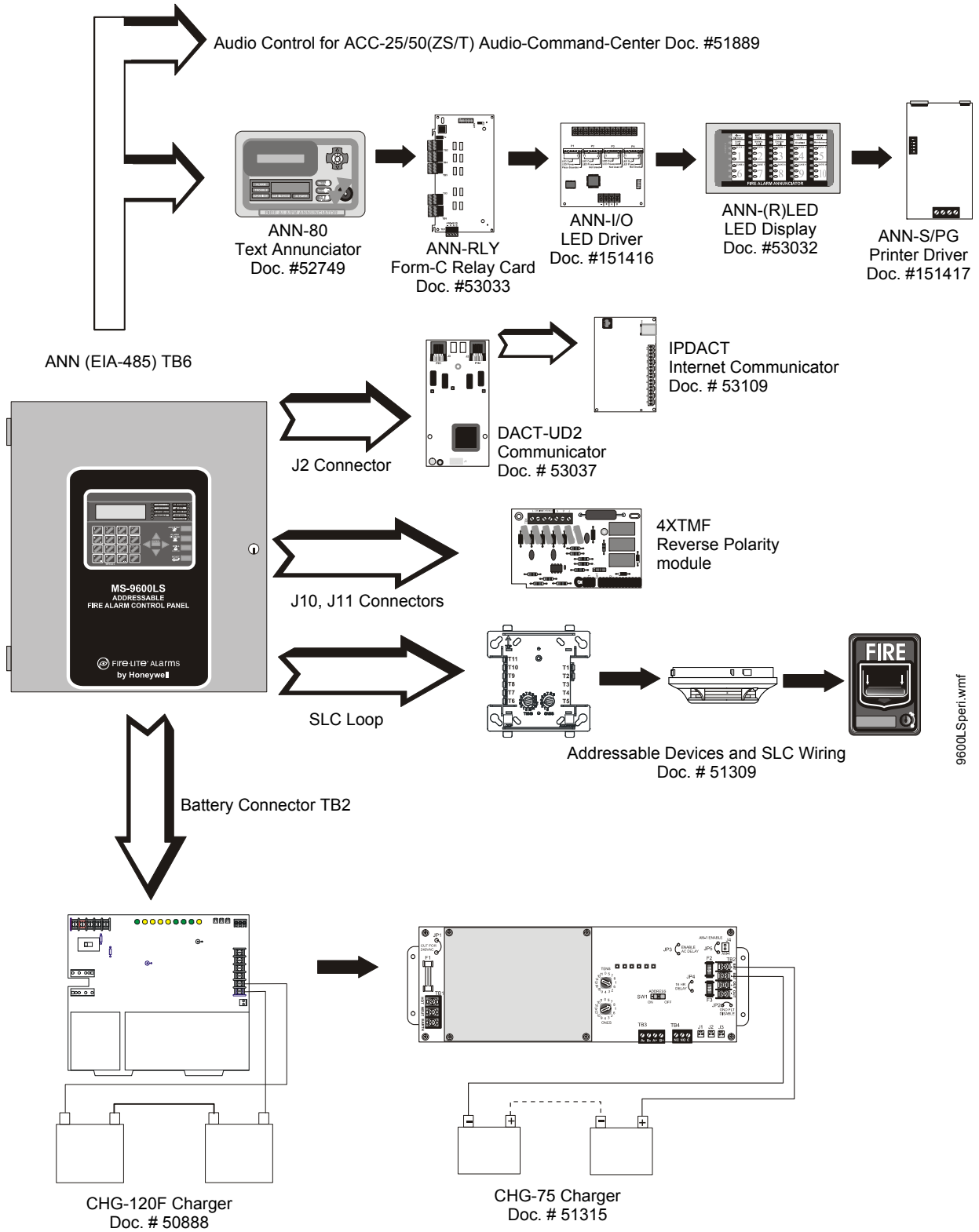

Notes

Section 1: Product Description

The MS-9600LS and MS-9600UDLS are compact, cost effective, intelligent addressable FACPs (Fire Alarm Control Panels) with an extensive list of powerful features. The combination of Fire•Lite's newer series devices and legacy 300 Series devices, along with the MS-9600LS or MS-9600UDLS FACP, offer the latest in fire protection technology. The FLPS-7 power supply is a separate board while all other electronics are contained on a single main circuit board. Both boards are mounted to a chassis and housed in a metal cabinet, providing a complete fire control system for most applications. Optional modules, which plug into the main circuit board, are available for special functions. Available accessories include LED, graphic and LCD annunciators, reverse polarity/city box transmitter, digital alarm communicator/transmitter, SLC expansion module, local and remote upload/download software and remote power expansion.

The MS-9600UDLS includes a factory installed DACT-UD2 Digital Alarm Communicator Transmitter. Refer to "DACT-UD2 Installation" on page 52 and to the DACT-UD2 Manual Document #53037, which is supplied with the FACP, for DACT wiring and programming information. The DACT transmits system status (alarm, troubles, AC loss, etc.) to a Central Station via the public switched telephone network. It also allows remote programming or interrogation of the control panel using the PS-Tools Upload/Download utility via the public switched telephone network. Local programming and interrogation is also possible for the MS-9600UDLS using the PS-Tools and the USB port J4 on the DACT-UD2. The MS-9600LS can be programmed and interrogated locally using the serial port at TB7. Any personal computer with Windows® XP or greater and compatible modem with a speed of 2400 baud or faster and PS-Tools software may serve as a Service Terminal. This allows download of the entire program or upload of the entire program, history file, walktest data, current status and system voltages.

The MS-9600LSC is a ULC approved Canadian version of the FACP which offers the same features as the MS-9600LS, but is supplied standard with a DP-9692 dress panel. Refer to "Canadian Option" on page 113 for a full description.

The MS-9600LSE and MS-9600UDLSE offer the same features as the MS-9600LS and MS-9600UDLS but allow connection to 220/240 VAC input.



NOTE: Unless otherwise specified, the terms FACP, MS-9600LS and MS-9600UDLS are used in this manual to refer to all versions of the FACPs.

1.1 Inventory

When the FACP shipment is received, check to make certain that all parts have been included in the shipment. The FACP shipment should consist of one of each of the following:

- main circuit board with display
- FLPS-7 Power Supply
- chassis (with main circuit board and power supply mounted)
- backbox with door and dress panel
- plastic bag containing screws, cables, key, etc.
- manual

1.2 Features and Options

- New LiteSpeed™ polling protocol for faster SLC response time
- SLC operates up to 10,000 ft. (3,000 m) in LiteSpeed mode with twisted, unshielded wire or 3,000 ft (900 m) with untwisted, unshielded wire
- Single standard addressable SLC loop which meets NFPA Style 4, 6 and 7 requirements

- Optional module for adding a second SLC loop which meets NFPA Style 4, 6 and 7 requirements
- 318 addressable device capacity for each SLC loop (159 detectors and 159 control/monitor modules)
- 99 software zones
- Up to four onboard NACs (Notification Appliance Circuits): four Style Y (Class B) or two Style Z (Class A)
- Additional NAC capability using control modules
- 7.0 amps total power for NACs and 24 VDC auxiliary power outputs in alarm
- Two programmable relay outputs and one fixed trouble relay
- EIA-232 Printer/PC interface (variable baud rate)
- 80-character LCD display (backlit)
- Real-time clock/calendar with daylight savings time control
- History file with 1,000 event capacity
- Advanced fire technology features:
 - Automatic drift compensation
 - Maintenance alert
 - Detector sensitivity test capability (NFPA 72 compliant)
 - Automatic device type-code verification
 - Point trouble identification
- Waterflow selection per module point
- Alarm verification selection per detector point
- Walktest, silent or audible
- PAS (Positive Alarm Sequence) and Pre-signal per point (NFPA 72 compliant)
- New ANN-BUS Annunciators/Modules (ACS annunciators cannot be used when ANN-BUS annunciators/modules are connected)
 - ANN-80 Remote Liquid Crystal Display point annunciator
 - ANN-I/O LED Driver Module
 - ANN-LED Alarm, Trouble, Supervisory Annunciator (minimum of one required for Canadian applications)
 - ANN-RLED Alarm Annunciator
 - ANN-S/PG Serial/Parallel Printer Module
 - ANN-RLY Form-C Relay Module
 - Automated activation of the ACC-25/50(ZS/T) Audio-Command-Center
- Legacy ACS/Term Annunciators: (ANN-BUS annunciator/modules cannot be used when ACS/Term annunciators are connected)
 - ACM Series-LED Zone Annunciators
 - LDM Graphic Annunciator Series
 - LCD-80F Liquid Crystal Display point annunciator (LCD-80FC for Canadian applications)
 - ACM-8RF Relay Module
- Silence inhibit timer option per NAC
- Autosilence timer option per NAC
- Continuous, March Time, Temporal or California code for main circuit board NACs with two-stage capability
- Selectable strobe synchronization per NAC
- Remote Acknowledge, Alarm Silence, Reset and Drill via addressable modules, legacy ACS annunciators or ANN-80 Remote annunciator

- Auto-program (learn mode) reduces installation time. Reports two devices set to the same address
- Password and key-protected nonvolatile memory
- User programmable password
- Fully programmable from local keypad or keyboard or local PC
- Compatible with Fire•Lite's newer series addressable devices (LiteSpeed and CLIP Mode) - Refer to SLC Wiring Manual for listing of all compatible addressable devices
- Compatible with legacy Fire•Lite's 300 Series devices (CLIP Mode only) - Refer to SLC Wiring Manual for listing of all compatible addressable devices
- Optional 4XTMF module (conventional reverse polarity/city box transmitter)
- Optional DACT-UD2 Digital Alarm Communicator Transmitter, reports up to 99 zones or 636 points (all devices) to a UL listed Central Station. The DACT-UD2 is supplied standard with the MS-9600UDLS/E
- Optional PK-CD (contains PS-Tools utility) for local or remote Upload/Download of program and data.
- Optional DP-9692 dress panel (required for Canadian applications)

1.3 Specifications

AC Power - TB1 of Power Supply Board

MS-9600LS(C) & MS-9600UDLS: 120 VAC, 50/60 Hz, 3.0 amps (L1=Hot, L2=Neutral)

MS-9600LSE & MS-9600UDLSE: 240 VAC, 50 Hz, 1.5 amps (L1=Hot Leg 1, L2=Hot Leg 2)

Wire size: minimum 14 AWG (2.00 mm²) with 600 V insulation

Battery (Sealed Lead Acid Only) - TB2

Maximum Charging Circuit: Normal Flat Charge - 27.6 VDC @ 1.00 amp

Maximum Battery Size: 26 Amp Hour

Minimum Battery Size: 12 Amp Hour

(FACP cabinet holds maximum of two 18 Amp Hour batteries. For greater than 18 Amp Hour up to 26 Amp Hour batteries, use BB26 Battery Box)

For greater than 26 Amp Hour up to 75 Amp Hour batteries, use the CHG-75 Battery Charger and BB26 or BB-55F Battery Box. For greater than 75 Amp Hour up to 120 Amp Hour batteries, use the CHG-120F Battery Charger and BB-55F Battery Box.

Jumper JP3, on the FACP main circuit board, must be removed to disable the FACP battery charger when using the CHG-75 or CHG-120F.

Communication Loop - (Standard) TB8 and (Optional SLC Expander Module) J3

24 VDC nominal, 27.6 VDC maximum

Maximum length - refer to "Wire Requirements" on page 196

Maximum loop current is 400 mA (short circuit) or 100 mA (normal)

Maximum loop resistance is 40 ohms

Supervised and power-limited

Refer to SLC Wiring Manual for wiring information



NOTE: When installing SLC wiring in conduit, each loop must be installed in separate conduit.

Notification Appliance Circuits - TB4

Special Application power

Power-limited circuitry, supervised

NAC wiring requirements, refer to "NAC Wiring" on page 197

Nominal operating voltage: 24 VDC

Current-limit: fuseless, electronic, power-limited circuitry

Maximum signaling current per circuit: 3.00 amps (see Figure 1.1 on page 17)
End-of-Line Resistor: 4.7 k Ω , ½ watt (P/N 71252 UL listed) for NACs
Refer to Device Compatibility Document for listed compatible devices

Two Programmable and One Fixed Output Relay - TB1 & TB5

Contact rating: 2.0 amps @ 30 VDC (resistive), 0.5 amps @ 30 VAC (resistive)
Form-C relays
Refer to Figure 2.5 on page 47 for information on power-limited wiring for relay circuits

Four-Wire Resettable Special Application Smoke Detector Power (24 VDC nominal) - TB3, Terminals 1 (+) & 2 (-)

Maximum ripple voltage: 10 mV_{RMS}
Up to 1.5 amps is available for powering 4-wire smoke detectors (see Figure 1.1)
Power-limited circuit, nonsupervised
Refer to Device Compatibility Document for listed compatible devices

Nonresettable Special Application Power #1 (24 VDC Nominal) - TB3, Terminals 3 (+) & 4 (-)

Maximum ripple voltage: 10mV_{RMS}
Total DC current available from each output is up to 1.5 amps (see Figure 1.1)
Power-limited circuit, nonsupervised

Nonresettable Special Application Power #2 (24 VDC Nominal) - TB3, Terminals 5 (+) & 6 (-)

Maximum ripple voltage: 10mV_{RMS}
Total DC current available from each output is up to 1.5 amps (see Figure 1.1)
Power-limited circuit, nonsupervised

EIA-485 (ACS/ANN-BUS) - TB6

ACS/ANN annunciator connector, Terminal 1 (+) and Terminal 2 (-)

EIA-485 (TERM) - TB7

Terminal Mode annunciator connector, Terminal 5 (In +), 6 (In -), 7 (Out +), 8 (Out -)
Supervised, power-limited.

EIA-232 Serial - TB7

Local serial PC/Printer Connector, Terminal 1 (Transmit), 2 (Receive), 3 (DTR), 4 (Ground)
Non-supervised, power-limited.

1.3.1 Current Availability

The following figure illustrates the maximum current that is possible for each panel circuit and the total current available from the FACP power supply.

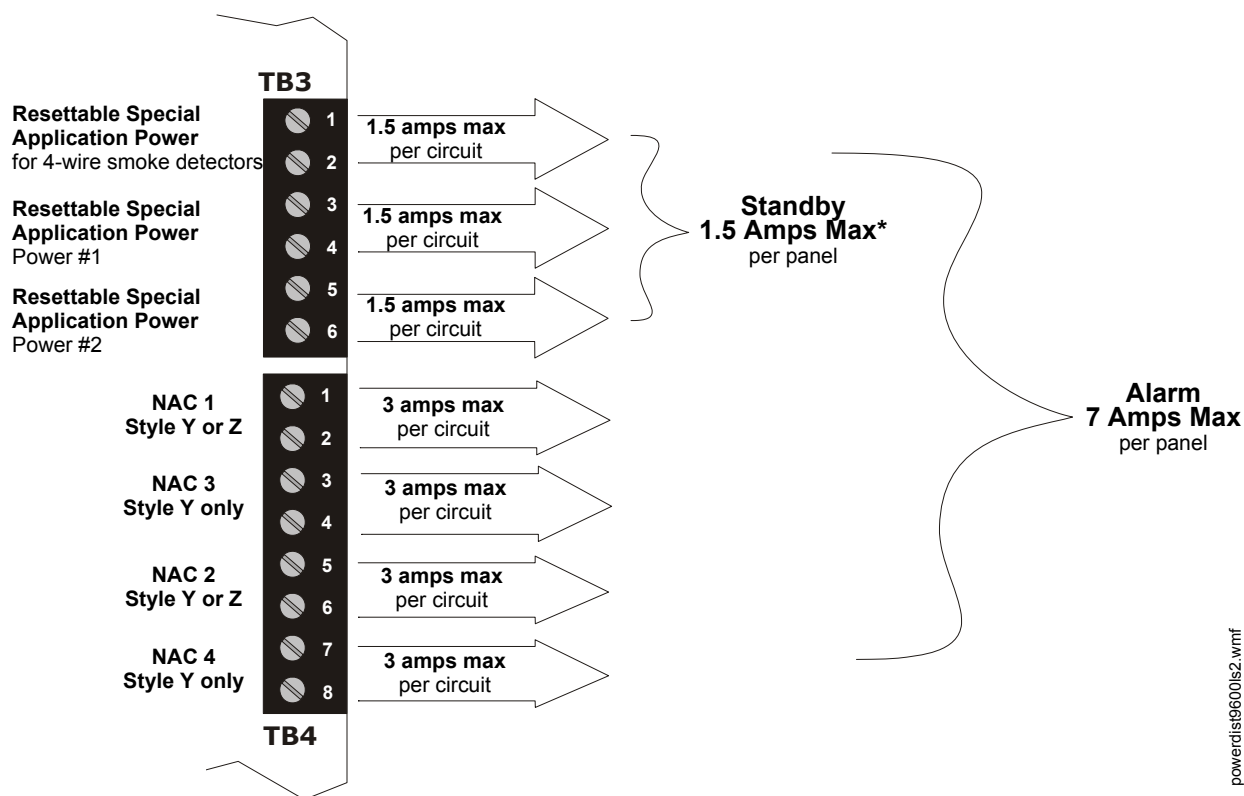

*The combined output current of all Special Applications Power circuits cannot exceed 1.5 amps in standby. Each circuit is capable of delivering the full 1.5 amps individually.

Refer to the battery calculations section for additional information.

Figure 1.1 Current Availability

1.4 Controls and Indicators

LCD Display

The FACP uses an 80-character (4 lines X 20 characters) high viewing angle LCD display. The display includes a long life LED backlight that remains illuminated. If AC power is lost and the system is not in alarm, the LED backlight will turn off to conserve batteries.

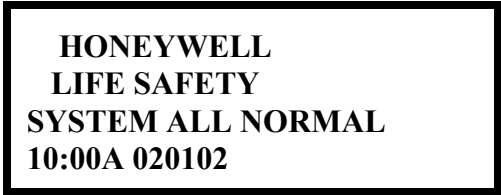

LED Indicators

LED indicators are provided to annunciate the following conditions:

- AC Power (green)
- Fire Alarm (red)
- Supervisory (yellow)
- Trouble (yellow)

- Maintenance/presignal (yellow)
- Alarm Silenced signals (yellow)
- Disabled (yellow)
- Battery fault (yellow)
- Ground fault (yellow)

Key Panel

Mounted on the main circuit board, the key panel includes a window for the LCD display and LED indicators as listed above. The key panel, which is visible with the cabinet door closed, has 25 keys, including a 16 key alpha-numeric pad similar to a telephone keypad.

Function keys:

- Acknowledge/Step
- Alarm Silence
- Drill
- Reset (lamp test)

Service/program keys:

- Keys labeled 1 to 9
- * key
- # key
- 0 (recall) key
- 1st Event key
- Clear key
- Escape key
- Mode key
- Four cursor keys (up, down, left and right)
- Enter key

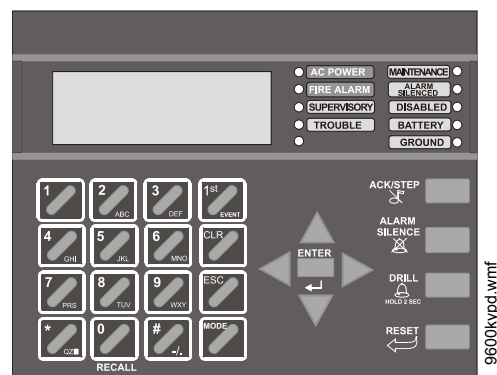

Figure 1.2 Membrane/Display Panel

Local Piezo Sounder

A piezo sounder provides separate and distinct pulse rates for alarm, trouble and supervisory conditions.

1.5 Circuits

SLC Communication Loop

One SLC loop is provided standard on the FACP main circuit board. A second SLC loop is available by plugging the optional SLC module into connector J3 on the main circuit board. SLC loops, configurable for NFPA Style 4, 6 or 7, provide communication to addressable detectors, monitor (initiating device) and control (output device) modules. Refer to the SLC Wiring Manual for information on wiring devices.

Output Circuits

The following output circuits are available on the FACP:

- Special Application Power
 - 24 VDC Resettable (smoke detector power) output - 1.5 amps maximum
 - 24 VDC Nonresettable power output #1 - 1.5 amps maximum
 - 24 VDC Nonresettable power output #2 - 1.5 amps maximum
- 24 VDC Battery Charger (up to 26 AH batteries)

NAC (Notification Appliance Circuits)

Up to four NACs are provided with various programmable features:

- four Style Y (Class B) NACs
- OR**
- two Style Z (Class A) NACs

Relays

One fixed and two fully programmable Form-C dry contact relays are provided. The fixed fail-safe relay monitors system trouble and the two programmable relays are factory default programmed for system alarm and system supervisory. Contacts are rated 2.0 amps @ 30 VDC (resistive) and 0.5 amps @ 30 VAC (resistive). The programmable relays can be programmed for the following operations:

- fire alarm
- trouble
- supervisory
- supervisory auto-resettable
- DACT communication failure
- process monitor
- process monitor auto-resettable
- hazard alert
- medical alert
- AC loss

Auxiliary Trouble Inputs

Auxiliary Trouble Inputs can be connected to trouble bus outputs from auxiliary equipment, such as power supplies or normally-open dry contacts of a trouble relay to allow monitoring by the FACP.

1.6 Components

Main Circuit Board

The main circuit board contains the system's CPU and other primary components and wiring interface connectors. Optional modules plug in and are mounted to the main circuit board. The circuit board is delivered mounted to a chassis which must be mounted to the backbox. Refer to the circuit board illustration on Page 10.

FLPS-7 Power Supply

The FLPS-7 Power Supply is provided as a separate module which is delivered mounted to a chassis which must be mounted to the backbox and connected to the main circuit board.

Cabinet

The FACP cabinet is red with a navy blue front overlay.

The backbox provides space for two batteries (up to 18 Amp Hour). Ample knockouts are provided for system wiring. Also available is an optional dress panel DP-9692, which mounts to the inside of the cabinet (required by ULC for Canadian applications).

Batteries

Batteries must be sealed lead acid type. The FACP cabinet provides space for two batteries (up to 18 Amp Hour). Batteries larger than 18 Amp Hour up to 26 Amp Hour require use of the BB-26 or similar UL listed battery cabinet. The CHG-75 can be used for charging 26 to 75 AH batteries and



the BB-26 can be used for housing the batteries. The CHG-120F can be used for charging 26 to 120 AH batteries and the BB-55F can be used for housing the batteries. Batteries must be ordered separately.

1.6.1 Intelligent Addressable Detectors: Newer Series

Intelligent, addressable detectors provide information to the control panel on an SLC Signaling Line Circuit (refer to the SLC Wiring Manual for detailed information on device installation, wiring and operation). This allows the control panel to continually process the information to determine the status (alarm, trouble, maintenance or normal) of each detector. Each detector responds to an SLC address that is set in the detector head using built-in rotary decimal switches with the ability to select up to 159 addresses. Note that a blinking LED on an intelligent detector indicates communication between the detector and the control panel.

These devices (350 Series or newer) can operate in CLIP mode (Classic Loop Interface Protocol) or LiteSpeed mode to provide a quicker response. They are also compatible with older 300 Series devices. If a mix of old and new series devices are installed on the same loop, that loop must be programmed to operate in CLIP mode. Refer to the SLC Wiring Manual for a complete list of compatible addressable detectors.

1.6.2 Intelligent Addressable Modules: Newer Series

The newer series of Control Modules and Monitor Modules provide an interface between the control panel and conventional notification and initiating devices. Each module can be set to respond to an address with built-in rotary switches with the ability to select up to 159 addresses (a tab on the address switch must be broken off to use addresses 100-159). A blinking LED on a monitor module indicates communication between the module and the control panel.

These devices (350 Series or newer) can operate in CLIP mode (Classic Loop Interface Protocol) or LiteSpeed mode to provide a quicker response. They are also compatible with older 300 Series devices. If a mix of old and new series devices are installed on the same loop, the loop must be programmed to operate in CLIP mode. Refer to the SLC Wiring Manual for a complete list of compatible addressable modules. *Refer to the Device Compatibility Document for a list of approved notification and initiating devices.*

1.6.3 300 Series Intelligent Addressable Devices

Fire•Lite's 300 Series Intelligent Addressable Devices are fully compatible with the MS-9600LS FACP. The FACP must be configured for CLIP Mode operation if the control panel is installed in an existing system with 300 Series devices. The address of 300 Series devices cannot be set above 99. *Refer to the SLC Wiring Manual for a complete list of compatible addressable devices.*

1.6.4 Addressable Device Accessories

End-of-Line Resistor Assembly P/N R-47K

The 47 K Ω End-of-Line Resistor assembly (P/N: R-47K) is used to supervise the MMF-300, MDF-300, MMF-301 and CMF-300 module circuits. The 3.9 K Ω End-of-Line Resistor assembly is used to supervise the MMF-302 module circuit. The resistors are included with each module.

Power Supervision Relay

The UL listed End-of-Line power supervision relay (P/N: EOLR-1) is used to supervise the power to 4-wire smoke detectors and notification appliances.

N-ELR Mounting Plate

The N-ELR is a single End-of-Line resistor plate which is required for use in Canada. An ELR, which is supplied with each module and fire alarm control panel, is mounted to the ELR plate. Resistors mounted to the N-ELR plate can be used for the supervision of a monitor and control module circuit.

1.7 Optional Modules

The FACP main circuit board includes option module connectors for the following modules:

4XTMF Transmitter Module

The 4XTMF provides a supervised output for local energy municipal box transmitter, alarm and trouble reverse polarity. It includes a disable switch and disable trouble LED. A jumper on the module is used to select an option which allows the reverse polarity circuit to open with a system trouble condition if no alarm condition exists. The module plugs into connectors J10 and J11 which are located near the top left of the main circuit board. When the 4XTMF module is installed, Jumper JP6, on the main circuit board, must be cut to allow supervision of the module.

SLC-2LS Expander Module

The SLC-2LS Expander Module allows expansion of the FACP from one SLC circuit to two SLC circuits. The module plugs into connector J3 which is located in the lower right corner of the main circuit board. The wiring for the second SLC connects to terminals located on the expander module.

DACT-UD2 Digital Alarm Communicator/Transmitter

The DACT-UD2 is used to transmit system status to UL-listed Central Station receivers via the public switched telephone network. All circuitry and connectors are contained on a compact module which plugs into connector J2, which is located near the bottom center of the main circuit board.

The MS-9600UDLS/E is provided with a factory installed DACT-UD2. Refer to “DACT-UD2 Installation” on page 52 and to the DACT-UD2 manual, which is included with the FACP, for DACT-UD2 wiring and programming information.

IPDACT - Internet Protocol DACT

The IPDACT is a compact, Internet Protocol Digital Alarm Communicator/Transmitter designed to allow FACP status communication to a Central Station via the internet. No telephone lines are required when using the IPDACT. Using Contact ID protocol from the FACP, the IPDACT converts the standard DACT phone communication to a protocol that can be transmitted and received via the internet. It also checks connectivity between the FACP and Central Station. Refer to the IPDACT Product Installation Document P/N 53109 for additional information.

1.8 Accessories

1.8.1 PS-Tools Programming Utility

The PS-Tools Programming Utility can be used to locally or remotely program the FACP directly from most IBM compatible computers (PC), running Windows™ XP or newer. FACP program files can also be created and stored on the PC and then downloaded later to the control panel. The P/N: PK-CD Kit includes the FACP Windows-based Programming Utility software on CD-ROM with on-line help file. A standard USB cable with male-A to male-B connectors, which must be purchased separately, is required by the MS-9600UDLS for local connection of the PC to the USB port J4 on the DACT-UD2. The MS-9600LS requires connection to the Serial Port on FACP connector TB7. Remote programming requires that the PC have a 2400 baud or faster modem.

Important: Remote modification of FACP programming requires that the panel be enabled for remote download (refer to the DACT-UD2 manual). Remote interrogation of panel programming, history logs, detector status, etc., is possible without enabling the remote download option.

1.8.2 Dress Panel: DP-9692

A DP-9692 dress panel is available for the FACP (required for Canadian installations). The dress panel restricts access to the system wiring while allowing access to the key panel.

The MS-9600LSC has received ULC approval. ULC approval is contingent on the proper installation of the dress panel which is provided with the FACP

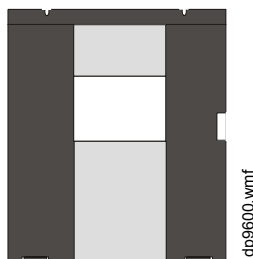

1.8.3 TR-CE Trim Ring

An optional TR-CE trim ring is available for semi-flush mounting the FACP backbox.

1.8.4 Battery Box

BB-26

The BB-26 battery box may be used to house up to two 26 AH batteries and the CHG-75 Battery Charger. The battery box is red and is provided with knockouts.

BB-55F

The BB-55F battery box may be used to house two 26 AH batteries, two 60 AH batteries or one 100 AH battery. When the CHG-120 is mounted in the BB-55F, two 26 AH or one 60 AH battery may also be housed in the battery box.

1.8.5 Battery Charger

CHG-75 Battery Charger

The CHG-75 is capable of charging up to 75 AH lead-acid batteries with the MS-9600LS FACP. The FACP battery charger must be disabled when using the CHG-75. The charger and up to 26 AH batteries can be housed in the BB-26 battery box. Larger batteries and the charger can be housed in the BB-55F battery box which can be mounted up to 20 feet away from the control panel. Refer to the CHG-75 Manual for additional information.

CHG-120 Battery Charger

The CHG-120 is capable of charging up to 120 AH lead-acid batteries with the FACP. The FACP battery charger must be disabled when using the CHG-120. The batteries and charger can be housed in the BB-55F battery box which can be mounted up to 20 feet away from the control panel. Note that when using the BB-55F for housing the charger and batteries greater than 26AH, multiple BB-55Fs are required. Refer to the *CHG-120 Manual* for additional information.

1.8.6 New ANN-BUS Annunciators/Devices



NOTE: Refer to “Canadian Application” on page 200 for specific Canadian requirements.



WARNING: RISK OF ELECTRICAL SHOCK AND EQUIPMENT DAMAGE

DISCONNECT ALL SOURCES OF POWER (AC AND DC) BEFORE INSTALLING OR REMOVING ANY MODULES OR WIRING.

The legacy ACS annunciators may **not** be used if new ANN-BUS annunciators are being used due to incompatible serial communication protocols.

A variety of optional devices can be connected to the FACP EIA-485 ANN-BUS communication circuit. Compatible devices include:

- ANN-80 LCD Annunciator
- ANN-S/PG Serial/Parallel Printer Interface Module
- ANN-I/O LED Driver Module
- ANN-LED Annunciator Module (alarm, trouble, supervisory LEDs)
- ANN-RLED Annunciator Module (red alarm LEDs only)
- ANN-RLY Relay Module

ANN-BUS Wiring

This section contains information on calculating ANN-BUS wire distances and the types of wiring configurations (Class B).

■ Calculating Wiring Distance for ANN-BUS Modules

The following instructions will guide the installer in determining the type of wire and the maximum wiring distance that can be used with FACP ANN-BUS accessory modules.

To calculate the wire gauge that must be used to connect ANN-BUS modules to the FACP, it is necessary to calculate the total worst case current draw for all modules on a single 4-conductor bus. The total worst case current draw is calculated by adding the individual worst case currents for each module. The individual worst case values are shown in the following table:

Model Number	Worst Case Current Draw ¹
ANN-80 LCD Annunciator	0.040 amps
ANN-S/PG Serial/Parallel Printer Interface Module	0.040 amps
ANN-I/O LED Driver Module	0.200 amps
ANN-(R)LED Annunciator Module	0.068 amps
ANN-RLY Relay Module	0.075 amps

¹ Total worst case current draw on a single ANN-BUS cannot exceed 0.5 amp. If current draw exceeds 0.5 amps, refer to “Powering ANN-BUS Devices from Auxiliary Power Supply” on page 26.

After calculating the total worst case current draw, Table 1.1 specifies the maximum distance the modules can be located from the FACP on a single wire run. The table ensures 6.0 volts of line drop maximum. In general, the wire length is limited by resistance, but for heavier wire gauges,

capacitance is the limiting factor. These cases are marked in the chart with an asterisk (*). Maximum length can never be more than 6,000 feet (1,800 m), regardless of gauge used. The formula used to generate this chart is shown in the note below.

Wiring Distance: ANN-BUS Modules to FACP				
Total Worst Case Current Draw (amps)	22 Gauge	18 Gauge	16 Gauge	14 Gauge
0.100	1,852 ft.	4,688 ft.	* 6,000 ft.	*6,000 ft.
0.200	926 ft.	2,344 ft.	3,731 ft.	5,906 ft.
0.300	617 ft.	1,563 ft.	2,488 ft.	3,937 ft.
0.400	463 ft.	1,172 ft.	1,866 ft.	2,953 ft.
0.500	370 ft.	938 ft.	1,493 ft.	2,362 ft.

Table 1.1 Wiring Distances

The following formulas were used to generate the wire distance chart:

$$\text{Maximum Resistance (Ohms)} = \frac{6.0 \text{ volts}}{\text{Total Worst Case Current Draw (amps)}}$$

$$\text{Maximum Wire Length (feet)} = \frac{\text{Maximum Resistance (Ohms)}}{\text{Rpu}} * 500$$

(6,000 feet maximum)

where: Rpu = Ohms per 1,000 feet for various Wire Gauges (see table below)

Wire Gauge	Ohms per 1,000 feet (Rpu)
22	16.2
18	6.4
16	4.02
14	2.54

Exception: When using the ANN-RLY module, the installer must ensure that the maximum 24VDC power line drop does not exceed 0.3 volts. This results in the following wiring limitations:

Wire Gauge	Maximum Wire Length
18	312 feet
16	497 feet
14	787 feet
12	1,250 feet

Wiring Distance Calculation Example:

Suppose a system is configured with the following ANN-BUS modules:

- 3 ANN-80 Remote Fire Annunciators
- 1 ANN-S/PG Serial/Parallel Printer Interface Module
- 1 ANN-I/O LED Driver Module

The total worst case current is calculated as follows:

ANN-80 Current Draw	= 3 X 0.040 amps	= 0.120 amps
ANN-S/PG Current Draw	= 1 X 0.040 amps	= 0.040 amps
ANN-I/O Current Draw	= 1 X 0.200 amps	= 0.200 amps
Total Worst Case Current Draw		= 0.360 amp

Using this value and referring to the Wiring Distance Table 1.1 on page 24, it can be found that the available options are:

- 463 feet maximum using 22 Gauge wire
- 1,172 feet maximum using 18 Gauge wire
- 1,866 feet maximum using 16 Gauge wire
- 2,953 feet maximum using 14 Gauge wire

■ **Wiring Configuration**

Figure 1.3 illustrates the wiring between the FACP and ANN-BUS devices.

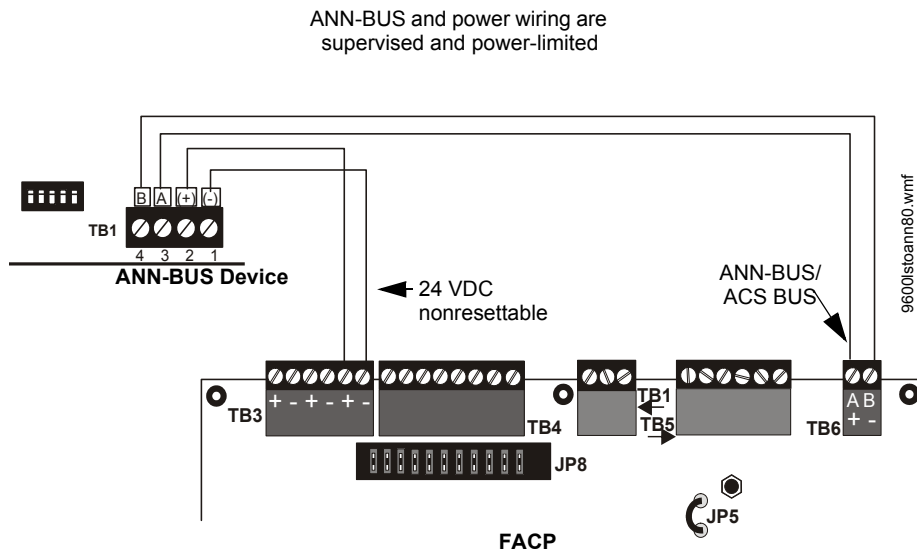

Figure 1.3 FACP wiring to ANN-BUS Device

■ Powering ANN-BUS Devices from Auxiliary Power Supply

Figure 1.4 illustrates the powering of ANN-BUS devices from an auxiliary power supply such as the FCPS-24FS6/8, when the total ANN-BUS power requirement exceeds the capability of the FACP's DC Power Output circuit.

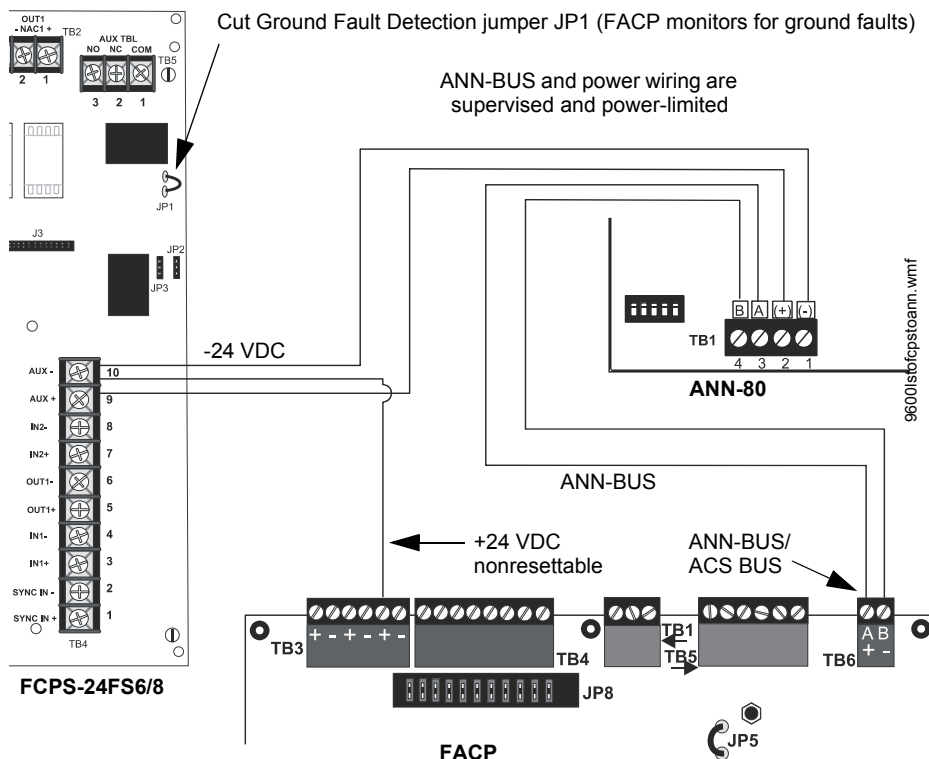

Figure 1.4 Powering ANN-BUS Devices from FCPS-24FS6/8

ANN-BUS Device Addressing

Each ANN-BUS device requires a unique address (ID Number) in order to communicate with the FACP. A 5-position DIP switch on each device is used to set this address. The address set for these devices must also be programmed at the FACP for the specific device (refer to the programming section titled “ANN-BUS Options” on page 121).

A maximum of 8 devices can be connected to the FACP ANN-BUS communication circuit. Device addresses do not need to be sequential and can be set to any number between 01 and 08. Note that 00 is not a valid address. The following table shows the DIP switch setting for each address.



NOTE: Address (ID Number) DIP switches on some devices may have more than 5 switch positions. Unless otherwise specified in the documentation supplied with each device, switch positions 6 and above must be set to **OFF**.

Address	Switch 5 ¹	Switch 4	Switch 3	Switch 2	Switch 1
not valid	OFF	OFF	OFF	OFF	OFF
01	OFF	OFF	OFF	OFF	ON
02	OFF	OFF	OFF	ON	OFF
03	OFF	OFF	OFF	ON	ON
04	OFF	OFF	ON	OFF	OFF
05	OFF	OFF	ON	OFF	ON
06	OFF	OFF	ON	ON	OFF
07	OFF	OFF	ON	ON	ON
08	OFF	ON	OFF	OFF	OFF

1 Switch 5 must be set to **OFF** for ANN-BUS devices to be recognized.

ANN-80 Remote Fire Annunciator

The ANN-80(-W) Annunciator is a compact, 80 character, backlit LCD remote fire annunciator. It mimics the display on the control panel and will announce device type, point alarm, trouble or supervisory condition, zone assignment plus any custom alpha labels programmed into the FACP. The annunciator also provides system status LEDs to display AC Power, Alarm, Trouble, Supervisory and Alarm Silenced conditions. Additionally, the annunciator is capable of remotely performing critical system functions such as Acknowledge, Silence, Reset and Drill. Communication between the ANN-80 and FACP is accomplished over a two wire RS-485 serial interface employing the ANN-BUS communication format. The devices are powered, via two additional wires, from either the host FACP or remote UL-listed, filtered, power supply.

The function buttons, keyswitch and piezo sounder may be individually enabled and disabled through the FACP software. Refer to “ANN-BUS Options” on page 121 for a description of this feature and programming information.

Note that if the keyswitch is enabled and remains in the unlocked position for more than two minutes without any buttons being pressed on the annunciator, a trouble indication will be announced.

■ Specifications

- Operating Voltage Range: 18 VDC to 28 VDC
- Current Consumption @ 24 VDC nominal (filtered and nonresettable):
 - Normal/Standby (no activity): 37.0 mA
 - Trouble: 39.0 mA
 - Alarm: 40.0 mA
 - AC Fail (not backlit): 15.0 mA
- For use indoors in a dry location

■ Installation

Ensure that all power (AC and DC) has been removed from the FACP before installing the annunciator.

■ Opening/Closing Annunciator

The following procedure details the steps used to open the annunciator in order to access the terminal block and DIP switches (refer to Figure 1.5 on page 28):

1. Turn the key switch to the ON (Unlocked) position by turning the key counter-clockwise.
2. Push in the snap latch located on the right side of the unit while pulling the cover open.
3. To close the cover, make certain the key switch is in the ON (Unlocked) position. Swing the cover closed, snapping it shut.
4. Turn the key switch to the OFF (Locked) position by turning clockwise and remove the key.

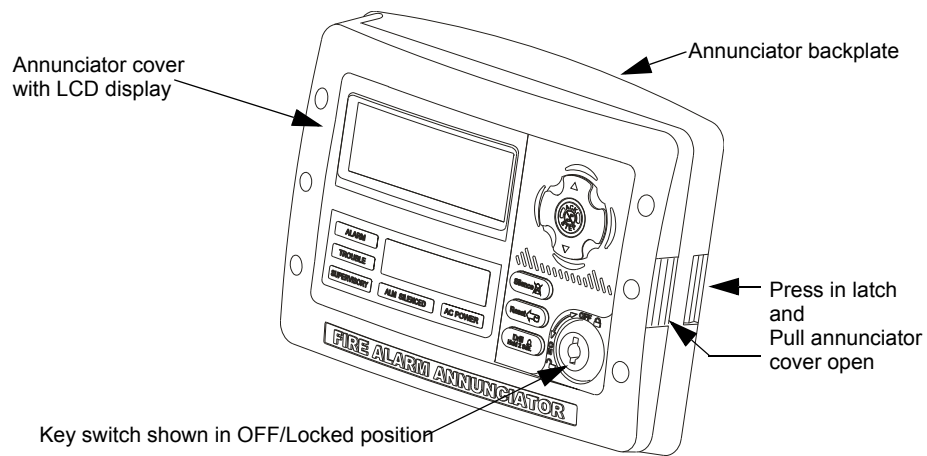

ann80_iso.wmf

Figure 1.5 ANN-80

■ **Mounting**

The ANN-80 can be surface or semi-flush mounted to a single, double or 4” square electrical box. Select and remove the appropriate knockout(s), pull the necessary wires through the knockouts and mount the annunciator in or on the wall depending on the type of installation desired.

The ANN-SB80KIT(-R/-B/-W) is an available mounting kit for the ANN-80 annunciator. The kit comes with a surface backbox and surface wedge for angled viewing. The two pieces can be used separately or can be stacked together.

The ANN-80 cover must be attached to the annunciator backplate before mounting the annunciator to the electrical box/wall. The cover cannot be reattached or removed after the annunciator has been mounted.

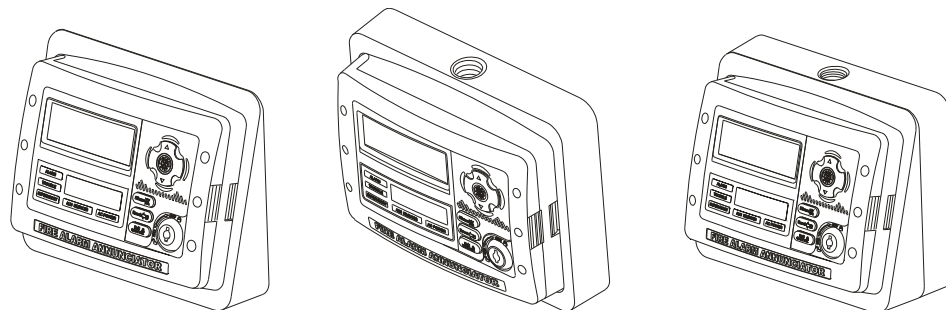

aann80kitmount.wmf

Annunciator mounted on surface wedge from the ANN-SB80KIT

Annunciator mounted on surface backbox from the ANN-SB80KIT

Annunciator mounted on stacked surface wedge and backbox from the ANN-SB80KIT

■ Wiring ANN-80 to FACP

The following steps can be used as a guide to wire the annunciator. Make certain all power has been removed from the FACP prior to annunciator installation.

1. Route wires from hole in backplate, through wiring channel and then to ANN-80 terminal block TB1.

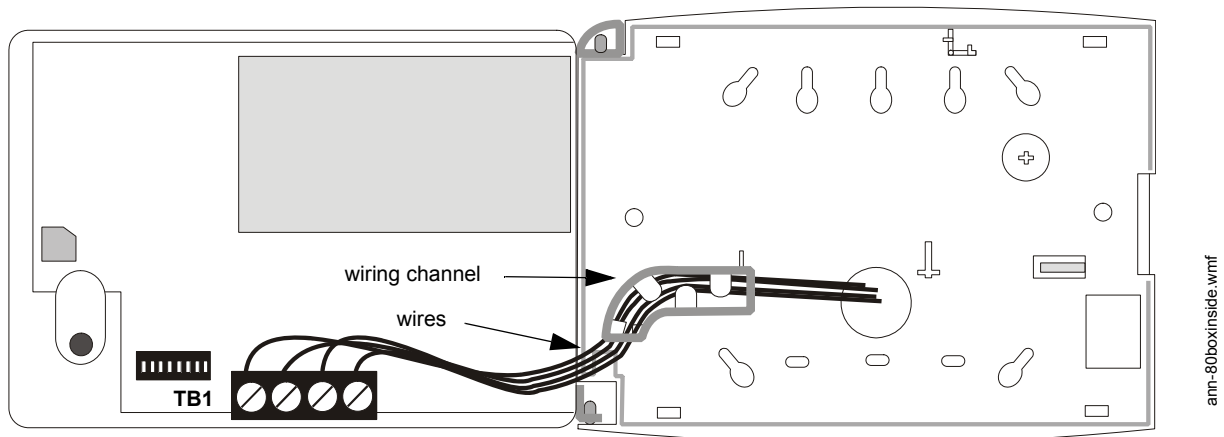

2. Remove appropriate amount of wire insulation.
3. Connect the wiring from the FACP ANN-BUS to annunciator TB1 terminals 3 (A) & 4 (B). Make certain to connect A to A and B to B.
4. If appropriate, connect the wiring going to the next device on the ANN-BUS to TB1 terminals 3 & 4. Make certain to connect A to A and B to B.
5. Connect the wiring from the 24 VDC power source to annunciator TB1 terminals 1 (-) & 2 (+). Make certain to observe proper polarity.
6. If appropriate, connect the power wiring going to the next device to terminals 1 (-) & 2 (+). Make certain to observe proper polarity.
7. After all connections are made, remove extra wire from inside of annunciator by dressing it neatly through wire channel, with any excess wire pushed back through hole into electrical box.

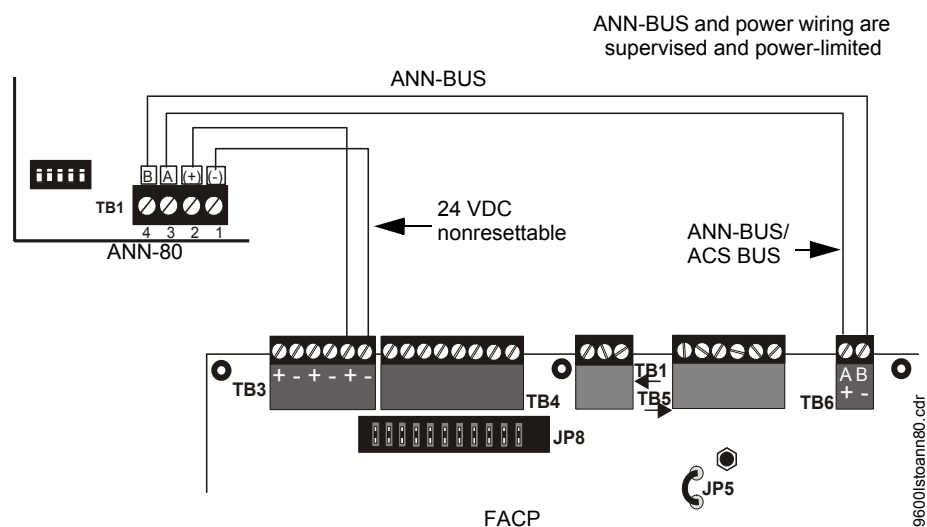

Figure 1.6 ANN-80 Wiring to FACP

The following table shows the ANN-80 connections to the FACP

FACP	ANN-80 (TB1)
Terminal GND (-) on TB3	Terminal 1 (-)
Terminal PWR (+)TB3	Terminal 2 (+)
Terminal ACS on TB6	Terminal 3 (A)
Terminal ACS on TB6	Terminal 4 (B)

Programming

Following installation and wiring of the ANN-80 LCD annunciator to the FACP, the annunciator must be added to the system via FACP programming. Refer to the programming section titled “ANN-BUS Options” on page 121 in this manual for detailed programming information. Select the LCD option for programming.

Trouble Response

If the ANN-80 is installed but the ANN-BUS is not enabled at the FACP, the ANN-80 will indicate a trouble condition by NOT turning on its AC Power indicator. The LCD will also display *Key Bus Trouble* and the piezo will sound approximately once every 10 seconds. Note that the FACP will provide no indication of an ANN-80 trouble.

To clear the ANN-80 trouble condition, enable the ANN-BUS and program the address corresponding to the address set on the ANN-80 at the FACP.

If the Keyswitch on the ANN-80 is left in the unlocked position for more than 2 minutes, a trouble condition will be indicated at the FACP.

ANN-S/PG Serial/Parallel Interface Installation

The ANN-S/PG Serial/Parallel Interface module allows the connection of a remote serial or parallel printer to the FACP for a real-time log of system events, detector status reports and event history. The module is provided with a plastic enclosure for surface mounting. Proceed with the installation as described in the following:

1. Ensure that all power (AC and DC) has been removed from the FACP.
2. Connect the ANN-S/PG to the FACP as illustrated in Figure 1.7.

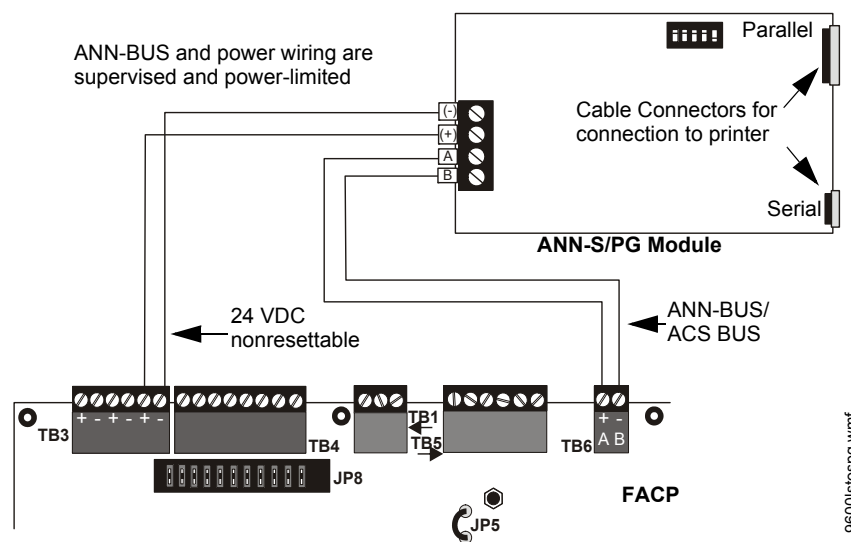

Figure 1.7 ANN-S/PG Connection to FACP

3. Using the DIP switches on the back of the ANN-S/PG module, assign an ID number (address) to the module.

4. Select the address and configuration options for the ANN-S/PG module as described in the Programming section of this manual (refer to “ANN-BUS Options” on page 121). Note that the Auto-configure feature allows the programmer to quickly bring all installed ANN-BUS modules online (refer to “Auto-Configure” on page 131).
5. Connect a printer to the ANN-S/PG Parallel or Serial connectors (refer to Figure 1.7). Only one printer can be connected.

■ Specifications

- Operating Voltage: 24 VDC
- Current (Alarm and Standby): 45 mA
- Ambient Temperature: 32°F to 120°F (0°C to 49°C)
- Max. Wiring Distance from FACP: 6,000 ft. (1,800 m)
- Mounting: Surface
- Dimensions: 6”W x 7-3/4”H x 1-7/16”D (15.2 cm W x 19.7 cm H x 3.7 cm D)
- For indoor use in a dry location only

■ PRN 6F Printer Installation

When connected to the FACP via the ANN-S/PG module, the PRN-6F prints the status changes within the control panel and time-stamps the printout with the time of day and date that the event occurred. It provides 80 columns of data on standard 9” x 11” tractor-feed paper. This section contains information on connecting a printer to the control panel and setting the printer options.

Connecting PRN-6F Printer

Remote printers require a primary AC power source. If required for the fire alarm system configuration (for example, a Proprietary Fire Alarm System), a remote printer requires a secondary power source (battery backup). Since a secondary power source is not provided as a standard feature, a separate UL-listed Uninterruptible Power Supply (UPS) should be used. The building emergency power supply may be used, as long as it meets the power continuity requirements of NFPA 72. Refer to NFPA 72 for further details.

Connect the remote printer to the FACP via the ANN-S/PG module using a standard DB-25 cable. One end of the cable will plug into the DB-25 connector on the PRN printer and the other end plugs into the parallel connector on the ANN-S/PG module. Note that the 9-pin DB-9 port on the ANN-S/PG is used to connect a serial printer. The 25-pin port is used for a Centronics parallel printer cable. Connect either a serial or parallel printer, but not both at the same time.

Setting Printer Options

Refer to the documentation supplied with the PRN-6F printer for instructions on using the printer menu controls. Set the printer options (under the menu area) as shown in the following table:

Option	Setting	Option	Setting
Font	HS Draft	CPI	10CPI
LPI	6 LPI	Skip	0.5
ESC Character	ESC	Emulate	Epson FX-850
Bidirectional Copy	ON	I/O	
CG-TAB	Graphic	Buffer	40K
Country	E-US ASCII	Serial	
Auto CR	OFF	Baud	9600 or 2400
Color Option	Not Installed	Format	7 Bit, Even, 1 Stop
Formien		Protocol	XON/XOFF
Lines	6LPI=60	Character Set	Standard

Table 1.2 PRN-6F Setup Options

Standard	Exec 10.5	Sl.Zero	On
		Auto LF	On
		PAPER	
		BIN 1	12/72"
		BIN 2	12/72"
		SINGLE	12/72"
		PUSH TRA	12/72"
		PULL TRA	12/72"
		PAP ROLL	12/72"

Table 1.2 PRN-6F Setup Options

ANN-I/O LED Driver Module*

The ANN-I/O is an LED driver module that can be used in a wide variety of applications, including as an interface with most customized graphic annunciators. The ANN-I/O can drive up to 40 LEDs. The module is provided with a plastic enclosure for mounting inside the annunciator or accessory box. The following sections describe hardware installation. Refer to the section titled “ANN-BUS Options” on page 121 for programming information.

*In Canada, the color red must be used to indicate active alarm inputs. Yellow indicates supervisory, burglary or trouble signals. Green indicates the presence of power or an activated output.

■ **ANN-I/O Board Layout**

Figure 1.8 illustrates the ANN-I/O board showing locations of screw terminals for connection to the FACP, pin connectors for connecting LEDs and the DIP switch for selecting the ANN-BUS ID number.

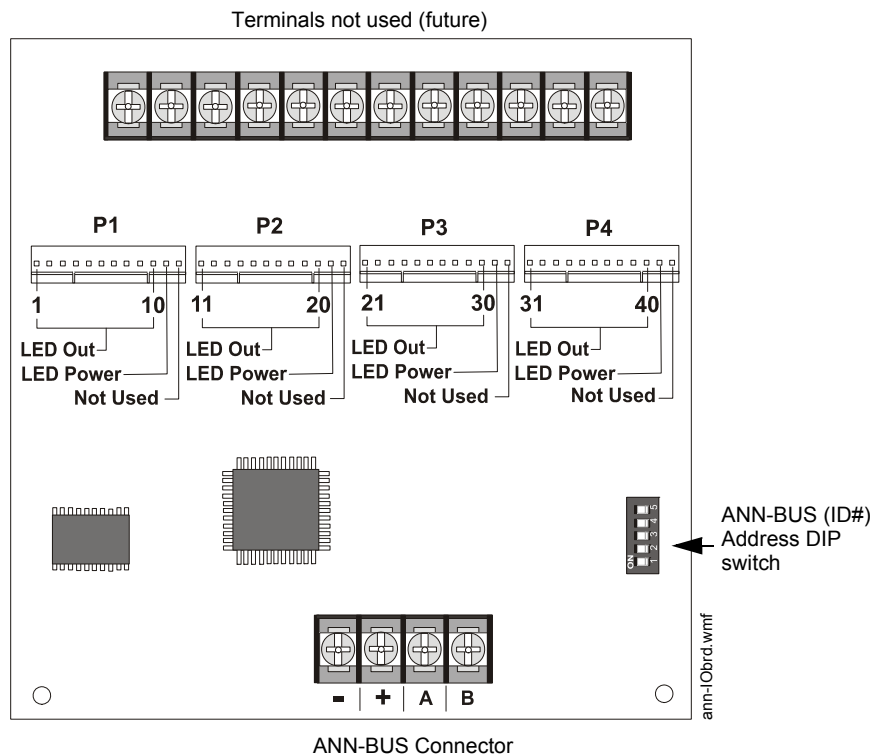

Figure 1.8 ANN-I/O Board Layout

■ Specifications

- Max. ANN-BUS Voltage: 28 VDC
- Max. Current:
 - Alarm: 200 mA
 - Standby: 35 mA
 - Each LED: 10 mA
- Operating Temperature: 32°F to 120°F (0°C to 49°C)
- For indoor use in a dry location only

■ ANN-I/O Connection to FACP

The ANN-I/O connects to the FACP via the ANN-BUS as illustrated in Figure 1.9. After the ANN-I/O is connected to the panel, it must be added to the system via FACP programming. Refer to the section titled “ANN-I/O Options” on page 123.

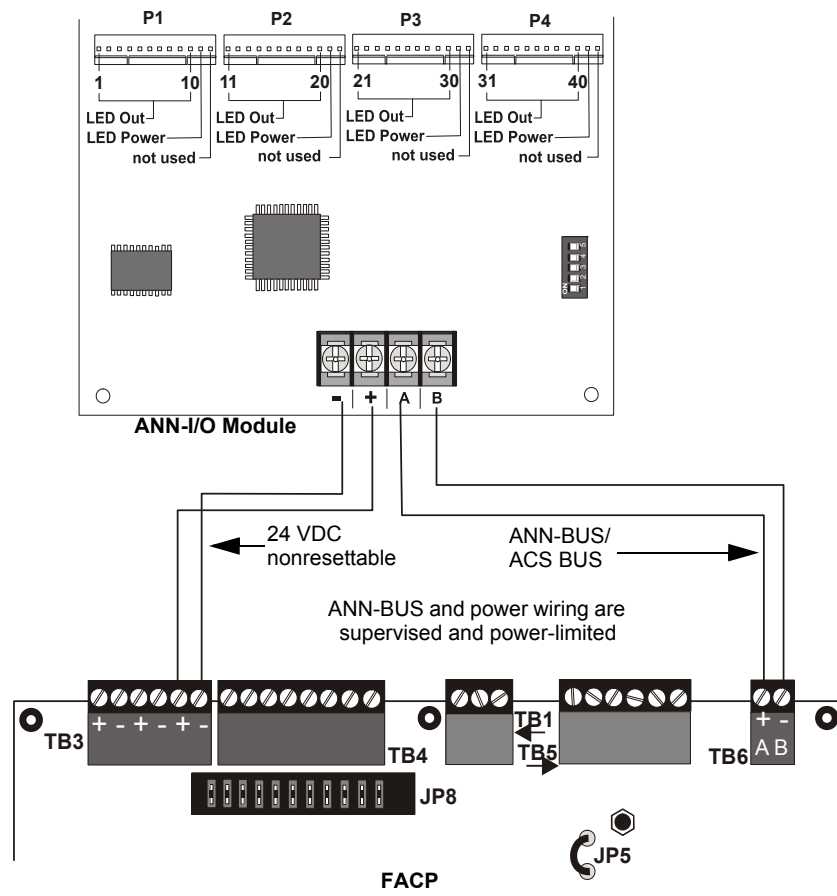

Figure 1.9 ANN-I/O Connection to FACP

■ ANN-I/O Module LED Wiring

There are four 12-pin connectors on the ANN-I/O module for connecting LEDs. Each set of 10 LEDs get their power from Pin 11 of the corresponding connector. Internal resistors are sized so that there is approximately 10 mA of current for each LED. No series resistors are required. Refer to the programming section titled “ANN-I/O Options” on page 123 of this manual.

The LEDs are wired as illustrated in Figure 1.10. Note that the illustration depicts only connectors P1 and P2. Wiring is identical for P3 (LEDs 21-30) and P4 (LEDs 31-40).

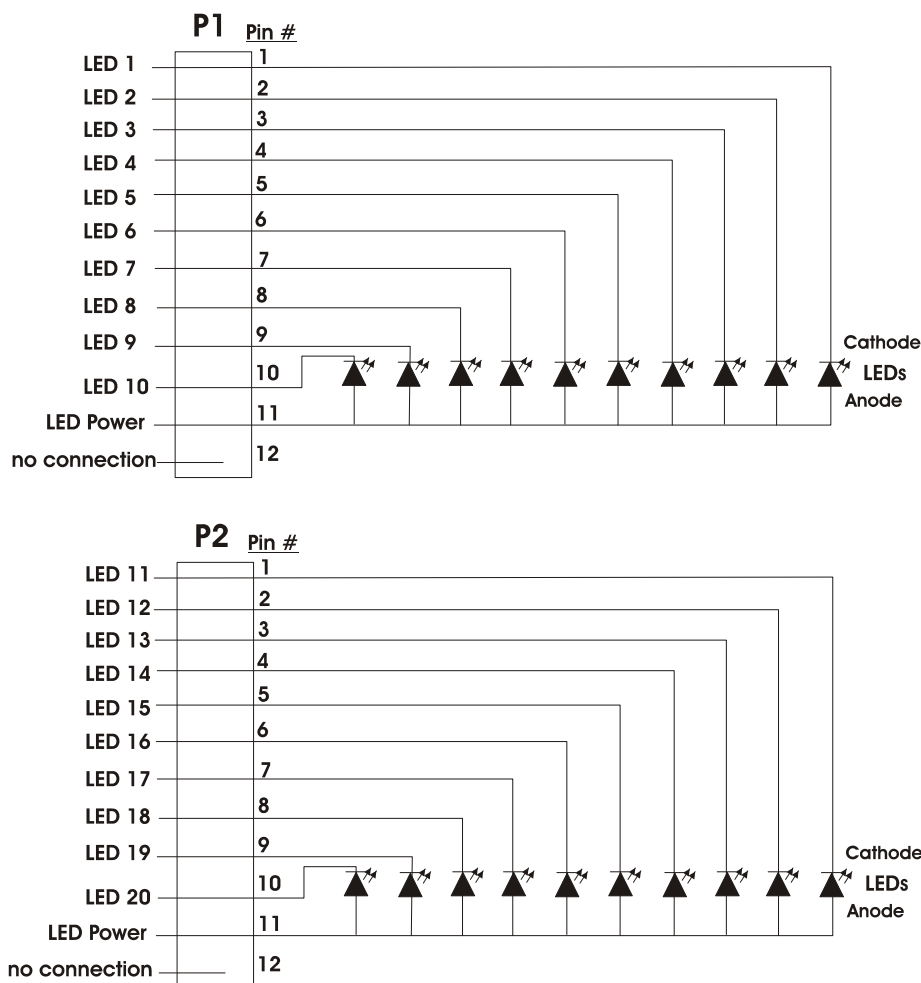
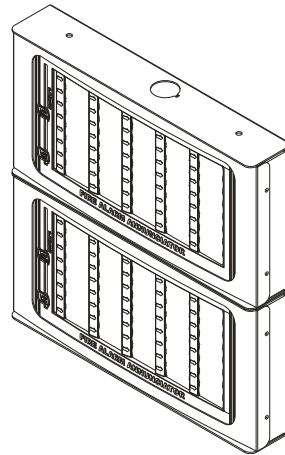

Figure 1.10 ANN-I/O Board Layout

ANN-LED Annunciator Module*

The ANN-LED and ANN-RLED annunciator modules provide LED annunciation of general system faults and input zones/points when used with a compatible FACP. The ANN-LED module provides alarm (red), trouble (yellow) and supervisory (yellow) indication for up to ten input zones or addressable points. The ANN-LEDR provides alarm (red) indication for up to 30 input zones or addressable points. Multiple ANN-(R)LED modules may be used for full system coverage.

*In Canada, the color red must be used to indicate active alarm inputs. Yellow indicates supervisory, burglary or trouble signals. Green indicates the presence of power or an activated output.



ann-ledistacked.wmf

Figure 1.11 ANN-LEDs (shown in possible stacked configuration)

■ Specifications

- Max. ANN-BUS Voltage: 24 VDC
- Max. Current:
 - Alarm: 68 mA
 - Standby: 28 mA
- Operating Temperature: 32° F to 120° F (0° C to 49° C)
- For indoor use in a dry location only

■ Mounting/Installation

Refer to the documentation supplied with the ANN-LED module for mounting information.

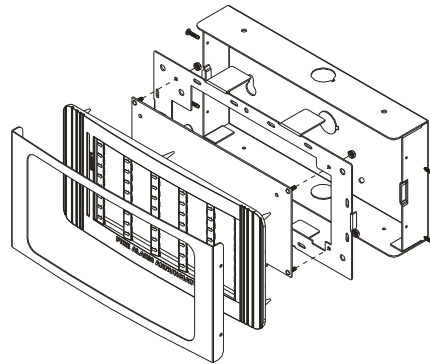

ann-led.wmf

Figure 1.12 Exploded View of ANN-LED

■ ANN-LED Board Layout and Connection to FACP

Figure 1.13 illustrates the ANN-LED board showing locations of screw terminals for connection to the FACP and the DIP switches for selecting the ANN-BUS ID number.

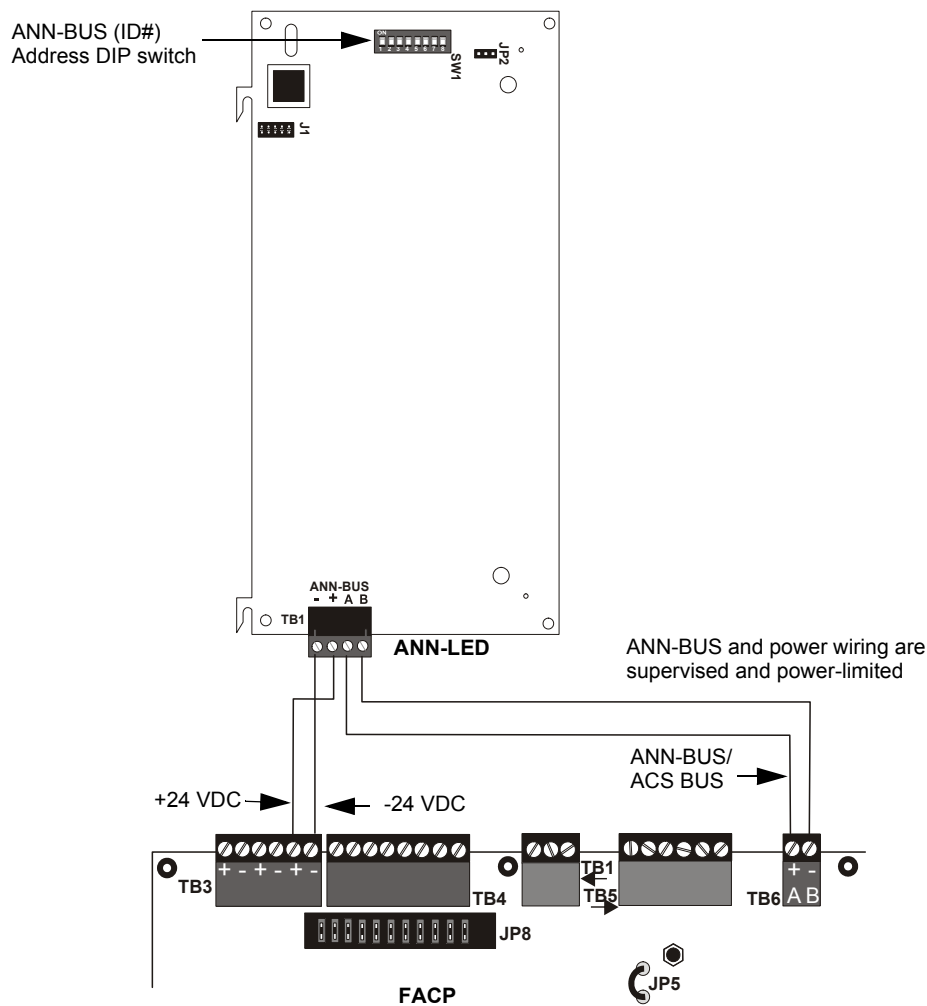

Figure 1.13 ANN-LED Connection to FACP

ANN-RLY Annunciator Module

The ANN-RLY relay module provides 10 programmable Form-C relays when used with a compatible FACP.

■ Specifications

- Operating Voltage: 24 VDC
- Max. Current:
- Alarm: 75 mA
- Standby: 15 mA
- Relay Contact Ratings
- 2 amps @ 30 VDC (resistive)
- 0.5 amps @ 30 VAC (resistive)
- Operating Temperature: 32° F to 120° F (0° C to 49° C)
- For indoor use in a dry location only

■ **Mounting/Installation**

The ANN-RLY relay module can be mounted inside the FACP main circuit board chassis or inside the ROME Series enclosure. Refer to the *ANN-RLY Installation Document #53033* for instructions on chassis mounting or to the *ROME Series Installation Document #53530* for mounting in the separate backbox.

FACP Chassis Installation

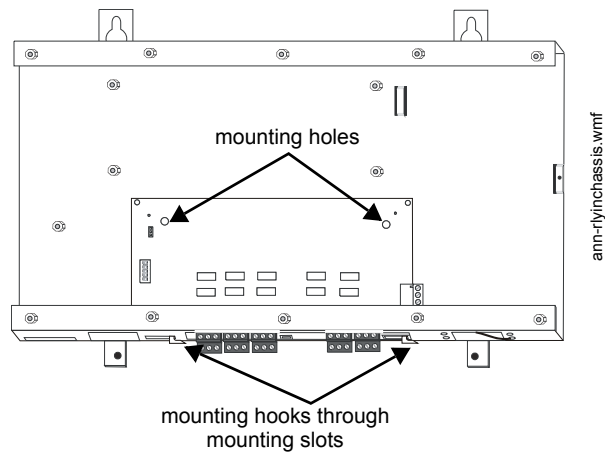

FACP Backbox Installation using ANN-MBRLY mounting bracket

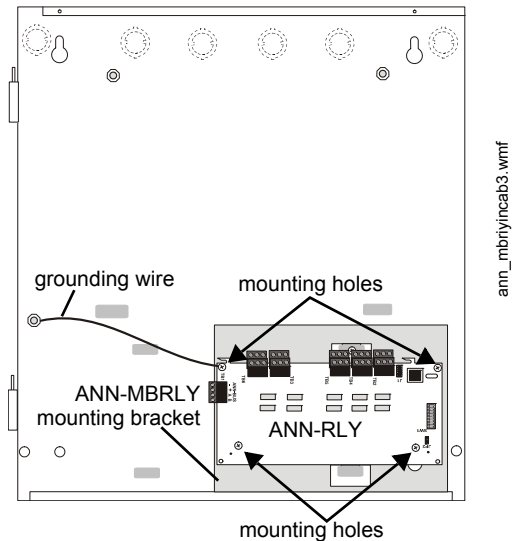

ROME Series Installation using ANN-MBRLY mounting bracket

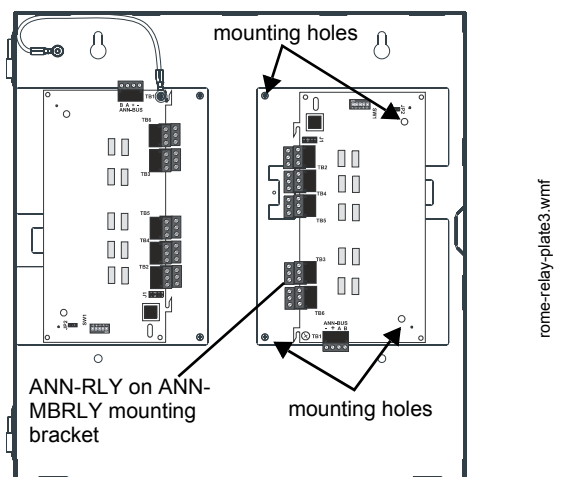

Figure 1.14 ANN-RLY Mounting Options

■ ANN-RLY Board Layout and Connection to FACP

Figure 1.15 illustrates the ANN-RLY board showing locations of screw terminals for connection to the FACP and the DIP switches for selecting the ANN-BUS ID number.

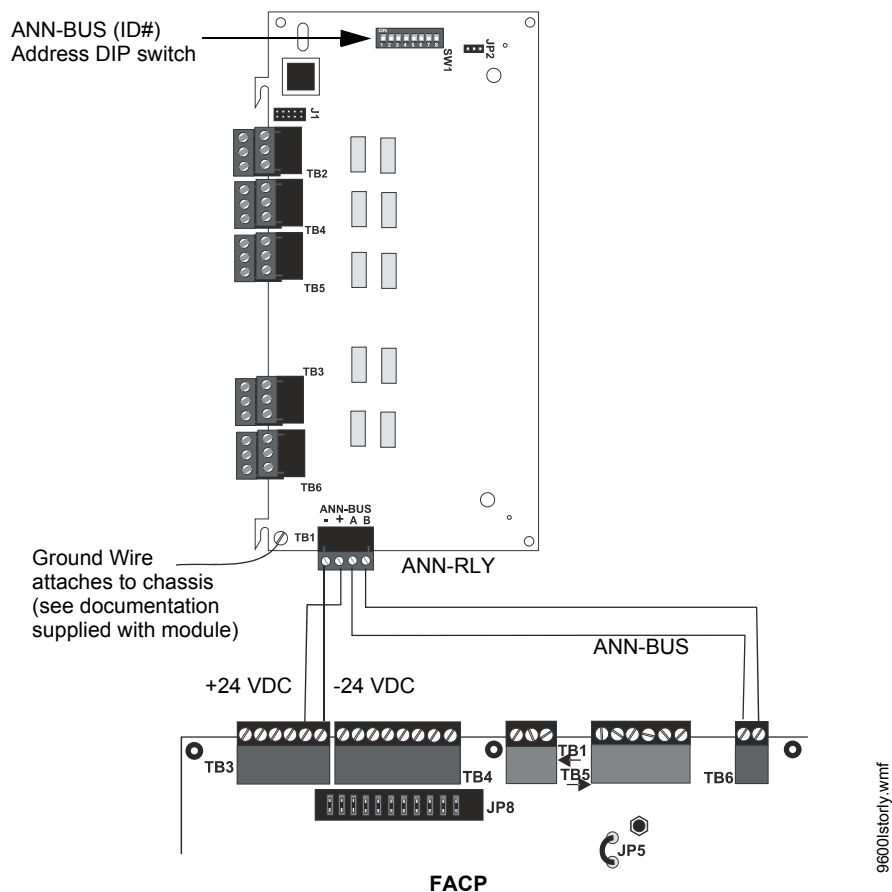

Figure 1.15 ANN-RLY Board Layout and Connection to FACP

ANN-BUS Audio Panel Control



WARNING: RISK OF ELECTRICAL SHOCK AND EQUIPMENT DAMAGE

DISCONNECT ALL SOURCES OF POWER (AC AND DC) BEFORE INSTALLING OR REMOVING ANY MODULES OR WIRING.

The FACP is capable of providing automated activation of the ACC-25/50(ZS/T) zoned system speaker circuits. To do this, the FACP must be enabled to communicate with the ACC-25/50ZS Audio Panel over the ANN-BUS (refer to “ANN-BUS Enabled” on page 121). This is accomplished by programming the Audio Panel ANN-BUS address into the FACP (refer to “Modules Installed” on page 121). For details on setting the ANN-BUS address and programming the audio panel, refer to the ACC-25/50ZS Series Audio Panel manual (document #51889).

The ACC-25/50ZS Series audio panel connects to the FACP via the ACS/ANN-BUS communication circuit. Zones 33 - 56 on the FACP correspond to the ACC-25/50ZS Series audio circuits 1 - 24. Zone 32 on the FACP serves as the All-Call zone and will activate all audio panel output circuits. The programmer can select which of the five audio messages at the audio panel will play when an FACP input zone goes into alarm (refer to “Zone Message” on page 149). The message will play over the corresponding audio panel output circuit.

Examples:

- FACP Input programmed to Zone 33 goes into alarm, the programmed message for Zone 33 [Message 1, 2, 3, 4 or 5] will play over the ACC-25/50ZS Series output circuit 1 which corresponds to FACP Zone 33.
- FACP Input programmed to Zone 1 and Zone 34 (Zone 1 is programmed for a Message [1, 2, 3, 4 or 5] and Zone 34 is programmed for No Message) goes into alarm, the programmed message for Zone 1 will play over the ACC-25/50ZS Series output circuit 2 which corresponds to FACP Zone 34.
- If two or more input zones are active at the same time, the highest priority message will turn on (Message 1 is highest priority and Message 5 is lowest) and play over the corresponding audio panel output circuit(s).
- Zone 32 is an All-Call zone. All audio panel output circuits will turn on if Zone 32 is activated and its programmed message will play (or the highest priority message currently being played).

A fault at the ACC-25/50ZS Series panel will cause the FACP to indicate a System Trouble and the display will indicate a Voice Evac Fault.

The only connection between the FACP and ACC-25/50ZS Series audio panel is a pair of communication wires connected between the A(+)/B(-) terminals on TB9 of the FACP and TB1 terminals 2 & 3 of the ACC-ZPMK module on the audio panel.

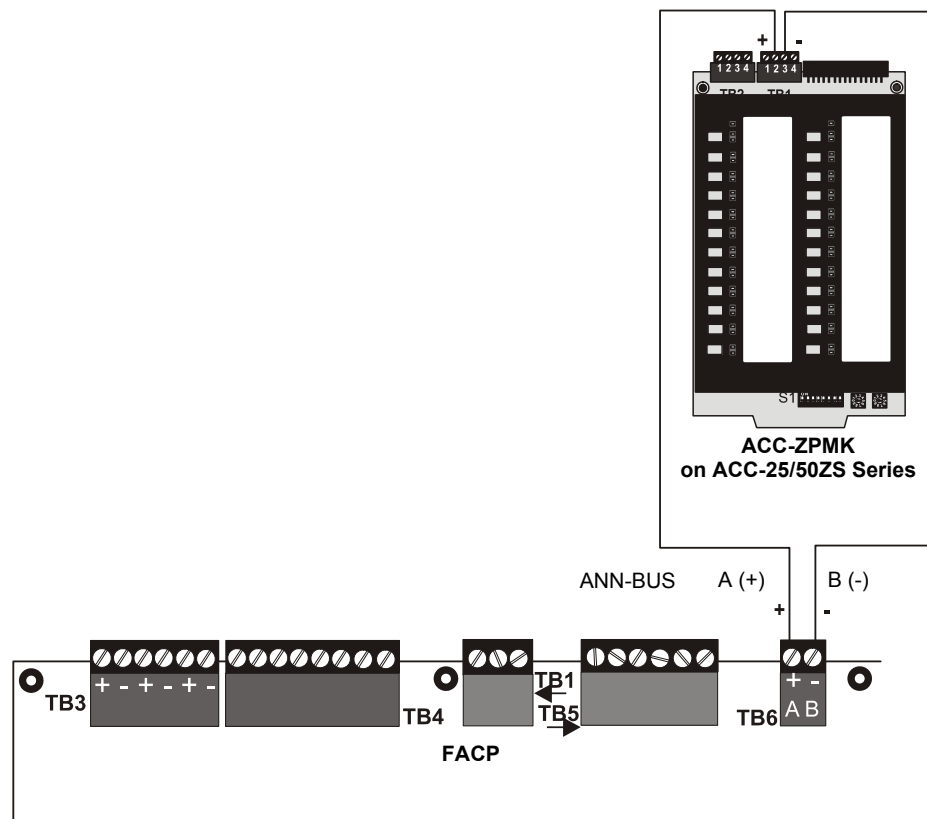

Figure 1.16 FACP Connection to ACC-25/50ZS Series Audio Panel

acczpmtonms9600uds.wmf

1.8.7 Legacy ACS Annunciators



WARNING: RISK OF ELECTRICAL SHOCK AND EQUIPMENT DAMAGE

DISCONNECT ALL SOURCES OF POWER (AC AND DC) BEFORE INSTALLING OR REMOVING ANY MODULES OR WIRING.

The legacy ACS annunciators may **not** be used if new ANN-BUS annunciators are being used due to incompatible serial communication protocols.

ACM Series LED Zone Type Annunciators

The ACM Series Annunciators remotely display alarm and trouble status as well as system status. For more detailed information, refer to the appropriate annunciator manual. Following is a list of annunciators which can be used with the FACP.

- **ACM-16ATF** - Annunciator Control Module annunciates 16 zones with 16 red alarm LEDs and 16 yellow trouble LEDs. In addition, it has a System Trouble LED, an On Line/Power LED and a local piezo sounder. *In Canada, this module must be used to annunciate the fire alarm input points/zones only.
- **AEM-16ATF** - Annunciator Expander Module annunciates 16 zones with 16 red alarm LEDs and 16 yellow trouble LEDs. *In Canada, this module must be used to annunciate the fire alarm input points/zones only.
- **ACM-32A** - Annunciator Control Module annunciates 32 alarm zones with 32 red LEDs. In addition, it has a System Trouble LED, an On Line/Power LED and a local piezo sounder. It also has a switch for local piezo silence. *In Canada, this module must be used to annunciate the fire alarm input points/zones only.
- **AEM-32AF** - Annunciator Expander Module annunciates 32 alarm zones with 32 red LEDs. *In Canada, this module must be used to annunciate the fire alarm input points/zones only.

LCD-80F Remote Fire Annunciator

The LCD-80F annunciator is an 80-character backlit LCD remote fire annunciator that is capable of displaying English language text. Tactile switches provide remote system Acknowledge, Silence, Drill and Reset functions. A keyswitch allows enabling/disabling of the tactile switches. Communications between the control panel and the annunciator is accomplished over a serial interface employing the EIA-485 communication standard. Up to 32 LCD-80F annunciators may be connected to the EIA-485 circuit. The annunciators may be powered from the host FACP or a remote UL listed filtered power supply such as the FCPS Series. For more detailed information, refer to the LCD-80F manual.

The LCD-80F is *not* for use in Canadian applications.

LCD-80FC Remote Fire Annunciator (for use in Canadian applications)

The LCD-80FC is identical to the LCD-80F except for the tactile switches and keyswitch. There is no keyswitch, and tactile switches are provided for local silence and lamp test only. No remote system functions can be performed from the LCD-80FC annunciator.

LDM Series Lamp Driver Modules (Graphic Annunciator)

The LDM Series Lamp Driver Modules, which consist of the LDM-32F master and LDM-E32F expander modules, are used to provide an interface to a custom graphic LED annunciator.

1.9 Getting Started

The following is a brief summary of the minimal steps involved in bringing an MS-9600LS/MS-9600UDLS on-line:

- Install Backbox, Power Supply and Main Circuit Board (refer to “Mounting” on page 42).
- Address and Install Intelligent Devices (refer to the SLC Wiring Manual).

- Enter Autoprogramming (refer to “Autoprogram” on page 66).
- Resolve Programming Conflicts.
- Go to Point Program to Enter Specific Data (refer to “Point Program” on page 67). Use the right and left arrow keys to navigate between devices.

Section 2: Installation

The cabinet may be either semi-flush or surface mounted. The cabinet mounts using key slots and two 0.250" (6.35 mm) diameter holes located in the backbox. The key slots are located at the top of the backbox and the two securing holes at the bottom.

Carefully unpack the system and check for shipping damage. Mount the cabinet in a clean, dry, vibration-free area where extreme temperatures are not encountered. The area should be readily accessible with sufficient room to easily install and maintain the panel. Locate the top of the cabinet approximately 5 feet (1.5 m) above the floor with the hinge mounting on the left. Determine the number of conductors required for the devices to be installed. Sufficient knockouts are provided for wiring convenience. Select the appropriate knockout(s) and pull the conductors into the box. All wiring should be in accordance with the National and/or Local codes for fire alarm systems.

2.1 Mounting

The circuit board contains static-sensitive components. Always ground yourself with a proper wrist strap before handling any boards so that static charges are removed from the body. Use static suppressive packaging to protect electronic assemblies.

- Mark and predrill holes in the wall for the center top keyhole mounting bolt using the dimensions illustrated in Figure 2.2 on page 44.
- Install center top fastener in the wall with the screw head protruding.
- Place backbox over the top screw, level, and secure.
- Mark and drill the left and right upper and lower mounting holes.
Note: outer holes (closest to sidewall) are used for 16" O.C. stud mounting.
- Install remaining fasteners and tighten.
- Attach solid earth ground wire to grounding stud as indicated in Figure 2.1.
- When the location is dry and free of construction dust, install the main circuit board chassis by positioning the two mounting tab holes on the top of the chassis over the mounting studs in the top of the backbox and sliding the mounting tabs at the bottom of the chassis into the mounting slots in the bottom of the backbox as illustrated below.
- Secure the chassis to the mounting studs with the supplied nuts.

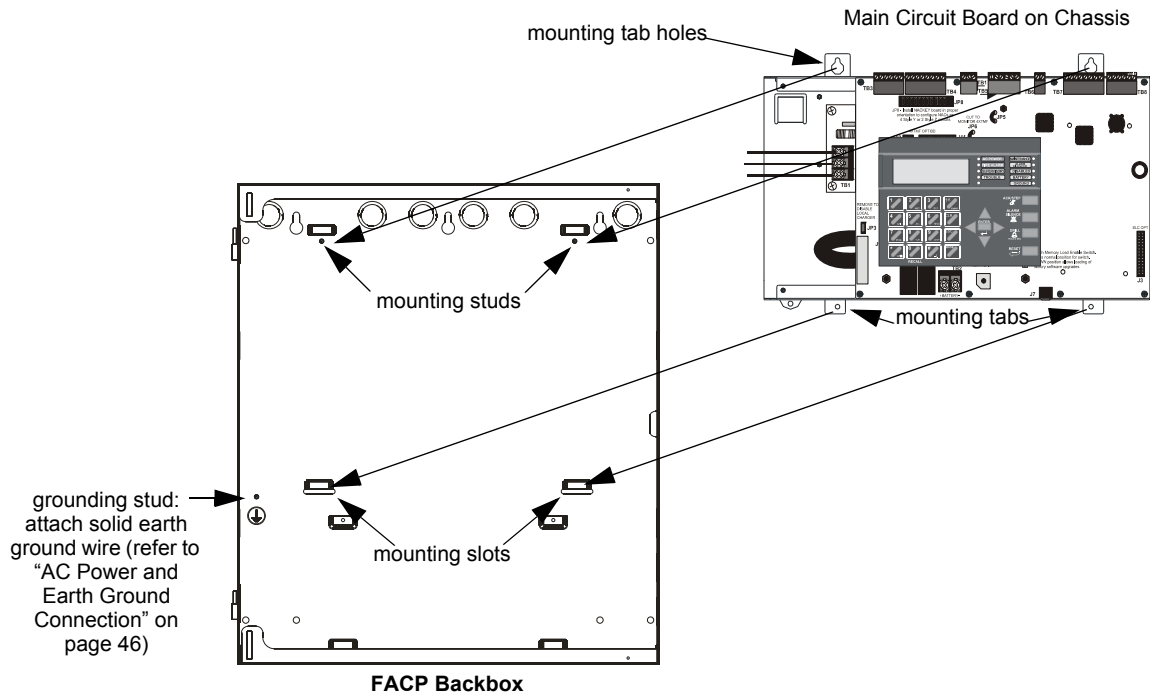

9600lsbrinbox.wmf

Figure 2.1 FACP Main Circuit Board Installation

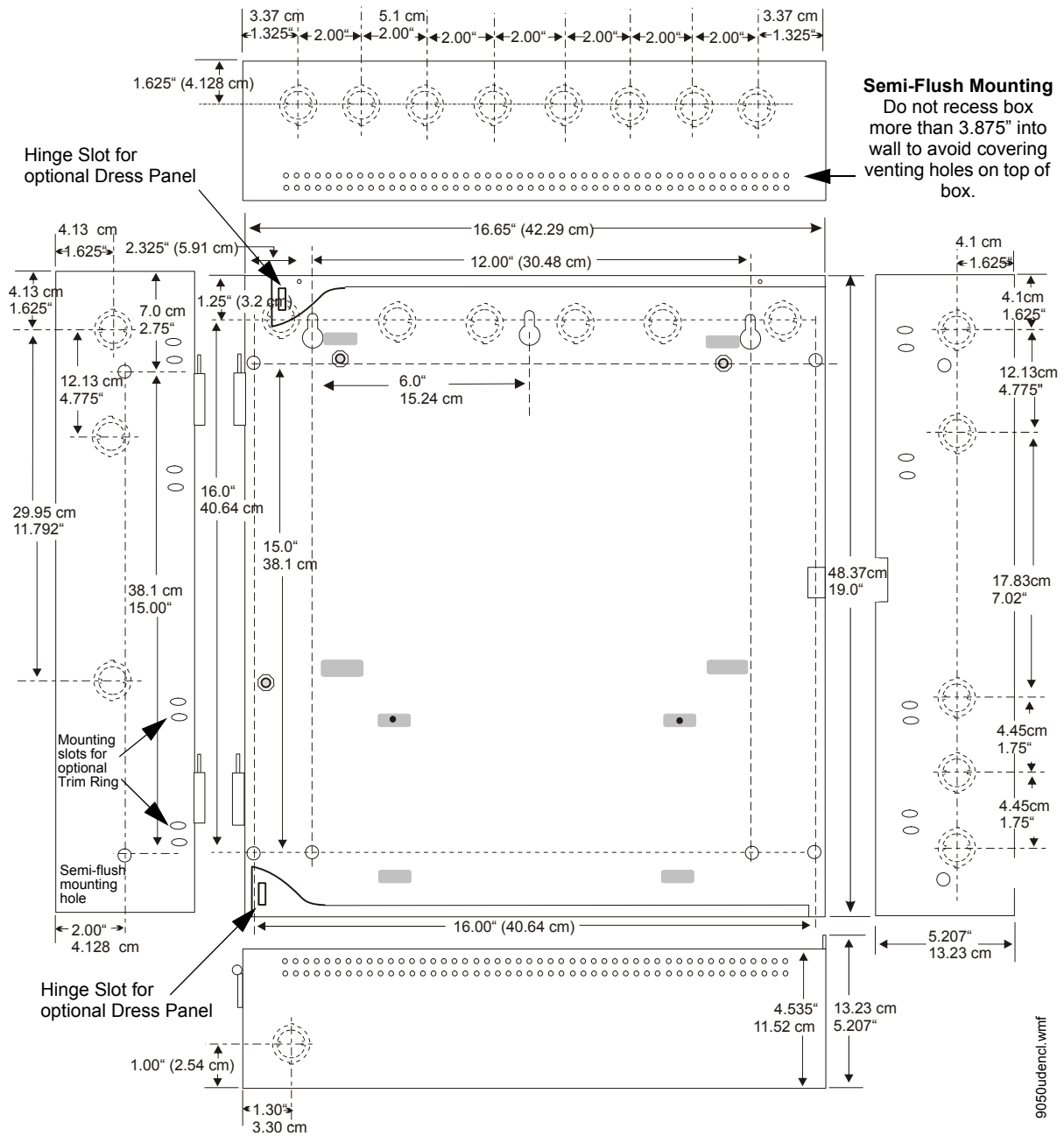

Figure 2.2 FACP Cabinet Mounting

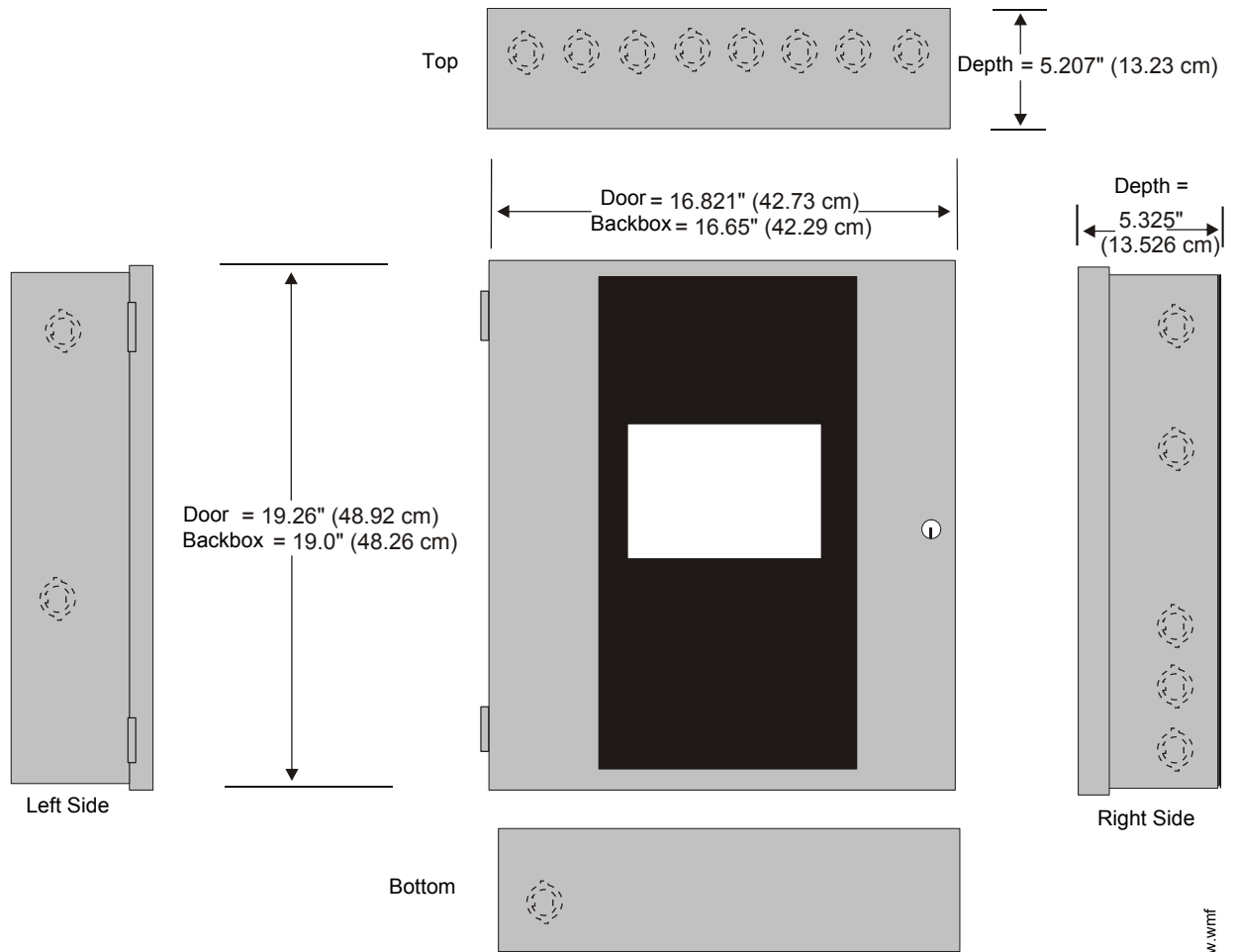

Figure 2.3 FACP Cabinet Dimensions

9600cabnew.wmf

2.2 Power



WARNING: RISK OF ELECTRICAL SHOCK AND EQUIPMENT DAMAGE

SEVERAL DIFFERENT SOURCES OF POWER CAN BE CONNECTED TO THIS PANEL. DISCONNECT ALL SOURCES OF POWER BEFORE SERVICING. THE PANEL AND ASSOCIATED EQUIPMENT MAY BE DAMAGED BY REMOVING AND/OR INSERTING CARDS, MODULES OR INTERCONNECTING CABLES WHILE THIS UNIT IS ENERGIZED.

2.2.1 AC Power and Earth Ground Connection

Primary power required for the FACP is 120 VAC, 60 Hz, 3.0 amps for the MS-9600LS(C) and MS-9600UDLS or 240 VAC, 50 Hz, 1.5 amps for the MS-9600LSE and MS-9600UDLSE. Overcurrent protection for this circuit must comply with Article 760 of the National Electrical Code (NEC) and/or local codes. Use 14 AWG (2.00 mm²) or larger wire with 600 volt insulation rating. Make certain that the AC mains circuit breaker is off before wiring any connections between the mains and the control panel. Connect wiring from the AC mains to TB1 on the FLPS-7 Power Supply, being careful to observe proper connections. Illustration depicts connection of 120 VAC to TB1. Note that the FLPS-7 Power Supply is connected to the main circuit board by a cable connected to J1. Ensure that this cable is connected.

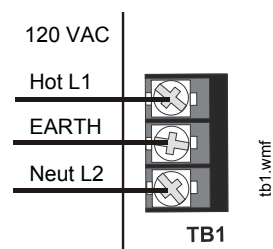

Connect a wire from the grounding stud in the cabinet to a known solid earth ground (refer to Figure 2.1 on page 43). This connection is vital for maintaining the control panel's immunity to unwanted transients generated by lightning and electrostatic discharge. Apply AC power to the panel only after the system is completely installed and visually checked. *Note that AC power must be applied to the panel before installing the battery interconnect cable (refer to the following section).*

2.2.2 Battery Power

Before connecting the batteries to the FACP, make certain that the interconnect cable between the batteries is not connected. Do not connect the interconnect cable until the system is completely installed. Observe polarity when connecting the batteries. Connect the battery cable to TB2 on the main circuit board. Refer "Power Supply Calculations" on page 174, for calculation of the correct battery rating.

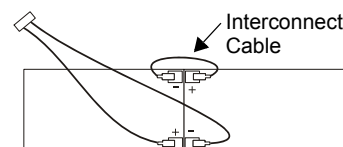

WARNING: RISK OF PERSONAL INJURY

BATTERY CONTAINS SULFURIC ACID WHICH CAN CAUSE SEVERE BURNS TO THE SKIN AND EYES AND CAN DESTROY FABRICS. IF CONTACT IS MADE WITH SULFURIC ACID, IMMEDIATELY FLUSH THE SKIN OR EYES WITH WATER FOR 15 MINUTES AND SEEK IMMEDIATE MEDICAL ATTENTION.

2.2.3 Special Application DC Power Output Connection

All Special Application DC power outputs are power-limited.

<p>Power-limited Resettable Power 1.5 amperes max., 24 VDC nominal filtered, resettable power can be drawn from TB3 Terminals 1(+) and 2(-)</p>	<p>Power-limited Nonresettable Power #1 1.5 amperes max., 24 VDC nominal filtered, nonresettable power can be drawn from TB3 Terminals 3(+) and 4(-)</p>	<p>Power-limited Nonresettable Power #2 1.5 amperes max., 24 VDC nominal filtered, nonresettable power can be drawn from TB3 Terminals 5(+) and 6(-)</p>
--	---	---

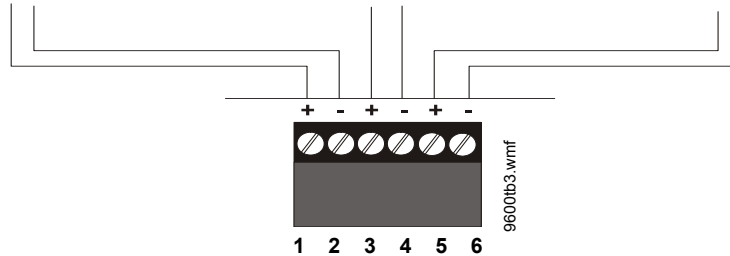

Figure 2.4 Special Application Power Outputs - 24 VDC

2.3 Relays

The FACP provides two programmable Form-C relays and one fixed fail-safe Form-C trouble relay, all with contacts rated for 2.0 amps @ 30 VDC (resistive) or 0.5 amps @ 30 VAC (resistive). The Alarm and Supervisory silk-screen labels reflect the factory default programming for the two programmable relays.

Note that relay connections must be power-limited. Refer to Power-limited wiring requirements.

Note that the relays labeled as Alarm Relay (Relay 1) and Supervisory Relay (Relay 3) reflect the factory default programming for these relays which are programmable. The relay labeled Trouble Relay (Relay 2) is fixed and cannot be changed. It is a fail-safe relay which will transfer on any trouble or total power failure.

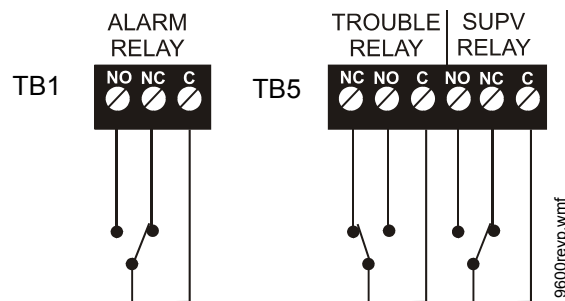

Relay contacts shown with power applied to panel and no active troubles, alarms or supervisories

Figure 2.5 Relay Terminals

2.4 Notification Appliance Circuits

The control panel provides four Style Y/Class B or two Style Z/Class A NACs (Notification Appliance Circuits). Each circuit is capable of 3.0 amps of current. Total system current in alarm cannot exceed 7.0 amps (refer to “Calculating the System Current Draw” on page 174). Use UL listed 24 VDC notification appliances only. Circuits are supervised and power-limited. Refer to the Device Compatibility Document for a listing of compatible notification appliances. The NACs, which are located on the main circuit board, may be expanded via the FCPS Series field charger/power supplies.

The following sections describe the configuration and wiring of Style Y and Style Z Notification Appliance Circuits on the FACP main circuit board. The NACs are configured for Style Y (Class B) from the factory. Refer to “Configuring NACs” on page 48 for information on changing the NAC configuration to Style Z (Class A) and preparing the NACKEY configuration card located in JP8, when installing a 4XTMF Transmitter Module.

2.4.1 Configuring NACs

The Notification Appliance Circuits on the main circuit board are configured for Style Y or Style Z by properly orienting the NACKEY card in JP8 which is located at the top of the main circuit board near the NAC Terminal TB4. The default configuration is for Style Y (Class B). Refer to Figure 2.6 for information on installing the NACKEY card.

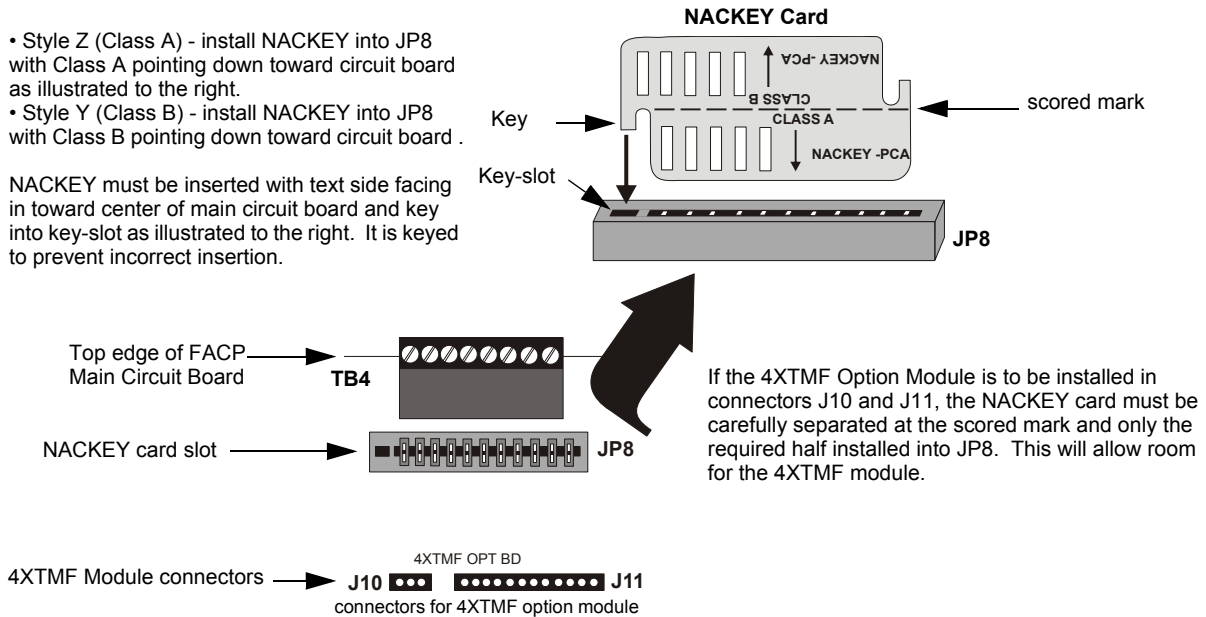
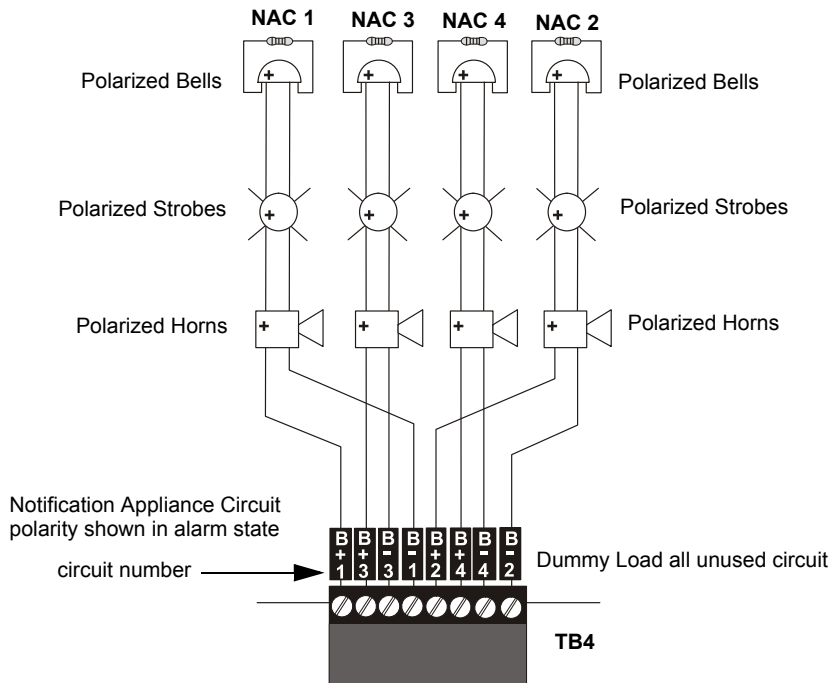

Figure 2.6 NAC Configuration Using NACKEY

2.4.2 Style Y (Class B) NAC Wiring

4 Style Y (Class B) Notification Appliance Circuits, supervised and power-limited - 4.7K ohm, 1/2 watt P/N:71252 UL-listed



9600nacy.wmf

Figure 2.7 NAC Style Y (Class B) Wiring

2.4.3 Style Z (Class A) NAC Wiring

2 Style Z (Class A) Notification Appliance Circuits, supervised and power-limited

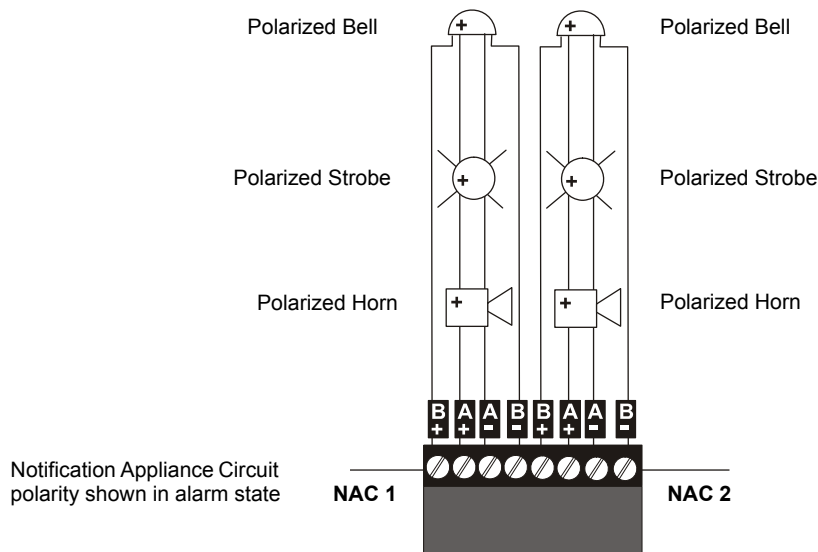

9600nac2.cdr

Figure 2.8 NAC Style Z (Class A) Wiring

2.5 Power-limited Wiring Requirements

Power-limited and nonpower-limited circuit wiring must remain separated in the cabinet. All power-limited circuit wiring must remain at least 0.25" (6.35 mm) away from any nonpower-limited circuit wiring and nonpower-limited circuit wiring must enter and exit the cabinet through different knockouts and/or conduits. A typical wiring diagram for the FACP is shown below.

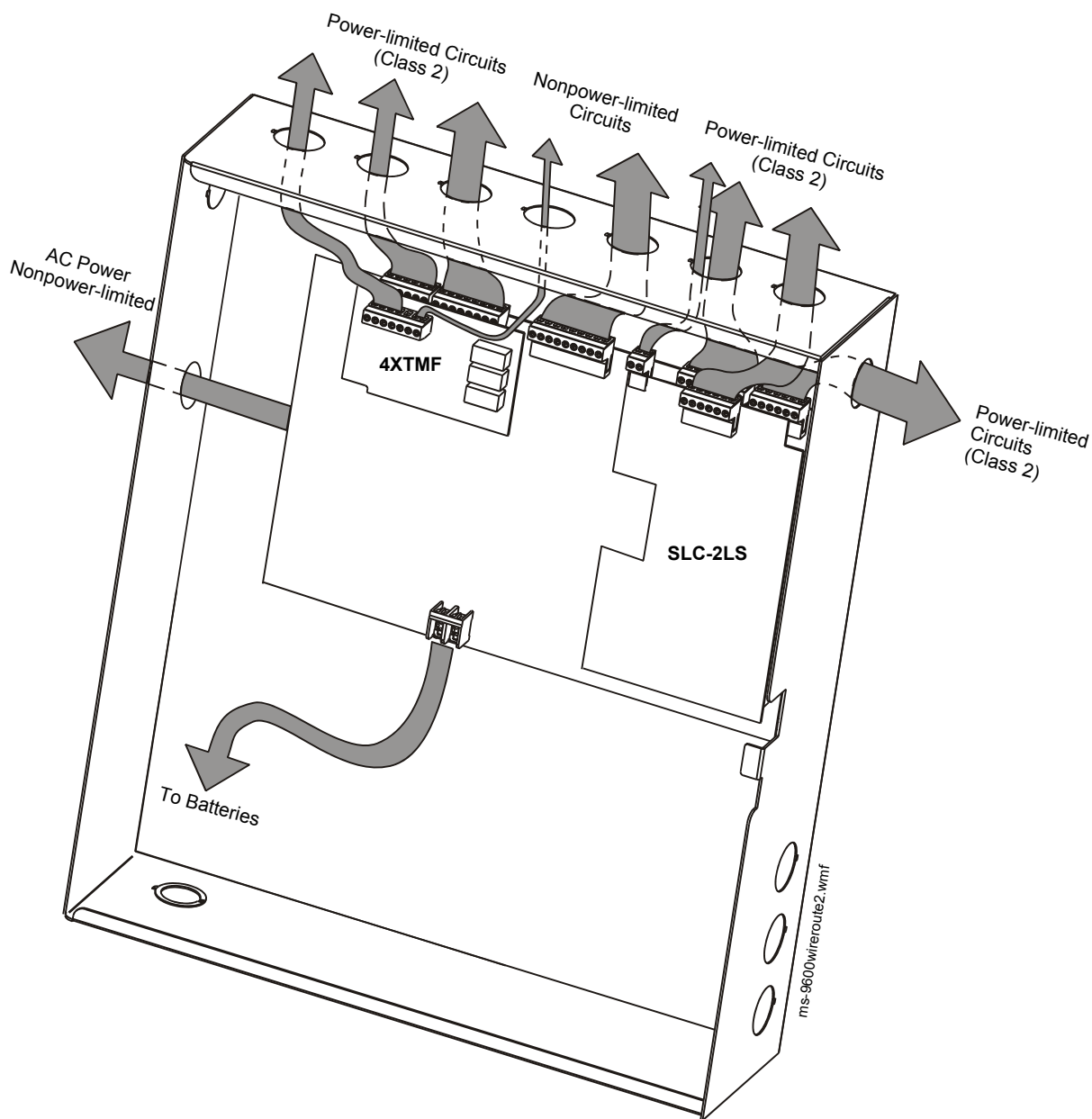

Figure 2.9 Typical Power-limited Wiring Requirements

2.6 Optional Modules and Devices



WARNING: RISK OF ELECTRICAL SHOCK AND EQUIPMENT DAMAGE

DISCONNECT ALL SOURCES OF POWER (AC AND DC) BEFORE INSTALLING OR REMOVING ANY MODULES OR WIRING.

FACP Keypad/Display Removal

Removal of the keypad/display is normally not necessary. If, however, it becomes necessary to replace the keypad/display, access the auxiliary trouble bus connectors at J16 and J17 or install the DACT-UD2 option module on J2, the Keypad/Display can be removed by inserting a Phillips screwdriver into each of the three holes located in the flexible covering of the Keypad/Display and loosening the three mounting screws. Note that it is not necessary to disconnect the cables between the Keypad/Display and the main circuit board unless the unit itself is being replaced. Carefully lift the Keypad/Display and rest the unit at the bottom of the main circuit board.



NOTE: When installing the DACT-UD2, the main motherboard must be removed from the chassis. Unplug the power supply cable from J1 before proceeding.

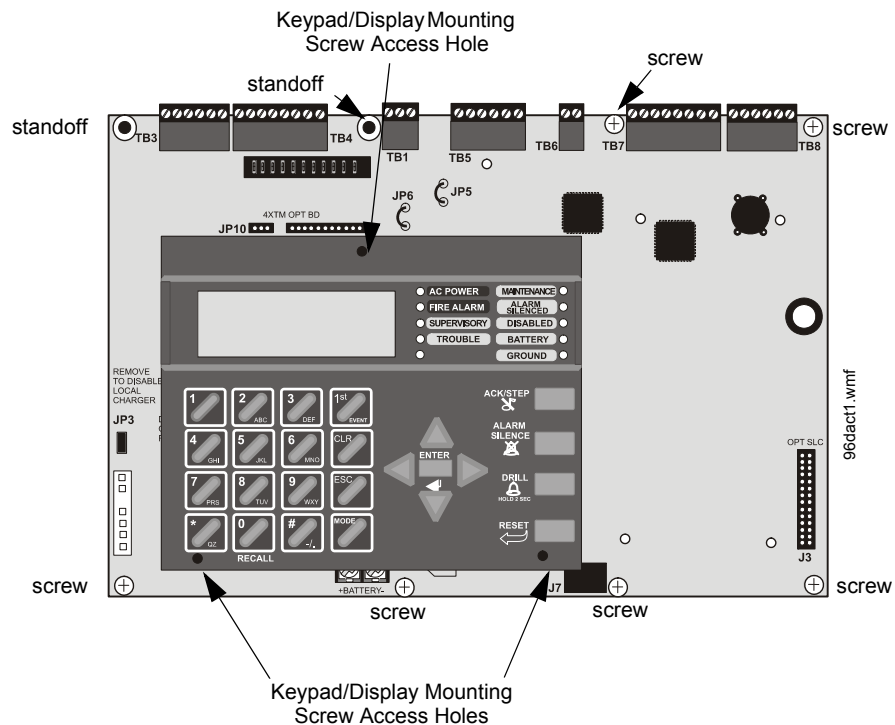

Figure 2.10 Keypad/Display Removal

2.6.1 DACT-UD2 Installation



WARNING: RISK OF ELECTRICAL SHOCK AND EQUIPMENT DAMAGE

DISCONNECT ALL SOURCES OF POWER (AC AND DC) BEFORE INSTALLING OR REMOVING ANY MODULES OR WIRING.

The DACT-UD2 Digital Alarm Communicator/Transmitter, which is supplied standard with the MS-9600UDLS/E, transmits system status to UL listed Central Station receivers via the public switched telephone network. It is capable of reporting up to 99 software zones or up to 636 addressable points. Two modular phone jacks, labeled PRI for Primary phone line and SEC for Secondary phone line, allow easy connection of two independent telephone lines to the DACT-UD2. The following functions have been incorporated into the DACT-UD2:

- Line Seizure - takes control of phone lines disconnecting any premises phones
- Off/On Hook - performs on and off-hook status to the phone lines
- Listen for dial tone - 440 hertz tone typical in most networks
- Dialing Central Station(s) number - default is Touch-Tone®, programmable to rotary
- For tone burst or touchtone type formats: determine proper 'Acknowledge' and 'Kissoff' tone(s) - the frequency and time duration of the tone(s) varies with the transmission format. The control panel will adjust accordingly
- Communicate in the following formats:
 - Ademco Contact ID
 - SIA

The DACT-UD2 module plugs into connector J2 on the FACP main circuit board.

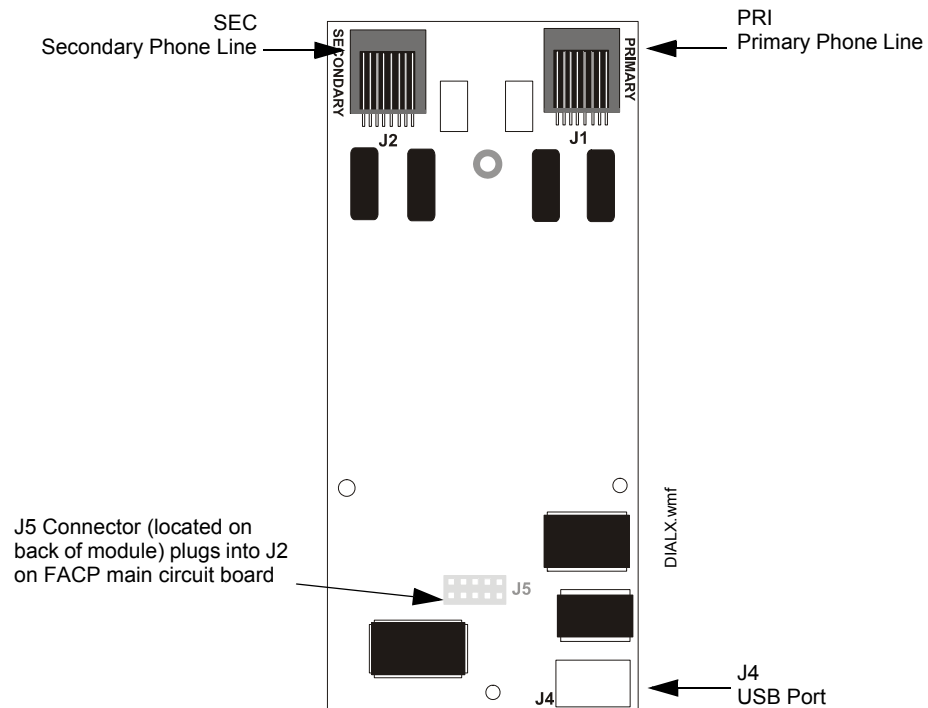

Figure 2.11 DACT-UD2 Module

The following steps must be followed when installing the DACT-UD2 module:

1. Remove all power (AC and DC) from FACP before proceeding with installation
2. Remove all main circuit board mounting screws (6 locations) and the 4XTMF module standoffs (2 locations), unplug the power supply cable from J1 and lift the main circuit board assembly off the chassis (refer to Figure 2.10)
3. Remove the Keypad/Display from the main circuit board as described in the beginning of this section
4. Remove and discard the Keypad/Display support standoff that presently occupies DACT-UD2 standoff location #3 (refer to Figure 2.12)
5. Install the supplied DACT-UD2 female/female standoffs in the three locations shown in Figure 2.12 and secure with the three supplied screws, inserted from the bottom side of the main circuit board. Be sure to tighten them fully.
6. Carefully plug connector J5 on back of the DACT-UD2 module into connector J2 on the FACP main circuit board, being careful not to bend any pins
7. Align the mounting holes in the DACT-UD2 module with the newly installed standoffs on the FACP main circuit board

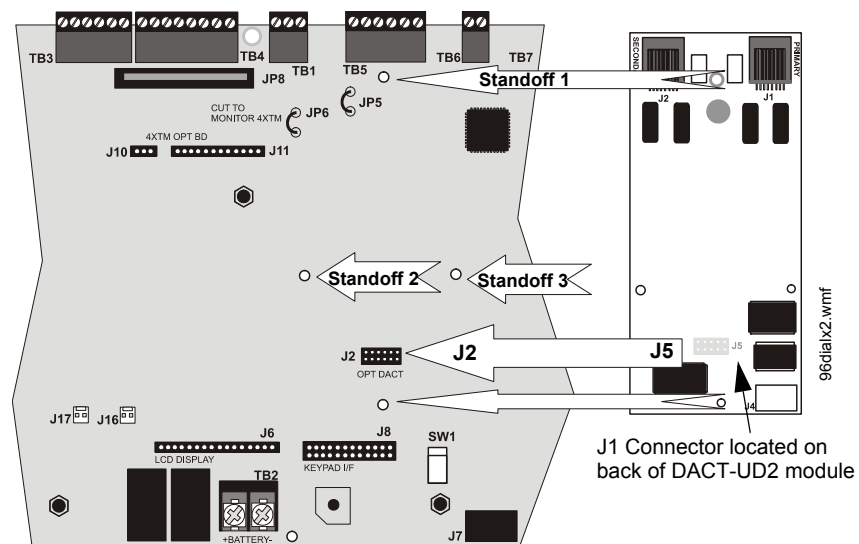

Figure 2.12 DACT-UD2 J1 Connector to FACP J2 Connector

Secure the module to the standoffs on the main circuit board with two of the screws supplied with the DACT-UD2 and the supplied male/female standoff which replaces the screw Keypad/Display support in that location (see Figure 2.11).



NOTE: It is important that the supplied hardware be used to secure the module in order to help protect against electrical transients.

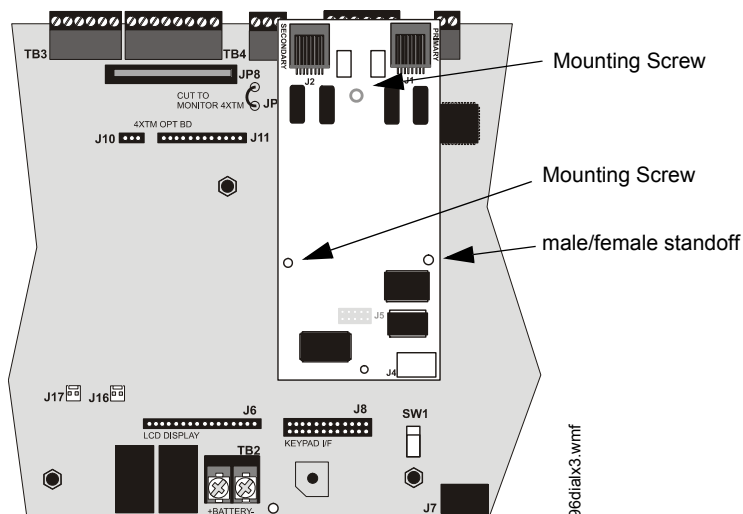

Figure 2.13 DACT-UD2 Installation on Standoffs

8. Reinstall Keypad/Display on the main circuit board by positioning the unit over the appropriate standoffs and securing with screws which were loosened in step 3
9. Remount the main circuit board assembly to the chassis using screws and standoffs in their original locations. Plug in the power supply cable at J1 on the main circuit board
10. Make certain to program the control panel for DACT-UD2 operation
11. Refer to the Telephone Requirement and Warnings section of the DACT-UD2 Installation and Programming Manual Document #53037, before proceeding with this step. Connect the premises primary and secondary phone lines to the DACT-UD2 as illustrated in Figure 2.14 and test the system for correct operation

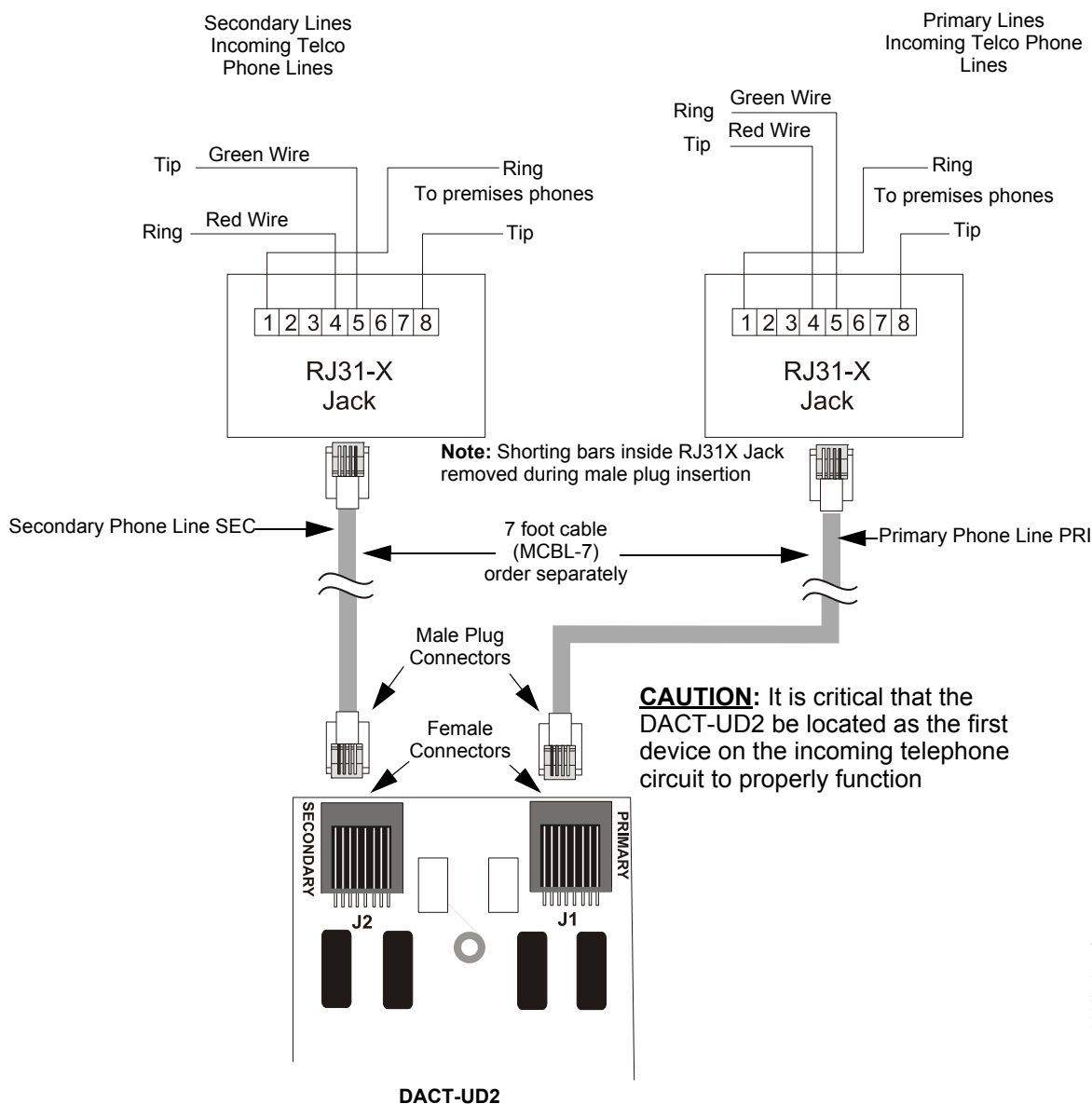

Figure 2.14 Wiring Phone Jacks

2.6.2 4XTMF Transmitter Module Installation

The 4XTMF provides a supervised output for a local energy municipal box transmitter in addition to alarm and trouble reverse polarity. A jumper option allows the reverse polarity circuit to open with a system trouble condition if no alarm condition exists. A disable switch allows disabling of the transmitter output during testing to prevent accidental calling of the monitoring service.

Local Energy Municipal Box Service (NFPA 72 Auxiliary Fire Alarm Systems):

Supervisory Current: 5.0 mA

Trip Current: 350 mA (subtracted from notification appliance power)

Coil Voltage: 3.65 VDC

Maximum Coil Resistance: 14.6 ohms

Maximum allowable wire resistance between panel and trip coil: 3 ohms

Municipal Box wiring can leave the building

Remote Station Service (NFPA 72 Remote Station Fire Alarm Systems) - Intended for connection to a polarity reversal circuit or a Remote Station receiving unit having compatible ratings:

Maximum load for each circuit: 10 mA

Reverse polarity output voltage: 24 VDC

Remote Alarm and Remote Trouble wiring can leave the building

Before installing the module, place the disconnect switch to the right (disconnect) position to prevent accidental activation of the municipal box. Note that a Disconnect LED will illuminate after the module is installed in the FACP. In addition, the System Trouble LED will turn on to indicate the Disconnect condition.

Note: 4XTMF Module is not suitable for transmitting reverse polarity supervisory signal.

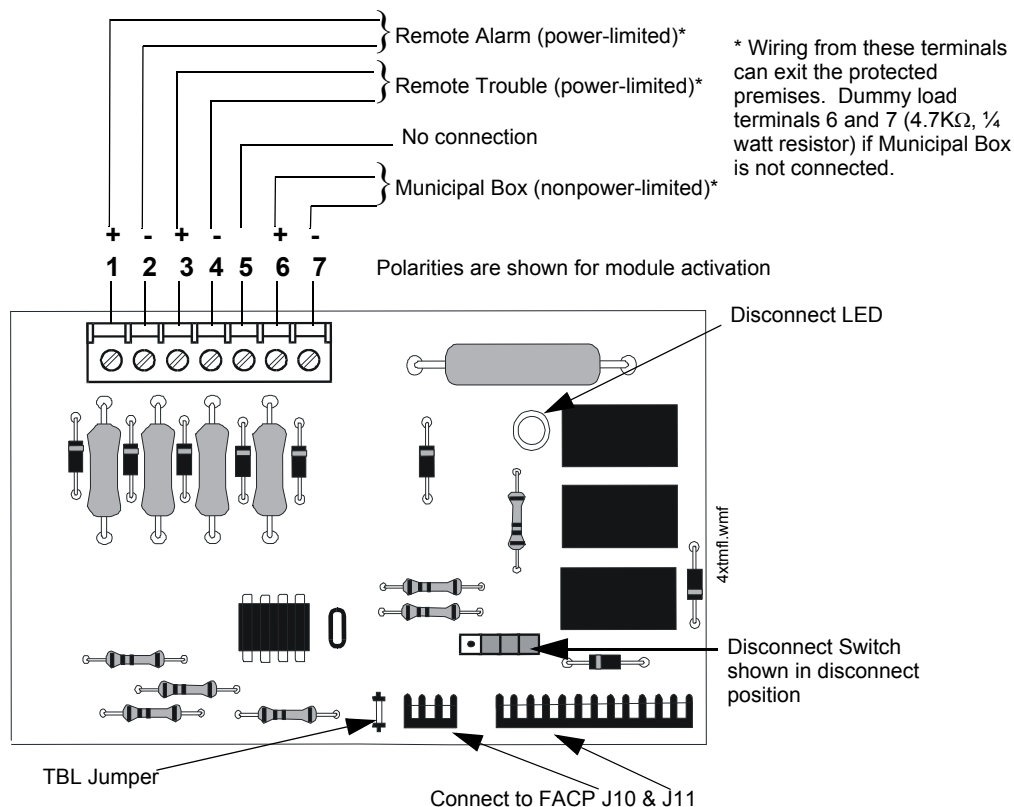

Figure 2.15 4XTMF Transmitter Module

The following steps must be followed when installing the 4XTMF module:

1. Remove all power (AC and DC) from the FACP before installing 4XTMF
2. Cut jumper JP6 on the main circuit board to allow the control panel to supervise the 4XTMF module
3. The NACKEY Card must be separated at the score mark to allow connection of the 4XTMF module (refer to Figure 2.6 on page 48 for complete information)
4. Carefully plug the connectors on the 4XTMF module into connectors J10 and J11 on the FACP main circuit board, being careful not to bend any pins
5. Secure 4XTMF module to standoffs with supplied screws.
6. Reapply power to the FACP
7. For proper 4XTMF operation, the output relays must be programmed for the factory default settings as shown on the PC board silkscreen: Alarm Relay, Trouble Relay and Supervisory Relay

8. When the installation has been complete, enable the 4XTMF module by sliding the disconnect switch to the left
9. Test system for proper operation

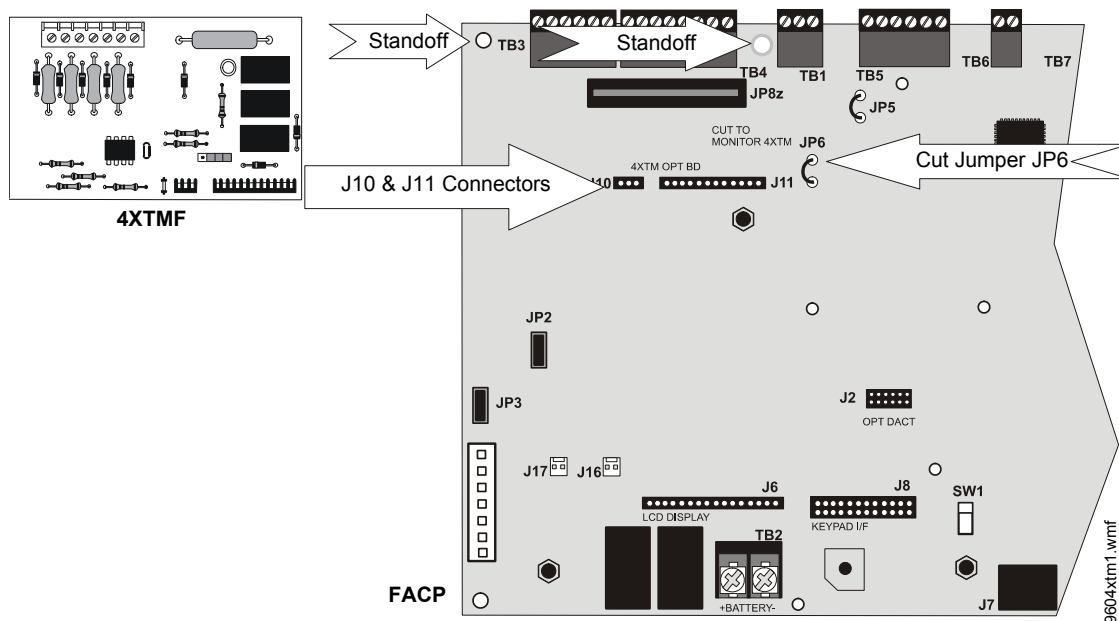

Figure 2.16 4XTMF Connectors to FACP Connectors



NOTE: Jumper JP5 on the FACP main circuit board can be used to configure the FACP supervisory relay for operation with the 4XTMF module. The supervisory relay must be programmed as shown on the main circuit board silk-screen (TB5, Terminals 4, 5 & 6). Cutting JP5 will allow the 4XTMF to generate a trouble if the supervisory contact opens. Leaving JP5 in will prevent generation of a trouble if the supervisory contact opens.

2.6.3 Auxiliary Trouble Input (J16 & J17)

Auxiliary Trouble Inputs 1 (J17) and 2 (J16), which are located on the FACP main circuit board, can be used to monitor for trouble conditions on auxiliary equipment such as power supplies. J16 and/or J17 can be connected to any open collector trouble output on the auxiliary equipment. The control panel will indicate a trouble condition if a trouble is sensed at the Auxiliary Trouble Inputs.

If the 4XTMF Module is installed and FACP jumper JP6 has been cut to supervise it, Auxiliary Trouble Input 1 (J17) will monitor the 4XTMF for trouble conditions.

2.6.4 SLC-2LS Expander Module

The optional SLC-2LS Expander Module provides a second SLC loop for the FACP control panel. This allows connection of an additional 318 addressable devices, bringing the total to 636 addressable devices which can be connected to the FACP. Refer to the SLC Wiring Manual for information on connecting devices to the SLC.

IMPORTANT! When SLC wiring is run in conduit, each SLC loop must be installed in separate conduit.

The following steps must be followed when installing the SLC-2LS Expander Module:

1. Remove all power (AC and DC) from the FACP before installing the SLC-2LS module
2. Remove four screws from main FACP motherboard, from locations indicated in following illustration, and replace with four supplied metal standoffs

3. Carefully plug connector J3 on the SLC-2LS module into connector J3 on the MS-9600LS/MS-9600UDLS main circuit board, being careful not to bend any pins
4. Secure the SLC-2LS Expander Module to the four standoffs installed in step 2 with the four supplied screws (or the screws removed in step 2)
5. Connect the SLC wiring and devices to TB8 on the SLC Expander Module. Refer to the SLC Wiring Manual for wiring information
6. Reapply power to the control panel
7. Program the addressable devices connected to the SLC-2LS Expander Module as detailed in “Master Programming Level” on page 65
8. Test the system for proper operation

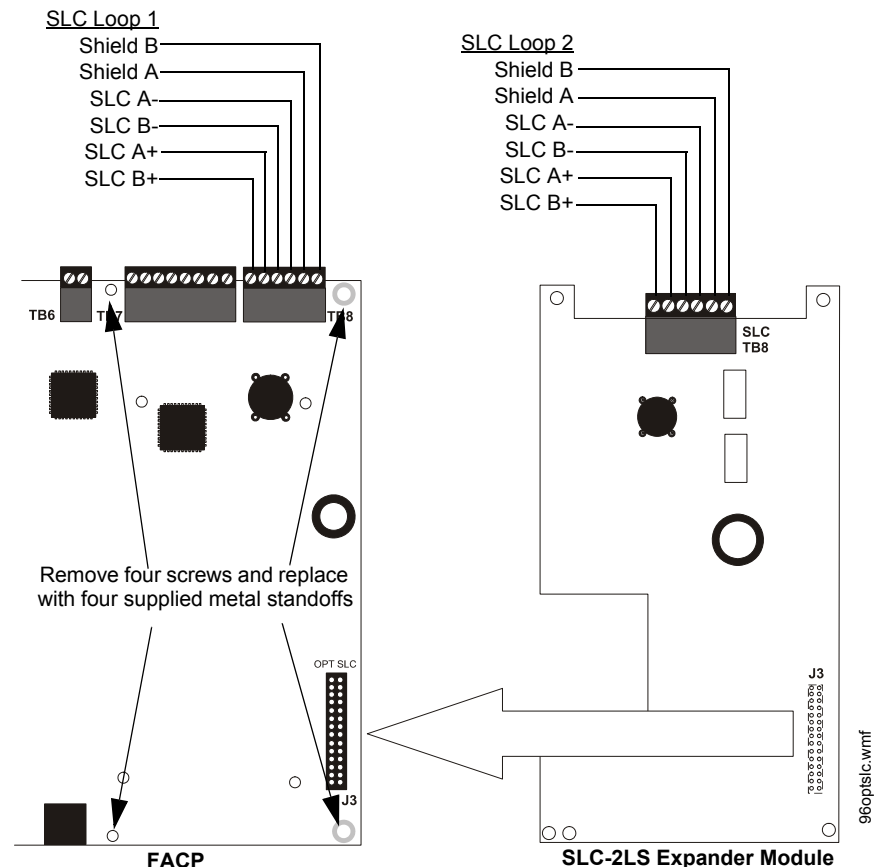

Figure 2.17 SLC-2LS Expander Module Installation

2.6.5 Printer/PC

A serial printer or a PC (personal computer) may be connected to TB7 Terminals 1 - 4 on the FACP. The printer can be used to provide a hard-copy printout of real-time events, history file and walktest data. An IBM compatible PC can be connected to provide local FACP programming capabilities using the PS-Tools programming utility. Installation of either device requires panel programming to allow the FACP to communicate with the device.

A parallel printer may also be connected to the FACP using the optional ANN-S/PG Serial/Parallel Interface Module. Refer to “ANN-S/PG Serial/Parallel Interface Installation” on page 30 for

installation details. Refer to “ANN-BUS Options” on page 121 for programming information.



CAUTION: POSSIBLE EQUIPMENT DAMAGE

DO NOT CONNECT A PRINTER OR PC TO THE FACP IF A GROUND FAULT (ZERO IMPEDANCE TO GROUND) EXISTS ON THE CONTROL PANEL. CIRCUIT DAMAGE MAY RESULT. REMOVE ALL POWER (AC AND DC) BEFORE INSTALLING OR REMOVING ANY WIRING.

Installation

Remote printers and PCs require separate primary power. Also required is the PRT/PK-CABLE which is an interface cable prewired to a DB9F connector. Wire the PRT/PK-CABLE to TB7 Terminals 1 - 4 as illustrated in the following figure. Connect the DB9F connector to the printer or PC serial EIA-232 port. If a nine-pin serial connector is not available on the printer or PC, use a DB25 adapter. *Make certain that the DB25 adapter does not swap the Transmit and Receive lines.* Apply power to the FACP and printer or PC. *Note that a ground fault (zero impedance to ground) may occur on the FACP, dependent on the printer or PC being used, due to this connection.* For this reason, it is important that there be no preexisting ground fault on the panel.

Note that the printer may or may not be supervised as determined by user programming. Refer to “Printer/PC” on page 134.

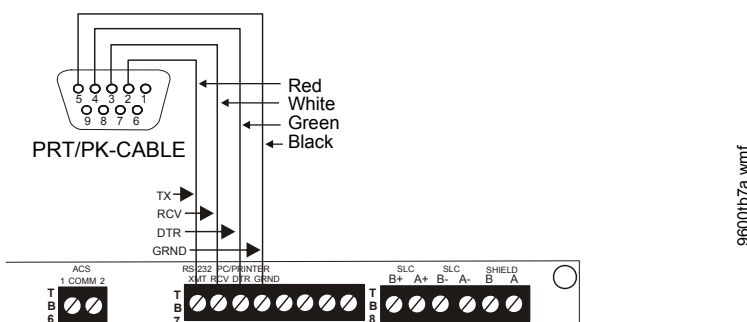

Figure 2.18 Serial Printer and Computer Connections

Printer Configuration

Refer to the documentation supplied with the printer for pertinent information about printer setup. Set the printer’s options as listed in the following table:

COMMUNICATION SETUP	
BUFFER:	LARGE
DATA BITS:	7
PARITY:	EVEN
STOP BIT:	1 STOP
BAUD RATE:	2400/4800/9600
AUTOMATIC LINE FEED	NO
AUTOMATIC CARRIAGE RETURN	NO

PC Configuration

The Windows-based PK-CD Programming Utility Kit contains a CD-ROM with on-line help file.

2.6.6 Annunciators

Legacy ACM-8RF Relay Control Module

The ACM-8RF module provides eight Form-C relays with contacts rated for 5 amps.

Legacy ACM Series Annunciators

ACM and AFM Series Annunciators provide visual indications of FACP status in remote locations. Refer to the appropriate annunciator manual for information on installation, wiring and operation.

Section 3: Programming

3.1 Programming Data Entry

Programming can be accomplished using the FACP keypad or by connecting an optional standard computer keyboard. The keyboard can be connected to the PS-2 connector J7 on the control panel main circuit board.

Local or remote programming and editing can also be accomplished using the DACT-UD2 Digital Alarm Communicator/Transmitter which is optional for the MS-9600LS and supplied standard with the MS-9600UDLS. Refer to the *DACT-UD2 Manual* P/N 53037 for detailed information.

The information presented in this section refers to programming the FACP via the onboard keypad. If an optional computer keyboard is connected to the FACP main circuit board, the following table describes the keyboard keys which correspond to the onboard keypad keys.

Keypad Keys	Computer Keyboard Keys
1st Event	Home
CLR	Delete
ESC	Esc
RECALL	Insert
*	*
#	#
A - Z	A - Z
0 - 9	0 - 9
■ (on QZ key)	Space bar
—	—
/	/
•	•
←	←
→	→
↑	↑
↓	↓
ENTER	Enter
ACK/STEP	F1
SILENCE	F2
DRILL	F3
RESET	F4

3.2 User Programming

The FACP is completely field programmable and requires no special software skills. *While programming the FACP, the fire protection capabilities of the control panel are enabled. Programming mode will time-out following 10 minutes of inactivity.*

Site-specific programming may be accomplished in three ways:

- **Autoprogramming Feature** - This is a convenient method for quickly bringing the FACP addressable SLC devices on-line without the necessity of programming each device individually. Refer to “Autoprogram” on page 66 for a detailed description of Autoprogramming
- Manual programming or editing, using the FACP keypad or a PC keyboard
- Remote Programming and Editing Feature - allows creation and editing of site-specific custom programs using a Windows-based computer and modem. For programs requiring a large amount of data entry, this method may be preferred. A PK-CD programming CD-ROM can be ordered for this purpose
- Local Programming and Editing Feature - allows creation and editing of site-specific custom programs using a Windows-based computer and the DACT-UD2 USB connection on the MS-9600UDLS or Serial Port connection on TB7 of the MS-9600LS. For programs requiring a large amount of data entry, this method may be preferred. A PK-CD programming CD-ROM can be ordered for this purpose

The *System All Normal* screen will be displayed in a programmed system with no active alarms, troubles or supervisories, as illustrated below:



Read Status mode can be entered while the panel is in any mode of operation. If an alarm or supervisory event exists at the panel, the event must be cleared before entering Programming mode. To access any of the programming or read status features, the *Enter* or *Mode* key must be pressed, which will cause the LCD to display the following:

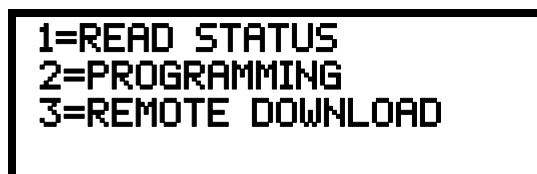

Pressing *1*, while this screen is being displayed, will cause the control panel to enter the Read Status feature which allows the user to view the programmed features and status of the control panel. The Read Status feature is not password protected. Refer to “Read Status” on page 160 for a detailed description of this feature.

Pressing *2* will select user Programming which may only be accomplished by an authorized person. After pressing *2*, a screen will prompt for a password. After entering the correct password, the user may select from a list of programming options.

Pressing *3* will select Remote Download which allows the user to enable the remote programming option. Refer to the DACT-UD2 manual P/N 53037.

Exit Programming or Read Status

The programmer can exit Read Status or Programming mode by repeatedly pressing the keypad *ESC* (Escape) key until the display reads System All Normal. Ten minutes of inactivity will also cause the FACP to exit Programming mode. *Note that the data which is entered during Programming mode is not saved until the programmer exits this mode by repeatedly pressing the 'ESC' key. If the Reset key is pressed or power is lost before exiting Programming mode, all data which was just entered will be lost.*

User Programming Levels

There are two user programming levels:

- User Master Program Level 1 is used for programming panel specific data relating to device types, zoning, messages, control panel functions, etc.
- User Maintenance Program Level 2 is used by a qualified operator to access features such as Disable/Enable, View and Clear History, Walktest and System Time Change.

3.3 Initial Power-up

The following sections describe the initial programming procedures for a new system. The same procedures are used to modify programming in an existing system.

After completing the wiring of addressable devices to the SLC, apply power to the control panel. If the addressable devices have not yet been programmed into the FACP, their LEDs will not flash and the following trouble message will be displayed.

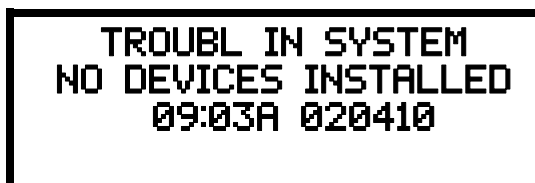

3.4 Programming Screens Description

The main options available when the *Enter* key is pressed are: Read Status, Programming Mode. Each option has multiple functions or features which may be chosen. To view all of the choices, it is necessary that the programmer scroll through a number of additional *subscreens*. These selections are displayed on multiple screens to make them more readable for the programmer. Refer to “Master Programming Level” on page 65, for additional information on the various screens.

The title of the main option screen will always be displayed at the top of the subscreens for the programmer’s convenience. If additional subscreens exist, an Up or Down arrow will be displayed in the upper right corner of the screen being viewed. The programmer can then press the keypad Up or Down arrow key to view the new subscreen. To select one of the choices in a screen, the programmer presses the keypad numerical key corresponding to the desired choice.

Note that subscreens may also have multiple options which require viewing more than one screen. The same process, as detailed in the previous paragraphs, is followed to view all option choices.

3.5 Programming and Passwords

There are two factory set programming passwords which will access the Programming screens as indicated in the following examples. From either of the screens, access to specific system and device features or programming may be obtained. All user programming entries are stored in non-volatile memory. The factory set passwords can be changed by the user as described in “Password

Change” on page 135. If an invalid password is entered, the blinking cursor will return to the first password character position. To exit Programming or Read Status mode at any time, press the *ESC* (Escape) key repeatedly. Note that Programming mode must be exited using the *ESC* key in order to store the program data entered during this mode. If the *Reset* key is pressed or power is lost before exiting Programming mode, the data just entered will not be saved.

To access user Programming mode, press the *Enter* or *Mode* key. The LCD will display the following:

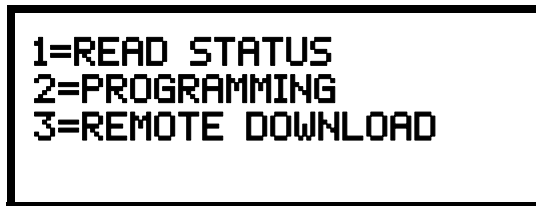

```
1=READ STATUS
2=PROGRAMMING
3=REMOTE DOWNLOAD
```

To enter the user Programming mode, press 2. The display will read as follows:



```
PROGRAMMING
ENTER PASSWORD
*****
```

Entering the ***Master*** level password (default 00000) will cause the following screen to appear:



```
PROGRAMMING
1=AUTOPROGRAM
2=POINT PROGRAM
3=ZONE SETUP
```

If the ***Maintenance*** level password (default 11111) is entered, the following screen will appear:



```
PROGRAMMING
1=POINT PROGRAM
2=HISTORY
3=PROGRAM CHECK
```

Note that in the two preceding screens, an arrow appears to inform the programmer that additional options can be viewed by pressing the keypad *down* arrow key.

3.6 Master Programming Level

When the Master Program Level password is entered, the control panel will enter user Programming mode. In this mode, the piezo sounder remains off, the trouble relay is activated and the system Trouble LED flashes until Programming mode is exited. The following display will appear:



Programming Screen #1

The down arrow which appears in the display indicates that additional programming choices can be viewed by pressing the down arrow key on the keypad. If a down and up arrow appear in the display, pressing the 'down' arrow key will display the subsequent Programming Screens as illustrated below while pressing the 'up' arrow key will display the previous screen.



Programming Screen #2



Programming Screen #3

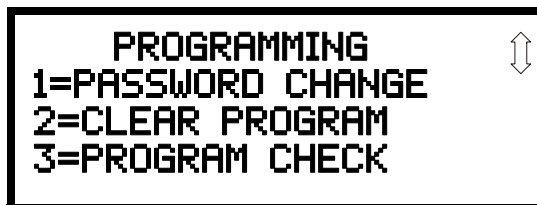

Programming Screen #4

3.6.1 Autoprogram

PROGRAMMING
1=AUTOPROGRAM
2=POINT PROGRAM
3=ZONE SETUP

Programming Screen #1

Pressing *I* while viewing Programming Screen #1, will select the Autoprogram option, which prompts the control panel to poll all devices installed on one or both SLC loops. The primary purpose of autoprogramming is to allow the installer a fast and easy way to bring the system on-line as quickly as possible. The first time the system is powered-up, it should be autoprogrammed.

If the system is already programmed and Autoprogram is initiated, the system will only add default values for newly installed devices.

When Autoprogram is selected, the programmer is given the option of autoprogramming all loops, only loop 1 or only loop 2. The following will be displayed on the LCD:

```
AUTOPROGRAM
1=LOOP 1
2=LOOP 2
3=ALL LOOPS
```

Autoprogram Loop Select Screen

After selecting one of the Autoprogram options, the control panel will begin autoprogramming the system by communicating with each addressable device installed on one or both loops. While autoprogramming, the panel will display the following:

```
AUTOPROGRAM
AUTOPROGRAMMING!
PLEASE WAIT
```

Autoprogram Progress Screen

When Autoprogramming is completed, the control panel will display the type and quantity of each device installed on the SLC loop(s) similar to the following display:

```
# OF DET LOOP1 055
# OF MON LOOP1 035
# OF CON LOOP1 030
```

Autoprogram Result Screen #1

```
# OF DET LOOP2 000
# OF MON LOOP2 000
# OF CON LOOP2 000
```

Autoprogram Result Screen #2

In the preceding example, the first display indicates that Loop 1 has 55 addressable detectors, 35 monitor modules and 30 control modules installed. The second display indicates that Loop 2 has no devices installed.

3.6.2 Point Program

PROGRAMMING
1=AUTOPROGRAM
2=POINT PROGRAM
3=ZONE SETUP

Programming Screen #1

The Point Program option allows the programmer to add a new addressable device to an SLC loop, delete an existing device from a loop or change the programming for an existing device. Pressing 2, while viewing Programming Screen #1, will select the Point Program option and display the following screen:

```

POINT PROGRAM
  SELECT LOOP
1=LOOP 1
2=LOOP 2
  
```

Point Program Screen #1

The programmer selects the desired SLC loop by pressing 1 or 2 in Point Program Screen #1, which causes the panel to display the following screen:

```

POINT PROGRAM
  SELECT TYPE
1=DETECTOR
2=MODULE
  
```

Point Program Screen #2

Detector Programming

Pressing 1, while viewing Point Program Screen #2, will allow the programmer to add, delete or change the programming of an addressable detector. The following screen will be displayed by the control panel:

```

DETECTOR
1=ADD
2=DELETE
3=EDIT
  
```

Detector Screen

■ Add Detector

Pressing 1 while viewing the Detector Screen will display the following screen which allows the programmer to add a new detector address to programming:

```

ADD DETECTOR
ENTER DETECTOR#
***
  
```

Add Detector Screen

A flashing cursor will appear in the position of the first asterisk to the left. The programmer keys in the three digit detector address, such as 005.

When the last digit is keyed-in, the following screen will be displayed:



Press the down arrow key to view additional choices. Press the number corresponding to the desired selection to program that type to the newly added detector.

When the type has been selected, the following screen will be displayed:



The programmer can continue adding detectors by pressing the *ESC* or left arrow key which will return the display to the Add Detector Screen.

■ Delete Detector

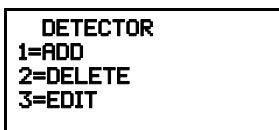

Detector Screen

Pressing 2 in the Detector Screen will display the Delete Detector Screen which allows the programmer to delete a specific detector:



Delete Detector Screen

A flashing cursor will appear in the position of the first asterisk to the left. The programmer keys in the three digit detector address, such as 005. When the last digit is keyed-in, the following screen will be displayed:



The programmer can continue deleting detectors by pressing the *ESC* or left arrow key which will return the display to the Delete Detector Screen.

■ Edit Detector

The programmer can change a detectors existing or factory default programming by pressing 3 in the Detector Screen. The following screen will be displayed:



Edit Detector Screen

A flashing cursor will appear in the position of the first asterisk to the left. The programmer keys in the three digit detector address, such as 017.

When the last digit is keyed-in, if the selected address has not been added to programming, a screen showing information about a device that is installed with a lower address, closest to the selected address, will be displayed.

If no detectors have been installed on the loop, the following will be displayed:



Edit Detector Screen #1

If the selected address has been added to programming, device summary screens will be displayed. These screens allow the programmer to view all device settings at a single glance. Pressing the left or right arrow keys will allow the programmer to rapidly view the devices at the previous or next address (if installed).

If a detector (such as a photoelectric detector) with the selected address is not physically installed on the SLC or has a communication fault but the address is programmed in the system, the following screen will be displayed:

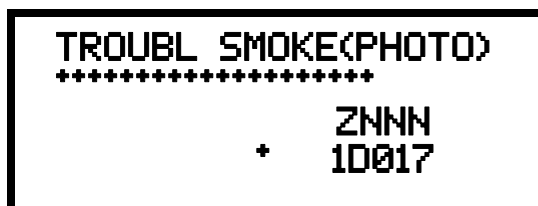

Edit Detector Screen #1

If the selected address has been added to programming and a detector (such as a photoelectric detector) with the selected address is physically installed on the SLC and is communicating with the control panel, the following will be displayed:



Edit Detector Screen #1

To change the programming for the displayed detector, press the keyboard 'down' arrow key to view the Edit Detector screens.

In the preceding example:

- Normal - indicates that the detector with the selected address is physically installed on the SLC and communicating with the control panel (enabled)
- <ADJ><NOUN> - represents the adjective and noun, which have been programmed, describing the location of the displayed device
- ZNNN - represents the first of five possible software zones that the detector is assigned to (NNN = the three digit zone number from 000 - 099)
- V or * - indicates whether or not alarm verification is enabled (V = alarm verification enabled and * = alarm verification disabled)
- 1D017 - represents the Loop, Device type and Device address (1 = SLC Loop 1, D=Detector and 017 = Detector Address 017)

The following examples show the editing of a photoelectric smoke detector with address 017, located on the first SLC loop:



Edit Detector Screen #2

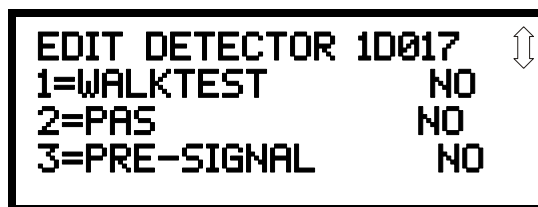

Edit Detector Screen #3

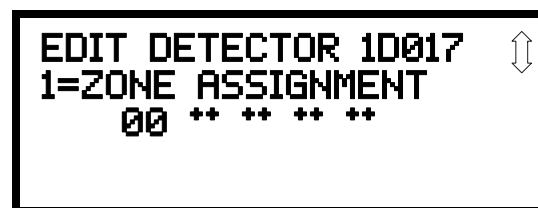

Edit Detector Screen #4



Edit Detector Screen #5

Enable/Disable Detector

To Enable or Disable the detector, press the 1 key while viewing the Edit Detector Screen #2. Each press of the key will toggle the screen between *Enabled Yes* and *Enabled No*. If *Enabled No* is selected, the detector will not be polled by the control panel, preventing the detector from reporting alarms and troubles to the panel. The control panel will display the device type and address which has been disabled and will turn on the Trouble LED and Disable LED.



Edit Detector Screen #2

Type

To select the type of detector being programmed, press the 2 key while viewing the Edit Detector Screen #2. This will cause the control panel to display the following Detector Type Screens:



Detector Type Screen #1

Pressing the down arrow key will display additional detector types as indicated in the following table:

Detector Type	Action When Activated
Smoke Photo	Fire Alarm
User-Defined-1	same as previous (Smoke Photo)
Smoke Ion	Fire Alarm
User-Defined-2	same as previous (Smoke Ion)
Heat Detect	Fire Alarm
User-Defined-3	same as previous (Heat Detect)
Smoke DuctP	Fire Alarm
User-Defined-4	same as previous (Smoke DuctP)
Photo w/Heat	Fire Alarm
User-Defined-5	same as previous (Photo w/Heat)
Duct-Superv	Supervisory, latching
User-Defined-6	same as previous (Superv DuctP)
Photo-SupervAR	Supervisory, nonlatching (works only in LiteSpeed)
User-Defined-7	same as previous (Photo-SupervAR)
ADAPT	Fire Alarm
User-Defined-8	same as previous (ADAPT)
Beam	Fire Alarm
User-Defined-9	same as previous (Beam)

While viewing any Detector Type screen, select the type of detector being programmed by pressing the corresponding keyboard number key. The display will return to Edit Detector Screen #2 and indicate the selection next to the Type option.



NOTE: If a detector is selected as a SUPERV DUCTP type, it will function like a supervisory point, not a fire alarm point. The supervisory LED and supervisory relay will activate, not the fire alarm LED or alarm relay, if smoke is sensed.

Verification

Alarm verification is used to confirm that a smoke detector activation is a true alarm condition and not a false alarm. This feature is selected by pressing 3 while viewing the Edit Detector Screen #2 so that the display reads *Verification On*. Each time the 3 key is pressed, the display will toggle between *Verification On* and *Verification Off*. For a detailed description, refer to “Alarm Verification” on page 159.

Walktest

The Walktest feature allows one person to test the system devices without the necessity of manually resetting the control panel after each device activation. To enable a device for the Walktest feature, press 1 while viewing the Edit Detector Screen #3 until the display reads *Walktest Yes*. Each press of the 1 key will cause the display to toggle between *Walktest Yes* and *Walktest No*. Refer to “Walktest” on page 160.

```

EDIT DETECTOR
1=WALKTEST
2=PAS
3=PRE-SIGNAL

```

Edit Detector Screen #3

PAS

The PAS (Positive Alarm Sequence) option will program the detector to delay panel activation (including alarm relay and communicator) for a period of 15 seconds plus a programmable time of up to 3 minutes. Zone 97, however, will activate immediately and may be used to connect a signaling device to indicate PAS activation (*do not use a Notification Appliance Circuit for this purpose*).

To enable the PAS feature, press 2 while viewing the Edit Detector Screen #3 until the display reads *PAS Yes*. Each press of the 2 key will cause the display to toggle between *PAS Yes* and *PAS No*. Refer to “Positive Alarm Sequence” on page 158.

For example, if a detector with address 005 is to be configured for PAS operation:

- Select *PAS Yes* when editing the detector set to address 005

- Program the desired zone or zones to be activated by this detector, in this example Z001
- Program an output, such as a control module that is to be activated by detector 005 by assigning the same zone to it; in this example Z001
- Program an output, such as a control module, for PAS activation by assigning zone Z97 to it. This control module may be connected to a signaling device used to indicate a PAS condition (*do not use a Notification Appliance Circuit for this purpose*)
- Enable zones Z001 and Special Purpose Zone PAS 97 and set the PAS delay timer to some value

With the preceding program settings, when the detector with address 005 is activated, zone Z97 will cause its associated control module to activate immediately, sounding the connected PAS signaling device. Following the PAS delay time, zone Z001 will cause its associated control module to activate and the control panel will initiate an alarm condition.

Note that a detector can be enabled for either PAS or Pre-signal but not both.

Pre-signal

```
EDIT DETECTOR
1=WALKTEST
2=PAS
3=PRE-SIGNAL
```

Edit Detector Screen #3

The Pre-signal option programs the detector to delay panel activation for a preprogrammed time delay of up to three minutes while allowing for visual verification by a person. Note that the alarm relay and communicator will respond to the initial alarm immediately. In addition, Zone 98 will activate. This zone can be programmed to a control module which may be used to activate a sounder or indicator which the installer designates as a Presignal indication (*do not use a Notification Appliance Circuit for this purpose*). To enable the Pre-signal feature, press 3 while viewing Edit Detector Screen #3 until the display reads *Pre-signal Yes*. Each press of the 3 key will cause the display to toggle between *Pre-signal Yes* and *Pre-signal No*. Refer to “Presignal” on page 158.

For example, if a detector with address 005 is to be configured for Pre-Signal operation:

- Select *Pre-signal Yes* when editing the detector set to address 005.
- Program the desired zone or zones to be activated by this detector, in this example Z001.
- Program an output, such as a control module that is to be activated by detector 005 by assigning the same zone to it; in this example Z001.
- Program an output, such as a control module, for Pre-signal activation by assigning zone Z98 to it. This control module may be connected to a signaling device used to indicate a Pre-signal condition (*do not use a Notification Appliance Circuit for this purpose*).
- Enable zones Z001 and Special Purpose Zone Pre-signal 98 and set the Pre-signal delay timer to some value.

With the preceding program settings, when the detector with address 005 is activated, zone Z98 will cause its associated control module to activate immediately, sounding the connected signaling device to indicate the Pre-signal condition. Following the Pre-signal delay time, zone Z001 will cause its associated control module to activate and the control panel will initiate an alarm condition.

Note that a detector can be enabled for either PAS or Pre-signal but not both.

Zone Assignment

```
EDIT DETECTOR
1=ZONE ASSIGNMENT
00 ** ** ** **
```

Edit Detector Screen #4

A maximum of five zones can be programmed to each addressable detector. Pressing 1 while viewing Edit Detector Screen #4 displays the following screen:

```
ZONE ASSIGNMENT
Z00 Z** Z** Z** Z**
```

Zone Assignment Screen

Note that *Z*** represents the Zone Number(s) corresponding to this device. The factory default for an unprogrammed device is *Z00* for general alarm zone. A flashing cursor will appear on the first *0* to the left. Enter the two digit number corresponding to the zone that is to be assigned to this device. The cursor moves to the next *Z*** designation. Continue entering zone assignments or the remaining zones can be left blank or programmed as general alarm zone *Z00*. When all desired changes have been made, press the Enter key to store the zone assignments. The display will return to the Edit Detector Screen #4. Note that the left and right arrow keys can be used to navigate through the zones and the *CLEAR* key can be used to quickly clear a zone.

Noun/Adjective

```
EDIT DETECTOR
1=NOUN/ADJECTIVE
2=DESCRIPTION
*****
```

Edit Detector Screen #5

The Noun/Adjective selection allows the programmer to enter specific descriptors about the detector currently being programmed. Pressing *1* while viewing Edit Detector Screen #5 will cause the following screen to be displayed:

```
1=STANDARD ADJECTIVE
2=STANDARD NOUN
3=CUSTOM ADJECTIVE
4=CUSTOM NOUN
```

Noun/Adjective Screen

1=STANDARD ADJECTIVE
2=STANDARD NOUN
3=CUSTOM ADJECTIVE
4=CUSTOM NOUN

Noun/Adjective Screen

Pressing 1 while viewing the Noun/Adjective Screen will cause the following screen(s) to be displayed. Note that the keyboard *down* arrow key must be pressed to see all the Adjective screens. Press the number corresponding to the adjective that is to be used as a descriptor for the location of the detector currently being programmed. When an adjective has been selected, it will appear at the top of the display as indicated by the asterisks.

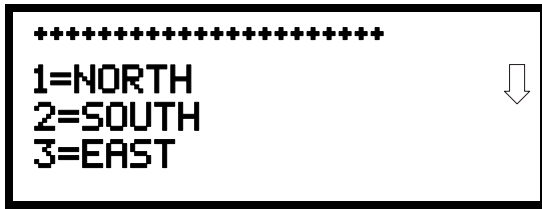

Adjective Screen #1



Adjective Screen #2

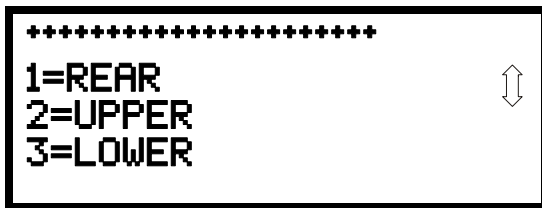

Adjective Screen #3



Adjective Screen #4

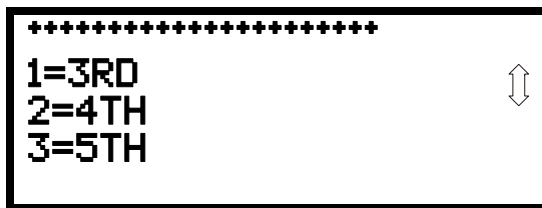

Adjective Screen #5



Adjective Screen #6

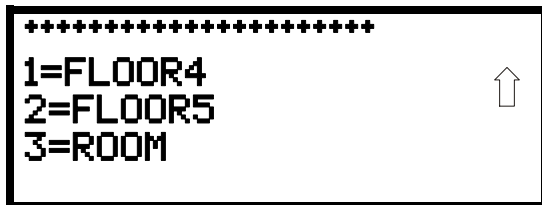

Adjective Screen #7

1=STANDARD ADJECTIVE
 2=STANDARD NOUN
 3=CUSTOM ADJECTIVE
 4=CUSTOM NOUN

Noun/Adjective Screen

Pressing 2 while viewing the Noun/Adjective Screen will cause the following screen(s) to be displayed. Note that the keyboard *down* arrow key must be pressed to see all the Noun screens. Press the number corresponding to the noun that is to be used as a descriptor for the location of the detector currently being programmed. When a noun has been selected, it will appear at the top of the display as indicated by the asterisks.



Noun Screen #1



Noun Screen #2

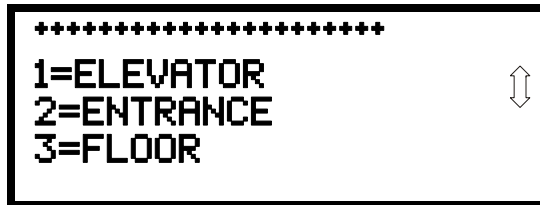

Noun Screen #3



Noun Screen #4



Noun Screen #5



Noun Screen #6



Noun Screen #7

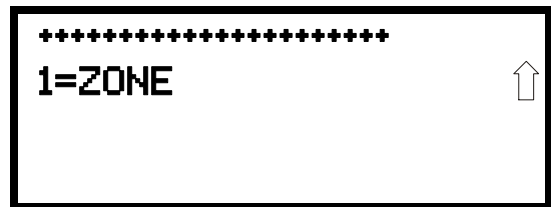

Noun Screen #8

1=STANDARD ADJECTIVE
 2=STANDARD NOUN
 3=CUSTOM ADJECTIVE
 4=CUSTOM NOUN

Noun/Adjective Screen

Pressing 3 or 4 while viewing the Noun/Adjective Screen will display screens similar to the previous Adjective and Noun Screens. The new screens will list custom Adjectives and Nouns which have been programmed into the control panel using the PS-Tools programming kit. These descriptors are selected as described in the previous sections.

Description

EDIT DETECTOR
 1=NOUN/ADJECTIVE
 2=DESCRIPTION

Edit Detector Screen #5

The Description selection allows the programmer to enter additional information about the detector currently being programmed. This information will be displayed as part of the device label on the display. Pressing 2 while viewing Edit Detector Screen #5 will cause the following screen to be displayed:



Adjective/Noun Screen

A flashing cursor will appear at the first asterisk to the left. The programmer can enter additional descriptive information about the device being programmed. This information will appear on the display along with the standard device label information.

A maximum of 20 characters (including spaces) can be entered. To enter alphanumeric characters from the keypad, repeatedly press the appropriate key until the desired character is displayed in the first position. For example, to enter the letter *B*, press the 2 (ABC) key three times to toggle through the characters 2, *A*, and *B*. Press the right arrow key to move the cursor one position to the right and repeat the process to enter the next character. To enter a space, press the * (QZ) key four times until a blank appears in the desired position. When all characters have been entered, press the Enter key to store the information. The display will return to the Edit Detector Screen #5, displaying the new information at the bottom of the screen.

Recall/Increment Function

In addition, the user may use the Recall/Increment function at any time when the cursor is on the first letter of the Description, Adjective or Noun field as follows:

- If the zero key is pressed, a 0 is placed in the first letter position.
- If the zero key is then pressed a second time with no intervening key actions, the entire field is replaced with the field entered *for the previous device programmed*, and the cursor moves to the last character of the field (Recall function). The Recalled Adjective or Noun field may now be changed letter-by-letter.
- If the zero key is pressed again with no other intervening key actions and the last character in the field is a number 0-9, the number is incremented by one. If the last character is a letter, it changes to a 0. If the last character is 9 it goes to 0.
- The above increment function may be repeated with each press of the zero key.

As an example, the user could quickly enter 'FLR_3_ROOM_305' as follows:

1. The cursor is on the first letter of the Adjective field. Press the zero key twice to display *FLR_3*.
2. With the cursor on the first letter of the Noun field, press the zero key twice to recall the display *ROOM_304*. The cursor automatically jumps from the first to the last letter of the Noun field.

3. With the cursor on the last letter of the Noun field, press the zero key again to increment the room number to 305.
4. Press the right arrow key to advance the zone field.
5. Select a zone number from 00 to 99. Z00 (default zone) is the general alarm zone. Z01 through Z99 may be selected to link software zones.

Module Programming

```
POINT PROGRAM
SELECT TYPE
1=DETECTOR
2=MODULE
```

Point Program Screen #2

Pressing 2, while viewing Point Program Screen #2, will allow the programmer to add, delete or change the programming of an addressable module. The following screen will be displayed by the control panel:

```
          MODULES
1=ADD
2=DELETE
3=EDIT
```

Modules Screen

■ Add Module

Pressing 1 while viewing the Modules Screen will display the following screen which allows the programmer to add a new module address to programming:

```
          ADD MODULE
ENTER MODULE#
***
```

Add Module Screen #1

A flashing cursor will appear in the position of the first asterisk to the left. The programmer keys in the three digit module address, such as 005.

When the last digit is keyed-in, the following screen will be displayed:

```
          ADD MODULE
1=CONTROL
2=MONITOR
```

Add Module Screen #2

Pressing *1* for Control Module or *2* for Monitor Module will cause the following screen to be displayed:

```

      ADD MODULE
MODULE#      005
IS ADDED
  
```

Add Module Screen #3

The programmer can continue adding modules by pressing the *ESC* or left arrow key which will return the display to the Add Module Screen #1.

■ Delete Module

Pressing *2* in the Modules Screen will display the Delete Module Screen which allows the programmer to delete a specific module:

```

MODULES
1=ADD
2=DELETE
3=EDIT
  
```

Modules Screen

```

DELETE MODULE
ENTER MODULE#
***
█
  
```

Delete Module Screen

A flashing cursor will appear in the position of the first asterisk to the left. Using the panel keypad, key in the module address such as *005*. When the last digit is keyed in, the following confirmation that the module has been deleted will be displayed:

```

DELETE MODULE
MODULE#      005
IS DELETED
  
```

■ Edit Module Screen for Monitor Module

The programmer can change a modules existing or factory default programming by pressing *3* in the Modules Screen. The following screen will be displayed:

```

EDIT MODULE
ENTER MODULE ADDRESS
***
█
  
```

Edit Module Screen

A flashing cursor will appear in the position of the first asterisk to the left. The programmer keys in the three digit module address, such as *012*. When the last digit is keyed-in, if the selected address has not been added to programming, a screen showing information about a device that is installed with a lower address, closest to the selected address, will be displayed. If no modules are installed on the loop, the following screen will be displayed:

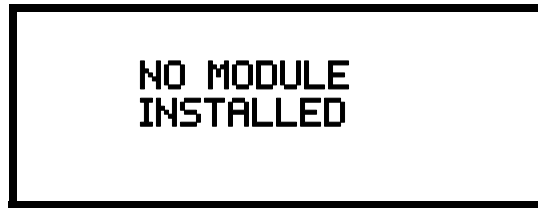

Edit Module Screen

If the selected address has been added to programming but a module (such as a monitor module) with the selected address is not physically installed on the SLC or has a communication fault, the following screen will be displayed:

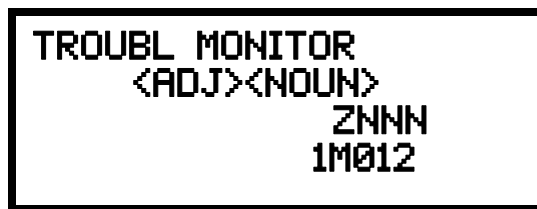

If the selected address has been added to programming and a module (such as a monitor module) with the selected address is physically installed on the SLC and is communicating with the control panel, the following screen will be displayed:



To change the programming for the displayed module, press the keyboard down arrow key to view the following Edit Monitor screens. In the preceding example:

- Normal - indicates that the module with the selected address is physically installed on the SLC and communicating with the control panel (enabled).
- <ADJ><NOUN> - represents the adjective and noun, which have been programmed, describing the location of the displayed device.
- ZNNN - represents the first of five possible software zones that the module is assigned to (NNN = the two digit zone number from 000 - 099).
- 1M012 - represents the Loop, Device type and Device address (1 = SLC Loop 1, M=Module and 012 = Module Address 012).

If the selected address corresponds to a control module, a screen displaying information about the control module with the selected address will be displayed as shown in "Edit Module Screen for Control Modules" on page 88.

If the selected address corresponds to a monitor module, a screen displaying information about the module with the selected address will be displayed as illustrated in the following:

```

NORMAL MONITOR      ↓
  <ADJ><NOUN>
      ZNN
      1M012
  
```

```

EDIT MONITOR 1M012  ↑
1=ENABLED      YES
2=TYPE MONITOR
  
```

Edit Monitor Screen #2

```

EDIT MONITOR 1M012  ↑↓
1=PRE-SIGNAL    NO
  
```

Edit Monitor Screen #3

```

EDIT MONITOR 1M012  ↑↓
1=WALKTEST      YES
2=ZONE ASSIGNMENT
  00 ** ** ** **
  
```

Edit Monitor Screen #4

```

EDIT MONITOR 1M012  ↑
1=ADJECTIVE/NOUN
2=DESCRIPTION
*****
  
```

Edit Monitor Screen #5

Enable/Disable Module

To Enable or Disable the monitor module, press the *I* key while viewing the Edit Module Screen #2. Each press of the key will toggle the screen between *Enabled Yes* and *Enabled No*. If *Enabled No* is selected, the module will not be polled by the control panel, preventing the module from reporting alarms and troubles to the panel. The control panel will indicate a system trouble condition and the Disable LED will turn on if any devices are disabled.

```
EDIT MONITOR
1=ENABLED
2=TYPE MONITOR
```

Edit Monitor Screen #2

Type Monitor

The FACP response to the activation of a user-defined type is the same as most previous standard types in the list, thus allowing a variety of user-defined types and responses. To select the type of monitor module being programmed, press the 2 key while viewing the Edit Monitor Screen #2. This will cause the control panel to display the following Monitor Type Screens:

```
MONITOR TYPE
1=PULL-STATION
2=USER-DEFINED-1
3=WATERFLOW
```



Monitor Type Screen #1

Pressing the down arrow key will display additional Monitor Type screens. While viewing one of the Monitor Type screens, select the type of monitor module being programmed by pressing the corresponding keypad number key. The display will return to the Edit Monitor Screen #2 which will show the new type selection.

Table 3.1 lists the Monitor Types and their respective functions.

Monitor module type selection will affect the function of the point as follows:

Monitor Type	Action When Activated
Pull-Station	Fire Alarm
User-Defined-1	same as previous (Pull-Station)
Waterflow	Fire Alarm Delayed
User-Defined-2	same as previous (Waterflow)
Monitor	Fire Alarm
User-Defined-3	same as previous (Monitor)
Future	not used
Future	not used
Smoke-Conventional ¹	Fire Alarm
User-Defined-5	same as previous (Smoke-Conventional)
Heat-Conventional	Fire Alarm
User-Defined-6	same as previous (Heat-Detector)
Medic-Alert ²	Supervisory, latching
User-Defined-7	same as previous (Medic-Alert)
Hazard-Alert ²	Supervisory, latching
User-Defined-8	same as previous (Hazard-Alert)
Tornado-Alert ²	Supervisory, latching
User-Defined-9	same as previous (Tornado-Alert)
Phone	Active Phone (LCD display only)
User-Defined-10	same as previous (Phone)
Tamper	Supervisory, nonlatching (tracking)
User-Defined-11	same as previous (Tamper)
Supervisory	Supervisory, latching
User-Defined-12	same as previous (Supervisory)
Supervisory-AR ³	Supervisory, nonlatching (tracking)
User-Defined-13	same as previous (Supervisory-AR)
HVAC OVRRIDE ⁴	Switch Supervisory, nonlatching (tracking)
Power-Monitor	Power Fault
User-Defined-14	same as previous (Power Monitor)
Trouble-Monitor	Trouble
User-Defined-15	same as previous (Trouble Monitor)
Process-Monitor ²	Piezo
User-Defined 16	same as previous (Process-Monitor)
Process-Monitor-AR ^{2, 3}	Piezo, nonlatching (tracking)
User-Defined-17	same as previous (Process-Monitor-AR)
Future	not used
Future	not used
Ack-Switch	Acts like panel Acknowledge Key
Sil-Switch	Acts like panel Silence Key
Reset-Switch	Acts like panel Reset Key
Drill-Switch	Acts like panel Drill Key
PAS-Bypass	PAS Disable
HVAC RESTART ⁴	Switch
Drill-Switch-AR ³	Drill Switch, nonlatching (tracking)

Table 3.1 Monitor Types

- 1 Conventional 2-wire smoke detectors may be powered using an external power supply with an SLC Control Relay Module programmed for *Resettable Power* operation (refer to note 1 on page 89).
- 2 Combination systems employing these non-fire monitor types require the SLC loop to be programmed by the installer for Style 4 operation **and** isolator modules must be employed on each non-fire branch of the SLC as per Figure 13 in the Fire-Lite SLC Wiring Manual (document number 51309). Fire and non-fire devices must not be used on the same SLC branch.
- 3 For all entries ending in AR, AR refers to AutoResettable.
- 4 For HVAC RESTART and HVAC OVRRIDE descriptions, refer to "Monitor Module Operation" on page 198.

```
EDIT MONITOR
1=PRE-SIGNAL
```

Edit Monitor Screen #3

Pre-signal

To enable the Pre-signal feature, press *1* while viewing Edit Monitor Screen #3 until the display reads *Pre-signal Yes*. Each press of the *1* key will cause the display to toggle between *Pre-signal Yes* and *Pre-signal No*. Refer to “Presignal” on page 158 for additional information.

```
EDIT MONITOR
1=WALKTEST
2=ZONE ASSIGNMENT
00 ** ** ** **
```

Edit Monitor Screen #4

Walktest

The Walktest feature allows one person to test the system devices without the necessity of manually resetting the control panel after each device activation. To enable devices, which are connected to a monitor module, for the Walktest feature, press *1* while viewing the Edit Monitor Screen #4 until the display reads *Walktest Yes*. Each press of the *1* key will cause the display to toggle between *Walktest Yes* and *Walktest No*. Refer to “Walktest” on page 160 for additional information.

Zone Assignment

A maximum of five zones can be programmed to each addressable monitor module. Pressing *2* while viewing Edit Monitor Screen #4 displays the following screen:

```
MON ZONE ASSIGN
Z00 Z** Z** Z** Z**
```

Zone Assignment Screen

Note that *Z*** represents the Zone Number(s) corresponding to this device. The factory default for an unprogrammed device is *Z00* for general alarm zone. A flashing cursor will appear on the first *0* to the left. Enter the two digit number corresponding to the zone that is to be assigned to this device. The cursor moves to the next *Z*** designation. Continue entering zone assignments or the remaining zones can be left blank or programmed as general alarm zones *Z00*. When all desired changes have been made, press the Enter key to store the zone assignments. The display will return to the Edit Monitor Screen #4.

```
EDIT MONITOR
1=NOUN/ADJECTIVE
2=DESCRIPTION
*****
```

Edit Monitor Screen #5

Noun/Adjective

The Noun/Adjective selection allows the programmer to enter specific descriptors about the monitor module currently being programmed. Pressing *1* while viewing Edit Monitor Screen #5 will cause the following screen to be displayed:

```
1=STANDARD ADJECTIVE
2=STANDARD NOUN
3=CUSTOM ADJECTIVE
4=CUSTOM NOUN
```

Noun/Adjective Screen

1=STANDARD ADJECTIVE
2=STANDARD NOUN
3=CUSTOM ADJECTIVE
4=CUSTOM NOUN

Noun/Adjective Screen

Pressing 1 while viewing the Noun/Adjective Screen will cause the following screen(s) to be displayed. Note that the keyboard *down* arrow key must be pressed to see all the Adjective screens. Press the number corresponding to the adjective that is to be used as a descriptor for the location of the monitor module currently being programmed.

```
*****  
1=NORTH  
2=SOUTH  
3=EAST
```

Adjective Screen #1

```
*****  
1=WEST  
2=FRONT  
3=CENTER
```

Adjective Screen #2

```
*****  
1=REAR  
2=UPPER  
3=LOWER
```

Adjective Screen #3

```
*****  
1=MAIN  
2=FIRST  
3=2ND
```

Adjective Screen #4

```
*****  
1=3RD  
2=4TH  
3=5TH
```

Adjective Screen #5

```
*****  
1=FLOOR 1  
2=FLOOR 2  
3=FLOOR 3
```

Adjective Screen #6

```
*****  
1=FLOOR 4  
2=FLOOR 5  
3=ROOM
```

Adjective Screen #7

1=STANDARD ADJECTIVE
 2=STANDARD NOUN
 3=CUSTOM ADJECTIVE
 4=CUSTOM NOUN

Pressing 2 while viewing the Noun/Adjective Screen will cause the following screen(s) to be displayed. Note that the keyboard *down* arrow key must be pressed to see all the Noun screens. Press the number corresponding to the noun that is to be used as a descriptor for the location of the monitor module currently being programmed.

Noun/Adjective Screen



Noun Screen #1

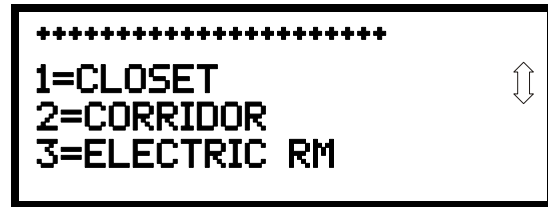

Noun Screen #2



Noun Screen #3



Noun Screen #4

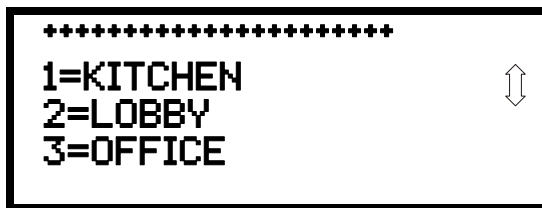

Noun Screen #5



Noun Screen #6



Noun Screen #7

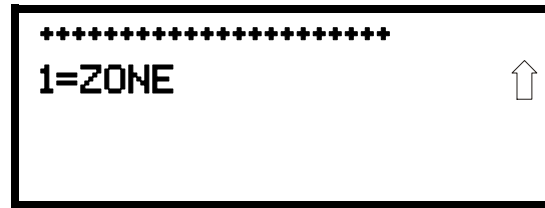

Noun Screen #8

Pressing 3 or 4 while viewing the Noun/Adjective Screen will display screens similar to the previous Adjective and Noun Screens. The new screens will list Custom Adjectives and Nouns which have been programmed into the control panel using the PS-Tools programming kit.

```

EDIT MONITOR
1=NOUN/ADJECTIVE
2=DESCRIPTION
*****

```

Edit Monitor Screen #5

Description

The Description selection allows the programmer to enter additional information about the monitor module currently being programmed. This information will be displayed as part of the device label on the LCD display. Pressing 2 while viewing Edit Monitor Screen #5 will cause the following screen to be displayed:

```

DESCRIPTION      1M012
NOUN/ADJECTIVE
*****

```

Noun/Adjective Screen

A flashing cursor will appear at the first asterisk to the left. The programmer can enter additional descriptive information about the device being programmed. This information will appear on the LCD display along with the standard device label information.

A maximum of 20 characters (including spaces) can be entered. To enter alphanumeric characters from the keypad, repeatedly press the appropriate key until the desired character is displayed in the first position. For example, to enter the letter *B*, press the 2 (*ABC*) key three times to toggle through the characters 2, *A*, and *B*. Press the right arrow key to move the cursor one position to the right and repeat the process to enter the next character. To enter a space, press the * (*QZ*) key four times until a blank appears in the desired position. When all characters have been entered, press the Enter key to store the information. The display will return to the Edit Monitor Screen #4, displaying the new information at the bottom of the screen.

Recall/Increment Function

In addition, the user may use the Recall/Increment function at any time when the cursor is on the first letter of the Adjective or Noun field as follows:

- If the zero key is pressed, a 0 is placed in the first letter position.
- If the zero key is then pressed a second time with no intervening key actions, the entire Adjective field is replaced with the field entered *for the previous device programmed*, and the cursor moves to the last character of the field (Recall function). The Recalled Adjective or Noun field may now be changed letter-by-letter.
- If the zero key is pressed again with no other intervening key actions and the last character in the field is a number 0-9, the number is incremented by one. If the last character is a letter, it changes to a 0. If the last character is 9 it goes to 0.
- The above increment function may be repeated with each press of the zero key.

As an example, the user could quickly enter 'FLR_3_ROOM 305' as follows:

1. The cursor is on the first letter of the Adjective field. Press the zero key twice to display *FLR_3*.
2. With the cursor on the first letter of the Noun field, press the zero key twice to recall the display *ROOM_304*. The cursor automatically jumps from the first to the last letter of the Noun field.
3. With the cursor on the last letter of the Noun field, press the zero key again to increment the room number to *305*.
4. Press the right arrow key to advance the zone field.
5. Select a zone number from 00 to 99. Z00 (default zone) is the general alarm zone. Z01 through Z99 may be selected to link software zones.

■ Edit Module Screen for Control Modules

The programmer can change a module's existing or factory default programming by pressing 3 in the Modules Screen. The following screen will be displayed:

```

MODULES
1=ADD
2=DELETE
3=EDIT

```

Modules Screen

```

          EDIT MODULE
ENTER MODULE ADDRESS
***

```

Edit Module Screen

A flashing cursor will appear in the position of the first asterisk to the left.

The programmer keys in the three digit module address, such as 002. When the last digit is keyed in, if the selected address corresponds to a *control* module, a screen displaying information about the control module with the selected address will be displayed as illustrated in the following:

```

NORMAL      CONTROL  ↓
      <ADJ><NOUN>
      SW  ZNNN
      1M002

```

Edit Control Screen #1

In the preceding example:

- Normal - indicates that the module with the selected address is physically installed on the SLC and communicating with the control panel (enabled).
- <ADJ><NOUN> - represents the adjective and noun, which have been programmed, describing the location of the displayed device.
- Control - indicates that the selected module is a control module.
- S or * - represents Silenceable (S) or Nonsilenceable (*).
- W or * - represents Waterflow Timer Delay (W = Waterflow Timer Delay enabled, * = Waterflow Timer Delay disabled).
- ZNNN - represents the first of five possible software zones that the module is assigned to (NNN = the three digit zone number from 000 - 099).
- 1M002 - represents the Loop, Device type and Device address (1 = SLC Loop 1, M=Module and 002 = Module Address 02).

To change the programming for the displayed module, press the keyboard *down* arrow key to view the following Edit Control screens:

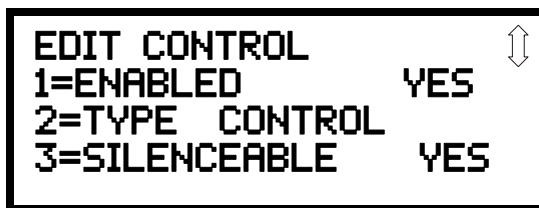

Edit Control Screen #2

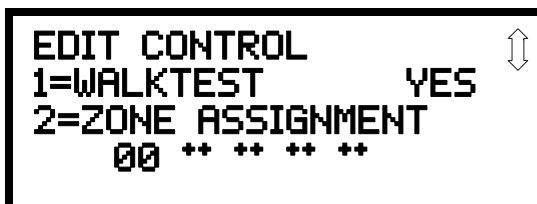

Edit Control Screen #3



Edit Control Screen #4

Enable/Disable Module

To Enable or Disable the control module, press the *1* key while viewing the Edit Control Screen #2. Each press of the key will toggle the screen between *Enabled Yes* and *Enabled No*. If *Enabled No* is selected, the module will not be polled by the control panel, preventing the module from activating its output devices. The control panel will indicate a system trouble condition and the Disable LED will turn on if any devices are disabled.

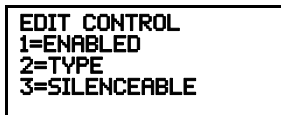

Edit Control Screen #2

Type

To select the type of control module being programmed, press the *2* key while viewing the Edit Control Screen #2. This will cause the control panel to display the following Control Type Screens. Press the down arrow key to view additional screens and selections.

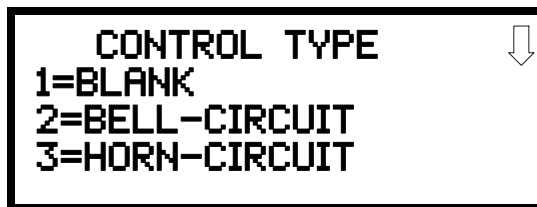

Control Type Screen #1

While viewing one of the Control Type screens, select the type of control module being programmed by pressing the corresponding keypad number key. The display will return to the Edit Control Screen #2 and indicate the new type selection.



NOTE: A control relay module set to the Resettable Power type will follow the main circuit board 24 VDC resettable power unless the control relay module is disabled.

The following table contains control module type codes and their functions which are displayed in the Control Type screens:

Control Type	Special Function
Bell Circuit	NAC Type - supervised
Horn Circuit	NAC Type - supervised
Sounders	NAC Type - supervised
Relay	Ignore Open Circuit
Strobe Circuit	NAC Type - supervised
Control	NAC Type - supervised
Resettable Power ¹	Relay Type - Ignore Open Circuit
HVAC SHUTDN ²	Relay Type - Ignore Open Circuit

- 1 When using a control relay module to supply resettable power to conventional 2-wire smoke detectors, the MMF-302 monitor module must be set for smoke-conventional operation.
- 2 For HVAC SHUTDN description, refer to “Control Module Operation” on page 198.

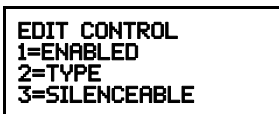

Edit Control Screen #2

Silenceable

The Silenceable selection allows the programmer to select whether output devices connected to the control module can be silenced, either by pressing the Alarm Silence key or by enabling Autosilence. Pressing the 3 key while viewing Edit Control Screen #2 will enable the Silenceable feature causing the display to read *Silenceable Yes*. Repeated presses of the 3 key will cause the display to toggle between *Silenceable Yes* and *Silenceable No*.

Note that nonsilenceable outputs will not be activated for Fire Drill.



Edit Control Screen #3

Walktest

The Walktest feature allows one person to test the system devices without the necessity of manually resetting the control panel after each device activation. To enable devices, which are connected to a control module, for the Walktest feature, press 1 while viewing the Edit Control Screen #3 until the display reads *Walktest Yes*. Each press of the 1 key will cause the display to toggle between *Walktest Yes* and *Walktest No*. Refer to “Walktest” on page 160 for additional information.

Zone Assignment

A maximum of five zones can be programmed to each addressable control module. Pressing 2 while viewing Edit Control Screen #3 displays the following screen:

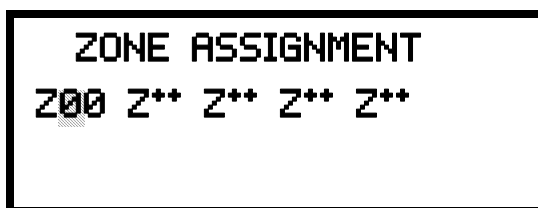

Zone Assignment Screen

Note that Z** represents the Zone Number(s) corresponding to this device. The factory default for an unprogrammed device is Z00 for general alarm zone. A flashing cursor will appear on the first 0 to the left. Enter the two digit number corresponding to the zone that is to be assigned to this device. The cursor moves to the next Z** designation. Continue entering zone assignments or the

remaining zones can be left blank or programmed as general alarm zones Z00. When all desired changes have been made, press the Enter key to store the zone assignments. The display will return to the Edit Control Screen #3.

```
EDIT CONTROL
1=NOUN/ADJECTIVE
2=DESCRIPTION
```

Edit Control Screen #4

Noun/Adjective

The Noun/Adjective selection allows the programmer to enter specific descriptors about the control module currently being programmed. Pressing *1* while viewing Edit Control Screen #4 will cause the following screen to be displayed:

```
1=STANDARD ADJECTIVE
2=STANDARD NOUN
3=CUSTOM ADJECTIVE
4=CUSTOM NOUN
```

Noun/Adjective Screen

1=STANDARD ADJECTIVE
 2=STANDARD NOUN
 3=CUSTOM ADJECTIVE
 4=CUSTOM NOUN

Pressing *1* while viewing the Noun/Adjective Screen will cause the following screen(s) to be displayed. Note that the keyboard *down* arrow key must be pressed to see all the Adjective screens. Press the number corresponding to the adjective that is to be used as a descriptor for the location of the control module currently being programmed.

Noun/Adjective Screen

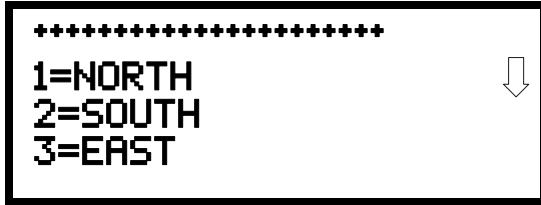

Adjective Screen #1



Adjective Screen #2



Adjective Screen #3



Adjective Screen #4

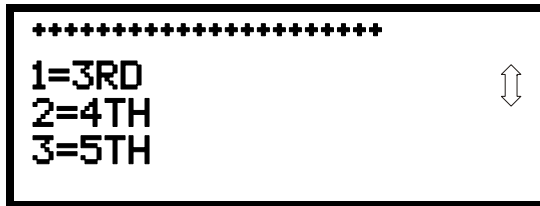

Adjective Screen #5

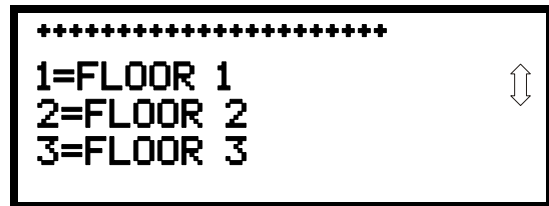

Adjective Screen #6

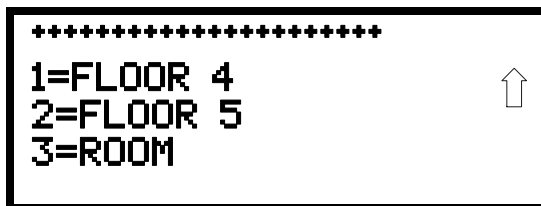

Adjective Screen #7

1=STANDARD ADJECTIVE
 2=STANDARD NOUN
 3=CUSTOM ADJECTIVE
 4=CUSTOM NOUN

Pressing 2 while viewing the Noun/Adjective Screen will cause the following screen(s) to be displayed. Note that the keyboard *down* arrow key must be pressed to see all the Noun screens. Press the number corresponding to the noun that is to be used as a descriptor for the location of the control module currently being programmed.

Noun/Adjective Screen

```
*****
1=BASEMENT
2=BOILER RM
3=CLASSROOM
```

Noun Screen #1

```
*****
1=CLOSET
2=CORRIDOR
3=ELECTRIC RM
```

Noun Screen #2

```
*****
1=ELEVATOR
2=ENTRANCE
3=FLOOR
```

Noun Screen #3

```
*****
1=GARAGE
2=HALLWAY
3=HVAC RM
```

Noun Screen #4

```
*****
1=KITCHEN
2=LOBBY
3=OFFICE
```

Noun Screen #5

```
*****
1=PATIENT
2=RESTROOM
3=ROOM
```

Noun Screen #6

```
*****
1=STAIRWAY
2=STOREROOM
3=WING
```

Noun Screen #7

```
*****
1=ZONE
```

Noun Screen #8

Pressing 3 or 4 while viewing the Noun/Adjective Screen will display screens similar to the previous Adjective and Noun Screens. The new screens will list Custom Adjectives and Nouns which have been programmed into the control panel using the PS-Tools programming kit.

EDIT CONTROL
1=ADJECTIVE/NOUN
2=DESCRIPTION

Edit Control Screen #4

Description

The Description selection allows the programmer to enter additional information about the control module currently being programmed. This information will be displayed as part of the device label on the display. Pressing 2 while viewing Edit Control Screen #4 will cause the following screen to be displayed:

```

DESCRIPTION      1M002
NOUN/ADJECTIVE
*****
  
```

Adjective/Noun Screen

A flashing cursor will appear at the first asterisk to the left. The programmer can enter additional descriptive information about the device being programmed. This information will appear on the display along with the standard device label information.

A maximum of 20 characters (including spaces) can be entered. To enter alphanumeric characters from the keypad, repeatedly press the appropriate key until the desired character is displayed in the first position. For example, to enter the letter *B*, press the 2 (*ABC*) key three times to toggle through the characters *I*, *A*, and *B*. Press the right arrow key to move the cursor one position to the right and repeat the process to enter the next character. To enter a space, press the * (*QZ*) key four times until a blank appears in the desired position. When all characters have been entered, press the Enter key to store the information. The display will return to the Edit Control Screen #4, displaying the new information at the bottom of the screen.

Recall/Increment Function

In addition, the user may use the Recall/Increment function at any time when the cursor is on the first letter of the Adjective or Noun field as follows:

- If the zero key is pressed, a 0 is placed in the first letter position.
- If the zero key is then pressed a second time with no intervening key actions, the entire Adjective field is replaced with the field entered *for the previous device programmed*, and the cursor moves to the last character of the field (Recall function). The Recalled Adjective or Noun field may now be changed letter-by-letter.
- If the zero key is pressed again with no other intervening key actions and the last character in the field is a number 0-9, the number is incremented by one. If the last character is a letter, it changes to a 0. If the last character is 9 it goes to 0.
- The above increment function may be repeated with each press of the zero key.

As an example, the user could quickly enter 'FLR_3_ROOM 305' as follows:

1. The cursor is on the first letter of the Adjective field. Press the zero key twice to display *FLR_3*.
2. With the cursor on the first letter of the Noun field, press the zero key twice to recall the display *ROOM_304*. The cursor automatically jumps from the first to the last letter of the Noun field.
3. With the cursor on the last letter of the Noun field, press the zero key again to increment the room number to *305*.
4. Press the right arrow key to advance the zone field.
5. Select a zone number from 00 to 99. Z00 (default zone) is the general alarm zone. Z01 through Z99 may be selected to link software zones.

3.6.3 Zone Setup

```

PROGRAMMING
1=AUTOPROGRAM
2=POINT PROGRAM
3=ZONE SETUP
    
```

Programming Screen #2

Pressing 3 while viewing Programming Screen #1 will access the Zone Setup screens as illustrated below:

```

ZONE SETUP
1=ENABLE
2=DISABLE
3=ZONE 97 98 99
    
```

Zone Setup Screen #1

```

ZONE SETUP
1=ZONES INSTALLED
2=ZONES ENABLED
3=ZONES DISABLED
    
```

Zone Setup Screen #2

```

ZONE SETUP
1=ZONE TYPES
2=ZONES AVAILABLE
3=ZONE MESSAGE
    
```

Zone Setup Screen #3

```

ZONE SETUP
1=ENABLE
2=DISABLE
3=ZONE 97 98 99
    
```

Zone Setup Screen #1

Enable

Pressing 1 for Enable, while viewing Zone Setup Screen #1, will display the following screen:

```

ZONE TO ENABLE
Z
    
```

Enable Screen

This screens allows the programmer to enable zones, one at a time. A flashing cursor appears next to the Z, prompting the programmer to enter a two digit zone number (01 - 99). When the second digit is entered, the zone will be enabled and the cursor returns to the original position next to the Z. Another zone can then be enabled.

```

ZONE SETUP
1=ENABLE
2=DISABLE
3=ZONE 97 98 99

```

Zone Setup Screen #1

Disable

Pressing 2 for Disable, while viewing Zone Setup Screen #1, will display the following screen:

```

ZONE TO DISABLE
Z

```

Disable Screen

This screen allows the programmer to disable zones, one at a time. A flashing cursor appears next to the Z, prompting the programmer to enter a two digit zone number (01 - 99). When the second digit is entered, the zone will be disabled and the cursor will return to the original position next to the Z. Another zone can then be disabled.

Zone 97, 98 and 99

Pressing 3 for Zone 97, 98 and 99, while viewing Zone Setup Screen #1, will display the following screen:

```

SPEC PURPOSE ZONE
1=PAS 97      OFF
2=PRE SIGNAL 98 OFF
3=TWO STAGE 99 OFF

```

Zone 97, 98 and 99 Screen

Zones 97, 98 and 99 can be programmed for normal zone operation or for special purpose applications. In the above illustration, the three zones are shown Off, which means they can be programmed to function in the same manner as all other zones, by assigning them to input and output devices in the Programming Zone Assignment Screen.

Pressing 1 will cause the display to change to *PAS 97 On*. Each press of the 1 key will cause the display to toggle between *PAS 97 On* and *PAS 97 Off*. When Zone 97 is programmed On, a PAS (Positive Alarm Sequence) activation of any detector will cause Zone 97 to activate. By assigning Zone 97 to a control module in the Programming Zone Assignment Screen, an output device connected to the control module can be used to indicate a PAS condition in the control panel. *Do not assign Zone 97 to a Notification Appliance Circuit when using this zone to indicate a PAS condition.*

Pressing 2 will cause the display to change to *Pre-signal 98 On*. Each press of the 2 key will cause the display to toggle between *Pre-signal 98 On* and *Pre-signal 98 Off*. When Zone 98 is programmed On, a Pre-signal activation of any device will cause Zone 98 to activate. By assigning Zone 98 to a control module in the Programming Zone Assignment Screen, an output device connected to the control module can be used to indicate a Pre-signal condition in the control panel. *Do not assign Zone 98 to a Notification Appliance Circuit when using this zone to indicate a Pre-signal condition.*

Pressing 3 will cause the display to change to *Two Stage 99 On*. Each press of the 3 key will cause the display to toggle between *Two Stage 99 On* and *Two Stage 99 Off*. Refer to “Two Stage Operation” on page 111 for a description of this feature.

```

ZONE SETUP
1=ZONES INSTALLED
2=ZONES ENABLED
3=ZONES DISABLED
Zone Setup Screen #2

```

Zones Installed

Pressing 1 for Zones Installed, while viewing Zone Setup Screen #2, will display a screen similar to the following:

```

      ZONES INSTALLED
00 01 02 03 04 05

```

Zones Installed Screen

This display will show all of the zones that have been programmed into the control panel. Note that an up and/or down arrow may appear in the upper right corner of the display, indicating that additional screens of zone information exists. Press the up or down arrow keys to view the additional zones.

Zones Enabled

Pressing 2 for Zones Enabled, while viewing Zone Setup Screen #2, will display a screen similar to the following:

```

      ZONES ENABLED
00 01 02 04 05 06 07
08 09 10 11 12 13 14
15 16 17 18 19 20 21

```

Zones Enabled Screen

This display will show all of the zones that are enabled in the control panel. Note that an up and/or down arrow may appear in the upper right corner of the display, indicating that additional screens of zone information exists. Press the up or down arrow keys to view the additional zones.

Zones Disabled

Pressing 3 for Zones Disabled, while viewing Zone Setup Screen #2, will display a screen similar to the following:

```

      ZONES DISABLED
03

```

Zones Disabled Screen

This display will show all of the zones that are disabled in the control panel. Note that an up and/or down arrow may appear in the upper right corner of the display, indicating that additional screens of zone information exists. Press the up or down arrow keys to view the additional zones.

ZONE SETUP
1=ZONE TYPES
2=ZONES AVAILABLE
3=ZONE MESSAGE

Zone Setup Screen #3

Zone Type

Zone Types must be programmed only if a DACT, programmed for zone reporting, is installed on the control panel. Pressing 1 for Zone Types, while viewing Zone Setup Screen #3, will display a screen similar to the following:

```

ZONE TYPE PROG
1=Z00 MONITOR
2=Z01 MONITOR
3=Z02 MONITOR
    
```

Zones Installed Screen

This display will show the system zones (default and user programmed) and their associated types. Note that an up and/or down arrow will appear in the upper right corner of the display, indicating that additional screens of zone information exists. Press the up or down arrow keys to view zones Z00 through Z99.

Zone types can be changed by pressing the keypad number key corresponding to the zone in each Zones Installed Screen. Available zone types will be displayed in the resultant screens. For example, to change the zone type for zone Z02 in the screen illustrated above, press 3. The following screens will be displayed:

```

ZONE TYPE PROG
1=MONITOR
2=SMOKE PHOTO
3=WATERFLOW
    
```

Zone Type Program Screen #1

```

ZONE TYPE PROG
1=HEAT
2=PULL STATION
3=DUCT
    
```

Zone Type Program Screen #2

```

ZONE TYPE PROG
1=MEDICAL
2=HAZARD
3=TAMPER
    
```

Zone Type Program Screen #3

```

ZONE TYPE PROG
1=SUPERVISORY
2=PROC. MON
3=SMOKE ION
    
```

Zone Type Program Screen #4

To change the zone type for Z02 to Pull Station, scroll the display until Zone Type Program Screen #2 is displayed. Press 2 to program zone Z02 as a Pull Station zone. The display will return to the Zones Installed Screen showing zone Z02 and the Pull Station program type. Repeat the procedure for each zone to be changed.

IMPORTANT! In Zone Type Program Screen #1, selecting WATERFLOW will assign a Waterflow silenceable zone type to the selected zone. Any signaling devices programmed to the same zone can be silenced by pressing the Alarm Silence key or by using the auto-silence feature.

To program a waterflow circuit as nonsilenceable, refer to “System Setup” on page 100.



NOTE: Zone Types are only relevant for Central Station reporting. Changing a zone type will only change how it is reported to the Central Station.

```

ZONE SETUP
1=ZONE TYPES
2=ZONES AVAILABLE
3=ZONE MESSAGE

```

Zone Setup Screen #3

Zones Available

Pressing 2 while viewing Zone Setup Screen #3 will display the following screen:

```

ZONES AVAILABLE
01 02 03 04 05 06 07
08 09 10 11 12 13 14
15 16 17 18 19

```

The display will show all of the zones that are still available for programming. Note that an up and/or down arrow may appear in the upper right corner of the display, indicating that additional screens of zone information exists. Press the up or down arrow key to view additional screens.

3.6.4 Loop Setup

Loop Setup allows the programmer to configure the SLC Loop(s) for NFPA Style 4, 6 or 7 wiring and to select the protocol for each loop. Pressing 1 while viewing Programming Screen #2 will cause the following screen to be displayed:

```

PROGRAMMING
1=LOOP SETUP
2=SYSTEM SETUP
3=VERIFY LOOPS

```

Programming Screen #2

```

LOOP SETUP
1=LOOP 1
2=LOOP 2
3-PROTOCOL CLIP

```

Loop Selection Screen

Loop Selection

Press 1 while viewing the Loop Selection Screen to configure Loop1 or 2 to configure Loop 2. The following screens will appear for each loop.

```

LOOP # SETUP
1=STYLE 4

```

Loop Setup Screen

■ Style

To program the SLC Style for the selected loop, press 1 for Style, while viewing Loop Setup Screen. In the preceding example, the control panel is programmed for Style 4 SLC wiring as indicated by the 4 to the right of *Style* in the display. To change the wiring style, press 1 to toggle the display to read *Style 6*. Each press of the 1 key will cause the display to toggle between *Style 4* and *Style 6*. Note that, when programming the Loop Style, the programmer can only select between *Style 4* and *Style 6*. To program a system for *Style 7* wiring, the programmer must select the Loop Setup for *Style 6*. *Style 7* wiring is the same as *Style 6* with the added requirement that each addressable device on the loop must have a pair of isolator modules, one on each side.

Note on SLC Troubles: If the FACP reports an open fault on an SLC Loop programmed for Style 6, the trouble condition will latch at the FACP. When the SLC Loop has been repaired, the *Reset* button must be pressed at the FACP (at least 2 minutes after the trouble has been repaired) to clear the SLC trouble.

Loop Protocol

Loop Protocol refers to the SLC loop mode of operation. Refer to “Wire Requirements” on page 196 for wire specifications based upon SLC protocol. Two modes of operation are available: LiteSpeed and CLIP mode. CLIP mode (Classic Loop Interface Protocol) is used for the older legacy addressable devices such as the M300 Series modules and detectors. LiteSpeed mode is used for newer addressable devices such as the 350 series (or newer) for quicker response times. Note that the legacy devices can operate only in CLIP mode while the newer devices are compatible with both modes of operation. Pressing 3 while viewing the Loop Setup Screen will allow the programmer to select between CLIP and LiteSpeed mode. Each press of the 3 key will toggle the setting between CLIP and LiteSpeed mode.

Device Addressing

It is important to note that the FACP addressable device capacity is 159 detectors and 159 control/monitor modules per SLC loop. Since older legacy addressable devices cannot be set to addresses above 099, the newer series devices must be used when addresses 100 to 159 are to be installed. It is permissible to mix old and new devices in the same panel, however, the FACP must be programmed for CLIP mode.

3.6.5 System Setup

System Setup allows the programmer to configure the following control panel features:

- *Trouble Reminder*: This feature, when enabled, provides an audible reminder that an alarm or trouble still exists on the FACP after the control panel has been silenced. The control panel piezo sounder will pulse once every 15 seconds during an alarm and every two minutes during a trouble condition, after the Alarm Silence or Acknowledge key is pressed. The piezo will continue to sound at these rates until the alarm or trouble condition is cleared. If the trouble condition is not cleared within 24 hours, the panel will reactivate the trouble sounder and retransmit the trouble condition to the central station if connected.
- *Banner*: This option allows the user to change the top line of the LCD display from the blank factory default readout to a user defined readout when the control panel is in Normal condition.
- *Time-Date*: This feature allows the programmer to set the time, display format (24 hr or 12 hr), date and daylight savings time feature into the FACP memory
- *Timers*: This option allows the programmer to set the PAS (Positive Alarm Sequence) time delay, Pre-Signal time delay and Waterflow time delay.
- *NACs*: This feature allows the programmer to configure the control panel Notification Appliance Circuits for a variety of options, such as circuit type, silenceable/nonsilenceable, autosilence, coding, silence inhibit, zone assignment and enable/disable.
- *Relays*: This option allows programming of two onboard relays for activation by various control panel events, such as alarm, trouble, supervisory, etc.
- *Canadian Option*: This option allows the automatic programming of the FACP to Canadian specifications (refer to “Canadian Option” on page 113).
Important! For Canadian Applications, this option must be set to ON prior to any other panel programming.
- *Waterflow Silenceable*: This option provides the ability to silence any output circuit activated by a monitor module programmed as a waterflow type.

PROGRAMMING
1=LOOP SETUP
2=SYSTEM SETUP
3=VERIFY LOOPS

Programming Screen #2

Pressing 2 for System Setup, while viewing Programming Screen #2, will cause the following screens to be displayed:

SYSTEM SETUP ↓
1=TROUBLE REM OFF
2=BANNER
3=TIME-DATE

System Setup Screen #1

SYSTEM SETUP ↑↓
1=TIMERS
2=NAC
3=RELAYS

System Setup Screen #2

SYSTEM SETUP ↑
1=CANADIAN OPT. OFF
2=WATERFLOW SIL. NO

System Setup Screen #3

Trouble Reminder

The Trouble Reminder features causes the control panel piezo to sound a reminder ‘beep’ for alarms and troubles, after the panel has been silenced. Refer to “System Setup” on page 100, for a detailed description of this feature. Pressing 1 while viewing System Setup Screen #1 will cause the display to toggle to *Trouble Rem On*, which enables this feature. Each press of the 1 key will cause the display to toggle between *Trouble Rem On* and *Trouble Rem Off*.

Banner

The top line of the display, which appears when the control panel is in normal mode, can be changed by using the Banner option. Pressing 2 while viewing System Setup Screen #1 will cause the following to be displayed:

BANNER
1=FACTORY
2=USER DEFINED

Banner Screen

```

BANNER
1=FACTORY
2=USER DEFINED

```

Banner Screen

Pressing *1* while viewing the Banner Screen will select the blank factory default banner setting and display the following screen:

```

FACTORY BANNER

```

Factory Banner Screen

Pressing the Enter key will store this selection in nonvolatile memory and return the display to the Banner Screen.

Pressing *2* while viewing the Banner Screen will display the following screens :

```

USER DEFINED BANNER
PRESS ENTER IF OK

```

User Defined Banner Screen #1

```

USER BANNER - LINE 2
PRESS ENTER IF OK
*****

```

User Defined Banner Screen #2

These screens allow the programmer to enter a two line custom banner. A flashing cursor will appear in the bottom left corner of each display. A maximum of 20 characters (including spaces) can be entered into each screen for a total of two lines with 40 characters. After entering up to 20 characters in the first screen, press *Enter* to view the second screen. Enter up to 20 characters in the second screen in the same manner or just press *Enter* if a second banner line is not being entered. To quickly clear the current banner, press the *CLR* key.

To enter alphanumeric characters from the keypad, repeatedly press the appropriate key until the desired character is displayed in the first position. For example, to enter the letter *B*, press the *2 (ABC)* key three times to toggle through the characters *A*, *B*, and *C*. Press the right arrow key to move the cursor one position to the right and repeat the process to enter the next character. To enter a space, press the ** (QZ)* key four times to place a blank in the desired position. When all characters have been entered, press *Enter* to store the information and return to the Banner Screen.

```

SYSTEM SETUP
1=TROUBLE REM
2=BANNER
3=TIME-DATE

```

System Setup Screen #1

Time-Date

The control panel time and date can be changed by pressing 3 while viewing the System Setup Screen #1. The following screen will be displayed:

```

TIME AND DATE
1=TIME 10:00 AM
2=DATE 02-04-2010
3=CLOCK FORMAT 12HR

```

Time-Date Screen #1

```

TIME AND DATE
1=DAYLIGHT SAVINGS

```

Time-Date Screen #2

■ Time

To change the time, press 1 while viewing the Time-Date Screen. The following screen will be displayed:

```

ENTER TIME
10:00 AM
1=AM          2=PM

```

Time Screen

A flashing cursor is located toward the top left of the display. Below the cursor is the current time. To change the time, enter the two-digit hours followed by the two-digit minutes. The cursor will move one position to the right each time a digit is entered. After the last minutes digit is entered, the cursor will again move one position to the right. At this point enter 1 for AM or 2 for PM. The display will then return to the Time-Date Screen which will show the new time entry. If an error is made while entering a digit, press the CLR key to delete the entire entry and beginning again.

■ Date

To change the date, press 2 while viewing the Time-Date Screen. The following screen will be displayed:

```

ENTER DATE
MONTH DAY YEAR
02-04-2010

```

Date Screen

A flashing cursor is located toward the top left of the display. Below the cursor is the current date. To change the date, enter the two-digit month followed by the two-digit day and then the two-digit year (09 for 2009, 10 for 2010, etc.). The cursor will move one position to the right each time a

digit is entered. After the last year digit is entered, the display will return to the Time-Date Screen which will show the new date entry. If an error is made while entering a digit, press the *CLR* key to delete the entire entry and beginning again.

■ Clock Format

The clock can be configured to display 12 hour (AM & PM) or 24 hour (military) time. Pressing 3 while viewing the Time-Date screen will cause the display to toggle between 12HR and 24HR. Select 12HR for 12 hour display or 24HR for 24 hour display.



NOTE: If the clock is changed to 24 hour (military) format, the date will change to the European standard of **Day-Month-Year** (for display purposes only).

TIME AND DATE
1=DAYLIGHT SAVINGS

Time & Date Screen #2

■ Daylight Savings Time

Pressing 1 while viewing Time-Date Screen #2 will cause the following screens to be displayed:

```

DAYLIGHT SAVINGS
1=ENABLED      YES
2=START MONTH  MAR
3=START WEEK   WEEK-2
  
```

Daylight Savings Screen #1

```

DAYLIGHT SAVINGS
1=END MONTH    NOV
2=END WEEK     WEEK-1
  
```

Daylight Savings Screen #2

Pressing 1 while viewing Daylight Savings Screen #1 will cause the display to toggle between *Enabled Yes* and *Enabled No*. The control panel will automatically update the time for daylight savings time when *Enabled Yes* is selected.

Pressing 2 while viewing Daylight Savings Screen #1 will display another screen which allows the programmer to select the month that daylight savings time will begin. In this sub-screen, pressing 1 will select March, 2 will select April, and 3 will select May.

Pressing 3 while viewing Daylight Savings Screen #1 will display two sub-screens which allow the programmer to select the week of the month that daylight savings time will begin. In the first sub-screen, pressing 1 will select the first week, 2 will select the second week, and 3 will select the third week, while in the second sub-screen, pressing 1 will select the fourth week and 2 will select the last week of the selected month.

Pressing 1 while viewing Daylight Savings Screen #2 will display another screen which allows the programmer to select the month that daylight savings time will end. In this sub-screen, pressing 1 will select September, 2 will select October, and 3 will select November.

Pressing 2 while viewing Daylight Savings Screen #2 will display two sub-screens which allow the programmer to select the week of the month that daylight savings time will end. In the first sub-screen, pressing 1 will select the first week, 2 will select the second week, and 3 will select the third week, while in the second sub-screen, pressing 4 will select the fourth week and 5 will select the last week of the selected month.

```

SYSTEM SETUP
1=TIMERS
2=NAC
3=RELAYS
    
```

System Setup Screen #2

Timers

Timer delays for PAS, Pre-signal and waterflow activation can be programmed by pressing *1* while viewing System Setup Screen #2. The following screen will be displayed:

```

          TIMERS
1=PAS DELAY      000
2=PRE SIGNAL    000
3=WATERFLOW     000
    
```

Timer Screen #1

```

          TIMERS
1=AC LOSS DELAY 000
    
```

Timer Screen #2

```

TIMERS
1=PAS DELAY 000
2=PRE SIGNAL 000
3=WATERFLOW 000
    
```

Timer Screen #1

■ PAS (Positive Alarm Sequence) Delay

The factory default setting for PAS is 000 for no delay. To select a PAS delay of 001 to 180 seconds for all devices programmed for PAS, press *1* while viewing Timer Screen #1. The following display will appear:

```

          PAS DELAY
RANGE 0-180 SECONDS
    
```

PAS Delay Screen

A flashing cursor is positioned in the lower left corner of the display. Enter a delay time consisting of three digits, such as 005 for five seconds. Upon entering the third digit, the time delay will be stored in the control panel memory and the display will return to the Delay Screen which will indicate the new delay time.

■ Pre-signal Delay

The factory default setting for Pre-signal delay is 000 for no delay. To select a Pre-signal delay of 001 to 180 seconds for all devices programmed for Pre-signal, press *2* while viewing Timer Screen #1. The following screen will be displayed:

```

          PRESIGNAL DELAY
RANGE 0-180 SECONDS
    
```

Pre-signal Delay Screen

A flashing cursor is positioned in the lower left corner of the display. Enter a delay time consisting of three digits, such as 009 for nine seconds. Upon entering the third digit, the time delay will be stored in the control panel memory and the display will return to the Delay Screen which will indicate the new delay time.

Note that the FACP can be programmed for either PAS or Pre-signal operation, not both. Refer to “Edit Detector” on page 69 for programming details.

```
TIMER
1=PAS DELAY 000
2=PRE SIGNAL 000
3=WATERFLOW 000
```

Timer Screen #1

■ Waterflow Delay

A delay can be added prior to declaring a waterflow type of alarm. Be careful to include any built-in delays of the waterflow device. The factory default setting for Waterflow delay is 000 for no delay. To select a Waterflow delay of 01 to 90 seconds for all devices programmed for Waterflow delay, press 3 while viewing Timer Screen #1. The following screen will be displayed:

```
WATERFLOW DELAY
RANGE 0-90 SECONDS
```

Waterflow Delay Screen

A flashing cursor is positioned in the lower left corner of the display. Enter a delay time consisting of two digits, such as 25 for twenty-five seconds. Upon entering the second digit, the time delay will be stored in the control panel memory and the display will return to the Delay Screen which will indicate the new delay time.

```
TIMER
1=AC LOSS DELAY
```

Timer Screen #2

■ AC Loss Delay

The reporting of a loss of AC power to a central station can be delayed by programming the length of the desired delay. The factory default setting is 2 hours. Press 1 while viewing Timer Screen #2 to display the following:

```
AC LOSS DELAY
1=NO DELAY
2=ENTER DELAY
```

AC Loss Delay Screen #1

Pressing 1 while viewing AC Loss Delay Screen #1 will program the FACP to transmit an AC Loss report immediately to the central station.

Pressing 2 while viewing AC Loss Delay Screen #1 will display the following screen:



AC Loss Delay Screen #2

A flashing cursor will appear in the lower left corner of the display. The factory default setting is 02 hours. Type the two digit AC loss reporting delay in hours (00 to 23 hour delay). When the second digit is entered, the display will return to AC Loss Delay Screen #1.

NAC (Notification Appliance Circuit)

The options for the NACs on the control panel main circuit board can be set by pressing 2 while viewing System Setup Screen #2. The following screens will be displayed:

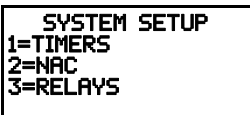

System Setup Screen #2

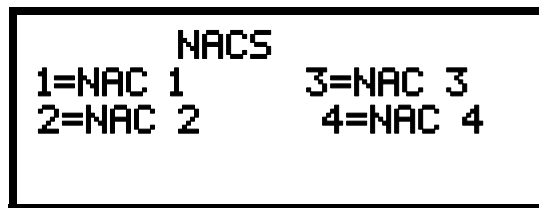

NAC Selection Screen

The Notification Appliance Circuits can be configured independently by pressing 1 for NAC 1, 2 for NAC 2, 3 for NAC 3, or 4 for NAC 4.

Note that 3=NAC 3 and 4=NAC 4 will only be displayed if the NACKEY NAC option card is installed, in JP8 of the main circuit board, for Class B operation.

The following screens will be displayed for either selection:

```

      NAC #
1=ENABLED      YES
2=TYPE         BELL
3=SILENCEABLE YES
  
```

NAC Screen #1

```

      NAC #
1=AUTO SILENCE 00
2=CODING
      TEMPORAL
  
```

NAC Screen #2

```

      NAC #
1=ZONE
   00 00 00 00 00
2=SIL INHIBITED NO
  
```

NAC Screen #3

```

      NAC #
1=SYNC TYPE    S
  
```

NAC Screen #4

■ Enabled

Pressing *I* while viewing NAC Screen #1 will cause the display to change to *Enabled No*. This will prevent the selected main circuit board NAC from activating its devices. Each press of the *I* key will cause the display to toggle between *Enabled Yes* and *Enabled No*.

NAC #
1=ENABLED
2=TYPE
3=SILENCEABLE

NAC Screen #1

■ Type

The main circuit board NAC type can be programmed by pressing 2 while viewing NAC Screen #1. The following screen will be displayed. Press the down arrow key to view additional screens:

NAC TYPE ↓

1=BELL
2=HORN
3=STROBE

Type Screen #1

Select the NAC device type by pressing the number corresponding to the type in the appropriate screen. When the selection is made, the display will return to NAC Screen #1.

The following table contains NAC type codes and their functions:

NAC Type Code	Special Function
Bell	None
Horn	None
Strobe	None
Synced Strobe	Synchronized to manufacturer
Strobe Sil Sync	Same as Synced Strobe but Silence turns off audible & visual devices
Future Use	None
Future Use	None
Future Use	None
Blank	None

■ Silenceable

Pressing 3 while viewing NAC Screen #1 will cause the display to change to *Silenceable No*. This will prevent the selected main circuit board NAC from being silenced by pressing the Alarm Silence key or by the Auto Silence feature. Each press of the 3 key will cause the display to toggle between *Silenceable Yes* and *Silenceable No*.

Important: When a Notification Appliance Circuit with a mix of audible and visual devices is programmed for silenceable and the **Synced Strobe** feature is selected, only the audible devices will be turned off if the Silence key is pressed. The visual devices (strobes, etc.) will continue to operate. If the **Strobe Sil Sync** feature is selected, Silence will turn off both audible and visual devices.

```

NAC #
1=AUTO SILENCE
2=CODING
    TEMPORAL
  
```

NAC Screen #2

■ Auto Silence

The Auto Silence feature, when enabled, automatically silences all main circuit board silenceable notification appliances after a programmed length of time. To enable this feature and program the time delay before Auto Silence activation, press *1* while viewing NAC Screen #2. The following screens will be displayed:

```

    AUTO SILENCE
    1=NO
    2=5 MINUTES
    3=10 MINUTES
  
```

Auto Silence Screen #1

```

    AUTO SILENCE
    1=15 MINUTES
    2=20 MINUTES
    3=25 MINUTES
  
```

Auto Silence Screen #2

```

    AUTO SILENCE
    1=30 MINUTES
  
```

Auto Silence Screen #3

To disable the Auto Silence feature, press *1* for *No* while viewing Auto Silence Screen #1. To enable the Auto Silence feature, press the number corresponding to the time delay which will elapse before Auto Silence activates. When a time delay is selected, the information will be stored in memory and the display will return to NAC Screen #2.

■ Coding

The Coding feature allows the programmer to select the type of output that the main circuit board notification appliances will generate when activated. Pressing *2* while viewing NAC Screen #2 will cause the following displays to appear:

```

    CODING
    1=STEADY
    2=MARCH TIME
    3=CALIFORNIA
  
```

Coding Screen #1

```

    CODING
    1=TEMPORAL
    2=TWO STAGE 3 MIN
    3=TWO STAGE 5 MIN
  
```

Coding Screen #2

The programmer can select the notification appliance output by pressing the number corresponding to the desired output. The coding selections are:

- Steady - a continuous output with no coding
- March Time - 120 ppm (pulse-per-minute) output
- California - 10 seconds on and 5 seconds off
- Temporal - ½ second on, ½ second off, ½ second on, ½ second off, ½ second on, 1½ second off
- Two Stage - refer to “Two Stage Operation” on page 111 for description

Selection of one of the above options will cause the control panel to store the information in memory and return the display to NAC Screen #2, which will display the new coding choice.

Two Stage Operation

Two Stage operation consists of the following:

- 1st stage output - 20 ppm (pulse-per-minute) coding
- 2nd stage output - Temporal coding as described above

If Two Stage operation is programmed as the Coding option, the following sequence of events will occur during an alarm.

1. The on-board NACs which are programmed to General Alarm Zone 0 will activate with a 1st stage output upon activation of any alarm point.
2. If the activated alarm point is directly mapped to a zone which is programmed to an on-board NAC, that NAC will go directly to 2nd stage coding output. All other NACs not directly mapped to the activated alarm point's zone but assigned to Zone 0 will activate with a 1st stage output.
3. If, after the programmed time of 3 or 5 minutes, the Acknowledge switch has not been pressed, all NACs presently in 1st stage activation will go to 2nd stage activation.
4. If an Acknowledge switch has been pressed, any NACs currently in 1st stage activation will remain in 1st stage. Pressing the Acknowledge switch does not affect NACs already in 2nd stage activation.
5. If another alarm point is activated and the countdown timer is counting, the alarm point will have no effect on the NACs unless the alarm point's zones are directly mapped to one of the NACs, in which case it will follow the procedure outlined in step 2.
6. If another alarm point is activated and the countdown timer has stopped counting due to the Acknowledge switch being pressed, the countdown timer will restart and the NACs will respond as outlined in step 2. NACs already in 2nd stage activation will not be affected.
7. Any control modules assigned to special Zone 99 will be activated either by direct mapping of an input device programmed to Zone 99 or if the timer counts down to zero and the NAC goes into 2nd stage coding.
8. Control modules that are programmed to the same zone as the activated input device will not be delayed for activation.

■ Zone

A maximum of five zones can be programmed to each main circuit board NAC. Pressing *1* while viewing NAC Screen #3 displays the following screen:

```

NAC #
1=ZONE
  00 00 00 00 00
2=SIL INHIBITED NO
  
```

NAC Screen #3

```

ZONE ASSIGNMENT
Z00 Z** Z** Z** Z**
  
```

Zone Screen

Note that Z** represents the Zone Number(s) corresponding to the selected NAC. The factory default for an unprogrammed device is Z00 for general alarm zone. A flashing cursor will appear on the first 0 to the left. Enter the two digit number corresponding to the zone that is to be assigned to this NAC. The cursor moves to the next Z** designation. Continue entering zone assignments or the remaining zones can be left blank or programmed as general alarm zone Z00. When all desired changes have been made, press the Enter key to store the zone assignments. The display will return to the NAC Screen #3 which will show the zone assignments just entered.

■ **Silence Inhibited**

The Silence Inhibit feature, when enabled, prevents the silencing of the selected main circuit board NAC for a period of one minute. Pressing 2 while viewing NAC Screen #3 will cause the display to change from the factory default of *Silence Inhibit No* to *Silence Inhibit Yes*. Each press of the 2 key will cause the display to toggle between the two options.

■ **Synced Type**

If synchronized strobes were selected as the Type of device installed, the type of synchronization must be selected in this option. Pressing 1 while viewing NAC Screen #4 will cause the following screen to be displayed:

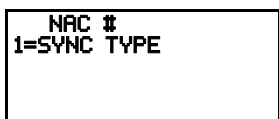

NAC Screen #4

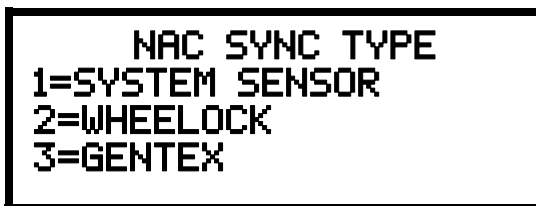

Pressing 1 while viewing this screen will select System Sensor synchronization, 2 will select Wheelock, and 3 will select Gentex.

Maximum Number of Strobes for Synchronization

The total current draw for each Notification Appliance Circuit cannot exceed 3.0 amps. Refer to the manufacturer’s documentation supplied with the Strobes to determine the maximum current draw for each strobe and ensure that the circuit maximum is not exceeded.

To ensure proper strobe and circuit operation, there is also a limit to the number of strobes that can be attached to each circuit. Following is a list of the strobes that have been tested with this FACP and the maximum number that can be connected to each NAC. Make sure that the NAC maximum current is not exceeded:

- System Sensor: 46 Strobes
- Wheelock: 42 Strobes
- Gentex: 39 Strobes

Relays

Pressing 3 while viewing System Setup Screen #2 allows the programmer to configure two of the main circuit board Form-C relays from the following screen:

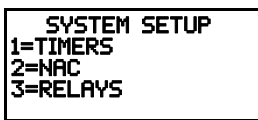

System Setup Screen #2

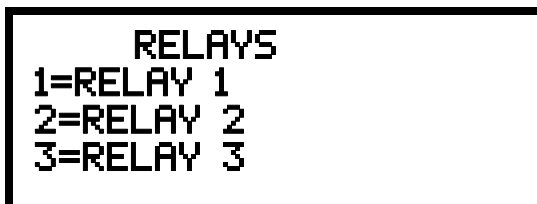

Relays Selection Screen

To program Relay 1 or Relay 3, press the number corresponding to the selected relay. Note that Relay 2 is fixed as a Trouble relay. Selecting Relay 2 will have no effect on its programming. The following screen will appear for each relay to be programmed:



Relay Type Screen

Pressing *1* for Type while viewing the Relay Screen will cause the following screens to be displayed:



Relay Screen #1



Relay Screen #2



Relay Screen #3



Relay Screen #4

While viewing the selected screen, press the number corresponding to the desired relay type to program the main circuit board relay. The choice will be stored in memory and the display will return to the Relay Type Screen which will show the programmed type choice. Press the *Escape* key to return to the Relays Selection Screen and repeat the preceding procedure for the remaining relays.

Note the following:

1. *AR (AutoResettable)* in *SUPERVISORY AR* and *PROCESS MON AR* means that a relay with the Supervisory and/or Process Monitor type code, when activated, will automatically reset when the corresponding condition is cleared.
2. A relay programmed with the Silenceable Alarm type will activate upon any alarm and deactivate when the FACP Alarm Silenced LED is illuminated.

Canadian Option

System Setup Screen #3

Pressing *1* while viewing System Setup Screen #3 will configure the FACP to comply with Canadian requirements. The display will change to *Canadian Opt. On*. Each press of the *1* key will cause the display to toggle between *Canadian Opt. On* and *Canadian Opt. Off*:

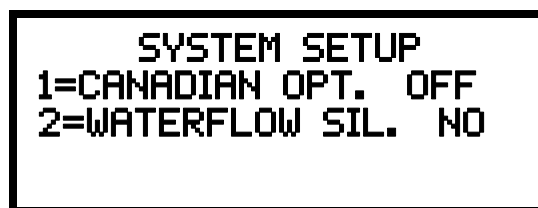

Important! For Canadian Applications, this option must be set to ON prior to any other panel programming.

The Canadian Options configures the FACP with the following as required by Canada:

- The following monitor module type codes are **not** available:
 - monitor
 - non-latching supervisory
 - non-latching drill
 - non-latching process monitor
 - process monitor
 - hazard
 - tornado
 - medical alert
- The auto-silence timer is fixed at 20 minutes and cannot be changed.
- Addressable ionization smoke detector sensitivity is automatically monitored using Canadian specifications.

Waterflow Silenceable

Pressing 2 while viewing System Setup Screen #3 will allow the programmer to configure the system for silenceable on nonsilenceable waterflow circuits. Each press of the 2 key will toggle the display between *Waterflow Sil. No* and *Waterflow Sil. Yes*. When *Waterflow Sil. No* is selected, all output devices associated with a waterflow type input device, will be nonsilenceable. When *Waterflow Sil. Yes* is selected, all output devices associated with a waterflow type input device, will be silenceable.

3.6.6 Verify Loops

```

PROGRAMMING
1=LOOP SETUP
2=SYSTEM SETUP
3=VERIFY LOOPS
  
```

Programming Screen #2

Pressing 3 while viewing Programming Screen #2, will select the Verify Loops option and display the following screen:

```

      VERIFY LOOPS
1=LOOP 1
2=LOOP 2
3=BOTH LOOPS
  
```

Verify Loop Select Screen

During loop verification, the FACP polls each device on the selected SLC to determine if the device is communicating and whether or not it responds with the proper type identification. The programmer can choose to verify one or both loops by pressing the number corresponding to the choices shown above.

When the selection is made, the following screen will be displayed while verification is in progress:

```

      VERIFYING LOOPS
      PLEASE WAIT
  
```

Verification Progress Screen

When Loop verification has been completed, the display will indicate that the system is OK or, if problems have been detected, any device type programming errors. Use the up and down arrow keys to view all detected errors.

3.6.7 History

```

PROGRAMMING
1=HISTORY
2=WALKTEST
3=OPTION MODULES

```

Programming Screen #3

The History option allows an authorized user to view or erase events which have occurred in the control panel. Pressing *I* while viewing Programming Screen #3 will display the History options as shown in the following display:

```

HISTORY
1=VIEW EVENTS
2=ERASE HISTORY

```

History Screen

View Events

```

HISTORY
1=VIEW EVENTS
2=ERASE HISTORY

```

History Screen

Pressing *I* while viewing the History Screen will allow the user to select the events to be viewed as illustrated in the following:

```

HISTORY
1=VIEW ALL
2=VIEW ALARMS
3=VIEW OTHER EVENTS

```

View Events Screen

While displaying the View Events screen, press *I* to view all events, *2* to view only alarms, or *3* to view other events. Use the up and down arrow keys to scroll through all of the displayed events.

Erase History

The Erase History option allows a user to erase all events from the history file. This will provide a clean slate in order to use the history file to track future events. Pressing *2* while viewing the History Screen will cause the following screen to be displayed:

```

ERASE HISTORY
PROCEED ?
1=YES          2=NO

```

Erase History Screen

Pressing *I* while viewing the Erase History Screen will erase all events from the History file. During this process, the display will read as follows:

```

ERASING HISTORY
PLEASE WAIT

```

Erase History Wait Screen

After the History file has been erased, the display will return to the History Screen.

3.6.8 Walktest

PROGRAMMING
1=HISTORY
2=WALKTEST
3=OPTION MODULES

Programming Screen #3

Walktest allows an individual to test the fire alarm system without the necessity to reset the control panel after each device activation. Pressing 2 while viewing the Programming Screen #3 will cause the following Walktest options to be displayed:

```

WALKTEST
1=SILENT
2=AUDIBLE
3=VIEW RESULT
  
```

Walktest Screen

To perform a silent walktest which will not sound the NACs, press 1 while viewing the Walktest Screen. To perform an audible walktest, which will sound the NACs, press 2 while viewing the Walktest Screen. When either option is chosen, the panel will enter Walktest Mode and the following screen will be displayed::

```

UNIT IN WALKTEST
1=VIEW WALKTEST LOG
2=VIEW POINTS
3=VIEW SUMMARY
  
```

Unit In Walktest Screen

From this screen, it is possible to view the walktest log, untested system points or a summary of the addressable devices tested during the current walktest. The user can select between any of these screens without interrupting the current walktest session. The walktest session will not end until the Unit In Walktest screen is exited by pressing the Escape key.

Pressing 1 for *View Walktest Log* while viewing the Unit In Walktest screen will cause a screen similar to one of the following two screens to be displayed:

```

NO EVENTS IN
WALKTEST LOG
  
```

OR

```

ALARM: MONITOR
NORTH CLASSROOM
                Z001
10*15A 020510 1M006
  
```

If there are no events in the current walktest session, the first screen will be displayed, indicating no events have been stored in the walktest log. If any events have been stored, a screen similar to the second will be displayed indicating the latest event. As walktest events occur, the display will change to indicate the latest event. All stored events can be scrolled on the screen by pressing the up or down arrow keys. To return to the first event, press the *1st Event* key.

Pressing 2 for *View Points* while viewing the Unit In Walktest screen will display one of the following screens:

```

NO POINTS IN
SYSTEM
  
```

OR

```

UNTESTED POINTS 010
10001 SMOKE (PHOTO)
*****
NOT TESTED
  
```

If the system has no points installed, the first screen will be displayed. If points are installed, the second screen will be displayed, which allows the viewing of all untested system points and their status relating to the current walktest session. The up and down arrow keys will allow viewing of all untested points. If a point is tested while it is being displayed, the screen will update and display the next untested point. The first line indicates the total number of untested points. The second line displays information about an untested point. A description on the bottom of the screen will indicate if the displayed point has been disabled, if the Walktest option has been disabled for that point or if the point is not yet tested. The up and down arrow keys allow the user to scroll through all untested points.

Pressing 3 for *View Summary* while viewing the Unit In Walktest screen will display a new screen which will show a total of the tested detectors, tested modules, untested detectors and untested modules for the current walktest session. If more than one SLC loop is installed on the FACP, pressing the down arrow key will display the Walktest summary for each SLC loop.

The user can perform a one-person walktest by activating devices throughout the system. As each device is activated, the information about the activated device is stored in the Walktest Log. The information can be viewed by choosing one of the options from the Unit In Walktest screen.

To end the Walktest session, press the Escape key to return to the Walktest screen. Pressing 3 for *View Results* while viewing the Walktest screen, after a walktest session has been completed, will allow the operator to view the final results of the most recent walktest. The following screen will be displayed:

```

WALKTEST RESULTS
  
```

View Result Screen

Use the up and down arrow keys to view all of the walktest results which will be displayed. Note that the Walktest log is stored in RAM. If all power (AC and DC) is removed from the FACP, the Walktest log information will be lost. This information is also overwritten when subsequent walktests are performed.

3.6.9 Option Modules

```

PROGRAMMING
1=HISTORY
2=WALKTEST
3=OPTION MODULES
  
```

Programming Screen #3

Options available for the FACP include ACS, Graphic, LED, Relay and LCD annunciators, printer connection for acquiring hardcopy printouts of panel data and PC (Personal Computer) connection for uploading and downloading panel data.

Pressing *3* while viewing Programming Screen #3 will display the following screen:

```

OPTION MODULES
1=ANNUNCIATORS/UDACT
2=ONBOARD DACT
3=PRINTER/PC PR4800
  
```

Options Screen

Note that *PR4800* in the display indicates that a supervised printer, configured for 4800 baud, has been previously programmed into the system.

Annunciators/UDACT

Pressing *1* while viewing the Options Screen will cause the control panel to display the following screens:

```

ANNUNCIATORS
1=TERM ENABLED NO
2=ACS OPTIONS
3=ANN-BUS OPTIONS
  
```

Annunciator Screen

A Terminal Mode annunciator, ACS Mode annunciator or ANN-BUS annunciator/module can be installed in the system. Do not use a mix of ACS annunciators and ANN annunciators since they use different communication protocols. ACS or ANN annunciators use the same TB6 terminal block connection. To install any of these devices, press the number corresponding to the desired device shown in the Annunciator Screen.

■ Term Options

While viewing the Annunciators Screen, each press of the *1* key for *Term Options*, will cause the display to toggle between *Term Enabled No* and *Term Enabled Yes*.



NOTE: The LCD-80F is a Terminal Mode annunciator. To enable the FACP for LCD-80F operation, press *1* for *Term Enabled Yes*.

■ ACS Options

```
ANNUNCIATORS
1=TERM OPTIONS
2=ACS OPTIONS
3=ANN-BUS OPTIONS
```

Annunciator Screen

Pressing 2 for *ACS Options* while viewing the Annunciators screen, will display the following screen:

```
ACS OPTIONS
1=ACS ENABLED      NO
2=ACS INSTALLED   NO
3=UDACT
```

Pressing 1 while viewing the ACS Options screen will cause the display to toggle between *ACS Enabled Yes* and *ACS Enabled No*. To install an ACS annunciator, the display must read *ACS Enabled Yes*.

If ACS has been enabled, press 2 while viewing the ACS Options screen to select addresses for the ACS annunciators. The following screen will be displayed:

```
ANNUNCIATOR
1=ADDRESS 1      YES
2=ADDRESS 2      NO
3=ADDRESS 3      NO
```

ACS Installed Screen

Pressing the down arrow key will allow the programmer to view additional screens displaying Addresses 1 -31. Each screen will indicate if an address has been used for an installed ACS annunciator. To select one or more addresses for the installed ACS annunciator(s), press the number key corresponding to the address in each screen. The display for the selected address will change from *No* to *Yes*. Each press of the number key will cause the display to toggle between *No* and *Yes*. The address of each installed annunciator must be enabled to allow communication between the FACP and annunciator.

Annunciator addressing is specific to the FACP control panel. The following table describes the annunciator addresses and the corresponding addressable devices that will be annunciated at each annunciator address.

ACS Annunciator Address	Annunciator Displays the Following Points
1	8 General System Status Points & Zones 1 - 56
2	Zones 57 - 99 & 4 NACs
3	Loop 1, Module Addresses 1 - 64
4	Loop 2, Module Addresses 1 - 64
5	Loop 1, Module Addresses 65 - 128
6	Loop 2, Module Addresses 65 - 128
7	Loop 1, Module Addresses 129 - 159 & Loop 2 Module Addresses 129 - 159
8	Loop 1, Detector Addresses 1 - 64
9	Loop 2, Detector Addresses 1 - 64
10	Loop 1, Detector Addresses 65 - 128
11	Loop 2, Detector Addresses 65 - 128
12	Loop 1 Detector Addresses 129 - 159 & Loop 2 Detector Addresses 129 - 159
13	not used
14	not used
15	not used
16	not used
17	not used
18	not used
19	not used
20	8 General System Status Points & Zones 1 - 56
21	Zones 57 - 99 & 4 NACs
22	Loop 1, Module Addresses 1 - 64
23	Loop 2, Module Addresses 1 - 64
24	Loop 1, Module Addresses 65 - 128
25	Loop 2, Module Addresses 65 - 128
26	Loop 1, Module Addresses 129 - 159 & Loop 2 Module Addresses 129 - 159
27	Loop 1, Detector Addresses 1 - 64
28	Loop 2, Detector Addresses 1 - 64
29	Loop 1, Detector Addresses 65 - 128
30	Loop 2, Detector Addresses 65 - 128
31	Loop 1 Detector Addresses 129 - 159 & Loop 2 Detector Addresses 129 - 159
32	not used

The 8 General System Status Points include the following:

- General Alarm
- General Trouble
- General Supervisory
- Alarm Silenced
- System Off Normal
- AC Loss
- Battery Fault
- NAC Fault

Pressing 3 while viewing the ACS Options screen will toggle the display between *UDACT NO* and *UDACT YES*. This allows the connection of an external UDACT (Universal Digital Alarm Communicator/Transmitter).

```

ANNUNCIATORS
1=TERM OPTIONS
2=ACS OPTIONS
3=ANN-BUS OPTIONS

```

Annunciator Screen

■ ANN-BUS Options

Pressing *3* for *ANN-BUS Options*, while viewing the Annunciators screen, will cause the following screens to be displayed:

```

ANN-BUS
1=ENABLED          NO
2=MODULES INSTALLED
3=AUTO-CONFIGURE

```

ANN-BUS Screen #1

```

ANN-BUS
1=ANN-S/PG OPTIONS
2=ANN-80 OPTIONS

```

ANN-BUS Screen #2

A printer module, graphic annunciator module, LCD annunciator module, LED annunciator module and relay module can be programmed into the system. These devices communicate with the FACP over the ANN-BUS terminals on the control panel.

ANN-BUS Enabled

The ANN-BUS must be enabled if any modules are connected to the ANN-BUS terminals. To enable the ANN-BUS, press *1* while viewing ANN-BUS screen #1 so that the display reads *Enabled Yes*. Each press of the *1* key will cause the display to toggle between *Enabled Yes* and *Enabled No*.

Modules Installed

If an ANN-BUS module is installed, press *2* while viewing ANN-BUS screen #1 to select ANN-BUS addresses for the module(s). The following screen will be displayed.

```

ANN-BUS MODULES
1=ADDR. 1    NONE
2=ADDR. 2    NONE
3=ADDR. 3    NONE

```

ANN-BUS Modules Screen #1

Pressing the down arrow key will allow the programmer to view additional screens displaying Addresses 1-8. To program an ANN-BUS module to a specific address, press the number key corresponding to the desired address in each screen. The following screen will be displayed for each address:

```

ANN-BUS MODULES
ANN-BUS ADDRESS #
1=TYPE          NONE

```

ANN-BUS Address Screen

Pressing *1* for *Type* will display the following screens:

```

ANN-BUS MODULE TYPE ↓
1=NOT INSTALLED
2=ANN-80 MODULE
3=ANN-I/O MODULE
  
```

Module Type Screen #1

```

ANN-BUS MODULE TYPE ↑↓
1=ANN-S/PG MODULE
2=ANN-LED MODULE
3=ANN-RLY MODULE
  
```

Module Type Screen #2

```

ANN-BUS MODULE TYPE ↑
1=ANN-AUDIO
  
```

Module Type Screen #3

Press the number corresponding to the module type that is installed with the selected address.



NOTE: If the module type selected is the *ANN-80*, *ANN-S/PG*, or *ANN-AUDIO* or if *Not Installed* is selected, the ANN-BUS Address Screen shown on the previous page will be displayed following the module selection. The options selected for each of these modules will be the same for all modules of the same type (refer to “ANN-S/PG (Print) Options” on page 132 and “ANN-80 Options” on page 133).

If ANN-I/O, ANN-LED or ANN-RLY is the selected module type, the following ANN-BUS Address Screen will be displayed:

```

ANN-BUS MODULES
ANN-BUS ADDRESS #
1=TYPE          ANN-I/O
2=MODULE OPTIONS
  
```

ANN-BUS Address Screen

Since the options for each of these module types can be individually set, pressing *2* for *Module Options*, while viewing the ANN-BUS Address Screen will display the available options as described below.

ANN-I/O Options

Pressing 2 for Module Options while viewing ANN-BUS Address Screen when the ANN-I/O option is selected will display the following screen:

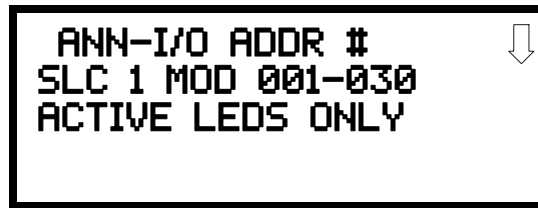

ANN-I/O Address Screen #1



ANN-I/O Address Screen #2

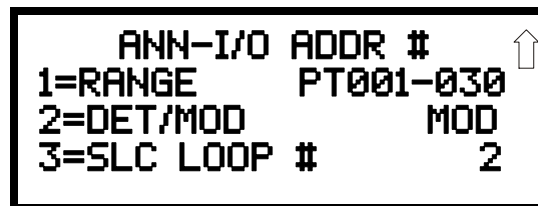

ANN-I/O Address Screen #3

The first screen indicates that the ANN-I/O at the selected ANN-BUS address is programmed to announce SLC Loop #1 addressable modules with addresses 1 through 30. The programming can be changed using ANN-I/O Address Screens 2 and 3.

Pressing 1 while viewing ANN-I/O Address Screen #2 will program the annunciator module to announce either Point (addressable device address) information or Zone information.

Pressing 1 while viewing ANN-I/O Address Screen #3 will select the Point or Zone range to be announced (refer to the tables in “ANN-I/O Zone Option” on page 123 and “ANN-I/O Point Option” on page 125).

Pressing 2 while viewing ANN-I/O Address Screen #3 will select either addressable detectors or addressable modules to be announced.

Pressing 3 while viewing ANN-I/O Address Screen #3 will select the SLC loop with the addressable devices to be announced.

ANN-I/O Zone Option

If *Zone* is selected as the module option, the first ten LEDs on the first ANN-I/O module will display the system status information. The remaining 30 LEDs on the first module and 40 LEDs on the remaining modules will display the active/alarm status of each zone in the Zone Range programmed for that particular module. The LED assignments for each ANN-I/O module will be as follows.

Module LED	ANN-I/O Module #1 Function	ANN-I/O Module #2 Function	ANN-I/O Module #3 Function
1	AC Fault	Zone 30	Zone 70
2	Fire Alarm	Zone 31	Zone 71
3	Supervisory	Zone 32	Zone 72

4	Trouble	Zone 33	Zone 73
5	Alarm Silenced	Zone 34	Zone 74
6	Earth Fault	Zone 35	Zone 75
7	Battery Fault	Zone 36	Zone 76
8	Charger Fault	Zone 37	Zone 77
9	NAC Fault	Zone 38	Zone 78
10	Disabled	Zone 39	Zone 79
11	Zone 00	Zone 40	Zone 80
12	Zone 01	Zone 41	Zone 81
13	Zone 02	Zone 42	Zone 82
14	Zone 03	Zone 43	Zone 83
15	Zone 04	Zone 44	Zone 84
16	Zone 05	Zone 45	Zone 85
17	Zone 06	Zone 46	Zone 86
18	Zone 07	Zone 47	Zone 87
19	Zone 08	Zone 48	Zone 88
20	Zone 09	Zone 49	Zone 89
21	Zone 10	Zone 50	Zone 90
22	Zone 11	Zone 51	Zone 91
23	Zone 12	Zone 52	Zone 92
24	Zone 13	Zone 53	Zone 93
25	Zone 14	Zone 54	Zone 94
26	Zone 15	Zone 55	Zone 95
27	Zone 16	Zone 56	Zone 96
28	Zone 17	Zone 57	Zone 97
29	Zone 18	Zone 58	Zone 98
30	Zone 19	Zone 59	Zone 99
31	Zone 20	Zone 60	Not Used
32	Zone 21	Zone 61	Not Used
33	Zone 22	Zone 62	Not Used
34	Zone 23	Zone 63	Not Used
35	Zone 24	Zone 64	Not Used
36	Zone 25	Zone 65	Not Used
37	Zone 26	Zone 66	Not Used
38	Zone 27	Zone 67	Not Used
39	Zone 28	Zone 68	Not Used
40	Zone 29	Zone 69	Not Used

ANN-I/O Point Option

If *Point* is selected as the module option, the first ten LEDs on the first ANN-I/O module will display the system status information. The remaining 30 LEDs on the first module and 40 LEDs on each additional module will display the active/alarm status of each point in the Point Range programmed for that particular module. The points that will be annunciated on a particular ANN-I/O module depend on the programming options selected as far as which SLC loop and the device type (detector or module) to be annunciated. The LED assignments for each ANN-I/O module will be as follows.

Module LED	ANN-I/O Module #1 Function	ANN-I/O Module #2 Function	ANN-I/O Module #3 Function	ANN-I/O Module #4 Function	ANN-I/O Module #5 Function
1	AC Fault	Point 31	Point 71	Point 111	Point 151
2	Fire Alarm	Point 32	Point 72	Point 112	Point 152
3	Supervisory	Point 33	Point 73	Point 113	Point 153
4	Trouble	Point 34	Point 74	Point 114	Point 154
5	Alarm Silenced	Point 35	Point 75	Point 115	Point 155
6	Earth Fault	Point 36	Point 76	Point 116	Point 156
7	Battery Fault	Point 37	Point 77	Point 117	Point 157
8	Charger Fault	Point 38	Point 78	Point 118	Point 158
9	NAC Fault	Point 39	Point 79	Point 119	Point 159
10	Disabled	Point 40	Point 80	Point 120	Not Used
11	Point 01	Point 41	Point 81	Point 121	Not Used
12	Point 02	Point 42	Point 82	Point 122	Not Used
13	Point 03	Point 43	Point 83	Point 123	Not Used
14	Point 04	Point 44	Point 84	Point 124	Not Used
15	Point 05	Point 45	Point 85	Point 125	Not Used
16	Point 06	Point 46	Point 86	Point 126	Not Used
17	Point 07	Point 47	Point 87	Point 127	Not Used
18	Point 08	Point 48	Point 88	Point 128	Not Used
19	Point 09	Point 49	Point 89	Point 129	Not Used
20	Point 10	Point 50	Point 90	Point 130	Not Used
21	Point 11	Point 51	Point 91	Point 131	Not Used
22	Point 12	Point 52	Point 92	Point 132	Not Used
23	Point 13	Point 53	Point 93	Point 133	Not Used
24	Point 14	Point 54	Point 94	Point 134	Not Used
25	Point 15	Point 55	Point 95	Point 135	Not Used
26	Point 16	Point 56	Point 96	Point 136	Not Used
27	Point 17	Point 57	Point 97	Point 137	Not Used
28	Point 18	Point 58	Point 98	Point 138	Not Used
29	Point 19	Point 59	Point 99	Point 139	Not Used
30	Point 20	Point 60	Point 100	Point 140	Not Used
31	Point 21	Point 61	Point 101	Point 141	Not Used
32	Point 22	Point 62	Point 102	Point 142	Not Used
33	Point 23	Point 63	Point 103	Point 143	Not Used
34	Point 24	Point 64	Point 104	Point 144	Not Used
35	Point 25	Point 65	Point 105	Point 145	Not Used
36	Point 26	Point 66	Point 106	Point 146	Not Used
37	Point 27	Point 67	Point 107	Point 147	Not Used
38	Point 28	Point 68	Point 108	Point 148	Not Used
39	Point 29	Point 69	Point 109	Point 149	Not Used
40	Point 30	Point 70	Point 110	Point 150	Not Used

ANN-LED Options

Pressing 2 for Module Options while viewing ANN-BUS Address Screen when the ANN-LED option is selected will display the following screen:

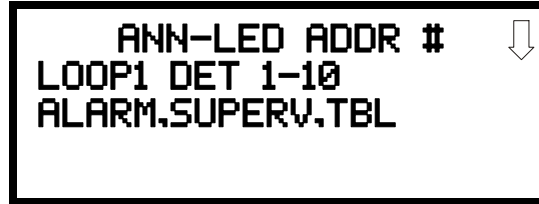

ANN-LED Address Screen #1

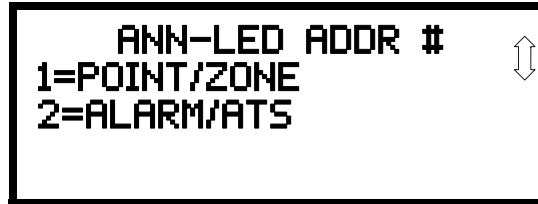

ANN-LED Address Screen #2

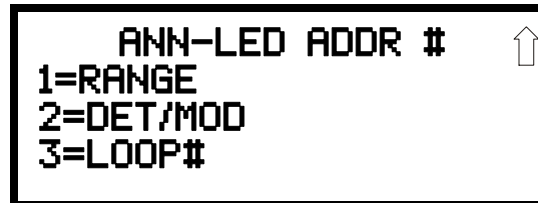

ANN-LED Address Screen #3

The first screen indicates that the ANN-LED at the selected ANN-BUS address is programmed to annunciate Alarms, Supervisories and Troubles for SLC Loop #1 addressable Detectors with addresses 1 through 10. The programming can be changed using ANN-LED Address Screens 2 and 3.

Pressing 1 while viewing ANN-LED Address Screen #2 will program the annunciator module to annunciate either Point (addressable device address) information or Zone information.

Pressing 2 while viewing ANN-LED Address Screen #2 will program the annunciator module to annunciate only Alarms for addressable device addresses 1-30 or Alarms, Supervisories and Troubles for addressable device addresses 1-10.

Pressing 1 while viewing ANN-LED Address Screen #3 will select the Point or Zone range to be annunciated (refer to the tables in “ANN-LED Zone Option - Alarm Only (for use with ANN-RLED module)” on page 127 and “ANN-LED Point Option - Alarm Only (for use with ANN-RLED module)” on page 129).

Pressing 2 while viewing ANN-LED Address Screen #3 will select either addressable detectors or addressable modules to be annunciated.

Pressing 3 while viewing ANN-LED Address Screen #3 will select the SLC loop with the addressable devices to be annunciated.

ANN-LED Zone Option - Alarm Only (for use with ANN-RLED module)

If *Zone* is selected as the module option, and the module is programmed to annunciate **alarms only**, the first ten LEDs on the first ANN-LED module will display the system status information. The remaining 30 LEDs on the first module and the last 30 LEDs on the remaining modules will display the active/alarm status of each zone in the Zone Range programmed for that particular module. The LED assignments for each ANN-LED module will be as follows.

Alarm Silenced	NAC 1 Fault	NAC 2 Fault	NAC 3 Fault	NAC 4 Fault
Earth Fault	Battery Fault	Charger Fault	Disabled	Maintenance
Zone 00 Active/Alarm	Zone 01 Active/Alarm	Zone 02 Active/Alarm	Zone 03 Active/Alarm	Zone 04 Active/Alarm
Zone 05 Active/Alarm	Zone 06 Active/Alarm	Zone 07 Active/Alarm	Zone 08 Active/Alarm	Zone 09 Active/Alarm
Zone 10 Active/Alarm	Zone 11 Active/Alarm	Zone 12 Active/Alarm	Zone 13 Active/Alarm	Zone 14 Active/Alarm
Zone 15 Active/Alarm	Zone 16 Active/Alarm	Zone 17 Active/Alarm	Zone 18 Active Alarm	Zone 19 Active/Alarm
Zone 20 Active/Alarm	Zone 21 Active/Alarm	Zone 22 Active/Alarm	Zone 23 Active/Alarm	Zone 24 Active/Alarm
Zone 25 Active/Alarm	Zone 26 Active/Alarm	Zone 27 Active/Alarm	Zone 28 Active/Alarm	Zone 29 Active/Alarm

ANN-RLED Module #1

Not Used	Not Used	Not Used	Not Used	Not Used
Not Used	Not Used	Not Used	Not Used	Not Used
Zone 30 Active/Alarm	Zone 31 Active/Alarm	Zone 32 Active/Alarm	Zone 33 Active/Alarm	Zone 34 Active/Alarm
Zone 35 Active/Alarm	Zone 36 Active/Alarm	Zone 37 Active/Alarm	Zone 38 Active/Alarm	Zone 39 Active/Alarm
Zone 40 Active/Alarm	Zone 41 Active/Alarm	Zone 42 Active/Alarm	Zone 43 Active/Alarm	Zone 44 Active/Alarm
Zone 45 Active/Alarm	Zone 46 Active/Alarm	Zone 47 Active/Alarm	Zone 48 Active Alarm	Zone 49 Active/Alarm
Zone 50 Active/Alarm	Zone 51 Active/Alarm	Zone 52 Active/Alarm	Zone 53 Active/Alarm	Zone 54 Active/Alarm
Zone 55 Active/Alarm	Zone 56 Active/Alarm	Zone 57 Active/Alarm	Zone 58 Active/Alarm	Zone 59 Active/Alarm

ANN-RLED Module #2

The LED assignments for the modules annunciating Zone Ranges 60 - 89 and 90 - 99, will follow the same pattern as the second ANN-RLED module.

ANN-LED Zone Option - Alarm, Trouble and Supervisory

If *Zone* is selected as the module option, and the module is programmed to annunciate **alarms, troubles and supervisories**, the first ten LEDs on the first ANN-LED module will display the system status information. The remaining 30 LEDs on the first module and the last 30 LEDs on the remaining modules will display the alarm, trouble and supervisory status for each of the ten zones in the Zone Range programmed for that particular module. The LED assignments for each ANN-LED module will be as follows.

Alarm Silenced	NAC 1 Fault	NAC 2 Fault	NAC 3 Fault	NAC 4 Fault
Earth Fault	Battery Fault	Charger Fault	Disabled	Maintenance
Zone 00 Active/Alarm	Zone 01 Active/Alarm	Zone 02 Active/Alarm	Zone 03 Active/Alarm	Zone 04 Active/Alarm
Zone 00 Trouble	Zone 01 Trouble	Zone 02 Trouble	Zone 03 Trouble	Zone 04 Trouble
Zone 00 Supervisory	Zone 01 Supervisory	Zone 02 Supervisory	Zone 13 Supervisory	Zone 04 Supervisory
Zone 05 Active/Alarm	Zone 06 Active/Alarm	Zone 07 Active/Alarm	Zone 08 Active Alarm	Zone 09 Active/Alarm
Zone 05 Trouble	Zone 06 Trouble	Zone 07 Trouble	Zone 08 Trouble	Zone 09 Trouble
Zone 05 Supervisory	Zone 06 Supervisory	Zone 07 Supervisory	Zone 08 Supervisory	Zone 09 Supervisory

ANN-LED Module #1

Not Used	Not Used	Not Used	Not Used	Not Used
Not Used	Not Used	Not Used	Not Used	Not Used
Zone 10 Active/Alarm	Zone 11 Active/Alarm	Zone 12 Active/Alarm	Zone 13 Active/Alarm	Zone 14 Active/Alarm
Zone 10 Trouble	Zone 11 Trouble	Zone 12 Trouble	Zone 13 Trouble	Zone 14 Trouble
Zone 10 Supervisory	Zone 11 Supervisory	Zone 12 Supervisory	Zone 13 Supervisory	Zone 14 Supervisory
Zone 15 Active/Alarm	Zone 16 Active/Alarm	Zone 17 Active/Alarm	Zone 18 Active/Alarm	Zone 19 Active/Alarm
Zone 15 Trouble	Zone 16 Trouble	Zone 17 Trouble	Zone 18 Trouble	Zone 19 Trouble
Zone 15 Supervisory	Zone 16 Supervisory	Zone 17 Supervisory	Zone 18 Supervisory	Zone 19 Supervisory

ANN-LED Module #2

The LED assignments for the modules annunciating Zone Ranges 20 - 29, 30 - 39, 40 - 49, 50 - 59, 60 - 69, 70 - 79, 80 - 89 and 90 - 99, will follow the same pattern as the second ANN-LED module.

ANN-LED Point Option - Alarm Only (for use with ANN-RLED module)

If *Point* is selected as the module option and the module is programmed to annunciate **alarms** only, the first ten LEDs on the first ANN-LED module will display the system status information. The remaining 30 LEDs on the first module and the last 30 LEDs on each additional module will display the active/alarm status of each point in the Point Range programmed for that particular module. The points that will be annunciated on a particular ANN-LED module depend on the programming options selected as far as which SLC loop and the device type (detector or module) to be annunciated. The LED assignments for each ANN-LED module will be as follows.

Alarm Silenced	NAC 1 Fault	NAC 2 Fault	NAC 3 Fault	NAC 4 Fault
Earth Fault	Battery Fault	Charger Fault	Disabled	Maintenance
Point 01 Active/Alarm	Point 02 Active/Alarm	Point 03 Active/Alarm	Point 04 Active/Alarm	Point 05 Active/Alarm
Point 06 Active/Alarm	Point 07 Active/Alarm	Point 08 Active/Alarm	Point 09 Active/Alarm	Point 10 Active/Alarm
Point 11 Active/Alarm	Point 12 Active/Alarm	Point 13 Active/Alarm	Point 14 Active/Alarm	Point 15 Active/Alarm
Point 16 Active/Alarm	Point 17 Active/Alarm	Point 18 Active/Alarm	Point 19 Active/Alarm	Point 20 Active/Alarm
Point 21 Active/Alarm	Point 22 Active/Alarm	Point 23 Active/Alarm	Point 24 Active/Alarm	Point 25 Active/Alarm
Point 26 Active/Alarm	Point 27 Active/Alarm	Point 28 Active/Alarm	Point 29 Active/Alarm	Point 30 Active/Alarm

ANN-RLED Module #1 (Point Range 01 - 30)

Not Used	Not Used	Not Used	Not Used	Not Used
Not Used	Not Used	Not Used	Not Used	Not Used
Point 31 Active/Alarm	Point 32 Active/Alarm	Point 33 Active/Alarm	Point 34 Active/Alarm	Point 35 Active/Alarm
Point 36 Active/Alarm	Point 37 Active/Alarm	Point 38 Active/Alarm	Point 39 Active/Alarm	Point 40 Active/Alarm
Point 41 Active/Alarm	Point 42 Active/Alarm	Point 43 Active/Alarm	Point 44 Active/Alarm	Point 45 Active/Alarm
Point 46 Active/Alarm	Point 47 Active/Alarm	Point 48 Active/Alarm	Point 49 Active/Alarm	Point 50 Active/Alarm
Point 51 Active/Alarm	Point 52 Active/Alarm	Point 53 Active/Alarm	Point 64 Active/Alarm	Point 55 Active/Alarm
Point 56 Active/Alarm	Point 57 Active/Alarm	Point 58 Active/Alarm	Point 59 Active/Alarm	Point 60 Active/Alarm

ANN-RLED Module #2 (Point Range 31 - 60)

The LED assignments for the modules annunciating Point Ranges 61 - 90, 91 - 120, 121 - 150, and 151 - 159, will follow the same pattern as the second ANN-RLED module.

ANN-LED Point Option - Alarm, Trouble and Supervisory

If *Point* is selected as the module option, and the module is programmed to annunciate **alarms, troubles and supervisories**, the first ten LEDs on the first ANN-LED module will display the system status information. The remaining 30 LEDs on the first module and the last 30 LEDs on the remaining modules will display the alarm, trouble and supervisory status for each of the ten zones in the Point Range programmed for that particular module. The LED assignments for each ANN-LED module will be as follows.

Alarm Silenced	NAC 1 Fault	NAC 2 Fault	NAC 3 Fault	NAC 4 Fault
Earth Fault	Battery Fault	Charger Fault	Disabled	Maintenance
Point 01 Active/Alarm	Point 02 Active/Alarm	Point 03 Active/Alarm	Point 04 Active/Alarm	Point 05 Active/Alarm
Point 01 Trouble	Point 02 Trouble	Point 03 Trouble	Point 04 Trouble	Point 05 Trouble
Point 01 Supervisory	Point 02 Supervisory	Point 03 Supervisory	Point 04 Supervisory	Point 05 Supervisory
Point 06 Active/Alarm	Point 07 Active/Alarm	Point 08 Active/Alarm	Point 09 Active/Alarm	Point 10 Active/Alarm
Point 06 Trouble	Point 07 Trouble	Point 08 Trouble	Point 09 Trouble	Point 10 Trouble
Point 06 Supervisory	Point 07 Supervisory	Point 08 Supervisory	Point 09 Supervisory	Point 10 Supervisory

ANN-LED Module #1 (Point Range 01 - 10)

Not Used	Not Used	Not Used	Not Used	Not Used
Not Used	Not Used	Not Used	Not Used	Not Used
Point 11 Active/Alarm	Point 12 Active/Alarm	Point 13 Active/Alarm	Point 14 Active/Alarm	Point 15 Active/Alarm
Point 11 Trouble	Point 12 Trouble	Point 13 Trouble	Point 14 Trouble	Point 15 Trouble
Point 11 Supervisory	Point 12 Supervisory	Point 13 Supervisory	Point 14 Supervisory	Point 15 Supervisory
Point 16 Active/Alarm	Point 17 Active/Alarm	Point 18 Active/Alarm	Point 19 Active/Alarm	Point 20 Active/Alarm
Point 16 Trouble	Point 17 Trouble	Point 18 Trouble	Point 19 Trouble	Point 20 Trouble
Point 16 Supervisory	Point 17 Supervisory	Point 18 Supervisory	Point 19 Supervisory	Point 20 Supervisory

ANN-LED Module #2 (Point Range 11 - 20)

The LED assignments for the modules annunciating Point Ranges 21 - 30, 31 - 40 and 41 - 50, 51 - 60, 61 - 70, 71 - 80, 81 - 90, 91 - 100, 101 - 110, 111, 120, 121 - 130, 131 - 140, 141 - 150 and 151 - 159, will follow the same pattern as the second ANN-LED Module.

ANN-RLY Options

Pressing 2 for Module Options while viewing ANN-BUS Address Screen when the ANN-RLY option is selected will cause the following screen to be displayed:

```

ANN-RLY - ADDR. #
1=RELAY 1      ZONE 00
2=RELAY 2      ZONE 01
3=RELAY 3      ZONE 02
  
```

ANN-RLY Options Screen

The ANN-RLY module provides ten Form-C relays which can be programmed for various functions. The initial screen displays Relays 1 through 3. Pressing the down arrow key will display the remaining relays for this module.

To program any of the ANN-RLY relays, while viewing the appropriate ANN-RLY Option screen, press the number key corresponding to the relay to be programmed. Following is a list of the available programming options for each relay:

- Alarm
- Supervisory
- Supervisory AR
- Trouble
- Comm Fail
- Process Mon
- Process Mon AR
- AC Loss
- Hazard
- Medical
- Silenceable Alarm
- Zone Active XX

Auto-Configure

```

ANN-BUS
1=ANN ENABLED
2=OPTIONS INSTALLED
3=AUTO-CONFIGURE
  
```

ANN-BUS Screen #1

The ANN-BUS Auto-Configure features allows the programmer to quickly bring all installed ANN-BUS modules online. The software will search for all ANN-BUS modules and automatically program the device type and address into the system. *The ANN-BUS must be enabled for the Auto-Configure feature to work.*

Pressing 3 while viewing ANN-BUS Screen #1 will begin the Auto-Configure process and cause the following screen to be displayed:

```

ANN-BUS
AUTO-CONGFIGURE
IN PROGRESS
PLEASE WAIT
  
```

Auto-Configure Screen

```
ANN-BUS
1=ANN-S/PG OPTIONS
2=ANN-80 OPTIONS
```

ANN-BUS Screen #2

ANN-S/PG (Print) Options

The Print option allows the programmer to configure the optional printer. Pressing 1 while viewing ANN-BUS screen #2 will display the following screens:

```
ANN-S/PG OPTIONS
1=PORT          PAR
2=PRINTER SUPV NO
3=OFFLINE TIMER 60
```

ANN-S/PG Options Screen #1

```
ANN-S/PG OPTIONS
1=BAUD RATE     N/A
2=DATA BITS     N/A
3=PARITY        N/A
```

ANN-S/PG Options Screen #2

```
ANN-S/PG OPTIONS
1=STOP BITS     N/A
```

ANN-S/PG Options Screen #3

Pressing 1 for Port while viewing ANN-S/PG Options screen #1 will allow the programmer to select between a Parallel and Serial Port for printer connection. Each press of the 1 key will cause the display to toggle between *Port PAR* (parallel) and *Port SER* (serial). It is important to note that the interface selected determines which options are available to the user.

If the Parallel Port option is selected, the user has the option to supervise the printer and select an offline timer for the supervision by pressing 2 for Printer Supervision while viewing Print Options screen #1. Each press of the 2 key will cause the display to toggle between *Printer Supv NO* for no supervision and *Printer Supv YES* for printer supervision. Note that this option is not selectable if the Serial Port option has been selected.

If the Parallel Port option is selected, the user has the ability to select an *Offline Timer* by pressing 3 while viewing Print Options screen #1. The resultant screen allows the programmer to program the *Offline Timer* for a delay of between 0 and 255 seconds before loss of printer supervision is reported as a trouble.

If the Serial Port option is selected, the *Printer Supv* and *Offline Timer* options will not be available. The Baud Rate, Data Bits, Parity and Stop Bits options are only available when the Serial Port option has been selected.

Pressing 1 for *Baud Rate* while viewing ANN-S/PG Options screen #2 will cause a screen to appear which allow the user to select a Baud Rate of 19200, 9600, or 2400.

Pressing 2 for *Data Bits* while viewing ANN-S/PG Options screen #2 will cause a screen to appear which allows the user to select 7 or 8 *Data Bits*.

Pressing 3 for *Parity* while viewing ANN-S/PG Options screen #2 will cause a screen to appear which allows the user to select between *No Parity*, *Even Parity*, or *Odd Parity*.

Pressing 1 for *Stop Bits* while viewing ANN-S/PG Options screen #3 will cause a screen to appear which allows the user to select between 1.0 or 2.0 *Stop Bits*.

ANN-80 Options

```
ANN-BUS
1=ANN-S/PG OPTIONS
2=ANN-80 OPTIONS
```

ANN-BUS Screen #2

Pressing 2 while viewing ANN-BUS screen #2 will display the following screen:

```
ANN-80 OPTIONS
1=PIEZO ENABLE
2=LOCK ENABLE
3=ACK BTN ENABLE
```

ANN-80 Options Screen #1

```
ANN-80 OPTIONS
1=SIL BTN ENABLE
2=RST BTN ENABLE
3=DRL BTN ENABLE
```

ANN-80 Options Screen #2

The *Piezo Enable* option allows the programmer to select whether the piezo sounder on any installed ANN-80 module will ever sound. Pressing 1 while viewing the ANN-80 Options Screen #1 causes the display to toggle between *Piezo Enable Yes* and *Piezo Enable No*.

The *Lock Enable* option allows the programmer to select whether or not any installed ANN-80 annunciator must be unlocked by its key before any annunciator key presses will function. Pressing 2 while viewing the ANN-80 Options Screen #1 causes the display to toggle between *Lock Enable Yes* (annunciator must be unlocked for keys to function) and *Lock Enable No* (lock position is ignored).

The Acknowledge Button Enable (*ACK BTN ENABLE*) option allows the programmer to select whether the Ack/Step button on any installed ANN-80 annunciator will function normally or always be ignored. Pressing 3 while viewing the ANN-80 Options Screen #1 causes the display to toggle between *Ack Btn Enable Yes* (Ack/Step button functions normally) and *Ack Btn Enable No* (Ack/Step button never functions).

The Silence Button Enable (*SIL BTN ENABLE*) option allows the programmer to select whether the Silence button on any installed ANN-80 annunciator will function normally or always be ignored. Pressing 1 while viewing the ANN-80 Options Screen #2 causes the display to toggle between *Sil Btn Enable Yes* (Silence button functions normally) and *Sil Btn Enable No* (Silence button never functions).

The Reset Button Enable (*RST BTN ENABLE*) option allows the programmer to select whether the Reset button on any installed ANN-80 annunciator will function normally or always be ignored. Pressing 2 while viewing the ANN-80 Options Screen #2 causes the display to toggle between *Rst Btn Enable Yes* (Reset button functions normally) and *Rst Btn Enable No* (Reset button never functions).

The Drill Button Enable (*DRL BTN ENABLE*) option allows the programmer to select whether the Drill button on any installed ANN-80 annunciator will function normally or always be ignored. Pressing 3 while viewing the ANN-80 Options Screen #2 causes the display to toggle between *Drl Btn Enable Yes* (Drill button functions normally) and *Drl Btn Enable No* (Drill button never functions).

```

OPTION MODULES
1=ANNUNCIATORS/UDACT
2=ON BOARD DACT
3=PRINTER/PC  NO

```

Option Module Screen

On Board DACT

The Onboard DACT (Digital Alarm Communicator/Transmitter) provides communication to a Central Station. Pressing 2 while viewing the Option Module Screen will allow programming of the Onboard DACT. Refer to the *DACT-UD2 Installation and Programming Manual Document #53037* for detailed information on installing and programming this option.

Printer/PC

A Printer or a PC can be connected to the control panel. Pressing 3 while viewing the Option Module Screen will cause the following screen to appear:

```

          PRINTER-PC
1=PRINTER NO SU  NO
2=PRINTER SU    YES
3=PC            NO

```

Printer-PC Screen

Pressing 1 while viewing the Printer-PC Screen will program the control panel for an unsupervised (*NO SU*) printer. The display will change to the Printer Baud Rate Screen as shown below.

Pressing 2 while viewing the Printer-PC Screen will program the control panel for a supervised (*SU*) printer. Printer supervision, when enabled, will typically detect the removal of the printer cable and will detect when the printer power has been turned off. Depending upon the brand of printer, other errors such as paper empty or printer off-line may be detected.

Enabling either printer option will cause the following screen to appear, which allows the programmer to select the baud rate for the printer communication:

```

          PRINTER BAUD RATE
1=2400 BAUD
2=4800 BAUD
3=9600 BAUD

```

Printer Baud Rate Screen

Pressing the number key corresponding to the desired baud rate (2 for 4800 Baud for example) will program the control panel for the selected baud rate and return the display to the Option Module Screen which will indicate *Printer/PC PR4800* for a supervised printer installed at 4800 baud rate.

Pressing 3 while viewing the Printer-PC Screen will program the control panel for a PC connection. The display will return to the Option Module Screen which will indicate *Printer/PC PC* for personal computer installed.

3.6.10 Password Change

PROGRAMMING
1=PASSWORD CHANGE
2=CLEAR PROGRAM
3=PROGRAM CHECK

Programming Screen #4

The factory set passwords, which have been programmed into the control panel, can be changed by selecting the Password Change option. Pressing *1* while viewing Programming Screen #4 will cause the following screen to be displayed:

```

PASSWORD CHANGE
1=MASTER
2=MAINTENANCE
3=REMOTE DOWNLOAD
  
```

Password Change Screen

Press *1* to change the Master Programming Level password, *2* to change the Maintenance Level password, or *3* to change the Remote Download password. *Note that the passwords will not be displayed on LCD annunciators.*

The following screen will appear when either change option is selected:

```

ENTER NEW FIVE DIGIT
PASSWORD
  
```

Enter Password Screen

A flashing cursor will appear in the center of the display. Enter a new five digit password (such as *10101* for the Master Level). After the fifth digit is entered, the following screen will be displayed:

```

VERIFY NEW
PASSWORD
  
```

Password Change Screen

Re-enter the new password to accept the change. The display will return to the initial Password Change Screen.

3.6.11 Clear Program

PROGRAMMING
1=PASSWORD CHANGE
2=CLEAR PROGRAM
3=PROGRAM CHECK

Programming Screen #4

Pressing 2 while viewing Programming Screen #4, will select the Clear Program option. This will cause the LCD to display the following screens:

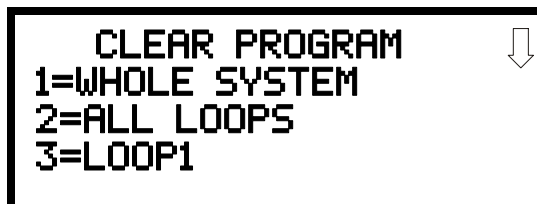

Clear Program Screen #1



Clear Program Screen #2

Pressing 1, for Whole System while viewing the Clear Program Screen #1, will clear all general system programming options and all programmed addressable devices from the nonvolatile memory of the FACP. *This function is useful when the control panel is first installed, prior to autoprogramming. Note that it is necessary to autoprogram after using the Clear Whole System function.*

Pressing 2, for All Loops while viewing the Clear Program Screen #1, will clear all programming related to all SLC loops and connected addressable devices.

Pressing 3, for Loop 1 while viewing the Clear Program Screen #1, will clear only the programming related to SLC Loop 1 and the connected addressable devices.

Pressing 1, for Loop 2 while viewing the Clear Program Screen #2, will clear only the programming related to SLC Loop 2 and the connected addressable devices.

Before executing any of the Clear commands listed above, the control panel will provide a warning to the user by prompting with the following display:

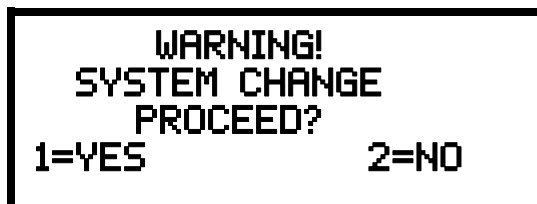

Pressing 1 will cause the control panel to carry out the selected clear option. Pressing 2 will prevent programming from being cleared.

3.6.12 Program Check

PROGRAMMING
1=PASSWORD CHANGE
2=CLEAR PROGRAM
3=PROGRAM CHECK

Programming Screen #4

The Program Check feature allows the programmer to view the zones which have been programmed to the Notification Appliance Circuits on the control panel but have not been programmed to Initiating Devices as well as other circuits with no input or output correlations. Pressing 3 while viewing Programming Screen #4 will cause the following screen to be displayed:

```
PROGRAM CHECK
1=NACS NO INPUT
2=ZONES NO INPUT
3=ZONES NO OUTPUT
```

PROGRAM CHECK
1=NACS NO INPUT
2=ZONES NO INPUT
3=ZONES NO OUTPUT

Program Check Screen

Pressing 1 while viewing the Program Check screen will display an NAC screen similar to the following.

```
NACS NO INPUT
NAC 1
  25 31 44 55 67
```

The example above indicates that NAC 1 has been programmed to Zones 25, 31, 44, 55 and 67 but no input devices have been programmed to any of these zones. Use the up and down arrow keys to view all the NAC zones without input assignments for NAC 1, NAC 2, NAC 3, and NAC 4.



NOTE: If the NACs have been configured for Class A in the setup option, only NAC1 and NAC2 will display test information. NAC3 and NAC4 will display asterisks (*) and will not be included in the test.

Pressing 2 while viewing the Program Check screen will display a screen similar to the following:

```
ZONES NO INPUT
05 07 09 10 11 1M001
```

The Zone No Input screen allows the programmer to view the zones which have not been programmed to at least one input device (not including general alarm Zone 00). The example in the preceding screen indicates that Zones 05, 07, 09, 10, and 11 have been programmed to an addressable module (control module in this example) with an address of 001 on loop 1 but have not been programmed to any input devices. Use the up and down arrow keys to view all the zones without input assignments.

Pressing 3 while viewing Program Check screen will cause a screen similar to the following to be displayed:

```
ZONES NO OUTPUT
05 07 09 10 11 1D001
```

The Zone No Output feature allows the programmer to view the zones which have not been programmed to at least one output device (not including general alarm Zone 00). The example in the preceding screen indicates that Zones 05, 07, 09, 10, and 11 have been programmed to an addressable detector with an address of 001 on loop 1 but have not been programmed to any output devices. Use the up and down arrow keys to view all the zones without output assignments.

3.7 Maintenance Programming Level

To access Maintenance Programming mode, press the *Enter* key. The LCD will display the following:

```
1=READ STATUS
2=PROGRAMMING
3=REMOTE DOWNLOAD
```

To enter the Maintenance Programming mode, press 2. The display will read as follows:

```
PROGRAMMING
ENTER PASSWORD
```

When the Maintenance level password (default *11111*) is entered, the following screen will appear:

```
PROGRAMMING
1=POINT PROGRAM
2=HISTORY
3=PROGRAM CHECK
```

Note that in the preceding screens, an arrow appears to inform the programmer that additional options can be viewed by pressing the keypad *down* arrow key, as shown in the following screen.



3.7.1 Disable Point

Pressing *1* for Point Program, while viewing Maintenance Screen #1 will cause the following screens to be displayed:



Maintenance Screen #1



Loop Select Screen

Select the Loop, containing the device to be disabled, by pressing *1* for Loop 1 or *2* for Loop 2. A screen will then be displayed, allowing the operator to select the type of addressable device to be disabled as shown in the following display:



Device Select Screen

Select the device type by pressing *1* for an addressable detector or *2* for an addressable module. The operator will be prompted to enter the three digit device address as shown in the following example for a detector:



Address Select Screen

A flashing cursor will appear in the bottom left corner of the display, prompting for the three digit device address. When the third digit is enter, *001* for example, a screen will appear which will allow enabling or disabling of the selected point, as illustrated in the following example:

```

EDIT DETECTOR 10001
1=ENABLED      YES
  
```

Enable/Disable Select Screen

Pressing *1* repeatedly will cause the display to toggle between *Enabled Yes* and *Enabled No*.

3.7.2 History

```

PROGRAMMING
1=POINT PROGRAM
2=HISTORY
3=PROGRAM CHECK
  
```

Maintenance Screen #1

Pressing *2* while viewing Maintenance Screen #1 will cause the following screen to be displayed:

```

HISTORY
1=VIEW EVENTS
2=ERASE HISTORY
  
```

History Screen

The History feature allows the operator to view control panel events which have been stored in a history file in memory and erase the contents of the history file

Pressing *1* while viewing the History screen will cause the following screen to be displayed:

```

HISTORY
1=VIEW ALL
2=VIEW ALARMS
3=VIEW OTHER EVENTS
  
```

Events Screen

To view all the events which have occurred in the control panel since the history file was last erased, press *1* while viewing the Events screen. To view only alarms which have occurred, press *2* while viewing the Events screen. To view events other than alarms, press *3*. The most recent event will be displayed on the screen. To view all of the selected events, press the up or down arrow keys to scroll through the list of events. If no events have occurred, the display will read *NO EVENTS IN HISTORY*.

Pressing 2 while viewing the History Screen will cause the following screen to be displayed:

```

ERASE HISTORY
PROCEED ?
1=YES          2=NO
  
```

Erase History Screen

Pressing 1 while viewing the Erase History Screen will cause the message *ERASING HISTORY, PLEASE WAIT* to be displayed. The display will then return to the History Screen. Pressing 2 will cause the display to return to the History Screen without erasing the History file.

3.7.3 Program Check

```

PROGRAMMING
1=POINT PROGRAM
2=HISTORY
3=PROGRAM CHECK
  
```

Maintenance Screen #1

Pressing 3 while viewing Maintenance Screen #1 will cause the following screen to be displayed:

```

PROGRAM CHECK
1=NACS NO INPUT
2=ZONES NO INPUT
3=ZONES NO OUTPUT
  
```

Program Check Screen

The Program Check feature allows the programmer to view the zones which have been programmed to the Notification Appliance Circuits on the control panel but have not been programmed to Initiating Devices as well as other circuits with no input or output correlations. Pressing 1 while viewing Program Check screen will cause a screen similar to the following to be displayed.

```

NACS NO INPUT
NAC 1
25 31 44 55 67
  
```

The example above indicates that NAC 1 has been programmed to Zones 25, 31, 44, 55, and 67 but no input devices have been programmed to any of these zones. Use the up and down arrow keys to view all the NAC zones without input assignments for NAC1, NAC2, NAC3, and NAC4.



NOTE: If the NACs have been configured for Class A in the Setup option, only NAC1 and NAC2 will display test information. NAC3 and NAC4 will display asterisks (*) and will not be included in the test.

Pressing 2 while viewing the Program Check screen will display a screen similar to the following:

```

ZONES NO INPUT
05 07 09 10 11 1M001
  
```

The Zone No Input screen allows the programmer to view the zones which have not been programmed to at least one input device (not including general alarm Zone 00). The example in the preceding screen indicates that Zones 05, 07, 09, 10, and 11 have been programmed to an addressable module (control module in this example) with an address of 001 on loop 1 but have not been programmed to any input devices. Use the up and down arrow keys to view all the zones without input assignments.

Pressing 3 while viewing Program Check screen will cause a screen similar to the following to be displayed:

```

ZONES NO OUTPUT
05 07 09 10 11 1O001
  
```

The Zone No Output feature allows the programmer to view the zones which have not been programmed to at least one output device (not including general alarm Zone 00). The example in the preceding screen indicates that Zones 05, 07, 09, 10, and 11 have been programmed to an addressable detector with an address of 001 on loop 1 but have not been programmed to any output devices. Use the up and down arrow keys to view all the zones without output assignments.

3.7.4 Walktest

```

PROGRAMMING
1=WALKTEST
2=SYSTEM
3=ZONE SETUP
  
```

Maintenance Screen #2

To perform a walktest, press 1 while viewing Maintenance Screen #2. The following screen will be displayed:

```

WALKTEST
1=SILENT
2=AUDIBLE
3=VIEW RESULT
  
```

Walktest Screen

The operator can press 1 to perform a silent walktest or 2 to perform an audible walktest. The display will read *UNIT IN WALKTEST*. To end the Walktest, press the *Esc* (Escape) key.

Pressing 3 after the walktest has been completed, will allow the operator to view the results of the walktest.

3.7.5 System

To program the time and date into the control panel, press 2 while viewing Maintenance Screen #2. The following display will appear:

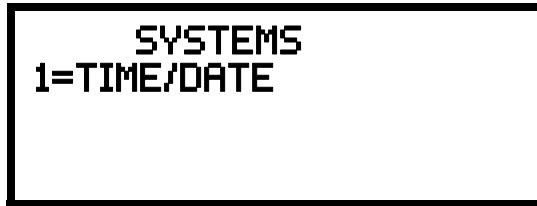

System Screen

Pressing 1 while viewing the System Screen will cause the following screen to be displayed:



Time and Date Screen

To change the time, press 1 to display the following screen:



Time Screen

A flashing cursor will appear on the left side of the display. Enter the four digit number corresponding to the time (0000 - 1259). When the fourth digit is entered, the cursor will move one position to the right. Press 1 for AM or 2 for PM to complete entering the time. The display will return to the Time and Date Screen displaying the new time.

To change the date, press 2 while viewing the Time and Date Screen. The following screen will be displayed:

ENTER DATE

█

MONTH DAY YEAR

01-01-2010

Date Screen

A flashing cursor will appear on the left side of the display. Enter the two digit month, two digit day and four digit year. The cursor will move one position to the right after each entry. When the fourth digit of the year has been entered, the display will return to the Time and Date Screen which will show the new date.

3.7.6 Zone Setup

PROGRAMMING

1=WALKTEST

2=SYSTEM

3=ZONE SETUP

Maintenance Screen #2

Pressing 3 while viewing Maintenance Screen #2 will display the following screen:

ZONE SETUP 

1=ENABLE

2=DISABLE

3=ZONE 97 98 99

Zone Setup Screen #1

ZONE SETUP 

1=ZONES INSTALLED

2=ZONES ENABLED

3=ZONES DISABLED

Zone Setup Screen #2

ZONE SETUP 

1=ZONE TYPES

2=ZONES AVAILABLE

3=ZONE MESSAGE

Zone Setup Screen #3

Pressing 1 while viewing Zone Setup screen #1 will display the following screen:

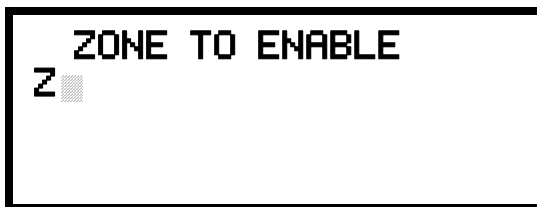

Enable Screen

A flashing cursor appears to the right of the Z. To enable a zone, enter the two digit zone number (00 - 99). After the second digit is entered, the zone will be enabled and the cursor will return to the original position. The next zone to be enabled can then be entered. Press *Esc* (Escape) to return to the previous screen.



Zone Setup Screen #2

Pressing 2 while viewing Zone Setup screen #1 will display the following screen:



Disable Screen

A flashing cursor appears to the right of the Z. To disable a zone, enter the two digit zone number (00 - 99). After the second digit is entered, the zone will be disabled and the cursor will return to the original position. The next zone to be disabled can then be entered. Press *Esc* (Escape) to return to the previous screen.

Pressing 3 while viewing Zone Setup screen #1 will display the following screen:

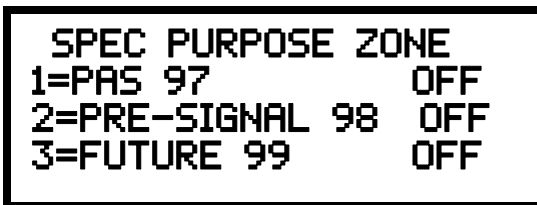

Disable Screen

Zones 97, 98, and 99 can be programmed for normal zone operation or for special purpose applications. In the above illustration, the three zones are shown Off, which means they can be programmed to function in the same manner as all other zones, by assigning them to input and output devices in the Programming Zone Assignment Screen.

Pressing 1 will cause the display to change to *PAS 97 On*. Each press of the 1 key will cause the display to toggle between *PAS 97 On* and *PAS 97 Off*. When Zone 97 is programmed On, a PAS (Positive Alarm Sequence) activation of any detector will cause Zone 97 to activate. By assigning Zone 97 to a control module in the Programming Zone Assignment Screen, an output device con-

nected to the control module can be used to indicate a PAS condition in the control panel. *Do not assign Zone 97 to a Notification Appliance Circuit when using this zone to indicate a PAS condition.*

Pressing 2 will cause the display to change to *Pre-signal 98 On*. Each press of the 2 key will cause the display to toggle between *Pre-signal 98 On* and *Pre-signal 98 Off*. When Zone 98 is programmed On, a Pre-signal activation of any device will cause Zone 98 to activate. By assigning Zone 98 to a control module in the Programming Zone Assignment Screen, an output device connected to the control module can be used to indicate a Pre-signal condition in the control panel. *Do not assign Zone 98 to a Notification Appliance Circuit when using this zone to indicate a Pre-signal condition.*

Zone 99, in special purpose mode, is reserved for future use and has no effect.

Zones Installed

Pressing 1 for Zones Installed, while viewing Zone Setup Screen #2, will display a screen similar to the following:

ZONE SETUP
1=ZONES INSTALLED
2=ZONES ENABLED
3=ZONES DISABLED

Zone Setup Screen #2

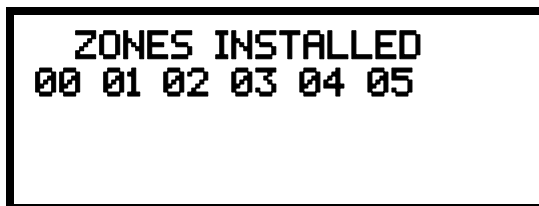

Zones Installed Screen

This display will show all of the zones that have been programmed into the control panel. Note that an up and/or down arrow may appear in the upper right corner of the display, indicating that additional screens of zone information exists. Press the up or down arrow keys to view the additional zones.

Zones Enabled

Pressing 2 for Zones Enabled, while viewing Zone Setup Screen #2, will display a screen similar to the following:

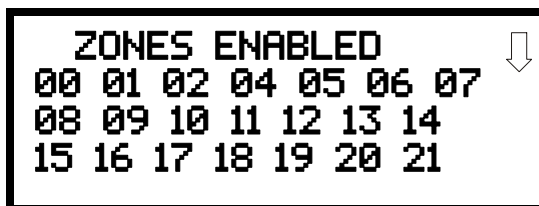

Zones Enabled Screen

This display will show all of the zones that are enabled in the control panel. Note that an up and/or down arrow may appear in the upper right corner of the display, indicating that additional screens of zone information exists. Press the up or down arrow keys to view the additional zones.

Zones Disabled

Pressing 3 for Zones Disabled, while viewing Zone Setup Screen #2, will display a screen similar to the following:



Zones Disabled Screen

This display will show all of the zones that are disabled in the control panel. Note that an up and/or down arrow may appear in the upper right corner of the display, indicating that additional screens of zone information exists. Press the up or down arrow keys to view the additional zones.



Zone Setup Screen #3

Zone Type

Zone Types must be programmed only if a DACT, programmed for zone reporting, is installed on the control panel. Pressing 1 for Zone Types, while viewing Zone Setup Screen #3, will display a screen similar to the following:



Zones Installed Screen

This display will show the system zones (default and user programmed) and their associated types. Note that an up and/or down arrow will appear in the upper right corner of the display, indicating that additional screens of zone information exists. Press the up or down arrow keys to view zones Z00 through Z99.

Zone types can be changed by pressing the keypad number key corresponding to the zone in each Zones Installed Screen. Available zone types will be displayed in the resultant screens. For example, to change the zone type for zone Z02 in the screen illustrated above, press 3. The following screens will be displayed:



Zone Type Program Screen #1



Zone Type Program Screen #2

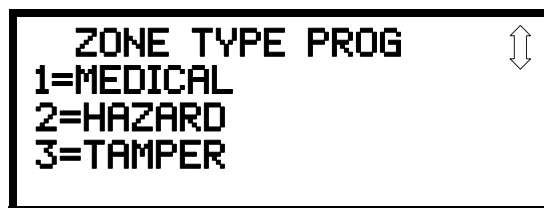

Zone Type Program Screen #3

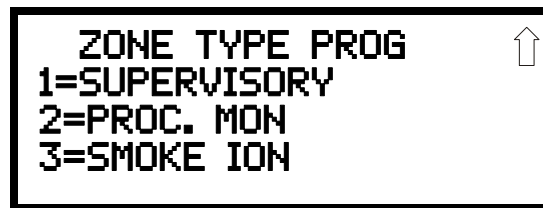

Zone Type Program Screen #4

To change the zone type for Z02 to Pull Station, scroll the display until Zone Type Program Screen #2 is displayed. Press 2 to program zone Z02 as a Pull Station zone. The display will return to the Zones Installed Screen showing zone Z02 and the Pull Station program type. Repeat the procedure for each zone to be changed.

IMPORTANT! In Zone Type Program Screen #1, selecting WATERFLOW will assign a Waterflow silenceable zone type to the selected zone. Any signaling devices programmed to the same zone can be silenced by pressing the Alarm Silence key or by using the auto-silence feature.

To program a waterflow circuit as nonsilenceable, refer to “System Setup” on page 100.



NOTE: Zone Types are only relevant for Central Station reporting. Changing a zone type will *only* change how it is reported to the Central Station.

Zones Available

Pressing 2 while viewing Zone Setup Screen #3 will display the following screen:

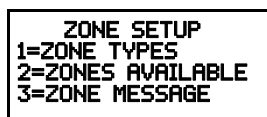

Zone Setup Screen #3

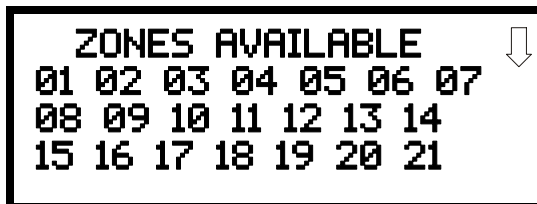

The display will show all of the zones that are still available for programming. Note that an up and/or down arrow may appear in the upper right corner of the display, indicating that additional screens of zone information exists. Press the up or down arrow key to view additional screens.

Zone Message

Pressing 3 while viewing Zone Setup Screen #3 will display the following screen:



Pressing the down arrow key will display additional screens for Zones up to Z99. Press the number key corresponding to the Zone to be programmed. Screens will be displayed allowing the programmer to select Messages 1 through 5. When a message is selected, the display will return to the Zone Message screen, showing the message selected for that particular zone. In the example above, Zone 01 has been programmed for Message 1.

Section 4: Operating Instructions

4.1 Panel Control Buttons

4.1.1 Acknowledge/Step

The first press of the *Acknowledge/Step* key silences the piezo sounder, changes flashing LEDs to steady and also changes the status field on the LCD display from capital letters to small letters. When the piezo is silenced, an *acknowledge* message is sent to the printer and the history file. *Acknowledge* also sends a *silence piezo* command to the optional annunciators connected to the FACP.

When more than one event exists, the first press of the Acknowledge/Step key functions as described in the preceding paragraph. Subsequent pressing of the key *steps* through each off-normal active event, with alarm events having a higher priority than trouble and supervisory events.

4.1.2 Alarm Silence

The *Alarm Silence* key performs the same functions as Acknowledge/Step. In addition, if an alarm exists, it turns off all silenceable NACs (Notification Appliance Circuits) and causes the Alarm Silenced LED to turn on. It also sends an 'alarm silenced' message to the printer, history file and optional annunciators. A subsequent new alarm will resound the system NACs. *Note that the Alarm Silenced LED is turned off by pressing the Reset key, the Drill key or subsequent activation of the NACs.*

4.1.3 Drill/Hold 2 Sec

When the *Drill* key is held for a minimum of two seconds (time required to prevent accidental activations), the FACP turns on all main panel NAC outputs and all silenceable circuits such as control modules that are programmed as silenceable, and turns off the Alarm Silenced LED if it was previously on. The *EVAC IN SYSTEM* message is shown on the LCD display. The same message is sent to the printer and history file. The *Alarm Silence* key can be used to turn off all silenceable NAC outputs following activation by the *Drill* key.

4.1.4 Reset

Pressing and releasing the *Reset* key turns off all control modules and NACs, temporarily turns off resettable power to 4-wire detectors, causes a *RESET IN SYSTEM* message to be displayed on the LCD and sends the same message to the printer and history file. It also performs a lamp test by turning on all LEDs (except the Ground LED), piezo sounder and LCD display segments after the *Reset* key is released. Any alarm or trouble that exists after a reset will resound the system.

4.2 LED Indicators

The nine LED indicators, which are located on the front panel, operate as follows:

AC Power

This is a green LED which illuminates if AC power is applied to the FACP. A loss of AC power will turn off this LED

Fire Alarm

This red LED flashes when one or more alarms occur. It illuminates steady when the *Acknowledge/Step* or *Alarm Silence* key is pressed. The Fire Alarm LED turns off when the *Reset* key is pressed. The LED will remain off if all alarms have been cleared.

Supervisory

This is a yellow LED that flashes when one or more supervisory conditions occur, such as a sprinkler valve tamper condition. It illuminates steady when the *Acknowledge/Step* or *Alarm Silence* key is pressed. It turns off when the *Reset* key is pressed and remains off if all supervisory alarms have been cleared.

Trouble

This is a yellow LED that flashes when one or more trouble conditions occur. It stays on steady when the *Acknowledge/Step* or *Alarm Silence* key is pressed. The LED turns off when all trouble conditions are cleared. This LED will also illuminate if the microprocessor watchdog circuit is activated.

Maintenance

This is a yellow LED that flashes to indicate that a smoke detector requires cleaning or replacement due to an invalid chamber reading or excessive drift.

Alarm Silenced

This is a yellow LED that turns on after the *Alarm Silence* key is pressed while an alarm condition exists. It turns off when the *Drill* or *Reset* key is pressed.

Disabled

This is a yellow LED that flashes to indicate that a zone, NAC, detector or module has been temporarily disabled in programming by the user.

Battery

This is a yellow LED that flashes to indicate a low battery voltage condition.

Ground

This is a yellow LED that turns on steady to indicate a ground fault condition (zero impedance between FACP and ground).

4.3 Normal Operation

With no alarms or troubles in the system, the display message is *System All Normal* along with the current time and date as shown below. To set the time and date, refer to the appropriate section in this manual.



The FACP performs the following functions at regular intervals while in Normal mode:

- Monitors AC input voltage and battery voltage
- Monitors and reports status of SLC loop(s), option cards and control panel
- Polls all devices on the SLC loop(s) and flashes each device LED while checking for valid replies, alarms, troubles, etc.
- Refreshes LCD display and updates time
- Scans control panel keypad for key presses
- Performs autotest for all SLC devices
- Tests memory
- Updates and reads all communications busses (EIA-485, EIA-232, etc.)

4.4 Trouble Operation

With no alarms in the system, the detection of a trouble will cause the following:

- The piezo pulse 1 second On and 1 second Off
- The system Trouble LED to flash one second On and one second Off
- The trouble relay to activate
- *TROUBL* with device type, noun/adjective, address and trouble description will appear on the LCD display
- The same message, along with the time and date, is sent to the history buffer and optional printer
- Terminate upload or download communications

Note that specific troubles will initiate additional actions; for example, loss of AC power will turn off the AC Power LED, a ground fault will turn on the Ground LED, etc.

Addressable Smoke Detectors, Monitor Modules and Control Modules

For addressable devices connected to the SLC loop, the following is a typical message that could appear on the LCD display for a device trouble:

```

TROUBL SMOKE (PHOTO)
<ADJ> <NOUN>
      INVREP
10:00A 010810 10001
```

The information displayed in the above example provides the following information:

- First line in display:
 - The type of event; in this example *TROUBL* indicating a device trouble
 - Device type identifier; in this example, *SMOKE (PHOTO)* indicates a Photoelectric smoke detector. Other device type identifiers which can be displayed include *SMOKE (ION)* for Ionization Detector, *HEAT* for Heat Detector, *CONTROL* for Control Module and *MONITOR* for Monitor Module, *PULL STATION* for a manual pull box, etc. Refer to “Edit Detector” on page 69, “Edit Module Screen for Monitor Module” on page 79, and “Edit Module Screen for Control Modules” on page 88 for information on additional device types.
- Second line in display:
 - <ADJ>; refers to the user programmed adjective descriptor from library list resident in the control panel or custom entry via PC.
 - <NOUN>; refers to the user programmed noun descriptor from library list resident in the control panel or custom entry via PC.
- Third line in display: *INVREP* indicates an invalid reply from the addressable device. Other possible troubles include:
 - ✓ *SHORT* - indicating a shorted circuit on an addressable device
 - ✓ *OPEN* - indicating an open circuit on an addressable device
 - ✓ *DIRTY1* - maintenance alert indicating that a detector is near but below the allowed alarm limit and is in need of maintenance before the performance is compromised
 - ✓ *DIRTY2* - maintenance alert indicating that a detector needs immediate maintenance since it has been within 80% of its alarm threshold for 24 hours
 - ✓ *INVREP* - maintenance alert indicating a hardware problem in the detector
 - ✓ *TEST F* - indicating a detector has failed the automatic test operation which functionally checks its sensing chamber and electronics

- ✓ *INV ID* - indicating that an incorrect device code (Type ID) has been programmed for an installed device (for example, Photo has been programmed but an Ion detector has been installed)
- ✓ *SW TBL* - indicating a module has failed the testing of its Class A switching relay
- Fourth line in display:
 - Time; the current time in this example is *10:00A* which represents 10:00 AM
 - Date; the current month, day and year in this example is *01* for January, *08* for the 8th day of the month, and *10* for the year 2010
 - Device Address; *1D001* in this example *1* represents SLC Loop1, *D* represents a detector, and *001* represents device address 001

Pressing the *Acknowledge/Step* or *Alarm Silence* key will cause the pulsing piezo to silence and the system Trouble LED to change from flashing to on steady. This block acknowledgment occurs regardless of the number of troubles, alarms and supervisory events active in the system. When the *Acknowledge/Step* key is pressed and at least one new alarm or trouble exists in the system, the ‘acknowledge’ message is sent to the printer and history file. If the trouble clears, either before or after the *Acknowledge/Step* key is pressed, the ‘clear trouble’ message is sent to the printer and history file.

If all troubles clear and there are no supervisory or fire conditions active in the system, the system returns to normal mode operation and the *System All Normal* message is shown on the LCD display and sent to the history and printer files. The auto-restore feature will restore cleared troubles even if the troubles were never acknowledged. Note that pressing the *Alarm Silence* key when only troubles exist in the system will have the same effect as pressing the *Acknowledge/Step* key.

If multiple trouble conditions exist in the system, they will be automatically scrolled on the LCD display at a three second rate. *If a combination of alarms, troubles and/or supervisory conditions simultaneously occur in the system, only the alarms are scrolled on the display.*

4.5 Alarm Operation

Alarm operation is similar to trouble operation with the following differences:

- The piezo sounder produces a steady output as opposed to a pulsed output
- The Fire Alarm LED flashes 1 second On and 1 second Off
- The LCD displays *Alarm* along with the device name, type, address, adjective/noun, associated zones and time/date
- Alarms latch and *are not allowed to clear automatically*
- Alarms activate software zones if so programmed
- Timers for Silence Inhibit, Autosilence and Trouble Reminder are started
- Alarms activate the general alarm relay and general alarm zone Z00
- The trouble relay is not activated
- Store event in history buffer
- Terminate upload or download communications
- Alarms must be Acknowledged before the FACP can be reset

A typical alarm display would be as illustrated below:

```

ALARM PULL STATION
<ADJ> <NOUN>
      Z000
10:00A 010810 1M001
  
```

Note that the device type, which in this example is *PULL STATION*, can be any other programmable alarm type.

The information displayed in the above example provides the following information:

- First line in display:
 - The type of event; in this example *ALARM* indicating an alarm condition
 - Device type identifier; in this example, *PULL STATION* indicates a manual pull box. Other device type identifiers which can be displayed include *SMOKE (ION)* for Ionization Detector, *HEAT* for Heat Detector, *CONTROL* for Control Module and *MONITOR* for Monitor Module, *PULL STATION* for a manual pull box, etc. Refer to “Edit Detector” on page 69, “Edit Module Screen for Monitor Module” on page 79, and “Edit Module Screen for Control Modules” on page 88 for information on additional device types.
- Second line in display:
 - <ADJ>; refers to the user programmed adjective descriptor from library list resident in the control panel or custom entry via PC.
 - <NOUN>; refers to the user programmed noun descriptor from library list resident in the control panel or custom entry via PC.
- Third line in display: *Z000* indicates the zone programmed to this device which, in this example, is general alarm Zone 000. Note that a single device can be programmed to five different zones but only the first zone will be displayed.
- Fourth line in display:
 - Time; the current time in this example is *10:00A* which represents 10:00 AM
 - Date; the current month, day and year in this example is *01* for January, *08* for the 8th day of the month, and *10* for the year 2010
 - Device Address; *1M001* in this example *1* represents SLC Loop1, *M* represents a module, and *001* represents device address 001

4.6 Supervisory Operation

Supervisory operation is similar to alarm operation but with the following differences:

- The piezo sounder pulses ½ second On and ½ second Off
- The Supervisory LED flashes ½ second On and ½ second Off
- The LCD displays the status label *Active Supervisory* along with the device name, type, address, adjective/noun, associated zones and time/date
- The supervisory relay is activated
- The alarm relay is not activated
- Silenced alarms are not resounded
- Timers are not started
- Store event in history buffer
- Terminate upload or download communications
- Supervisory condition must be Acknowledged before the FACP can be reset

A typical Supervisory event would be displayed as illustrated in the following:

```

ACTIVE SUPERVISORY
<ADJ> <NOUN>
                Z000
10:00A 010810 1M001
  
```

Note that, like alarms, supervisory signals latch (except when programmed for supervisory autore-settable) and can be assigned to software zones. Supervisory alarms do not cause resound as do other alarm conditions. Open circuits in supervisory wiring are processed by the control panel the same way as other trouble conditions. Refer to “Alarm Operation” on page 153, for a description of the information displayed on the control panel LCD.

4.7 Process Monitor Operation

Process Monitor operation will initiate the following events:

- The piezo sounder pulses ¼ second On and ¼ second Off
- The LCD displays a process monitor message along with the device name, type, address, adjective/noun, associated zones and time/date
- Relays programmed for process monitoring will be activated
- The alarm relay is not activated
- Silenced alarms are not resounded
- Timers are not started
- Store event in history buffer
- Process Monitor condition must be Acknowledged before the FACP can be reset

Note that, like supervisories, process monitor signals latch (except when programmed for process monitor autoresettable) and can be assigned to software zones.

4.8 Hazard Condition Operation

Hazard Condition operation will initiate the following events:

- The piezo sounder turns on steady
- The LCD displays a hazard message along with the device name, type, address, adjective/noun, associated zones and time/date
- Relays programmed for process monitoring will be activated
- The alarm relay is not activated
- Silenced alarms are not resounded
- Timers are not started
- Store event in history buffer
- Hazard condition must be Acknowledged before the FACP can be reset

Hazard conditions latch and will therefore clear only when the hazard condition is cleared and the panel reset. They can be assigned to software zones.

4.9 Medical Alert Condition Operation

Medical Alert Condition operation will initiate the following events:

- The piezo sounder turns on steady
- The LCD displays a medical alert message along with the device name, type, address, adjective/noun, associated zones and time/date
- Relays programmed for medical alert will be activated
- The alarm relay is not activated
- Silenced alarms are not resounded
- Timers are not started
- Store event in history buffer
- Medical Alert condition must be Acknowledged before the FACP can be reset

Medical alert conditions latch and will therefore clear only when the medical alert condition is cleared and the panel reset. They can be assigned to software zones.

4.10 Programmed Zone Operation

Each addressable detector and monitor module can be assigned to a maximum of five software alarm zones. A general alarm zone Z00 may be listed for output (control) points, but it is not necessary to list Z00 for input points, since this is the default zone for all alarm input devices. Zone Z00 is also activated by supervisory points.

When an input device alarms and is not disabled, it activates all software zones assigned to it. An output device that is not disabled is turned on when any of the software zones to which it is programmed become active.

4.11 Disable/Enable Operation

Input points which are disabled do not cause an alarm or any zone activation. Disabled output points are held in the off state. All disabled points are treated as if they were in trouble, with the exception being the status label that will be displayed is *DISABL*.

4.12 Waterflow Circuits Operation

If an alarm exists from a monitor module point that has a waterflow type code and its mapped NAC control module outputs are programmed for nonsilenceable operation, the Alarm Silence key will not function.

4.13 Detector Functions

Maintenance Alert

Each addressable detector is monitored by the control panel for its maintenance status. If a detector is near but below the allowed alarm limit, a 'maintenance alert' message will automatically be displayed, signaling that the detector is in need of servicing.

Automatic Test Operation

An automatic test of an addressable detector is performed each minute, resulting in a complete SLC loop test in approximately 5 hours (if the loop has the maximum number of devices installed). The detector's sensing chamber and electronics are functionally tested for normal, safe operation. A trouble message is displayed upon failure of this test. A System Reset will clear this trouble.

Type Code Supervision

The FACP monitors addressable hardware device codes at slow intervals. Mismatch of any type code, compared to the system program, will cause a device trouble.

System Alarm Verification

The control panel may be programmed to perform alarm verification to help eliminate the nuisance of false alarms. Alarm verification applies to smoke detectors only.

Smoke Detector Data

Smoke detector data is monitored by the FACP, eliminating the need to test the sensitivity of each detector at its location. A printout of each detector's data can be retrieved from the FACP using an optional printer or Windows® HyperTerminal. Detector sensing ability can decrease with age and should be monitored as part of a system's routine maintenance.

4.14 Time Functions: Real-Time Clock

The FACP includes a crystal-based clock that provides time of day, date and day of week. Time is displayed as 12 or 24 hour time with month/day/year and is stored in RAM. Daylight savings time change-over is programmable and automatic. If both AC and battery are lost, the time must be reset.

4.15 NAC Operation

There are up to four programmable NACs (Notification Appliance Circuits) resident on the FACP main circuit board. The NACs may be programmed as silenceable or nonsilenceable and may also be programmed for steady or coded operation. Coded operation provides a choice between March Time, Temporal, California coding and two-stage operation.

4.16 Synchronized NAC Operation

Synchronization is a panel feature that controls the activation of notification appliances in such a way that all devices will turn on and off at exactly the same time. This is particularly critical when activating strobes which must be synchronized to avoid random activation and a potential hazard or confusion. The FACP can be programmed to operate with a variety of manufacturer's devices.

Important: When a Notification Appliance Circuit with a mix of audible and visual devices is programmed for silenceable and the synchronization feature is selected, only the audible devices will be turned off if the Silence key is pressed. The visual devices (strobes, etc.) will continue to operate.

4.17 Coded Operation

The NAC circuits resident on the control panel main circuit board can be programmed for coded operation. The available pulse rates which can be programmed for coded operation are as follows:

- Continuous: Steady output with no pulsing
- March Time: Pulses at 120 ppm (pulses per minute)
- Temporal Code: Pulses at ½ second On, ½ second Off, ½ second On, ½ second Off, ½ second On, 1½ second Off
- California Code: 10 seconds On, 5 seconds Off
- Two-Stage: Pulses at 20 ppm (pulses per minute) for 5 minutes and then changes to Temporal

4.18 Presignal

Presignal option programs an initiating device to delay the activation of NACs and/or control modules while allowing visual verification by a person. Once a detector or monitor module triggers an alarm, the onboard piezo sounds immediately, but the NACs are not activated for a user programmed time duration of up to three minutes. Note that the alarm relay and communicator will respond to the initial alarm immediately. In addition, Zone 98 will activate. This zone can be programmed to a control module which may be used to activate a sounder or indicator which the installer designates as a Presignal indication. *Do not assign Zone 98 to a Notification Appliance Circuit when using this zone to indicate a Pre-signal condition.*

After the programmed delay, the NACs will activate if the source of the alarm is not cleared. Note that if a second alarm occurs during the programmed time delay, the alarm will be processed immediately, causing activation of the appropriate output zones. The events which occur upon Presignal activation are as follows:

- onboard piezo sounds immediately
- control panel LCD display will indicate a presignal event and the active point
- control points programmed to Zone 98 will activate
- annunciators (if enabled) will sound the local piezo, and pulse the alarm LED and zone LED
- outputs (NACs and control modules) of associated zones will be inhibited from activating for a user programmed time delay of up to three minutes
- second alarm occurring anytime during the time delay will cause immediate activation of all associated outputs

Presignal does not affect monitor modules programmed as waterflow, supervisory, process monitoring or remote switches. *Presignal operation requires the approval of the local Authority Having Jurisdiction.*

4.19 Positive Alarm Sequence

PAS (Positive Alarm Sequence) option will program a smoke detector to delay panel activation (including alarm relay and communicator) for a period of 15 seconds. Zone 97, however, will activate immediately and may be used to connect a signaling device to indicate PAS activation. *Do not assign Zone 97 to a Notification Appliance Circuit when using this zone to indicate a PAS condition.*

When a detector triggers an alarm, the onboard piezo sounds immediately, but the NACs are prevented from activating for 15 seconds. This inhibit time is factory set and cannot be changed. Pressing the Alarm Silence or Acknowledge/Step key during the 15 second inhibit time will silence the piezo sounder and start a timer which prevents activation of NACs for an additional time duration which can be user programmed for up to three minutes. After the programmed delay, the NACs will activate if the source of the alarm is not cleared. Note that if a second alarm occurs during either time delay, the alarm will be processed immediately, causing activation of the appropriate output zones. The events which occur upon PAS activation are as follows:

- onboard piezo sounds immediately
- control panel LCD display will indicate a presignal event and the active point
- control points programmed to Zone 97 will activate
- ACS annunciators (if enabled) will pulse the Zone 97 PAS LED immediately upon PAS activation. They will sound the local piezo, and pulse the alarm, associated zone and detector address point LEDs after 15 seconds of an unacknowledged PAS activation. Note that if the Alarm Silence or Acknowledge/Step button is pressed, the annunciators will be inhibited from activating for an additional time delay
- outputs (NACs and control modules) of associated zones will be inhibited from activating for a factory set duration of 15 seconds

- pressing the Alarm Silence or Acknowledge/Step key will start a timer which inhibits output activation for additional time delay of up to three minutes which is user programmable
- second alarm occurring anytime during either time delay will cause immediate activation of all associated outputs

PAS operation requires the approval of the local Authority Having Jurisdiction.

Note that the *PAS BYPASS* monitor type code, when activated, will inhibit the PAS capability until the *PAS BYPASS* monitor is deactivated. While PAS is inhibited, signaling devices will immediately place the control panel into alarm. This feature may be employed by wiring a normally open device, such as a switch, to a monitor module which has been programmed for *PAS BYPASS*.

4.20 Special System Timers

4.20.1 Silence Inhibit Timer

This option, if selected, prevents the *Alarm Silence* and *Reset* keys from functioning for 60 seconds following an alarm. A second alarm during this 60 second period will not cause the timer to restart with a new 60 seconds. *Silence Inhibit operation requires the approval of the local Authority Having Jurisdiction.*

4.20.2 Autosilence Timer

If Autosilence is selected, the notification appliances, programmed as silenceable, will automatically be silenced after a programmable duration of from 5 to 30 minutes. Pressing the *Drill* key will restart the timer. *Autosilence operation requires the approval of the local Authority Having Jurisdiction.*

4.20.3 Trouble Reminder

If selected, this feature causes a reminding 'beep' every 15 seconds during an alarm (after the *Alarm Silence* key is pressed) and every two minutes during a trouble condition (after the *Acknowledge/Step* or *Alarm Silence* key is pressed). The 'beeps' from the onboard piezo sounder will occur until the alarm or fault is cleared.

Note that if the trouble is not cleared within 24 hours, the piezo will resound, indicating that the trouble condition still exists.

4.20.4 Waterflow Retard Timer

If selected, this option will delay the activation of a waterflow type alarm for a programmable time duration from 1 to 90 seconds. This delay is in addition to any time delay inherent in the waterflow device. *This feature requires the approval of the local Authority Having Jurisdiction.*

4.20.5 Alarm Verification

If alarm verification is selected, an addressable smoke detector's alarm is ignored for a Retard time of 13 seconds and the detector's alarm condition is automatically reset. There will be no alarm indication at the FACP during the Retard period. A Confirmation period of 60 seconds follows, during which a subsequent alarm from the same detector will cause the panel to immediately activate the appropriate outputs and indicate the alarm condition at the FACP. If a different detector alarms any time during the first detector's verification period, the panel will immediately activate

all appropriate outputs and indicate the alarm condition at the FACP. If no additional detector alarms occur within 73 seconds of the first alarm (13 second Retard plus 60 second Confirmation), the timer resets and the panel is ready to verify any new detector alarms which may occur.

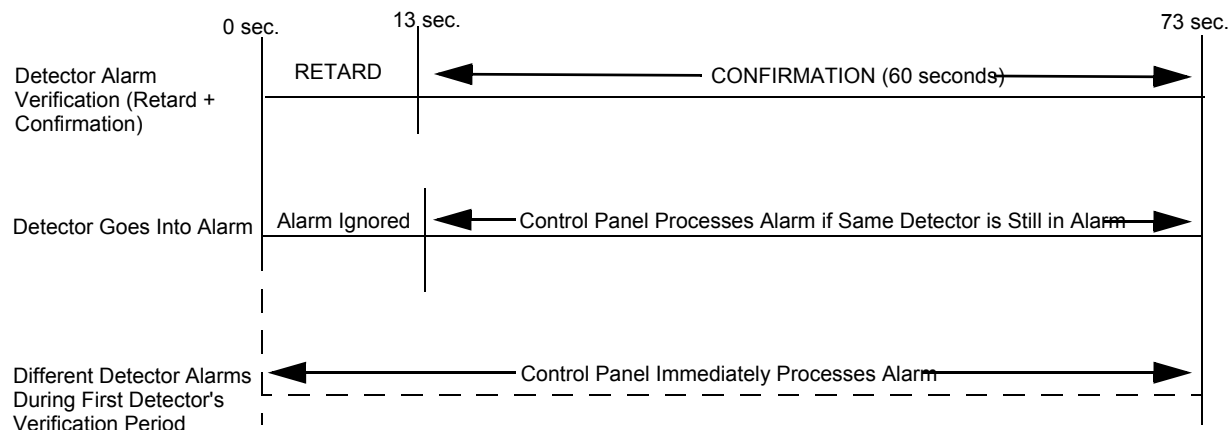

NOTE: Alarm Verification is available only for addressable smoke detectors, not conventional smoke detectors.

4.21 Walktest

Walktest is a feature which allows one person to test the fire alarm system. An audible walktest will momentarily sound the Notification Appliance Circuits in the building and store the walktest information in a file at the panel. A silent walktest will not sound the NACs but will store the walktest information in a file which can be viewed at the panel. Disabled NAC devices will not activate during walktest.

Alarm/Shorted Condition

When in audible Walktest, the panel responds to each new alarm and activates its programmed control outputs for four seconds, if those outputs have been programmed for silenceable activation. It also stores each alarm in the walktest history file which can be sent to an optional printer. The stored display will be the same as if the device actually activated except the colon (:) in the time stamp is replaced with an asterisk (*).

Open Condition

Addressable devices are monitored for fault conditions during Walktest mode. When a new trouble condition occurs, the FACP will activate all NACs and control modules programmed for Walktest and mapped to the faulted device, then shut them off after eight seconds.

While in Walktest, the trouble relay is activated and the system Trouble LED flashes (as in all of the Program and status change operations). The alarm relay is not activated.

4.22 Read Status

Read Status functions do not require a password. The control panel will continue to provide fire protection while in Read Status mode. This mode can be entered while the control panel is in alarm or trouble. If a new alarm or trouble occurs during these functions, the Read Status is exited to prevent confusion.

Read Status Entry

When the operator presses the control panel *Enter* key, the LCD will display the following:

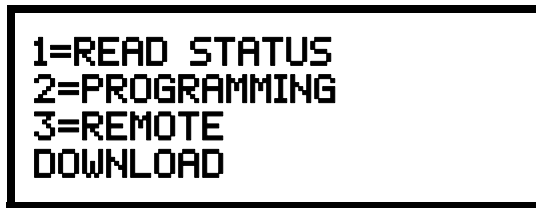

Pressing *1*, while this screen is being displayed, will cause the control panel to enter the Read Status mode which allows the user to view and print the programmed features and status of the control panel.

The following screens will be displayed:

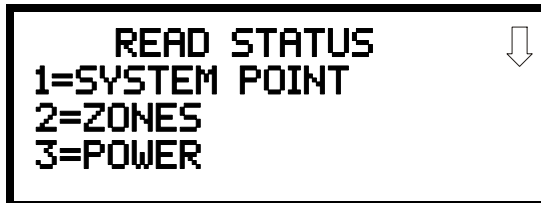

Read Status Screen #1

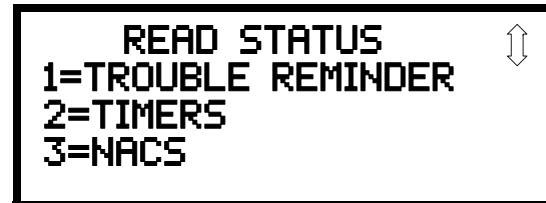

Read Status Screen #2

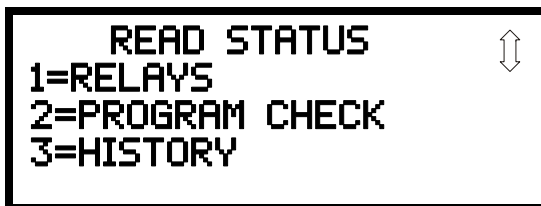

Read Status Screen #3

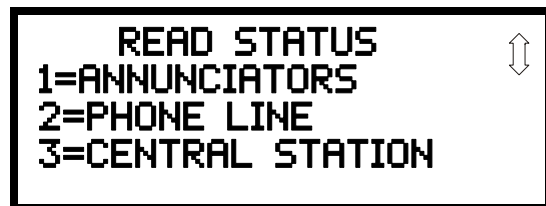

Read Status Screen #4



Read Status Screen #5



Read Status Screen #6

4.22.1 System Point

```

READ STATUS
1=SYSTEM POINT
2=ZONES
3=POWER

```

Read Status Screen #1

Pressing *1* while viewing Read Status Screen #1 will cause the following screen to be displayed:

```

READ SYSTEM POINT
SELECT LOOP
1=LOOP 1
2=LOOP 2

```

The operator selects the loop containing the device to be read by pressing *1* for Loop 1 or *2* for Loop 2. The following screen will then be displayed:

```

READ SYSTEM POINT
SELECT TYPE
1=DETECTOR
2=MODULE

```

The operator now selects the type of device which is to be viewed by pressing *1* for Detector or *2* for Module. If *1* is pressed, the display will change to the following screen:

```

READ SYSTEM POINT
ENTER DETECTOR#
***

```

Entering the three digit detector address will cause the control panel to display the current status of the selected device. For example, if a detector with address *001* on loop *1* is entered, a display similar to the following will appear:

```

NORMAL SMOKE(PHOTO)
NORTH CLASSROOM
      Z005
      1D001

```

The information in the preceding display includes:

- *NORMAL* - the present status (could also be ALARM, TROUBL, DISABL, etc.)
- *SMOKE (PHOTO)* - the device type which is a photoelectric smoke detector (could also be ION for ionization smoke detector)
- *NORTH CLASSROOM* - the Adjective/Noun label for this device
- *Z005* - the first of five possible assigned software zones
- *1D001* - *1* = Loop 1, *D* = Detector, *001* = Address 001

Pressing the down arrow key, while viewing the screen shown on the previous page, will allow the operator to view additional programming information about the selected device, such as:

- Enable/Disable Status
- Device Type
- Alarm Verification On/Off
- Walktest Yes/No
- PAS (Positive Alarm Sequence) Yes/No
- Pre-Signal Yes/No
- Zone Assignments (five maximum)
- Chamber Reading
- Adjective/Noun descriptor
- Silenceable Yes/No (for control modules)

4.22.2 Zones

Pressing 2 while viewing Read Status Screen #1 will cause the following screens to be displayed:

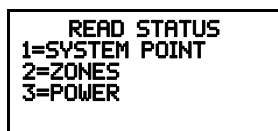

Read Status Screen #1



Zones Screen #1



Zones Screen #2

From the preceding screens, the control panel operator can view:

- *Zones Installed* - all software zones programmed into the system (99 maximum)
- *Zones Enabled* - all software zones that are enabled
- *Zones Disabled* - all software zones that have been disabled
- *Special Purpose* - on or off programming for Special Purpose Zones 97 reserved for PAS, 98 reserved for Pre-signal and 99 reserved for future use
- *Zone Type* - the Type assigned to each installed zone (default is Alarm)
- *Zone Message* - the message assigned to each installed zone

4.22.3 Power

Pressing 3 while viewing Read Status Screen #1 will display the following screens:

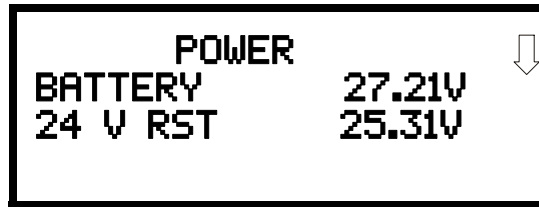

Zones Screen #1

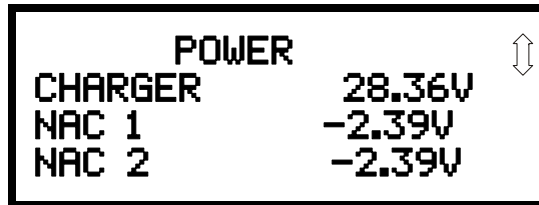

Zones Screen #2

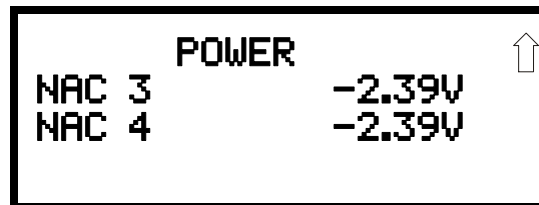

Zones Screen #3

A real-time display of control panel voltages can be used to determine if system problems exist. *Note that Zones Screen #3 will only be displayed if the NACKEY NAC option card is installed, in JP8 of the main circuit board, for Class B operation.*

The following table lists the circuit being measured, possible conditions and their respective voltage ranges:

Circuit	Condition	Voltage Range
Battery	Normal Battery (nominal)	27.05 to 28.15 VDC
	Low Battery	20.0 to 20.8 VDC
	No Battery	0 to 18.36 VDC
24V Resettable	Normal	21.25 to 27.50 VDC
24V Nonresettable	Normal	21.25 to 27.50 VDC
Charger	Normal	27.05 to 28.15 VDC
NACs	Normal	-1.3 to -1.6 VDC
	Open Circuit	-2.3 to -2.5 VDC
	Short Circuit	0 to 1.0 VDC

4.22.4 Trouble Reminder

Pressing 1 while viewing Read Status Screen #2 will display the following screen:

```

READ STATUS
1=TROUBLE REMINDER
2=TIMERS
3=NACS
  
```

Read Status Screen #2

```

TROUBLE REMINDER
TROUBLE REM      ON
  
```

The screen indicates whether the Trouble Reminder feature is On or Off.

4.22.5 Timers

Pressing 2 while viewing Read Status Screen #2 will cause the following Timer screens to be displayed:

```

          TIMERS
PAS DELAY      000
PRE SIGNAL     000
WATERFLOW     000
  
```

```

          TIMERS
AC LOSS DELAY  4
  
```

These screens indicate the delay time, in seconds, for each of four possible delay options.

4.22.6 NAC

Pressing 3 while viewing Read Status Screen #2 will display the following screen:

```

          NAC
1=NAC 1      3=NAC 3
2=NAC 2      4=NAC 4
  
```

Note that 3=NAC 3 and 4=NAC 4 will only be displayed if the NACKEY NAC option card is installed, in JP8 of the main circuit board, for Class B operation.

The operator can press 1 to view the programmed options for NAC 1, 2 to view the programmed options for NAC 2, 3 to view the programmed options for NAC 3, or 4 to view the programmed options for NAC 4. The resulting screens will display the following information:

- Enable/Disable Status
- Circuit Type (Bell, Strobe, etc.)
- Silenceable/Nonsilenceable
- Auto Silence Enable/Disable and time delay
- Coding Selection (Temporal, Steady, etc.)
- Zone Assignments
- Silence Inhibit Enabled/Disabled
- Synchronization Type (System Sensor, Wheelock or Gentex)

4.22.7 Relays

```

READ STATUS
1=RELAYS
2=PROGRAM CHECK
3=HISTORY
  
```

Read Status Screen #3

Pressing 1 while viewing Read Status Screen #3 will display the following screen:

```

          RELAYS
1=RELAY 1
2=RELAY 2
3=RELAY 3
  
```

The operator can view the programmed option for each relay by pressing the corresponding number key.

4.22.8 Program Check

Pressing 2 while viewing Read Status Screen #3 will cause a screen similar to the following to be displayed:

```

PROGRAM CHECK
1=NACS NO INPUT
2=ZONES NO INPUT
3=ZONES NO OUTPUT
  
```

Pressing 1 while viewing the Program Check screen will display a screen which will indicate if any input zones have not been programmed to one of the Notification Appliance Circuits. Use the up and down arrow keys to view all NACs.

Pressing 2 while viewing the Program Check screen will display a screen which will indicate if any output zones have not been programmed to at least one input zone. Use the up and down arrow keys to view all zones.

Pressing 3 while viewing the Program Check screen will display a screen which will indicate if any input zones have not been programmed to at least one output zone. Use the up and down arrow keys to view all zones.

4.22.9 History

Pressing 3 while viewing Read Status Screen #3 will display the following screen:

```

HISTORY
1=VIEW ALL
2=VIEW ALARMS
3=VIEW OTHER EVENTS
  
```

The operator can view all events which have been stored in the history file, only alarms or other events, such as troubles or supervisories, by pressing the corresponding number key.

4.22.10 Annunciators

Pressing 1 while viewing Read Status Screen #4 will display the following screens:

```

READ STATUS
1=ANNUNCIATORS
2=PHONE LINES
3=CENTRAL STATION
  
```

Read Status Screen #4

```

ANNUNCIATORS
TERM ENABLED      YES
2=ACS OPTIONS
3=ANN-BUS OPTIONS
  
```

Annunciator Screen

The Annunciator Screen indicates if Terminal mode options are enabled or disabled.

Pressing 2 for *ACS Options* while viewing the Annunciator Screen allows the operator to view the ACS Options screen:

```

      ACS OPTIONS
    ACS ENABLED      NO
  2=ACS ADDRESSES
    UDACT ENABLED   NO
  
```

ACS Options Screen

The ACS Options screen indicates if the ACS option has been enabled *YES* or disabled *NO*.

Pressing 2 for *ACS Addresses* while viewing the ACS Options screen will display screens with ACS addresses 1 -31 and whether a device is installed at that address *YES* or not installed *NO*.

The ACS Options screen indicates if a UDACT is installed *YES* or if a UDACT is not installed *NO*.

Pressing 3 for *ANN-BUS Options* while viewing the Annunciator Screen will display the following screens:

```

      ANN-BUS
    ENABLED          NO
  2=MODULES INSTALLED
  3=ANN-S/PG OPTIONS
  
```

ANN-BUS Screen #1

```

      ANN-BUS
    1=ANN-80 OPTIONS
  
```

ANN-BUS Screen #2

The ANN-BUS Screen #1 indicates if the ANN-BUS has been enabled *YES* or disabled *NO*.

Pressing 2 for *Modules Installed* while viewing ANN-BUS Screen #1 will display screens for ANN-BUS Addresses 1 -8 and the devices installed at each address. Subscreen will display the options that have been programmed for each device.

Pressing 3 for *ANN-S/PG Options* while viewing ANN-BUS Screen #1 will display the options selected for the installed serial or parallel printer.

Pressing 1 for *ANN-80 Options* while viewing ANN-BUS Screen #2 will display the options selected for the installed ANN-80 annunciators.

4.22.11 Phone Line

Pressing 2 while viewing Read Status Screen #4 will display the following screen:

```

PHONE LINE
PRIMARY TOUCHTONE
SECONDARY TOUCHTONE
3=SUPERV PHONE LINE
  
```

The second and third lines of this screen indicate that both the Primary and Secondary phone lines have been configured for touchtone dialing operation.

Pressing 3 while viewing the Phone Line screen will cause the following screen to be displayed:

```

SUPERVISE PHONE LINE
PHONE LINE 2      NO
  
```

This screen indicates whether or not Phone Line 2 is being supervised. In this example, PHONE LINE 2 NO indicates the phone line is not being supervised.

4.22.12 Central Station

```

READ STATUS
1=ANNUNCIATORS
2=PHONE LINE
3=CENTRAL STATION
  
```

Read Status Screen #4

Pressing 3 while viewing Read Status Screen #4 will display the following screens:

```

CENTRAL STATION
REPORTING      ENABLED
REPORT        FIRST AVAIL
CALL LIMIT    10
  
```

Central Station Screen #1

```

CENTRAL STATION
1=PRIMARY
2=SECONDARY
REPORT STYLE   ZONE
  
```

Central Station Screen #2

Central Station Screen #1 indicates whether the Central Station Reporting is enabled or disabled, if the Reports will be sent to the First Available or Backup Primary and Secondary Central Station phone numbers and Call Limit for DACT trouble calls within a 24 hour period. Central Station Screen #2 provides information on the Report Style (Zone or Point) as well as the Primary and Secondary Central Station programming which includes:

- Test Time Interval
- Account Code
- 24 Hour Test Time
- Phone Number
- Communication Format
- Event Codes

4.22.13 Service Terminal

Pressing 1 while viewing Read Status Screen #5 will display the following screens:

```
READ STATUS
1=SERVICE TERMINAL
2=PRINTER/PC
3=PRINT
```

Read Status Screen #5

```
SERVICE TERMINAL
RING COUNT      05
```

Service Terminal Screen

The Ring Count is displayed in the Service Terminal Screen. A Ring Count value of 00 would indicate that calling is disabled.

4.22.14 Printer/PC

Pressing 2 while viewing Read Status Screen #5 will display the following screen:

```
PRINTER PC
PRINTER PC    PR4800
```

Printer/PC Screen

The display will inform the operator as to whether the control panel is configured for a printer or a PC and if the printer is supervised. In the example above, *PR4800* indicates that the panel is configured for a printer with a baud rate of 4800 and *PR* indicates that the printer is being supervised. If *NS* appeared in place of *PR*, it would indicate that the printer is not supervised.

4.22.15 Print

To print program data or control panel status, press 3 while viewing Read Status Screen #5. The following screens will be displayed:

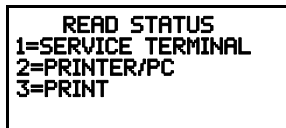

Read Status Screen #5



Print Screen #1

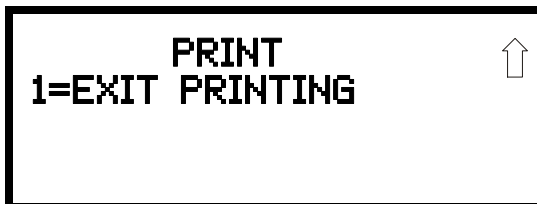

Print Screen #2

Pressing 1 while viewing Print Screen #1 allows the user to print the History file which will detail all of the system activities since the file was last cleared from memory.

Pressing 2 while viewing Print Screen #1 allows the user to print the Walktest log which will detail all of the system activations during walktest since the log was last cleared. Refer to “Walktest” on page 160 for additional information on the display.

Pressing 3 while viewing Print Screen #1 allows the user to print the detector data for each addressable smoke detector connected to the system. A printout, similar to the following example, will be generated if an optional printer is connected to the FACP.

DEVICE #	DEVICE TYPE	%DRIFT COMP	CHAMBER	TIME/DATE
1D001	SMOKE (PHOTO)	20	1281	12:01AM 01-08-2001
1D002	SMOKE (PHOTO)	20	1281	12:01AM 01-08-2001
1D003	SMOKE (PHOTO)	21	1259	12:01AM 01-08-2001
1D004	SMOKE (PHOTO)	20	1309	12:02AM 01-08-2001
1D005	SMOKE (PHOTO)	21	1281	12:02AM 01-08-2001
1D006	SMOKE (PHOTO)	20	1322	12:02AM 01-08-2001
1D007	SMOKE (PHOTO)	20	1280	12:02AM 01-08-2001
1D008	SMOKE (PHOTO)	20	1215	12:02AM 01-08-2001
1D009	SMOKE (PHOTO)	20	1310	12:02AM 01-08-2001

Chamber Value

The Chamber value should be within the indicated range for the following smoke detectors:

- SD350(T), SD355(T), D350P(R), SD300(T), AD350 and AD355 Addressable Photoelectric Smoke Detectors: **405 - 2100** (obscuration of 1.00%/ft to 3.66%/ft.)
- CP350, CP355 and CP300 Addressable Ionization Smoke Detectors: **750 - 2100** (obscuration of 0.50%/ft. to 1.44%/ft.)

If the addressable smoke detector’s Chamber reading is not within the acceptable range, clean the detector and check the Chamber value again. If the reading is still not within the acceptable range, immediately replace the detector.

Drift Compensation

Drift compensation uses software algorithms that identify and compensate for long-term changes in the data readings from each addressable smoke detector. These long-term changes in detector data readings are typically caused by dirt and dust accumulation inside the smoke chamber. Drift compensation performs the following functions:

- Samples each photoelectric smoke detector every 6 seconds and each ionization smoke detector every 3 seconds
- Allows a smoke detector to retain its original ability to detect actual smoke and resist false alarms, even as dirt and dust accumulate
- Reduces maintenance requirements by allowing the control panel to automatically perform the periodic sensitivity measurements required by NFPA Standard 72

The FACP software also provides filters to remove transient noise signals, usually caused by electrical interference.

Maintenance Alert

The software determines when the drift compensation for a detector reaches an unacceptable level that can compromise detector performance. When a detector reaches an unacceptable level, the control panel indicates a maintenance alert. Table 4.1 summarizes the three levels of maintenance alert:

Maintenance Level	FACP Status Displays	Indicates
Low Chamber Value	INVREP	A hardware problem in the detector
Maintenance Alert	DIRTY1	Dust accumulation that is near but below the allowed limit. <i>DIRTY 1</i> indicates the need for maintenance before the performance of the detector is compromised
Maintenance Urgent	DIRTY2	Dust accumulation above the allowed limit.

Table 4.1 Maintenance Alert Levels

Figure 4.1 illustrates a graphic representation of the maintenance levels:

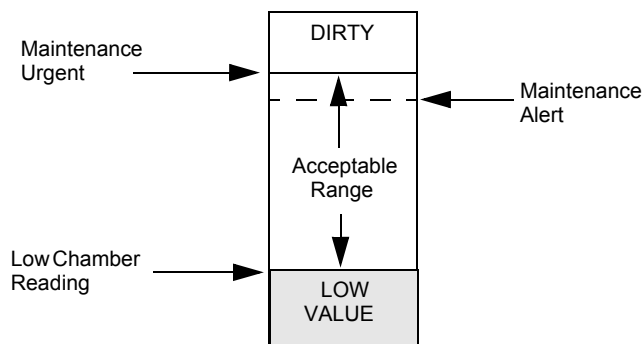

Figure 4.1 Diagram of Maintenance Levels

4.22.16 Time-Date

The operator can view the daylight savings time and the month and week when daylight savings time will begin and end. Pressing *I* while viewing Read Status Screen #6 will display the following screens:

READ STATUS
1=TIME-DATE

Read Status Screen #6

DAYLIGHT SAVINGS ↓
ENABLED YES
START MONTH MAR
START WEEK WEEK-2

DAYLIGHT SAVINGS ↑
END MONTH NOV
END WEEK WEEK-1

Section 5: Power Supply Calculations

5.1 Overview

This section contains instructions and tables for calculating power supply currents in alarm and standby conditions. This is a four-step process, consisting of the following:

1. Calculating the total amount of AC branch circuit current required to operate the system
2. Calculating the power supply load current for non-fire and fire alarm conditions and calculating the secondary (battery) load
3. Calculating the size of batteries required to support the system if an AC power loss occurs
4. Selecting the proper batteries for your system

5.2 Calculating the AC Branch Circuit

The control panel requires connection to a separate, dedicated AC branch circuit, which must be labeled **FIRE ALARM**. This branch circuit must connect to the line side of the main power feed of the protected premises. No other non-fire alarm equipment may be powered from the fire alarm branch circuit. The branch circuit wire must run continuously, without any disconnect devices, from the power source to the control panel. Overcurrent protection for this circuit must comply with Article 760 of the National Electrical Codes as well as local codes. Use 14 AWG (2.00 mm²) wire with 600 volt insulation for this branch circuit.

Use Table 5.1, to determine the total amount of current, in AC amperes (A), that must be supplied to the system.

Device Type	Number of Devices		Current Draw (AC amps)		Total Current per Device
MS-9600LS(C) MS-9600UDLS or MS-9600LSE MS-9600UDLSE	1	X	3.0 or 1.5	=	
CHG-120F	[]	X	2.0	=	
	[]	X	[]	=	
Sum Column for AC Branch Current Required				=	

Table 5.1 AC Branch Circuit Requirements

5.3 Calculating the System Current Draw

5.3.1 Overview

The control panel must be able to power all internal and external devices continuously during the non-fire alarm condition. To calculate the non-fire alarm load on the system power supply when primary power is applied, use Calculation Column 1 in Table 5.3 on page 176. The control panel must support a larger load current during a fire alarm condition. To calculate the fire alarm load on the power supply, use Calculation Column 2 in Table 5.3 on page 176. The secondary power source (batteries) must be able to power the system during a primary power loss. To calculate the non-fire alarm load on the secondary power source, use Calculation Column 3 in Table 5.3 on page 176.

When calculating current draw and the battery size, note the following:

- ‘Primary’ refers to the main power source for the control panel

- ‘Secondary’ refers to the control panel’s backup batteries
- All currents are given in amperes (A). Table 5.2 shows how to convert milliamperes and microamperes to full amperes.

To convert...	Multiply	Example
Milliamperes (mA) to amperes (A)	mA x 0.001	3 mA x 0.001 = 0.003A
Microamperes (µA) to amperes (A)	µA x 0.000001	300 µA x 0.000001 = 0.0003 A

Table 5.2 Converting to Full Amperes

5.3.2 How to Use Table 5.3 on page 176 to Calculate System Current Draw

Use Table 5.3 on page 176 to calculate current draws as follows:

1. Enter the quantity of devices in all three columns.
2. Enter the current draw where required. Refer to the Device Compatibility Document for compatible devices and their current draw.
3. Calculate the current draws for each in all columns.
4. Sum the total current for each column.
5. Copy the totals from Column 2 and Column 3 to Table 5.4 on page 177.

Following are the types of current that can be entered into Table 5.3 on page 176:

- ✓ **Calculation Column 1** - The primary supply current load that the control panel must support during a non-fire alarm condition, with AC power applied.
- ✓ **Calculation Column 2** - The primary supply current load that the control panel must support during a fire alarm condition, with AC power applied.
- ✓ **Calculation Column 3** - The standby current drawn from the batteries in a non-fire alarm condition during a loss of AC power.

Table 5.3 contains columns for calculating current draws. For each column, calculate the current and enter the total (in amperes) in the bottom row. When finished, copy the totals from Calculation Column 2 and Calculation Column 3 to Table 5.4 on page 177.

Device Type	Calculation Column 1 Primary, Non-Fire Alarm Current (amps)			Calculation Column 2 Primary, Fire Alarm Current (amps)			Calculation Column 3 Secondary, Non-Fire Alarm Current (amps)		
	Qty	X[current draw]=	Total	Qty	X [current draw] =	Total	Qty	X[current draw]=	Total
Main Circuit Board	1	X[0.160]=	0.160	1	X[0.253]=	0.253	1	X[0.103]=	0.103
ANN-80	[]	X[0.037]=		[]	X[0.040]=		[]	X[0.015]=	
ANN-(R)LED	[]	X[0.028]=		[]	X[0.068]=		[]	X[0.028]=	
ANN-RLY	[]	X[0.015]=		[]	X[0.075]=		[]	X[0.015]=	
ANN-I/O	[]	X[0.035]=		[]	X[0.200]=		[]	X[0.035]=	
ANN-S/PG	[]	X[0.045]=		[]	X[0.045]=		[]	X[0.045]=	
ACM-8RF	[]	X[0.030]=		[]	X[0.158] ¹ =		[]	X[0.030]=	
ACM-16ATF	[]	X[0.040]		[]	X[0.056] ² =		[]	X[0.040]=	
ACM-32AF	[]			[]			[]		
AEM-16ATF	[]	X[0.002]		[]	X[0.018] ² =		[]	X[0.002]=	
AEM-32AF	[]			[]			[]		
AFM-16ATF	[]	X[0.040]		[]	X[0.056] ² =		[]	X[0.040]=	
AFM-32AF	[]			[]			[]		
AFM-16AF	[]	X[0.025]		[]	X[0.065] ² =		[]	X[0.025]=	
DACT-UD2	[]	X[0.020]		[]	X[0.029]=		[]	X[0.017]=	
LDM-32F	[]	X[0.040]		[]	X[0.056] ³ =		[]	X[0.040]=	
LDM-E32F	[]	X[0.002]		[]	X[0.018]=		[]	X[0.002]=	
LCD-80F & LCD-80FC	[]	X[0.064]		[]	X[0.064]=		[]	X[0.025]=	
4XTMF	[]	X[0.005]=		[]	X[0.011] ³ =		[]	X[0.005]=	
4-wire Detector Heads	[]	X[] ³ =		[]	X[] ³ =		[]	X[] ³ =	
Power Supervision Relays ⁶	[]	X[0.025]=		[]	X[0.025]=		[]	X[0.025]=	
SLC-2LS Expander	[]	X[0.02500]=		[]	X[0.02600]=		[]	X[0.01900]=	
CP350 & CP355	[]	X[0.00030]=		[]			[]	X[0.00030]=	
SD350 & SD355	[]	X[0.00030]=		[]			[]	X[0.00030]=	
SD350T & SD355T	[]	X[0.00030]=		[]			[]	X[0.00030]=	
AD350 & AD355	[]	X[0.00030]=		[]			[]	X[0.00030]=	
H350 & H355	[]	X[0.00030]=		[]			[]	X[0.00030]=	
H350R & H355R	[]	X[0.00030]=		[]			[]	X[0.00030]=	
H355HT	[]	X[0.00030]=		[]			[]	X[0.00030]=	
D350P & D350PL	[]	X[0.00030]=		[]			[]	X[0.00030]=	
D350RP & D350RPL	[]	X[0.00030]=		[]			[]	X[0.00030]=	
B501BH & B501BHT ⁷	[]	X[0.001]=		[]			[]	X[0.001]=	
B224RB Relay Base	[]	X[0.00050]=		[]			[]	X[0.00050]=	
B224BI Isolator Base	[]	X[0.00045]=		[]			[]	X[0.00045]=	
MMF-300	[]	X[0.00040]=		[]			[]	X[0.00040]=	
MMF-300-10	[]	X[0.00350]=		[]			[]	X[0.00350]=	
MDF-300	[]	X[0.00075]=		[]			[]	X[0.00075]=	
MMF-301	[]	X[0.000375]=		[]			[]	X[0.000375]=	
MMF-302	[]	X[0.00027]=		[]			[]	X[0.00027]=	
MMF-302-6	[]	X[0.00200]=		[]			[]	X[0.00200]=	
BG-12LX	[]	X[0.00030]=		[]			[]	X[0.00030]=	
CMF-300	[]	X[0.00039]=		[]			[]	X[0.00039]=	
CMF-300-6	[]	X[0.00225]=		[]			[]	X[0.00225]=	
CRF-300	[]	X[0.00027]=		[]			[]	X[0.00027]=	
CRF-300-6	[]	X[0.00145]=		[]			[]	X[0.00145]=	
I300	[]	X[0.00040]=		[]			[]	X[0.00040]=	
NAC #1 ⁸				[]	X[] ⁹ =				
NAC #2				[]	X[] ⁹ =				
NAC #3				[]	X[] ⁹ =				
NAC #4				[]	X[] ⁹ =				
Current Draw from TB3 (nonalarm ⁹)		[] =		[]	[] =		[]	[] =	
Sum each column¹⁰ for totals	Primary Non-Alarm =			Primary Alarm =			Secondary Non-Alarm =		

Table 5.3 System Current Draw Calculations

- 1 All eight ACM-8RF relays activated on a single module.
- 2 All annunciator LEDs on
- 3 LDM-32F with LEDs on
- 4 If using the Reverse Polarity Alarm output, add 0.005 amps; if using the Reverse Polarity Trouble output, add another 0.005 amps.
- 5 Refer to the Device Compatibility Document for standby current.
- 6 Must use compatible listed Power Supervision Relay.
- 7 Maximum alarm current for each sounder base is 0.015 amps which must be supplied by aux. 24VDC source.
- 8 Current limitation of Terminal TB4 circuits is 3.00 amps per NAC.
- 9 The total standby current must include both the resettable (TB3 Terminals 1 & 2) and nonresettable (TB3 Terminals 3 & 4, 5 & 6) power. Caution must be taken to ensure that current drawn from these outputs during alarm does not exceed maximum ratings specified. Current limitations of TB3 circuits is 3.0 amps per output
- 10 Total current draw listed above cannot exceed 7.0 amps in alarm.

5.4 Calculating the Battery Size

Use Table 5.4 to calculate the total Standby and Alarm load in ampere hours (AH). This total load determines the battery size (in AH), required to support the control panel under the loss of AC power. Complete Table 5.4 as follows:

1. Enter the totals from Table 5.3 on page 176, Calculation Columns 2 and 3 where shown.
2. Enter the NFPA Standby and Alarm times (refer to 'NFPA Requirements' below).
3. Calculate the ampere hours for Standby and Alarm, then sum the Standby and Alarm ampere hours.
4. Multiply the sum by the derating factor of 1.2 to calculate the proper battery size (in AH).
5. Write the ampere hour requirements on the Protected Premises label located inside the cabinet door.

Secondary Standby Load (total from Table 5.3 Calculation Column 3) []	Required Standby Time (24 hours) X[]	= AH
Primary Alarm Load (total from Table 5.3 Calculation Column 2) []	Required Alarm Time (for 5 min., enter 0.084, for 10 min., enter 0.168) X[]	= AH
Sum of Standby and Alarm Ampere Hours		= AH
Multiply by the Derating Factor		X 1.2
Battery Size, Total Ampere Hours Required		= AH

Table 5.4 Total Secondary Power Requirements at 24 VDC

5.4.1 NFPA Battery Requirements

- NFPA 72 Local, Proprietary, Central, Auxiliary and Remote Station Fire Alarm Systems require 24 hours of standby power followed by 5 minutes in alarm
- NFPA requires 24 hours of standby plus 15 minutes activation for audio systems. The total ampere hours required cannot exceed 26 AH with an internal charger

5.4.2 Selecting and Locating Batteries

Select sealed lead acid batteries that meet or exceed the total ampere hours calculated in Table 5.4. The control panel can charge batteries in the 12 AH to 26 AH range. The control panel cabinet is capable of housing batteries up to 18 AH. Batteries larger than 18 AH require the BB-26, BB-55F, or other UL-listed external battery cabinet.

Appendix A: Software Zones

A.1 Correlations

Setup and configuration of an addressable system is different than a conventional system. In a conventional system, assignment of input devices (smoke detectors, pull stations, heat detectors, etc.) to zones is accomplished through wiring. The wiring is direct from clearly marked panel terminals to any device assigned to a particular zone. Connection of output devices (horns, bells, strobes, etc.) in a conventional system is accomplished by direct wiring of the output devices to Notification Appliance Circuit terminals.

In an addressable system, a minimum of a single pair of wires (SLC communication loop) is used to connect all addressable input and output devices. Communications between the FACP (Fire Alarm Control Panel) and all addressable devices takes place over the wire pair which originates from the FACP. Software programming is used to configure the system as opposed to direct wiring. Zone assignments are created via software means, hence the term *software zones*.

Setup of an FACP software zone is accomplished by panel programming. Each addressable device can be assigned to a maximum of five software zones. Each software zone, however, may have from 1 to 99¹ addressable input devices assigned to it and from 1 to 99¹ addressable output devices assigned to it.

Monitor and control modules comprise one group of 99¹ addresses, with each module having a unique address from 1 to 99¹. Detectors comprise a separate group of 99¹ addresses, each detector having a unique address from 1 to 99¹ in its group. Be careful not to duplicate addresses within any one group (modules and detectors). Refer to the following page for an example of zoning.

In the example on the following page:

- Zone 01 has the following addressable devices assigned to it:
 - SD350 smoke detectors with addresses 01 and 02
 - MMF-300 monitor module with address 01
 - MMF-302 monitor module with address 02 and 03
 - CMF-300 control modules with addresses 05, 06, 07, 09, and 13
- Zone 02 has the following addressable devices assigned to it:
 - MMF-302 monitor module with addresses 02 and 03
 - CP350 smoke detectors with addresses 03 and 04
 - CMF-300 control modules with addresses 08, 09, and 10
- Zone 03 has the following addressable devices assigned to it:
 - SD350 smoke detectors with addresses 05, 06, and 07
 - MMF-302 control module with address 04
 - CMF-300 control modules with addresses 09, 11, and 12

The example points out some of the key assignment features of the FACP. Addresses of detectors are not duplicated. Addresses of monitor and control modules are not duplicated. The control module with address 09 is assigned to three software zones (providing floor above and floor below). Be careful to properly plan the installation prior to installing any devices.

-
1. CLIP or Classic Loop Interface Protocol devices (modules and detectors) can only have unique addresses of 1 to 99. Newer LiteSpeed devices (modules and detectors) can have unique addresses of 1 to 159 which means each zone can have up to 159 input and output devices assigned to it.

Correlation of Input and Output Zones

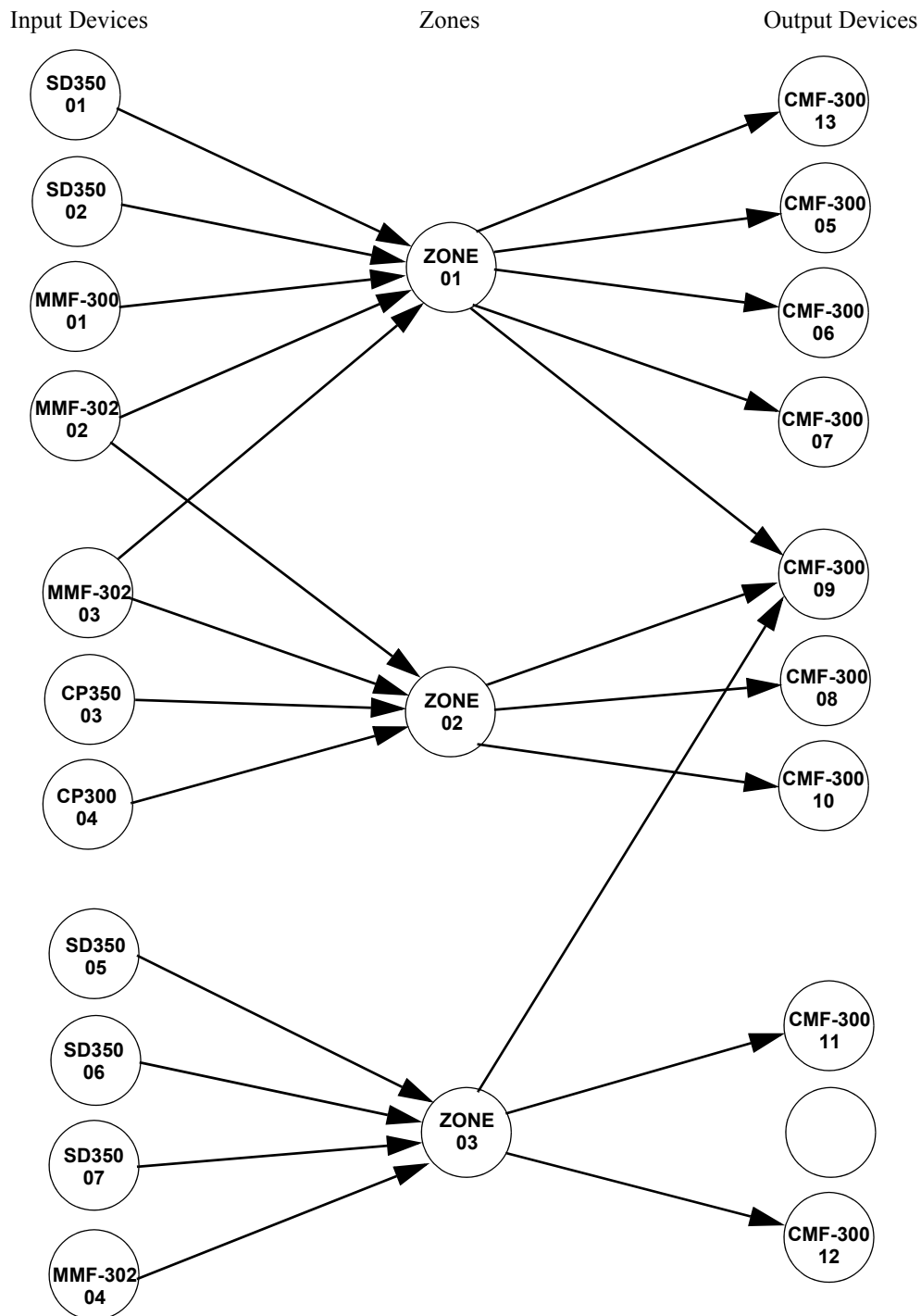

The zone correlations which are shown graphically above are also presented in Table A.1 on page 180 and Table A.2 on page 181.

DETECTOR ZONE ASSIGNMENT							
Address	Device Type	Zone Number	ADJ/NOUN	Address	Device Type	Zone Number	ADJ/NOUN
01	SD350	1	FIRST HALL	51			
02	SD350	1	ELEV. LOBBY	52			
03	CP350	2	2ND FLOOR	53			
04	CP350	2	ROOM 210	54			
05	SD350	3	3RD FLOOR	55			
06	SD350	3	MEZZANINE	56			
07	SD350	3	MECH. ROOM	57			
08				58			
09				59			
10				60			
11				61			
12				62			
13				63			
14				64			
15				65			
16				66			
17				67			
18				68			
19				69			
20				70			
21				71			
22				72			
23				73			
24				74			
25				75			
26				76			
27				77			
28				78			
29				79			
30				80			
31				81			
32				82			
33				83			
34				84			
35				85			
36				86			
37				87			
38				88			
39				89			
40				90			
41				91			
42				92			
43				93			
44				94			
45				95			
46				96			
47				97			
48				98			
49				99			
50				100			

Table A.1 Detector Programming Sheet Example

MONITOR/CONTROL MODULE ZONE ASSIGNMENT							
Address	Device Type	Zone Number	ADJ/NOUN	Address	Device Type	Zone Number	ADJ/NOUN
01	MMF-300	1		51			
02	MMF-302	1, 2		52			
03	MMF-302	1, 2		53			
04	MMF-302	3		54			
05	CMF-300	1		55			
06	CMF-300	1		56			
07	CMF-300	1		57			
08	CMF-300	2		58			
09	CMF-300	1, 2, 3		59			
10	CMF-300	2		60			
11	CMF-300	3		61			
12	CMF-300	3		62			
13	CMF-300	1		63			
14				64			
15				65			
16				66			
17				67			
18				68			
19				69			
20				70			
21				71			
22				72			
23				73			
24				74			
25				75			
26				76			
27				77			
28				78			
29				79			
30				80			
31				81			
32				82			
33				83			
34				84			
35				85			
36				86			
37				87			
38				88			
39				89			
40				90			
41				91			
42				92			
43				93			
44				94			
45				95			
46				96			
47				97			
48				98			
49				99			
50				100			

Table A.2 Module Programming Sheet Example

DETECTOR ZONE ASSIGNMENT							
Address	Device Type	Zone Number	ADJ/NOUN	Address	Device Type	Zone Number	ADJ/NOUN
01				51			
02				52			
03				53			
04				54			
05				55			
06				56			
07				57			
08				58			
09				59			
10				60			
11				61			
12				62			
13				63			
14				64			
15				65			
16				66			
17				67			
18				68			
19				69			
20				70			
21				71			
22				72			
23				73			
24				74			
25				75			
26				76			
27				77			
28				78			
29				79			
30				80			
31				81			
32				82			
33				83			
34				84			
35				85			
36				86			
37				87			
38				88			
39				89			
40				90			
41				91			
42				92			
43				93			
44				94			
45				95			
46				96			
47				97			
48				98			
49				99			
50				100			

Table A.3 Blank Detector Programming Sheet - 1 of 2

DETECTOR ZONE ASSIGNMENT							
Address	Device Type	Zone Number	ADJ/NOUN	Address	Device Type	Zone Number	ADJ/NOUN
101				151			
102				152			
103				153			
104				154			
105				155			
106				156			
107				157			
108				158			
109				159			
110							
111							
112							
113							
114							
115							
116							
117							
118							
119							
120							
121							
122							
123							
124							
125							
126							
127							
128							
129							
130							
131							
132							
133							
134							
135							
136							
137							
138							
139							
140							
141							
142							
143							
144							
145							
146							
147							
148							
149							
150							

Table A.4 Blank Detector Programming Sheet - 2 of 2

MONITOR/CONTROL MODULE ZONE ASSIGNMENT							
Address	Device Type	Zone Number	ADJ/NOUN	Address	Device Type	Zone Number	ADJ/NOUN
01				51			
02				52			
03				53			
04				54			
05				55			
06				56			
07				57			
08				58			
09				59			
10				60			
11				61			
12				62			
13				63			
14				64			
15				65			
16				66			
17				67			
18				68			
19				69			
20				70			
21				71			
22				72			
23				73			
24				74			
25				75			
26				76			
27				77			
28				78			
29				79			
30				80			
31				81			
32				82			
33				83			
34				84			
35				85			
36				86			
37				87			
38				88			
39				89			
40				90			
41				91			
42				92			
43				93			
44				94			
45				95			
46				96			
47				97			
48				98			
49				99			
50				100			

Table A.5 Blank Module Programming Sheet - 1 of 2

MONITOR/CONTROL MODULE ZONE ASSIGNMENT							
Address	Device Type	Zone Number	ADJ/NOUN	Address	Device Type	Zone Number	ADJ/NOUN
101				151			
102				152			
103				153			
104				154			
105				155			
106				156			
107				157			
108				158			
109				159			
110							
111							
112							
113							
114							
115							
116							
117							
118							
119							
120							
121							
122							
123							
124							
125							
126							
127							
128							
129							
130							
131							
132							
133							
134							
135							
136							
137							
138							
139							
140							
141							
142							
143							
144							
145							
146							
147							
148							
149							
150							

Table A.6 Blank Module Programming Sheet - 2 of 2

Appendix B: Default Programming

The following table provides a list of the programming options and their factory default settings.

Program Option	Factory Default	Program Option	Factory Default
Master Password	00000	NAC Enable	Enabled
Maintenance Password	11111	NAC Silenceable	Yes
Detector Programming	Not Installed	NAC Type	Bell
Detector Type	Smoke-Photo	NAC Sync Type	System Sensor
Detector Verification	Off	NAC Autosilence	0
Detector Walktest	Yes	NAC Coding	Steady
Detector PAS	No	NAC Zones	Zone 000 only
Detector Presignal	No	NAC Silence Inhibit	0
Detector Zone Assign.	000 only	Relay 1	Alarm
Detector Adj/Noun	none	Relay 2	Trouble
Module Programming	Not Installed	Relay 3	Supervisory
Module Type	Monitor	On Board DACT	No
Module Walktest	Yes	Annunciator Terminal Mode	No
(not used)		Annunciator ACS Mode	No
Module Presignal	No	UDACT	No
Module Zone Assign.	000 only	ACS Installed	No
Module Adj/Noun	none	Printer-PC	No
Zone 0 Enable	Enabled	Printer Baud	9600
Zone 1 Enable	Enabled	Canadian Option	Off
Zone 2 Enable	Enabled	Waterflow Silenceable	No
Zone 3 Enable	Enabled	ANN-BUS Enabled	No
.....through.....	Central Station Reporting	Disabled
Zone 99 Enable	Enabled	AC Loss Delay	2 Hours
Special Zones 97, 98 & 99	Disabled	DACT Backup Reporting	First Available
Zones 0 - 99 Type	Monitor	DACT Report Style	By Point
Loop 1 & 2 Style	Style 4	ANN Enabled	No
Loop 1 & 2 Protocol	LiteSpeed	ANN-BUS Modules Addr. 1 - 8	None
Trouble Reminder	Off	ANN-S/PG Port	Parallel
Banner		ANN-S/PG Baud	9600
Time Format	12 Hr	ANN-S/PG Data Bits	7
Hours Setting	12	ANN-S/PG Parity	Even
Minutes Setting	00	ANN-S/PG Stop Bits	1
Second Settings	00	ANN-S/PG Offline Timer	60
AM-PM Setting	AM	ANN-S/PG Printer Supervision	No
Month Setting	01	ANN-80 Piezo Enabled	Yes
Day Setting	01	ANN-80 Lock Enabled	Yes
Year Setting	00	ANN-80 Acknowledge Button Enabled	Yes
PK-Plus Secret Code	00000000	ANN-80 Silence Button Enabled	Yes
Trouble Call Limit	0	ANN-80 Reset Button Enabled	Yes
Daylight Savings	Yes	ANN-80 Drill Button Enabled	Yes
Month Start Daylight Savings	March	ANN-I/O Point/Zone	Zone
Week Start Daylight Savings	2nd Week	ANN-I/O Range	00-29
Month End Daylight Savings	November	ANN-I/O Active LEDs Only	
Week End Daylight	1st Week	ANN-RLY Relay 1	Zone 1
Verification	Nothrough.....
Ring Count	0	ANN-RLY Relay 10	Zone 10
PAS Timer	0	ANN-LED Point/Zone	Zone
Presignal Timer	0	ANN-LED Alarms/ATS (Alarm, Trbl, Supv)	ATS
Waterflow Retard Timer	0	ANN-LED Range	0 - 9

Appendix C: NFPA Standard-Specific Requirements

The FACP has been designed for use in commercial, industrial and institutional applications and meets the requirements for service under the National Fire Protection Association (NFPA) Standards outlined in this Appendix. The minimum system components required for compliance with the appropriate NFPA standard are listed below:

Fire Alarm Control Panel

Contains the main control board, cabinet (backbox and door), main power supply transformer and power supply.

Batteries

Refer to “Power Supply Calculations” on page 174, for Standby Power Requirements.

Initiating Devices

Connected to one of the control panel's Initiating Device Circuits.

Notification Appliances

Connected to the control panel's Notification Appliance Circuits via a control module.

The following additional equipment is needed for compliance with the NFPA 72 standards listed below:

NFPA 72 NATIONAL FIRE ALARM STANDARDS FOR:

NFPA 72 Central Station Service (Protected Premises Unit) or Remote Station Service

411UDAC for connection to a compatible listed Central Station DACR or Protected Premises Receiving Unit. This unit must be installed as outlined in Figure C.1, “Central Station Service Using 411UDAC,” on page 188.

OR

411UD may be installed as illustrated in Figure C.2, “FACP Connection to 411UD,” on page 189.

OR

4XTMF Transmitter Module for connection to the RS82 Remote Station Receiver. See Figure C.4, “Remote Station Connection Using 4XTMF Module,” on page 191, for installation instructions for this unit.

NFPA 72 Auxiliary Fire Alarm System

4XTMF Transmitter Module for connection to a compatible listed Local Energy Municipal Box. This unit must be installed as illustrated in the section titled “4XTMF Transmitter Module Installation” on page 55 and as outlined in Figure C.3, “Municipal Box Connected to 4XTMF Transmitter Module,” on page 190.

NFPA 72 Proprietary Fire Alarm System

FACP Alarm, Trouble and Supervisory contacts connected to Transmitter(s). See Figure C.5, “Proprietary Protective Signaling System,” on page 192, for installation instructions for this unit.

NFPA Signaling Systems for Central Station Service (Protected Premises Unit)/Remote Station

The following figure illustrates an example of Central Station/Remote Station Reporting using a 411UDAC. The relay contacts from the FACP may be used to trip any dialer UL listed for Central Station/Remote Station Services.

Notes:

1. Reference the 411UDAC Manual for additional information
2. Program the 411UDAC for slave operation
3. The FACP must be programmed for AC Loss Reporting Delay This prevents the transmission of a trouble on the loss of AC power

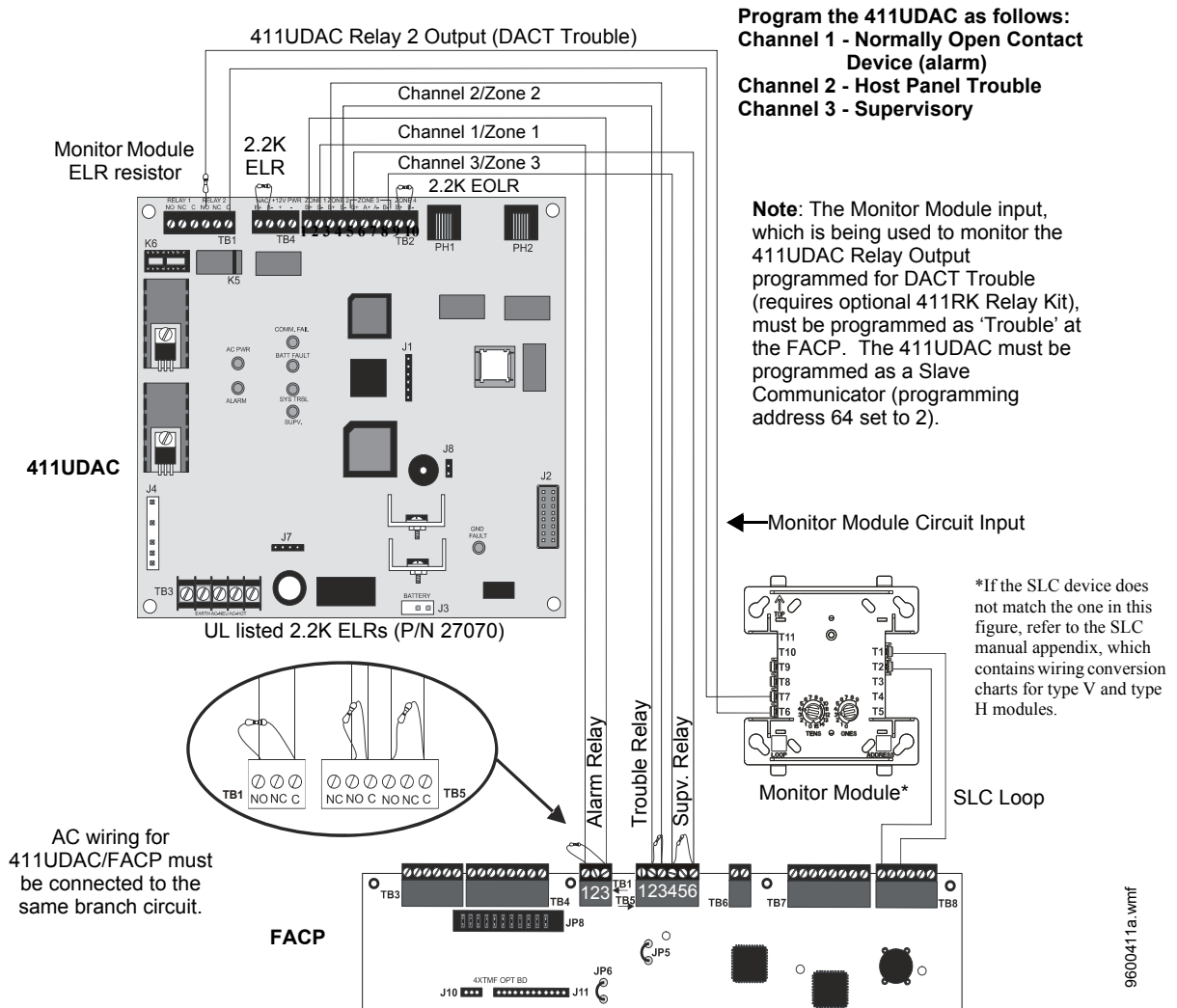

Figure C.1 Central Station Service Using 411UDAC

	411UDAC	FACP
Alarm	TB2-1	TB1-3
	TB2-2	TB1-1
Trouble	TB2-3	TB5-3
	TB2-4	TB5-2
Supervisory	TB2-5	TB5-6
	TB2-8	TB5-4

Table C.1 411UDAC Connections to FACP

The following figure illustrates an example of Central Station/Remote Station Reporting using a 411UD. The relay contacts from the FACP may be used to trip any dialer UL listed for Central Station/Remote Station Reporting Services.

Note: The Monitor Module input, which is being used to monitor the 411UD Relay #2 Output (programmed for DACT Trouble), must be programmed as 'Trouble' at FACP.

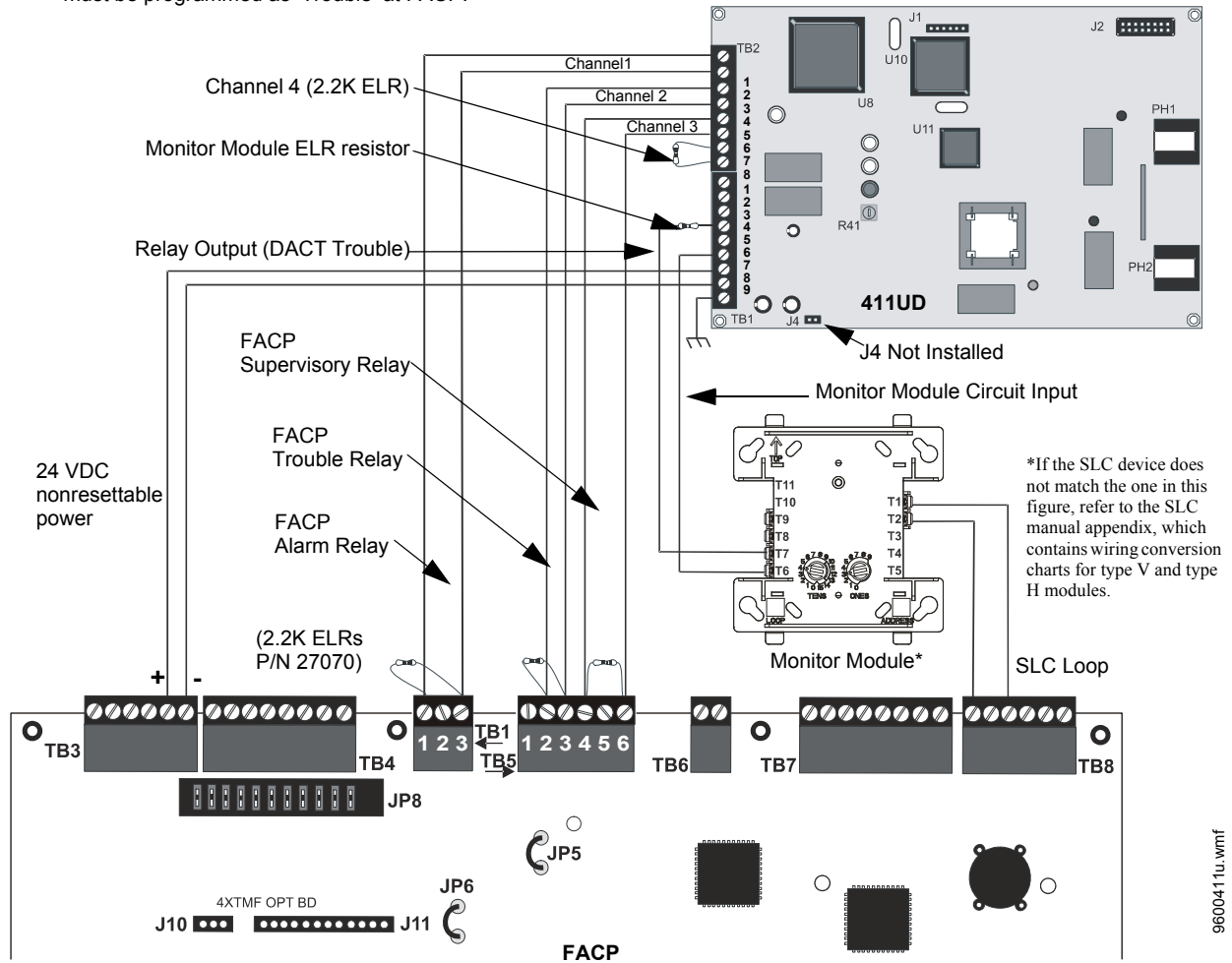

Figure C.2 FACP Connection to 411UD

	411UD	FACP
Alarm	TB2-1	TB1-1
	TB2-2	TB1-3
Trouble	TB2-3	TB5-2
	TB2-4	TB5-3
Supervisory	TB2-5	TB5-4
	TB2-6	TB5-6

Table C.2 411-UD Connections to FACP

NFPA 72 Auxiliary Fire Alarm System

All connections are power-limited and supervised. This application is not suitable for separate transmission of sprinkler supervisory or trouble conditions.

Notes:

1. 3 ohms maximum loop resistance allowed for wiring from control panel to Municipal Box.
2. Cut JP6 on the FACP main circuit board to supervise placement of 4XTMF module and circuit.
3. Cut JP5 on the FACP main circuit board to enable FACP Supervisory relay.
4. Refer to “4XTMF Transmitter Module Installation” on page 55 for detailed information.

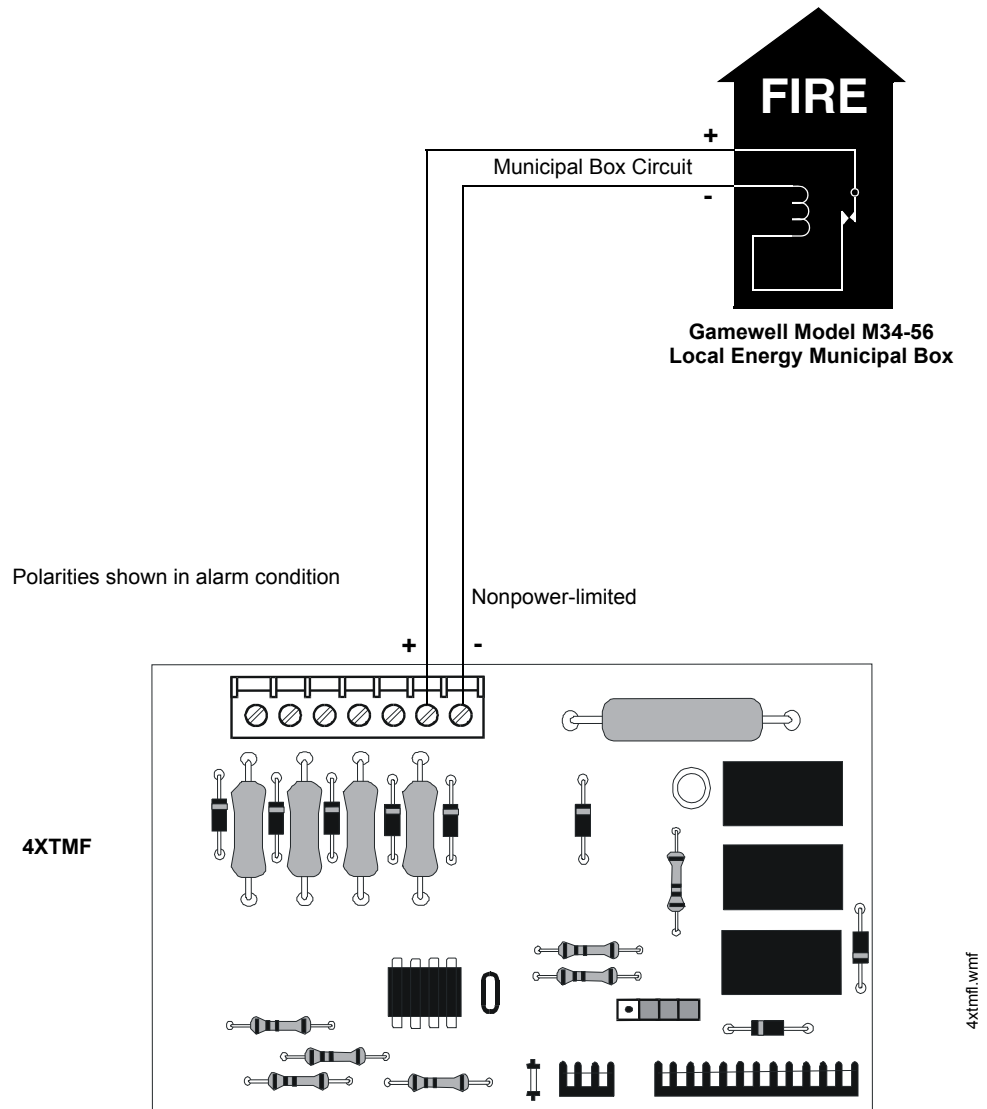

Figure C.3 Municipal Box Connected to 4XTMF Transmitter Module

NFPA 72 Remote Station Protective Signaling System

Notes:

1. Cut Jumper JP6 on the FACP main circuit board to supervise placement of the 4XTMF module.
2. Refer to “4XTMF Transmitter Module Installation” on page 55 for detailed information.

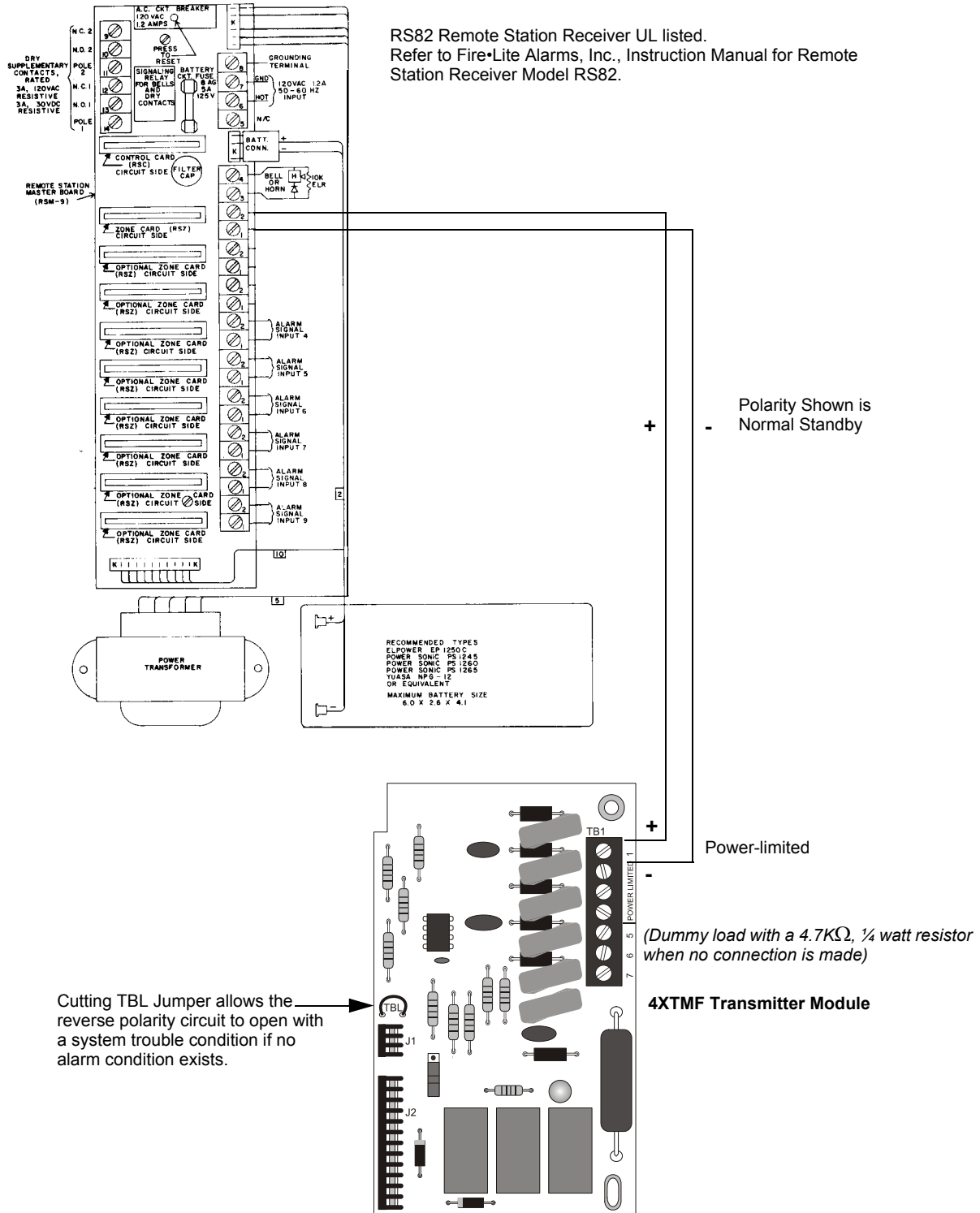

Figure C.4 Remote Station Connection Using 4XTMF Module

NFPA 72 Proprietary Protective Signaling Systems

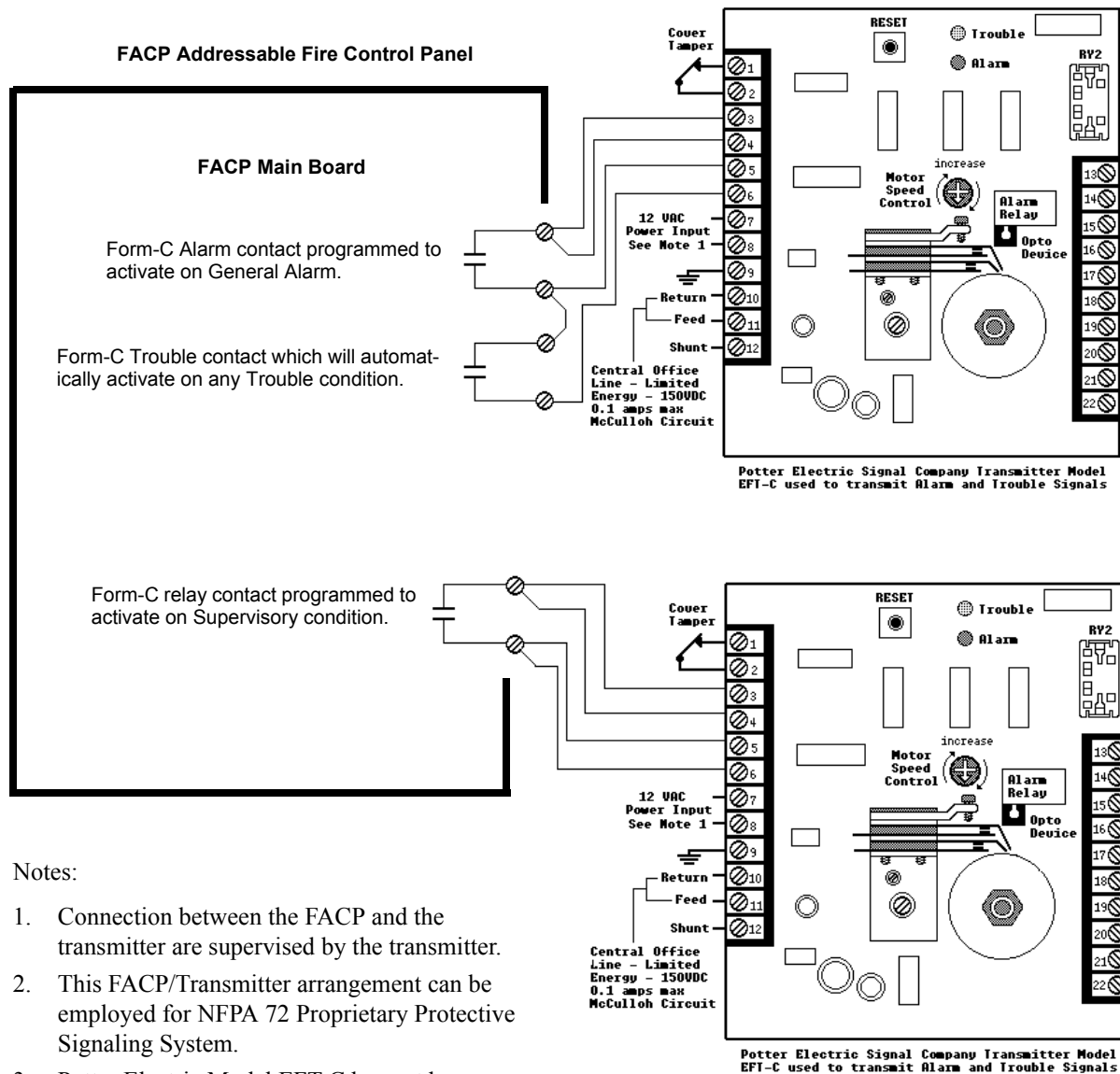

Figure C.5 Proprietary Protective Signaling System

C.1 Central Station/Remote Station Transmitter: Connection to FACP Dry Contacts

The dry contacts of the FACP programmable relays can be used to trip a UL-864 Listed Central Station/Remote Station Transmitter. The FACP contacts must be supervised by the Central Station/Remote Station Transmitter module using End-of-Line Resistors (ELRs) with a value determined by the Transmitter manufacturer. Power is also provided by the Central Station/Remote Station Transmitter manufacturer. Refer to the Central Station/Remote Station Transmitter manufacturer's manual for details.

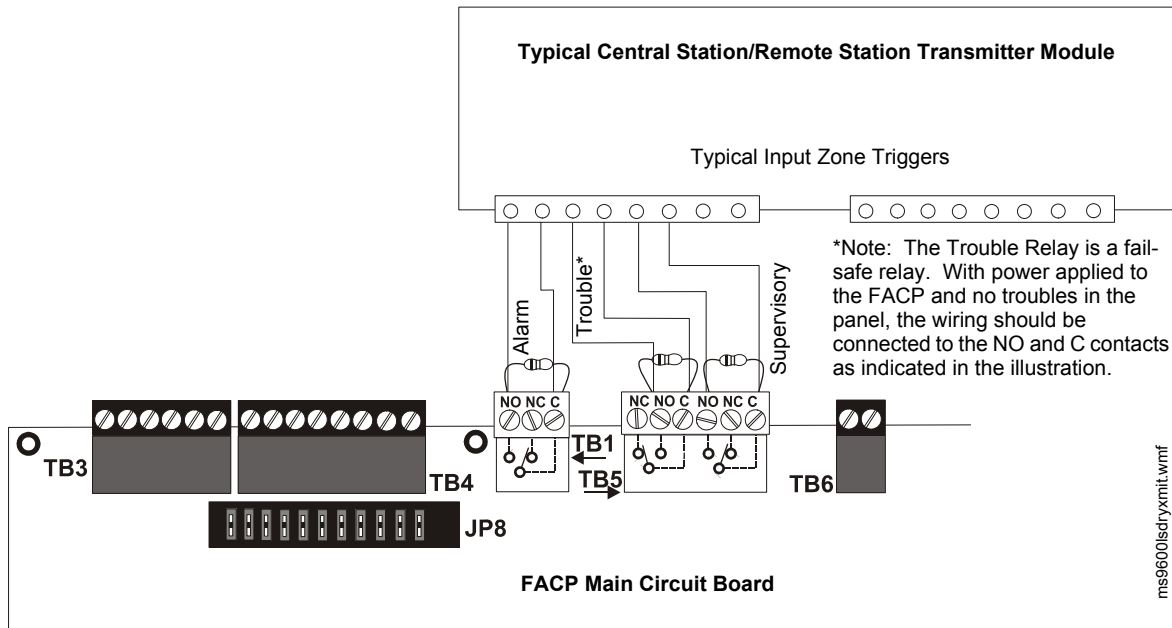
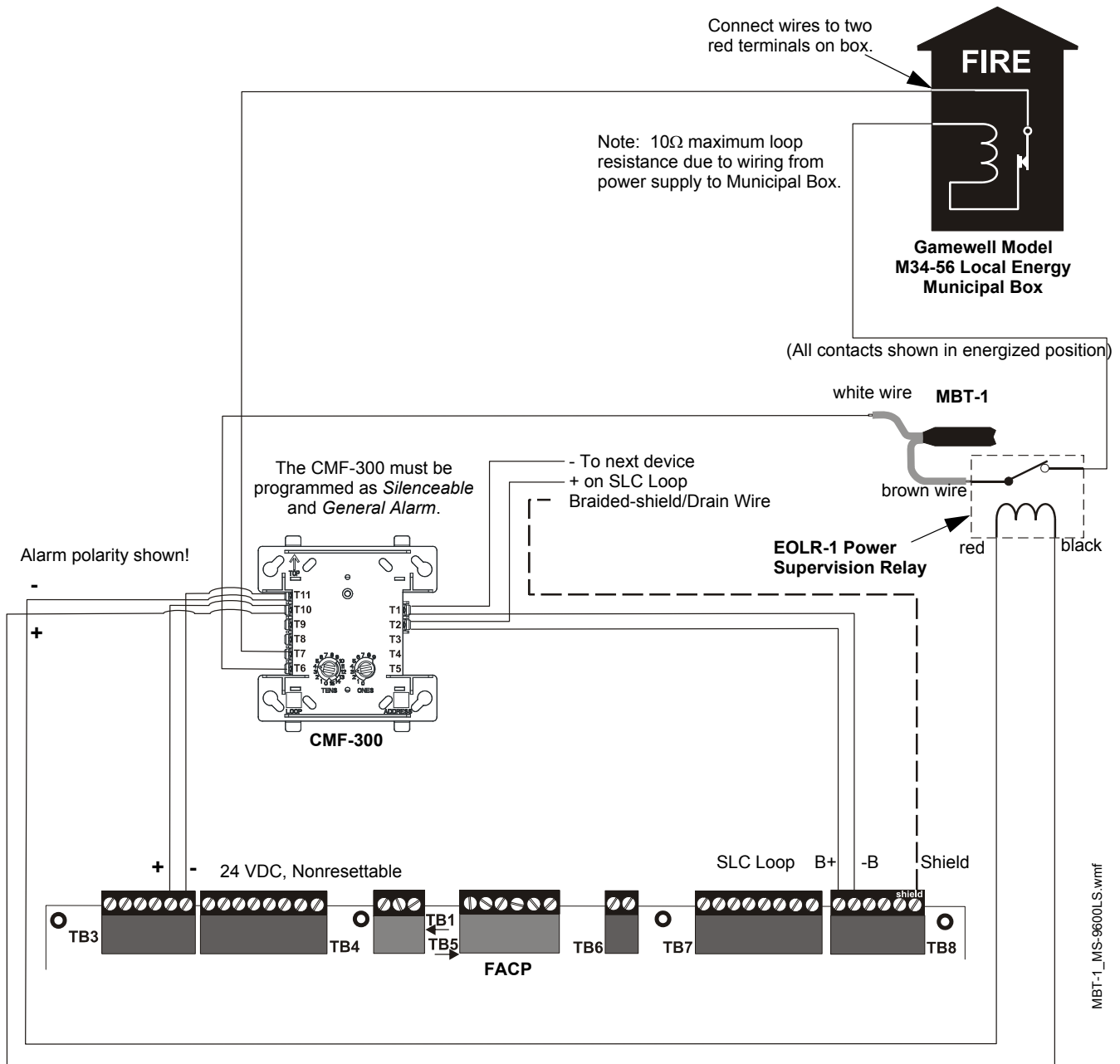

Figure C.6 FACP Dry Contacts Connection to Central Station/Remote Station Transmitter

C.2 MBT-1 Municipal Box Trip - Silenceable

The following figure illustrates the connection of the MBT-1 (Municipal Box Trip) between the FACP and a Local Energy Municipal Box. The use of an addressable control module programmed for *General Alarm* and *Silenceable* allows silencing of the Municipal Box without resetting the panel or box.



Appendix D: FACP with Keltron

The following figure illustrates the connections between the FACP and Keltron Receiver/Transmitter.



CAUTION: POSSIBLE EQUIPMENT DAMAGE

FOR REASONS OF WIRING DIAGRAM CLARITY, TERMINAL DESIGNATIONS OF KELTRON MODULES ARE NOT SHOWN IN ACTUAL ORDER. FOLLOW KELTRON MANUAL AND MODULE MARKINGS FOR EXACT TERMINAL LOCATIONS TO PREVENT SEVERE MODULE DAMAGE!

IMPORTANT! All connections between the FACP and Keltron modules must be made within 20 feet and enclosed within conduit or equivalently protected against mechanical injury.

Keltron 95M3158 TTM-RPS

1. Terminals 7 and 8: Remote station alarm/trouble inputs.
2. Terminals 9 and 10: Sprinkler supervisory input.

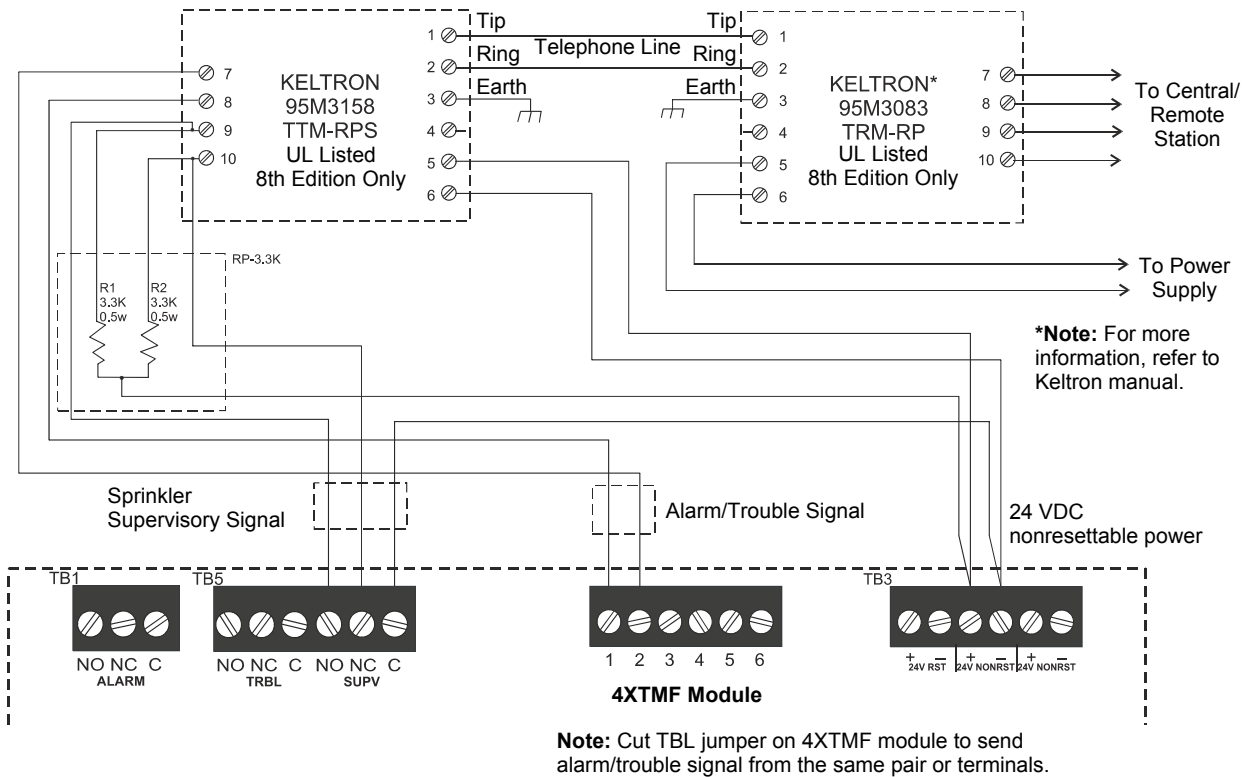

Fire Alarm Control Panel
(terminal blocks are not shown in their actual positions in order to clarify wiring connections)

Figure D.1 Wiring to Keltron Printer

Appendix E: Wire Requirements

T-tapping of the SLC loop wiring is allowed for 2-wire (Style 4) configurations. The total resistance of any branch cannot exceed 40 ohms. The total wire length of all branches cannot exceed 10,000 feet (3,000 m).

Connecting external system accessories to the FACP main circuits must be carefully considered to ensure proper operation. It is important to use the correct type of wire, wire gauge and wire run length for each FACP circuit. Reference the chart below to specify wire requirements and limitations for each FACP circuit.

Note:

1. If the SLC loop is to be run in conduit with Notification Appliance Circuits, the risk of encountering problems can be greatly reduced by exclusively employing electronic sounders instead of more electronically noisy notification appliances such as electromechanical bells or horns.
2. If two SLC loops are to be installed in conduit, each loop must be installed in separate conduit.
3. The SLC can be programmed to operate in LiteSpeed mode (factory default setting) for a quicker device response time. While shielded wire is not required in LiteSpeed mode, it is recommended that all SLC wiring be twisted-pair to minimize the effects of electrical interference. Use the following table to determine the specific wiring requirements for the SLC when unshielded wire is used:

CIRCUIT CONNECTIONS		WIRE REQUIREMENTS		
Circuit Type	Circuit Function	Wire Type and Limitations	Recommended Max. Distance Feet (meters)	Wire Gauge and Compatible Brands
SLC loop (power-limited)	Connects to Addressable Devices	Twisted, shielded pair 40 ohms maximum per length of Style 6 and 7 loops. 40 ohms per branch maximum for Style 4 loops	10,000 (3,000 m)	12 AWG (3.25 mm ²): Genesis 4410, Signal 98230, Belden 9583, WPW999 14 AWG (2.00 mm ²): Genesis 4408 & 4608 Signal 98430, Belden 9581, WPW995 16 AWG (1.30 mm ²): Genesis 4406 & 4606 Signal 98630, Belden 9575, WPW991 <u>Direct Burial Cable</u> Isotec NP713110VNQ-S 18 AWG (0.75 mm ²): Genesis 4402 & 4602 Signal 98300, Belden 9574, WPW975 <u>Direct Burial Cable</u> Isotec NP714110VNQ-S
			8,000 (2,400 m)	
	4,875 (1,450 m)			
	3,225 (980 m)			
LITESPEED MODE	Twisted, unshielded pair 40 ohms maximum per length of Style 6 and 7 loops. 40 ohms per branch maximum for Style 4 loops	10,000 (3,000 m)	12 AWG (3.25 mm ²): Belden 5020UL & 6020UL, Genesis WG-4315 & WG-4515 14 AWG (2.00 mm ²): Belden 5120UL & 6120UL, Genesis WG-4313 & WG-4513 16 AWG (1.30 mm ²): Belden 5220UL & 6220UL, Genesis WG-4311 & WG-4511 18 AWG (0.75 mm ²): Belden 5320UL & 6320UL, Genesis WG-4306 & WG-4506	
		8,000 (2,400 m)		
		4,875 (1,450 m)		
		Untwisted, unshielded pair ¹	3,000 (900 m)	12-18 AWG (3.25 - 0.75 mm ²) using listed wire
ACS-BUS (EIA-485) (power-limited)	Connects to annunciator modules	Twisted pair with characteristic impedance of 120 ohms	6,000 (1,800 m)	12 AWG (3.25 mm ²)
ANN-BUS (EIA-485) (Power-limited)	Connects to annunciator modules	Twisted pair	6,000 (1,800 m)	Refer to "ANN-BUS Wiring" on page 23 for wire requirements.
EIA-232 (power-limited)	connects to remote PC computer	Twisted, shielded pair	50 (15 m)	18 AWG (0.75 mm ²) minimum
MMF-300 and MMF-301 (power-limited)	Initiating Device Circuit	Maximum loop wire resistance is 40 ohms for the MMF-300 and 20 ohms for the MMF-301	2,500 (760 m)	12-18 AWG (3.25 - 0.75 mm ²)
MMF-302 (power-limited)	Initiating Device Circuit	No more than a 2.4 volt drop allowed at end of circuit. Maximum loop wire resistance is 25 ohms	2,500 (760 m)	12-18 AWG (3.25 - 0.75 mm ²)
CMF-300 (power-limited)	Notification Appliance Circuit	In alarm, no more than a 1.2 volt drop allowed at end of circuit	Distance limitation set by 1.2 volt maximum line drop	12-18 AWG (3.25 - 0.75 mm ²)

Table E.1 FACP Wire Specifications

1 When using untwisted, unshielded wire, full conduit is recommended for optimum EMI/RFI protection.

E.1 NAC Wiring

The following table lists NAC wiring requirements for the FACP.

NAC Load (Amps)	Max. allowable total loop resistance (ohms)	CLASS-B Max. allowable wire pair length (feet)				CLASS-A Max. allowable wire pair length (feet)			
		AWG 12 solid	AWG 14 solid	AWG 16 solid	AWG 18 solid	AWG 12 solid	AWG 14 solid	AWG 16 solid	AWG 18 solid
0.25	12.72	3295	2072	1301	819	1648	1036	650	409
0.5	6.36	1648	1036	650	409	824	518	325	205
0.75	4.24	1098	691	434	273	549	345	217	136
1	3.18	824	518	325	205	412	259	163	102
1.25	2.54	659	414	260	164	330	207	130	82
1.5	2.12	549	345	217	136	275	173	108	68
1.75	1.82	471	296	186	117	235	148	93	58
2	1.59	412	259	163	102	206	129	81	51
2.25	1.41	366	230	145	91	183	115	72	45
2.5	1.27	330	207	130	82	165	104	65	41

Table E.2 NAC Wiring Requirements for FACP

Notes:

1. Calculations are based on Direct-Current Resistance data for **uncoated copper wire**, per National Electrical Code (2005 Edition) Table 8, Conductor Properties.

Appendix F: HVAC Control

The FACP can be programmed to shut down a building's HVAC fans in the event of a fire. The fans cannot be restarted until the fire alarm condition has been cleared and the FACP has been reset to a normal (non-alarm) condition.

IMPORTANT! This HVAC feature is not to be used for smoke control. It is only designed to shut down fans during a fire alarm condition.

F.1 Control Module Operation

F.1.1 HVAC SHUTDN

The **HVAC SHUTDN** type code can be assigned to any addressable control relay module for the purpose of shutting down HVAC fans during a fire alarm condition. Devices connected to a module with this type code are unsupervised. To program this feature in the FACP:

- Program the **HVAC SHUTDN** type code to the control module which will be used to shut down the fans (refer to *Type* under the section titled “Edit Module Screen for Control Modules” on page 88).
- Program the control module to a software zone and program alarm input devices which, when activated are to cause fan shutdown, to the same software zone (refer to *Zone Assignment* under the section titled “Edit Module Screen for Control Modules” on page 88).
- Monitor the control module using an addressable monitor module programmed for *Trouble Monitor*. The monitor module label should be programmed to indicate HVAC SHUTDOWN. When the control module is active (HVAC SHUTDN), the monitor module will indicate a trouble condition at the FACP and the display should indicate the HVAC is shut down.

Once activated, the HVAC SHUTDN control module remains activated, even if the FACP is silenced or reset. After the alarm condition on the FACP has been cleared and the panel reset, the HVAC SHUTDN control module remains activated and the fans remain off. The monitor module programmed for *Trouble Monitor* which is being used to supervise the control module, will indicate a trouble condition at the control panel and the LCD should display that the HVAC is shut down. The fans can only be restarted when the HVAC SHUTDN control module is deactivated by the HVAC RESTART module.

F.2 Monitor Module Operation

F.2.1 HVAC RESTART

The **HVAC RESTART** type code can be assigned to any addressable monitor module for the purpose of resetting (deactivating) the HVAC SHUTDN control module and turning the fans back on. The **HVAC RESTART** monitor module acts globally throughout the FACP system and therefore is not programmed to a particular software zone. To program this feature in the FACP:

- Program the **HVAC RESTART** type code to the monitor module which will be used to deactivate the HVAC SHUTDN control module and restart the fans (refer to *Type Monitor* under the section titled “Edit Module Screen for Monitor Module” on page 79).

The HVAC RESTART monitor module does not latch when activated. Pressing a switch connected to the monitor module will deactivate the HVAC SHUTDN control relay module *only if there are no alarm conditions*. The HVAC SHUTDN control relay module can be deactivated if trouble conditions exist on the FACP.

F.2.2 HVAC OVRRIDE

The **HVAC OVRRIDE** type code can be assigned to any addressable monitor module for the purpose of overriding or preventing the HVAC SHUTDN control modules from activating. The **HVAC OVRRIDE** monitor module acts globally throughout the FACP system and therefore is not programmed to a particular software zone. To program this feature in the FACP:

- Program the **HVAC OVRRIDE** type code to the monitor module which will be used to override the HVAC SHUTDN control module and prevent the fans from turning off (refer to Type Monitor under the section titled “Edit Module Screen for Monitor Module” on page 79).

The HVAC OVRRIDE monitor module does not latch when activated. Activating a switch connected to the monitor module will override all HVAC SHUTDN control relay modules in the system, preventing the HVAC SHUTDN modules from activating and causing the FACP LCD to display an active HVAC OVRRIDE module and turn on the Supervisory LED. Releasing the switch will allow the HVAC SHUTDN control relay modules to activate with subsequent alarms, turning off the fans.

As an example, pressing the HVAC OVRRIDE switch with no alarms in the system will prevent the fans from being turned off when an alarm does occur. As long as the switch is activated, the fans will not shutdown for any alarms. If the system is still in alarm when the switch is released, the fans will not shutdown unless another alarm occurs after the switch is released.

Important! If an alarm exists in the system and HVAC Shutdown has already occurred, HVAC OVRRIDE will have no effect on the HVAC SHUTDN control relay modules. HVAC OVRRIDE will prevent HVAC Shutdown from occurring only if it is initiated prior to an alarm condition.



NOTE: Activation of the HVAC OVRRIDE module causes a supervisory event that will be communicated to the Central Station if enabled.

Appendix G: Canadian Application

- The MS-9600LSC is supplied with the DP-9692 Dress Panel.
- When installing and programming the FACP, the Canadian Option must be set to **ON** prior to any other panel programming (refer to “Canadian Option” on page 113 of the Programming Section of this manual).
- ACS Series annunciators are not compatible for Canadian applications.
- The LCD-80FC annunciator can be used for optional ancillary annunciation.
- The ANN-LED annunciator must be installed in the same room as the FACP. All wiring between the FACP and ANN-LED must be in metal conduit no longer than 20 feet.
- The installer must write in the *Date of Final Assembly* on the Master Marking and Warranty Label located on the FACP backbox door.
- To comply with CAN/ULC - S559-04, the DACT-UD2 and 4XTMF must both be utilized.

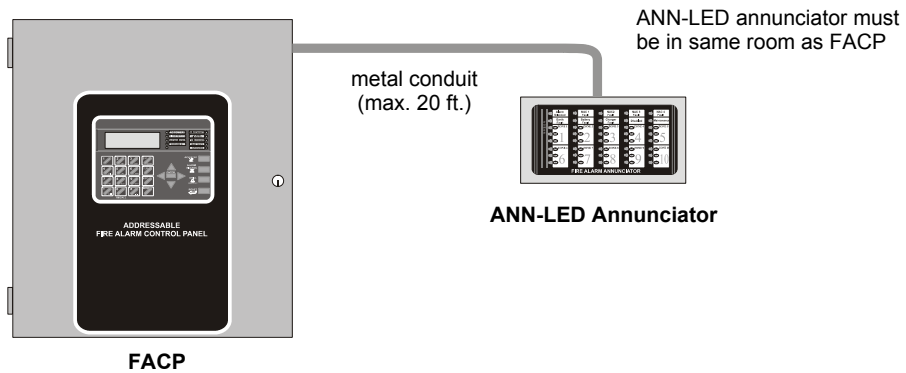

Figure G.1 FACP Minimum Configuration - Single ANN-LED Annunciator

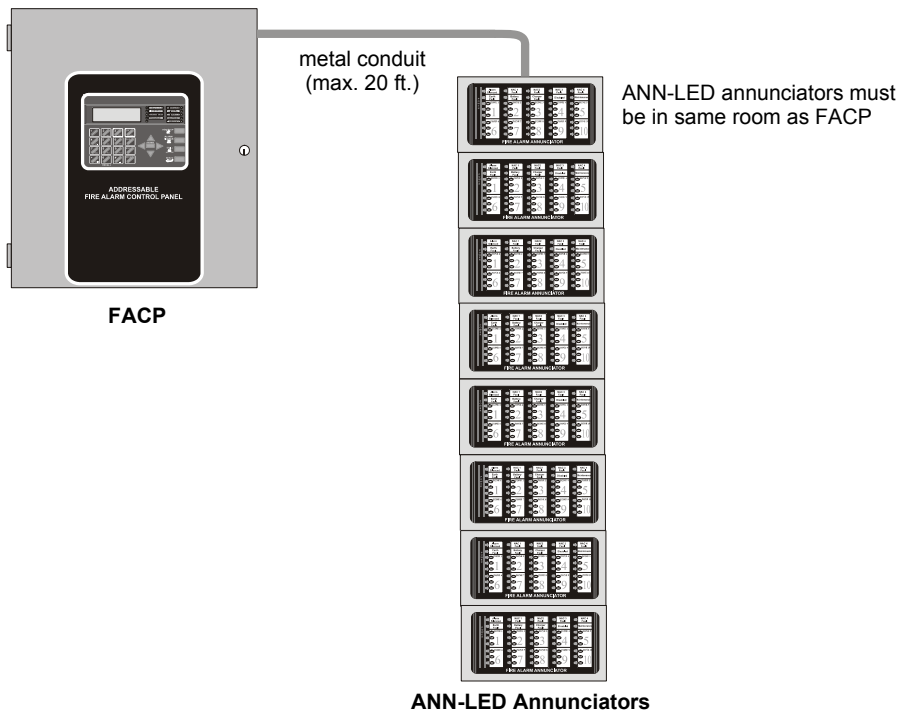

Figure G.2 FACP Maximum Configuration - Eight ANN-LED Annunciators

Index

Numerics

- 300 Series addressable devices **20**
- 4XTMF module **190, 191**
 - coil resistance **55**
 - current **55**
 - installation **55**
 - installation steps **56**
 - see also Transmitter Module **15, 21**
 - voltage **55**

A

- AC Branch Circuit
 - calculations **174**
- AC Loss Delay **106**
- AC Power **46**
 - current **15**
 - current, maximum **46**
 - voltage **15**
 - wiring **15, 46**
- Acknowledge/Step **18, 150**
- ACM LED annunciator **60**
- ACM Series
 - see also annunciator **40**
- ACM-16ATF Annunciator **40**
- ACM-32AF Annunciator **40**
- ACM-8RF **14**
 - contact rating **59**
 - see also Relay Control Module **59**
- ACS LED annunciator **14**
- add Detector **67**
- add Module **78**
- address range **20**
- addressable **13**
- addressable detectors
 - see also detectors **15**
- Addressable Device Accessories **20**
- addressable modules **20**
 - see also modules **15**
- addressing
 - annunciators **120**
 - see also device addressing **100**
 - see also module or detector addressing **20**
- Adjective
 - control module **92**
 - monitor module **85**
 - multiple entries **77**
- Adjective list **75**
- AEM-16ATF Annunciator **40**
- AEM-32AF Annunciator **40**
- Alarm **153**
- Alarm Silence **18, 150**
- alarm verification **14, 72, 157, 159**

- ANN-RLY Annunciator Module **36**
- ANN-SB80KIT Mounting Kit **28**
- annunciator **40**
 - ACM **14, 120**
 - ACM-8RF **14**
 - graphic, see also LDM Series **14, 40**
- annunciator addressing **120**
- annunciator, remote
 - see also LCD-80F **40**
- Auto Silence
 - NAC **110**
- Automatic Test Operation **156**
- Autoprogramming **15, 62, 66**
- Autosilence **14, 159**
- auxiliary DC power **47**
- Auxiliary Trouble Input **19, 57**

B

- backbox **19**
 - see also cabinet **45**
- Banner **100**
- Banner setting **101**
- battery **19**
 - cable connection **46**
 - charger **18, 22**
 - charger capacity **15**
 - charger, disable **15**
 - charger, external **22**
 - Charging Circuit **15**
 - see also secondary power **15, 46**
- battery box **22**
- baud rate **134**
- BB-55F
 - see also battery box **20, 22**

C

- cabinet **19**
 - dimensions **44, 45**
 - mounting **42**
- Calculate System Current Draw **175**
- Calculating the Battery Size **177**
- Canadian Option **100, 113**
- Central Station/Remote Station Reporting **189**
- CHG-120F
 - see also battery charger **22**
 - see also remote battery charger **15**
- CHG-75
 - see also battery charger **22**
 - see also remote battery charger **15**
- Class A **47**
- Class B **47**
 - NAC wiring **49**

Classic Loop Interface Protocol **100**
 CLIP Mode
 see also Classic Loop Interface Protocol
 100
 Clock Format **104**
 Coded Operation **157**
 Coding
 NAC **110**
 coding
 two stage operation **111**
 control buttons **150**
 control module **20**
 description display **94**
 display **88**
 edit **88**
 enable/disable **89**
 noun **93**
 noun/adjective **91, 92**
 silenceable **90**
 type **89**
 type codes **90**
 Correlations **178**
 current
 AC Power **46**
 availability **17**
 maximum **17**
 Current Draw Calculations **176**

D

DACT **134**
 DACT-UD2 **15**
 functions **52**
 installation **52**
 option module installation **52, 53**
 phone lines **54**
 see also Digital Alarm Communicator/
 Transmitter **21**
 data
 see also detector data and sensitivity **157**
 values **14**
 Data Entry
 via computer keyboard **61**
 via keypad **61**
 Date setting **103**
 Daylight Savings Time **104**
 DC power
 nonresettable **47**
 resettable **47**
 see also auxiliary DC power **47**
 Default Programming **186**
 Delete Detector **68**
 Delete Module **79**
 Description
 control module **94**
 detector label **77**
 monitor module **87**

Detector
 add **67**
 adding description **74**
 delete **68**
 edit **69**
 enable/disable **71**
 screen display **70**
 type **71**
 verification **72**
 detector data **157, 171, 172**
 acceptable range **171**
 printout **171**
 Detector Programming **67**
 device addressing **100**
 Digital Alarm Communicator/Transmitter
 see also DACT-UD2 **21**
 dimensions
 cabinet **44**
 DIRTY1 **172**
 DIRTY2 **172**
 Disable **96**
 Disable Point
 Maintenance Level **139**
 dress panel **19, 22**
 drift compensation **14, 172**
 definition **172**
 Drill **18, 150**

E

earth ground **46**
 edit
 control module **88**
 detector **69**
 detector screens **70**
 module, monitor **79**
 EIA-232 **59**
 for PC/Printer connection **16**
 see also Printer/PC interface **14**
 EIA-485
 for ACS annunciators **16**
 for LCD-80F **16**
 Enable **95**
 Enable/Disable
 control module **89**
 detector **71**
 module, monitor **81**
 End-of-Line Resistor Assembly **20**
 Enter key **64**
 Erase History **115**
 exiting
 programming **63, 64**
 Read Status **63, 64**
 Expander Module **57**
 see also SLC-2 **21**

F

FACP
 see also Fire Alarm Control Panel **13**
 Features **13**
 Fire Alarm Control Panel
 see also FACP **13**
 Form-C relay **19, 47, 59**

G

general alarm zone **84**
 see also zone Z00 **74**
 ground fault **59**

H

Hazard Condition **155**
 History **115**
 erase **115**
 Maintenance Level **140**
 view events **115**
 History file **14**
 HVAC Control **198**
 HVAC OVERRIDE **199**
 HVAC RESTART **198**
 HVAC SHUTDN **198**

I

Indicators **17**
 Installation **42**
 intelligent **13**
 Inventory **13**
 INVREP **172**

K

Key Panel **18**
 function keys **18**
 service/program keys **18**
 keyboard and keypad **61**
 Keypad/Display
 removal and installation **51**

L

lamp test **18**
 LCD display **14, 17**
 LCD-80F annunciator **14, 40**
 LDM Series annunciator **40**
 LDM-32 Graphic Annunciator **14**
 LED
 AC Power **150**
 Alarm Silenced **151**
 Battery **151**
 Disabled **151**
 Fire Alarm **150**
 Ground **151**

Maintenance **151**
 see also Indicators **17**
 Supervisory **151**
 Trouble **151**

LED annunciator **40**
 Local Energy Municipal Box Service **55**
 Local Programming **62**
 Loop Setup **99**

M

main circuit, mounting **42**
 Maintenance Alert **14, 156**
 levels **172**
 maintenance alert **172**
 Maintenance Program Level 2 **63, 138**
 Manual programming **62**
 Master Program Level 1 **63, 65**
 Medical Alert **156**
 Mode key **64**
 Module
 add **78**
 addressing **20**
 delete **79**
 edit monitor **79**
 enable/disable **81**
 see also addressable modules **20**
 Module Programming **78**
 Monitor module **20**
 adjective **85**
 enable/disable **81**
 noun **86**
 noun/adjective **84**
 type **82**
 type action **83**
 Type list **82**
 type selection **83**
 Mounting
 cabinet **42**
 main circuit board **42**
 municipal box transmitter
 see also 4XTMF module **55**

N

NAC **15, 19, 107, 157**
 Auto Silence **110**
 coded **157**
 coding **110**
 current **16**
 End-of-Line Resistor **16**
 power **14**
 see also Notification Appliance Circuit **14, 47**
 silence inhibit **112**
 silenceable **109**
 Style configuration **48**
 Style Y wiring diagram **49**

- synchronized **157**
 - voltage drop **15**
 - voltage, operating **15**
 - wiring Style **47**
 - NAC enable/disable **108**
 - NAC options **100**
 - NAC type **109**
 - NACKEY card **48**
 - N-ELR Mounting Plate **21**
 - NFPA 72 Auxiliary Fire Alarm System **187, 190**
 - NFPA 72 Central Station Service (Protected Premises Unit) or Remote Station Service **187**
 - NFPA 72 Proprietary Fire Alarm System **187**
 - NFPA 72 Proprietary Protective Signaling Systems **192**
 - NFPA 72 Remote Station Protective Signaling System **191**
 - NFPA Battery Requirements **177**
 - NFPA Signaling Systems for Central Station Service (Protected Premises Unit)/Remote Station **188**
 - NFPA Standard **187**
 - Nonresettable Power **18, 47**
 - current **16, 47**
 - nonsilenceable
 - waterflow **114, 148**
 - nonsilenceable waterflow **98**
 - normal display **62, 151**
 - Notification Appliance Circuit **15, 107**
 - see also NAC **14, 47**
 - Noun
 - monitor module **86**
 - multiple entries **77**
 - Noun list **76**
 - Noun/Adjective **74, 76**
 - control module **91**
 - monitor module **84**
- O**
- Operating Instructions **150**
 - Operation
 - alarm **153**
 - disable/enable **156**
 - hazard condition **155**
 - medical alert **156**
 - NAC **157**
 - normal **151**
 - process monitor **155**
 - programmed zone **156**
 - supervisory **154**
 - trouble **152**
 - waterflow **156**
 - Option Modules **21, 51, 117**
 - annunciators/UDACT **118**
 - Printer/PC **134**
 - Options **13**
 - Output Circuits **18**
- P**
- PAS **72, 96, 158**
 - see also Positive Alarm Sequence **14, 72**
 - PAS BYPASS **159**
 - PAS timer **105**
 - Password **15, 63**
 - change **135**
 - Maintenance Level 2 **64, 138**
 - Master Level 1 **64**
 - PC (personal computer)
 - configuration **59**
 - connection **58**
 - ground fault **59**
 - Phone Line 2
 - supervision **169**
 - phone lines
 - DACT installation **54**
 - Piezo
 - see also sounder **18**
 - Point Program **67**
 - Positive Alarm Sequence **72, 158**
 - see also PAS **14**
 - power
 - NAC **14**
 - nonresettable **16**
 - resettable **89**
 - resettable smoke **16**
 - power supply calculations **174**
 - power-limited
 - relay connections **47**
 - power-limited wiring requirements **50**
 - Power-up
 - first time **63**
 - Pre-signal **14, 73, 96**
 - function **158**
 - selection **84**
 - Pre-signal Delay timer **105**
 - primary power
 - see also AC Power **46**
 - printer
 - baud rate **134**
 - configuration **59**
 - connection **58**
 - ground fault **59**
 - setup **59**
 - Printer/PC interface **14**
 - Process Monitor **155**
 - PROCMON AR **113**
 - Program
 - check **137**
 - check correlations **137**
 - clear **136**
 - Program Check
 - Maintenance Level **141**

program keys
 see also Key Panel **18**

Programming **61, 62**
 autoprogramming **62**
 exiting **63**
 factory default **186**
 Level 1 **63**
 Level 2 **63**
 manual **62**
 Master Level 1 **65**
 modules **78**
 off-line computer **62**
 via computer keyboard **61**
 via panel keypad **61**

Programming Levels **63**

Programming Screens **63**

Programming Sheet **180, 181, 182, 183, 185**

Programming Utility
 see also PS-Tools **21**

PRT/PK-CABLE
 for PC/Printer connection **59**

PS-Tools Programming Utility **21**

R

Read Status **62, 161**
 annunciators **167, 169**
 exiting **63**
 history **167**
 NAC **166**
 power **164**
 Print **171**
 printer/PC **170**
 program check **167**
 relay **166**
 system point **162**
 Time-Date **173**
 timers **165**
 trouble reminder **165**
 zones **163**

Real-Time Clock **157**

Recall/Increment Function **77, 87, 94**

Relay **16, 19, 47, 112**
 connections **47**
 contact rating **16, 19, 47**
 fixed **47**
 Form-C **16, 112**
 programmable **14, 19, 47**
 programming **113**
 selections **113**
 trouble **14, 19, 47**

Relay Control Module
 see also ACM-8RF **59**

Relay options **100**

Remote Programming **62**

Remote Station Service **56**

remote switch functions **14**

Reset **18, 150**

Resettable Power **18, 47, 89**
 current **47**
 see also Smoke Detector Power **16**

S

Secondary Power Requirements **177**

sensitivity **157, 172**
 see also smoke detector sensitivity **157**

Signal rate **14**

Signaling Line Circuit
 see also SLC **15**

Silence Inhibit **14, 112, 159**

silenceable
 control module **90**
 NAC **109**
 waterflow **98, 100, 114**

Silenceable Alarm Relay **113**

silenceable circuits
 synchronized signals **109**

Silenceable waterflow **148**

SLC **13, 15, 18**
 current **15**
 reference manual **15**
 resistance **15**
 see also Signaling Line Circuit **13**
 Style **18**
 voltage **15**
 wiring length **15**

SLC Loop Protocol **100**

SLC loop selection **67**

SLC Style **99**

SLC-2 **57**
 installation **57**
 wiring **58**

SLC-2 Expander Module **21**

smoke detector
 chamber reading **171**
 data **157, 171**
 sensitivity **157**

Smoke Detector Power
 current **16**
 smoke detector sensitivity **14**

Software Zones **14, 178**

sounder **18**

Specifications **15**

strobe synchronization **14**

Style **13**

Style Y **47**
 NAC wiring **49**
 NC configuration **48**

Style Z **47**
 NAC configuration **48**
 wiring **49**

subscreen **63**

supervise

Phone Line 2 **169**
 Supervisory **154**
 SUPERVISORY AR **113**
 sync
 programming **108**
 see also synchronization **112**
 synchronization **157, 166**
 by manufacturer **112**
 programming **112**
 see also strobe synchronization **14**
 synchronized **157**
 Synchronized Signals **157**
 and silenceable circuits **109**
 System
 Maintenance Level **143**
 System Point **162**
 System Setup **100**

T

Time and Date
 Maintenance Level **143**
 Time setting **103**
 Time-Date setting **100, 103**
 Timers **100**
 Transmitter Module **55**
 see also 4XTMF module **21**
 TR-CE trim ring **22**
 Trouble **152**
 trouble display **152**
 trouble relay **14**
 Trouble Reminder **100, 159, 165**
 trouble responses **152**
 Two Stage **96**
 two stage operation **111**
 Type
 control module **89**
 detector **71**
 monitor module **82**
 NAC **109**
 type code
 control module **90**
 supervision **157**
 verification **14**

U

UL power-limited wiring requirements
 see also power-limited and nonpower-limited **47**

V

Verification
 detector **72**
 Verify Loops **114**
 View Events **115**
 voltage

measurements **164**
 ranges **164**

W

Walktest **14, 72, 90, 116**
 audible **116**
 Maintenance Level **142**
 operation **160**
 selection **84**
 silent **116**
 waterflow
 nonsilenceable **98, 114, 148**
 silenceable **98, 100, 114, 148**
 Waterflow Delay timer **105, 106**
 Waterflow Retard Timer **159**
 Wire Requirements **196**
 wiring
 AC Power **46**
 earth ground **46**
 NAC Style Y **49**
 NAC Style Z **49**
 SLC-2 **58**
 wiring Style **13**

Z

Z00 **74, 84**
 Z97
 PAS zone **73**
 Z98 **73**
 Zone 97 **96**
 Zone 98 **96**
 Zone Assignment **73, 84, 112**
 control module **90**
 Zone Setup **95**
 Maintenance Level **144**
 zone type **98, 147**
 list **98, 148**
 Zone Z97 **73**
 Zone Z98
 pre-signal zone **73**
 Zones **163, 178**
 see also software zones **14**
 Zones Disabled **97, 147**
 Zones Enabled **97, 146**
 Zones Installed **97, 146**
 zones per device **73**

Manufacturer Warranties and Limitation of Liability

Manufacturer Warranties. Subject to the limitations set forth herein, Manufacturer warrants that the Products manufactured by it in its Northford, Connecticut facility and sold by it to its authorized Distributors shall be free, under normal use and service, from defects in material and workmanship for a period of thirty six months (36) months from the date of manufacture (effective Jan. 1, 2009). The Products manufactured and sold by Manufacturer are date stamped at the time of production. Manufacturer does not warrant Products that are not manufactured by it in its Northford, Connecticut facility but assigns to its Distributor, to the extent possible, any warranty offered by the manufacturer of such product. This warranty shall be void if a Product is altered, serviced or repaired by anyone other than Manufacturer or its authorized Distributors. This warranty shall also be void if there is a failure to maintain the Products and the systems in which they operate in proper working conditions.

MANUFACTURER MAKES NO FURTHER WARRANTIES, AND DISCLAIMS ANY AND ALL OTHER WARRANTIES, EITHER EXPRESSED OR IMPLIED, WITH RESPECT TO THE PRODUCTS, TRADEMARKS, PROGRAMS AND SERVICES RENDERED BY MANUFACTURER INCLUDING WITHOUT LIMITATION, INFRINGEMENT, TITLE, MERCHANTABILITY, OR FITNESS FOR ANY PARTICULAR PURPOSE. MANUFACTURER SHALL NOT BE LIABLE FOR ANY PERSONAL INJURY OR DEATH WHICH MAY ARISE IN THE COURSE OF, OR AS A RESULT OF, PERSONAL, COMMERCIAL OR INDUSTRIAL USES OF ITS PRODUCTS.

This document constitutes the only warranty made by Manufacturer with respect to its products and replaces all previous warranties and is the only warranty made by Manufacturer. No increase or alteration, written or verbal, of the obligation of this warranty is authorized. Manufacturer does not represent that its products will prevent any loss by fire or otherwise.

Warranty Claims. Manufacturer shall replace or repair, at Manufacturer's discretion, each part returned by its authorized Distributor and acknowledged by Manufacturer to be defective, provided that such part shall have been returned to Manufacturer with all charges prepaid and the authorized Distributor has completed Manufacturer's Return Material Authorization form. The replacement part shall come from Manufacturer's stock and may be new or refurbished. THE FOREGOING IS DISTRIBUTOR'S SOLE AND EXCLUSIVE REMEDY IN THE EVENT OF A WARRANTY CLAIM.

Warn-HL-08-2009.fm



World Headquarters
1 Firelite Place
Northford, CT 06472-1653 USA
203-484-7161
fax 203-484-7118

www.firelite.com



Free Manuals Download Website

<http://myh66.com>

<http://usermanuals.us>

<http://www.somanuals.com>

<http://www.4manuals.cc>

<http://www.manual-lib.com>

<http://www.404manual.com>

<http://www.luxmanual.com>

<http://aubethermostatmanual.com>

Golf course search by state

<http://golfingnear.com>

Email search by domain

<http://emailbydomain.com>

Auto manuals search

<http://auto.somanuals.com>

TV manuals search

<http://tv.somanuals.com>