

# INSTRUCTIONS FOR C1550, 1551, 1553, 1554 and C1552, C1555 SASH SETS



## ⚠️ WARNING

- Failure to follow the SE guidelines will result in serious personal injury.
- ALWAYS WEAR ANSI APPROVED EYE AND EAR PROTECTION WHEN USING THIS BIT.
- The use of a router table is strongly recommended.
- Never feed lumber with the rotation of the bit.
- Follow the safety guidelines set forth by the manufacturer of the router and router table.

## ⚠️ CAUTION

These router bits have sharp edges. Use care while removing the waxy protective coating. Never turn on the router with the protective coating still on the bit.

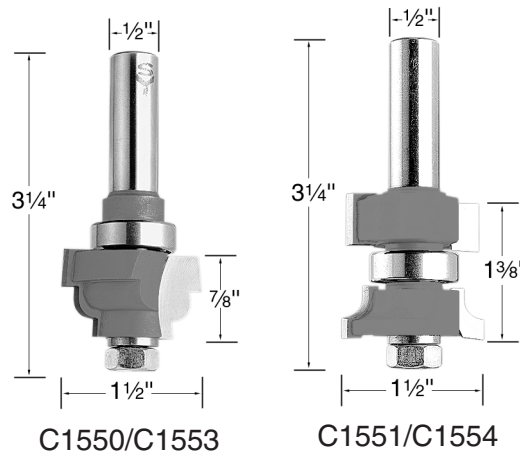

Designed specifically for architectural window construction, the Model C1550-C1554 Window Sash Sets offer excellent quality for creating beaded and ogee window trim stock. The C1550/C1551 (also sold as C1552) combination produces a bead style finish. The C1553/C1554 (also sold as

C1552) combination produces the classic Ogee finish. Fitted with precision guide bearings, these bits are capable of being used with a hand held or table mounted router. Using a table mounted router will give best results. For maximum operating efficiency, a router rated at 1 horsepower or larger is recommended. The maximum frame thickness: 1 3/8".

**Note:** These instructions and drawings are intended for explanation and clarification purposes only as they relate to this particular router bit. Apply all safety rules and measures pertaining to router operations and your specific operation. Refer to the owner's manual supplied with your router and router table for specific warnings and instructions before proceeding with equipment operations.

## ⚠️ WARNING

- Unplug router before installing or adjusting bit.
- Keep all guards and anti-kickback devices in place.
- Double check bit to insure nut is tight and bit is tight and secure in spindle.
- Always inspect lumber and other wood materials for cracks, knots, or other imperfections that could cause bit or lumber to kick or shatter while milling.

### Step 1: Cutting Stile and Rail Edges

Make sure the router is disconnected from the power source. Install the stile and rail cutter. (C1551 or C1554.) Attach the router to your router table and adjust the height of the bit until the top of the bead is 1/16" below the top of your stile. **See Figure A.** Adjust the fence until it is flush with the bearing. (The bearing can be used without the fence when you are cutting non-linear shapes such as a curved arch door rail, however a starting pin should be employed to help make safe first contact to workpiece). The workpiece must always be fed against the cutter rotation and the full depth of profile should be made in one pass to ensure a precise cut. If the window is not to be painted, a side should be chosen for appearance and marked with a pencil. Before plugging in the router, set a piece of scrap, the same size as the workpiece, on the table appearance side up. Lay the edge to be cut firmly against the fence. A hold-down device such as a featherboard should be used to keep the workpiece secured against the fence. Make a test cut to ensure that the complete profile is being cut. Adjust, if necessary, and re-test.

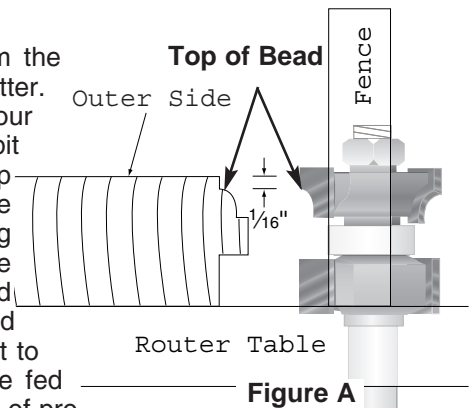

Run all of the stiles and rails for the project through the cutter before changing bits to do the rail ends.

## Step 2: Cutting Rail Ends

Unplug the router and change bits. Raise the router bit so the top of the bead is  $\frac{1}{16}$ " below the top of your stock as shown in **Figure B**. Make sure that the miter gauge used passes closely enough to the router bit to give the workpiece proper support. It is recommended an extension be applied to the miter with screws, if the miter is more than an inch from the bit. **See Figure C**. Make sure that miter and face have working clearance so they won't come in contact with bit. The miter gauge should also be checked for squareness to the miter slot and adjusted, if necessary. The fence should be moved away so the workpiece does not touch it during the cutting procedure. Run a test piece which is the same thickness as your actual rail stock. Test fit the rail to a finished stile to see how the joint looks. If the pieces do not fit together tightly, or if the front and back surfaces do not fit flush, it may be necessary to readjust. Make very small movements in the height of the router bit and test cut again.

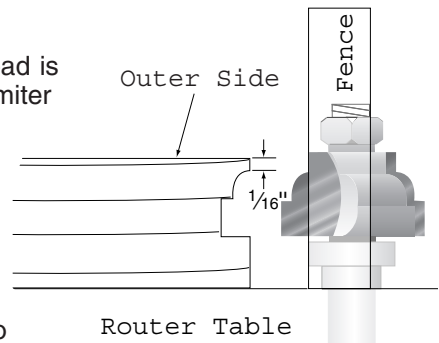

**Figure B**

When the fit is properly adjusted, make the end cuts on the rails. Double check the fit occasionally, to insure accuracy. The workpiece must always be fed against the cutter rotation and the full depth of profile should be made in one pass to ensure a precise cut. Rotate the board end for end, maintaining the face-down position and cut the other end. A clamping device may be necessary to keep the workpiece secured against the miter gauge.

The position of the profile on the workpiece and variance in material thickness will also affect alignment. It is therefore very important that test material is milled to the same thickness as the finished material to ensure an accurate setup.

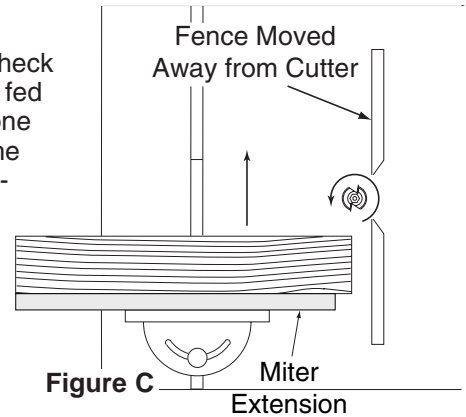

## Step 3: Assembly

The illustrations below show the typical style, rail and glass layout. Note the glazer's points which secure the pane on the back side of the frame. They can be obtained from your local hardware store along with the putty needed to finish and seal window.

Doors having more intricate designs such as arched, tombstone or curved panels should only be done when you are confident of your ability. If your project requires curved pieces then freehand routing using the bearing and starter pin will be necessary.

Remember that it is important to work with good quality material and to insure that all pieces are machined the same and that all ends and edges are cut square. Follow all recommended safety procedures and always test the setup using sample pieces.

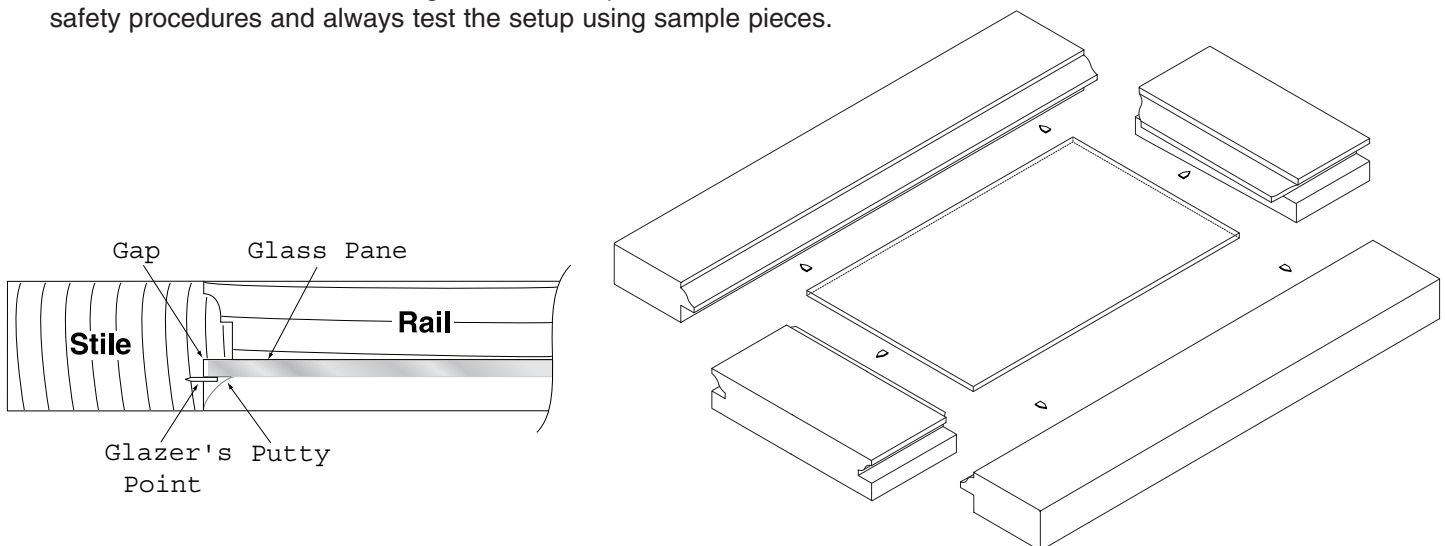

## Free Manuals Download Website

<http://myh66.com>

<http://usermanuals.us>

<http://www.somanuals.com>

<http://www.4manuals.cc>

<http://www.manual-lib.com>

<http://www.404manual.com>

<http://www.luxmanual.com>

<http://aubethermostatmanual.com>

Golf course search by state

<http://golfingnear.com>

Email search by domain

<http://emailbydomain.com>

Auto manuals search

<http://auto.somanuals.com>

TV manuals search

<http://tv.somanuals.com>