

Grizzly *Industrial, Inc.*®

TENONING JIG MODEL H7583 INSTRUCTION MANUAL

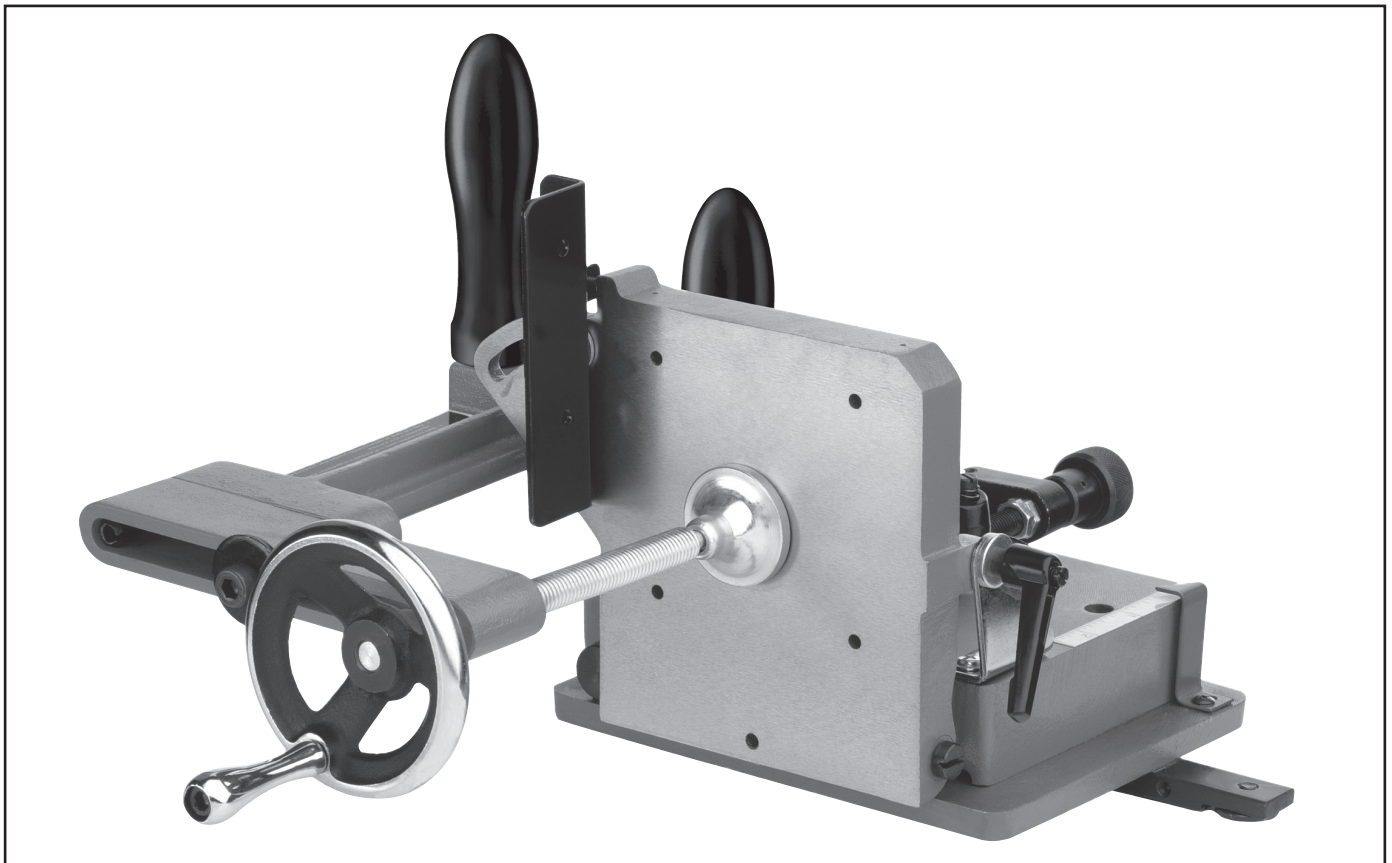

COPYRIGHT © MAY, 2005 BY GRIZZLY INDUSTRIAL, INC. REVISED DECEMBER, 2007 (JB)
**WARNING: NO PORTION OF THIS MANUAL MAY BE REPRODUCED IN ANY SHAPE
OR FORM WITHOUT THE WRITTEN APPROVAL OF GRIZZLY INDUSTRIAL, INC.**
#EW7181 PRINTED IN CHINA

WARNING

Some dust created by power sanding, sawing, grinding, drilling, and other construction activities contains chemicals known to the State of California to cause cancer, birth defects or other reproductive harm. Some examples of these chemicals are:

- Lead from lead-based paints.
- Crystalline silica from bricks, cement, and other masonry products.
- Arsenic and chromium from chemically treated lumber.

Your risk from these exposures varies, depending on how often you do this type of work. To reduce your exposure to these chemicals: work in a well ventilated area, and work with approved safety equipment, such as those dust masks that are specially designed to filter out microscopic particles.

Table of Contents

INTRODUCTION	2
Foreword	2
Machine Data Sheet.....	2
Contact Info.....	2
Identification	3
SECTION 1: SAFETY	4
Safety Instructions for Machinery.....	4
Safety Instructions for the Tenoning Jig	6
SECTION 2: SET UP	7
Set Up Safety	7
Unpacking	7
Inventory.....	7
Clean Up	8
Table Saw Preparation.....	8
Jig Setup for a Right-Tilt Table Saw	9
Jig Setup for a Left-Tilt Table Saw	10
Guide Bar Adjustment	11
Work Support Plate	11
Adjustment	11
Blade Clearance.....	12
Adjustment	12
Back Stop.....	13
Adjustment	13
SECTION 3: OPERATIONS	14
Operation Safety	14
Overview	14
Basic Tenon Cutting.....	15
SECTION 4: MAINTENANCE	19
Schedule	19
Cleaning	19
Unpainted Cast Iron	19
Lubrication.....	19
Parts List and Breakdown	20
Parts List	21
WARRANTY AND RETURNS	22

INTRODUCTION

Foreword

We are proud to offer the Model H7583 Tenoning Jig. This machine is part of a growing Grizzly family of fine woodworking machinery. When used according to the guidelines set forth in this manual, you can expect years of trouble-free, enjoyable operation and proof of Grizzly's commitment to customer satisfaction.

We are pleased to provide this manual with the Model H7583. It was written to guide you through assembly, review safety considerations, and cover general operating procedures.

The specifications, drawings, and photographs illustrated in this manual represent the Model H7583 as supplied when the manual was prepared. For your convenience, we always keep current Grizzly manuals available on our website at www.grizzly.com. Any updates to your machine will be reflected in these manuals as soon as they are complete.

Contact Info

If you have any comments regarding this manual, please write to us at the address below:

Grizzly Industrial, Inc.
c/o Technical Documentation Manager
P.O. Box 2069
Bellingham, WA 98227-2069

We stand behind our machines. If you have any service questions or parts requests, please call or write us at the location listed below.

Grizzly Industrial, Inc.
1203 Lycoming Mall Circle
Muncy, PA 17756
Phone: (570) 546-9663
Fax: (800) 438-5901
E-Mail: techsupport@grizzly.com
Web Site: <http://www.grizzly.com>

Grizzly
Industrial, Inc.®

MACHINE DATA SHEET

Customer Service #: (570) 546-9663 • To Order Call: (800) 523-4777 • Fax #: (800) 438-5901

MODEL H7583 TENONING JIG

Capacities:

Maximum Clamping Capacity..... 3³/₈"
Back Stop Angles 45° to 90°
Work Support Plate Angles 75° to 90°
Maximum Jig-to-Jig Base Sliding Movement..... 2¹/₄"

Construction:

Jig Material..... Machined/Cast Iron
Jig Weight 20 lbs.

Features:

Major Cutting Width Adjustment..... Sliding Movement
Micro Cutting Width Adjustment..... Threaded Knob Movement
Miter Slot Adjustment..... Setscrew Lash Adjustment



Identification

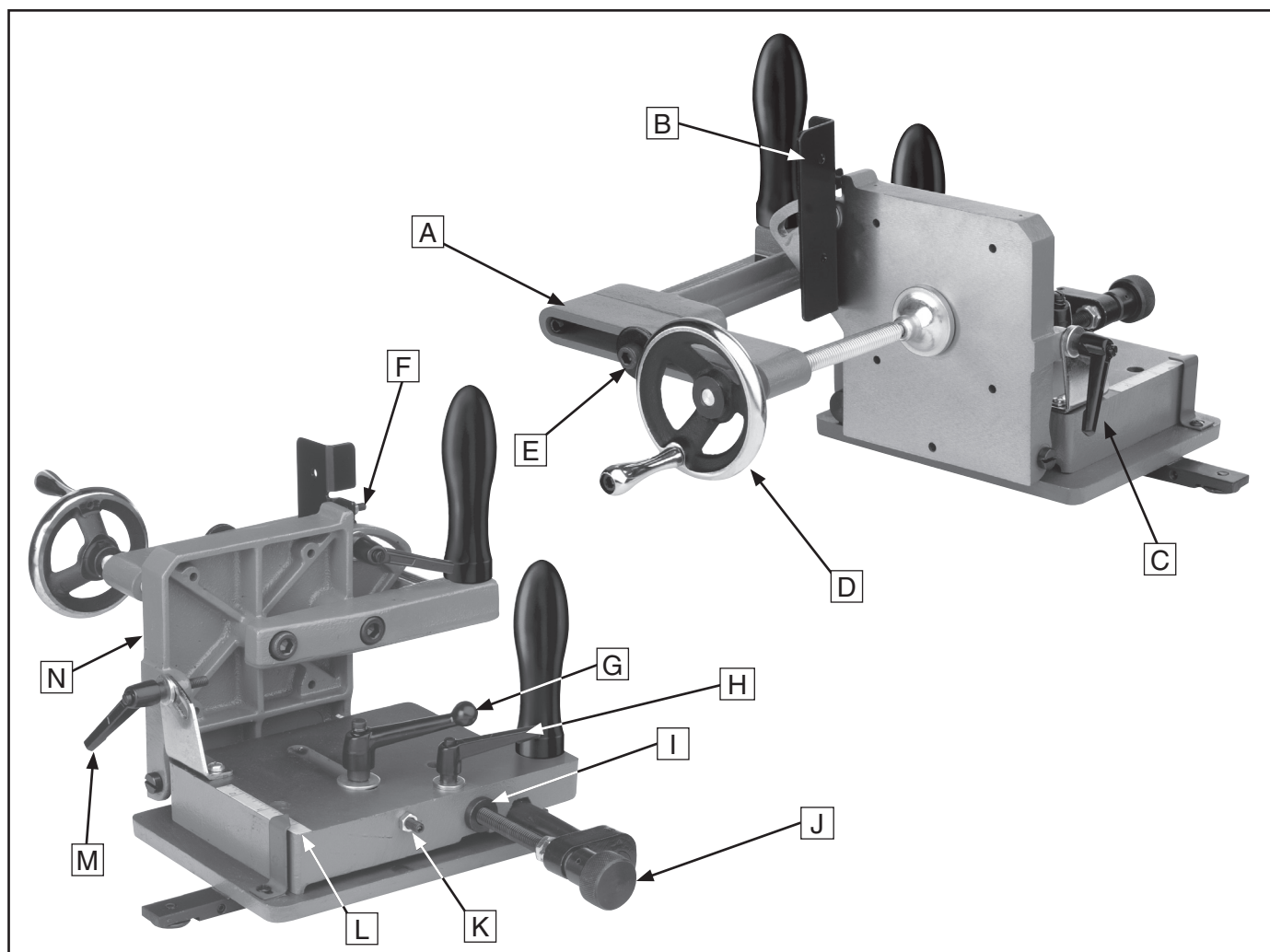

- | | |
|-------------------------------------|--|
| A. Adjustable Clamp Assembly | H. Micro Adjustment Lock Knob |
| B. Back Stop | I. Major Adjustment Sleeve |
| C. Clamp Slide Lock Bolt | J. Depth-of-Cut Micro Adjustment Knob |
| D. Clamp Crank | K. Depth-of-Cut Positive Stop |
| E. Clamp Slide Lock Bolt | L. Depth-of-Cut Scale |
| F. Back Stop Positive Stop | M. Adjustment Lock Lever |
| G. Base Lock Lever | N. Work Support Plate |



SECTION 1: SAFETY

WARNING

For Your Own Safety, Read Instruction Manual Before Operating this Machine

The purpose of safety symbols is to attract your attention to possible hazardous conditions. This manual uses a series of symbols and signal words which are intended to convey the level of importance of the safety messages. The progression of symbols is described below. Remember that safety messages by themselves do not eliminate danger and are not a substitute for proper accident prevention measures.



Indicates an imminently hazardous situation which, if not avoided, **WILL** result in death or serious injury.



Indicates a potentially hazardous situation which, if not avoided, **COULD** result in death or serious injury.



Indicates a potentially hazardous situation which, if not avoided, **MAY** result in minor or moderate injury. It may also be used to alert against unsafe practices.

NOTICE

This symbol is used to alert the user to useful information about proper operation of the machine.

WARNING

Safety Instructions for Machinery

- 1. READ THROUGH THE ENTIRE MANUAL BEFORE STARTING MACHINERY.** Machinery presents serious injury hazards to untrained users.
- 2. ALWAYS USE ANSI APPROVED SAFETY GLASSES WHEN OPERATING MACHINERY.** Everyday eyeglasses only have impact resistant lenses, they are NOT safety glasses.
- 3. ALWAYS WEAR AN ANSI APPROVED RESPIRATOR WHEN OPERATING MACHINERY THAT PRODUCES DUST.** Wood dust is a carcinogen and can cause cancer and severe respiratory illnesses.
- 4. ALWAYS USE HEARING PROTECTION WHEN OPERATING MACHINERY.** Machinery noise can cause permanent hearing damage.
- 5. WEAR PROPER APPAREL. DO NOT** wear loose clothing, gloves, neckties, rings, or jewelry which may get caught in moving parts. Wear protective hair covering to contain long hair and wear non-slip footwear.
- 6. NEVER OPERATE MACHINERY WHEN TIRED, OR UNDER THE INFLUENCE OF DRUGS OR ALCOHOL.** Be mentally alert at all times when running machinery.



WARNING

Safety Instructions for Machinery

7. **ONLY ALLOW TRAINED AND PROPERLY SUPERVISED PERSONNEL TO OPERATE MACHINERY.** Make sure operation instructions are safe and clearly understood.
8. **KEEP CHILDREN AND VISITORS AWAY.** Keep all children and visitors a safe distance from the work area.
9. **MAKE WORKSHOP CHILD PROOF.** Use padlocks, master switches, and remove start switch keys.
10. **NEVER LEAVE WHEN MACHINE IS RUNNING.** Turn power **OFF** and allow all moving parts to come to a complete stop before leaving machine unattended.
11. **DO NOT USE IN DANGEROUS ENVIRONMENTS.** DO NOT use machinery in damp, wet locations, or where any flammable or noxious fumes may exist.
12. **KEEP WORK AREA CLEAN AND WELL LIT.** Clutter and dark shadows may cause accidents.
13. **USE A GROUNDED EXTENSION CORD RATED FOR THE MACHINE AMPERAGE.** Undersized cords overheat and lose power. Replace extension cords if they become damaged. DO NOT use extension cords for 220V machinery.
14. **ALWAYS DISCONNECT FROM POWER SOURCE BEFORE SERVICING MACHINERY.** Make sure switch is in OFF position before reconnecting.
15. **MAINTAIN MACHINERY WITH CARE.** Keep blades sharp and clean for best and safest performance. Follow instructions for lubricating and changing accessories.
16. **MAKE SURE GUARDS ARE IN PLACE AND WORK CORRECTLY BEFORE USING MACHINERY.**
17. **REMOVE ADJUSTING KEYS AND WRENCHES.** Make a habit of checking for keys and adjusting wrenches before turning machinery **ON**.
18. **CHECK FOR DAMAGED PARTS BEFORE USING MACHINERY.** Check for binding and alignment of parts, broken parts, part mounting, loose bolts, and any other conditions that may affect machine operation. Repair or replace damaged parts.
19. **USE RECOMMENDED ACCESSORIES.** Refer to the instruction manual for recommended accessories. The use of improper accessories may cause risk of injury.
20. **DO NOT FORCE MACHINERY.** Work at the speed for which the machine or accessory was designed.
21. **SECURE WORKPIECE.** Use clamps or a vise to hold the workpiece when practical. A secured workpiece protects your hands and frees both hands to operate the machine.
22. **DO NOT OVERREACH.** Keep proper footing and balance at all times.
23. **MANY MACHINES WILL EJECT THE WORKPIECE TOWARD THE OPERATOR.** Know and avoid conditions that cause the workpiece to "kickback."
24. **ALWAYS LOCK MOBILE BASES (IF USED) BEFORE OPERATING MACHINERY.**
25. **BE AWARE THAT CERTAIN WOODS MAY CAUSE AN ALLERGIC REACTION** in people and animals, especially when exposed to fine dust. Make sure you know what type of wood dust you will be exposed to and always wear an approved respirator.



WARNING

Safety Instructions for the Tenoning Jig

- 1. OPERATION MANUAL.** READ and UNDERSTAND the operation manual for the table saw before using this jig!
- 2. KICKBACK.** Be familiar with kickback. Kickback happens when the workpiece is thrown towards the operator at a high rate of speed. *Until you have a clear understanding of kickback and how it occurs, DO NOT operate the table saw!*
- 3. REACHING OVER SAW BLADE.** Never reach behind or over the blade with either hand while the saw is running. *If kickback occurs while reaching over the blade, hands or arms could be pulled into the spinning saw blade.*
- 4. OPERATOR POSITION.** Never stand or have any part of your body directly in-line with the cutting path of the saw blade. Avoid awkward operations and hand positions where a sudden slip could cause your hand to move into the spinning saw blade.
- 5. SECURING WORKPIECE.** ALWAYS securely clamp the workpiece in the tenoning jig, and MAKE SURE all fasteners are tight before you make a cut.
- 6. JIG CONTROL.** Hold both tenoning jig handles firmly when cutting, NEVER hold the jig with only one hand.
- 7. ADJUSTING JIG.** Unplug the table saw before installing or adjusting the jig, saw, or workpiece.
- 8. TENON MATERIAL SELECTION.** Select clean tenon locations that are low in moisture content, and use workpieces that are free of knots, staples, nails, and imbedded stones. Run warped stock through a jointer before you use the tenoning jig.
- 9. WORK AREA CLEANLINESS.** Keep the jig and table surface free of wood bits and tools.
- 10. ACCESSORIES.** Make sure other accessories used on the table saw allow the tenoning jig to operate freely with unbinding travel.
- 11. BLADE GUARD.** Reinstall the blade guard and any other safety features on the table saw when the tenoning jig is removed and not used anymore.
- 12. EXPERIENCING DIFFICULTIES.** If at any time you are experiencing difficulties performing the intended operation, stop using the machine! Contact Tech Support at (570) 546-9663.

WARNING

Like all machines there is danger associated with the Model H7583. Accidents are frequently caused by lack of familiarity or failure to pay attention. Use this machine with respect and caution to lessen the possibility of operator injury. If normal safety precautions are overlooked or ignored, serious personal injury may occur.

CAUTION

No list of safety guidelines can be complete. Every shop environment is different. Always consider safety first, as it applies to your individual working conditions. Use this and other machinery with caution and respect. Failure to do so could result in serious personal injury, damage to equipment, or poor work results.



SECTION 2: SET UP

Set Up Safety

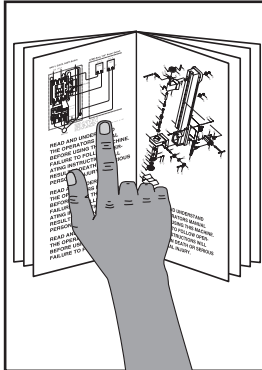

! WARNING
 This jig presents serious injury hazards to untrained users. Read through this entire manual to become familiar with the controls and operations before using this jig!



! WARNING
 Wear safety glasses during the entire set up process!

Unpacking

The Model H7583 was carefully packed when it left our warehouse. If you discover the machine is damaged after you have signed for delivery, please immediately call Customer Service at (570) 546-9663 for advice.

Save the containers and all packing materials for possible inspection by the carrier or its agent. Otherwise, filing a freight claim can be difficult.

When you are completely satisfied with the condition of your shipment, you should inventory the contents.

Inventory

After all the parts have been removed from the two boxes, you should have the following items:

Box 1: (Figure 1)	Qty
A. Work Plate Assembly and Base.....	1
B. Clamp Assembly	1
C. Clamp Handle.....	1
D. Clamp Arm	1
E. Push Handles w/Flat Washer.....	2

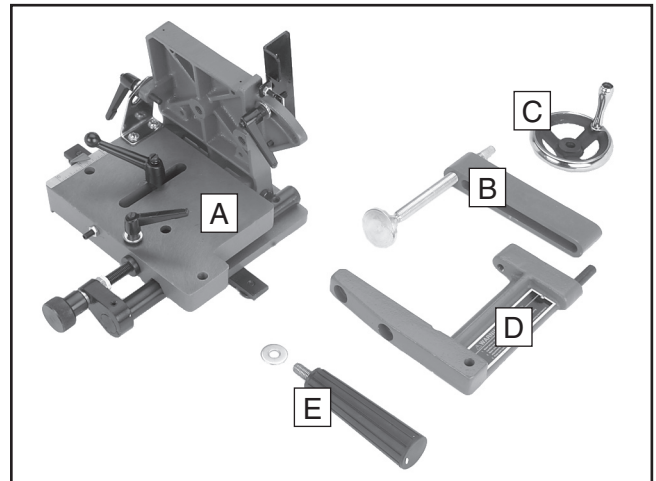



Figure 1. Tenoning jig inventory.

Hardware and Tools	Qty
• Lock Washer 10mm	2
• Fender Washer 8mm	1
• Cap Screw M8-1.25 x 50mm	1
• Cap Screw M10-1.5 x 25mm	1
• Cap Screw M10-1.5 x 20mm	1
• Hex Wrenches 2.5, 3, 4, 6, 8mm	1 Ea

Clean Up

The unpainted surfaces are coated with a waxy oil to protect them from corrosion during shipment. Remove this protective coating with a solvent cleaner or citrus-based degreaser such as Grizzly's G7895 Degreaser. To clean thoroughly, some parts may need to be removed. **For optimum performance from your machine, make sure you clean all moving parts or sliding contact surfaces that are coated.** Avoid chlorine-based solvents, such as acetone or brake parts cleaner, as they may damage painted surfaces should they come in contact. Always follow the manufacturer's instructions when using any type of cleaning product.



!WARNING
Gasoline and petroleum products have low flash points and could cause an explosion or fire if used to clean machinery. **DO NOT** use gasoline or petroleum products to clean the machinery.

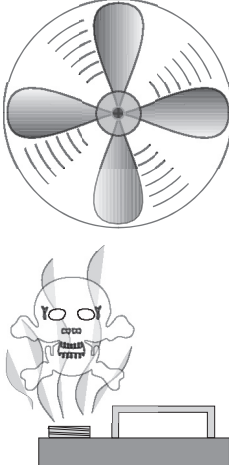

!CAUTION
Many of the solvents commonly used to clean machinery can be toxic when inhaled or ingested. Lack of ventilation while using these solvents could cause serious personal health risks or fire. Take precautions from this hazard by only using cleaning solvents in a well ventilated area.

Table Saw Preparation

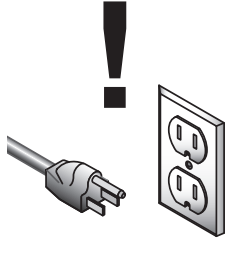

!WARNING
Always disconnect power to the machine before performing adjustments or maintenance. Failure to do this may result in serious personal injury.

The Model H7583 Tenoning Jig is made to operate in a $\frac{3}{8}$ " x $\frac{3}{4}$ " miter T-slot. If the tenoning jig operates on a worn or mis-adjusted saw, tenoning results will be poor. Review the following list to make sure you prepare your saw correctly.

- **Table Saw Operation:** Make sure that you read and understand your table saw instruction manual, and take all safety precautions.
- **Saw Blades:** Make sure that your saw blades have no runout and that the teeth are sharp.
- **Saw Adjustments:** Make sure that your table saw blade is perpendicular to the table and parallel with the miter slots.
- **Miter Slot and Table:** Make sure the table-saw miter slots are $\frac{3}{8}$ " x $\frac{3}{4}$ ", and the table is free of burrs and interferences that may bind the tenoning jig.
- **Lighting:** Make sure the top of your table saw has adequate lighting, so the tenoning jig and workpiece is illuminated without shadows.

!WARNING
DO NOT remove the washer from the miter bar of the tenoning jig. Removal of the washer will allow the tenoning jig to come loose during a kickback, possibly causing a serious personal injury.



Jig Setup for a Right-Tilt Table Saw

In this procedure you will assemble the tenoning jig. The guide bar is initially in position on the jig for jig use on a right-tilting table saw. If you need to use the jig on a left-tilting table saw, go to **Jig Setup for a Left-Tilt Table Saw** on **Page 10**.

To set up the jig for a right tilt table saw:

1. Attach the clamp arm to the work support plate with the cap screws and lock washers as shown in **Figure 2**.

Note: The cap screws are different lengths and must go into the correct holes. See **Figure 2** for the long (M10-1.5 x 25mm), and short cap screw (M10-1.5 x 20mm) hole locations.

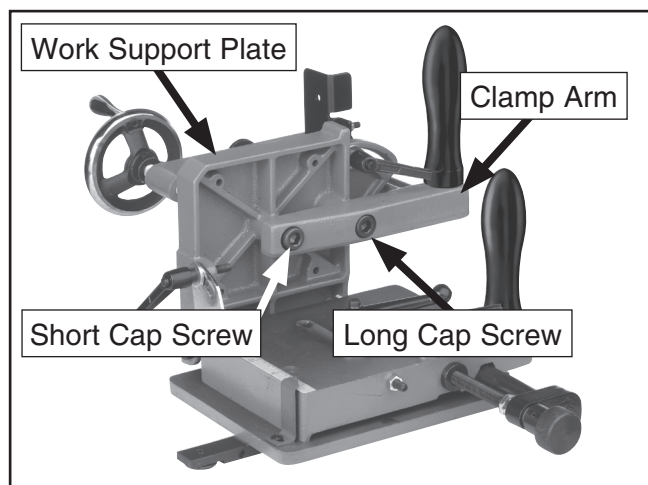

Figure 2. Partial assembly.

2. Install both handles into the jig as shown in **Figure 2**.
3. Slide the handwheel onto the end of the clamp assembly threaded shaft and secure it with the setscrew in the handwheel hub.

4. Attach the clamp assembly to the clamp arm with an M8-1.25 x 50 cap screw and the 8mm fender washer (see **Figure 3**).

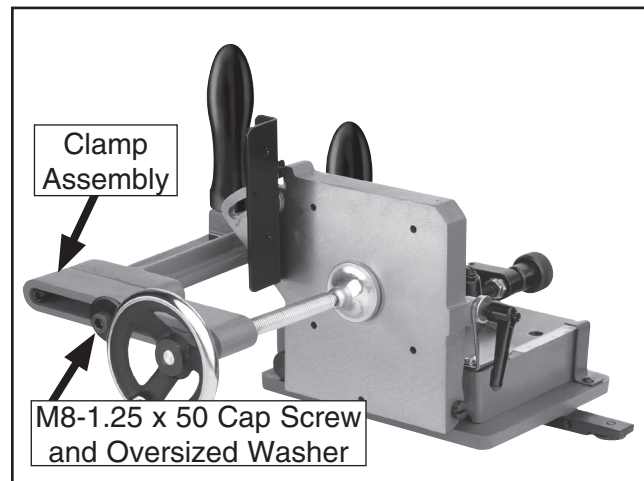

Figure 3. Completed assembly.

5. Insert the jig guide bar into the miter slot in the table-saw table (**Figure 4**), and perform **Guide Bar Adjustment** on **Page 11**.

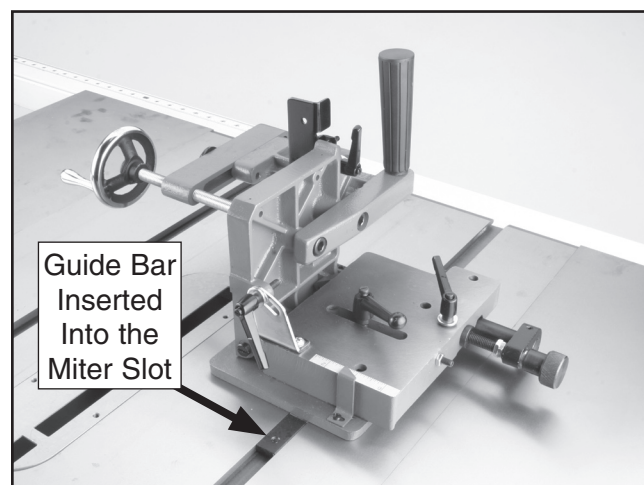

Figure 4. Installed jig.

Jig Setup for a Left-Tilt Table Saw

In this procedure you will partially disassemble the tenoning jig and reassemble it for use on a left-tilting table saw.

To set up the jig for a left tilt table saw:

1. Insert the jig guide bar into the miter slot in the table-saw table.
2. Loosen the small lock lever and remove the large lock lever (see **Figure 5**).

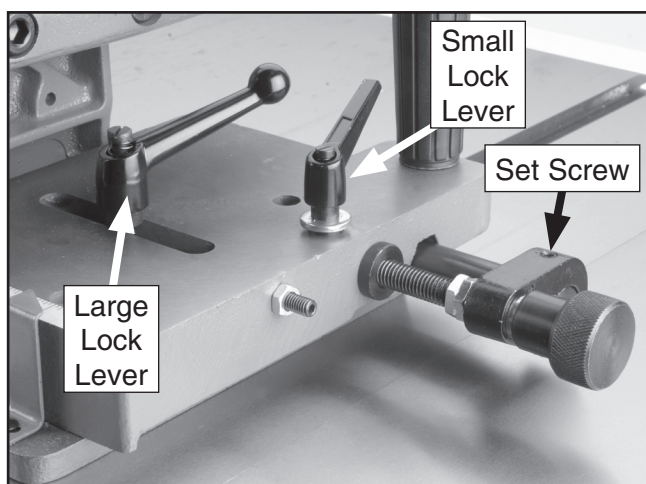

Figure 5. Assembled jig.

3. Loosen the pointer screw, and turn the pointer 90° so the jig assembly and base can be separated (see **Figure 6**).

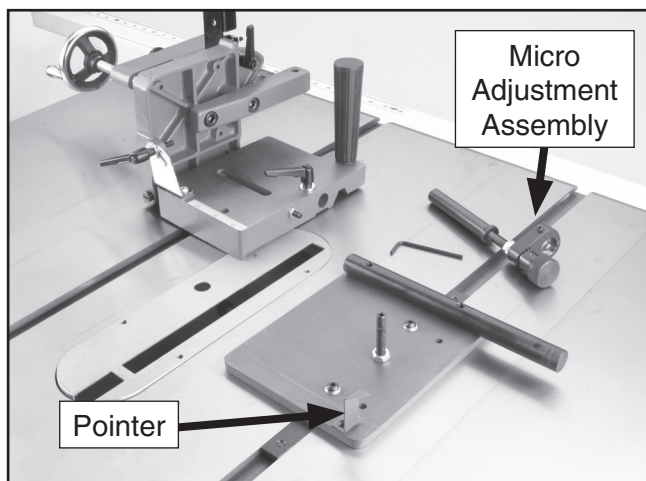

Figure 6. Jig base on a right-tilt table saw.

4. Use the 3mm hex wrench to loosen the set-screw shown in **Figure 5**.
5. Slide the micro adjustment assembly out of the jig, and lift the jig assembly from the base as shown in **Figure 6**.
6. Use the 4mm hex wrench to loosen and remove the two button head screws (**Figure 7**) that hold the guide bar to the base.

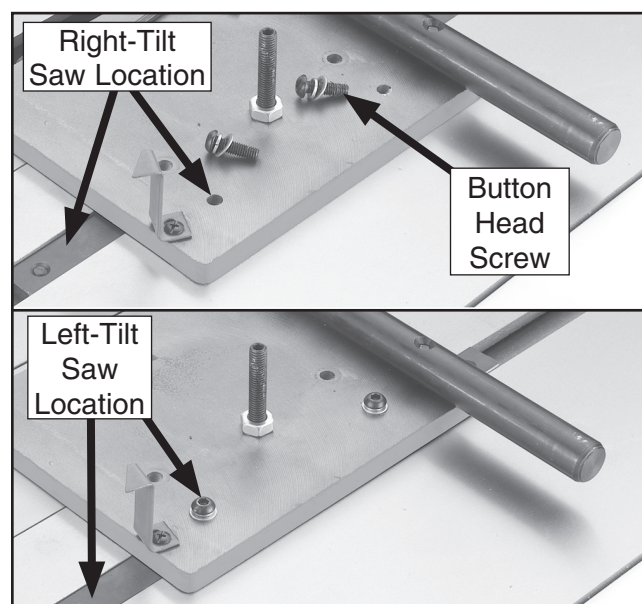

Figure 7. Guide bar locations.

7. Reposition the guide bar to the other set of holes and reinstall the button head screws (see **Figure 7**).
8. Reassemble the jig in reverse order.
9. Go to **Page 11**, and perform the **Guide Bar Adjustment**.

Guide Bar Adjustment

In this procedure you will adjust the guide bar so there is minimal play between the miter slot and guide bar. The jig must slide in the miter slot without side-to-side play or tilt.

To adjust the guide bar:

1. **Unplug the table saw!**
2. Set the guide bar in the left hand miter slot and slide it back and forth to see if there is any play.
 - If the guide bar fits snug, but slides freely in the miter slot, no adjustment is required. Perform the **Work Support Plate Adjustment** on this page.
 - If play exists, continue with the following steps.
3. Remove the jig and set it on a table upside down as shown in **Figure 8**.

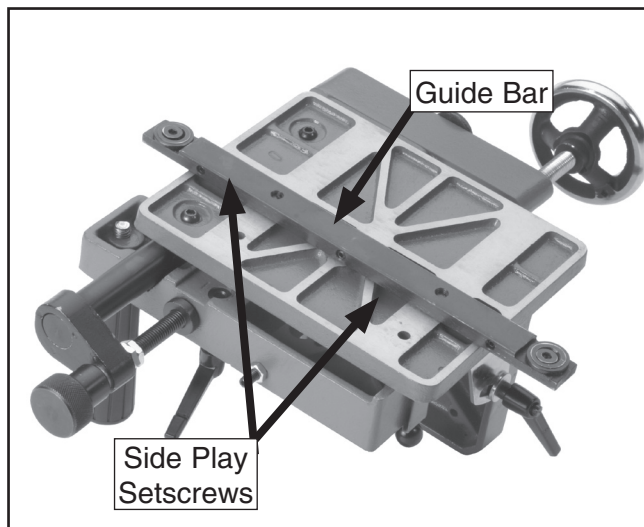

Figure 8. Miter slot guide bar.

4. Use a 2.5mm hex wrench and adjust the side play setscrews shown in **Figure 8** to remove or gain side-to-side play.
5. Reinsert the jig into the miter slot and repeat **Step 2**.

Work Support Plate Adjustment

In this procedure you will adjust the work support plate so it is perpendicular to the table. Then you will set the positive stop so the plate can be quickly returned to the perpendicular position after angle cutting.

To adjust the work support plate:

1. **Unplug the table saw!**
2. Insert the jig and guide bar into the left-hand miter slot and slide the jig into position close to the saw blade.
3. Position a machinist's square against the table and the work support plate as shown in **Figure 9**.

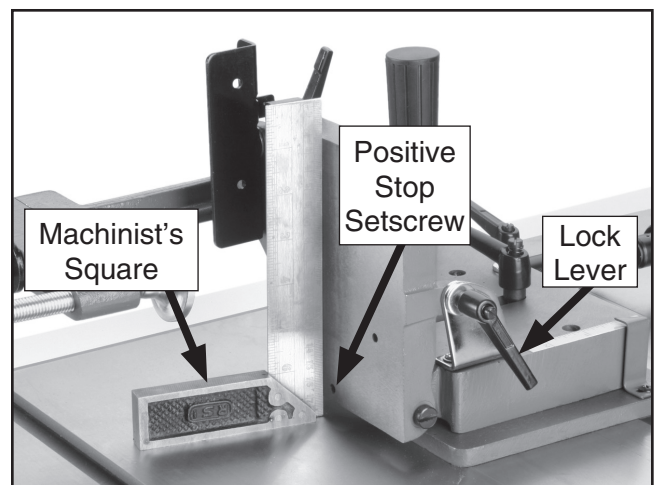

Figure 9. Machinist's square placement.

4. Loosen the lock lever and position the work support plate perpendicular to the table. Tighten the lock lever when perpendicular.
5. Turn the positive stop setscrew (**Figure 9**) inward with a 3mm hex wrench until it stops. The positive stop is now set for quick perpendicular positioning of the work support table.

Blade Clearance Adjustment

In this procedure you will adjust the work support plate parallel and $\frac{1}{8}$ " away from the edge of the saw blade. Then set the positive stop so the work support plate can be quickly returned to this position after cutting various thicknesses.

!WARNING

MAKE SURE the blade clearance is adjusted correctly! **DO NOT** adjust the work support plate any closer than $\frac{1}{8}$ " from the saw blade. If the blade contacts the work support plate, severe injury may occur. If the blade must be closer than $\frac{1}{8}$ " for special circumstances, fasten a block of wood through the holes in the work support plate to prevent the saw blade from contacting the jig.

To adjust the blade clearance:

1. Unplug the table saw!
2. Make sure the saw blade is perpendicular to the table and parallel with the miter slots.
3. Loosen the jam nut and the positive stop approximately 3-4 turns (see **Figure 10**).
4. Loosen the large and small lock levers shown in **Figure 10**.

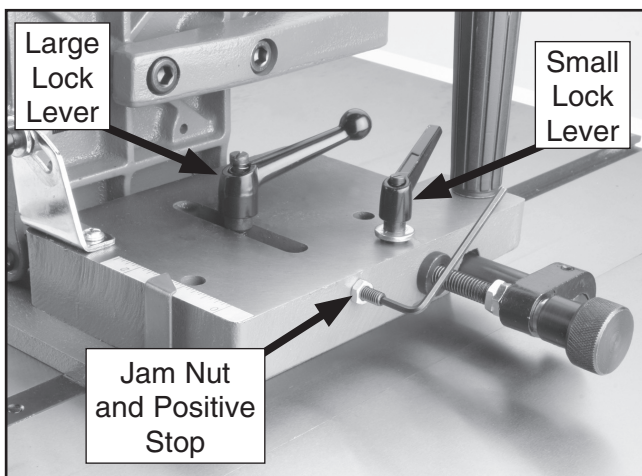

Figure 10. Blade clearance adjustment.

5. Slide the work support plate against the saw blade and tighten the large lock lever.
6. Observe the contact of the saw blade and the work support plate as shown in **Figure 11**.

—If the work support plate is parallel with the blade, go to **Step 10**.

—If the work support plate is not parallel with the blade, go to **Step 7**.

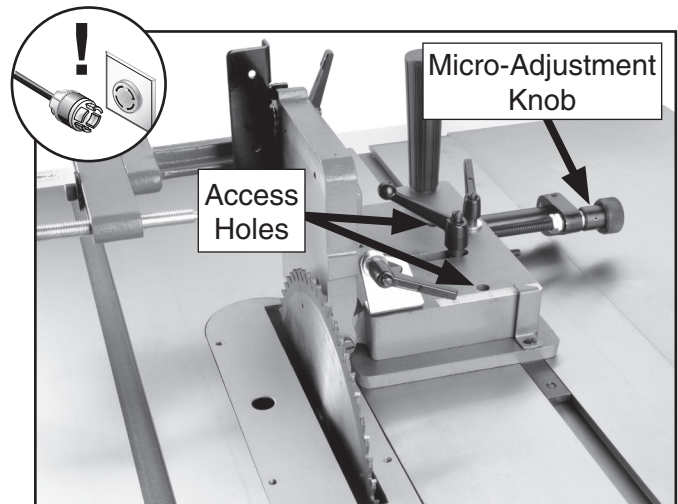

Figure 11. Blade parallelism.

7. Loosen the large lock lever and turn the micro-adjustment knob to align the access holes (**Figure 11**) with the guide bar screws.
8. Insert a 4mm hex wrench through the access holes and loosen the two guide bar screws.
9. Position the work support plate so it is parallel to the saw blade and retighten the two guide bar screws.
10. Move the work support plate $\frac{1}{8}$ " away from the edge of the saw blade and tighten the large lock lever.

10. Rotate the micro-adjustment knob until the major adjustment sleeve extends $1\frac{1}{2}$ " out of the jig, or approximately halfway between the knob and the side of the jig (see **Figure 12**).

Note: The major adjustment sleeve allows for quick adjustment of the jig positioning. The micro adjustment knob fine tunes the quick adjustment that was made.

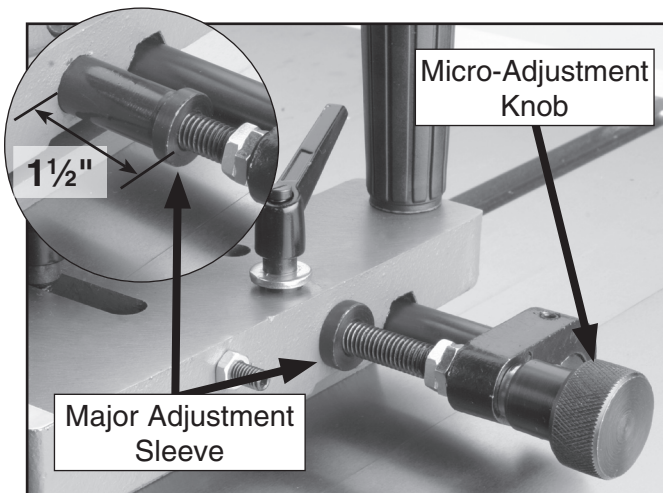

Figure 12. Setting major adjustment sleeve.

11. Tighten the small lock lever and use a 3mm hex wrench to turn the positive stop setscrew inward until it stops (see **Figure 10**).

Note: The positive stop prevents the work support plate from sliding into the saw blade.

12. Tighten the jam nut and make sure the work support plate stops an $\frac{1}{8}$ " away from the edge of the saw blade.
13. Loosen the pointer screw and reposition the pointer to "0" on the scale.

Back Stop Adjustment

In this procedure you will adjust the back stop perpendicular to the table. Then set the positive stop so the back stop can be returned to the perpendicular position after angle cutting.

To adjust the back stop, do these steps:

1. **Unplug the table saw!**
2. Place the jig into the miter slot. Position a machinist's square against the back stop as shown in **Figure 13**.

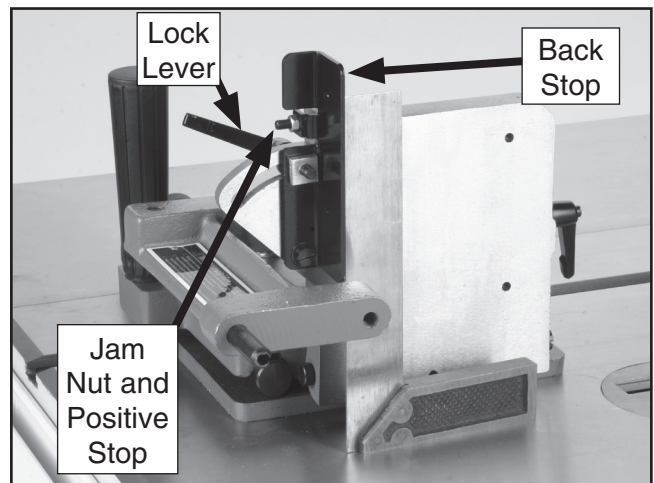

Figure 13. Machinist's square location.

3. Loosen the lock lever. Position the back stop perpendicular to the table, and tighten the lock lever.
4. Loosen the positive stop jam nut with an 8mm wrench. Use a 2.5mm hex wrench to turn the setscrew inward until it stops, and tighten the jam nut.

SECTION 3: OPERATIONS

Operation Safety

⚠️ WARNING

Damage to your eyes, lungs, and ears could result from using this jig without proper protective gear. Always wear safety glasses, a respirator, and hearing protection when operating machinery.

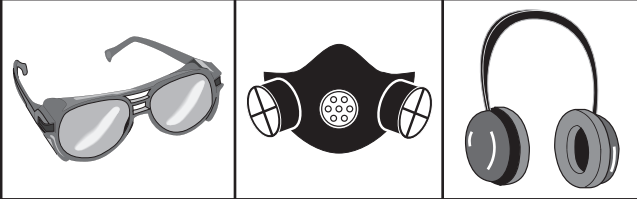

⚠️ WARNING

Loose hair and clothing could get caught in machinery and cause serious personal injury. Keep loose clothing and long hair away from moving machinery.

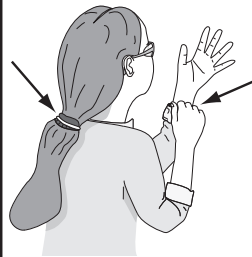

NOTICE

If you have never used this type of jig before, WE STRONGLY RECOMMEND that you read books, trade magazines, or get formal training before beginning any projects. Regardless of the content in this section, Grizzly Industrial will not be held liable for accidents caused by lack of training.

Overview

Your new tenoning jig features three positive stops that allow for fast and accurate positioning of the back stop angle, work support angle, and work support distance from the blade. This jig is designed to make tenon cheek cuts only; however, you can make many special variations to the basic tenon that is shown in **Figures 14 & 15**.

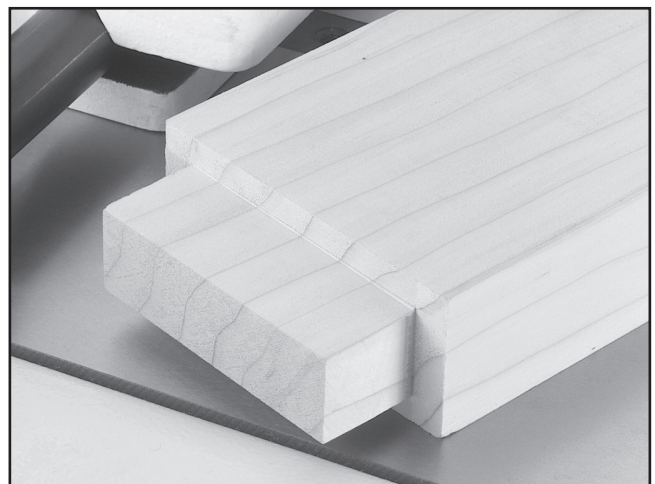

Figure 14. Basic tenon.

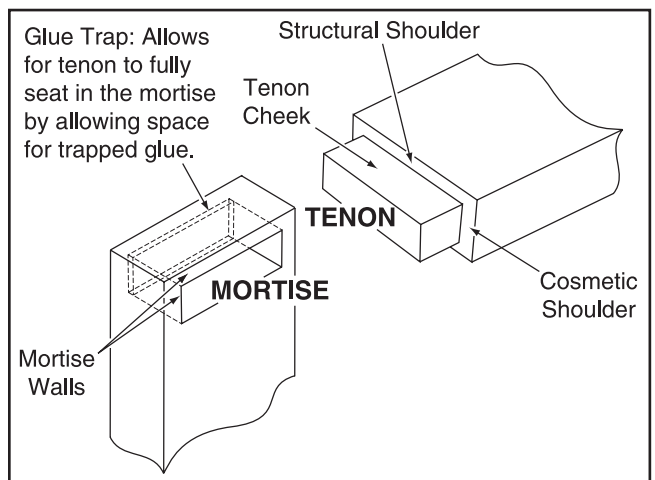

Figure 15. Typical mortise and tenon.



Basic Tenon Cutting

Your new tenoning jig is designed to make tenon cheek cuts only, and generally, cheek cuts are made before the shoulder cuts. This procedure will guide you through three parts; A, B, and C to show you how to cut your first basic tenon.

A. Preparing the tenoning jig and workpiece:

Note: *The shoulder cuts and angle cuts are made on the table saw with the miter gauge.*

1. Select your mortise and tenon joints, and draw the cutting lines as shown in **Figure 16**. Make sure to account for the thickness of the saw blade.

—For the strongest joints, select joint locations that are free of knots and twists.

—Tenons need structural and cosmetic shoulders to hide gaps that may occur as the wood shrinks.

—When joining parts of the same thickness, make the tenon the same thickness as the tenon walls.

—When joining parts where one piece is larger than the other, make the tenon as thick as possible.

—Make the mortise $\frac{1}{8}$ " deeper than the tenon to allow for the glue to squeeze out.

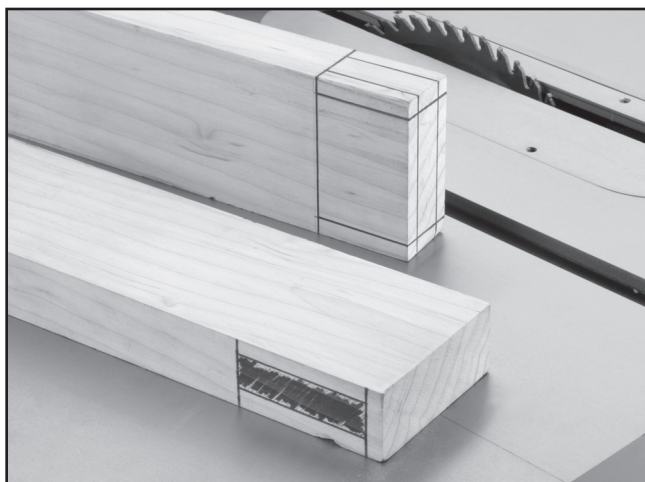
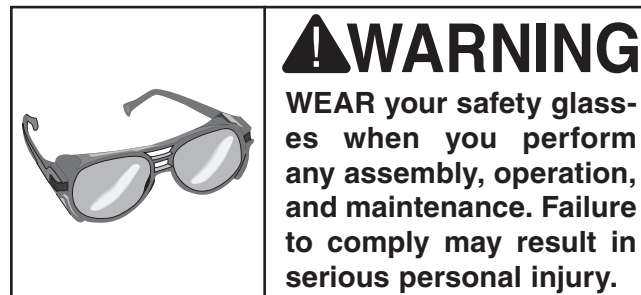

Figure 16. Tenon layout.



2. Plane a wood base stop to the thickness of the tenoning jig base, and mount it to the front of the table saw as shown in **Figure 17**. The base stop prevents cut off pieces getting trapped between the saw blade and the work support plate.

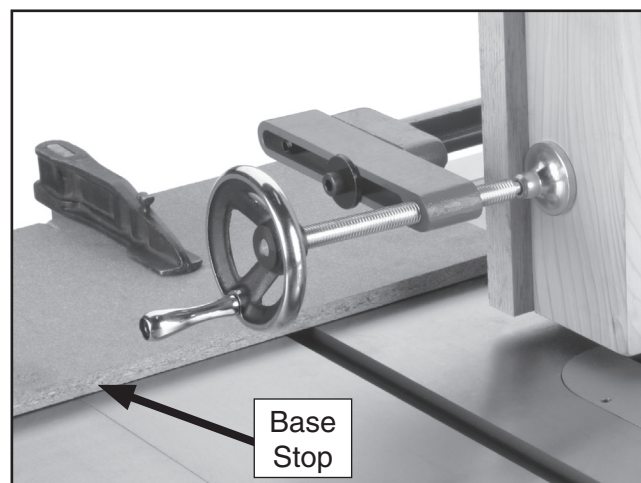

Figure 17. Base stop attached to the table saw.

3. Cut a wooden spacer block the same thickness as the tenon plus the saw blade. Screw through the holes in the work support plate to attach the spacer block (see **Figure 18**).

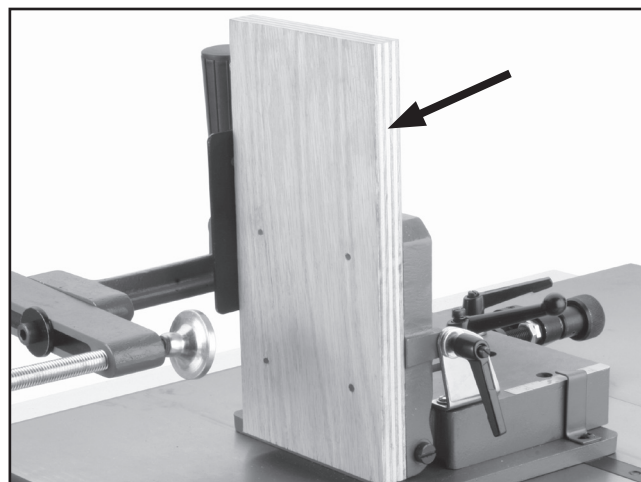

Figure 18. Work support spacer block.

4. Cut a back stop backup board and screw it to the back stop as shown in **Figure 19**.

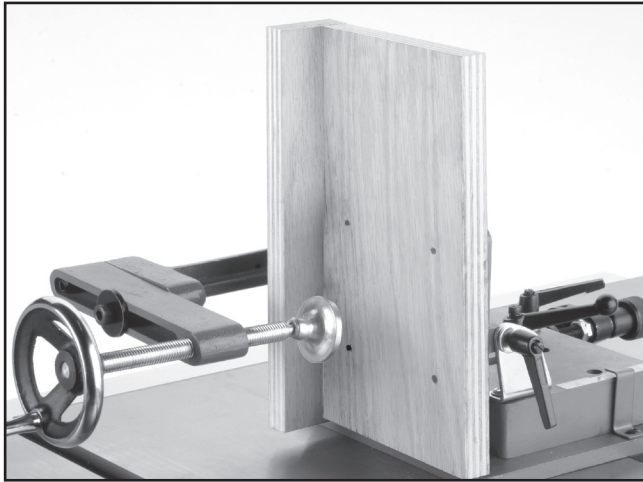

Figure 19. Back stop backup board.

5. Slide the jig back to the base stop, place the workpiece on the base stop, and clamp the workpiece against spacer block and back stop as shown in **Figure 20**.

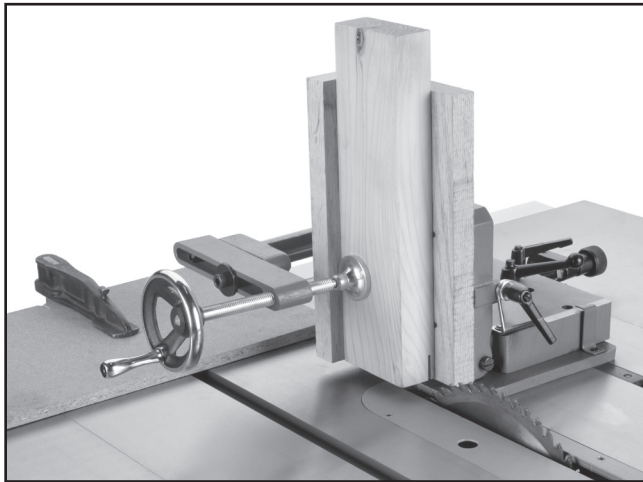

Figure 20. Clamping the workpiece.

!WARNING

MAKE SURE the blade clearance is adjusted correctly! **DO NOT** adjust the work support plate any closer than $\frac{1}{8}$ " from the saw blade. If the blade contacts the work support plate, severe injury may occur. If the blade must be closer than $\frac{1}{8}$ " for special circumstances, fasten a block of wood through the holes in the work support plate to prevent the saw blade from contacting the jig.

6. Slide the jig up next to the saw blade, and use the major and micro adjustments (**Figure 21**) to line up the layout lines on the workpiece with the saw blade.

Note: *The major adjustment sleeve allows for quick adjustment of the jig positioning, and the micro adjustment knob fine tunes the quick adjustment that was made.*

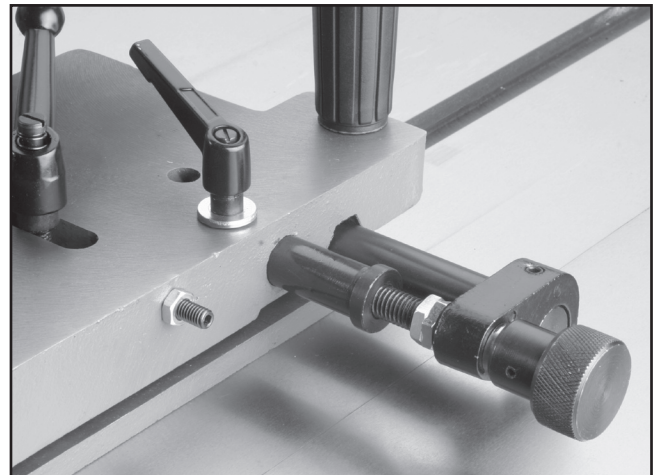

Figure 21. Major adjustment sleeve and micro adjustment knob.

B. Cutting Tenon Cheeks:

The tenon uses two styles of cheeks, structural and cosmetic. In this procedure you will cut the structural cheeks first, then the cosmetic cheeks.

1. Make sure all jig fixtures, lock levers, and setscrews are tight and correctly adjusted.
2. Plug the table saw power cord into the power supply and turn the saw **ON**.
3. Grasp the jig firmly and slowly slide the jig toward the saw blade and make the first structural-cheek cut (see **Figure 22**). DO NOT slide the jig quickly toward the saw blade or the jig can raise up and away from the table.

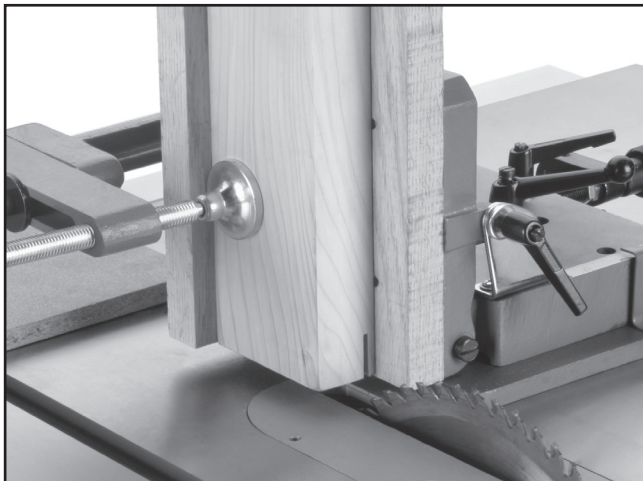

Figure 22. First structural cheek cut.

4. When the blade exits the workpiece, carefully and slowly pull the jig back past the blade to the base stop and turn **OFF** the saw.

5. Remove the spacer block from the work support base and re-clip the workpiece.
6. Turn the saw **ON** and make the second cut as shown in **Figure 23** and turn **OFF** the saw.

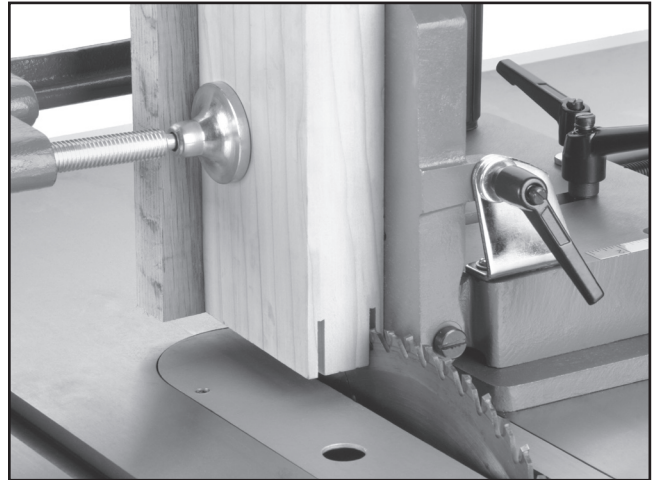

Figure 23. Second structural cheek cut.

7. Rotate the workpiece so you can now cut the two cosmetic cheeks.
8. Power up the saw, and make the remaining cosmetic cheek cuts the same way as in **Steps 3 & 4**, unplug and turn **OFF** the saw (see **Figure 24**).

Note: For cosmetic cheek cuts, merely rotate the workpiece 180° instead of using the spacer block. Cosmetic cheek cut positioning is not as critical for structural cheek cuts.

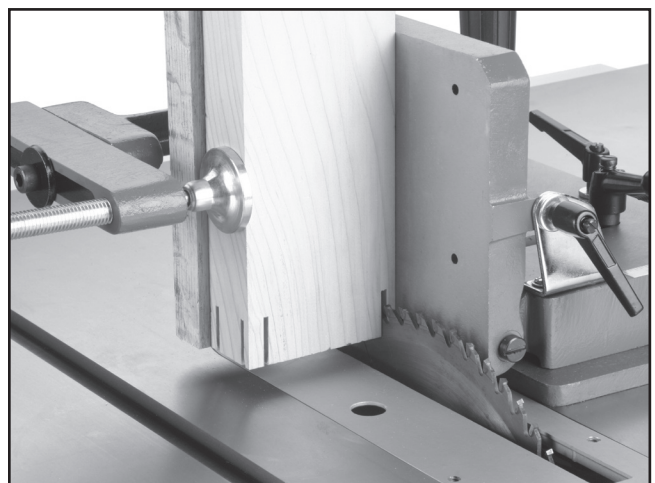

Figure 24. Third and fourth cosmetic cheek cuts.

C. Cutting Tenon Shoulders:

The final set of cuts are two structural shoulder cuts and two cosmetic shoulder cuts. In this procedure you will complete the tenon by using the table saw fence, a stop block clamped to the fence, the saw miter gauge, and the base stop.

!WARNING

ALWAYS use a cross-cut saw blade when making tenon shoulder cuts. Otherwise, the saw can grab the workpiece causing machine damage and severe personal injury!

1. Remove the jig from the table saw install a cross-cut saw blade and the miter gauge.
2. Adjust the saw blade height to cut the tenon structural shoulder as shown in **Figure 25**.

Note: When cutting tenon shoulders, avoid nicking the cheeks of the tenon. Nicks in the tenons greatly weaken them.

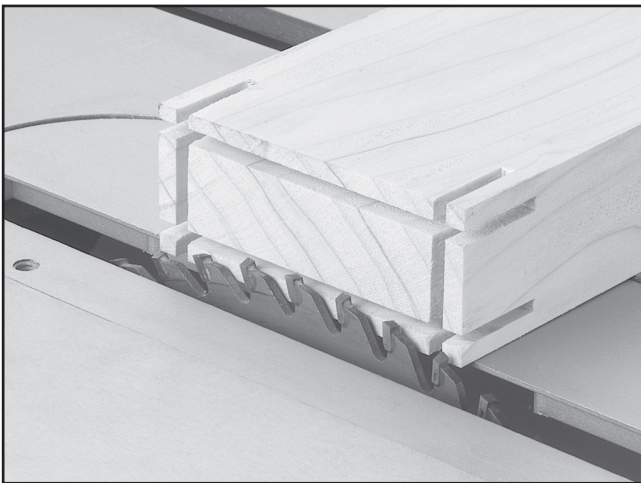

Figure 25. Adjusting the saw blade height.

!WARNING

ALWAYS clamp the fence stop block in front of the saw blade so the workpiece will not be trapped between the saw blade and the fence. When the work piece begins to be cut, the workpiece must be free from the stop block. Ignoring this warning may cause kickback and severe personal injury!

3. Clamp a stop block to the fence face before the saw blade (**Figure 26**) and adjust the fence to cut the structural shoulder. Remember, take into account the thickness of the blade.



Figure 26. Cutting the shoulder.

4. Position the workpiece against the miter gauge (equipped with a backing board) and the fence stop block.
5. Turn the saw **ON**, and carefully and slowly push the miter gauge to cut the structural shoulder as shown in **Figure 26**.
6. Turn the saw **OFF**, and when the blade is stopped, remove the cut-off piece of wood.
7. Repeat **Steps 2-6** to cut the remaining shoulders.

SECTION 4: MAINTENANCE



Schedule

For optimum performance from your jig, follow this maintenance schedule and refer to any specific instructions given in this section.

Daily Check:

- Loose mounting bolts, levers, setscrews and jam nuts.
- Worn or damaged parts.
- Rust or corrosion on threads and machined surfaces.
- Any other unsafe condition.

Cleaning

Cleaning the Model H7583 is relatively easy. Vacuum excess wood chips and sawdust, and wipe off the remaining dust with a dry cloth. If any resin has built up, use a resin dissolving cleaner to remove it. Treat all unpainted cast iron and steel with a non-staining lubricant after cleaning.

Unpainted Cast Iron

Protect the unpainted cast iron surfaces on the jig by wiping it clean after every use—this ensures moisture from wood dust does not remain on bare metal surfaces.

Keep unpainted cast iron rust-free with regular applications of products like G96® Gun Treatment, SLIPIT®, or Boeshield® T-9.

Lubrication

For setscrew and lock lever threads, an occasional application of light machine oil is all that is necessary. Before applying lubricant, clean off sawdust.

Your goal is to achieve adequate lubrication. Too much lubrication will attract dirt and sawdust. Various parts of your jig could lose their freedom of movement as a result.



Parts List and Breakdown

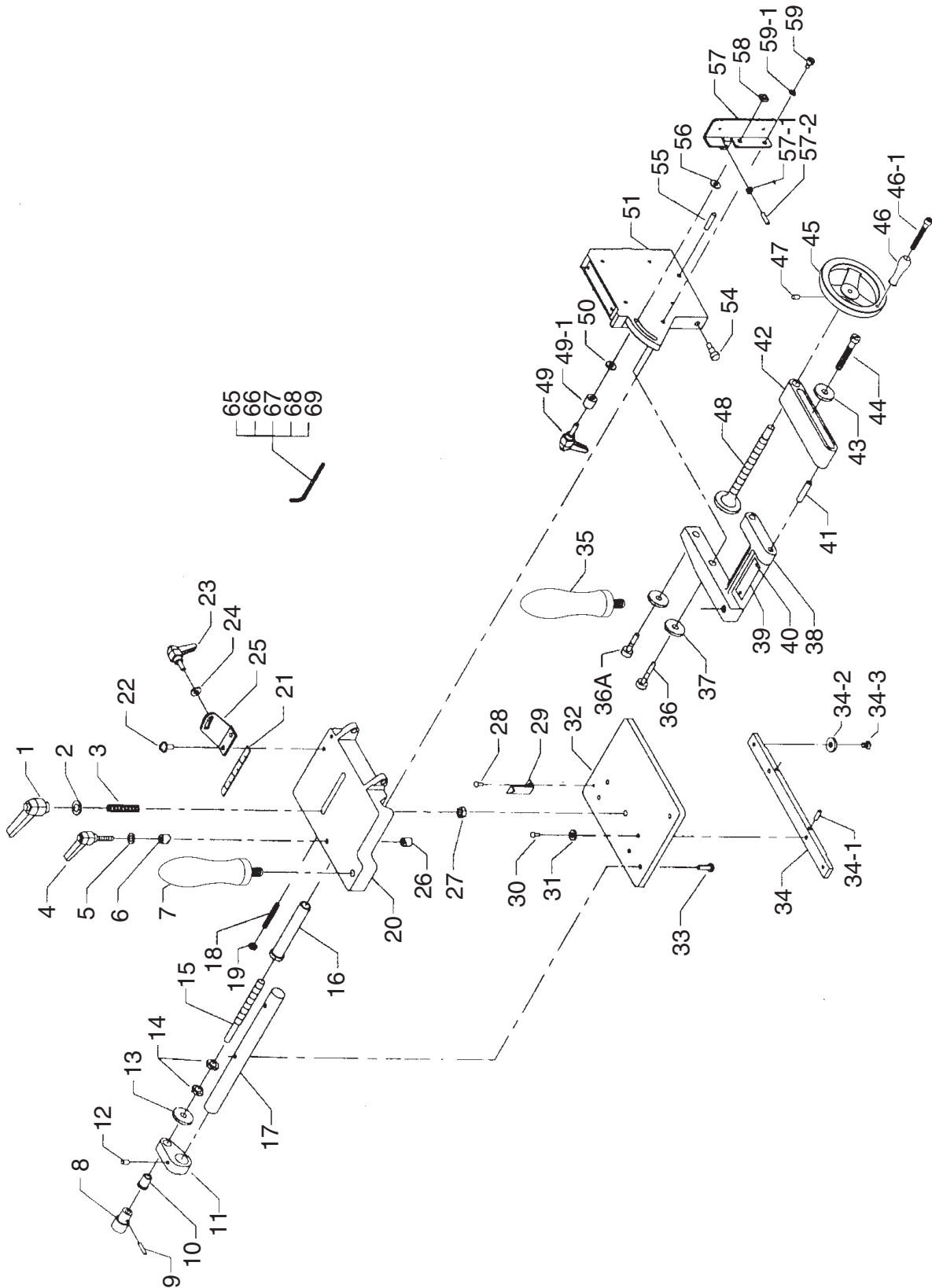

Parts List

REF	PART #	DESCRIPTION
1	PH7583001	LOCK LEVER M8-1.25
2	PW01M	FLAT WASHER 8MM
3	PH7583003	STUD M8-1.25 X 55
4	PH7583004	LOCK LEVER M6-1 X 28
5	PW03M	FLAT WASHER 6MM
6	PH7583006	LOCK BUSHING
7	PH7583007	HANDLE M10-1.5 X 20
8	PH7583008	KNURLED KNOB 10MM PINNED
9	PRP42M	ROLL PIN 3 X 20
10	PH7583010	BUSHING
11	PH7583011	BRACKET
12	PSS01M	SET SCREW M6-1 X 10
13	PH7583013	NYLON WASHER 10MM
14	PN02M	HEX NUT M10-1.5
15	PH7583015	SHAFT
16	PH7583016	GUIDE BUSHING
17	PH7583017	GUIDE ROD
18	PSS85M	SET SCREW M6-1 X 45
19	PN01M	HEX NUT M6-1
20	PH7583020	SLIDE
21	PH7583021	SCALE
22	PS09M	PHLP HD SCR M5-.8 X 10
23	PH7583004	LOCK LEVER M6-1 X 28
24	PW03M	FLAT WASHER 6MM
25	PH7583025	BRACKET
26	PH7583026	BUSHING
27	PN03M	HEX NUT M8-1.25
28	PS07M	PHLP HD SCR M4-.7 X 8
29	PH7583029	POINTER
30	PSBS05M	BUTTON HD CAP SCR M6-1 X 20
31	PLW03M	LOCK WASHER 6MM
32	PH7583032	BASE
33	PSBS05M	BUTTON HD CAP SCR M6-1 X 20
34	PH7583034	GUIDE BAR
34-1	PH7583034-1	PILOT SET SCREW M5-.8 X 16
34-2	PH7583034-2	PLATE

REF	PART #	DESCRIPTION
34-3	PH7583034-3	FLAT HD SCR 1/4-28 X 5/16
35	PH7583007	HANDLE M10-1.5 X 20
36	PSB64M	CAP SCREW M10-1.5 X 25
36A	PSB61M	CAP SCREW M10-1.5 X 20
37	PLW06M	LOCK WASHER 10MM
38	PH7583038	CLAMP BRACKET
39	PH7583039	WARNING LABEL
40	PH7583040	SPECIAL NAIL 4 X 8
41	PH7583041	ROLL PIN 3/8 X 2"
42	PH7583042	CLAMP ARM
43	PW01M	FLAT WASHER 8MM
44	PSB05M	CAP SCREW M8-1.25 X 50
45	PH7583045	HANDWHEEL
46	PH7583046	HANDWHEEL HANDLE
46-1	PH7583046-1	SPECIAL SCREW M6-1 X 55
47	PSS03M	SET SCREW M6-1 X 8
48	PH7583048	CLAMP SCREW
49	PH7583004	LOCK LEVER M6-1 X 28
49-1	PH7583006	LOCK BUSHING
50	PW03M	FLAT WASHER 6MM
51	PH7583051	VERTICAL TABLE
54	PH7583054	SHOULDER SCREW M6 X 20
55	PSS12M	SET SCREW M6-1 X 25
56	PW03M	FLAT WASHER 6MM
57	PH7583057	STOP
57-1	PN06M	HEX NUT M5-.8
57-2	PSS57M	SET SCREW M5-.8 X 20
58	PSN02M	SQUARE NUT M6-1
59	PH7583059	SPECIAL SLOT SCREW M5-.8 X 10
59-1	PH7583059-1	WAVY WASHER 6MM
65	PAW03M	HEX WRENCH 3MM
66	PAW04M	HEX WRENCH 4MM
67	PAW06M	HEX WRENCH 6MM
68	PAW08M	HEX WRENCH 8MM
69	PAW02.5M	HEX WRENCH 2.5MM



WARRANTY AND RETURNS

Grizzly Industrial, Inc. warrants every product it sells for a period of **1 year** to the original purchaser from the date of purchase. This warranty does not apply to defects due directly or indirectly to misuse, abuse, negligence, accidents, repairs or alterations or lack of maintenance. This is Grizzly's sole written warranty and any and all warranties that may be implied by law, including any merchantability or fitness, for any particular purpose, are hereby limited to the duration of this written warranty. We do not warrant or represent that the merchandise complies with the provisions of any law or acts unless the manufacturer so warrants. In no event shall Grizzly's liability under this warranty exceed the purchase price paid for the product and any legal actions brought against Grizzly shall be tried in the State of Washington, County of Whatcom.

We shall in no event be liable for death, injuries to persons or property or for incidental, contingent, special, or consequential damages arising from the use of our products.

To take advantage of this warranty, contact us by mail or phone and give us all the details. We will then issue you a "Return Number," which must be clearly posted on the outside as well as the inside of the carton. We will not accept any item back without this number. Proof of purchase must accompany the merchandise.

The manufacturers reserve the right to change specifications at any time because they constantly strive to achieve better quality equipment. We make every effort to ensure that our products meet high quality and durability standards and we hope you never need to use this warranty.

Please feel free to write or call us if you have any questions about the machine or the manual.

Thank you again for your business and continued support. We hope to serve you again soon.





WARRANTY CARD

Name _____
 Street _____
 City _____ State _____ Zip _____
 Phone # _____ Email _____ Invoice # _____
 Model # _____ Order # _____ Serial # _____

The following information is given on a voluntary basis. It will be used for marketing purposes to help us develop better products and services. **Of course, all information is strictly confidential.**

1. How did you learn about us?

Advertisement Friend Catalog
 Card Deck Website Other:

2. Which of the following magazines do you subscribe to?

<input type="checkbox"/> Cabinet Maker	<input type="checkbox"/> Popular Mechanics	<input type="checkbox"/> Today's Homeowner
<input type="checkbox"/> Family Handyman	<input type="checkbox"/> Popular Science	<input type="checkbox"/> Wood
<input type="checkbox"/> Hand Loader	<input type="checkbox"/> Popular Woodworking	<input type="checkbox"/> Wooden Boat
<input type="checkbox"/> Handy	<input type="checkbox"/> Practical Homeowner	<input type="checkbox"/> Woodshop News
<input type="checkbox"/> Home Shop Machinist	<input type="checkbox"/> Precision Shooter	<input type="checkbox"/> Woodsmith
<input type="checkbox"/> Journal of Light Cont.	<input type="checkbox"/> Projects in Metal	<input type="checkbox"/> Woodwork
<input type="checkbox"/> Live Steam	<input type="checkbox"/> RC Modeler	<input type="checkbox"/> Woodworker West
<input type="checkbox"/> Model Airplane News	<input type="checkbox"/> Rifle	<input type="checkbox"/> Woodworker's Journal
<input type="checkbox"/> Modeltec	<input type="checkbox"/> Shop Notes	<input type="checkbox"/> Other:
<input type="checkbox"/> Old House Journal	<input type="checkbox"/> Shotgun News	

3. What is your annual household income?

\$20,000-\$29,000 \$30,000-\$39,000 \$40,000-\$49,000
 \$50,000-\$59,000 \$60,000-\$69,000 \$70,000+

4. What is your age group?

20-29 30-39 40-49
 50-59 60-69 70+

5. How long have you been a woodworker/metalworker?

0-2 Years 2-8 Years 8-20 Years 20+ Years

6. How many of your machines or tools are Grizzly?

0-2 3-5 6-9 10+

7. Do you think your machine represents a good value?

Yes No

8. Would you recommend Grizzly Industrial to a friend?

Yes No

9. Would you allow us to use your name as a reference for Grizzly customers in your area?

Note: *We never use names more than 3 times.* Yes No

10. Comments: _____

CUT ALONG DOTTED LINE

FOLD ALONG DOTTED LINE



Place
Stamp
Here



GRIZZLY INDUSTRIAL, INC.
P.O. BOX 2069
BELLINGHAM, WA 98227-2069



FOLD ALONG DOTTED LINE

Send a Grizzly Catalog to a friend:

Name _____
Street _____
City _____ State _____ Zip _____

TAPE ALONG EDGES--PLEASE DO NOT STAPLE

grizzly.com

TOOL WEBSITE

Buy Direct and Save with Grizzly® – Trusted, Proven and a Great Value!

*Visit Our Website Today And Discover Why
Grizzly® Is The Industry Leader!*

- SECURE ORDERING
- ORDERS SHIPPED WITHIN 24 HOURS
- E-MAIL RESPONSE WITHIN ONE HOUR

-OR-

Call Today For A **FREE**
Full Color Catalog

1-800-523-4777



Free Manuals Download Website

<http://myh66.com>

<http://usermanuals.us>

<http://www.somanuals.com>

<http://www.4manuals.cc>

<http://www.manual-lib.com>

<http://www.404manual.com>

<http://www.luxmanual.com>

<http://aubethermostatmanual.com>

Golf course search by state

<http://golfingnear.com>

Email search by domain

<http://emailbydomain.com>

Auto manuals search

<http://auto.somanuals.com>

TV manuals search

<http://tv.somanuals.com>