



WWW.GRIZZLY.COM

VARIABLE SPEED JIG SAW

MODEL G8994Z

INSTRUCTION MANUAL



COPYRIGHT ©2000 BY GRIZZLY INDUSTRIAL, INC.  
1821 VALENCIA ST., BELLINGHAM, WA 98227

**WARNING: NO PORTION OF THIS MANUAL MAY BE REPRODUCED IN ANY SHAPE  
OR FORM WITHOUT THE WRITTEN APPROVAL OF GRIZZLY INDUSTRIAL, INC.**

JUNE, 2001 PRINTED IN U.S.A.

# WARNING

Some dust created by power sanding, sawing, grinding, drilling, and other construction activities contains chemicals known to the State of California to cause cancer, birth defects or other reproductive harm. Some examples of these chemicals are:

- Lead from lead-based paints.
- Crystalline silica from bricks, cement, and other masonry products.
- Arsenic and chromium from chemically treated lumber.

Your risk from these exposures varies, depending on how often you do this type of work. To reduce your exposure to these chemicals: work in a well ventilated area, and work with approved safety equipment, such as those dust masks that are specially designed to filter out microscopic particles.

# SAFETY

## **WARNING**

### For Your Own Safety Read Instruction Manual Before Operating This Equipment

The purpose of safety symbols is to attract your attention to possible hazardous conditions. This manual uses a series of symbols and signal words which are intended to convey the level of importance of the safety messages. The progression of symbols is described below. Remember that safety messages by themselves do not eliminate danger and are not a substitute for proper accident prevention measures.

#### **DANGER**

Indicates an imminently hazardous situation which, if not avoided, WILL result in death or serious injury.

#### **WARNING**

Indicates a potentially hazardous situation which, if not avoided, COULD result in death or serious injury.

#### **CAUTION**

Indicates a potentially hazardous situation which, if not avoided, MAY result in minor or moderate injury. It may also be used to alert against unsafe practices.

#### **NOTICE**

This symbol is used to alert the user to useful information about proper operation of the equipment.

## **WARNING**

### Safety Instructions For Power Tools

- KEEP ALL SAFETY DEVICES IN PLACE** and in working order.
- REMOVE ADJUSTING KEYS AND WRENCHES.** Form habit of checking to see that keys and adjusting wrenches are removed from tool before turning on.
- KEEP WORK AREA CLEAN.** Cluttered areas and benches invite accidents.
- DON'T USE IN DANGEROUS ENVIRONMENT.** Don't use power tools in damp or wet locations, or where any flammable or noxious fumes may exist. Keep work area well lighted.
- KEEP CHILDREN AND VISITORS AWAY.** All children and visitors should be kept a safe distance from work area.
- MAKE WORKSHOP CHILD PROOF** with padlocks, master switches, or by removing starter keys.
- DON'T FORCE TOOL.** It will do the job better and safer at the rate for which it was designed.
- USE RIGHT TOOL.** Don't force tool or attachment to do a job for which it was not designed.
- DO NOT USE UNDER THE INFLUENCE OF DRUGS OR ALCOHOL.**

# WARNING

## Safety Instructions For Power Tools

### 10. USE PROPER EXTENSION CORD

for the charger. Make sure your extension cord is in good condition. Conductor size should be in accordance with the chart below. The amperage rating should be listed on the motor or tool nameplate. An undersized cord will cause a drop in line voltage resulting in loss of power and overheating. Your extension cord must also contain a ground wire and plug pin. Always repair or replace extension cords if they become damaged.

Minimum Gauge for Extension Cords

AMP RATING	LENGTH		
	25ft	50ft	100ft
0-6	18	16	16
7-10	18	16	14
11-12	16	16	14
13-16	14	12	12
17-20	12	12	10
21-30	10	10	No

### 11. WEAR PROPER APPAREL.

Do not wear loose clothing, gloves, neckties, rings, bracelets, or other jewelry which may get caught in moving parts. Non-slip footwear is recommended. Wear protective hair covering to contain long hair.

### 12. ALWAYS USE SAFETY GLASSES.

Also use face or dust mask if cutting operation is dusty. Everyday eye-glasses only have impact resistant lenses, they are NOT safety glasses.

### 13. SECURE WORK.

Use clamps or a vise to hold work when practical. It's safer than using your hand and frees both hands to operate tool.

### 14. DON'T OVERREACH.

Keep proper footing and balance at all times.

### 15. MAINTAIN TOOLS WITH CARE.

Keep tools sharp and clean for best and safest performance. Follow instructions for lubricating and changing accessories.

### 16. DISCONNECT TOOLS

before servicing and changing accessories, such as blades, bits, cutters, and the like.

### 17. REDUCE THE RISK OF UNINTENTIONAL STARTING.

Make sure switch is in off position before plugging in.

### 18. USE RECOMMENDED ACCESSORIES.

Consult the owner's manual for recommended accessories. The use of improper accessories may cause risk of injury.

### 19. CHECK DAMAGED PARTS.

Before further use of the tool, a guard or other part that is damaged should be carefully checked to determine that it will operate properly and perform its intended function. Check for alignment of moving parts, binding of moving parts, breakage of parts, mounting, and any other conditions that may affect its operation. A guard or other part that is damaged should be properly repaired or replaced.

### 19. NEVER LEAVE TOOL RUNNING UNATTENDED.

Turn the power off, and don't leave tool until it comes to a complete stop.

### 20. NEVER ALLOW UNTRAINED USERS TO RUN THIS TOOL WHILE UNSUPERVISED.

### 21. IF YOU ARE UNSURE OF THE INTENDED OPERATION, STOP USING THE TOOL.

Seek formal training or research books or magazines that specialize in power tools.

# CONTROL LOCATION

## Control Location

Refer to **Figure 1** for the location of the key components and controls of the machine. These controls are called out later in the manual for their specific use when operating the saw. Become familiar with the controls and all of the adjustments and settings before operating the jig saw.

## Specifications

Speed: Variable from 0-3100 S.P.M.

Motor Type: Universal Brush Motor

Motor Power: 110V, 5.0 Amp

Blade Orbit: 4 Settings

Stroke Length: 1"

Stroke Settings: Variable from 1 to 6

Blade: T-Shank Mounting, 3" - 5"

Blade Guide: Grooved Roller Bearing

Dust Blower: 3 settings

Footplate: Adjustable from +45° to -45°

Weight: 5.5 lbs

Accessories Included: Footplate Wrench & Blade Lock Screwdriver

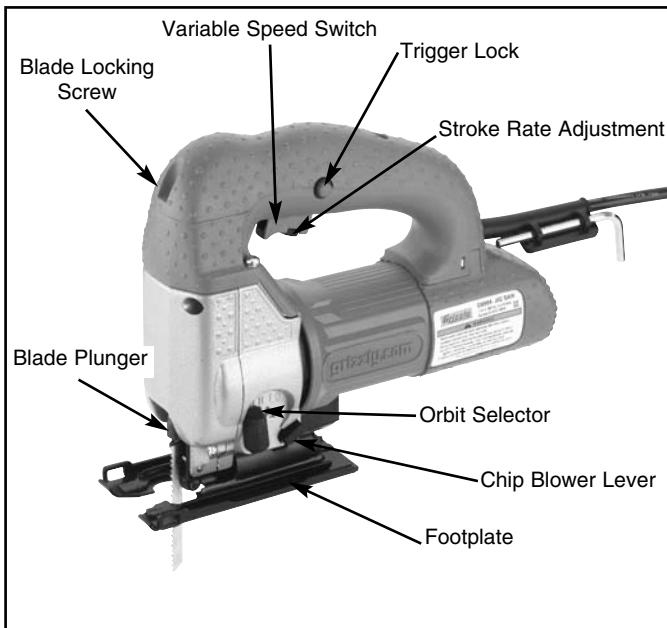

**Fig 1.** Location of controls.

# BLADE SELECTION

---

Always select the correct saw blade for the material being cut. The resulting cut will be cleaner and more accurate, and there will be less stress on the machine. This jig saw can be used to cut wood, metal or plastics depending upon the type of blade selected. The blades used must be of the T-shank style. Grizzly offers a variety of blade styles in the current catalog.

A few points to remember in making your blade selection:

1. The overall blade length will affect the thickness of material which can be cut. Most jig saw blades range in length from 3" to 5".
2. The width of the blade (measured from the tip of one of the teeth to the back edge) affects how tight of a curve can be cut. A  $\frac{3}{16}$ " wide blade will cut a tighter circle than a  $\frac{3}{8}$ " wide one.
3. The number of teeth per inch (T.P.I.) affects the smoothness and speed of the cut. A wood cutting blade for general purpose will usually have 6-10 T.P.I.; a metal cutting will have 12-20 T.P.I. Another factor is the tooth style and how the teeth are set (the amount the tooth is bent away from the plane of the blade). Most blade manufacturers provide guidelines on their packaging for the types of materials and speeds to use for a particular blade style. Review their guidelines carefully before choosing a blade for a particular project.

# BLADE INSTALLATION

## CAUTION

Turn the switch off and unplug the jig saw from the power before attempting blade installation or any adjustments. Serious injury may occur if the unit is accidentally started while installing the blade.

1. Make certain the tool is unplugged while installing the blade.
2. Make sure the orbit selector switch is in Position III. See **Figure 2**.



**Fig 2.** Orbiter selection in Position III.

3. Take the blade and turn it so the teeth are facing the side of the footplate. Insert the mount end into the plunger as shown in **Figure 3**. Twist the blade 90° so the teeth are pointing forward, then pull it down slightly. Make certain the blade is positioned in the groove of the roller which backs up the blade.



**Fig 3.** Inserting blade into plunger.

4. Insert the screwdriver included with this jig saw into the hole at the front of the handle as shown in **Figure 4**. Tighten the screw while making sure the blade stays in the roller groove.



**Fig 4.** Tightening blade locking screw.

5. To remove the blade, reverse the process described above.

# ORBITAL ACTION

The four settings for the orbital action of the blade are controlled by a lever switch. The effect of the settings is shown in **Figure 5**. When set on Position III the blade oscillates forward in the stroke, which is helpful when cutting wood or soft materials. The Position 0 setting eliminates all forward oscillation and the blade strokes

straight up and down. This is good for materials with a strong cutting resistance such as metals and where a very clean cut edge is desired.

Changes in the orbital movement can be made with the motor turned on.

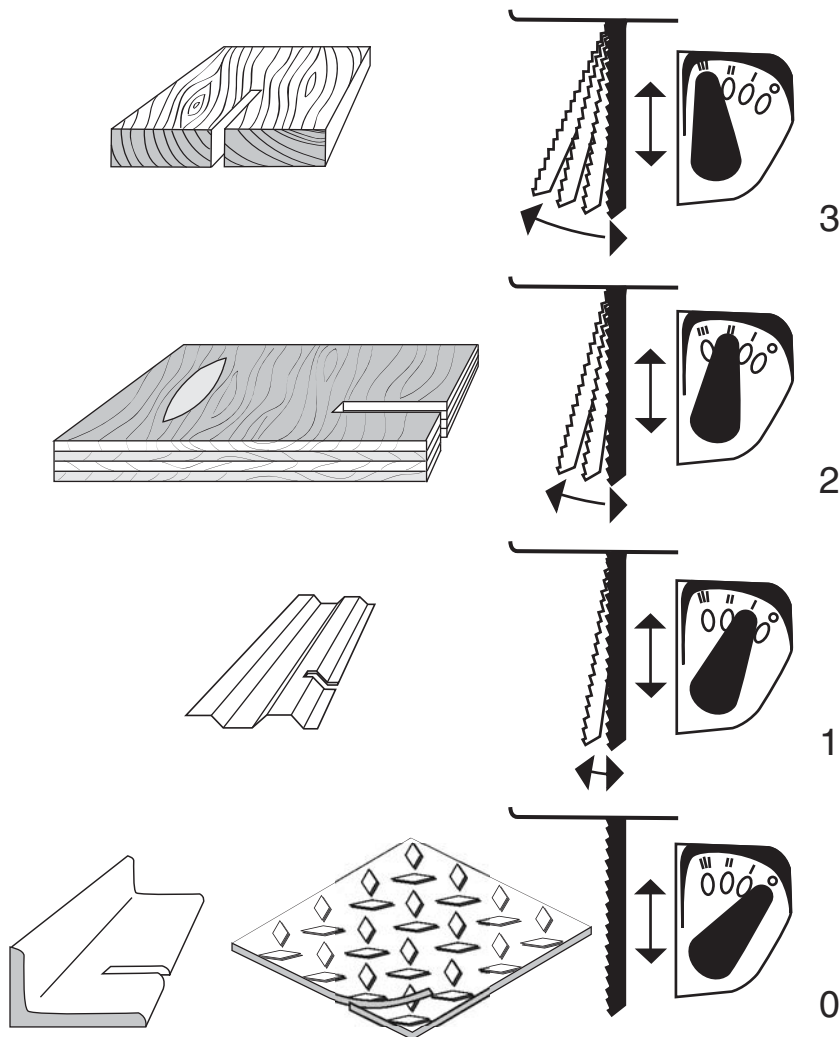

**Fig 5.** Orbital movement settings and typical materials for each selection.



# BLADE SPEED & CHIP BLOWER

## Controlling Blade Speed

Blade speed or stroke rate is controlled by a trigger style switch under the handle. Speed increases as the trigger is pulled. There is also a recessed circular switch in the trigger which controls the maximum stroke rate. See **Figure 6**. The switch is marked with ranges from 1 to 6 where 1 is the lowest stroke rate and 6 is the highest. The adjustment is infinitely variable between settings.

The proper speed depends upon the type of material and the blade. Experiment with a scrap piece of material when first making a cut to see how the cutting action and smoothness is. Adjust the blade speed and the rate of feeding the blade into the work until the action is smooth and the motor does not slow down excessively.

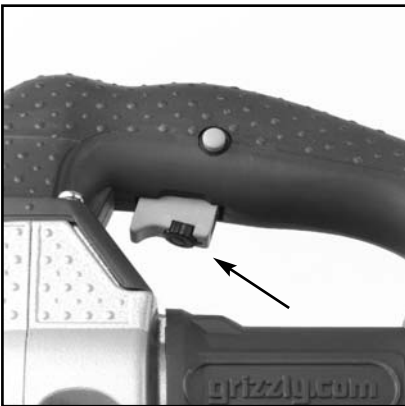

**Fig 6.** Blade speed control switch.

## Setting Chip Blower

The toggle switch next to the orbital movement selector controls the chip blowing device shown in **Figure 7**. When set as shown in the photograph, the amount of air is at its highest level. This is suitable for cutting in wood when it is desirable to blow the sawdust out of the way to see the cut line. There are two additional settings which progressively reduce the amount of air delivered. The lowest setting may be used for cutting in metal where cutting oil is being used and it is not desirable to have air move the oil away from the cutting surface.



**Fig 7.** Chip blower switch.

# FOOTPLATE ADJUSTMENT

The footplate can be adjusted for cutting at 90° to the surface as well as any angle from  $\pm 45^\circ$ . To be certain the footplate is cutting at precisely 90°, it is useful to check the blade squareness to the footplate with the use of a small machinist's square. See **Figure 8**.



**Fig 8.** Checking blade squareness.

To adjust to another angle, use the supplied Allen® wrench to loosen the bolt holding the footplate. Slide the plate forward slightly to disengage it from the notch, and tilt it to the desired angle. At the 45° points, there are notches that position the plate. By pushing the plate back when near 45°, the notches will lock the plate in position. If an angle between 90° and 45° is desired, set the angle and leave the plate in the forward position, then tighten the bolt. See **Figure 9**.



**Fig 9.** Setting footplate for angle cuts.

The footplate can also be set to accommodate flush cutting. This might be used when it is desirable to cut right up to a wall or other vertical surface. Remove the bolt holding the footplate with the Allen® wrench. Slide the plate backward so the mounting hole lines up with the rearmost mounting hole. Reinstall and tighten the bolt. The front edge of the footplate will be slightly behind the leading edge of the blade as shown in **Figure 10**.



**Fig 10.** Footplate positioned for flush cutting.

# OPERATING TIPS AND MAINTENANCE

---

## Operating Guides and Tips

**Avoid overloading the jig saw.** Do not apply excessive pressure to the tool while using. If the speed drops abnormally, decrease pressure immediately.

**Ensure a safe workplace.** Clear the work area of all parts and debris that may cause injury by flying objects. Securely fix the workpiece in a vise or otherwise clamp to avoid injury. Do not attempt to hold the workpiece by hand.

**Inspect the tool before use.** Run the tool free of the workpiece before using to ensure all parts are running smooth and there are no abnormal sounds or sparks. If any defect is found, have the unit serviced.

**Know your work site.** Take care to make sure the workpiece is not supporting another structure or that there are no obstructions. Before cutting into walls, check for wires, other electrical hazards, or plumbing which may be hidden in the wall space.

### **WARNING**

Operating this equipment has the potential to propel debris into the air which can cause eye injury. Always wear safety glasses or goggles when operating equipment. Be certain the safety glasses you wear meet the appropriate standards of the American National Standards Institute (ANSI).

## Maintenance

Your 110 V jig saw will give you hundreds of hours of operation time before ever needing service. The electrical components of this saw are not user serviceable. This product is double insulated which provides protection from electrical shock should a problem ever develop with grounding. Great care must be taken whenever servicing double insulated equipment to make certain the repair does not destroy the insulated properties. Service should be performed only by a qualified electrical technician.

Keep the saw free from dirt and grease. Always store it in a dry place.

### **WARNING**

Disassembly and improper reassembly of this device can result in electrical shock danger. Always have this device serviced by a qualified electrical repair technician. Serious injury will result.

# NOTES

---

---

# WARRANTY AND RETURNS

---

Grizzly Industrial, Inc. warrants every product it sells for a period of **1 year** to the original purchaser from the date of purchase. This warranty does not apply to defects due directly or indirectly to misuse, abuse, negligence, accidents, repairs or alterations or lack of maintenance. This is Grizzly's sole written warranty and any and all warranties that may be implied by law, including any merchantability or fitness, for any particular purpose, are hereby limited to the duration of this written warranty. We do not warrant or represent that the merchandise complies with the provisions of any law or acts unless the manufacturer so warrants. In no event shall Grizzly's liability under this warranty exceed the purchase price paid for the product and any legal actions brought against Grizzly shall be tried in the State of Washington, County of Whatcom.

We shall in no event be liable for death, injuries to persons or property or for incidental, contingent, special, or consequential damages arising from the use of our products.

To take advantage of this warranty, contact us by mail or phone and give us all the details. We will then issue you a "Return Number," which must be clearly posted on the outside as well as the inside of the carton. We will not accept any item back without this number. Proof of purchase must accompany the merchandise.

The manufacturers reserve the right to change specifications at any time because they constantly strive to achieve better quality equipment. We make every effort to ensure that our products meet high quality and durability standards and we hope you never need to use this warranty.

Please feel free to write or call us if you have any questions about the machine or the manual.

Grizzly Industrial, Inc.  
2406 Reach Road  
Williamsport, PA 17701  
Phone: (570) 546-9663  
Fax: (800) 438-5901

E-Mail:  
[techsupport@grizzly.com](mailto:techsupport@grizzly.com)

Web Site: <http://www.grizzly.com>

Address after fall 2001:

Grizzly Industrial, Inc  
1203 Lycoming Circle  
Pennsdale, PA 17756

Thank you again for your business and continued support. We hope to serve you again soon.

G8994Z Variable Speed Jig Saw

-11-

# WARRANTY CARD

Name \_\_\_\_\_

Street \_\_\_\_\_

City \_\_\_\_\_ State \_\_\_\_\_ Zip \_\_\_\_\_

Phone Number \_\_\_\_\_ E-Mail \_\_\_\_\_ FAX \_\_\_\_\_

MODEL # G8994Z 110V Jig Saw Order # \_\_\_\_\_

The following information is given on a voluntary basis. It will be used for marketing purposes to help us develop better products and services. Of course, all information is strictly confidential.

- How did you learn about us?  
 Advertisement  Friend  
 Catalog  Card Deck  
 World Wide Web  
 Other \_\_\_\_\_
- What is your annual household income?  
 \$20,000-\$29,999  \$60,000-\$69,999  
 \$30,000-\$39,999  \$70,000-\$79,999  
 \$40,000-\$49,999  \$80,000-\$89,999  
 \$50,000-\$59,999  \$90,000 +
- What is your age group?  
 20-29  50-59  
 30-39  60-69  
 40-49  70 +
- How long have you been a woodworker?  
 0 - 2 Years  8 - 20 Years  
 2 - 8 Years  20+ Years
- How would you rank your woodworking skills?  
 Simple  Advanced  
 Intermediate  Master Craftsman
- What stationary woodworking tools do you own?  
Check all that apply.  
 Air Compressor  Panel Saw  
 Band Saw  Planer  
 Drill Press  Power Feeder  
 Drum Sander  Radial Arm Saw  
 Dust Collector  Shaper  
 Spindle Sander  Jointer  
 Table Saw  Lathe  
 Mortiser  Wide Belt Sander  
 Horizontal Boring Machine  
 Vacuum Veneer Press  
 Other \_\_\_\_\_
- How many of your woodworking machines are Grizzly? \_\_\_\_\_
- Which benchtop tools do you own? Check all that apply.  
 1"x42" Belt Sander  6" - 8" Grinder  
 5" - 8" Drill Press  Mini Lathe  
 8" Table Saw  8" - 10" Bandsaw  
 Scroll Saw  Disc/Belt Sander  
 Spindle/Belt Sander  Mini Jointer  
 10"-12" Thickness Planer  
 Other \_\_\_\_\_
- How many of the machines checked above are Grizzly? \_\_\_\_\_
- Which portable/hand held power tools do you own?  
Check all that apply.  
 Belt Sander  Orbital Sander  
 Biscuit Joiner  Palm Sander  
 Circular Saw  Portable Planer  
 Detail Sander  Saber Saw  
 Drill/Driver  Reciprocating Saw  
 Miter Saw  Router  
 Other \_\_\_\_\_
- What machines/supplies would you like Grizzly Industrial to carry?  
 12" Table Saw  Radial Arm Saw  
 12" Jointer  Panel Saw  
 Brass Hardware  Lumber  
 Paint & Finishing Supplies  
 Contractor's Supplies  
 Combination Planer/Jointer  
 Other \_\_\_\_\_
- What new accessories would you like Grizzly Industrial to carry?  
 Builders Hardware  Hand Tools  
 Fasteners  
 Wood Components  
 Other \_\_\_\_\_
- What other companies do you purchase your tools and supplies from?  
\_\_\_\_\_  
\_\_\_\_\_  
\_\_\_\_\_
- Do you think your purchase represents good value?  
 Yes  No
- Would you recommend Grizzly to a friend?  
 Yes  No
- Would you allow us to use your name as a reference for Grizzly customers in your area? **Note: We never use names more than three times.**  
 Yes  No
- Comments: \_\_\_\_\_  
\_\_\_\_\_  
\_\_\_\_\_

Send a Grizzly Catalog to a friend:

Name_____
Street_____
City_____State_____Zip_____

FOLD ALONG DOTTED LINE

---

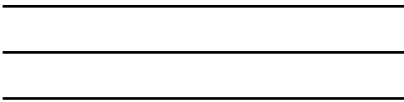

**GRIZZLY INDUSTRIAL, INC.**  
**P.O. BOX 2069**  
**BELLINGHAM, WA 98227-2069**

TAPE ALONG EDGES--PLEASE DO NOT STAPLE

## Free Manuals Download Website

<http://myh66.com>

<http://usermanuals.us>

<http://www.somanuals.com>

<http://www.4manuals.cc>

<http://www.manual-lib.com>

<http://www.404manual.com>

<http://www.luxmanual.com>

<http://aubethermostatmanual.com>

Golf course search by state

<http://golfingnear.com>

Email search by domain

<http://emailbydomain.com>

Auto manuals search

<http://auto.somanuals.com>

TV manuals search

<http://tv.somanuals.com>