

Grizzly *Industrial, Inc.*®

MODEL G0674 12" SLIDING TABLE SAW OWNER'S MANUAL



COPYRIGHT © NOVEMBER, 2008. BY GRIZZLY INDUSTRIAL, INC.
**WARNING: NO PORTION OF THIS MANUAL MAY BE REPRODUCED IN ANY SHAPE
OR FORM WITHOUT THE WRITTEN APPROVAL OF GRIZZLY INDUSTRIAL, INC.**
#JB11253 PRINTED IN GERMANY



WARNING!

This manual provides critical safety instructions on the proper setup, operation, maintenance and service of this machine/equipment.

Failure to read, understand and follow the instructions given in this manual may result in serious personal injury, including amputation, electrocution or death.

The owner of this machine/equipment is solely responsible for its safe use. This responsibility includes but is not limited to proper installation in a safe environment, personnel training and usage authorization, proper inspection and maintenance, manual availability and comprehension, application of safety devices, blade/cutter integrity, and the usage of personal protective equipment.

The manufacturer will not be held liable for injury or property damage from negligence, improper training, machine modifications or misuse.



WARNING!

Some dust created by power sanding, sawing, grinding, drilling, and other construction activities contains chemicals known to the State of California to cause cancer, birth defects or other reproductive harm. Some examples of these chemicals are:

- **Lead from lead-based paints.**
- **Crystalline silica from bricks, cement and other masonry products.**
- **Arsenic and chromium from chemically-treated lumber.**

Your risk from these exposures varies, depending on how often you do this type of work. To reduce your exposure to these chemicals: Work in a well ventilated area, and work with approved safety equipment, such as those dust masks that are specially designed to filter out microscopic particles.

Table of Contents

INTRODUCTION.....	2	SECTION 5: ACCESSORIES.....	42
Manual Accuracy	2	Shop Made Safety Accessories.....	44
Contact Info.....	2	SECTION 6: MAINTENANCE.....	45
Functional Overview	2	Schedule	45
Identification.....	3	Cleaning.....	45
Machine Data Sheet	4	Unpainted Cast Iron.....	45
SECTION 1: SAFETY.....	7	Lubrication	46
Safety Instructions for Machinery	7	SECTION 7: SERVICE	47
Additional Safety for Table Saws.....	9	Troubleshooting	47
Preventing Kickback	10	Belt Service.....	49
Protecting Yourself From Kickback.....	10	Blade Tilt Calibration.....	52
Glossary of Terms	11	Indicator Calibration.....	53
SECTION 2: CIRCUIT REQUIREMENTS	12	Sliding Table Parallel Adjustment.....	54
220V Operation.....	12	Squaring Crosscut Fence to Blade.....	55
SECTION 3: SETUP.....	13	SECTION 8: WIRING.....	56
Setup Safety	13	Wiring Safety Instructions	56
Unpacking.....	13	Wiring Overview.....	57
Items Needed for Setup.....	13	Electrical Box Photos.....	58
Inventory	14	Wiring (Electrical Boxes)	59
Hardware Recognition Chart	16	Wiring (Components).....	60
Clean Up.....	17	SECTION 9: PARTS.....	61
Site Considerations.....	17	Tables Breakdown	61
Moving & Placing Saw Base Unit	18	Cabinet Breakdown.....	62
Assembly & Setup	19	Cabinet Parts List	63
Test Run	25	Control Components Breakdown.....	64
SECTION 4: OPERATIONS	27	Trunnion Breakdown.....	65
Basic Controls.....	27	Trunnion Parts List.....	66
Safety Tips.....	29	Scoring Blade Breakdown	67
Blade Selection.....	30	Accessory Breakdown	68
Changing Main Blade	31	Accessory List.....	69
Blade Guard Assembly	32	Outrigger Breakdown.....	70
Riving Knife.....	33	Crosscut Table Breakdown.....	71
Riving Knife Adjustment.....	34	Extension Fence Breakdown	72
Workpiece Inspection.....	35	Electrical Components Breakdown.....	73
Non-Through & Through Cuts	35	Labels Breakdown	74
Adjusting and Replacing Scoring Blade	36	WARRANTY AND RETURNS	77
Rip Cutting	37		
Crosscutting.....	39		
Miter Cutting.....	41		

INTRODUCTION

Manual Accuracy

We are proud to offer this manual with your new machine! We've made every effort to be exact with the instructions, specifications, drawings, and photographs of the machine we used when writing this manual. However, sometimes errors do happen and we apologize for them.

Also, owing to our policy of continuous improvement, **your machine may not exactly match the manual.** If you find this to be the case, and the difference between the manual and machine leaves you in doubt, immediately call our technical support for updates or clarification.

For your convenience, we always keep current Grizzly manuals and most updates available on our website at www.grizzly.com. Any updates to your machine will be reflected in these documents as soon as they are complete. Visit our site often to check for the latest updates!

Contact Info

We stand behind our machines. If you have any service questions, parts requests or general questions about the machine, please call or write us at the location listed below.

Grizzly Industrial, Inc.
1203 Lycoming Mall Circle
Muncy, PA 17756
Phone: (570) 546-9663
Fax: (800) 438-5901
E-Mail: techsupport@grizzly.com

If you have any comments regarding this manual, please write to us at the address below:

Grizzly Industrial, Inc.
c/o Technical Documentation Manager
P.O. Box 2069
Bellingham, WA 98227-2069
Email: manuals@grizzly.com

Functional Overview

A sliding table saw is primarily used to rip and crosscut sheet stock or panels in a production setting. The sliding table makes it much easier and safer to feed these large workpieces through a cut. This saw can also be used as a traditional table saw for most types of through-cuts.

The primary components of a sliding table saw are the sliding table, the fixed table, the crosscut table and fence, the rip fence, the main blade and the scoring blade.

A typical cut using the sliding table is made by placing the workpiece on the sliding table and crosscut table, positioning it against the crosscut fence where needed, and pushing the workpiece through the blade by sliding the table.

The Model G0674 is equipped with a scoring blade, which is a smaller blade located in front of the main blade. It makes a shallow cut in the workpiece in the opposite direction of the main blade, greatly reducing tear-out. The scoring blade may be used if tear-out free cuts are required. If the scoring blade is not needed for cutting operations, it can be lowered under the table to reduce wear.

When using the sliding table saw as a traditional table saw, the sliding table is locked in place and the rip fence is then used to guide the workpiece through the cut.



Identification

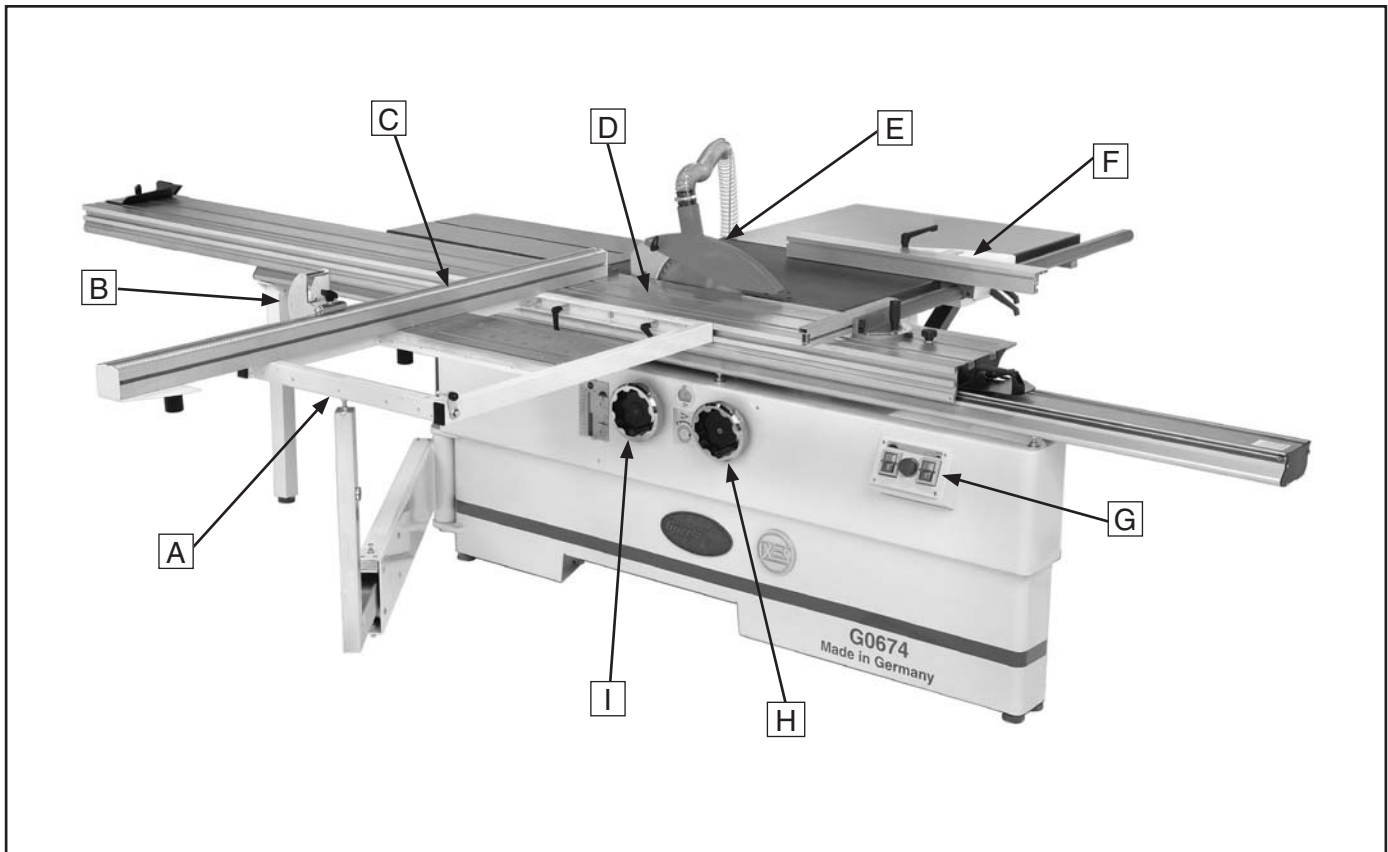


Figure 1. Main view of machine features and controls.

- A. Crosscut Table**—Provides a wide, stable platform for supporting full-size panels during crosscutting operations.
- B. Flip Stop**—Used for quick measurements for crosscutting.
- C. Crosscut Fence**—Used during crosscutting operations. Features a scale and multiple flip-style stop blocks for precise, repeatable crosscutting operations.
- D. Sliding Table**—Conveniently glides the workpiece through the blade with effortless precision and ease.
- E. Blade Guard**—Fully-adjustable blade guard maintains maximum protection around the saw blade and a 2½" dust port effectively extracts dust from the cutting operation.
- F. Rip Fence**—Fully adjustable with micro-adjustment knob for precision adjustments. Fence face can be positioned for standard cutting operations, or in the lower position for blade guard clearance during narrow ripping operations.
- G. Control Panel**—Features push-button controls for operating the many features of the saw.
- H. Blade Angle Handwheel**—Adjusts the angle of the saw blades.
- I. Blade Elevation Handwheel**—Adjusts the height of the main saw blade.



MACHINE DATA SHEET

Customer Service #: (570) 546-9663 • To Order Call: (800) 523-4777 • Fax #: (800) 438-5901

MODEL G0674 SLIDING TABLE SAW

Product Dimensions:

Weight	937 lbs.
Length/Width/Height	133 ⁷ / ₈ " x 41 ¹ / ₂ " x 43 ³ / ₄ "
Footprint with Legs (Width/Depth)	72 ⁷ / ₈ " x 33 ¹ / ₂ "
Cabinet Footprint (Width/Depth)	74 ¹ / ₂ " x 35 ¹ / ₂ "
Table Size without Extension Wings (Length/Width)	32" x 23 ⁵ / ₈ "
Table Size with Extension Wings (Length/Width)	65 ⁵ / ₈ " x 53 ¹ / ₂ "
Sliding Table Size (Length/Width)	126" x 12 ¹ / ₄ "
Crosscut Fence Size (Length/Width)	110 ¹ / ₄ " x 2 ³ / ₄ "

Shipping Dimensions:

Number of Crates.....	2
Crate 1 Type	Wood
Crate 1 Content.....	Machine
Crate 1 Length/Width/Height.....	86 ⁵ / ₈ " x 45 ¹ / ₄ " x 43 ³ / ₈ "
Crate 1 Weight.....	1051 lbs.
Crate 2 Type	Wood
Crate 2 Content.....	Sliding Table
Crate 2 Length/Width/Height.....	135 ⁷ / ₈ " x 15 ³ / ₄ " x 9 ⁷ / ₈ "
Crate 2 Weight.....	231 lbs.

Electrical:

Switch Type	Magnetic Switch w/ON & OFF Buttons
Switch Voltage	220V
Cord Provided	No
Recommended Cord for 220V	10 gauge, 4 Wire, 300VAC
Minimum 220V Circuit Size.....	30A
Recommended Plug Type for 220V.....	L15-30

Motor

Main Motor

Type.....	Induction Motor
Horsepower	6.5 HP
Voltage	220V
Prewired	220V
Phase	3-Phase
Amps	16A
Speed	3450 RPM
Cycle.....	60 Hz
Number Of Speeds.....	1
Power Transfer.....	Poly V-Belt
Bearings	Shielded and Permanently Sealed



Scoring Motor

Type.....	Induction Motor
Horsepower	1 HP
Voltage	220V
Phase	1-Phase
Amps	3A
Speed	3450 RPM
Cycle.....	60 Hz
Number Of Speeds.....	1
Power Transfer.....	Direct Drive
Bearings	Shielded and Permanently Sealed

Main Specifications:

Capacities

Main Blade Arbor Diameter	1¼"
Main Blade Arbor Speed	4000 RPM
Main Blade Diameter	12"
Maximum Depth Of Cut At 90°	4¼"
Maximum Depth Of Cut At 45°	3"
Blade Tilt	0° – 45°
Maximum Ripping Width With Standard Rip Fence.....	22 ⁷ / ₈ "
Maximum Cross Cutting Width With Crosscut Fence	109 ⁷ / ₈ "
Maximum Cross Cutting Length With Crosscut Fence	124"
Scoring Blade Arbor Diameter¾" (20mm)
Scoring Blade Arbor Speed.....	9500 RPM
Scoring Blade Diameter	4¾" (120mm)

Construction

Sliding Table.....	Anodized Aluminum
Machine Frame	Steel
Fences.....	Aluminum
Rails.....	Steel
Trunnions.....	Cast Iron
Arbor Bearings	Shielded and Permanently Sealed

Other Specifications:

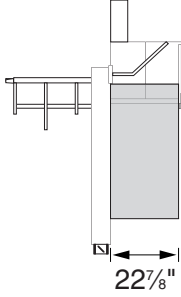
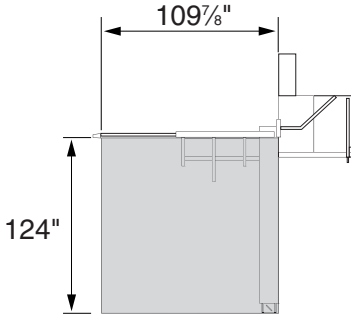
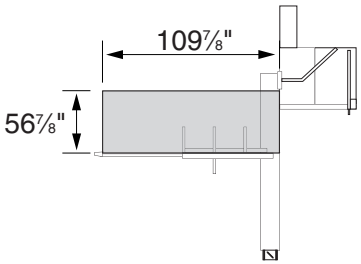
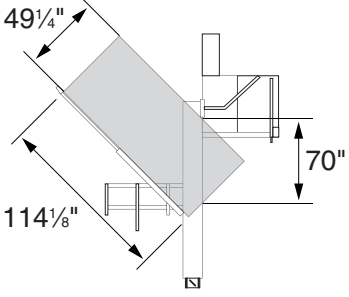
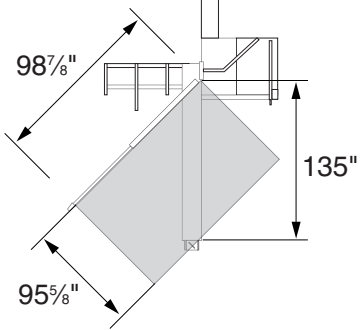
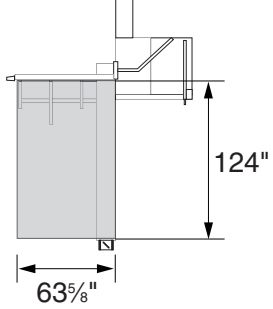
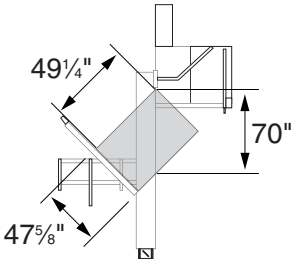
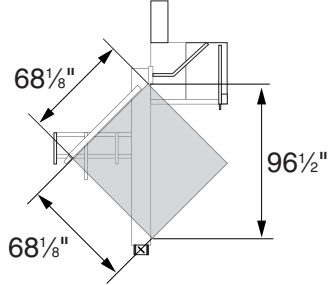
Country Of Origin	Germany
Warranty.....	1 Year
Serial Number Location	Machine ID Label on Front of Machine
Customer Assembly & Setup Time.....	3 hrs.
Dust Port Size	4"
Minimum Required CFM at Dust Port.....	400 CFM
Sound Rating	90 dB

Features:

- Patented cast iron trunnion system
- Sliding table is made of anodized aluminum and travels on hardened prismatic bearings
- Blades tilt to 45° for bevel cutting
- Poly V-belt drive mechanism ensures maximum power transmission
- Includes 12" tungsten carbide-tipped blade
- Super heavy cast-iron main table
- 4" Dust port



MODEL G0674 SLIDING TABLE SAW

<p>Ripping Width</p>  <p>22⁷/₈"</p>	<p>Cross Cut</p>  <p>109⁷/₈"</p> <p>124"</p>
<p>Miter Cut 90° (push cut)</p>  <p>109⁷/₈"</p> <p>56⁷/₈"</p>	<p>Miter Cut 45° (push cut)</p>  <p>49¹/₄"</p> <p>114¹/₈"</p> <p>70"</p>
<p>Miter Cut 45°</p>  <p>98⁷/₈"</p> <p>135"</p> <p>95⁵/₈"</p>	<p>Cross Cut (fence not extended)</p>  <p>124"</p> <p>63⁵/₈"</p>
<p>Miter Cut 45° (push cut, fence not extended)</p>  <p>49¹/₄"</p> <p>70"</p> <p>47⁷/₈"</p>	<p>Miter Cut 45° (fence not extended)</p>  <p>68¹/₈"</p> <p>96¹/₂"</p> <p>68¹/₈"</p>

SECTION 1: SAFETY


WARNING

For Your Own Safety, Read Instruction Manual Before Operating this Machine

The purpose of safety symbols is to attract your attention to possible hazardous conditions. This manual uses a series of symbols and signal words intended to convey the level of importance of the safety messages. The progression of symbols is described below. Remember that safety messages by themselves do not eliminate danger and are not a substitute for proper accident prevention measures.

 **DANGER** Indicates an imminently hazardous situation which, if not avoided, WILL result in death or serious injury.

 **WARNING** Indicates a potentially hazardous situation which, if not avoided, COULD result in death or serious injury.

 **CAUTION** Indicates a potentially hazardous situation which, if not avoided, MAY result in minor or moderate injury. It may also be used to alert against unsafe practices.

NOTICE This symbol is used to alert the user to useful information about proper operation of the machine.

WARNING

Safety Instructions for Machinery

- 1. READ THE ENTIRE MANUAL BEFORE STARTING MACHINERY.** Machinery presents serious injury hazards to untrained users.
- 2. ALWAYS USE ANSI APPROVED SAFETY GLASSES WHEN OPERATING MACHINERY.** Everyday eyeglasses only have impact resistant lenses—they are NOT safety glasses.
- 3. ALWAYS WEAR A NIOSH APPROVED RESPIRATOR WHEN OPERATING MACHINERY THAT PRODUCES DUST.** Most types of dust (wood, metal, etc.) can cause severe respiratory illnesses.
- 4. ALWAYS USE HEARING PROTECTION WHEN OPERATING MACHINERY.** Machinery noise can cause permanent hearing loss.
- 5. WEAR PROPER APPAREL. DO NOT** wear loose clothing, gloves, neckties, rings, or jewelry that can catch in moving parts. Wear protective hair covering to contain long hair and wear non-slip footwear.
- 6. NEVER OPERATE MACHINERY WHEN TIRED OR UNDER THE INFLUENCE OF DRUGS OR ALCOHOL.** Be mentally alert at all times when running machinery.



WARNING

Safety Instructions for Machinery

7. **ONLY ALLOW TRAINED AND PROPERLY SUPERVISED PERSONNEL TO OPERATE MACHINERY.** Make sure operation instructions are safe and clearly understood.
8. **KEEP CHILDREN AND VISITORS AWAY.** Keep all children and visitors a safe distance from the work area.
9. **MAKE WORKSHOP CHILDPROOF.** Use padlocks, master switches, and remove start switch keys.
10. **NEVER LEAVE WHEN MACHINE IS RUNNING.** Turn power **OFF** and allow all moving parts to come to a complete stop before leaving machine unattended.
11. **DO NOT USE IN DANGEROUS ENVIRONMENTS.** DO NOT use machinery in damp, wet locations, or where any flammable or noxious fumes may exist.
12. **KEEP WORK AREA CLEAN AND WELL LIGHTED.** Clutter and dark shadows may cause accidents.
13. **USE A GROUNDED EXTENSION CORD RATED FOR THE MACHINE AMPERAGE.** Grounded cords minimize shock hazards. Undersized cords create excessive heat. Always replace damaged extension cords.
14. **ALWAYS DISCONNECT FROM POWER SOURCE BEFORE SERVICING MACHINERY.** Make sure switch is in OFF position before reconnecting.
15. **MAINTAIN MACHINERY WITH CARE.** Keep blades sharp and clean for best and safest performance. Follow instructions for lubricating and changing accessories.
16. **MAKE SURE GUARDS ARE IN PLACE AND WORK CORRECTLY BEFORE USING MACHINERY.**
17. **REMOVE ADJUSTING KEYS AND WRENCHES.** Make a habit of checking for keys and adjusting wrenches before turning machinery **ON**.
18. **CHECK FOR DAMAGED PARTS BEFORE USING MACHINERY.** Check for binding or misaligned parts, broken parts, loose bolts, and any other conditions that may impair machine operation. Repair or replace damaged parts before operation.
19. **USE RECOMMENDED ACCESSORIES.** Refer to the instruction manual for recommended accessories. Improper accessories increase risk of injury.
20. **DO NOT FORCE MACHINERY.** Work at the speed for which the machine or accessory was designed.
21. **SECURE WORKPIECE.** Use clamps or a vise to hold the workpiece when practical. A secured workpiece protects your hands and frees both hands to operate the machine.
22. **DO NOT OVERREACH.** Maintain stability and balance at all times.
23. **MANY MACHINES CAN EJECT WORKPIECES TOWARD OPERATOR.** Know and avoid conditions that cause the workpiece to "kickback."
24. **ALWAYS LOCK MOBILE BASES (IF USED) BEFORE OPERATING MACHINERY.**
25. **CERTAIN DUST MAY BE HAZARDOUS** to the respiratory systems of people and animals, especially fine dust. Be aware of the type of dust you are exposed to and always wear a respirator designed to filter that type of dust.



WARNING

Additional Safety for Table Saws

- 1. SAFETY ACCESSORIES.** Always use the blade guard and riving knife on all "through-sawing" operations. *Through-sawing operations are those when the blade cuts completely through the workpiece.*
- 2. KICKBACK.** Be familiar with kickback. Kickback happens when the workpiece is thrown towards the operator at a high rate of speed. *Until you have a clear understanding of kickback and how it occurs, DO NOT operate this table saw!*
- 3. WORKPIECE CONTROL.** Make sure the workpiece is placed in a stable position on the table and is either supported by the rip fence or the crosscut table during cutting operations.
- 4. PUSH STICK.** Always use a push stick when ripping narrow stock.
- 5. OPERATOR POSITION.** Never stand or have any part of your body directly in-line with the cutting path of the saw blade.
- 6. AWKWARD OPERATIONS.** Avoid awkward operations and hand positions where a sudden slip could cause your hand to move into the spinning saw blade.
- 7. RIVING KNIFE ALIGNMENT.** Only operate the saw if the riving knife is aligned with the main blade.
- 8. REACHING OVER SAW BLADE.** Never reach behind or over the blade with either hand while the saw is running. *If kickback occurs while reaching over the blade, hands or arms will be pulled into the spinning saw blade.*
- 9. RIP FENCE AND CROSSCUT FENCE USAGE.** When using the rip fence as a stop block for the crosscut fence, the rip fence must be in front of the blade.
- 10. CUT-OFF WORKPIECES.** Turn saw **OFF** before removing workpiece cut-offs.
- 11. BLADE HEIGHT.** Always adjust the blade to the proper height above the workpiece.
- 12. DAMAGED SAW BLADES.** Never use blades that have been dropped or otherwise damaged.
- 13. EXPERIENCING DIFFICULTIES.** If at any time you are experiencing difficulties performing the intended operation, stop using the machine! Contact our Service Department at (570) 546-9663.

WARNING

Like all machines there is danger associated with the Model G0674. Accidents are frequently caused by lack of familiarity or failure to pay attention. Use this machine with respect and caution to lessen the possibility of operator injury. If normal safety precautions are overlooked or ignored, serious personal injury may occur.

CAUTION

No list of safety guidelines can be complete. Every shop environment is different. Always consider safety first, as it applies to your individual working conditions. Use this and other machinery with caution and respect. Failure to do so could result in serious personal injury, damage to equipment, or poor work results.



Preventing Kickback

Below are tips to avoid the most common causes of kickback:

- Only cut workpieces with at least one smooth and straight edge. DO NOT cut excessively warped, cupped or twisted wood. If the workpiece warpage is questionable, always choose another workpiece.
- Never attempt freehand cuts. If the workpiece is not fed parallel with the blade, a kickback will likely occur. Always use the rip fence or cross cut fence to support the workpiece.
- Make sure the riving knife is aligned with the blade. A misaligned riving knife can cause the workpiece to catch or bind, increasing the chance of kickback. If you think that your riving knife is not aligned with the blade, check it immediately!
- Ensure that your table slides parallel with the blade; otherwise, the chances of kickback are extreme. Take the time to check and adjust the sliding table.
- Do not remove the riving knife. The riving knife maintains the kerf in the workpiece, reducing the chance of kickback.
- Keep the blade guard installed and in good working order.
- Feed cuts through to completion. Anytime you stop feeding a workpiece in the middle of a cut, the chance of kickback is greatly increased.

WARNING

Statistics show that most common accidents among table saw users can be linked to kickback. Kickback is typically defined as the high-speed expulsion of stock from the table saw toward its operator. In addition to the danger of the operator or others in the area being struck by the flying stock, it is often the case that the operator's hands are pulled into the blade during the kickback.

Protecting Yourself From Kickback

Even if you know how to prevent kickback, it may still happen. Here are some tips to protect yourself if kickback DOES occur:

- Stand to the side of the blade during every cut. If a kickback does occur, the thrown workpiece usually travels directly in front of the blade.
- Wear safety glasses or a face shield. In the event of a kickback, your eyes and face are the most vulnerable part of your body.
- Never, for any reason, place your hand behind the blade. Should kickback occur, your hand will be pulled into the blade.
- Use a push stick to keep your hands farther away from the moving blade. If a kickback occurs, the push stick will most likely take the damage that your hand would have received.
- Use featherboards or anti-kickback devices to prevent or slow down kickback.



Glossary of Terms

The following is a list of common definitions, terms and phrases used throughout this manual as they relate to this table saw and woodworking in general. Become familiar with these terms for assembling, adjusting or operating this machine. Your safety is **VERY** important to us at Grizzly!

Arbor: Metal shaft extending from the drive mechanism, to which saw blade is mounted.

Bevel Edge Cut: Tilting the arbor and saw blade to an angle between 0° and 45° to cut a beveled edge onto a workpiece.

Blade Guard: Metal or plastic safety device that mounts over the saw blade. Its function is to prevent the operator from coming into contact with the saw blade.

Crosscut: Cutting operation in which the cross-cut fence is used to cut across the grain, or across the shortest width of the workpiece.

Dado Blade: Blade or set of blades that are used to cut grooves and rabbets.

Dado Cut: Cutting operation that uses a standard or dado blade to cut a flat bottomed groove into the face of the workpiece.

Featherboard: Safety device used to keep the workpiece against the rip fence and against the table surface.

Kerf: The resulting cut or gap in the workpiece after the saw blade passes through during a cutting operation.

Kickback: An event in which the workpiece is propelled back towards the operator at a high rate of speed.

Parallel: Being an equal distance apart at every point along two given lines or planes. I.e. the rip fence face is parallel to the face of the saw blade.

Non-Through Cut: A sawing operation that requires the removal of the blade guard and riving knife. Dado and rabbet cuts are considered Non-Through Cuts because the blade does not protrude above the top face of the wood stock. Deep Non-Through Cuts must be made with multiple, light passes to reduce chance of kickback. Always remember to re-install the blade guard and riving knife after performing a non-through cut.

Perpendicular: Lines or planes that intersect and form right angles (i.e. the blade is perpendicular to the table surface).

Push Stick: Safety device used to push the workpiece through a cutting operation. Used most often when rip cutting thin workpieces.

Rabbet: Cutting operation that creates an L-shaped channel along the edge of the workpiece.

Rip Cut: Cutting operation in which the rip fence is used to cut with the grain, or across the widest width of the workpiece.

Riving Knife (Splitter): Metal plate located behind the blade. It maintains the kerf opening in the wood when performing a through-cutting operation.

Straightedge: A tool used to check the flatness, parallelism, or consistency of a surface(s).

Through Cut: A sawing operation in which the workpiece is completely sawn through.

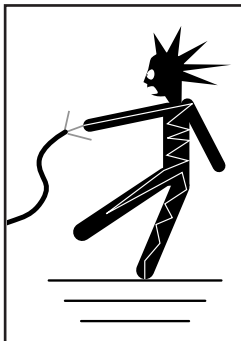


SECTION 2: CIRCUIT REQUIREMENTS

220V Operation

!WARNING

Serious personal injury could occur if you connect the machine to power before completing the setup process. **DO NOT** connect the machine to the power until instructed later in this manual.



!WARNING

Electrocution or fire could result if machine is not grounded and installed in compliance with electrical codes. Compliance **MUST** be verified by a qualified electrician!

Full Load Amperage Draw

This machine draws the following amps under maximum load:

Amp Draw..... 19 Amps

Power Supply Circuit Requirements

You **MUST** connect your machine to a grounded circuit that is rated for the amperage given below. Never replace a circuit breaker on an existing circuit with one of higher amperage without consulting a qualified electrician to ensure compliance with wiring codes. **If you are unsure about the wiring codes in your area or you plan to connect your machine to a shared circuit, consult a qualified electrician.**

Minimum Circuit Size..... 30 Amps

Power Connection Device

The type of plug required to connect your machine to power depends on the type of service you currently have or plan to install. We recommend using the plug shown in **Figure 2**.

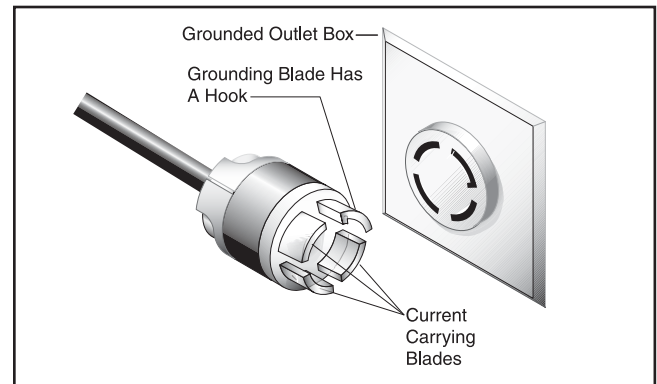


Figure 2. NEMA L15-30 plug and receptacle.

Extension Cords

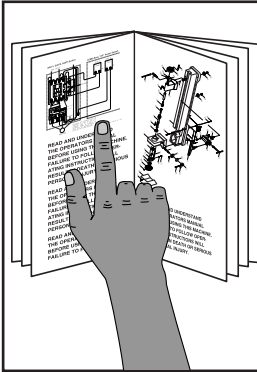
Using extension cords may reduce the life of the motor. Instead, place the machine near a power source. If you must use an extension cord:

- Use at least a 10 gauge cord that does not exceed 50 feet in length!
- The extension cord must also have a ground wire and plug pin.
- A qualified electrician **MUST** size cords over 50 feet long to prevent motor damage.

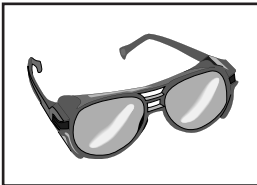


SECTION 3: SETUP

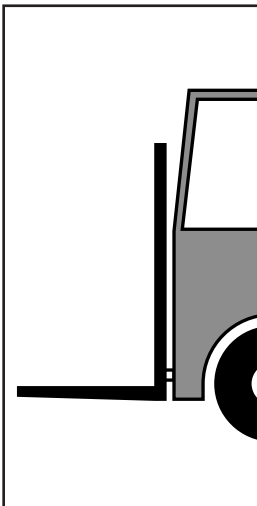
Setup Safety



!WARNING
This machine presents serious injury hazards to untrained users. Read through this entire manual to become familiar with the controls and operations before starting the machine!



!WARNING
Wear safety glasses during the entire set up process!



!WARNING
The Model G0674 is a heavy machine that weighs over 900 lbs. Serious personal injury may occur if safe moving methods are not followed. To be safe, you will need assistance and power equipment when moving the shipping crate and removing the machine from the crate.

Unpacking

The Model G0674 was carefully packed when it left our warehouse. If you discover the machine is damaged after you have signed for delivery, please immediately call Customer Service at (570) 546-9663 for advice.

Save the containers and all packing materials for possible inspection by the carrier or its agent. Otherwise, filing a freight claim can be difficult.

When you are completely satisfied with the condition of your shipment, you should inventory the contents.

Items Needed for Setup

The following items are needed to complete the set up process, but are not included with your machine:

Description	Qty
• Safety Glasses (for each person).....	1 Pair
• Power Lifting Equipment (Rated for at least 1200 lbs.)	1
• Assistant.....	1
• Straightedge 4' (or longer).....	1
• Phillips Head Screwdriver #2	1
• Hex Wrenches 3, 6mm.....	1 Each
• Wrenches/Sockets 10, 13, 17mm	1 Each
• Dust Collection System	1
• 4" Dust Hose (length as needed)	1
• 4" Hose Clamp	2
• Electrician.....	1



Inventory

After all the parts have been removed from shipping crate #1, you should have the following:

Box 1: (Figure 3)	Qty
A. Rip Fence Assembly	1
B. Sliding Table Support Leg Assembly	1
C. Miter Fence	1
D. Miter Gauge.....	1
E. Miter Gauge Base	1
F. Hex Wrench 4mm.....	1
G. Workpiece Hold-Down Assembly.....	1

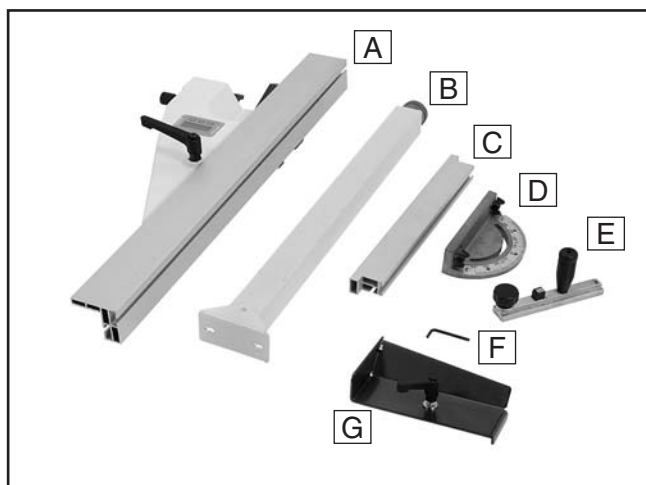


Figure 3. Box 1 contents.

Box 2: (Figure 4)	Qty
H. Cross Cut Fence Assembly.....	1
I. Flip Stop Assembly (on fence)	1
J. Cross Cut Table Assembly	1
K. Cross Cut Fence Extension	1

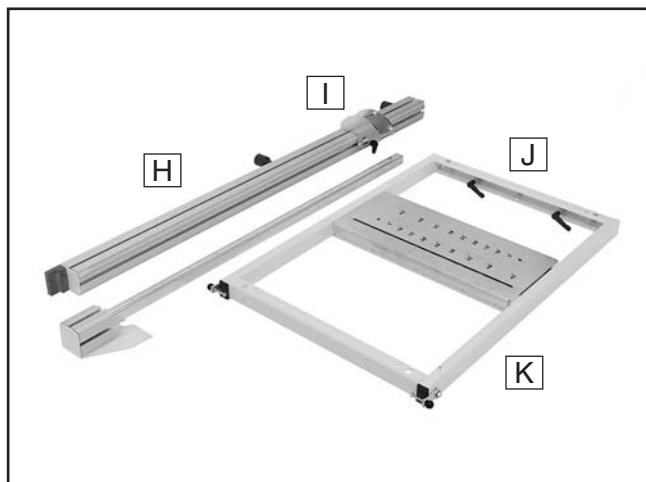


Figure 4. Box 2 contents.

Box 3: (Figure 5)	Qty
L. Blade Guard w/Dust Collection Hose.....	1
M. Hose Support Rod.....	1
N. Hose Support Bracket.....	1
O. Dust Hose Coupler	1
P. Wrenches 19, 30mm	1 Ea.
Q. Hex Wrench 5mm.....	1
R. Hex Key 8mm.....	1
S. Spindle Lock Tool.....	1
T. Push Block	1
U. Push Stick	1
V. Hose Clamps 2½"	2

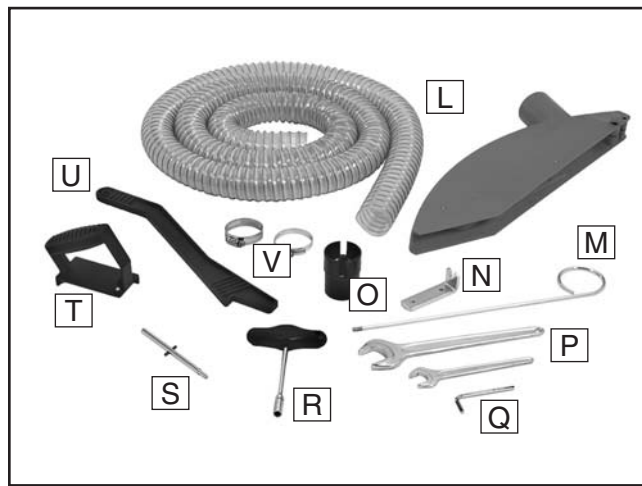


Figure 5. Box 3 contents.

Box 4: (Figure 6)	Qty
W. Small Extension Table.....	1
X. Extension Table Leg.....	1
Y. Extension Table Leg Bracket	1
Z. Knobs M8-1.25 x 22	3

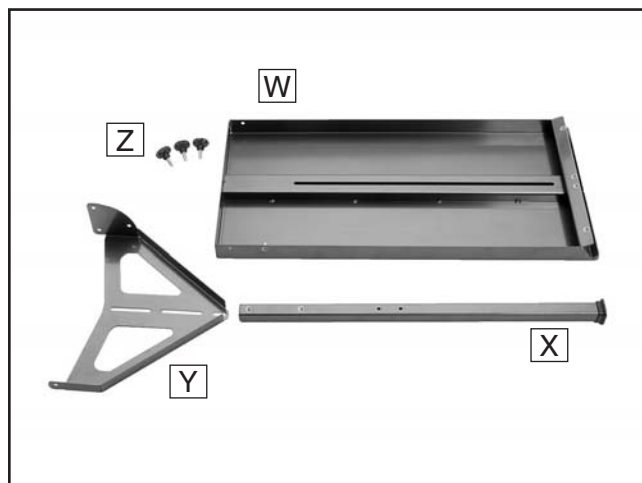


Figure 6. Box 4 contents.



Box 1: (Figure 7)	Qty
AA. Large Extension Table	1
BB. Support Brackets.....	2

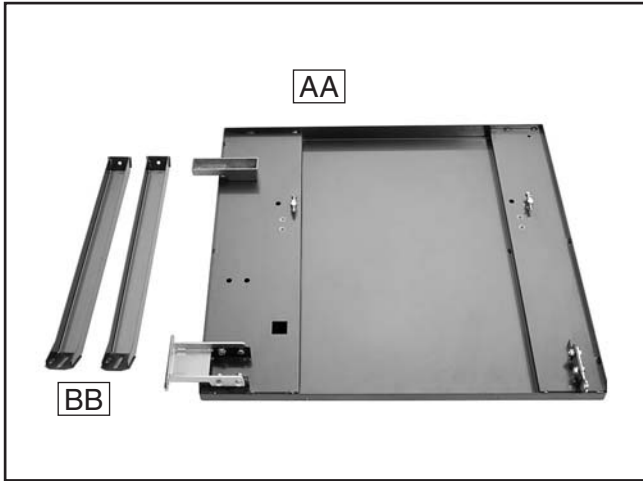


Figure 7. Box 5 contents.

Note: Some of the inventory components are modular and can be used on a variety of machines. As a result of this, you may have received duplicates of some parts. If this is the case, these parts can be saved as spares.

Crate: (Figure 8)	Qty
CC. Machine.....	1
DD. Rip Fence Rail.....	1

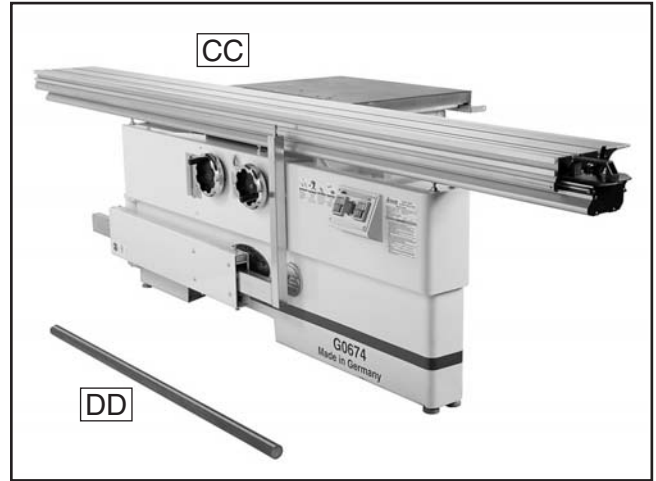


Figure 8. Crate contents.

Hardware: (Not Shown)	Qty
Cap Screws M8-1.25 x 16 (Large Extension Table)	6
Flat Washers 8mm (Large Extension Table, Leg Bracket)	8
Flange Nuts M8-1.25 (Support Brackets)	2
Button Head Cap Screws M8-1.25 x 16 (Extension Table Leg Bracket)	2
Lock Nuts M8-1.25 (Extension Table Leg Bracket)	2
Hex Bolts M10-1.5 x 25 (Support Leg)	2
Flat Washers 10mm (Support Leg)	2
Wing Screw M8-1.25 x 16 (Hose Support Bracket).....	1



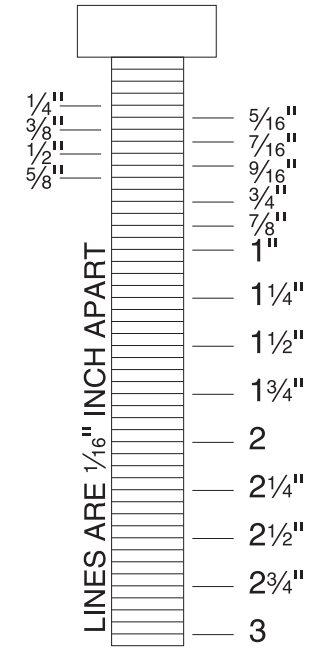
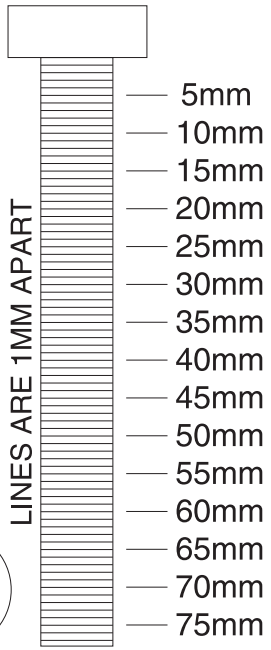
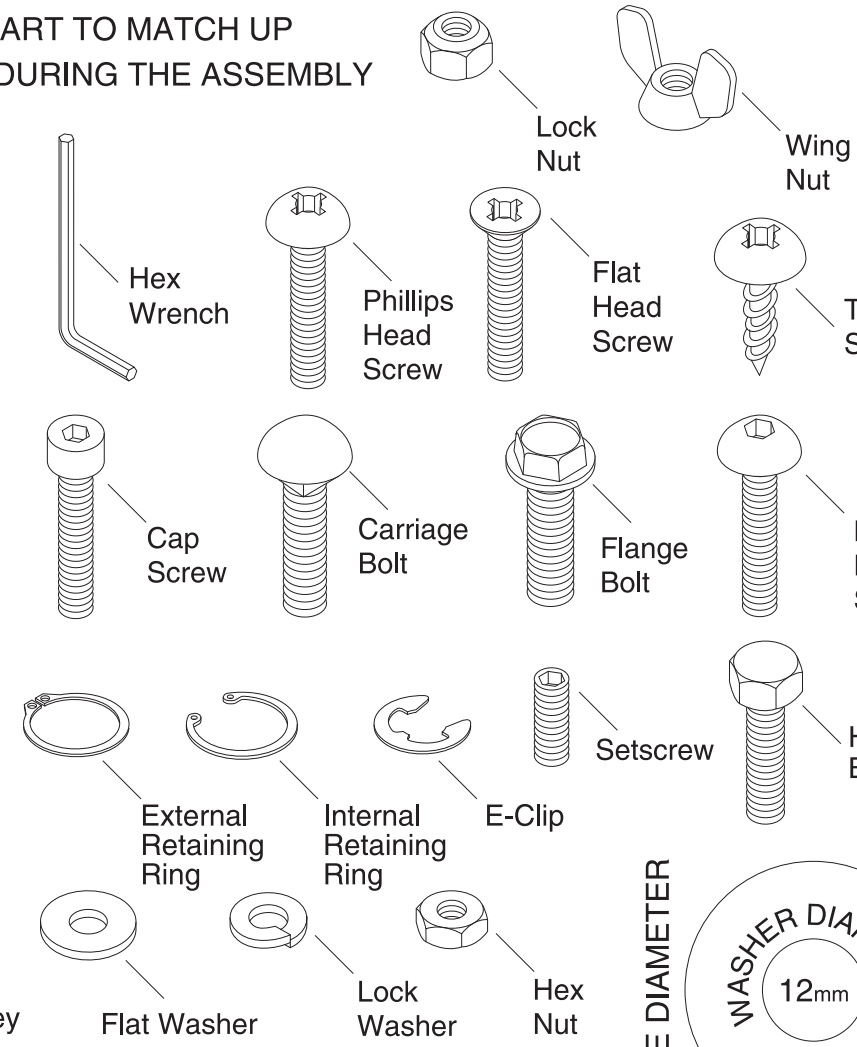
Hardware Recognition Chart

USE THIS CHART TO MATCH UP HARDWARE DURING THE ASSEMBLY PROCESS.

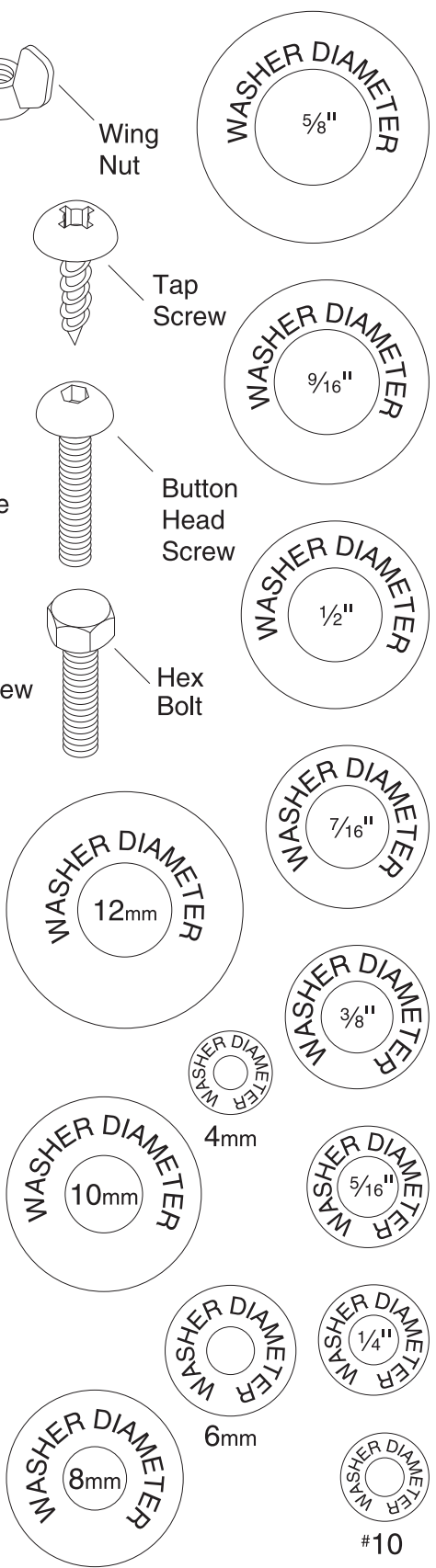
MEASURE BOLT DIAMETER BY PLACING INSIDE CIRCLE

- #10
- 1/4"
- 5/16"
- 3/8"
- 7/16"
- 1/2"

- 4mm
- 6mm
- 8mm
- 10mm
- 12mm
- 16mm




WASHERS ARE MEASURED BY THE INSIDE DIAMETER



Clean Up

The unpainted surfaces are coated with a waxy oil to prevent corrosion during shipment. Remove this protective coating with a solvent cleaner or degreaser, such as shown in **Figure 9**. For thorough cleaning, some parts must be removed. **For optimum performance, clean all moving parts or sliding contact surfaces.** Avoid chlorine-based solvents, such as acetone or brake parts cleaner that may damage painted surfaces. Always follow the manufacturer's instructions when using any type of cleaning product.

	<p>! WARNING Gasoline and petroleum products have low flash points and can explode or cause fire if used to clean machinery. DO NOT use these products to clean the machinery.</p>
---	--

	<p>! CAUTION Many cleaning solvents are toxic if inhaled. Minimize your risk by only using these products in a well ventilated area.</p>
---	---

G2544—Solvent Cleaner & Degreaser
H9692—Orange Power Degreaser
 Great products for removing shipping grease.



Figure 9. Cleaner/degreasers available from Grizzly.

Site Considerations

Floor Load

Refer to the **Machine Data Sheet** for the weight and footprint specifications of your machine. Some floors may require additional reinforcement to support both the machine and operator.

Placement Location

Consider existing and anticipated needs, size of material to be processed through each machine, and space for auxiliary stands, work tables or other machinery when establishing a location for your new machine. See **Figure 10** for the minimum working clearances.

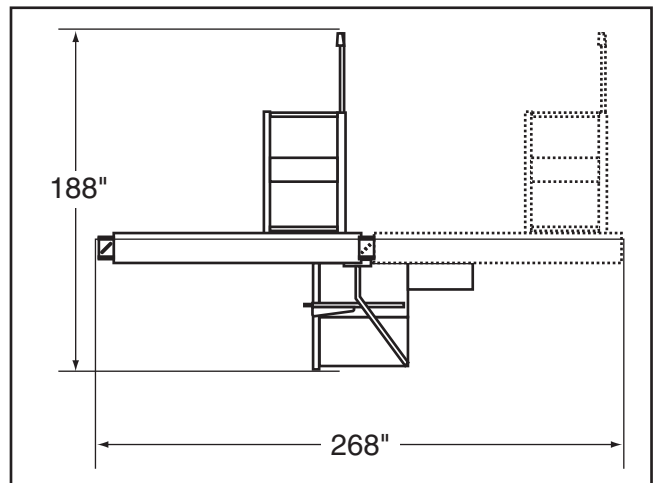
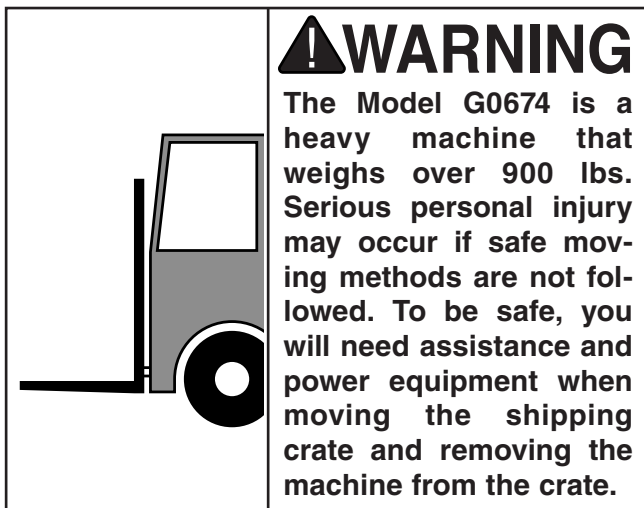


Figure 10. Minimum working clearances.

	<p>! CAUTION Children and visitors may be seriously injured if unsupervised. Lock all entrances to the shop when you are away. DO NOT allow unsupervised children or visitors in your shop at any time!</p>
--	---



Moving & Placing Saw Base Unit



To remove the saw base unit from the crate pallet:

1. Remove the top of the crate and position the forklift forks together and directly beneath the center portion of the saw base unit (**Figure 11**).



Figure 11. Lifting the saw base unit.

!WARNING

DO NOT lift the table saw any higher than necessary to clear the floor. Serious personal injury and damage to the machine may occur if safe moving methods are not followed.

2. With an assistant or two to help stabilize the load, lift the saw base unit just high enough to clear the pallet, and move it to your predetermined location.
3. Lower the saw base unit onto the feet and back the forklift away.

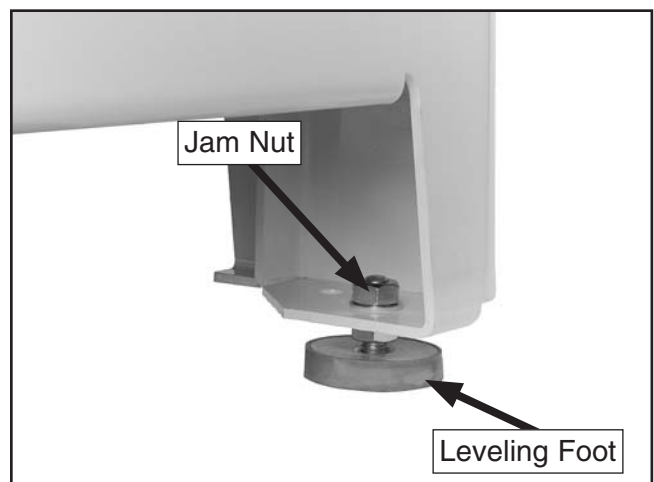


Figure 12. Foot installed in saw base unit leg.

4. Place a level on the saw table and adjust the feet so the saw table is level from left-to-right and from front-to-back. This will allow the table to slide smoothly.
5. Lock the feet in position by tightening the jam nut against the cabinet leg.

Assembly & Setup

Assembly for the Model G0674 consists of attaching the extension tables, the fences, and the cross-cut table.

To assemble and set up the sliding table saw:

1. Remove the M8-1.25 x 16 cap screws and flat washers from the rip fence rail.
2. Place the fence rail over the table brackets, align the holes, then attach the fence rail with the hardware removed in **Step 1** (**Figure 13**).

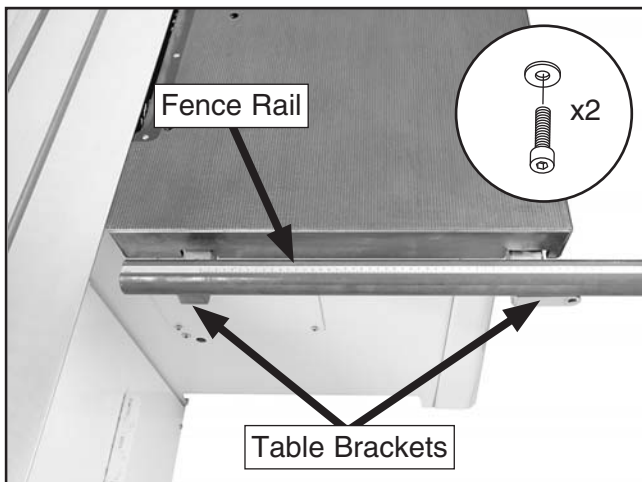


Figure 13. Rip fence rail.

3. Attach the extension table to the main table with shoulder bolts, flat washers, and hex nuts through the brackets at each end. Do not yet fully tighten these fasteners (**Figure 14**).

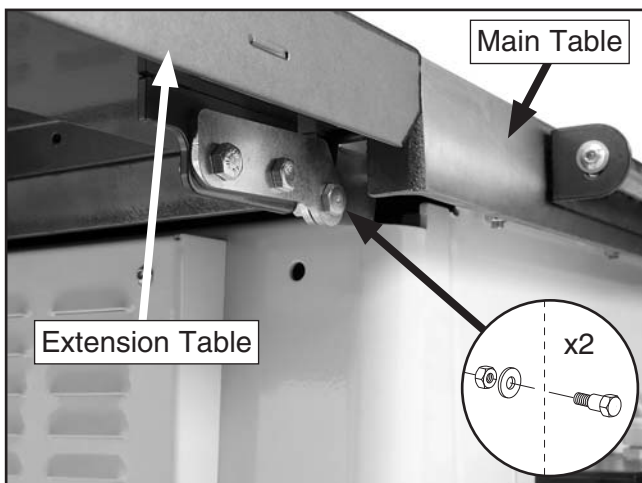


Figure 14. Extension table attached.

4. Swing the table up and attach the rip fence rail bracket to the rip fence rail with one M8-1.25 x 16 cap screw and 8mm flat washer (**Figure 15**).

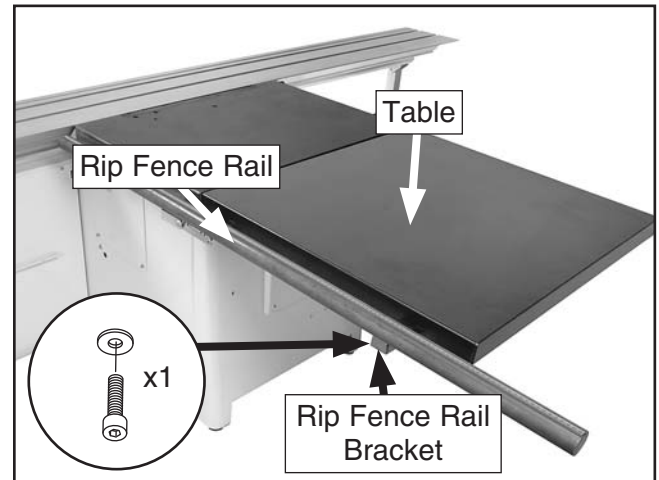


Figure 15. Extension table positioned.

5. Attach the support brackets beneath the extension table with six M8-1.25 x 16 cap screws, six 8mm flat washers, and two M8-1.25 flange nuts. Do not yet fully tighten these fasteners (**Figure 16**).

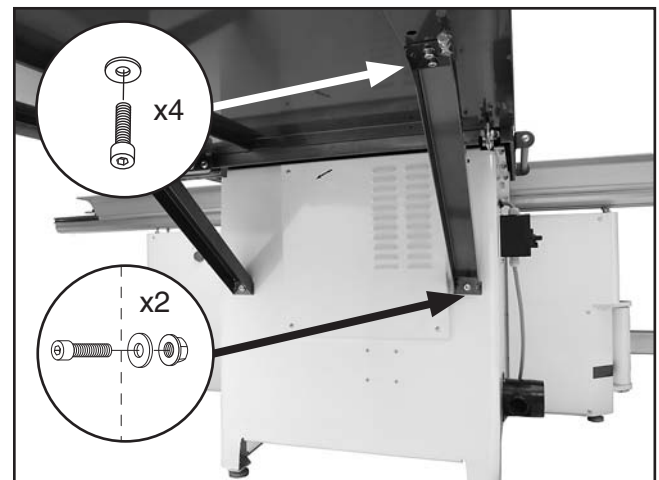


Figure 16. Support brackets.

6. Place a straightedge along the top of the main table and extension table. Have an assistant hold the table so that it is level with the main table while you tighten all of the table hardware.

- Attach the small extension table by loosening the two knobs and placing the end of the table over the table mounting rod (**Figure 17**).

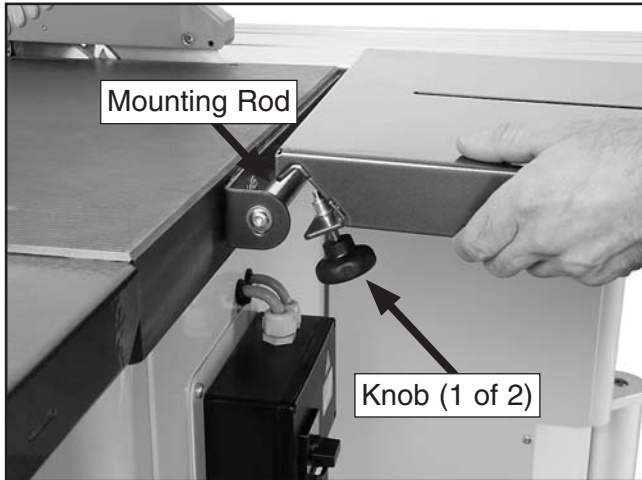


Figure 17. Small extension table.

- Lift the small extension table and attach the leg support with two flange bolts, flat washers, lock nuts and one lock knob. Then connect the extension table leg with the two lock knobs, as shown in **Figure 18**.

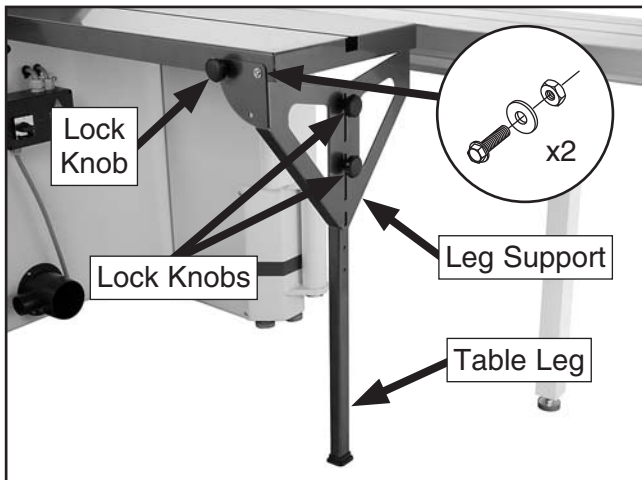


Figure 18. Leg bracket.

- Lay a straightedge across the cast-iron table and the small extension table. Use the two leg knobs to adjust the leg as necessary to create a single, level plane.

- Loosen the lock handles on the crosscut table, then slide the T-slot bar into the sliding table T-slot. Hold the crosscut table horizontal while an assistant places the swinging base cap screw into the center hole on the cross cut table (**Figure 19**).

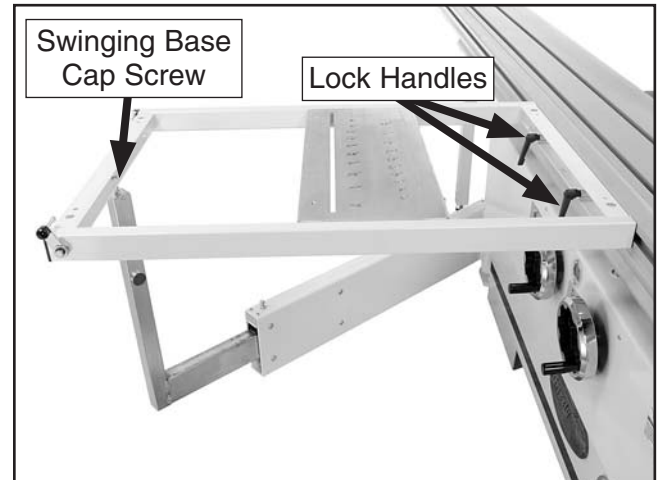


Figure 19. Sliding table mounting.

- Tighten the crosscut table lock handles.
- Lay a straightedge across the crosscut table, sliding table and cast-iron table. Adjust the swinging base cap screw as needed to create a single plane across all three surfaces.
- Attach the support leg to the end of the sliding table base with the two M10-1.5 x 25 hex bolts and two 10mm flat washers (**Figure 20**).

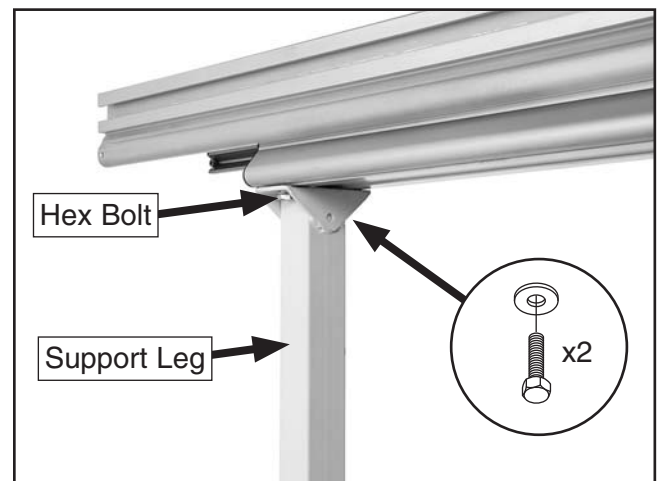


Figure 20. Support leg.

- Adjust the leveling foot at the bottom of the support leg so it touches the ground.

15. Place the rip fence body onto the rip fence rail (Figure 21).

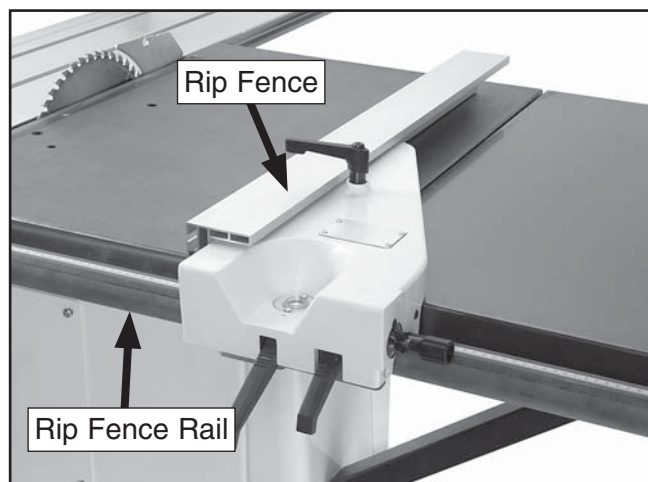


Figure 21. Rip fence assembly.

16. Check if the metal part of the rip fence rests on the surface of the table.

Note: The rip fence body will scratch the table surface if the ride height is not adjusted correctly. Only the slider (Figure 22) should touch the table surface.

—If the rip fence body **does not** rest on the table, then the fence is correctly adjusted.

—If the rip fence body **does** rest on the table, remove the rip fence and turn it upside down. Loosen the hex nut shown in Figure 22 and raise the slider (move it away from the fence body). Tighten the hex nut to lock the ride height and recheck how the rip fence rests on the table.

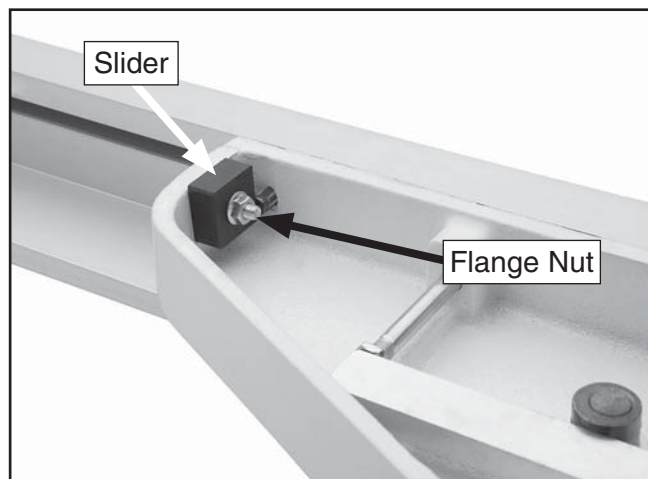


Figure 22. Rip fence height adjustment.

17. Slide the table all the way backward, open the blade guard, then loosen the riving knife center bolt. Slide the riving knife over the bolt as shown in Figure 23, and slightly tighten.

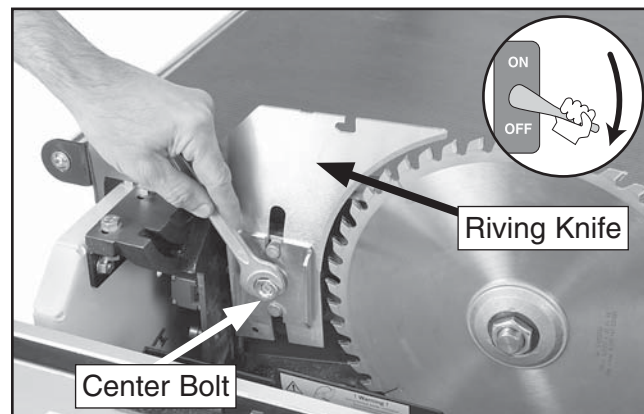


Figure 23. Installing the riving knife.

18. Position the riving knife just below the highest point and about 3mm or 1/8" away from the main blade. **Note:** For a quick gauge, use a 3mm hex wrench to find the correct spacing between the blade and the riving knife, as shown in Figures 24 & 25.

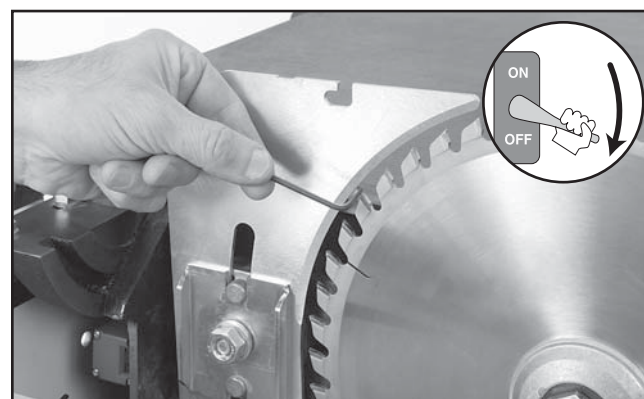


Figure 24. Adjusting the riving knife.

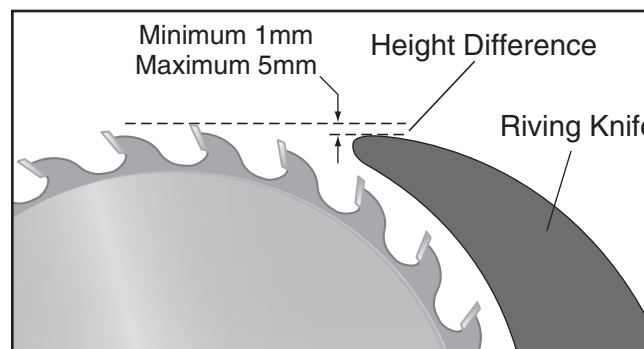


Figure 25. Riving knife vertical alignment.

19. Tighten the center bolt to secure the riving knife in position.

20. Place the arbor locking tool into the arbor hole and rotate the scoring blade by hand until the tool drops into the arbor, locking it. Use the arbor wrench to verify that the scoring blade arbor nut is tight, as shown in **Figure 26**. (The scoring blade arbor nut has right-hand threads and tightens clockwise.)

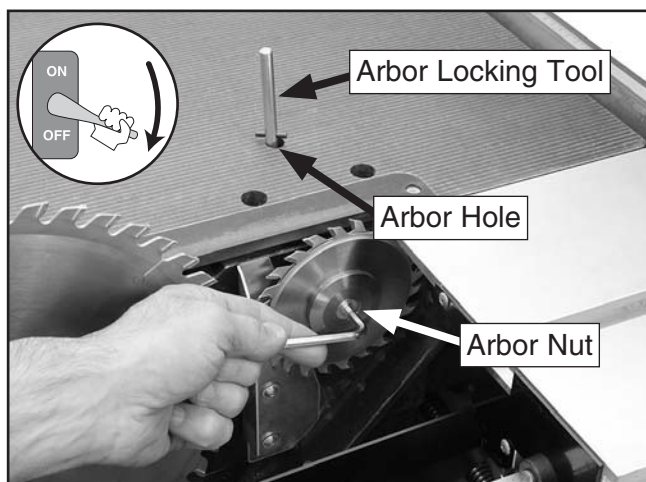


Figure 26. Removing the scoring blade.

21. Move the scoring blade tilt to 0° (blade 90° to table), then raise it up, using the vertical adjustment shown in (**Figure 27**), until it is approximately 1/2" above the table surface.

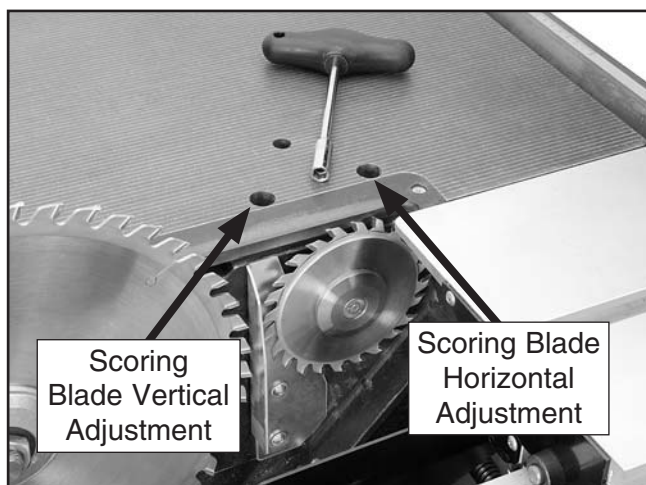


Figure 27. Scoring blade adjustment controls.

22. Position the rip fence against the main blade (or scoring blade) as shown in **Figure 28**.

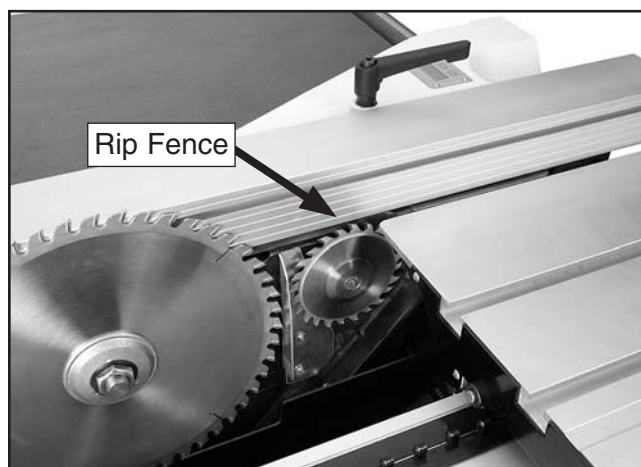


Figure 28. Fence used to align blades.

23. Adjust the scoring blade as necessary, using the horizontal adjustment, until the rip fence evenly touches both blades.

24. Move the rip fence against the blades again. Loosen the screws that secure the rip fence rail, line up the 0" mark on the scale with the viewfinder of the rip fence, then tighten the rip fence rail mounting screws (**Figure 29**).

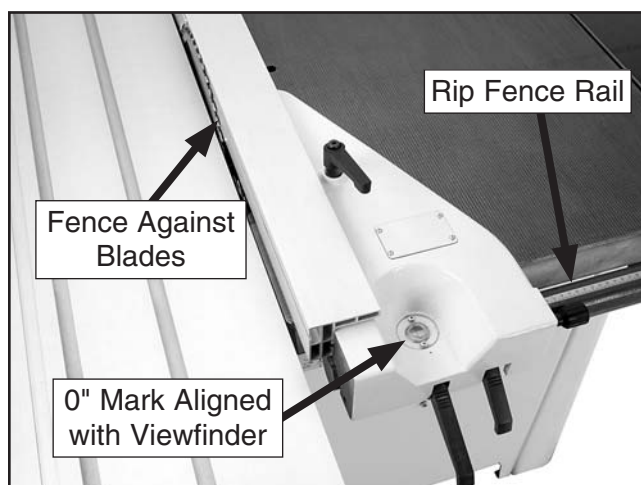


Figure 29. Setting scale to zero.

25. Close the blade guard and move the sliding table back to center.
26. Position the center stud and the T-bolt of the crosscut fence into the placement holes shown in **Figure 30**.

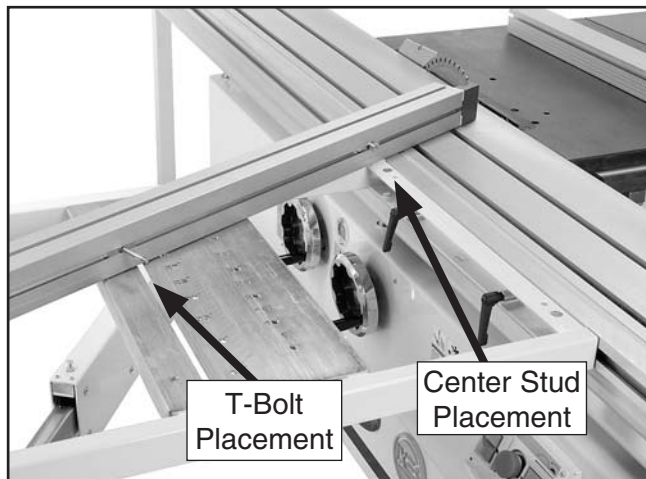


Figure 30. Crosscut fence placement.

27. Thread the M8-1.25 knob with an 8mm flat washer onto the T-bolt to secure the crosscut fence (**Figure 31**).

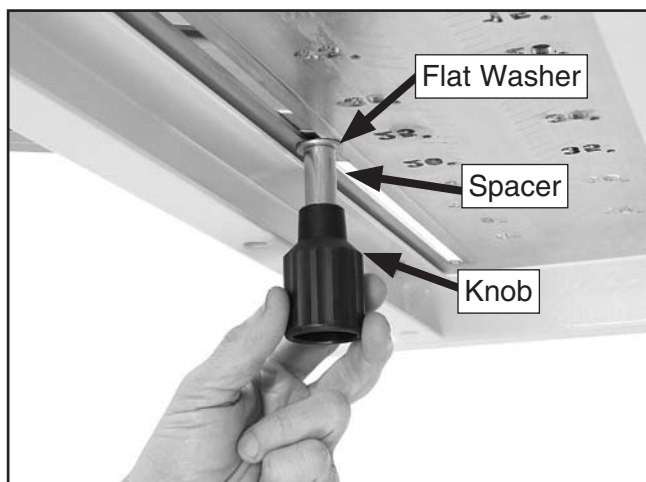


Figure 31. Crosscut fence knob.

28. Connect the dust hose support to the underside of the extension table with the wing screw (**Figure 32**).

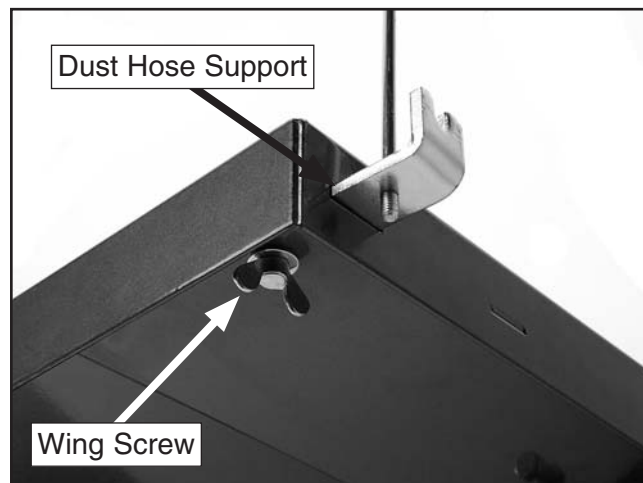


Figure 32. Dust hose support attached.

29. Install the blade guard by sliding it over the riving knife, as shown in **Figure 33**.

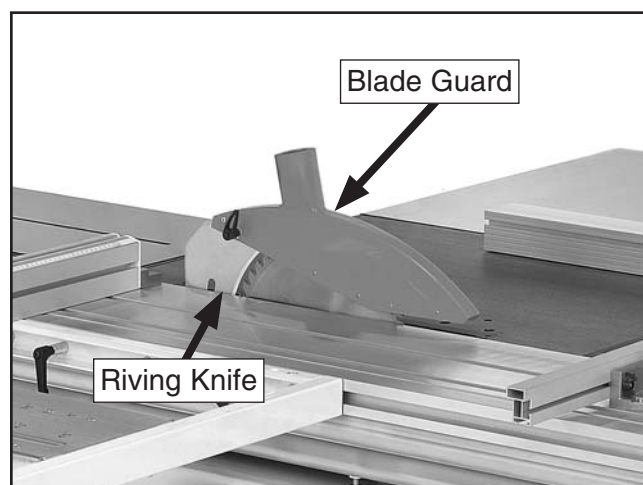


Figure 33. Installing blade guard.

CAUTION

DO NOT operate the Model G0674 without an adequate dust collection system. This saw creates substantial amounts of wood dust while operating. Failure to use a dust collection system can result in short and long-term respiratory illness.

Required CFM at 4" Dust Port: 400 CFM

Do not confuse this CFM recommendation with the rating of the dust collector. To determine the CFM at the dust port, you must consider these variables: (1) CFM rating of the dust collector, (2) hose type and length between the dust collector and the machine, (3) number of branches or wyes, and (4) amount of other open lines throughout the system. Explaining how to calculate these variables is beyond the scope of this manual. Consult an expert or purchase a good dust collection "how-to" book.

- 30.** Attach the included 2½" dust hose to the hose coupler with the 2½" hose clamp, then slide the coupler into the blade guard, as shown in **Figure 34**.

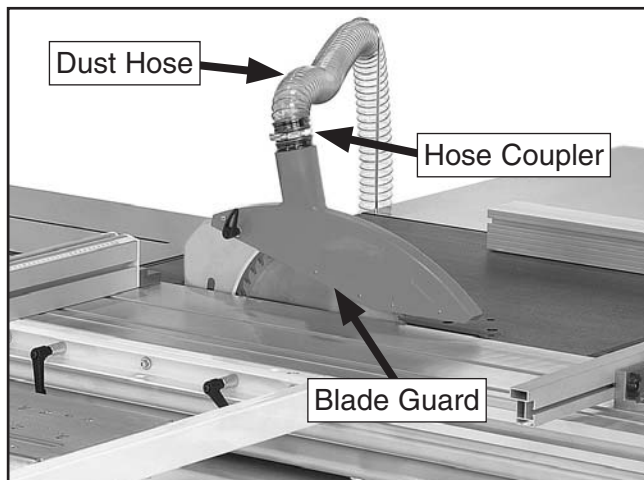


Figure 34. 2½" dust hose connected.

- 31.** Run the 2½" hose over the hose support, as shown in **Figure 35**.

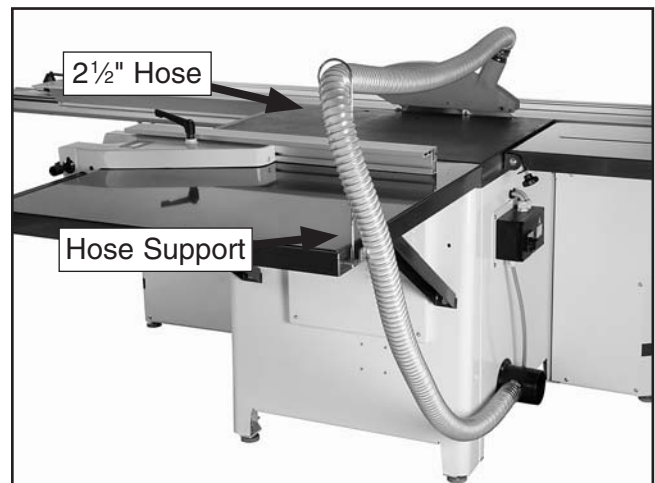


Figure 35. Dust hose support in use.

- 32.** Secure the 2½" and a 4" dust hose to the dust port located under the saw table (**Figure 36**).

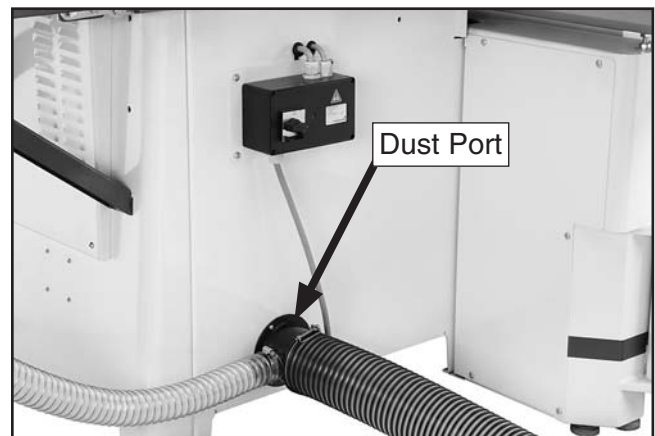


Figure 36. 4" dust port location.

Optional: Run ground wires through the dust hoses and attach the wires to the machine to protect against static electricity.

Test Run

After the machine has been connected to the power source, it **MUST** be test run to make sure all the controls are working properly.

The test run includes verifying that the safety components on the machine work correctly.

Before beginning the test run, review the controls shown in **Figures 37 & 39**.

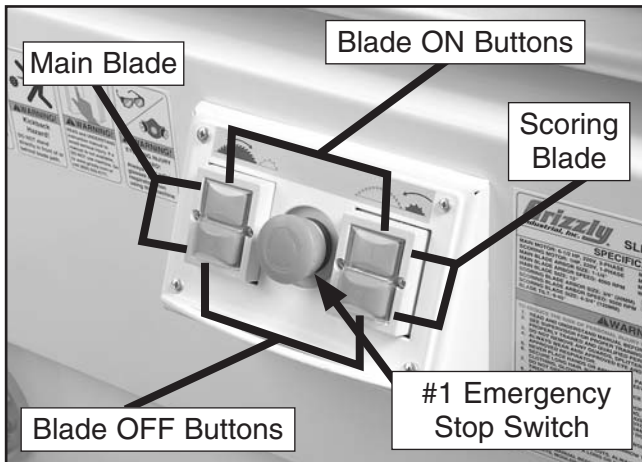


Figure 37. Main power controls.



Figure 38. Emergency stop switch #2.

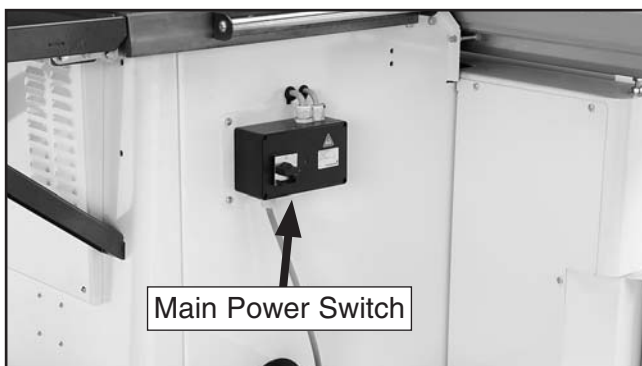


Figure 39. Main power switch location.

!WARNING

If the machine does not operate as stated in this section, review the troubleshooting section on Page 47. If you need additional help, call Tech Support at (570) 546-9663. **DO NOT** place a machine into regular operation if you suspect that it is malfunctioning or serious injury could occur.

To test run the saw:

1. Read and understand this entire manual before performing the test run.
 2. Put on safety glasses, make sure any bystanders are out of the way, and that all tools have been removed from the saw.
 3. Connect the machine to power.
 4. Turn on the main power switch, located on the side of the saw base unit.
 5. Push in, then rotate both emergency stop switches clockwise until they pop out. This resets the emergency stop switches so the machine can operate.
 6. Press the main blade ON button, then the scoring blade ON button. The blades should start up and run smoothly without any problems.
- If any problems occur, press the nearest emergency stop switch.

Continued on next page →

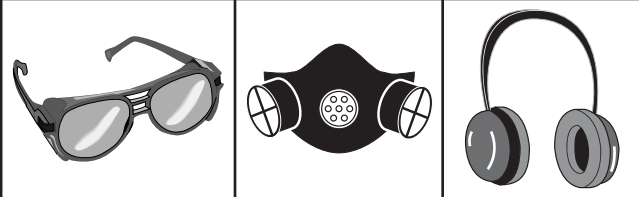
7. One at a time, press the scoring blade, then main blade OFF buttons. The blades should stop running. As the main blade comes to a stop, watch the direction that it is spinning.
 - If the main blade is rotating counterclockwise, disconnect the saw from power and exchange wires R & T in the power connection box. See **Wiring**, starting on **Page 56**.
8. Depress the #1 emergency stop switch.
9. Press the blade ON buttons. Nothing should happen.
 - If the stop switch is working correctly, reset the switch.
 - If the machine does start (with the stop button pushed in), immediately disconnect power to the machine. The #1 emergency stop switch safety feature is not working correctly. This safety feature must work properly before proceeding with regular operations. Call Tech Support for help.
10. Repeat **Steps 6–7** with the #2 emergency stop switch.
11. Make sure both emergency stop buttons are reset before continuing.
12. Turn the main power switch **OFF** and DISCONNECT SAW FROM POWER!
13. Move the sliding table all the way forward, then open the blade guard. This opens the blade guard limit switch.
14. Connect the saw to the power source and turn the main power switch key ON.
15. (During this step, be prepared to immediately press the #1 emergency stop switch if the blades start operating.) Press the blade ON buttons. Nothing should happen.
16. Turn the main power switch **OFF** and DISCONNECT SAW FROM POWER!
17. Close the blade guard and move the sliding table back to the center of the machine.



SECTION 4: OPERATIONS

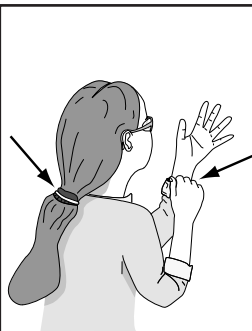
! WARNING

Damage to your eyes, lungs, and hearing could result from using this machine without proper protective gear. Always wear safety glasses, a respirator, and hearing protection when operating this machine.



! WARNING

Loose hair and clothing could get caught in machinery and cause serious personal injury. Keep loose clothing and long hair away from moving machinery.



NOTICE

If you have never used this type of machine or equipment before, WE STRONGLY RECOMMEND that you read books, trade magazines, or get formal training before beginning any projects. Regardless of the content in this section, Grizzly Industrial will not be held liable for accidents caused by lack of training.

Basic Controls

Use the descriptions and **Figures 40–27** below to familiarize yourself with the basic controls of the G0674.

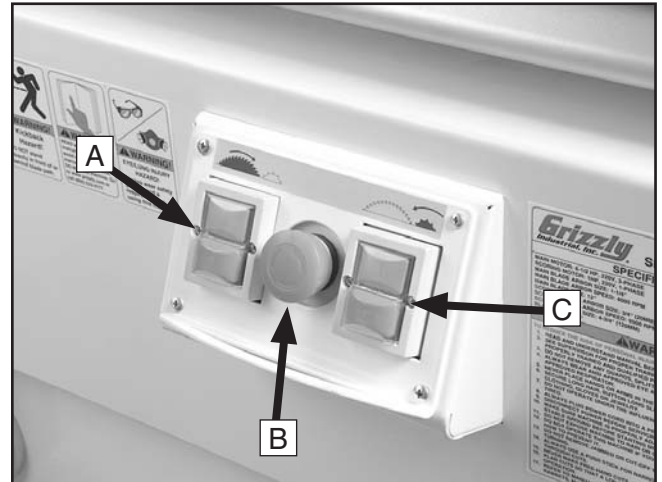


Figure 40. Control panel close-up.

- A. **Main Blade ON/OFF Buttons**—Start and Stop the main saw blade.
- B. **#1 EMERGENCY STOP Button**—Disconnects power to all motors in the motor cabinet.
- C. **Scoring Blade ON/OFF Buttons**—Start and stop the scoring blade.

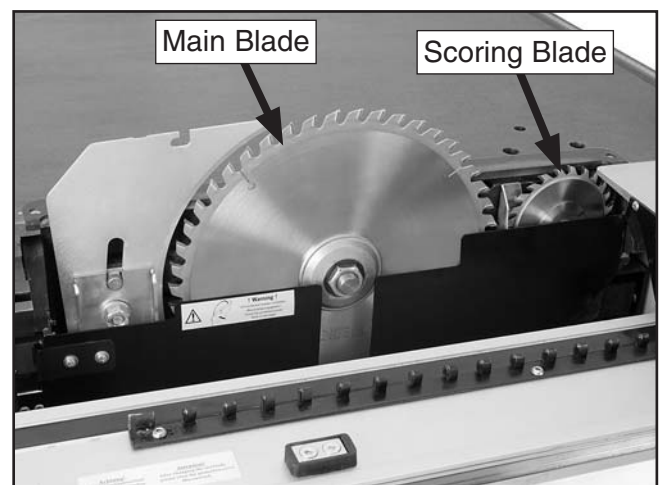


Figure 41. Blades.

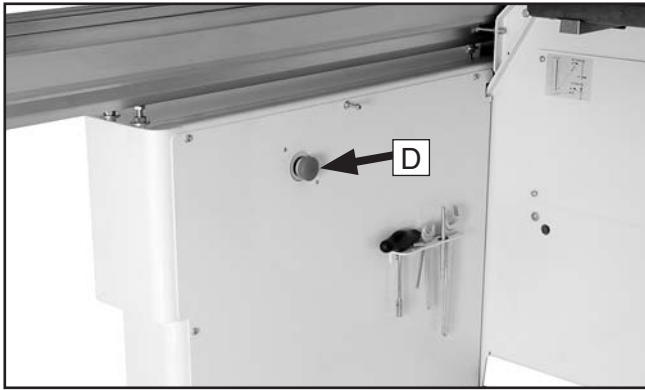


Figure 42. #2 Emergency stop button.

- D. #2 EMERGENCY STOP Button**— Disconnects power to both motors in the motor cabinet.

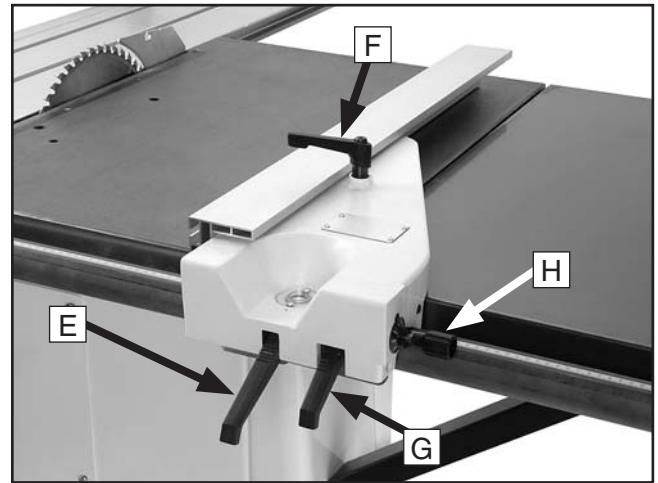


Figure 43. Fence controls.

- E. Fence Assembly Lock Down Lever**— Secures the fence assembly into position along the fence rail.
- F. Forward/Backward Slide Lock Handle**— Secures the aluminum fence piece on its forward/backward slide track.
- G. Micro-Adjust Lock Lever**—Secures the micro-adjust clamp to allow precise adjustments with the micro-adjust knob.
- H. Micro-Adjust Knob**—Precisely adjusts the fence.

Safety Tips

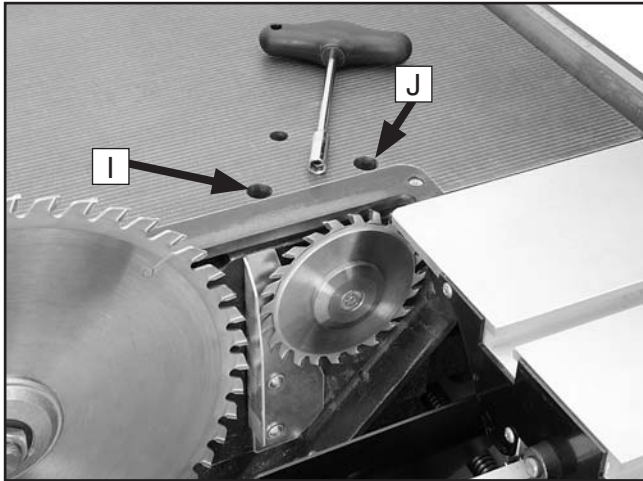


Figure 44. Scoring blade adjustment knobs.

- I. **Scoring Blade Elevation Bolt**—Adjusts the height of the scoring blade.
- J. **Scoring Blade Alignment Bolt**—Adjusts the horizontal position of the scoring blade.

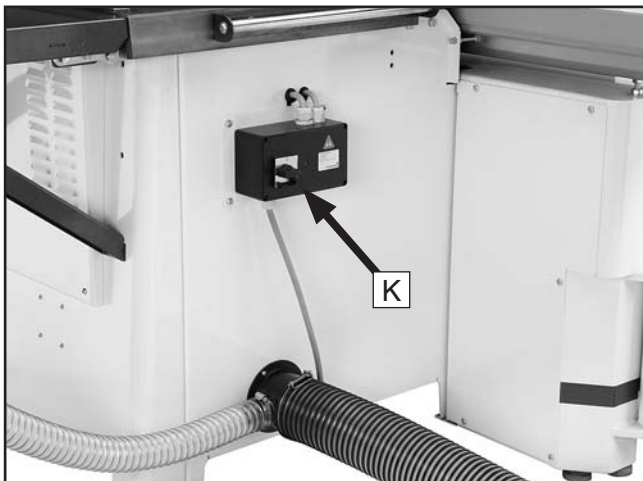


Figure 45. Main power switch.

- K. **Main Power Switch**—Controls the flow of power to the machine.

Your safety is important. The tips below are intended to supplement **SECTION 1: SAFETY**. But remember, no safety list can cover every situation. The operator is ultimately responsible for their own safety, as well as the safety of bystanders. Every cutting operation is uniquely different and may require safety equipment or safety procedures not mentioned in this manual.

Please follow these safety tips EVERY time you use your saw:

- Stand to the left of the blade line-of-cut when performing a cutting operation with the sliding table.
- Turn **OFF** the saw and allow the blade to come to a complete stop before removing the cut-off piece.
- Make sure that the riving knife is always aligned with the main blade before cutting!
- Always position the blade guard to the correct height above the workpiece.
- Carefully plan each cutting operation to avoid injuries.
- When you release the sliding table lock, make sure that the knob is positioned so that it will not lock the table during a cut.



Blade Selection

Ripping blade features:

- Best for cutting with the grain of the workpiece.
- 20-40 teeth.
- Flat-top ground tooth profile.
- Large gullets for large chip removal.

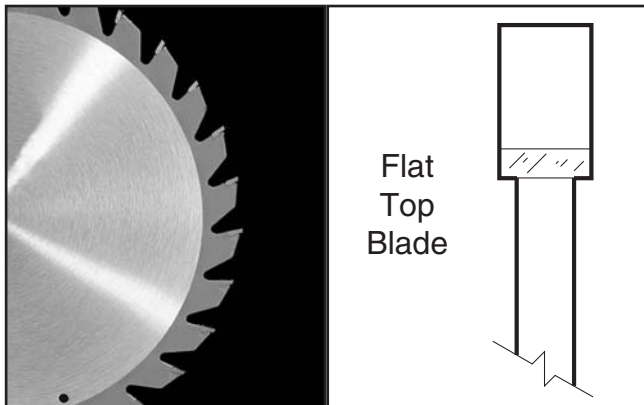


Figure 46. Ripping blade.

Crosscut blade features:

- Best for cutting across the grain of the workpiece.
- 60-80 teeth.
- Alternate top bevel tooth profile.
- Small hook angle and a shallow gullet.



Figure 47. Crosscutting blade.

Combination blade features:

- Adequate for cutting both with and across the grain.
- 40-50 teeth.
- Alternate top bevel and flat, or alternate top bevel and raker tooth profile.
- Teeth are arranged in groups of five.
- Gullets are small and shallow within the groups of five teeth, similar to a cross-cut blade; then large and deep between each group of five, like a ripping blade.

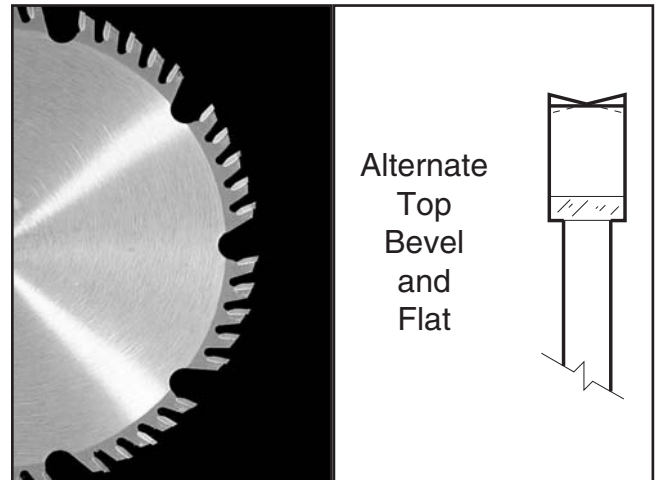


Figure 48. Combination blade.

Laminate blade features:

- Best for cutting plywood or veneer.
- 40-80 teeth.
- Triple chip tooth profile.
- Very shallow gullet.

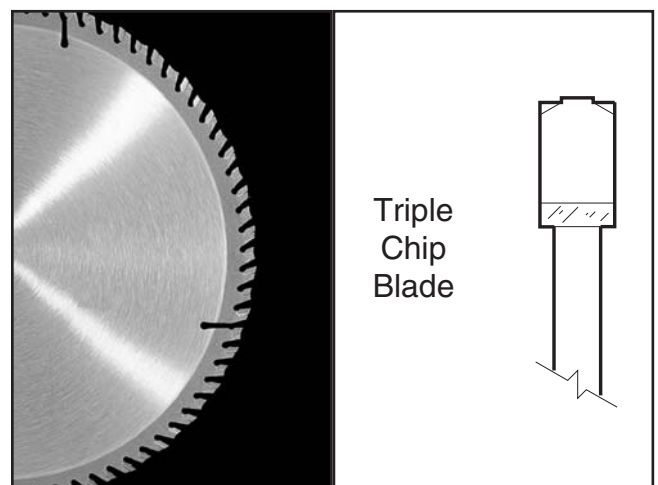


Figure 49. Laminate blade.

Changing Main Blade

The Model G0674 performs best when using high quality, sharp blades. Whenever the main blade starts to get dull, sharpen or replace it with a new blade.

To change the main blade:

1. DISCONNECT SAW FROM POWER!
2. Move the blade tilt to 0° (blade 90° to table) and raise the main blade as far as it will go.
3. Move the sliding table all the way backward to expose the internal blade guard that covers the blades and riving knife, as shown in **Figure 50**.



Figure 50. Internal blade guard exposed.

4. Pull the blade guard away from the blades to expose the mounting assembly. (The internal blade guard is held in place by two metal clips.)
5. Place the arbor locking tool into the arbor lock hole and carefully rotate the blade until the lock tool drops into the hole in the arbor. This will prevent the blade from turning during the next step.

6. Use the arbor wrench to remove the arbor nut and arbor flange, then pull the old blade off the arbor.

Note: *The arbor nut has left hand threads and loosens by turning clockwise.*

7. Slide the new blade over the arbor with the teeth facing the right of the saw, as shown in **Figure 51**.

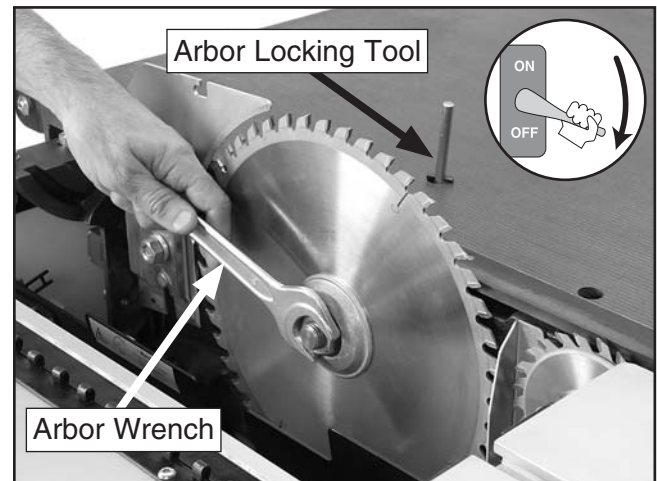


Figure 51. Replacing the main blade.

8. Re-install the arbor flange and the arbor nut, then tighten them against the blade as shown in **Figure 51**.
9. Move the blade guard back until it snaps into its original position, next to the blades, then center the sliding table.

Blade Guard Assembly

The "blade guard" (**Figure 52**) is mounted to the riving knife and is designed to lift as the workpiece is pushed into the blade and remain in contact with the workpiece throughout the entire cut.

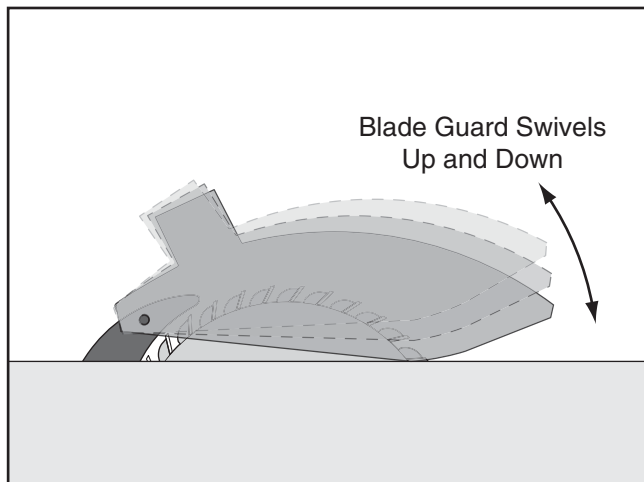


Figure 52. Blade guard illustration.

The guard reduces injury risk by providing a barrier around the blade that prevents accidental contact and contains flying wood chips.

To ensure that the guard does its job effectively, the guard must always be in the downward position while cutting, and the hinge mechanism must be maintained in good working condition so the guard can freely pivot up and down.

When to Use the Blade Guard

The blade guard assembly **MUST** always be installed on the saw for all normal through cuts (those where the blade cuts all the way through the thickness of the workpiece).

When Not to Use the Blade Guard

The blade guard cannot be used on any non-through cuts (those in which the blade does not cut all the way through the thickness of the workpiece).

Sometimes the blade guard or its components can get in the way when cutting very narrow workpieces or other specialized cuts. Because the blade guard is provided to decrease your risk of injury, it should not be used if it gets in the way of making a safe cut. Use good judgement!

NOTICE

Any time the blade guard cannot be used, the riving knife must remain installed.



Riving Knife

The riving knife (**Figure 53**) works in the same manner as the blade splitter on the blade guard assembly. It is a metal plate that prevents the newly cut workpiece from pinching the backside of the blade and causing kickback.

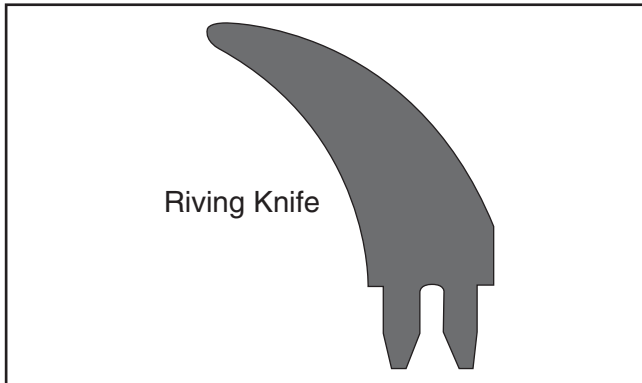


Figure 53. Illustration of a typical riving knife.

The key difference between a blade splitter and the riving knife is that the riving knife mounts below the blade's highest point of rotation, as shown in **Figure 54**.

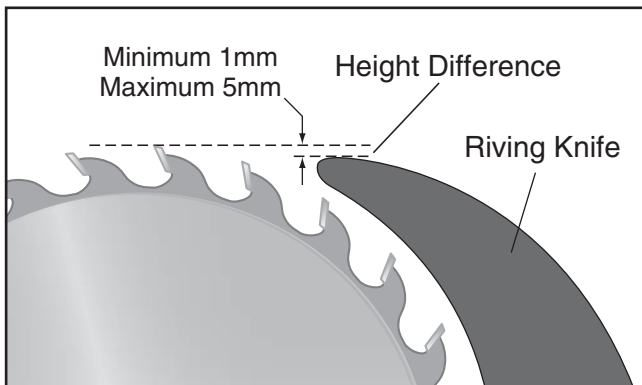


Figure 54. Height difference between riving knife and blade.

The height difference between the riving knife and the blade allows the workpiece to pass over the blade during non-through cuts (those in which the blade does not cut all the way through the thickness of the workpiece).

The riving knife also acts as a barrier behind the blade to reduce the risk of hands being pulled into the blade if a kickback occurs.

!WARNING

In order to work properly, the riving knife cannot be bent or misaligned with the blade. If the riving knife gets accidentally bent, take the time to straighten it or just replace it. Using a bent or misaligned riving knife will increase the risk of kickback!

NOTICE

Some thin-kerf blades may be thinner than the thickness of the riving knife. **DO NOT** install these blades on the saw, because the workpiece will hit the riving knife during operation, possibly causing kickback. Always make sure the kerf of a blade you install is not thinner than the riving knife.

When to Use the Riving Knife

Use the riving knife for all non-through cuts made with a standard table saw blade (i.e., dados or rabbet cuts in which a dado blade is NOT used, and when using a tenoning jig).

Also, use the riving knife for those special operations where the blade guard or its components get in the way of safe operation, such as with very narrow cuts.

When Not to Use the Riving Knife

The riving knife CANNOT be used with a dado blade. Otherwise, the riving knife height will exceed the blade height and the workpiece will hit the riving knife during the cut, forcing the operator into a dangerous situation of trying to turn the saw off with the workpiece stuck halfway through the cut.

In addition, although it is possible to use the riving knife for through cutting operations, the blade guard assembly offers far more injury protection and risk reduction than the riving knife. Therefore, **we strongly recommend** that you use the blade guard assembly instead of the riving knife for these types of cuts.

Riving Knife Adjustment

The ideal riving knife adjustment places the riving knife just below the highest point and approximately 3mm away from the main blade.

To adjust the riving knife:

1. DISCONNECT SAW FROM POWER!
2. Move the blade tilt to 0° (blade 90° to table), and raise the main blade as far as it will go.
3. Move the sliding table all the way forward to expose the internal blade guard that covers the blades and riving knife.
4. Pull the blade guard away from the riving knife to expose the mounting assembly. (The internal blade guard is held in place with two metal clips.)
5. Loosen the riving knife center bolt as shown in **Figure 55**.



Figure 55. Re-adjusting the riving knife.

6. Position the riving knife about 3mm or 1/8" away from the nearest tooth on the main blade and slightly below the highest tooth on the blade (see **Figure 54**).

Note: For a quick gauge, use a 3mm hex wrench to find the correct spacing between the blade and the riving knife, as shown in **Figure 56**.

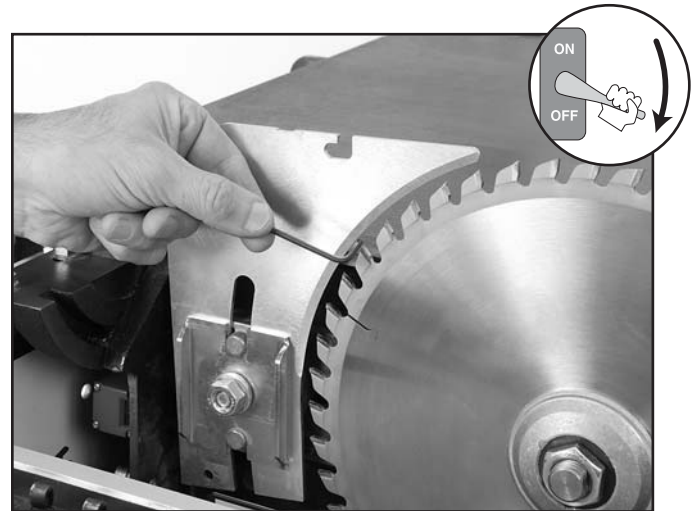


Figure 56. Aligning the riving knife.

7. Tighten the center bolt to secure the riving knife in position.
8. Move the blade guard back until it snaps into its original position, and move the sliding table back to center.

Workpiece Inspection

Some workpieces are not safe to cut or may require modification before they are safe to cut. **Before cutting, inspect all workpieces for the following:**

- **Material Type:** This machine is intended for cutting natural and man-made wood products, laminate covered wood products, and some plastics. Cutting drywall or cementitious backer board creates extremely fine dust and may reduce the life of the bearings. This machine is NOT designed to cut metal, glass, stone, tile, etc.; cutting these materials with a table saw may lead to injury.
- **Foreign Objects:** Nails, staples, dirt, rocks and other foreign objects are often embedded in wood. While cutting, these objects can become dislodged and hit the operator, cause kickback, or break the blade, which might then fly apart. Always visually inspect your workpiece for these items. If they can't be removed, DO NOT cut the workpiece.
- **Large/Loose Knots:** Loose knots can become dislodged during the cutting operation. Large knots can cause kickback and machine damage. Choose workpieces that do not have large/loose knots or plan ahead to avoid cutting through them.
- **Wet or "Green" Stock:** Cutting wood with a moisture content over 20% causes unnecessary wear on the blades, increases the risk of kickback, and yields poor results.
- **Excessive Warping:** Workpieces with excessive cupping, bowing, or twisting are dangerous to cut because they are unstable and often unpredictable when being cut. DO NOT use workpieces with these characteristics!
- **Minor Warping:** Workpieces with slight cupping can be safely supported if the cupped side is facing the table or the fence. On the contrary, a workpiece supported on the bowed side will rock during a cut and could cause kickback or severe injury.

Non-Through & Through Cuts

Non-Through Cuts

A non-through cut is a sawing operation where the blade does not protrude above the top face of the wood stock, as shown in **Figure 57**.

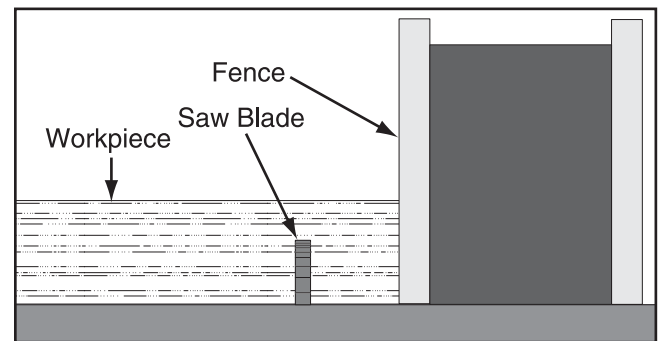


Figure 57. Example of a non-through cut.

Through Cuts

A through cut is a sawing operation in which the workpiece is completely sawn through, as shown in **Figure 58**. Examples of through cuts are rip cuts, cross cuts, miter cuts, and beveled cuts. The blade guard assembly **MUST** be used when performing through cuts.

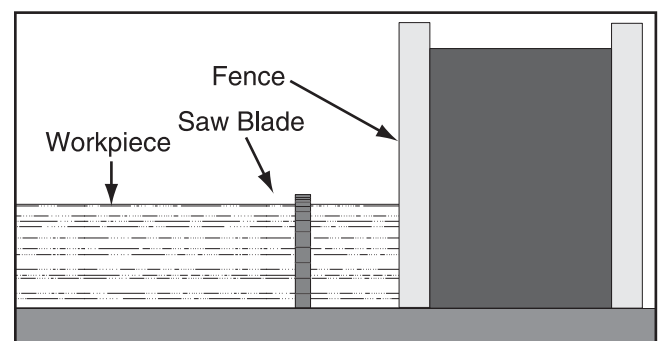


Figure 58. Example of a through cut (blade guard not shown for illustrative clarity).

Adjusting and Replacing Scoring Blade

The scoring blade included with the sliding table saw consists of an inner and outer blade with internal shims. The shims are provided so the scoring blade set can match the kerf thickness of the main blade. **Figure 59** shows the scoring blade set laid out for identification. For optimum performance, replace the scoring blades when they start to get dull.



Figure 59. Scoring blade set.

To change the scoring blade:

1. DISCONNECT SAW FROM POWER!
2. Move the blade tilt to 0° (blade 90° to table), and raise the scoring blade all the way up.
3. Move the sliding table all the way backward to expose the internal blade guard that covers the blades and riving knife.
4. Pull the blade guard away from the riving knife to expose the mounting assembly. (The internal blade guard is held in place with two clips.)
5. To remove the scoring blade, insert the arbor locking tool to keep the arbor from turning and use the arbor wrench to remove the arbor nut and arbor flange (see **Figure 60**). **Note:** The arbor nut has right-hand threads and loosens by turning counterclockwise.
6. Adjust the width of the scoring blade to equal the kerf thickness of the main blade by adjusting the number of shims between the blades.
7. Install the new or adjusted scoring blade set, re-install the arbor flange and the arbor nut, and tighten them against the blade set.
8. Move the blade guard back until it snaps into its original position, next to the blades, and center the sliding table.
9. Move the rip fence against the main blade (or scoring blade).
10. Adjust the scoring blade, using the scoring blade alignment bolt, until the rip fence touches both blades.
11. Adjust the scoring blade elevation bolt until the scoring blade is just above the level of the table.
12. Perform a test cut and check for chip out on the underside of the test piece. If there is chip out, re-adjust the scoring blade to equal the thickness of the main blade.

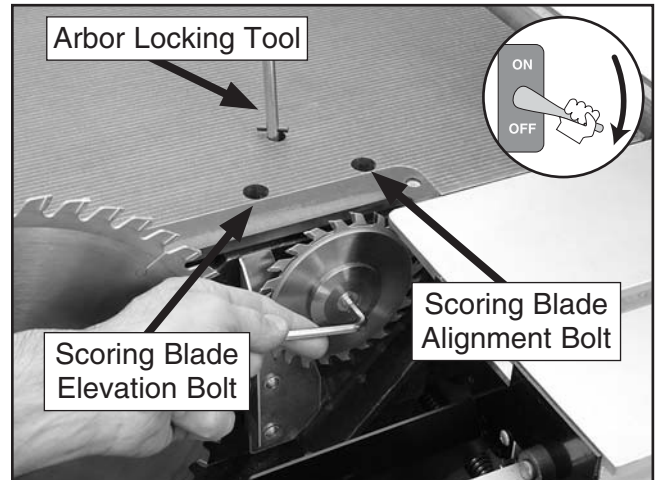


Figure 60. Removing the scoring blade.

Rip Cutting

The Model G0674 has the capability of rip cutting full size panels (**Figure 61**). The sliding table removes the burden of sliding a large and heavy panel over a stationary table surface.



Figure 61. Rip cutting with the sliding table.

This saw also has the capability of rip cutting smaller boards with the rip fence, using the machine as a traditional table saw (**Figure 62**). Smaller, lighter boards are easier to slide across the stationary cast iron table surface to the right of the saw blade.



Figure 62. Traditional rip cutting.

Determine which cutting operation will be best suited for the workpiece to be ripped.

—To use the sliding table, go to **Rip Cutting with Sliding Table**.

—To use the rip fence, go to **Rip Cutting w/ Rip Fence**.

Rip Cutting with Sliding Table

1. Drop the crosscut fence into the forward stud hole and rotate it until it touches the 90° stop bolt (**Figure 63**).

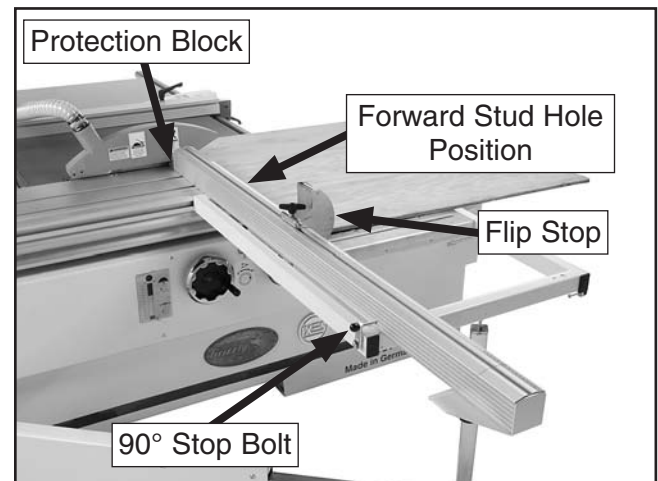


Figure 63. Crosscut fence mounting locations.

2. Check to make sure the fence is at 90° and adjust it as described in **Squaring Crosscut Fence to Blade** on **Page 55** if necessary.
3. Slide the protection block next to the blade teeth to calibrate the scale, then tighten the lock knob.

Note: *The scale will not be accurate if the protection block is cut.*

4. Set the flip stop to the desired width-of-cut.
5. Position the blade guard to the correct height for your workpiece.
6. Load the workpiece onto the table saw. The set up should look similar to **Figure 61**.
7. Take all the necessary safety precautions, then perform the cutting operation.

Rip Cutting with Rip Fence

1. Slide the crosscut table out of the way.
2. Lock the sliding table into a stationary position (see **Figure 64**).



Figure 64. Sliding table lock.

3. Place the rip fence in the vertical position for larger workpieces, or in the horizontal position for angled cuts when the blade would otherwise contact the fence and for thin workpieces (see **Figure 65**).

Note: *Placing the rip fence in the horizontal position will affect the accuracy of the scale. Make sure to compensate for the additional width of the fence when it is in this position.*

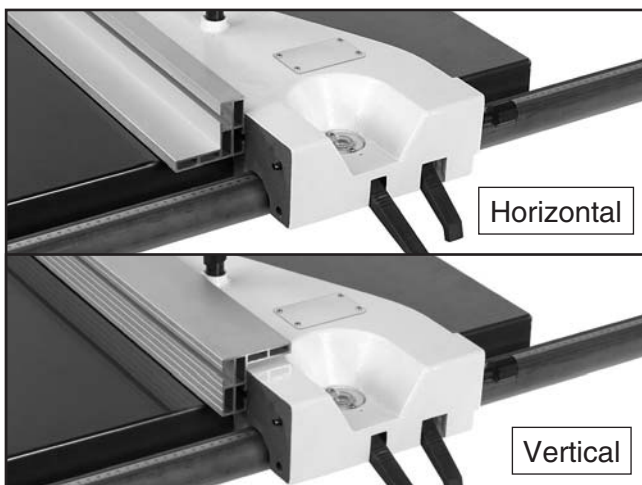


Figure 65. Rip fence positions.

4. Slide the leading end of the rip fence so it is even with the center of the main saw blade as shown in **Figure 66**. Do not slide the rip fence farther than this or binding may occur, causing kickback.

Note: *This technique allows the finished cut-off piece to “fall” away from the blade when the cutting operation is complete, reducing the possibility of kickback.*

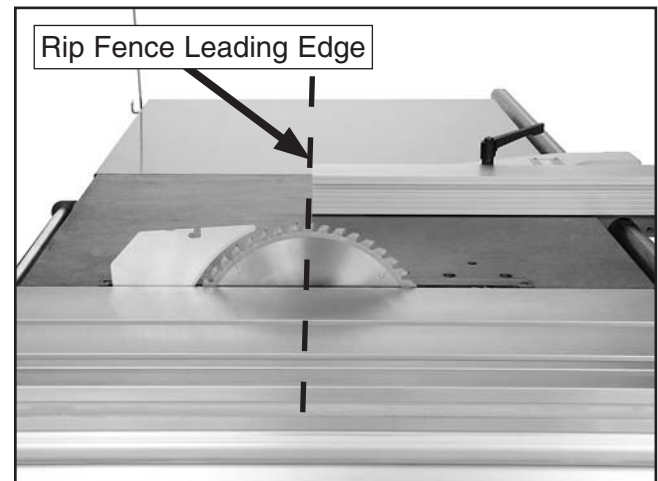


Figure 66. Rip fence even with center of blade (blade guard removed for clarity).

5. Lift the lock lever and position the rip fence to approximately the desired width-of-cut.
6. Push down the micro-adjust lock lever (**Figure 67**) and turn the micro-adjust knob to zero in on the desired width-of-cut.

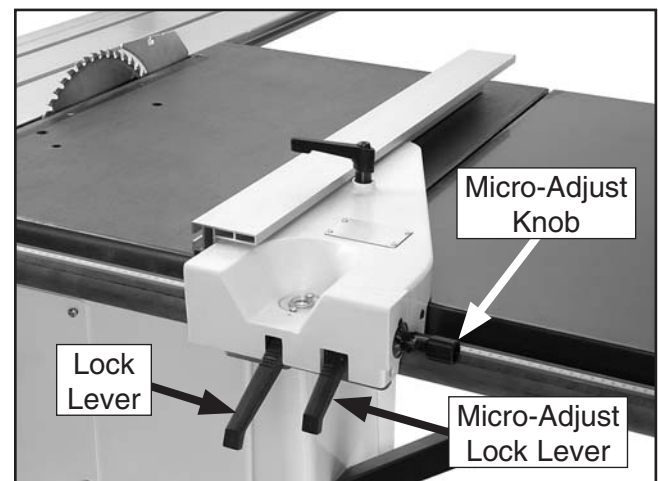


Figure 67. Rip fence micro-adjusting controls.

7. Push down the lock lever, then perform the cutting operation.

Crosscutting

"Crosscutting" means cutting across the grain of a natural wood workpiece. In other man-made materials, such as MDF or plywood, crosscutting means cutting across the width of the workpiece.

The Model G0674 can crosscut full size panels with the crosscut fence in the forward or rear position. It is generally easier to load full size panels with the crosscut fence mounted in the forward position (see **Figure 68**).

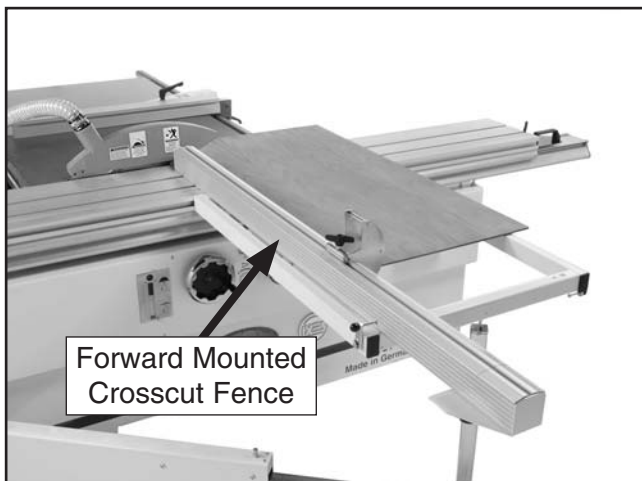


Figure 68. Crosscutting full size panel.

Mounting the crosscut fence in the rear position (**Figure 69**) gives greater stability for crosscutting smaller panels.

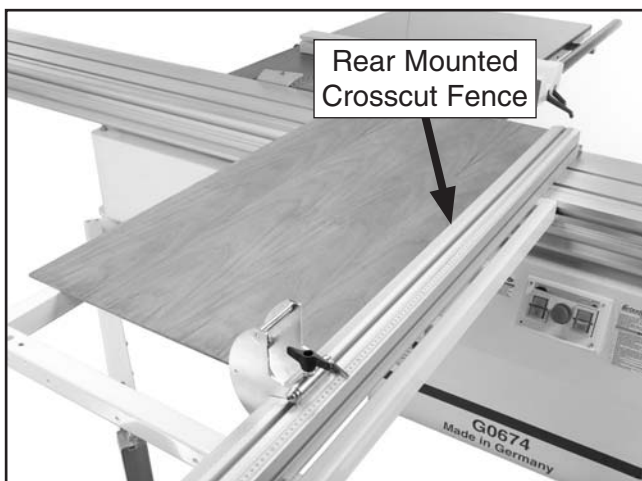


Figure 69. Crosscutting smaller panels.

Lastly, this machine has the capability of crosscutting workpieces while using the rip fence as a cut-off gauge (**Figure 70**).



Figure 70. Crosscutting workpieces using the rip fence as a cut-off gauge (blade guard removed for clarity).

Determine which cutting operation will be best suited for the workpiece to be crosscut.

- If you will be crosscutting full size panels, then skip ahead to **Crosscutting Full Size Panels**.
- If you will be crosscutting smaller panels, then skip ahead to **Crosscutting Smaller Panels**.
- If you will be crosscutting workpieces using the rip fence as a cut-off gauge, then skip ahead to **Crosscutting Using Rip Fence as a Cut-Off Gauge**.

Crosscutting Full Size Panels

1. Install the crosscut fence in the forward mounting location shown in **Figure 71** and lock it in place.

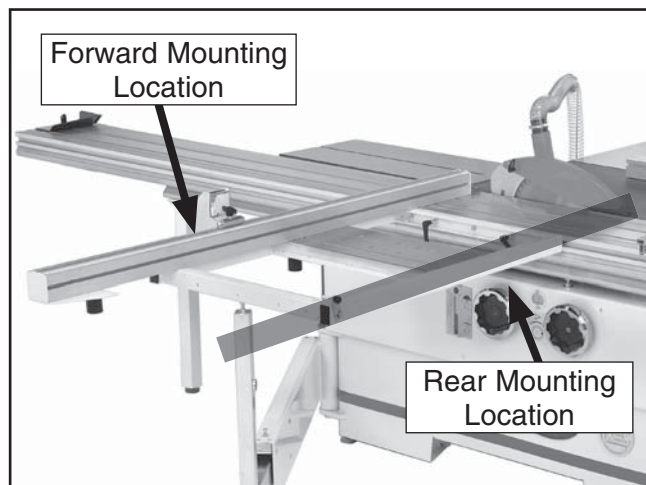


Figure 71. Crosscut fence mounting points.

2. Check to make sure the fence is at 90° and adjust it as described in **Squaring Crosscut Fence to Blade** on **Page 55** if necessary.
3. Set either flip stop to the desired width-of-cut. **Note:** *Extend the crosscut fence slide if necessary.*
4. Load the workpiece onto the table saw. The setup should look similar to **Figure 68**.
5. Once all the necessary safety precautions have been taken, perform the cutting operation.

Crosscutting Smaller Panels

1. Install the crosscut fence in the rear mounting points shown in **Figure 71** and lock it in place.
2. Check to make sure the fence is at 90° and adjust it as described in **Squaring Crosscut Fence to Blade** on **Page 55** if necessary.
3. Set the flip stop to the desired width-of-cut. **Note:** *Extend the crosscut fence slide if the workpiece is more than 74".*

4. Load the workpiece onto the table saw. The set up should look similar to **Figure 69**.
5. Once all the necessary safety precautions have been taken, perform the cutting operation.

Crosscutting Using Rip Fence as a Cut-Off Gauge

1. Install the crosscut fence in the rear mounting points shown in **Figure 71** and lock it in place.
2. Check to make sure the fence is at 90° and adjust it as described in **Squaring Crosscut Fence to Blade** on **Page 55** if necessary.
3. Position the rip fence for the desired width.
4. Load the workpiece onto the table saw. The setup should look similar to **Figure 70**.
5. Slide the leading end of the rip fence behind the front edge of the blade as shown in **Figure 72**. (**This step is critical to reduce the risk of blade binding and kickback.**)

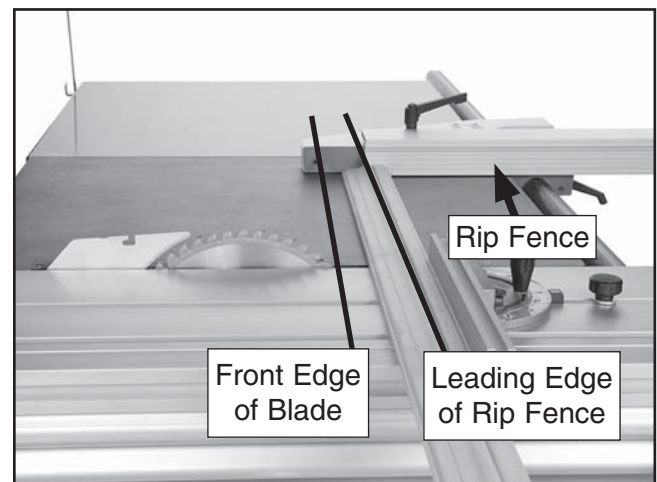


Figure 72. Correct rip fence position when using it as a cut-off gauge (blade guard removed for clarity).

6. Take all the necessary safety precautions, then perform the cutting operation.

Miter Cutting

The crosscut fence allows miter cuts from 0° through 135°. The table-mounted miter scale has a resolution of 1°.

To perform a miter cut:

1. Slide the crosscut table to the front edge of the sliding table and lock it in place.
2. Place the crosscut fence center stud in the forward or rear stud hole of the crosscut table. The fence can be installed as shown in **Figure 73** for 90° to 135° cuts, or as shown in **Figure 74** for 0° to 90° cuts.



Figure 73. Fence set-up for 90° to 135° cuts.

3. Rotate the fence to the desired angle and use the lock knob to lock the fence in place.
4. Position the flip stop according to the length of the workpiece you want to cut off to the left of the blade.
5. Load the workpiece onto the table saw. The set up should look similar to **Figure 74**.



Figure 74. Example of miter cutting operation.

6. Once all the necessary safety precautions have been taken, perform the cutting operation.

SECTION 5: ACCESSORIES

- T20501—Face Shield Crown Protector 4"
- T20502—Face Shield Crown Protector 7"
- T20503—Face Shield Window
- T20448—Economy Clear Safety Glasses
- T20452—"Kirova" Anti-Reflective Glasses
- T20456—"Dakura" Clear Safety Glasses
- H0736—Shop Fox® Safety Glasses

These glasses meet ANSI Z87.1-2003 specifications. Buy extras for visitors or employees. You can't be too careful with shop safety!



Figure 75. Our most popular eye protection.

- T20784—12" Replacement Saw Blade
- Replacement saw blade for the Model G0674 12" Sliding Table Saw.



Figure 76. Replacement main saw blade.

- T20514—Small Half-Mask Respirator
 - T20515—Medium Half-Mask Respirator
 - T20516—Large Half-Mask Respirator
 - T20511—Pre-Filter P100
 - T20539—Cartridge Filter 2PK P100
 - T20541—Cartridge Filter 2PK P100 & O Vapor
- Wood and other types of dust can cause severe respiratory damage. If you work around dust every-day, a half-mask respirator can greatly reduce your risk. Compatible with safety glasses!



Figure 77. Half-mask respirator with disposable cartridge filters.

- T20785—Replacement Scoring Blade Set
- Replacement scoring blade set for the Model G0674 12" Sliding Table Saw.



Figure 78. Replacement scoring blade set.

- G5562—SLIPIT® 1 Qt. Gel
- G5563—SLIPIT® 12 oz Spray
- G2871—Boeshield® T-9 12 oz Spray
- G2870—Boeshield® T-9 4 oz Spray
- H3788—G96® Gun Treatment 12 oz Spray
- H3789—G96® Gun Treatment 4.5 oz Spray



Figure 79. Recommended products for protecting unpainted cast iron/steel part on machinery.

G3445—Precision Saw Tool

This high impact plastic Saw Aid™ quickly measures blade height and angle and can also serve as a solid push stick. Includes a graduated ruler guide and center finder.

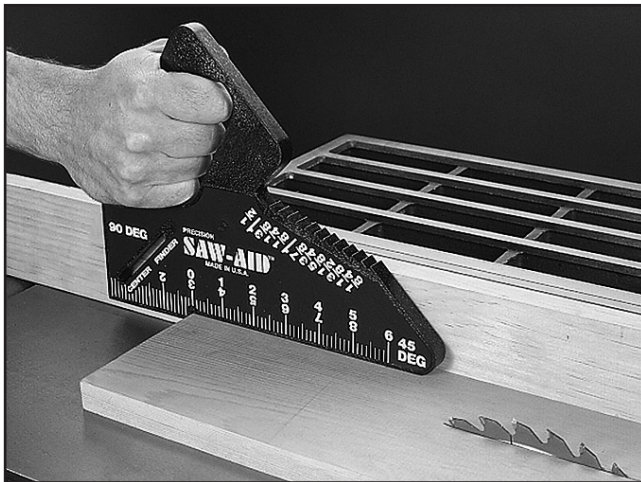


Figure 80. G3445 Precision Saw Tool.

Call 1-800-523-4777 To Order

G7581—Superbar™
G7582—Master Plate

The miter slot mounted Superbar™ will align, tune and calibrate your tablesaw to within ±0.001 in just minutes. Replace your tablesaw blade when calibrating the double disk ground Master Plate for a precision measurement, with no runout!

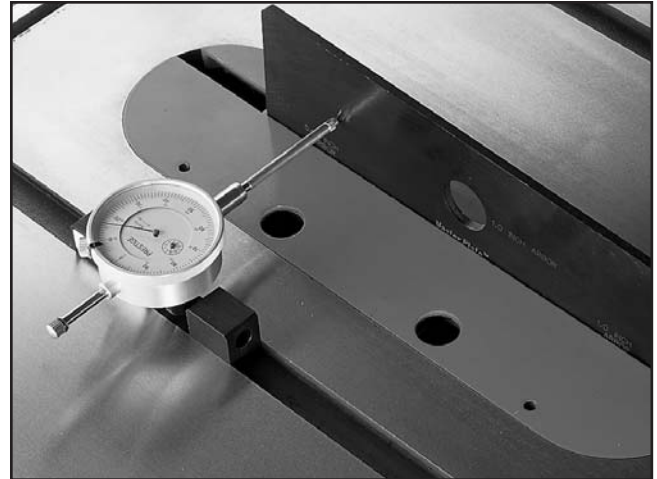


Figure 81. Superbar™ and Master Plate.

- H1049—Clear Flexible Hose 2½" x 10'
- H1052—Clear Flexible Hose 4" x 10'
- G3123—Black Flexible Hose 2½" x 10'
- G1536—Black Flexible Hose 4" x 10'
- G3124—Wire Hose Clamp 2½"
- G2974—Wire Hose Clamp 4"
- G3119—Dust Collection Adapter 2½" x 4"
- G1843—Plastic Blast Gate 4"
- G4679—Anti-Static Grounding Kit
- G7938—Shop Vacuum Adapter 2½" x 2½"

We've hand picked a selection of dust collection components commonly needed to connect the Model G0661 to an existing dust collection system.



Figure 82. Dust collection accessories.



Shop Made Safety Accessories

Push Stick

Using a push stick is essential to safe table saw operations, especially when cutting narrow cuts. The beauty of a push stick is that it keeps your hand well away from the blade during the cut, and if there is contact with the blade, the push stick will take the damage rather than your fingers or hand.

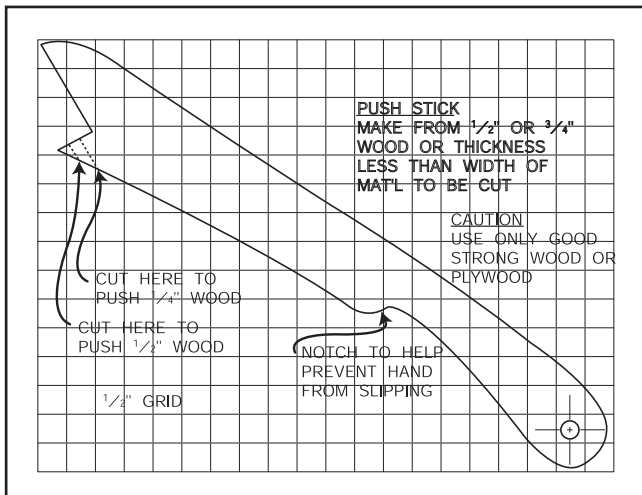


Figure 83. Shop made push stick.

Featherboard

Not only do featherboards make great anti-kick-back devices, but they maintain pressure on the workpiece while cutting, which makes operation easier and safer because the cut can be completed without the operator's hands getting near the blade. When used together with push sticks, the overall risk of injury can be greatly reduced.

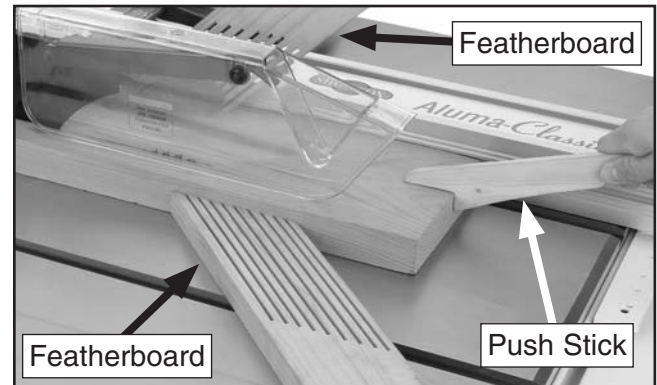
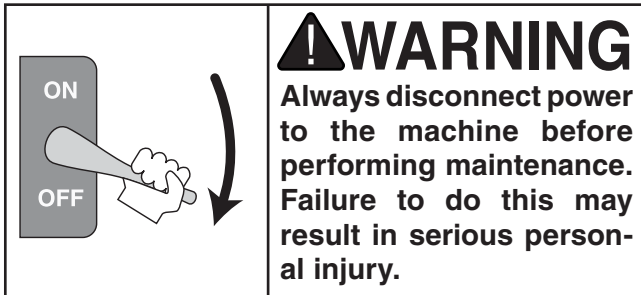


Figure 84. Examples of featherboards in use.

SECTION 6: MAINTENANCE



Schedule

For optimum performance from your machine, follow this maintenance schedule and refer to any specific instructions given in this section.

Daily Check:

- Loose mounting bolts.
- Worn, loose, or damaged saw blades.
- Worn or damaged switches or wires.
- Any other unsafe condition.

Weekly Maintenance:

- Clean sliding table surface and grooves.
- Clean the cast iron saw table.
- Clean the sliding table roller guideways.
- Clean the rip fence and sliding grooves.
- Clean the rip fence bracket.

Monthly Check:

- Clean/vacuum dust buildup from inside cabinet and off motor.
- V-belt tension, damage, or wear.

Note: *To ensure optimum power transmission from the motor to the blades, the V-belts must be in good condition (free from cracks, fraying and wear) and operate under proper tension.*

Cleaning

Cleaning the Model G0674 is relatively easy. Vacuum excess wood chips and sawdust, and wipe off the remaining dust with a dry cloth. Use compressed air to blow dust from between the two sections of the sliding table. If any resin has built up, use a resin dissolving cleaner to remove it. Treat all unpainted cast iron and steel with a non-staining lubricant after cleaning.

Unpainted Cast Iron

Protect the unpainted cast iron surfaces on the table by wiping the table clean after every use—this ensures moisture from wood dust does not remain on bare metal surfaces. **DO NOT** clean cast iron with water or it will rust!

Keep tables rust-free with regular applications of products like G96® Gun Treatment, SLIPIT®, or Boeshield® T-9 (refer to **SECTION 5: ACCESSORIES** on **Page 43** for more details).



Lubrication

The bearings are sealed, pre-lubricated, and require no lubrication during their usable life. All other moving saw components will operate at their best if the bearing surfaces are kept clean. Before applying fresh grease to any surface, clean away dust and grime with a brush and mineral spirits. ALWAYS DISCONNECT POWER BEFORE DOING MAINTENANCE!

Lubricate the areas indicated below with general purpose grease every 6–12 months, depending on frequency of use (see Figure 86):

- Blade Angle Trunnions
- Bevel Gears and Leadscrews
- Blade Height Rails
- Chain
- Extension Shafts & U-Joints

Sliding Table Ways: Spray or wipe on a light machine oil (such as those shown on **Page 43**) the entire length of the steel rods (see **Figure 85**).



Figure 85. Sliding table ways.

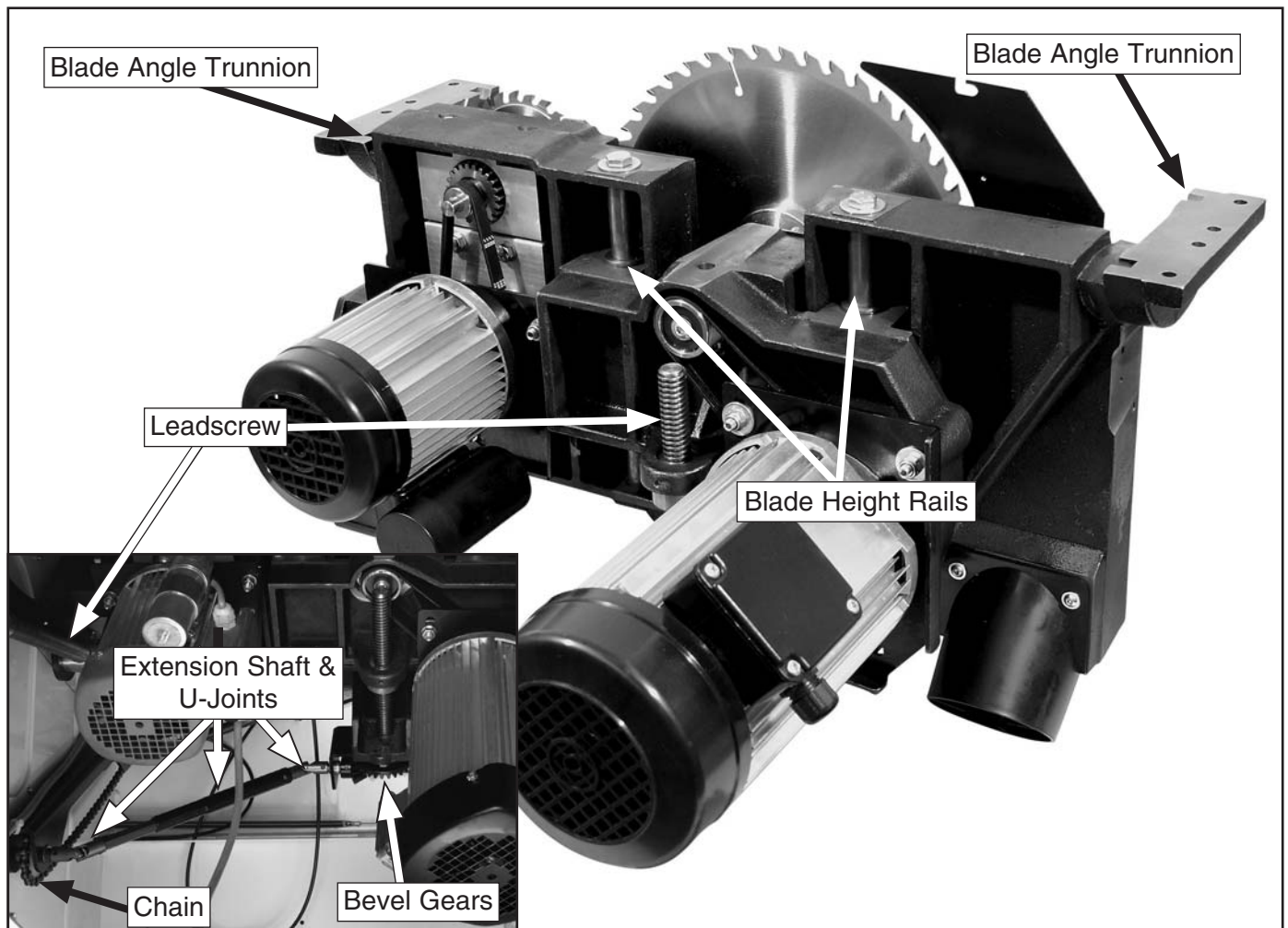


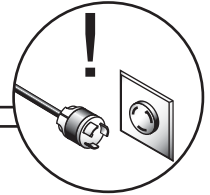
Figure 86. Lubrication locations (assembly removed for clarity).



SECTION 7: SERVICE

Review the troubleshooting and procedures in this section to fix or adjust your machine if a problem develops. If you need replacement parts or you are unsure of your repair skills, then feel free to call our Technical Support at (570) 546-9663.

Troubleshooting



Motor & Electrical

Symptom	Possible Cause	Possible Solution
Machine does not start or a breaker trips.	<ol style="list-style-type: none"> Emergency stop push-button is engaged/faulty. Power supply switched OFF or is at fault. Blade guard limit switch engaged/at fault. Motor connection wired incorrectly. Thermal overload relay has tripped. Wall fuse/circuit breaker is blown/tripped. Wiring is open/has high resistance. Motor ON button or ON/OFF switch is at fault. Motor is at fault. 	<ol style="list-style-type: none"> Rotate clockwise slightly until it pops out/replace it. Ensure power supply is switch on; ensure power supply has the correct voltage. Move blade guard to the working position; replace faulty limit switch. Correct motor wiring connections. Turn cut-out dial to increase working amps and push the reset pin. Replace if tripped multiple times (weak relay). Ensure circuit size is suitable for this machine; replace weak breaker. Check for broken wires or disconnected/corroded connections, and repair/replace as necessary. Replace faulty ON button or ON/OFF switch. Test/repair/replace.
Machine stalls or is underpowered.	<ol style="list-style-type: none"> Feed rate/cutting speed too fast for task. Workpiece material is not suitable for this machine. Belt(s) slipping. Motor connection is wired incorrectly. Motor bearings are at fault. Motor is at fault. 	<ol style="list-style-type: none"> Decrease feed rate/cutting speed. Only cut wood products; make sure moisture content is below 20% and there are no foreign materials in the workpiece. Re-tension/replace bad belt(s). Correct motor wiring connections. Test by rotating shaft; rotational grinding/loose shaft requires bearing replacement. Test/repair/replace.



Symptom	Possible Cause	Possible Solution
Machine has vibration or noisy operation.	<ol style="list-style-type: none"> 1. Motor or component is loose. 2. Blade is at fault. 3. Belt(s) worn or loose. 4. Pulley is loose. 5. Motor mount loose/broken. 6. Machine is incorrectly mounted or sits unevenly. 7. Arbor pulley is loose. 8. Motor fan is rubbing on fan cover. 9. Arbor bearings are at fault. 10. Motor bearings are at fault. 	<ol style="list-style-type: none"> 1. Inspect/replace stripped or damaged bolts/nuts, and re-tighten with thread locking fluid. 2. Replace warped, bent, or twisted blade; resharpen dull blade. 3. Inspect/replace belts (Page 49). 4. Realign/replace shaft, pulley, setscrew, and key as required. 5. Tighten/replace. 6. Adjust leveling feet. 7. Retighten/replace arbor pulley with shaft and thread locking liquid. 8. Replace dented fan cover; replace loose/damaged fan. 9. Replace arbor housing bearings; replace arbor. 10. Test by rotating shaft; rotational grinding/loose shaft requires bearing replacement.
Main blade runs backwards.	<ol style="list-style-type: none"> 1. Two of the power wires are reversed. 	<ol style="list-style-type: none"> 1. Exchange wires R & T in the terminal box.

Operation

Symptom	Possible Cause	Possible Solution
Workpiece has burned edges, binds, or kicks back.	<ol style="list-style-type: none"> 1. Sliding table is not parallel to blade. 2. Blade is warped. 	<ol style="list-style-type: none"> 1. Make sliding table parallel to the blade (Page 54). 2. Replace the blade.
Workpiece has chip out on the bottom edge.	<ol style="list-style-type: none"> 1. Scoring blade height is incorrect. 2. Scoring blade is not aligned with the main blade. 3. Scoring blade kerf does not match the main blade. 	<ol style="list-style-type: none"> 1. Adjust the height of the scoring blade. 2. Align the scoring blade (Page 36). 3. Adjust the scoring blade kerf (Page 36).
Sliding table saw does not cut square.	<ol style="list-style-type: none"> 1. Sliding table is not parallel to blade. 2. Rip fence is not parallel to blade. 3. Crosscut fence is not perpendicular to the blade. 	<ol style="list-style-type: none"> 1. Adjust the sliding table (Page 54). 2. Adjust the rip fence parallel to blade. 3. Adjust the crosscut fence perpendicular to the blade (Page 55).
Fence hits table top when sliding across table.	<ol style="list-style-type: none"> 1. Front rail is too low. 2. Rip fence slider is too low. 	<ol style="list-style-type: none"> 1. Raise the front rail. 2. Adjust the rip fence slider.
Blade does not reach 90°, or blade does not reach 45°.	<ol style="list-style-type: none"> 1. Blade stop bolts are out of adjustment. 	<ol style="list-style-type: none"> 1. Adjust the stop bolts (Page 52).
The rip fence scale is not accurate.	<ol style="list-style-type: none"> 1. The rip fence scale is out of calibration or was not set up correctly. 	<ol style="list-style-type: none"> 1. Adjust the rip fence scale.
Tilt or blade height handwheels difficult to turn.	<ol style="list-style-type: none"> 1. Gears caked with dust. 	<ol style="list-style-type: none"> 1. Clean out dust and grease the gears.



Belt Service

Tools Required	Qty.
Ratchet and Socket Set 12mm.....	1
Small Pry Bar	1

Scoring Belt Tension

1. DISCONNECT THE SAW FROM POWER!
2. Set the blade tilt to 0° and fully lower the blade.
3. Remove the rear cabinet cover by unscrewing the four cap screws that secure it in place.
4. Slightly loosen the three lock nuts that secure the motor plate to the main saw casting (**Figures 87–88**).

Note: The belt tension is set by a spring on the motor plate. Loosening the three lock nuts allows the spring to pull on the motor plate, adjusting the belt tension.

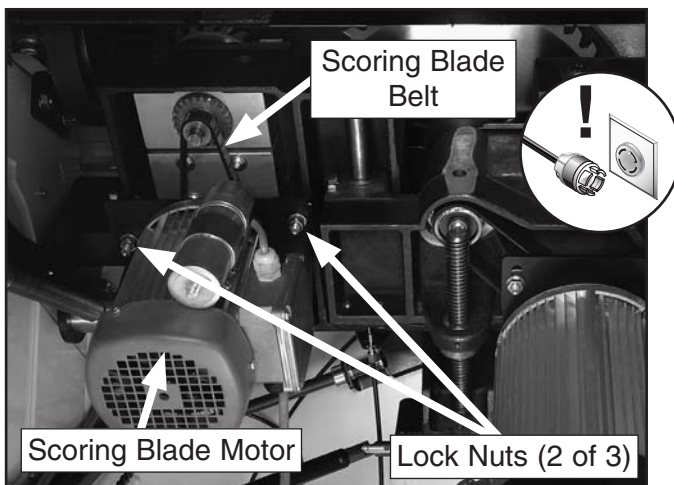


Figure 87. Scoring belt location.

5. Rotate the motor plate by hand to make sure it is moving freely, then allow the spring to retension the belt.
6. Tighten the three lock nuts that were loosened in **Step 4**.

Scoring Belt Replacement

1. Perform **Steps 1–4** of **Scoring Belt Tension**.
2. Place a pry-bar between the motor plate and the main saw casting, as shown in **Figure 88**.

Note: If more than moderate force is required, check for binding or other restrictions. Heavy force is not required to move the motor plate.

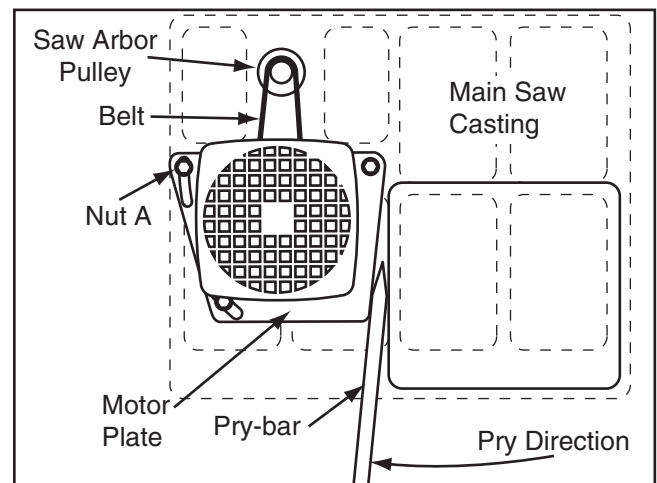


Figure 88. Scoring motor illustration.

3. Pry in the direction shown in **Figure 88** to release tension from the belt, then tighten **Nut A** to lock the motor in this position.
4. Roll the belt off of the saw arbor pulley.
5. Loosen, but do not fully remove the three nuts to provide enough clearance to roll the belt off of the motor pulley, then fully remove the belt.
6. Place the new belt over the motor pulley, then tighten the three nuts until just before they become snug (so the motor plate still moves freely in the vertical plane).
7. Repeat **Step 3**.
8. Place the belt over the top pulley, making sure it is properly positioned.
9. Loosen **Nut A** so the spring re-tensions the belt, then tighten all three nuts.
10. Re-install the rear cabinet cover.



Main Belt Tension

1. DISCONNECT THE SAW FROM POWER!
2. Set the blade tilt to approximately 25° and fully raise the blade.
3. Remove rear cabinet cover by unscrewing the four cap screws that secure it in place.
4. Slightly loosen the four hex nuts so that the motor plate moves freely in the vertical plane (**Figures 89–90**).

Note: The belt tension is set by the weight of the motor. Loosening the four hex nuts allows the motor plate to slide downward, tensioning the belt.

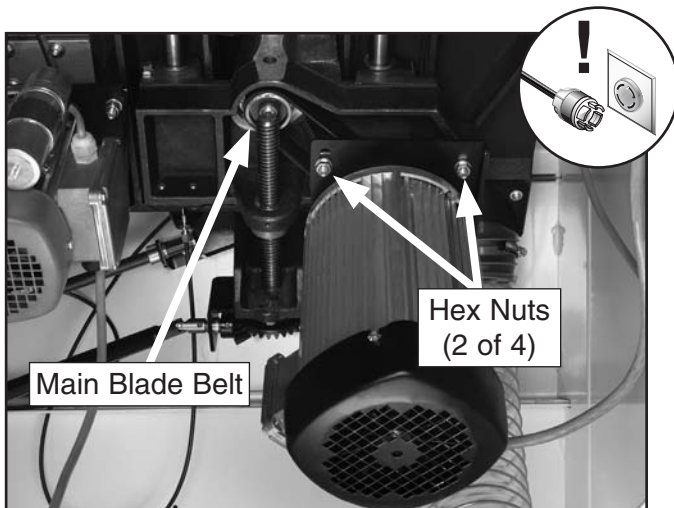


Figure 89. Main belt location.

5. Rotate the motor plate by hand to make sure it is moving freely, then allow the weight of the motor to retension the belt.
6. Tighten the hex nuts that were loosened in **Step 4**.

Main Belt Replacement

1. Perform **Steps 1–4** of **Main Belt Tension**.
2. Lift the motor so that the plate slides upward, releasing the tension from the belt, then tighten **Nut B** (**Figure 90**).

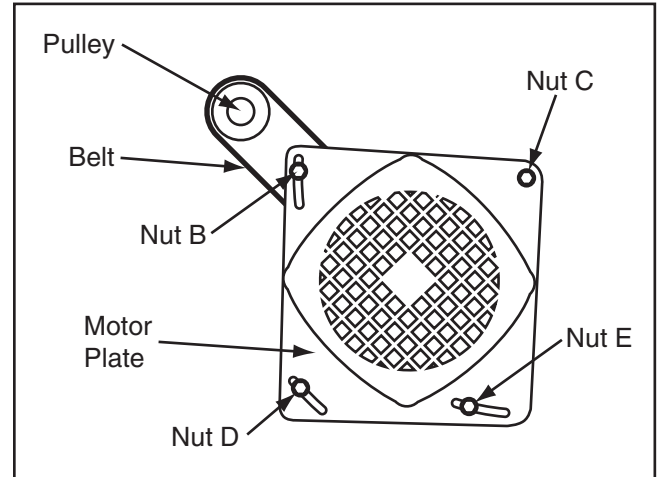


Figure 90. Main motor illustration.

3. Remove the belt from the top pulley.
4. Loosen **Nuts C & E** until they are flush with the ends of the studs.

5. While supporting the motor, fully remove **Nuts B & D**.
6. Allow the motor to swing slightly downward and outward so that it provides enough clearance to remove the belt from the motor pulley.
7. Remove the belt from the motor pulley.
8. Place the new belt over the motor pulley, making sure the belt goes around the main saw casting standoff illustrated in **Figure 91**.
9. Replace **Nuts B & D** and tighten all four nuts until just before they become snug (so the motor plate still moves freely in the vertical plane).
10. Repeat **Step 2**.
11. Slide the belt over the top pulley, making sure it is positioned properly.
12. Loosen **Nut B** and allow the motor's weight to tension the belt.
13. Tighten the four nuts.
14. Re-install the rear cabinet cover.

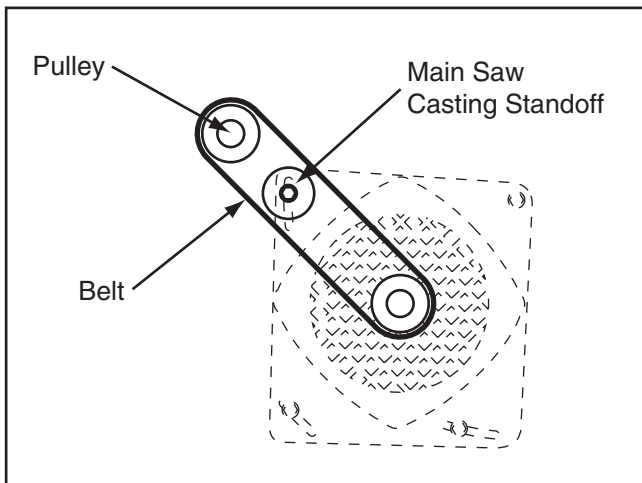


Figure 91. Proper belt routing.

Blade Tilt Calibration

The blade tilt is calibrated at the factory, but can be adjusted if it changes during the life of the machine.

Tools Required	Qty.
Machinist's Square	1
Hex Wrench 4mm.....	1
Wrench 33mm.....	1

90° Stop

1. DISCONNECT SAW FROM POWER!
2. Move the blade tilt to 90° according to the gauge, and raise the main blade as far as it will go.
3. Use a machinist's square to inspect if the blade is square to the table.

—If the blade is not square to the table, loosen the two set screws that secure the 90° tilt stop nut shown in **Figure 92**.

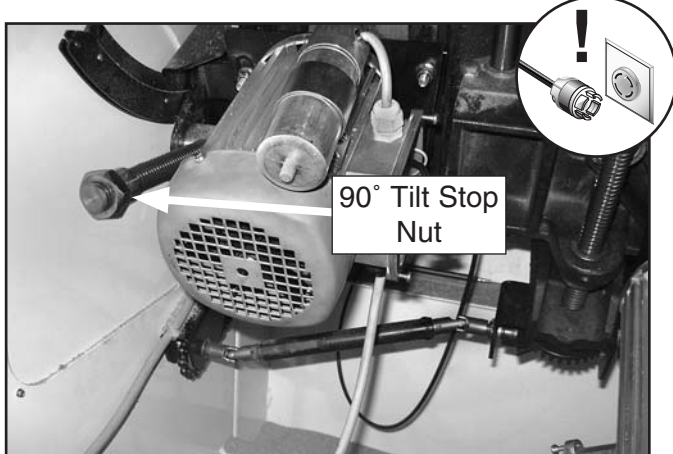


Figure 92. Blade tilt stop nut (90°).

4. Adjust the stop nut and recheck the blade tilt as many times as necessary until the blade is 90° to the table.
5. Tighten the set screw in the stop nut.
6. Check the blade tilt pointer mechanism to ensure that it points to 0°.

—If the blade tilt pointer shows an incorrect tilt, proceed to **Indicator Calibration** on **Page 53**.

45° Stop

1. DISCONNECT SAW FROM POWER!
2. Adjust the blade angle until you hit the 45° positive stop and check the blade angle with a 45° square.

—If the blade is not 45° to the table, loosen the two set screws that secure the 45° tilt stop nut shown in **Figure 93**. (This nut can also be accessed from the front of the saw by moving the sliding table all the way forward.)

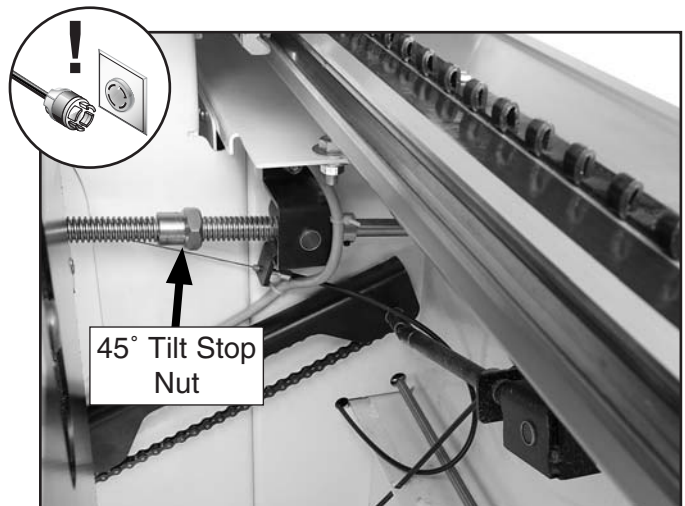


Figure 93. 45° Blade tilt stop nut.

3. Adjust the stop nut and recheck the blade tilt as many times as necessary until the blade is 45° to the table.
4. Tighten the two set screws in the stop nut.



Indicator Calibration

The blade height and angle indicators on the Model G0674 are cable-controlled and with use, may come out of adjustment as the cable stretches slightly. If you find that the values indicated do not match the actual cuts produced, you must calibrate the indicators.

Tools Required	Qty.
Straightedge	1
Wrench 8mm	1

Blade Height indicator

1. DISCONNECT SAW FROM POWER!
2. Move the blade tilt to 90° and lower the main blade as far as it will go.
3. Rotate the main blade by hand until one of the teeth is at its highest point, or top-dead-center (TDC). Place a straightedge on the main table and over the top of the blade.
4. Raise the saw until it just touches the straightedge. At this point, the blade should be just even with the table surface and the blade height indicator should read 0".

—If the indicator reads 0", no further adjustment is necessary.

—If the indicator does not read 0", continue below.
5. Remove the rear cabinet cover, locate the cable adjuster shown in **Figure 94**, loosen the lock nut, and turn the adjuster as needed until the indicator reads exactly 0".

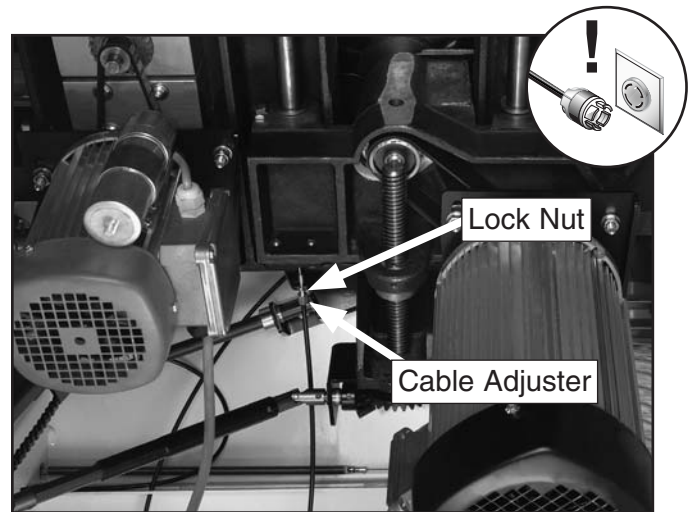


Figure 94. Blade height cable adjuster.

6. Tighten the lock nut, re-install the rear cabinet cover, and remove the straightedge from the table.

Blade Angle indicator

1. DISCONNECT SAW FROM POWER!
2. Move the blade tilt to 90° and raise the main blade as far as it will go.
3. Use a machinist's square set the blade exactly perpendicular to the table surface.
4. Slide the table all the way forward, locate the cable adjuster shown in **Figure 95** on the inner right side of the cabinet, loosen the lock nut and turn the adjuster as needed until the angle indicator reads exactly 0°.

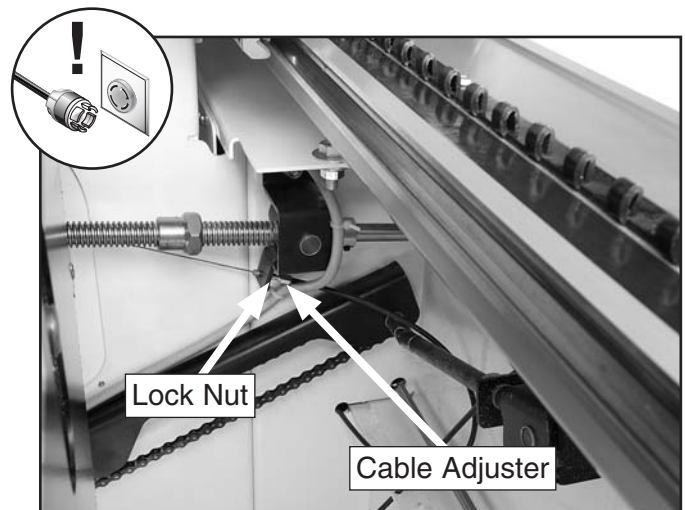


Figure 95. Blade angle cable adjuster.

Sliding Table Parallel Adjustment

The table is calibrated at the factory, but can be adjusted if it changes during the life of the machine.

Tools Required	Qty.
Felt Tip Pen	1
Adjustable Square	1
Feeler Gauge.....	1
Dial Indicator	1

To adjust the sliding table parallel with the main blade:

1. DISCONNECT SAW FROM POWER!
2. Move the blade tilt to 0° (blade 90° to table), and raise the main blade up to maximum height.
3. Mark the edge of the blade with a felt tip pen. This will allow you to take your measurements from the exact same place on the blade.
4. Using an adjustable square or a dial indicator, measure the distance (A) between the miter slot and the front of the blade, as shown in **Figure 96**.

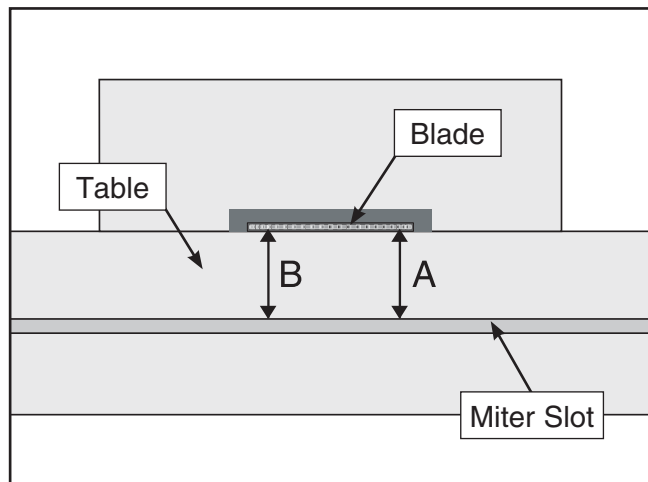


Figure 96. Measuring gap between the table and the blade.

5. Rotate the blade so the mark moves to position B and slide the table with the measuring device to position B.

6. Measure the difference between the two positions (use the feeler gauge if using the adjustable square). Make note of the difference between the two measurements on a piece of paper.

—If the gap is the same on both sides, then the sliding table is already parallel with the main blade.

—If the difference was less than 0.004", then the blade parallelism is correct.

—If the difference was greater than 0.004", then the trunnion assembly below the table needs to be adjusted. Continue with the next step.

7. Loosen all of the sliding table mounting bolts (**Figure 97**).

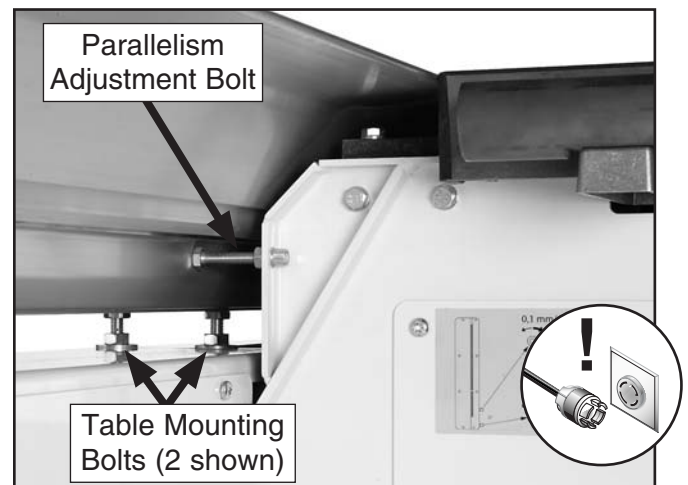


Figure 97. Table parallelism adjustment bolt.

8. Slowly make the adjustments to the parallelism adjustment bolt on the end that is closer to the blade.
9. Repeat **Steps 4-8** until the gap between the blade and the sliding table is equal.
10. Tighten the jam nuts on the parallel adjustment bolts to secure them in place.
11. Tighten the table mounting bolts and replace the access plates.



Squaring Crosscut Fence to Blade

Squaring the crosscut fence to the blade ensures that cuts made with the crosscut fence will be square. This procedure can be done by using a piece of scrap plywood as a test piece and making five test cuts, then adjusting the fence as necessary.

Tools Required	Qty.
Felt Tip Pen	1
Adjustable Square	1
Feeler Gauge.....	1
Dial Indicator	1

To square the crosscut fence with the blade:

1. Make sure the blade is parallel with the sliding table and that the crosscut fence is resting against the 90° stop bolt (see **Figure 99** for locations).
2. Prepare the scrap test piece by cutting it to 32" x 32", then number all four sides of the test piece.
3. Use the crosscut fence to cut 1/2" off of each side of the test piece, then cut side 1 again (make five cuts total).
4. Measure the test piece diagonally from corner-to-corner as shown in **Figure 98**.
 - If both measurements are not within 1/16", then the crosscut fence needs to be adjusted. Proceed to **Steps 5–8**.
 - If both measurements are within 1/16" then you are finished with this procedure.

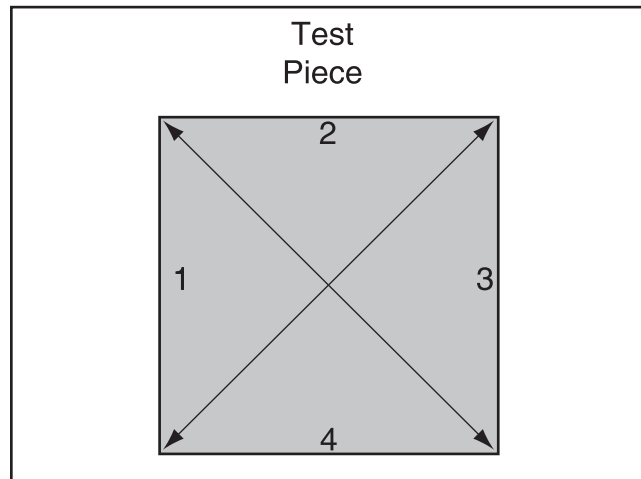


Figure 98. Fence adjustment test piece.

5. Loosen the knob on the crosscut fence to allow it to pivot (make sure the fence remains against the 90° stop bolt during adjustments).
6. Loosen the hex nut on the 90° stop bolt shown in **Figure 99**, and rotate the 90° stop bolt to square the crosscut fence.

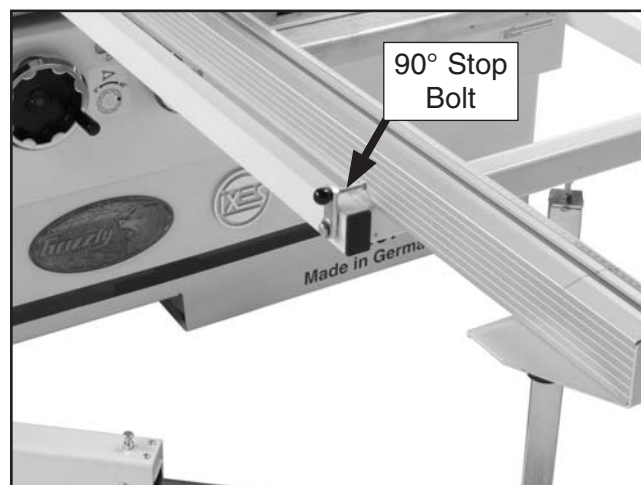


Figure 99. Crosscut fence adjustment bolt.

7. Tighten the hex nut on the 90° stop bolt, then tighten the crosscut fence knob, making sure the block is touching the 90° stop bolt.
8. Repeat **Steps 3-4** until you satisfy the requirements described in **Step 4**.



SECTION 8: WIRING

These pages are current at the time of printing. However, in the spirit of improvement, we may make changes to the electrical systems of future machines. Study this section carefully. If there are differences between your machine and what is shown in this section, call Technical Support at (570) 546-9663 for assistance BEFORE making any changes to the wiring on your machine.

WARNING













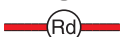
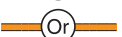

Wiring Safety Instructions

- SHOCK HAZARD.** Working on wiring that is connected to a power source is extremely dangerous. Touching electrified parts will result in personal injury including but not limited to severe burns, electrocution, or death. Disconnect the power from the machine before servicing electrical components!
- QUALIFIED ELECTRICIAN.** Due to the inherent hazards of electricity, only a qualified electrician should perform wiring tasks on this machine. If you are not a qualified electrician, get help from one before attempting any kind of wiring job.
- WIRE CONNECTIONS.** All connections must be tight to prevent wires from loosening during machine operation. Double-check all wires disconnected or connected during any wiring task to ensure tight connections.
- MOTOR WIRING.** The motor wiring shown in these diagrams is current at the time of printing, but it may not match your machine. Always use the wiring diagram inside the motor junction box.
- MODIFICATIONS.** Using aftermarket parts or modifying the wiring beyond what is shown in the diagram may lead to unpredictable results, including serious injury or fire.
- WIRE/COMPONENT DAMAGE.** Damaged wires or components increase the risk of serious personal injury, fire, or machine damage. If you notice that any wires or components are damaged while performing a wiring task, replace those wires or components before completing the task.
- CAPACITORS.** Some capacitors store an electrical charge for up to five minutes after being disconnected from the power source. To avoid being shocked, wait at least this long before working on capacitors.
- CIRCUIT REQUIREMENTS.** You MUST follow the requirements on **Page 12** when connecting your machine to a power source.
- EXPERIENCING DIFFICULTIES.** If you are experiencing difficulties understanding the information included in this section, contact our Technical Support at (570) 546-9663.

NOTICE

The photos and diagrams included in this section are best viewed in color. You can view these pages in color at www.grizzly.com.

COLOR KEY

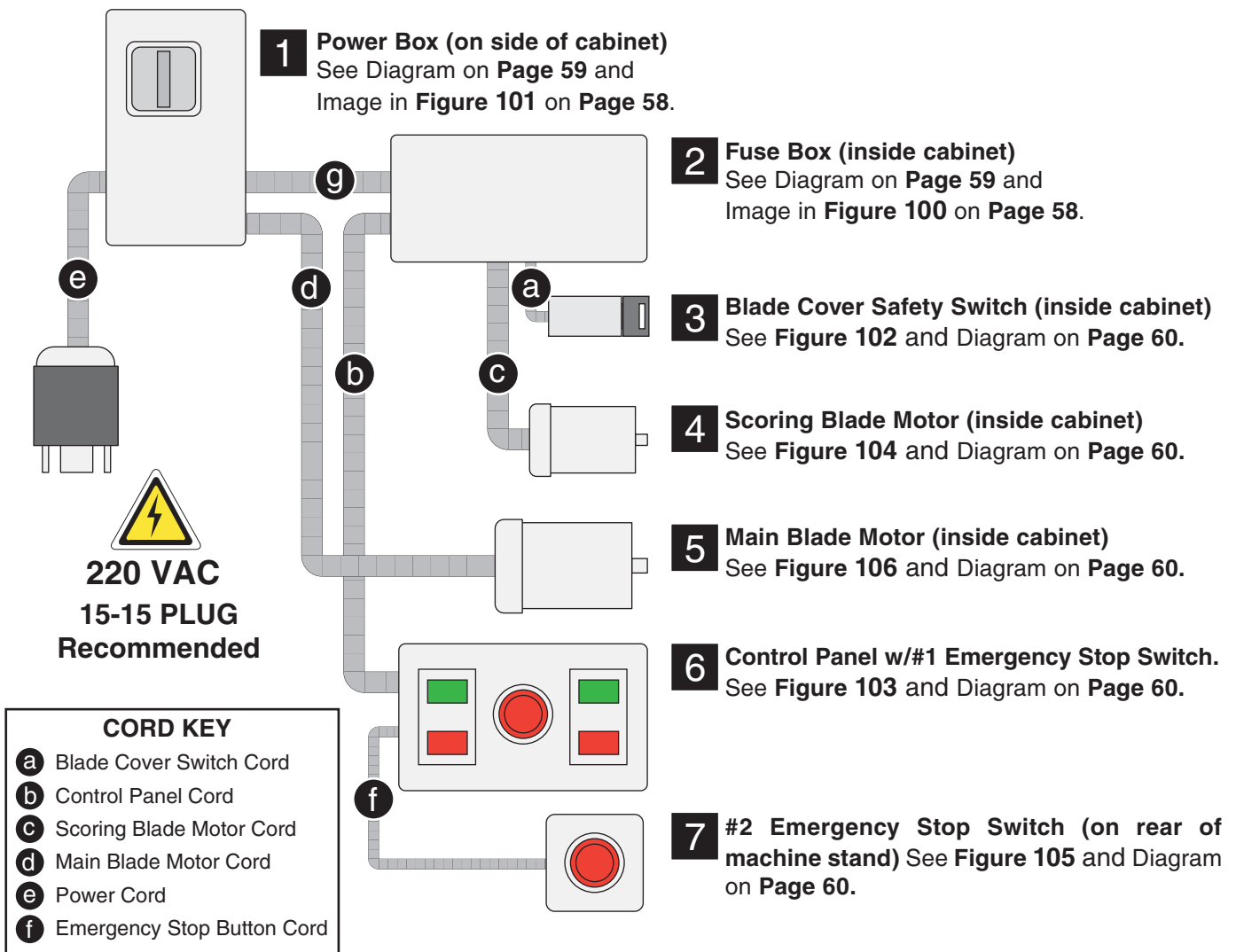
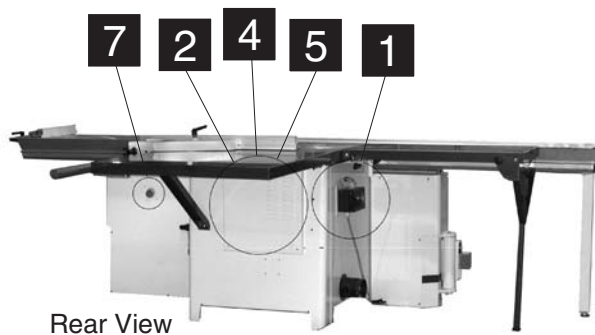
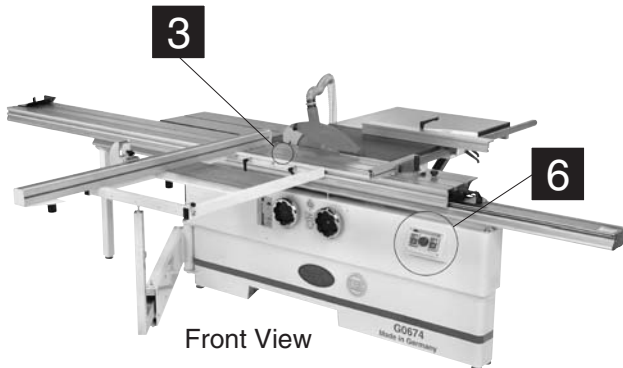
BLACK		BLUE		YELLOW		LIGHT BLUE	
WHITE		BROWN		YELLOW GREEN		BLUE WHITE	
GREEN		GRAY		PURPLE		TURQUOISE	
RED		ORANGE		PINK			



Wiring Overview



View this page in color at www.grizzly.com.



Electrical Box Photos

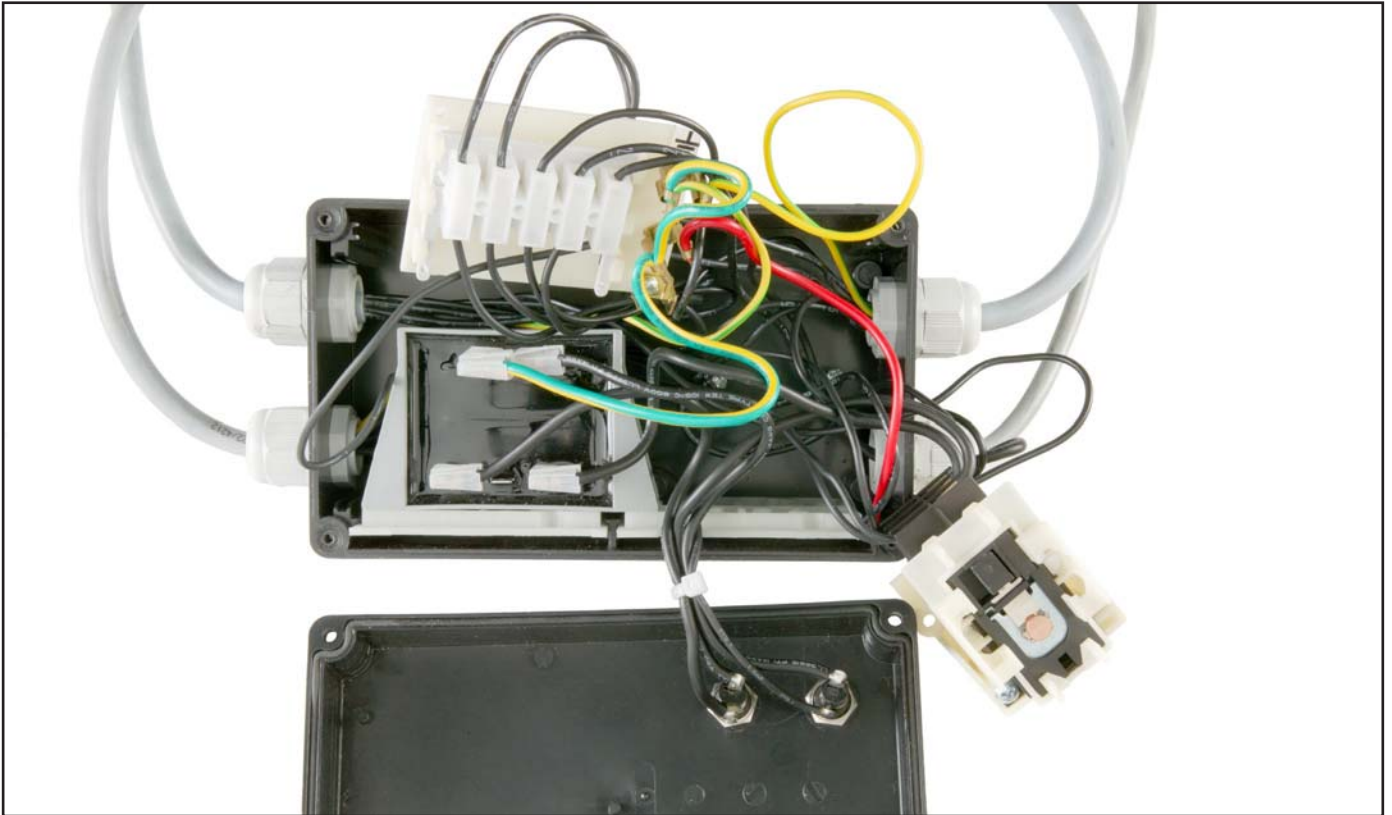


Figure 100. Fuse box wiring.

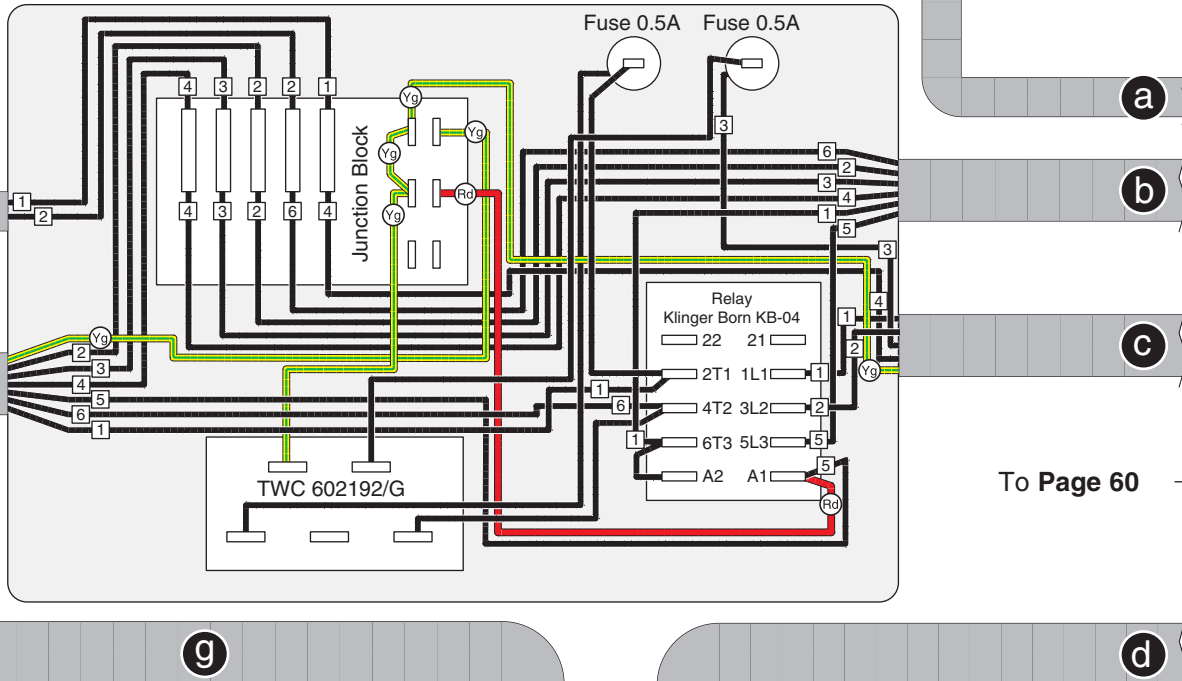


Figure 101. Main switch box wiring.

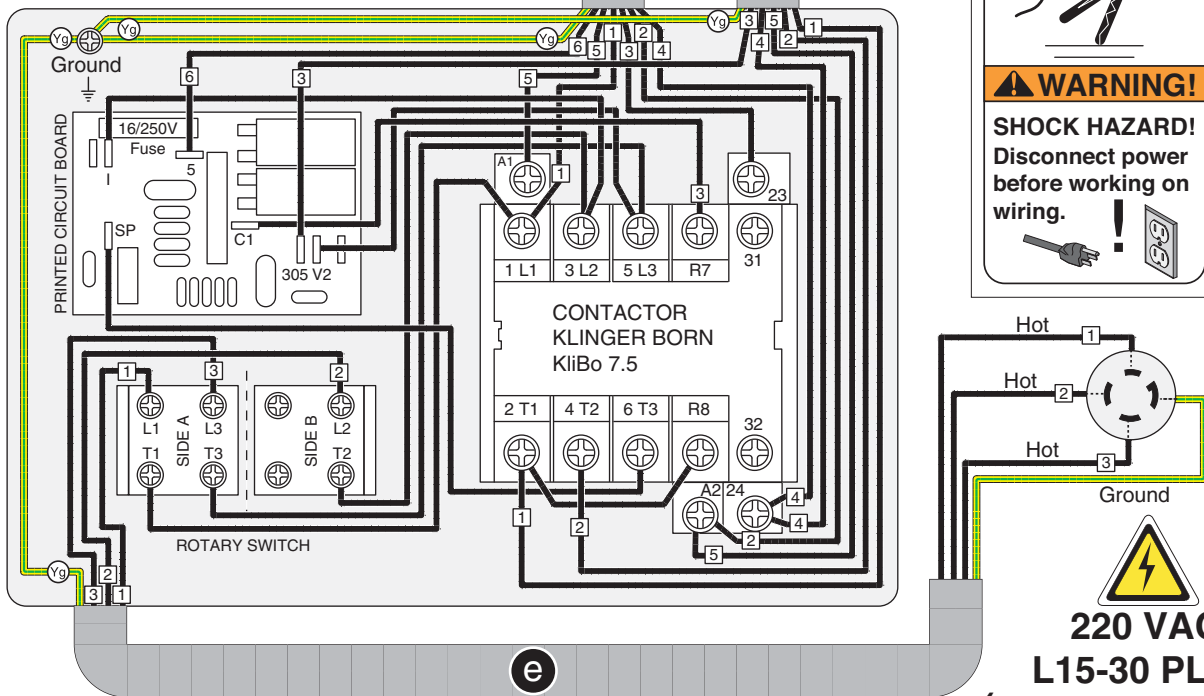


Wiring (Electrical Boxes)

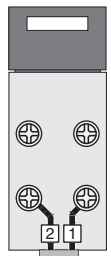
2 Fuse Box
(Figure 100 on Page 58)



1 Power Box
(Figure 101 on Page 58)



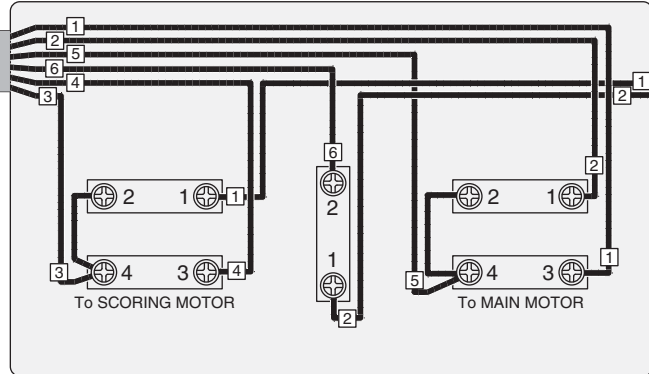
Wiring (Components)



3 Limit Switch
(Figure 102)



Figure 102. Limit Switch.



6 Control Panel
(Figure 103)

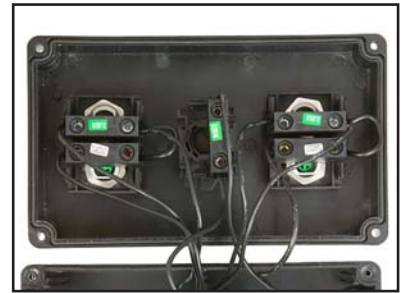
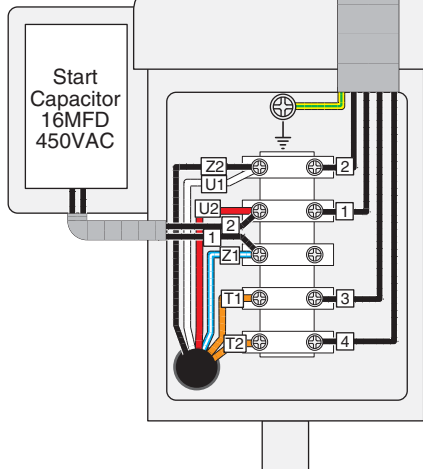


Figure 103. Control panel.

4 Scoring Blade
Motor (Figure 104)



Figure 104. Scoring blade motor.



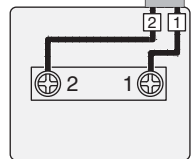
5 Main Blade Motor
(Figure 106)



Figure 106. Main blade motor.

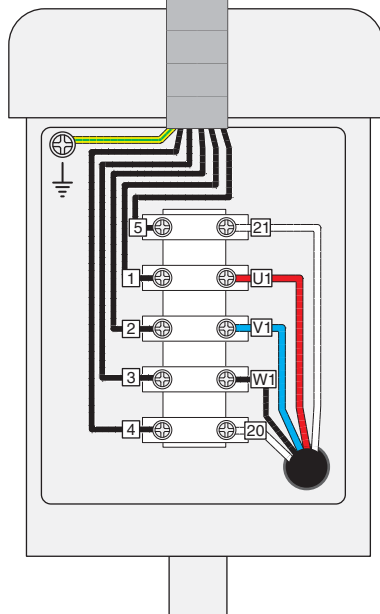


Figure 105. Stop switch.



7 Stop Switch
(Figure 105)

To Page 59

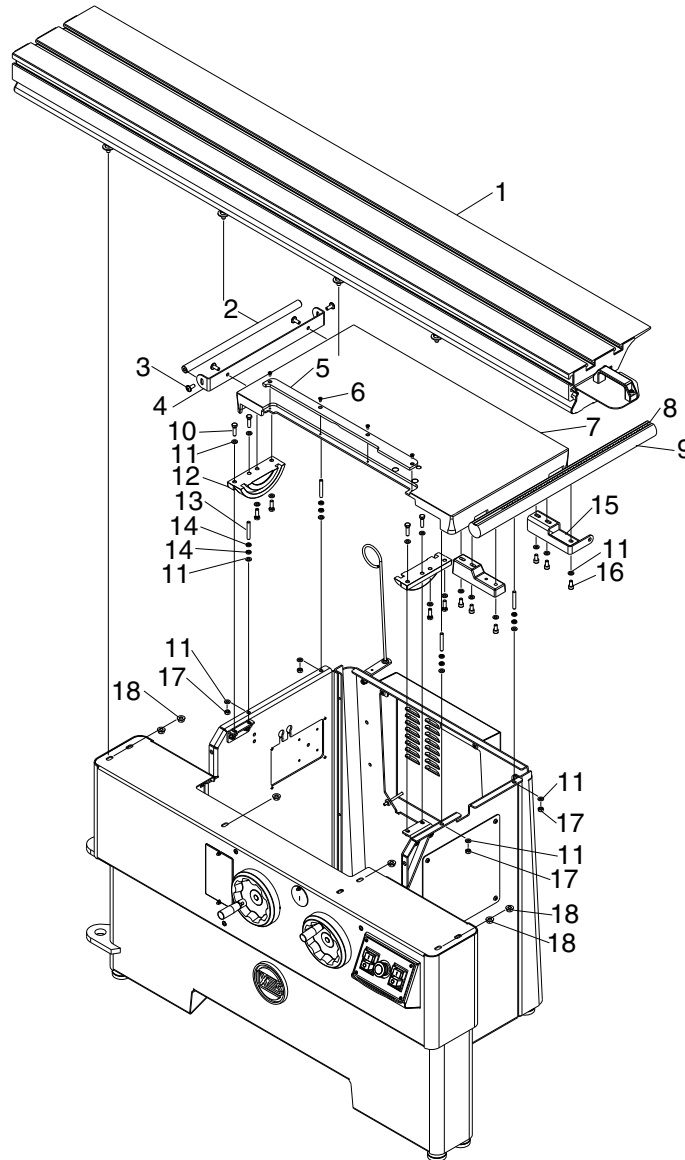


NOTICE
The motor wiring shown here is current at the time of printing, but it may not match your machine. Always use the wiring diagram inside the motor junction box.



SECTION 9: PARTS

Tables Breakdown

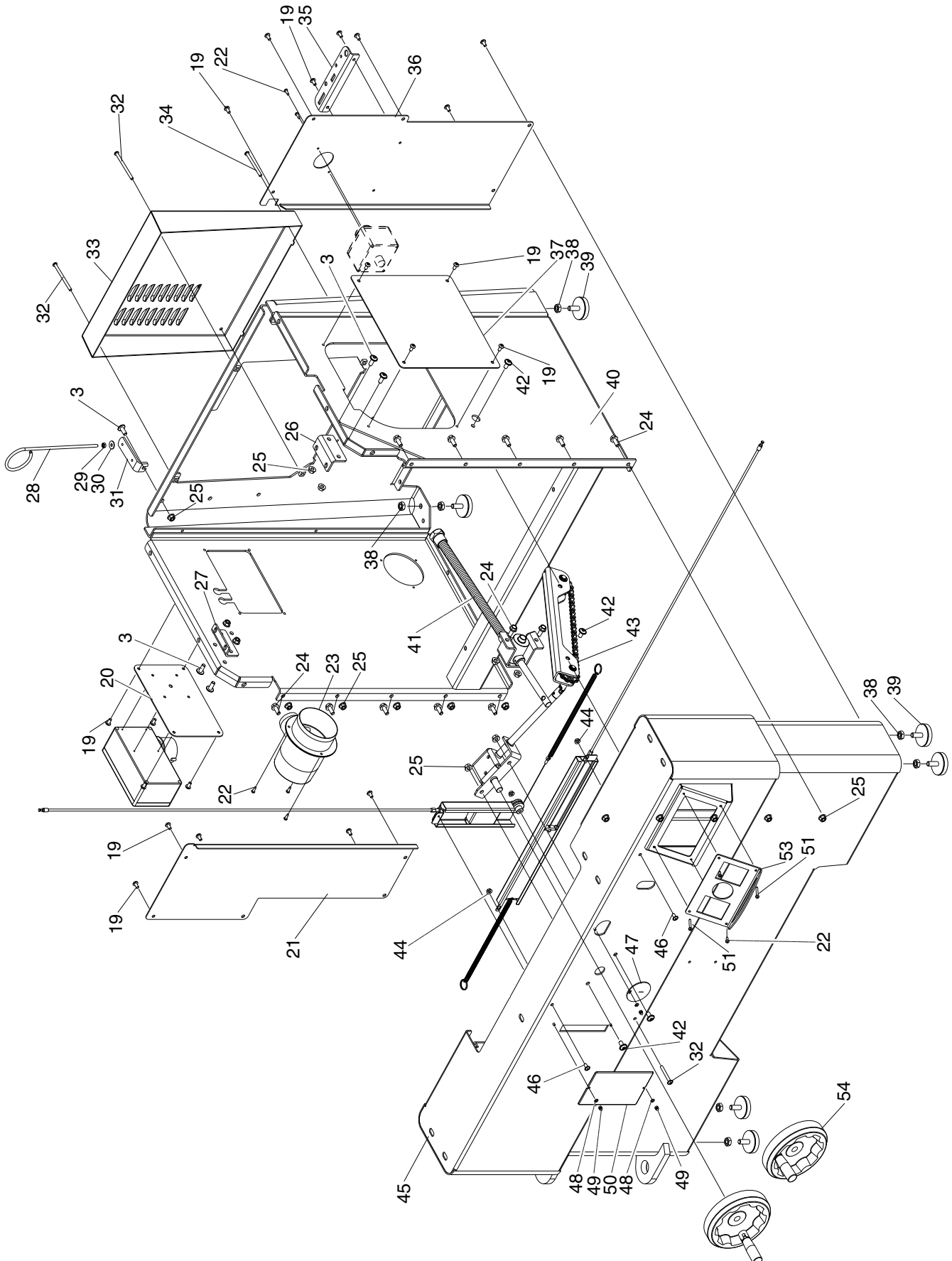


REF	PART #	DESCRIPTION
1	P0674001	SLIDING TABLE COMPLETE 3200MM
2	P0674002	HINGE ROD
3	PSBS22M	BUTTON HD CAP SCR M8-1.25 X 20
4	P0674004	HINGE CLAMP
5	P0674005	TABLE INSERT
6	PFH07M	FLAT HD SCR M5-.8 X 10
7	P0674007	TABLE PLATE
8	P0674008	SCALE
9	P0674009	RIP FENCE RAIL

REF	PART #	DESCRIPTION
10	PB26M	HEX BOLT M8-1.25 X 30
11	PW01M	FLAT WASHER 8MM
12	P0674012	TRUNNION
13	PSS102M	SET SCREW M8-1.25 X 55
14	PN03M	HEX NUT M8-1.25
15	P0674015	BEARING RIGHT WELDED
16	PSB11M	CAP SCREW M8-1.25 X 16
17	PN03M	HEX NUT M8-1.25
18	P0674018	T-NUT M10-1.5



Cabinet Breakdown



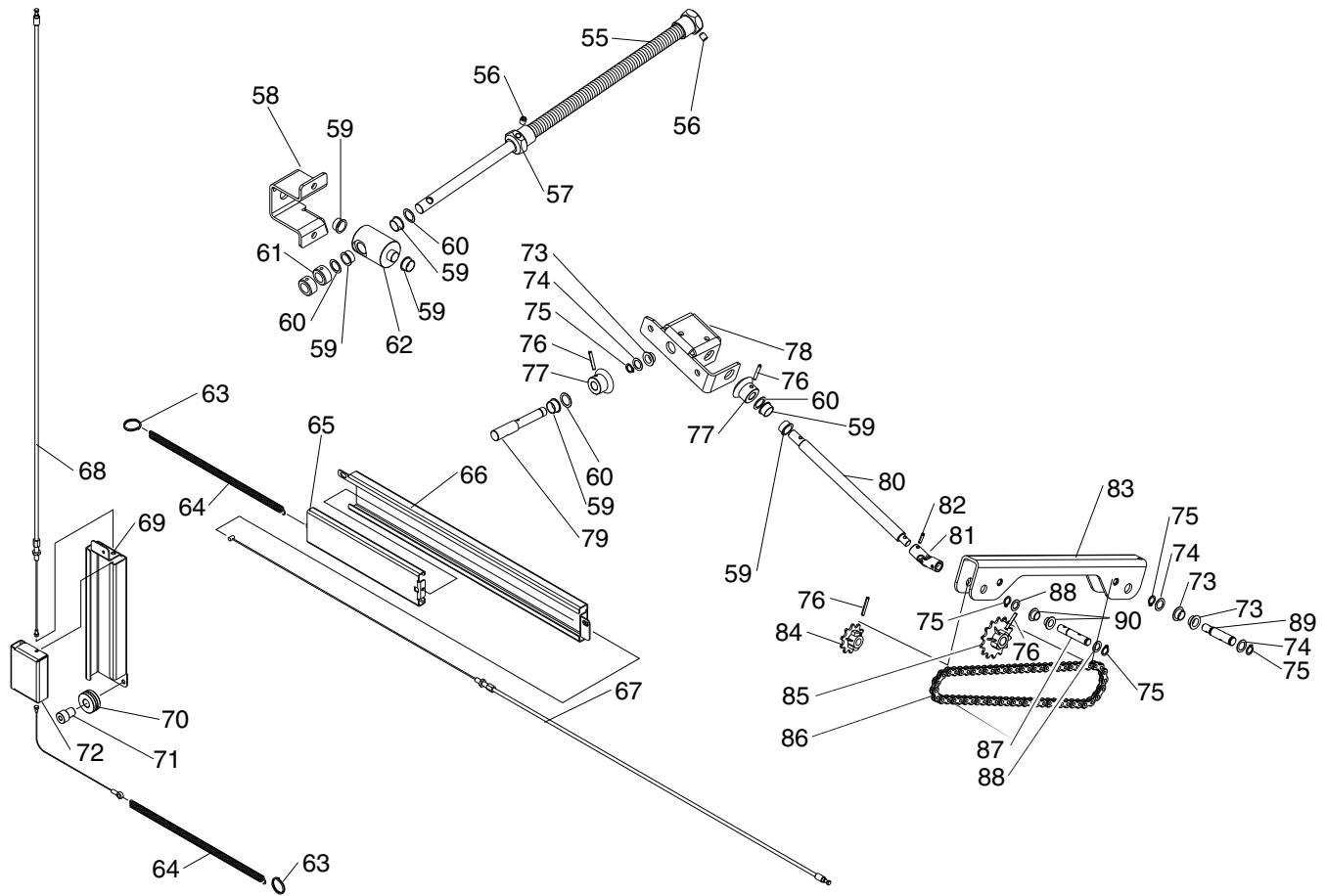
Cabinet Parts List

REF	PART #	DESCRIPTION
3	PSBS22M	BUTTON HD CAP SCR M8-1.25 X 20
19	P0674019	SPECIAL BUTTON HD SCREW
20	P0674020	SWITCH COVER
21	P0674021	REAR COVER
22	PSBS26M	BUTTON HD CAP SCR M4-.7 X 12
23	P0674023	DUST PORT
24	PFB18M	FLANGE BOLT M8-1.25 X 20
25	PFN01M	FLANGE NUT M8-1.25
26	P0674026	FRONT BRACKET
27	P0674027	REAR BRACKET
28	P0674028	SUPPORTING BAR
29	PN01M	HEX NUT M6-1
30	PW03M	FLAT WASHER 6MM
31	P0674031	DUST HOSE HOLDER PLATE
32	PSBS28M	BUTTON HD CAP SCR M6-1 X 50
33	P0674033	CABINET REAR COVER
34	PSBS29M	BUTTON HD CAP SCR M6-1 X 30
35	P0674035	TOOL HOLDER

REF	PART #	DESCRIPTION
36	P0674036	REAR PANEL
37	P0674037	SIDE PANEL
38	PN02M	HEX NUT M10-1.5
39	P0674039	LEVELING FOOT
40	P0674040	REAR CABINET FRAME
41	P0674041	TRUNNION TILT ASSEMBLY
42	PSBS03M	BUTTON HD CAP SCR M8-1.25 X 16
43	P0674043	BLADE HEIGHT ASSEMBLY
44	PFN02M	FLANGE NUT M6-1
45	P0674045	FRONT CABINET FRAME
46	PSBS09M	BUTTON HD CAP SCR M6-1 X 12
47	P0674047	ANGLE DISPLAY WINDOW
48	PW05M	FLAT WASHER 4MM
49	PN45M	ACORN NUT M4-.7
50	P0674050	HEIGHT DISPLAY WINDOW
51	PSBS30M	BUTTON HD CAP SCR M4-.7 X 30
53	P0674053	CONTROL PANEL COVER
54	P0674054	HANDWHEEL 160MM



Control Components Breakdown

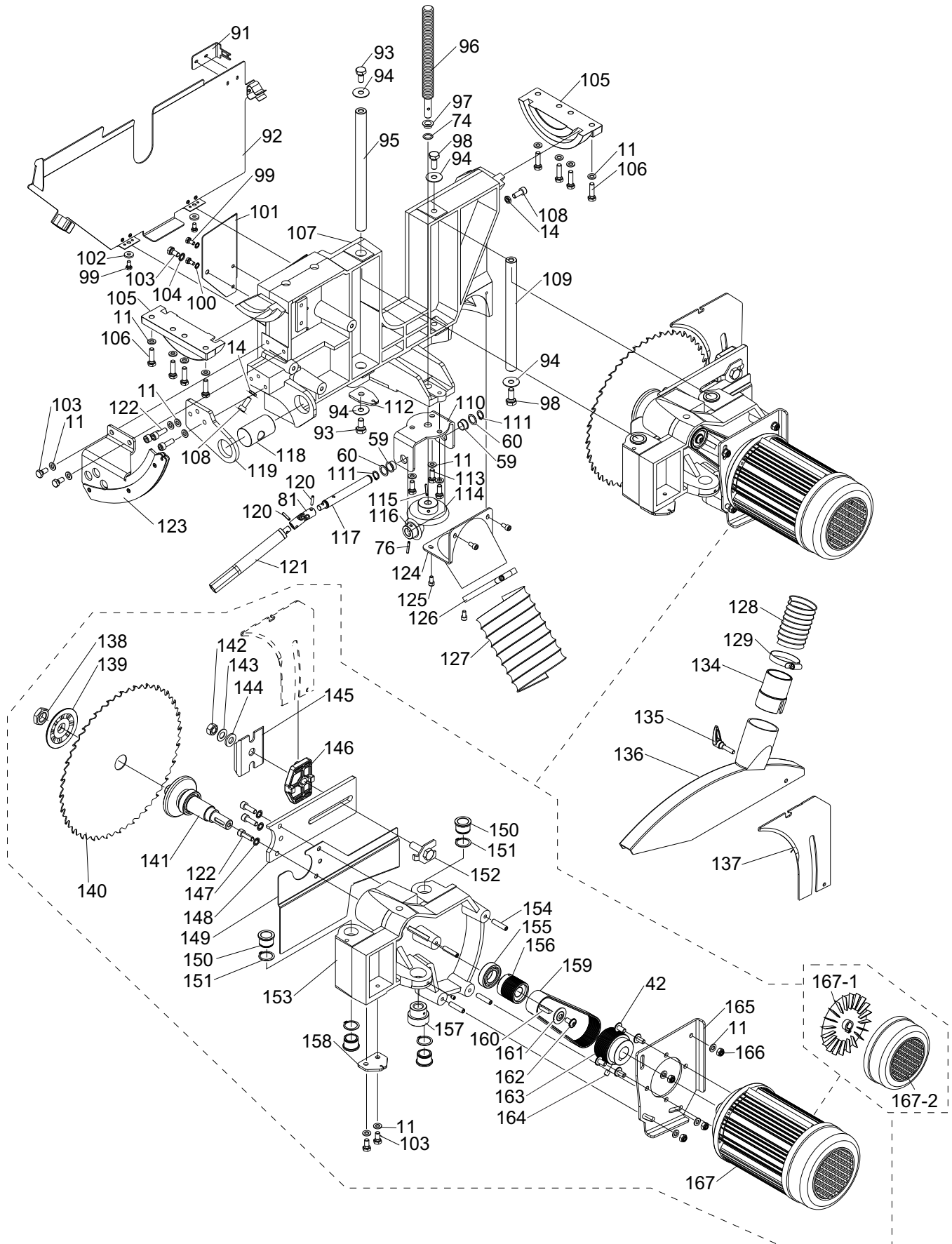


REF	PART #	DESCRIPTION
55	P0674055	THREADED SPINDLE
56	PSS20M	SET SCREW M8-1.25 X 8
57	P0674057	SPECIAL NUT
58	P0674058	BEARING BRACKET
59	P0674059	COLLAR BUSHING
60	P0674060	SHIM
61	P0674061	LOCK COLLAR
62	P0674062	BUSHING BRACKET
63	P0674063	SPIRAL RING
64	P0674064	TENSION SPRING
65	P0674065	SCALE SLIDE
66	P0674066	SCALE GUIDE
67	P0674067	CABLE SHEATH (ANGLE)
68	P0674068	CABLE SHEATH (HEIGHT)
69	P0674069	HEIGHT SCALE GUIDE
70	P0674070	CABLE PULLEY
71	P0674071	PULLEY BUSHING
72	P0674072	HEIGHT SCALE SLIDE

REF	PART #	DESCRIPTION
73	P0674073	BUSHING
74	P0674074	SHIM
75	PR01M	EXT RETAINING RING 10MM
76	PRP56M	ROLL PIN 4 X 25
77	P0674077	BEVEL GEAR 16T
78	P0674078	GEAR BRACKET
79	P0674079	HANDWHEEL SHAFT
80	P0674080	DRIVE SHAFT
81	P0674081	UNIVERSAL JOINT
82	PRP76M	ROLL PIN 4 X 16
83	P0674083	SPROCKET HOLDER
84	P0674084	SPROCKET 10T
85	P0674085	SPROCKET 14T
86	P0674086	CHAIN
87	P0674087	DRIVE SHAFT (CHAIN DRIVE)
88	P0674088	SHIM
89	P0674089	DRIVE SHAFT (SHORT)
90	P0674090	BUSHING



Trunnion Breakdown



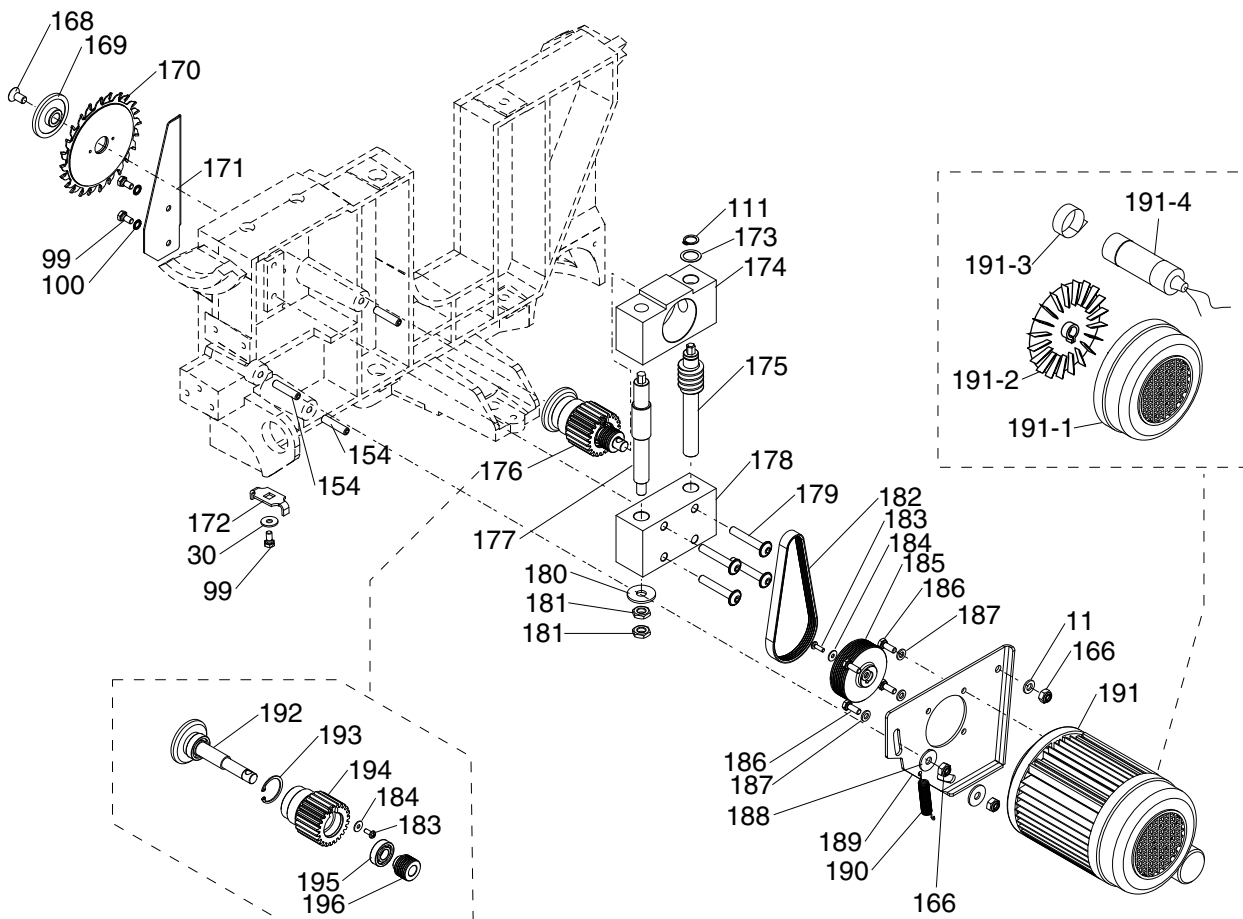
Trunnion Parts List

REF	PART #	DESCRIPTION
11	PW01M	FLAT WASHER 8MM
14	PN03M	HEX NUT M8-1.25
42	PSBS03M	BUTTON HD CAP SCR M8-1.25 X 16
59	P0674059	COLLAR BUSHING
60	P0674060	SHIM
74	P0674074	SHIM
76	PRP56M	ROLL PIN 4 X 25
81	P0674081	UNIVERSAL JOINT
91	P0674091	LIMIT SWITCH PLATE
92	P0674092	BLADE COVER
93	PB74M	HEX BOLT M10-1.5 X 20
94	PW04M	FLAT WASHER 10MM
95	P0674095	GUIDE SHAFT
96	P0674096	THREADED SPINDLE
97	P0674097	BUSHING
98	PB32M	HEX BOLT M10-1.5 X 25
99	PB02M	HEX BOLT M6-1 X 12
100	PTLW05M	EXT TOOTH WASHER 6MM
101	P0674101	DUST SHIELD
102	PW03M	FLAT WASHER 6MM
103	PB03M	HEX BOLT M8-1.25 X 16
104	PTLW07M	EXT TOOTH WASHER 8MM
105	P0674105	TRUNNION
106	PB26M	HEX BOLT M8-1.25 X 30
107	P0674107	MAIN SAW CASTING
108	PSB14M	CAP SCREW M8-1.25 X 20
109	P0674109	GUIDE SHAFT (SHORT)
110	P0674110	GEAR BRACKET (ELEVATION)
111	PR02M	EXT RETAINING RING 14MM
112	P0674112	GUIDE SHAFT BRACKET
113	PB09M	HEX BOLT M8-1.25 X 20
114	P0674114	BEVEL GEAR 30T
115	PRP22M	ROLL PIN 4 X 32
116	P0674116	BEVEL GEAR 15T
117	P0674117	DRIVE SHAFT
118	P0674118	LEADSCREW NUT
119	P0674119	HOLDER PLATE
120	PRP39M	ROLL PIN 4 X 20
121	P0674121	DRIVE SHAFT (SPLINED)
122	PSB31M	CAP SCREW M8-1.25 X 25
123	P0674123	CABLE GUIDE
124	P0674124	DUST PORT (90 DEGREE)

REF	PART #	DESCRIPTION
125	PSB26M	CAP SCREW M6-1 X 12
126	P0674126	HOSE CLAMP 4"
127	P0674127	HOSE 4" X 32"
128	P0674128	HOSE 2" X 10'
129	P0674129	HOSE CLAMP 2"
134	P0674134	HOSE ADAPTOR
135	P0674135	CLAMP LEVER
136	P0674136	BLADE GUARD
137	P0674137	RIVING KNIFE
138	P0674138	ARBOR NUT M20-2.5 LH
139	P0674139	WHEEL FLANGE
140	P0674140	SAW BLADE 14" 48T
141	P0674141	ARBOR
142	PN09M	HEX NUT M12-1.75
143	PLW05M	LOCK WASHER 12MM
144	PW06M	FLAT WASHER 12MM
145	P0674145	RIVING KNIFE CLAMP PLATE
146	P0674146	INTERMEDIATE PLATE
147	PTLW07M	EXT TOOTH WASHER 8MM
148	P0674148	RIVING KNIFE HOLDER
149	P0674149	BAFFLE
150	P0674150	BUSHING
151	PR11M	EXT RETAINING RING 25MM
152	P0674152	FACE PLATE
153	P0674153	MOTOR REST
154	P0674154	STUD SCREW M8-1.25 X 40
155	P60052RS	BALL BEARING 6005-2RS
156	P0674156	ARBOR PULLEY
157	P0674157	THREADED BUSHING
158	P0674158	HINGE PLATE
159	P0674159	FLAT BELT 12PJX483
160	PK143M	KEY 6 X 6 X 25
161	P0674161	SPECIAL WASHER
162	PSB115M	BUTTON HD CAP SCR M6-1 X 16
163	P0674163	MOTOR PULLEY
164	PSS16M	SET SCREW M8-1.25 X 10
165	P0674165	MOTOR PLATE
166	PLN04M	LOCK NUT M8-1.25
167	P0674167	MOTOR 6-1/2HP 220V 3-PH
167-1	P0674167-1	MOTOR FAN
167-2	P0674167-2	MOTOR FAN COVER



Scoring Blade Breakdown

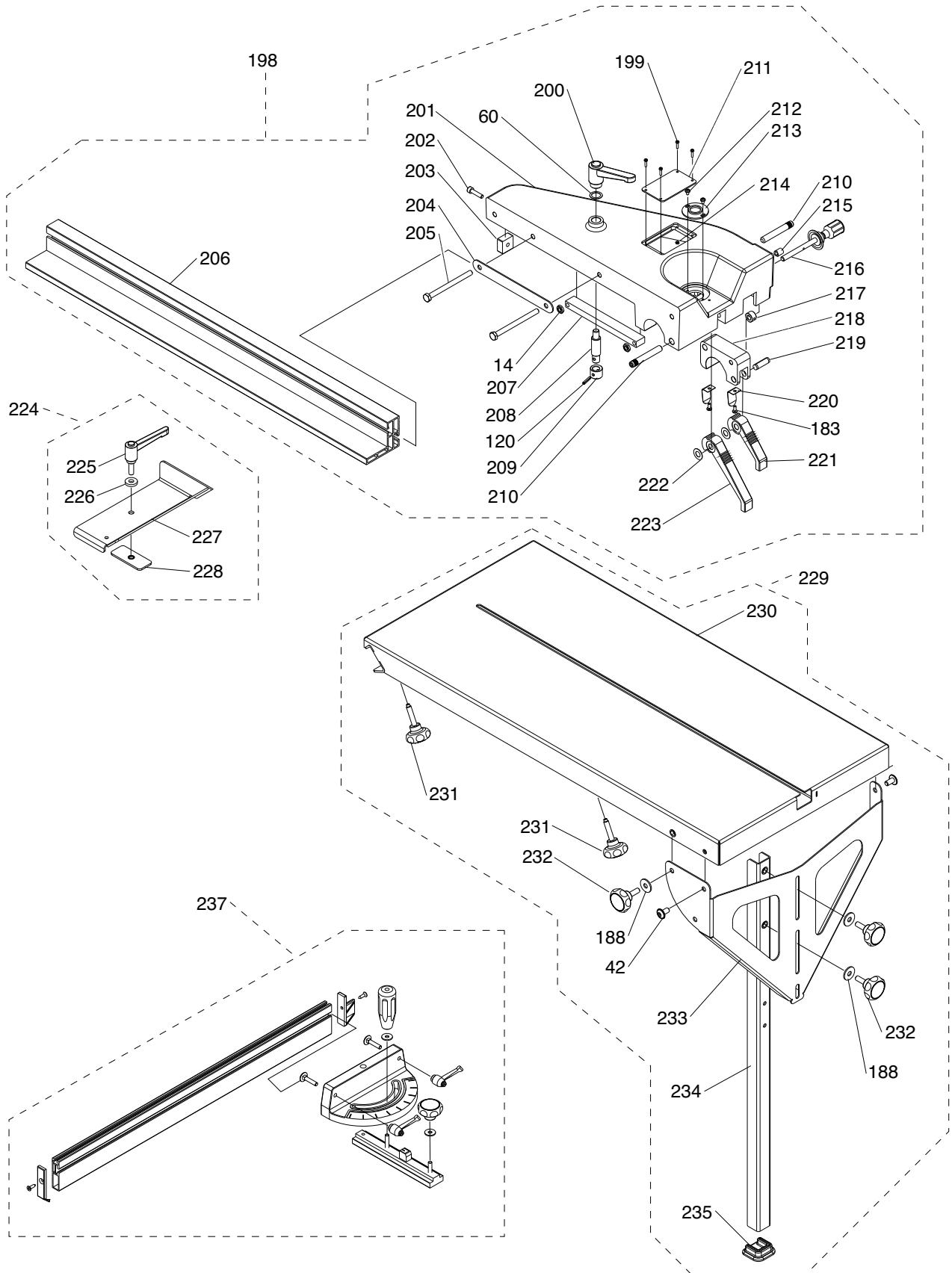


REF	PART #	DESCRIPTION
11	PW01M	FLAT WASHER 8MM
30	PW03M	FLAT WASHER 6MM
99	PB02M	HEX BOLT M6-1 X 12
100	PTLW05M	EXT TOOTH WASHER 6MM
111	PR02M	EXT RETAINING RING 14MM
154	P0674154	STUD SCREW M8-1.25 X 40
166	PLN04M	LOCK NUT M8-1.25
173	P0674173	SHIM
168	PFH23M	FLAT HD SCR M8-1.25 X 16
169	P0674169	SCORING BLADE FLANGE
170	P0674170	SCORING BLADE STACK
171	P0674171	DUST SHIELD
172	P0674172	GUIDE BRACKET
173	P0674173	SHIM
174	P0674174	ADJUSTABLE BLOCK
175	P0674175	WORM SHAFT
176	P0674176	SCORING ARBOR
177	P0674177	ADJUSTABLE SPINDLE
178	P0674178	GUIDE BLOCK
179	PSBS31M	BUTTON HD CAP SCR M8-1.25 X 50
180	PW04M	FLAT WASHER 10MM

REF	PART #	DESCRIPTION
181	P0674181	SPECIAL HEX NUT M10-1.5
182	P0674182	FLAT BELT 5PJX362
183	PSBS24M	BUTTON HD CAP SCR M4-.7 X 10
184	PW05M	FLAT WASHER 4MM
185	P0674185	MOTOR PULLEY
186	PB83M	HEX BOLT M6-1 X 16
187	PW03M	FLAT WASHER 6MM
188	PW01M	FLAT WASHER 8MM
189	P0674189	SCORING MOTOR PLATE
190	P0674190	TENSION SPRING
191	P0674191	MOTOR 1HP 220V 1-PH
191-1	P0674191-1	MOTOR FAN COVER
191-2	P0674191-2	MOTOR FAN
191-3	P0674191-3	CAPACITOR HOLDER
191-4	P0674191-4	S CAPACITOR 16M 450V
192	P0674192	SCORING BLADE ARBOR
193	PR20M	INT RETAINING RING 28MM
194	P0674194	ARBOR HOUSING
195	P6001	BALL BEARING 6001ZZ
196	P0674196	SCORING ARBOR PULLEY



Accessory Breakdown



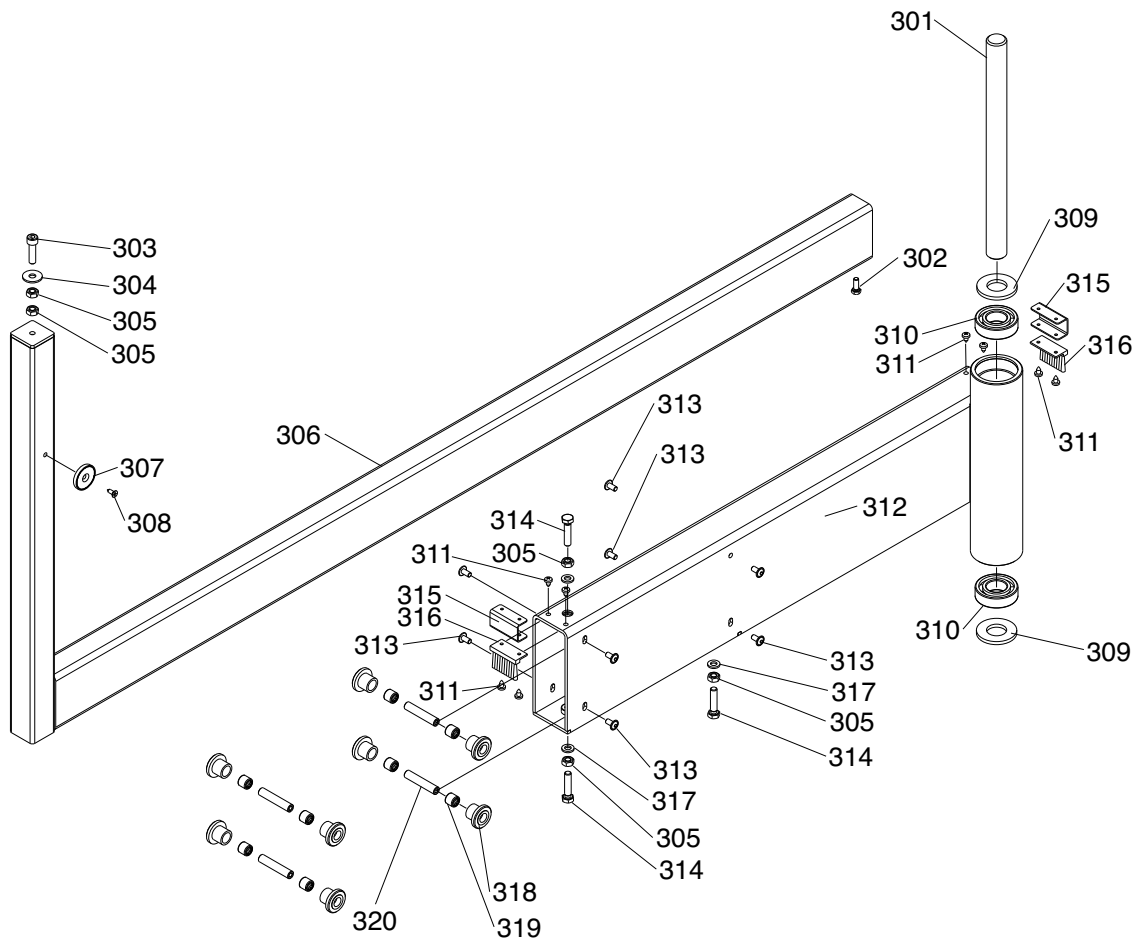
Accessory List

REF	PART #	DESCRIPTION
14	PN03M	HEX NUT M8-1.25
42	PSBS03M	BUTTON HD CAP SCR M8-1.25 X 16
60	P0674060	SHIM
120	PRP39M	ROLL PIN 4 X 20
183	PSBS24M	BUTTON HD CAP SCR M4-.7 X 10
188	PW01M	FLAT WASHER 8MM
198	P0674198	RIP FENCE ASSEMBLY
199	PSBS32M	BUTTON HD CAP SCR M3-.5 X 12
200	P0674200	FENCE LOCK LEVER
201	P0674201	RIPPING FENCE BODY
202	PSB06M	CAP SCREW M6-1 X 25
203	P0674203	FENCE SLIDER
204	P0674204	CLAMPING PLATE
205	PB45M	HEX BOLT M8-1.25 X 100
206	P0674206	FENCE RAIL
207	P0674207	DRAW PLATE
208	P0674208	CLAMP BOLT
209	P0674209	ECCENTRIC BUSHING
210	P0674210	GUIDE BOLT
211	P0674211	COVER
212	PSBS33M	BUTTON HD CAP SCR M4-.7 X 6
213	P0674213	MAGNIFYING GLASS
214	PN07M	HEX NUT M3-.5

REF	PART #	DESCRIPTION
215	P0674215	FINE ADJUSTMENT INDICATOR
216	P0674216	ADJUSTABLE SPINDLE
217	P0674217	SPINDLE BUSHING
218	P0674218	CLAMP BLOCK
219	P0674219	SHAFT 10 X 30
220	P0674220	SPRING CLIP
221	P0674221	ECCENTRIC LEVER (SHORT)
222	P0674222	SPACER
223	P0674223	ECCENTRIC LEVER (LONG)
224	P0674224	EDGING ATTACHMENT ASSEMBLY
225	P0674225	CLAMP LEVER M8-1.25 X 25
226	PW01M	FLAT WASHER 8MM
227	P0674227	EDGING FENCE
228	P0674228	CLAMP PLATE
229	P0674229	TABLE EXTENSION ASSEMBLY
230	P0674230	TABLE
231	P0674231	KNOB M8-1.25 X 40
232	P0674232	KNOB M8-1.25 X 25
233	P0674233	LEG BRACKET
234	P0674234	LEG
235	P0674235	FOOT
237	P0674237	CROSS CUTTING GAUGE ASSEMBLY



Outrigger Breakdown

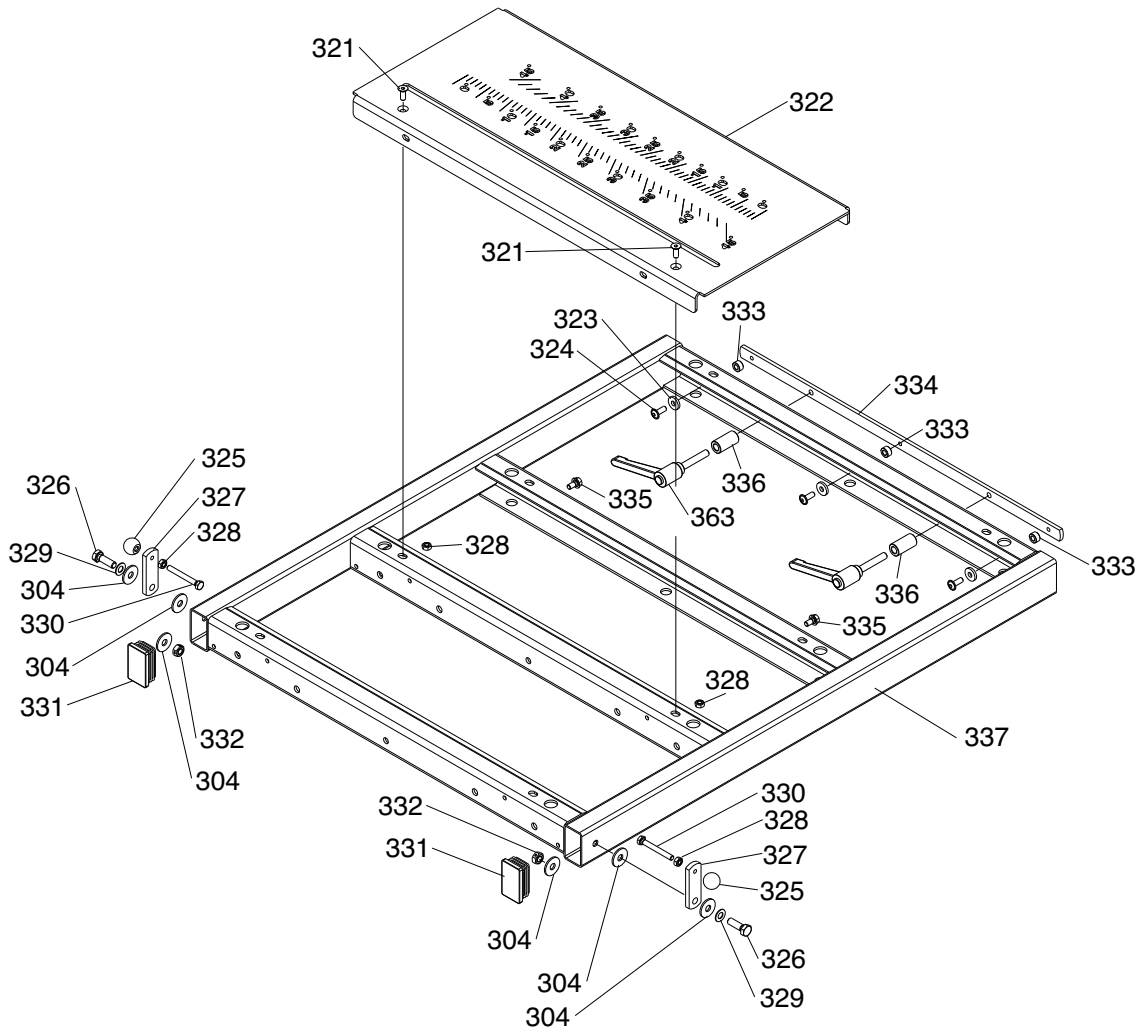


REF	PART #	DESCRIPTION
301	P0674301	SHAFT
302	PB83M	HEX BOLT M6-1 X 16
303	PSB45M	CAP SCREW M8-1.25 X 45
304	PW01M	FLAT WASHER 8MM
305	PN03M	HEX NUT M8-1.25
306	P0674306	EXTENSION
307	P0674307	MAGNETIC CLAMP
308	PHTEK39M	TAP SCREW M4 X 12
309	PW19M	FLAT WASHER 25MM
310	P6205A	BALL BEARING 6205RS

REF	PART #	DESCRIPTION
311	P0674311	SPECIAL SCREW
312	P0674312	ARM BASE
313	PSBS03M	BUTTON HD CAP SCR M8-1.25 X 16
314	PB30M	HEX BOLT M8-1.25 X 55
315	P0674315	BRUSH HOLDER
316	P0674316	BRUSH
317	PW01M	FLAT WASHER 8MM
318	P0674318	GUIDE ROLLER
319	P0674319	NEEDLE BEARING
320	P0674320	ROLLER SHAFT



Crosscut Table Breakdown

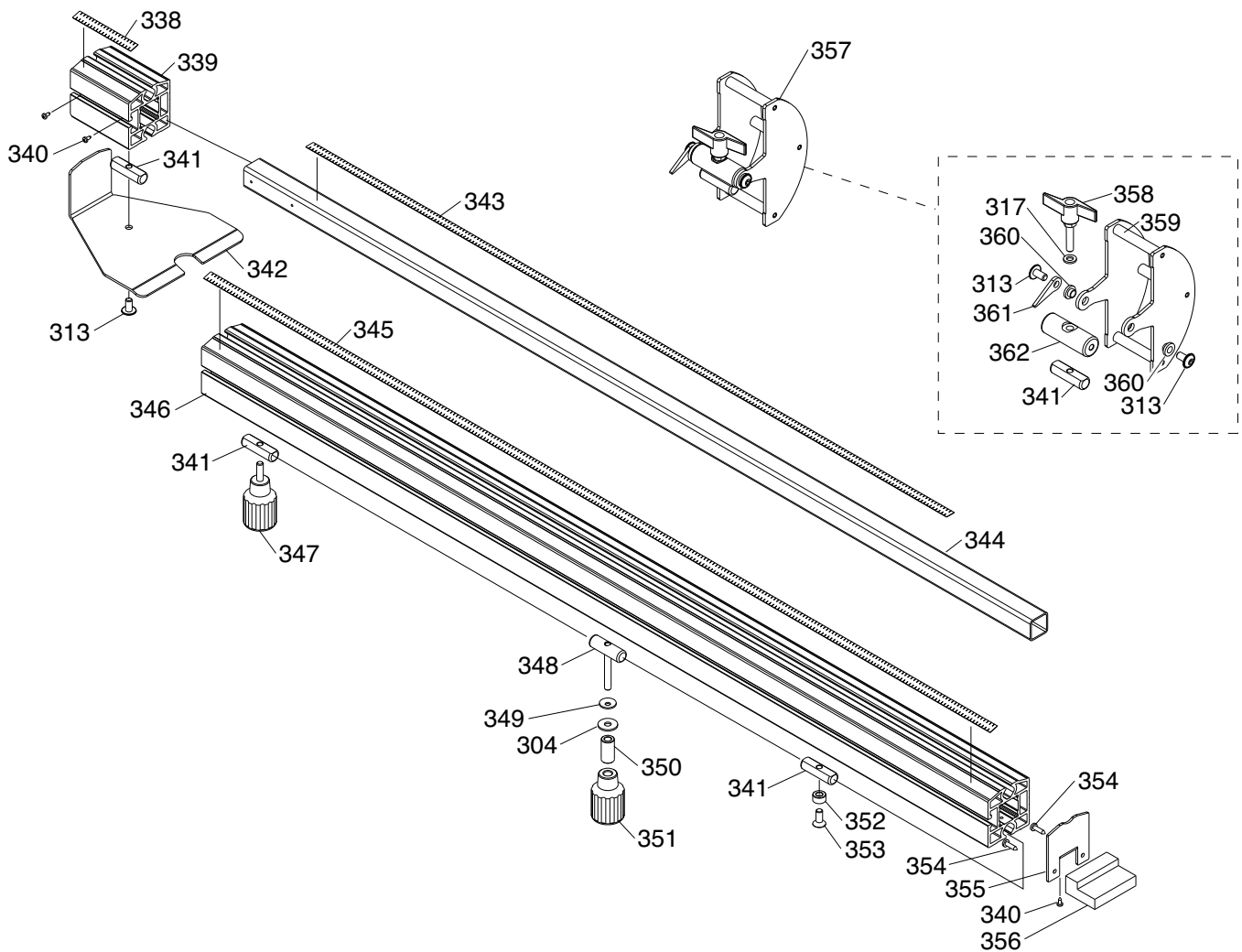


REF	PART #	DESCRIPTION
304	PW01M	FLAT WASHER 8MM
321	PFH38M	FLAT HD SCR M6-1 X 16
322	P0674322	SCALE PLATE
323	PW03M	FLAT WASHER 6MM
324	PSB115M	BUTTON HD CAP SCR M6-1 X 16
325	P0674325	BALL KNOB
326	PB07M	HEX BOLT M8-1.25 X 25
327	P0674327	FENCE PLATE
328	PN01M	HEX NUT M6-1
329	PLW04M	LOCK WASHER 8MM

REF	PART #	DESCRIPTION
330	PB39M	HEX BOLT M6-1 X 50
331	P0674331	END CAP
332	PLN04M	LOCK NUT M8-1.25
333	P0674333	SPACER
334	P0674334	CLAMPING BAR
335	P0674335	SPECIAL FLANGE BOLT
336	P0674336	SPACER (LONG)
337	P0674337	CROSSCUT TABLE
363	P0674363	LOCK HANDLE



Extension Fence Breakdown

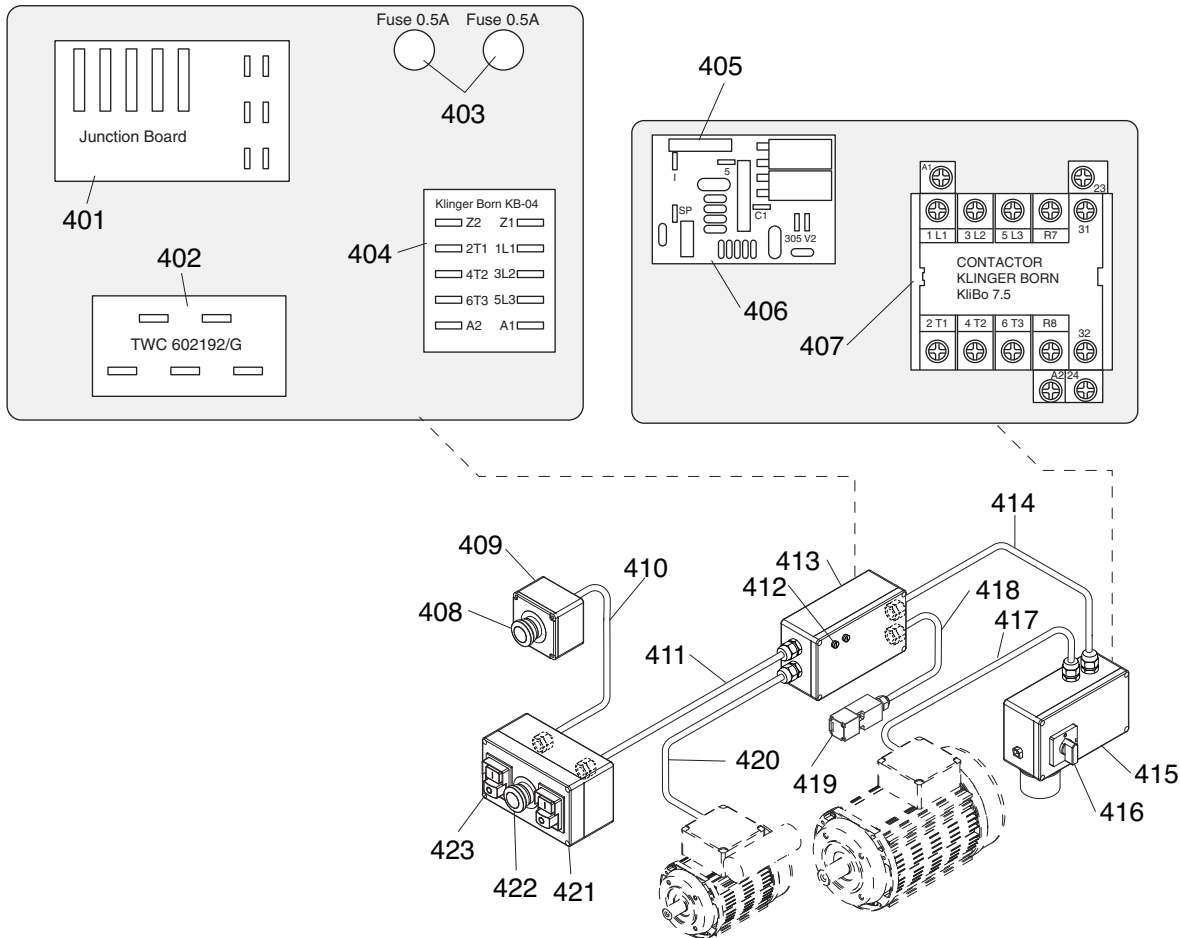


REF	PART #	DESCRIPTION
304	PW01M	FLAT WASHER 8MM
313	PSBS03M	BUTTON HD CAP SCR M8-1.25 X 16
317	PW01M	FLAT WASHER 8MM
338	P0674338	SCALE END STOP
339	P0674339	FENCE END CAP
340	P0674340	SPECIAL SCREW
341	P0674341	BASE NUT
342	P0674342	WORKPIECE REST PLATE
343	P0674343	PULLOUT SCALE
344	P0674344	PULLOUT RAIL
345	P0674345	SCALE FENCE RAIL
346	P0674346	FENCE RAIL
347	P0674347	KNOB M8-1.25 X 25
348	P0674348	BASE SHAFT

REF	PART #	DESCRIPTION
349	P0674349	SPECIAL WASHER 8MM
350	P0674350	SPACER (LONG)
351	P0674351	KNOB M8-1.25
352	P0674352	SPACER
353	PFH48M	FLAT HD SCR M8-1.25 X 18
354	P0674354	SPECIAL SCREW
355	P0674355	COVER PLATE
356	P0674356	FENCE CAP
357	P0674357	FLIP STOP ASSEMBLY
358	P0674358	WING KNOB
359	P0674359	FLIP STOP
360	P0674360	BUSHING
361	P0674361	INDICATOR
362	P0674362	SHAFT BRACKET



Electrical Components Breakdown



REF	PART #	DESCRIPTION
401	P0674401	JUNCTION BOARD
402	P0674402	TRANSFORMER TWC 602192/G
403	P0674403	FUSE 0.5A
404	P0674404	RELAY KB-04
405	P0674405	FUSE T16/250V
406	P0674406	CIRCUIT BOARD
407	P0674407	CONTACTOR KLIBO 7.5
408	P0674408	#2 STOP SWITCH
409	P0674409	#2 STOP SWITCH BOX
410	P0674410	CORD 2-WIRE
411	P0674411	CORD 6-WIRE
412	P0674412	FUSE HOLDER

REF	PART #	DESCRIPTION
413	P0674413	FUSE BOX
414	P0674414	CORD 7-WIRE
415	P0674415	POWER BOX
416	P0674416	ROTARY POWER SWITCH
417	P0674417	MAIN MOTOR CORD
418	P0674418	LIMIT SWITCH CORD
419	P0674419	LIMIT SWITCH
420	P0674420	SCORING MOTOR CORD
421	P0674421	CONTROL BOX
422	P0674422	STOP SWITCH
423	P0674423	MOTOR ON/OFF SWITCH



Labels Breakdown



REF	PART #	DESCRIPTION
501	P0674501	BLADE GUARD LABEL
502	P0674502	KICKBACK HAZARD LABEL
503	PLABEL-12A	READ MANUAL LABEL VL
504	PLABEL-57	GLASSES RESPIRATOR LABEL VL

REF	PART #	DESCRIPTION
505	P0674505	MACHINE ID LABEL
506	P0674506	MODEL NUMBER LABEL
507	G8589	GRIZZLY NAMEPLATE

⚠ WARNING

Safety labels warn about machine hazards and ways to prevent injury. The owner of this machine **MUST** maintain the original location and readability of the labels on the machine. If any label is removed or becomes unreadable, **REPLACE** that label before using the machine again. Contact Grizzly at (800) 523-4777 or www.grizzly.com to order new labels.





WARRANTY CARD

Name _____

Street _____

City _____ State _____ Zip _____

Phone # _____ Email _____ Invoice # _____

Model # _____ Order # _____ Serial # _____

The following information is given on a voluntary basis. It will be used for marketing purposes to help us develop better products and services. **Of course, all information is strictly confidential.**

1. How did you learn about us?

Advertisement
 Card Deck

Friend
 Website

Catalog
 Other:

2. Which of the following magazines do you subscribe to?

Cabinet Maker
 Family Handyman
 Hand Loader
 Handy
 Home Shop Machinist
 Journal of Light Cont.
 Live Steam
 Model Airplane News
 Modeltec
 Old House Journal

Popular Mechanics
 Popular Science
 Popular Woodworking
 Practical Homeowner
 Precision Shooter
 Projects in Metal
 RC Modeler
 Rifle
 Shop Notes
 Shotgun News

Today's Homeowner
 Wood
 Wooden Boat
 Woodshop News
 Woodsmith
 Woodwork
 Woodworker West
 Woodworker's Journal
 Other:

3. What is your annual household income?

\$20,000-\$29,000
 \$50,000-\$59,000

\$30,000-\$39,000
 \$60,000-\$69,000

\$40,000-\$49,000
 \$70,000+

4. What is your age group?

20-29
 50-59

30-39
 60-69

40-49
 70+

5. How long have you been a woodworker/metalworker?

0-2 Years

2-8 Years

8-20 Years

20+ Years

6. How many of your machines or tools are Grizzly?

0-2

3-5

6-9

10+

7. Do you think your machine represents a good value?

Yes

No

8. Would you recommend Grizzly Industrial to a friend?

Yes

No

9. Would you allow us to use your name as a reference for Grizzly customers in your area?

Note: We never use names more than 3 times.

Yes

No

10. Comments: _____

CUT ALONG DOTTED LINE

FOLD ALONG DOTTED LINE



Place
Stamp
Here



GRIZZLY INDUSTRIAL, INC.
P.O. BOX 2069
BELLINGHAM, WA 98227-2069



FOLD ALONG DOTTED LINE

Send a Grizzly Catalog to a friend:

Name _____
Street _____
City _____ State _____ Zip _____

TAPE ALONG EDGES--PLEASE DO NOT STAPLE

WARRANTY AND RETURNS

Grizzly Industrial, Inc. warrants every product it sells for a period of **1 year** to the original purchaser from the date of purchase. This warranty does not apply to defects due directly or indirectly to misuse, abuse, negligence, accidents, repairs or alterations or lack of maintenance. This is Grizzly's sole written warranty and any and all warranties that may be implied by law, including any merchantability or fitness, for any particular purpose, are hereby limited to the duration of this written warranty. We do not warrant or represent that the merchandise complies with the provisions of any law or acts unless the manufacturer so warrants. In no event shall Grizzly's liability under this warranty exceed the purchase price paid for the product and any legal actions brought against Grizzly shall be tried in the State of Washington, County of Whatcom.

We shall in no event be liable for death, injuries to persons or property or for incidental, contingent, special, or consequential damages arising from the use of our products.

To take advantage of this warranty, contact us by mail or phone and give us all the details. We will then issue you a "Return Number," which must be clearly posted on the outside as well as the inside of the carton. We will not accept any item back without this number. Proof of purchase must accompany the merchandise.

The manufacturers reserve the right to change specifications at any time because they constantly strive to achieve better quality equipment. We make every effort to ensure that our products meet high quality and durability standards and we hope you never need to use this warranty.

Please feel free to write or call us if you have any questions about the machine or the manual.

Thank you again for your business and continued support. We hope to serve you again soon.

grizzly.com

TOOL WEBSITE

Buy Direct and Save with Grizzly® – Trusted, Proven and a Great Value!

*Visit Our Website Today And Discover
Why Grizzly® Is The Industry Leader!*

- SECURE ORDERING
- ORDERS SHIPPED WITHIN 24 HOURS
- E-MAIL RESPONSE WITHIN ONE HOUR

-OR-

Call Today For A **FREE**
Full Color Catalog

1-800-523-4777



Free Manuals Download Website

<http://myh66.com>

<http://usermanuals.us>

<http://www.somanuals.com>

<http://www.4manuals.cc>

<http://www.manual-lib.com>

<http://www.404manual.com>

<http://www.luxmanual.com>

<http://aubethermostatmanual.com>

Golf course search by state

<http://golfingnear.com>

Email search by domain

<http://emailbydomain.com>

Auto manuals search

<http://auto.somanuals.com>

TV manuals search

<http://tv.somanuals.com>