

Grizzly **Industrial, Inc.**®

10" TABLE SAW MODEL G0444/G0444Z INSTRUCTION MANUAL

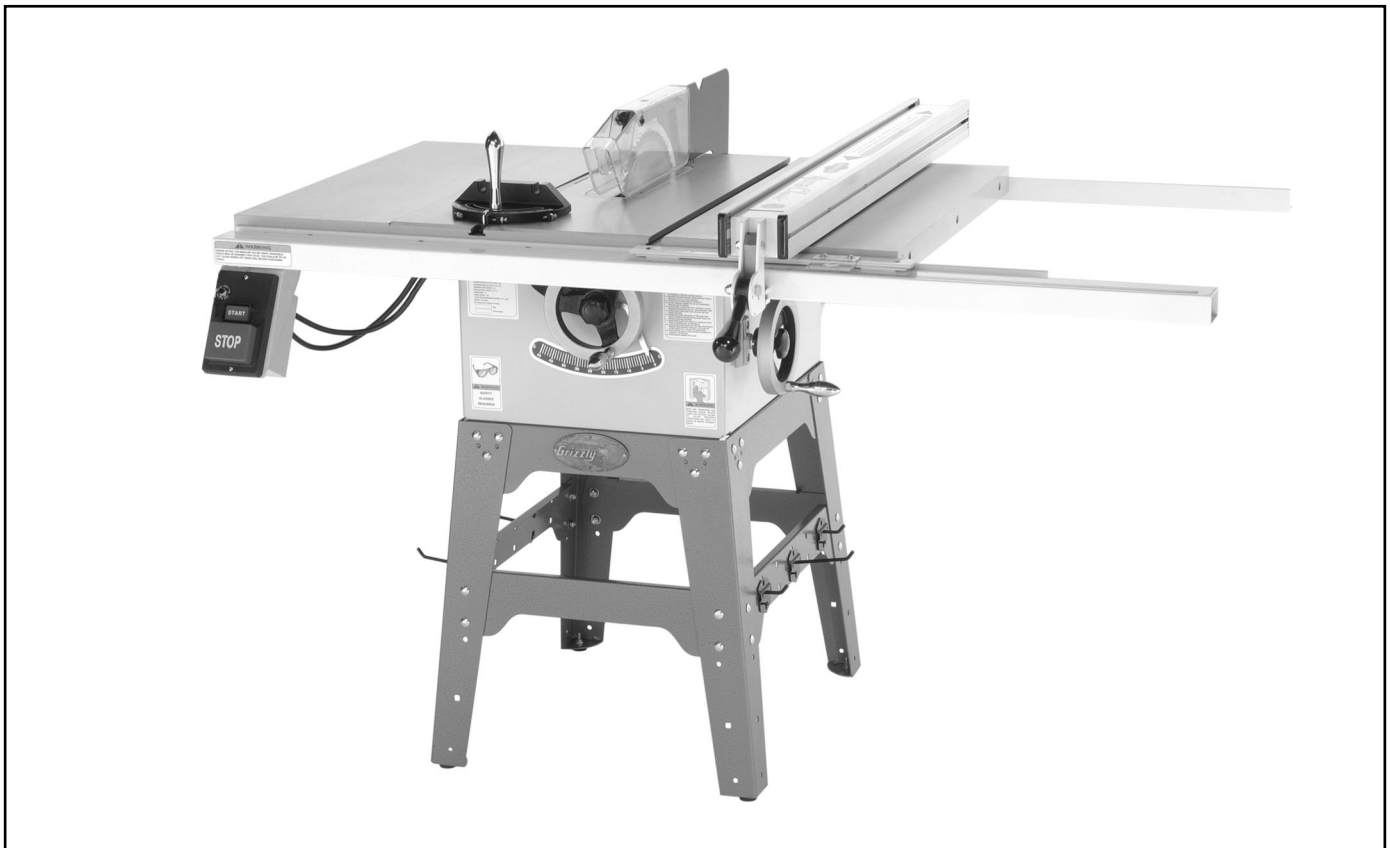

COPYRIGHT © OCTOBER 2003 BY GRIZZLY INDUSTRIAL, INC.

**WARNING: NO PORTION OF THIS MANUAL MAY BE REPRODUCED IN ANY SHAPE
OR FORM WITHOUT THE WRITTEN APPROVAL OF GRIZZLY INDUSTRIAL, INC.**

#5456 PRINTED IN TAIWAN

ONLINE MANUAL DISCLAIMER

THE INFORMATION IN THIS MANUAL REPRESENTS THE CONFIGURATION OF THE MACHINE AS IT IS CURRENTLY BEING SHIPPED. THE MACHINE CONFIGURATION CAN CHANGE AS PRODUCT IMPROVEMENTS ARE INCORPORATED. IF YOU OWN AN EARLIER VERSION OF THE MACHINE, THIS MANUAL MAY NOT EXACTLY DEPICT YOUR MACHINE. CONTACT CUSTOMER SERVICE IF YOU HAVE ANY QUESTIONS ABOUT DIFFERENCES. PREVIOUS VERSIONS ARE NOT AVAILABLE ONLINE.

WARNING

Some dust created by power sanding, sawing, grinding, drilling, and other construction activities contains chemicals known to the State of California to cause cancer, birth defects or other reproductive harm. Some examples of these chemicals are:

- Lead from lead-based paints.
- Crystalline silica from bricks, cement, and other masonry products.
- Arsenic and chromium from chemically treated lumber.

Your risk from these exposures varies, depending on how often you do this type of work. To reduce your exposure to these chemicals: work in a well ventilated area, and work with approved safety equipment, such as those dust masks that are specially designed to filter out microscopic particles.

Table Of Contents

SECTION 1: SAFETY	3
Safety Instructions For Power Tools	3
Additional Safety Instructions For Table Saws	5
Preventing Kickback.....	6
Protecting Yourself From Kickback	6
Safety Accessories.....	7
Common Definitions, Terms And Phrases.....	8
SECTION 2: INTRODUCTION	9
Commentary.....	9
SECTION 3: CIRCUIT REQUIREMENTS	10
Voltage & Amperage Draw	10
Circuit Breaker	10
Plug & Receptacle	10
Circuit Capacity	11
Grounding	11
Extension Cords.....	11
SECTION 4: MACHINE FEATURES	12
SECTION 5: SET UP	13
About this Section	13
Unpacking	13
Parts Inventory.....	13
Hardware Recognition Chart	16
Clean Up	17
Site Considerations	17
Beginning Assembly.....	18
Stand	18
Rubber Feet	19
Dust Port	20
Handwheels	20
Motor	21
Extension Wings	23
Blade	24
Fence	24
Switch.....	24
Miter Gauge	25
Blade Guard.....	25
Table Insert	27
Power Cord	28
Start Up	29
Recommended Adjustments	29
SECTION 6: OPERATIONS	30
General	30
Blade Selection	30
Crosscutting	32
Ripping.....	33
Dado Cutting	34
Rabbet Cutting	36
SECTION 7: MAINTENANCE	38
Cleaning	38
Lubrication	38
Miscellaneous	38
V-Belts	39
Bearings	39
Maintenance Log	40
SECTION 8: SERVICE ADJUSTMENTS	41
About Service.....	41
Blade Parallelism	41
45° & 90° Stops	44
Worm Gears.....	45

SECTION 9: REFERENCE INFO	46
General	46
Aftermarket Accessories	46
G0444 Machine Data Sheet.....	48
G0444Z Machine Data Sheet	49
Troubleshooting	55
Making A Push Stick	56
G0444 & G0444Z Wiring Diagrams	57
Warranty & Returns	58

SECTION 1: SAFETY

WARNING

For Your Own Safety Read Instruction Manual Before Operating This Equipment

The purpose of safety symbols is to attract your attention to possible hazardous conditions. This manual uses a series of symbols and signal words which are intended to convey the level of importance of the safety messages. The progression of symbols is described below. Remember that safety messages by themselves do not eliminate danger and are not a substitute for proper accident prevention measures.



Indicates an imminently hazardous situation which, if not avoided, WILL result in death or serious injury.



Indicates a potentially hazardous situation which, if not avoided, COULD result in death or serious injury.



Indicates a potentially hazardous situation which, if not avoided, MAY result in minor or moderate injury. It may also be used to alert against unsafe practices.

NOTICE

This symbol is used to alert the user to useful information about proper operation of the equipment.

WARNING

Safety Instructions For Power Tools

1. **KEEP GUARDS IN PLACE** and in working order.
2. **REMOVE ADJUSTING KEYS AND WRENCHES.** Form a habit of checking to see that keys and adjusting wrenches are removed from tool before turning on.
3. **KEEP WORK AREA CLEAN.** Cluttered areas and benches invite accidents.
4. **NEVER USE IN DANGEROUS ENVIRONMENT.** DO NOT use power tools in damp or wet locations, or where any flammable or noxious fumes may exist. Keep work area well lighted.
5. **KEEP CHILDREN AND VISITORS AWAY.** All children and visitors should be kept at a safe distance from work area.
6. **MAKE WORKSHOP CHILD PROOF** with padlocks, master switches, or by removing starter keys.
7. **NEVER FORCE TOOL.** It will do the job better and safer at the rate for which it was designed.
8. **USE RIGHT TOOL.** DO NOT force tool or attachment to do a job for which it was not designed.

WARNING

Safety Instructions For Power Tools

- 9. USE PROPER EXTENSION CORD.** Make sure your extension cord is in good condition. Conductor size should be in accordance with the chart below. The amperage rating should be listed on the motor or tool nameplate. An undersized cord will cause a drop in line voltage resulting in loss of power and overheating. Your extension cord must also contain a ground wire and plug pin. Always repair or replace extension cords if they become damaged.

Minimum Gauge for Extension Cords

AMP RATING	LENGTH		
	25ft	50ft	100ft
0-6	16	16	16
7-10	16	16	14
11-12	16	16	14
13-16	14	12	12
17-20	12	12	10
21-30	10	10	No

- 10. WEAR PROPER APPAREL.** DO NOT wear loose clothing, gloves, neckties, rings, bracelets, or other jewelry which may get caught in moving parts. Non-slip footwear is recommended. Wear protective hair covering to contain long hair.
- 11. ALWAYS USE SAFETY GLASSES.** Also use face or dust mask if cutting operation is dusty. Everyday eyeglasses only have impact resistant lenses, they are NOT safety glasses.
- 12. SECURE WORK.** Use clamps or a vise to hold work when practical. It's safer than using your hand and frees both hands to operate tool.
- 13. DO NOT OVER-REACH.** Keep proper footing and balance at all times.
- 14. MAINTAIN TOOLS WITH CARE.** Keep tools sharp and clean for best and safest performance. Follow instructions for lubricating and changing accessories.

- 15. USE RECOMMENDED ACCESSORIES.** Consult the owner's manual for recommended accessories. The use of improper accessories may cause risk of injury.

- 16. REDUCE THE RISK OF UNINTENTIONAL STARTING.** On machines with magnetic contact starting switches there is a risk of starting if the machine is bumped or jarred. Always disconnect from power source before adjusting or servicing. Make sure switch is in OFF position before reconnecting.

- 17. CHECK DAMAGED PARTS.** Before further use of the tool, a guard or other part that is damaged should be carefully checked to determine that it will operate properly and perform its intended function. Check for alignment of moving parts, binding of moving parts, breakage of parts, mounting, and any other conditions that may affect its operation. A guard or other part that is damaged should be properly repaired or replaced.

- 18. NEVER LEAVE TOOL RUNNING UNATTENDED. TURN POWER OFF.** DO NOT leave tool until it comes to a complete stop.

- 19. NEVER OPERATE A MACHINE WHEN TIRED, OR UNDER THE INFLUENCE OF DRUGS OR ALCOHOL.** Full mental alertness is required at all times when running a machine.

- 20. NEVER ALLOW UNSUPERVISED OR UNTRAINED PERSONNEL TO OPERATE THE MACHINE.** Make sure any instructions you give in regards to machine operation are approved, correct, safe, and clearly understood.

- 21. IF AT ANY TIME YOU ARE EXPERIENCING DIFFICULTIES** performing the intended operation, stop using the machine! Then contact our service department or ask a qualified expert how the operation should be performed.

WARNING

Additional Safety Instructions For Table Saws

- 1. BLADE GUARD.** Always use the blade guard on all "through-sawing" operations. *Through-sawing operations are those when the blade cuts completely through the workpiece.*
- 2. KICKBACK.** Be familiar with kickback. Kickback happens when the workpiece is thrown towards the operator at a high rate of speed. *Until you have a clear understanding of kickback and how it occurs, DO NOT operate this table saw!*
- 3. WORKPIECE CONTROL.** Make sure the workpiece is placed in a stable position on the table and is either supported by the rip fence or the crosscut table during cutting operations.
- 4. SAFETY ACCESSORIES.** Use featherboards, push sticks, hold-downs, and other safety devices to make cutting operations safe.
- 5. OPERATOR POSITION.** Never stand or have any part of your body directly in-line with the cutting path of the saw blade.
- 6. REACHING OVER SAW BLADE.** Never reach behind or over the blade with either hand while the saw is running. *If kickback occurs while reaching over the blade, hands or arms could be pulled into the spinning saw blade.*
- 7. USING RIP FENCE AND CROSSCUT FENCE TOGETHER.** When using the crosscut fence, the workpiece should never be contacting the rip fence while the saw blade is cutting.
- 8. STALLED BLADE.** Turn the saw off before attempting to "free" a stalled saw blade.
- 9. COMFORTABLE CUTTING OPERATIONS.** Avoid awkward operations and hand positions where a sudden slip could cause your hand to move into the spinning saw blade.
- 10. EXPERIENCING DIFFICULTIES.** If at any time you are experiencing difficulties performing the intended operation, stop using the machine! Contact our Service Department at (570) 546-9663.
- 11. BLADE HEIGHT.** Always adjust the blade to the proper height above the workpiece (when through-cutting).
- 12. DAMAGED SAW BLADES.** Never use blades that have been dropped or otherwise damaged; otherwise, serious personal injury could occur.
- 13. PUSH STICK.** Always use a push stick when ripping narrow stock.

WARNING

Like all machines there is danger associated with this machine. Accidents are frequently caused by lack of familiarity or failure to pay attention. Use this machine with respect and caution to lessen the possibility of operator injury. If normal safety precautions are overlooked or ignored, serious personal injury may occur.

CAUTION

No list of safety guidelines can be complete. Every shop environment is different. Always consider safety first, as it applies to your individual working conditions. Use this and other machinery with caution and respect. Failure to do so could result in serious personal injury, damage to equipment, or poor work results.

WARNING

Statistics prove that most common accidents among table saw users can be linked to kickback. Kickback is typically defined as the high-speed expulsion of stock from the table saw toward its operator. In addition to the danger of the operator or others in the area being struck by the flying stock, it is often the case that the operator's hands are pulled into the blade during the kickback.

Preventing Kickback

Below are tips to avoid the most common causes of kickback:

- Never attempt freehand cuts. If the workpiece is not fed perfectly parallel with the blade, a kickback will likely occur. Always use the rip fence or crosscut fence to support the workpiece.
- Make sure the blade splitter is always aligned with the blade. A misaligned blade splitter can cause the workpiece to bind or stop the flow of the cut, resulting in an increased chance of kickback. If you think that your blade splitter is not aligned with the blade, check it immediately!
- Ensure that your rip fence is parallel with the blade; otherwise, the chances of kickback are extreme. Take the time to check and adjust the rip fence.
- Use the blade splitter during every cut. The blade splitter maintains the kerf in the workpiece, therefore, reducing the chance of kickback.
- Feed cuts through to completion. Anytime you stop feeding a workpiece that is in the middle of a cut, the chance of binding, resulting in kickback, is greatly increased.



Protecting Yourself From Kickback

Even if you know how to prevent kickback, it may still happen. Here are some tips to protect yourself if kickback DOES occur:

- Stand to the side of the blade during every cut. If a kickback does occur, the thrown workpiece usually travels directly in front of the blade.
- Wear safety glasses or a face shield. In the event of a kickback, your eyes and face are the most vulnerable part of your body.
- Never, for any reason, place your hand behind the blade. Should kickback occur, your hand will be pulled into the blade.
- Use a push stick to keep your hands farther away from the moving blade. If a kickback occurs, the push stick will most likely take the damage that your hand would have received.



Safety Accessories

Push Sticks

The use of a push stick (**Figure 1**), particularly when cutting small or narrow workpieces, provides an added level of safety for the operator. See the template at the end of the manual for construction details, or purchase one from the Grizzly catalog.

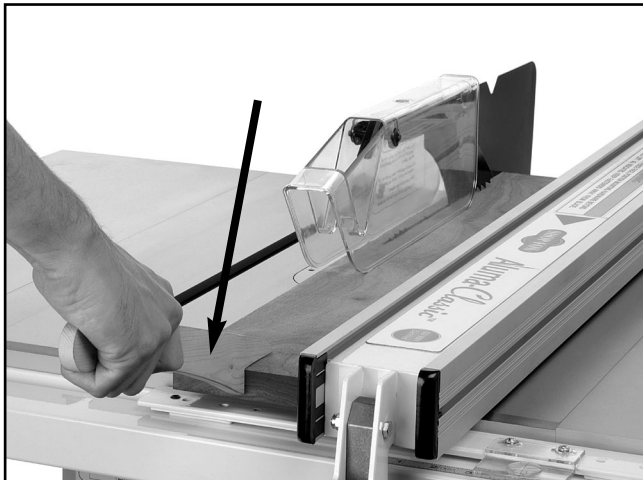

Figure 1. Push stick in use.

Zero Clearance Table Inserts

Ideal for use when ripping thin strips or making bevel cuts, zero clearance table inserts reduce workpiece tearout and prevent cut-off pieces from getting jammed between the blade and the table. See **Figure 2** for examples of zero clearance table inserts.

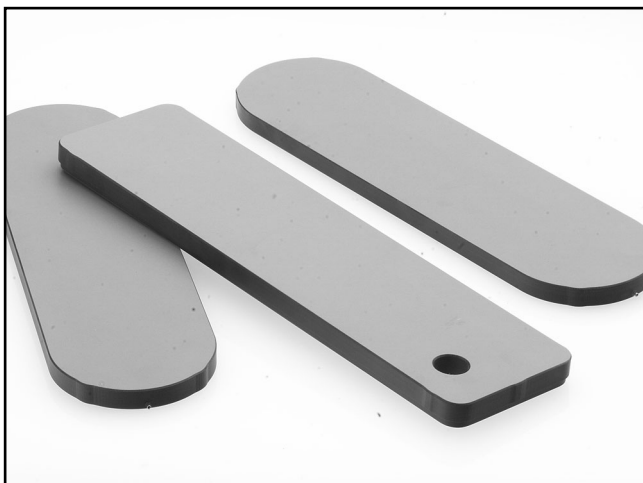

Figure 2. Zero clearance table inserts.

Featherboards

Featherboards (**Figure 3**) help prevent workpiece kickback. To make a featherboard, cut a 30-40° angle at one end of the board, and make a number of end cuts at approximately 1/4" apart and 2" to 3" deep.



Figure 3. Featherboards.



Common Definitions, Terms And Phrases

Arbor: Metal shaft that connects the drive mechanism to the blade.

Bevel Edge Cut: Tilting the saw arbor and blade to an angle between 0° and 45° to perform an angled cutting operation.

Blade Guard: Guard mechanism that mounts over the saw blade to prevent accidental contact with the cutting edge.

Crosscut: Table saw operation in which the miter gauge is used to cut across the grain of the workpiece.

Dado Blade: Blade or set of blades that attach to the arbor and are used for cutting grooves and rabbets.

Dado Cut: Table saw operation that uses a dado blade to cut a flat bottomed groove into the face of the workpiece.

Featherboard: Safety device used to keep a board against the rip fence or table. Allows operator to keep hands away from the saw blade.

Kerf: The resulting cut or gap made by a saw blade.

Kickback: An event in which the workpiece is thrown back toward an operator at a high rate of speed.

Miter Gauge: A component that controls the workpiece movement while performing a crosscut. Allows for variation of angle cuts such as miter cuts used on a picture frame.

Moulding Head: A cutterhead attached to the arbor. Accepts interchangeable moulding knives for profile cutting. We DO NOT recommend the use of moulding heads because they require advanced skills for their safe operation.

Non-Through Cut: A sawing operation that requires the removal of the blade guard and splitter. Dado and rabbet cuts are considered

Non-Through Cuts because the blade does not protrude above the top face of the workpiece. Always remember to re-install the blade guard and splitter after performing a non-through cut.

Parallel: Being an equal distance apart at every point. i.e. the rip fence face is parallel to the side face of the saw blade.

Perpendicular: Intersecting and forming right angles; at right angles to the vertical and horizontal planes. i.e. at 90° the blade is perpendicular to the table surface.

Push Paddle/Push Stick: Safety aid used to push the workpiece through the cutting operation.

Rabbet: Cutting operation that creates an L-shaped channel along the edge of the board.

Rip Cut: A cut made along the grain of the workpiece.

Sacrificial Fence: A piece of wood attached to the face of the rip fence that is designed to extend the fence face away from the metal portion of the fence. Used primarily when making rabbet cuts with a dado blade.

Splitter: Metal plate attached to the back of the blade guard that maintains the kerf opening in the workpiece when performing a cutting operation.

Standard Kerf: 1/8" gap made with a standard blade.

Straightedge: A tool used to check the flatness, parallelism, or consistency of a surface(s).

Thin Kerf: 3/32" gap made with a thin kerf blade.

Through Cut: A sawing operation in which the workpiece thickness is completely sawn through. Proper blade height usually allows 1/4" of the top of the blade to extend above the wood stock.

SECTION 2: INTRODUCTION

Commentary

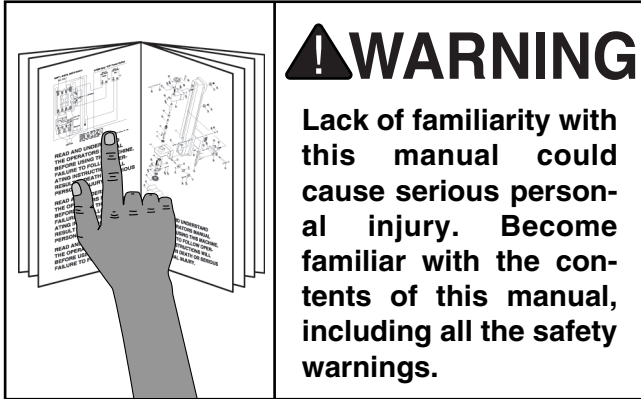

We are proud to offer the Model G0444/G0444Z 10" Table Saw. This machine is part of a growing Grizzly family of fine woodworking machinery. When used according to the guidelines set forth in this manual, you can expect years of trouble-free, enjoyable operation and proof of Grizzly's commitment to customer satisfaction.

We are pleased to provide this manual with the Model G0444/G0444Z. It was written to guide you through assembly, review safety considerations, and cover general operating procedures. It represents our effort to produce the best documentation possible. If you have any comments regarding this manual, please write to us at the address below:

Grizzly Industrial, Inc.
% Technical Documentation
P.O. Box 2069
Bellingham, WA 98227-2069

Most importantly, we stand behind our machines. If you have any service questions or parts requests, please call or write us at the location listed below.

Grizzly Industrial, Inc.
1203 Lycoming Mall Circle
Muncy, PA 17756
Phone: (570) 546-9663
Fax: (800) 438-5901
E-Mail: techsupport@grizzly.com
Web Site: <http://www.grizzly.com>

The specifications, drawings, and photographs illustrated in this manual represent the Model G0444/G0444Z as supplied when the manual was prepared. However, owing to Grizzly's policy of continuous improvement, changes may be made at any time with no obligation on the part of Grizzly. For your convenience, we always keep current Grizzly manuals available on our website at www.grizzly.com. Any updates to your machine will be reflected in these manuals as soon as they are complete. Visit our site often to check for the latest updates to this manual!



SECTION 3: CIRCUIT REQUIREMENTS

Voltage & Amperage Draw

The following list outlines the voltage required to operate the saws, as well as the amperage draw of their motors:

G0444	
110V (prewired)	18 Amps
220V	9 Amps

G0444Z	
110V	24 Amps
220V (prewired)	12 Amps



Circuit Breaker

Use the following guidelines when choosing a circuit breaker (circuit breakers rated any higher are not adequate to protect the circuit):

G0444	
110V (prewired)	20 Amp, 1 Pole
220V	10 Amp, 2 Pole

G0444Z	
110V	25 Amp, 1 Pole
220V (prewired)	15 Amp, 2 Pole



Plug & Receptacle

The following list and figures outline the correct plug and receptacle to use:

G0444	
110V (prewired)	NEMA 5-15
220V	NEMA 6-15*
<i>*Not Included</i>	

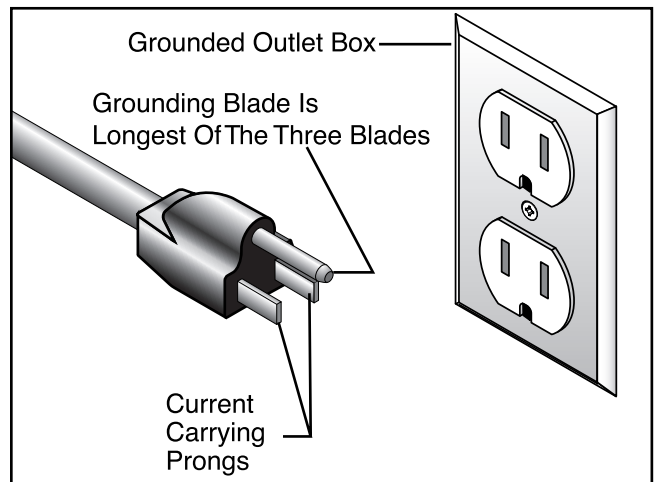

Figure 4. NEMA 5-15 plug and receptacle.

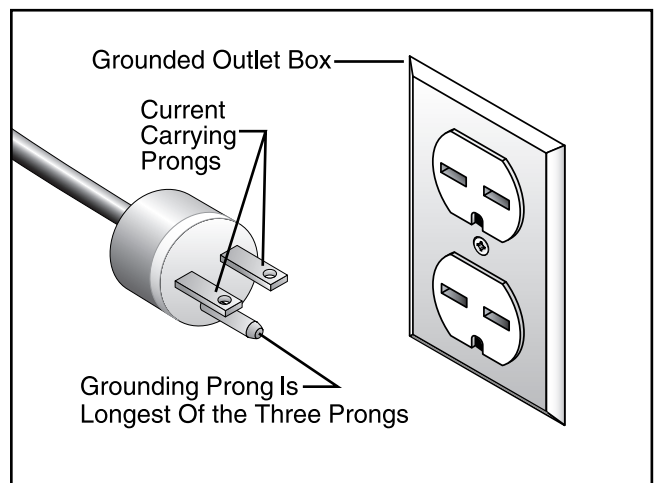

Figure 5. NEMA 6-15 plug and receptacle.

G0444Z

110V..... NEMA 5-30*

220V (prewired) NEMA 6-15*

*Not Included

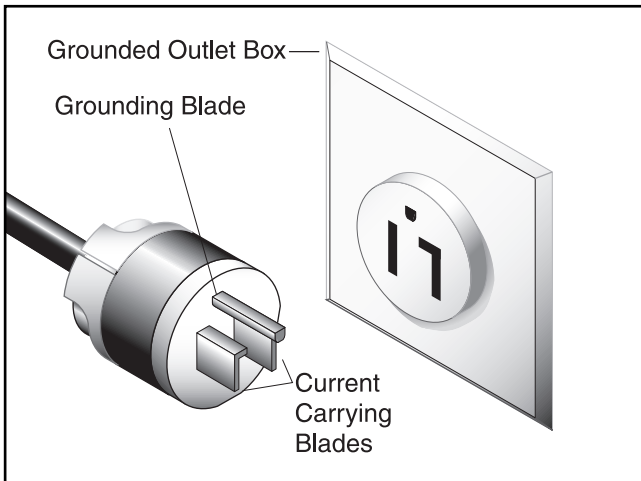

Figure 6. NEMA 5-30 plug and receptacle.

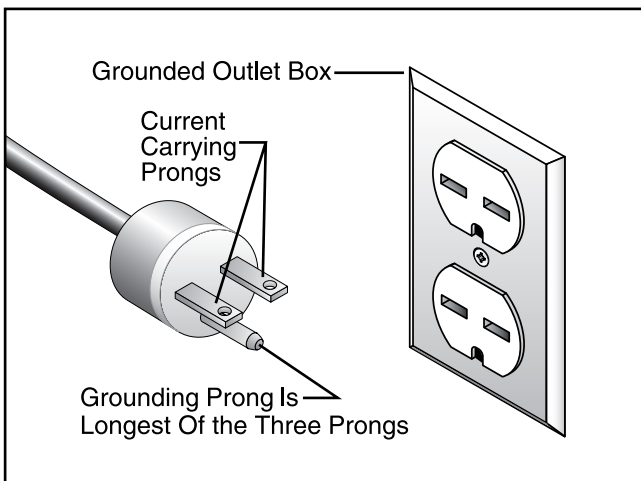

Figure 7. NEMA 6-15 plug and receptacle.



Circuit Capacity

Always check to see if the wires in your circuit are capable of handling the amperage draw from your machine, as well as any other machines that could be operating on the same circuit. If you are unsure, consult a qualified electrician.

If the circuit breaker trips or the fuse blows regularly, your machine may be operating on a circuit that is close to its amperage draw capacity. However, if an unusual amperage draw does not exist and a power failure still occurs, contact a qualified electrician.



Grounding

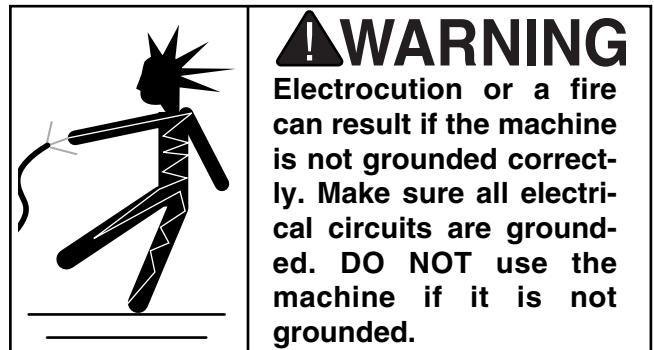

NOTICE

The wire on the power cord with green or green and yellow striped insulation is the grounding conductor.

In the event of an electrical short, grounding reduces the risk of electric shock by providing a path of least resistance to disperse electric current. This tool is equipped with a power cord that has an equipment-grounding prong. The outlet must be properly installed and grounded in accordance with all local codes and ordinances.



Extension Cords

Because of the high amperage draw from this machine, we do not recommend the use of extension cords. Instead, position machines near installed wiring to eliminate the need for extension cords.



SECTION 4: MACHINE FEATURES

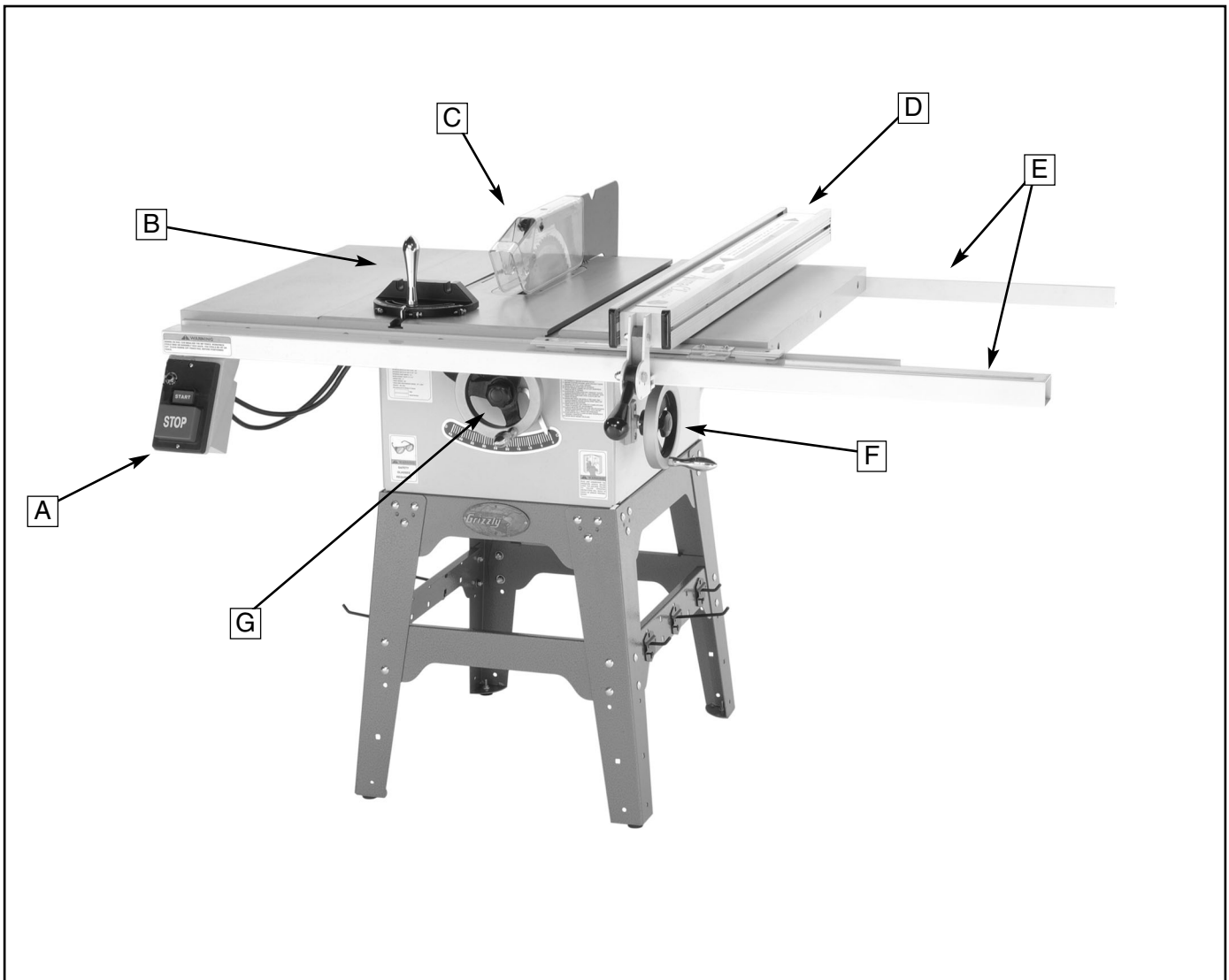

Figure 8. Front view.

- A. Power Switch
- B. Miter Gauge
- C. Blade Guard
- D. Rip Fence
- E. Fence Rails
- F. Blade Tilt Handwheel
- G. Blade Height Handwheel

SECTION 5: SET UP

About this Section

The purpose of this section is to guide you through the required steps to get your machine out of its packaging and into operating condition.

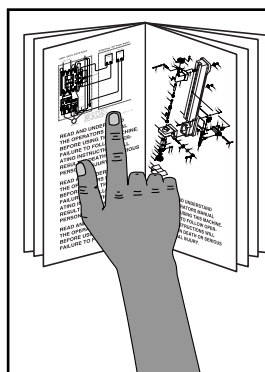

! WARNING
This machine presents serious injury hazards to untrained users. Read through this entire manual to become familiar with the controls and operations before starting the machine!



! WARNING
Wear safety glasses during the entire set up process!



Unpacking

The Model G0444/G0444Z is shipped from the manufacturer in carefully packed boxes. If you discover the machine is damaged after you have signed for delivery, *please immediately call Customer Service at (570) 546-9663 for advice.*

Save the containers and all packing materials for possible inspection by the carrier or its agent. *Otherwise, filing a freight claim can be difficult.*

When you are completely satisfied with the condition of your shipment, you should inventory the parts.



G0444/G0444Z 10" Table Saw

Parts Inventory

DESCRIPTION	QTY
Hand Tool Hardware Bag:	
• Combo Wrench 12 x 13	1
• Arbor Wrench 23mm	1
• Hex Key 2mm	1
• Hex Key 3mm	1
• Hex Key 4mm	1
Rubber Feet Hardware Bag:	
• Rubber Feet	4
• Phillips Head Screws 1/4"-20 x 1"	4
• Hex Nuts 1/4"-20	4
• Flat Washers 1/4"	4
Stand Hardware Bag:	
• Hex Bolts 5/16"-18 x 1"	4
• Hex Nuts 5/16"-18	44
• Flat Washers 5/16"	48
• Carriage Bolts 5/16"-18 x 5/8"	40
• Lock Washers 5/16"	44
Motor Mounting Hardware Bag:	
• Hex Bolts 5/16"-18 x 1"	4
• Hex Nuts 5/16"-18	4
• Flat Washers 5/16"	8
• Lock Washers 5/16"	4
• Flat Washer 1/4"	1
• Carriage Bolt 1/4"-20 x 1 3/4"	1
• Brass Wing Nut 1/4"-20	1
• Fiber Washer 5/16"	1
• Speed Nut 1/4"	1
Blade Guard Hardware Bag:	
• Blade Guard	1
• Blade Guard Mounting Bracket Assembly ..	1
• Blade Guard Mounting Shaft	1
• Hex Nut 1/2"-12	1
• Flat Washer 1/2"	1
Extension Wing Hardware Bag:	
• Hex Bolts 7/16"-14 x 1 1/4"	6
• Lock Washers 7/16"	6
Dust Hood Hardware Bag:	
• Phillips Head Screws #10-24 x 5/8"	2
• Hex Nuts #10-24	2
• Star Washers #10	2
• Toggle Tabs	2

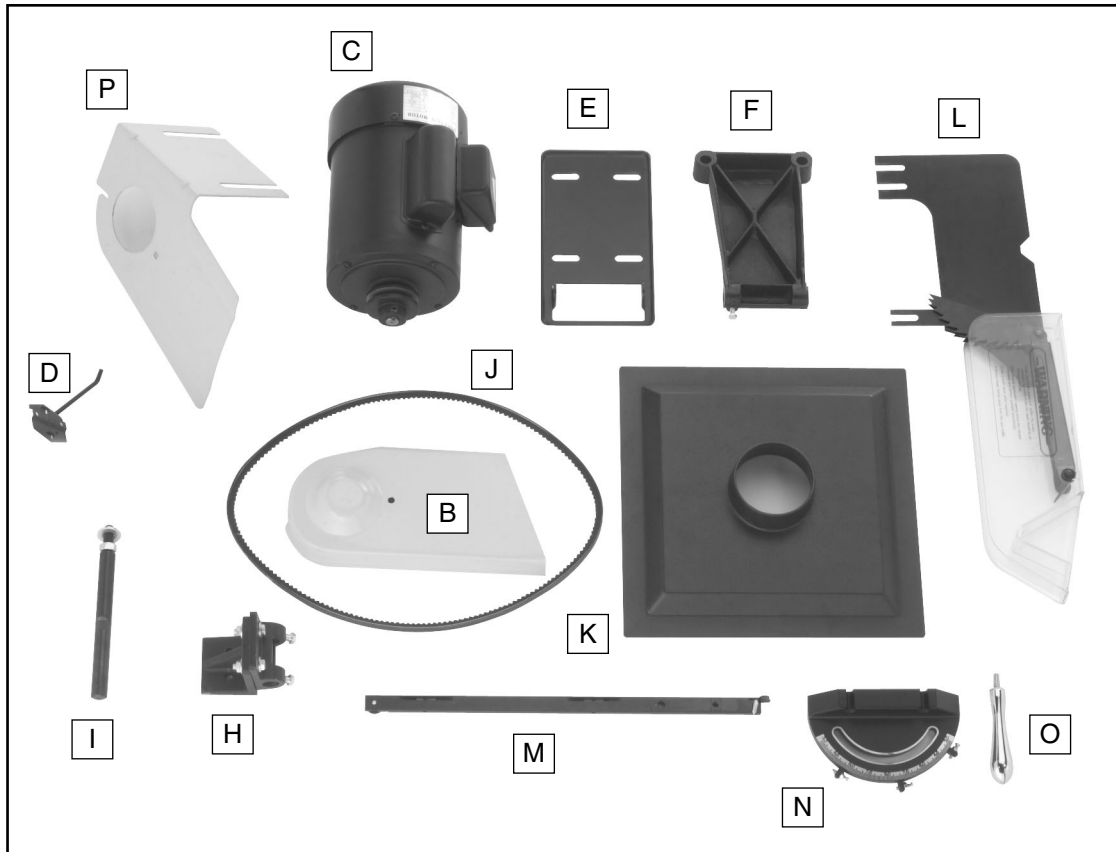

Figure 9. Parts layout.

DESCRIPTION	QTY
A. Table Saw Unit (Not Shown)	1
B. V-Belt Guard.....	1
C. Motor	1
D. Stand Accessory Hanger Package.....	1
E. Motor Plate	1
F. Motor Bracket	1
G. Motor Pivot Shaft (Not Shown).....	1
H. Blade Guard Mounting Bracket*	1
I. Blade Guard Mounting Shaft*	1
J. V-Belt	1
K. Dust Hood.....	1
L. Blade Guard*	1
M. Miter Gauge Bar	1
N. Miter Gauge Body	1
O. Miter Gauge Handle	1
P. V-Belt Plate.....	1

**Located in the Blade Guard Hardware Bag*

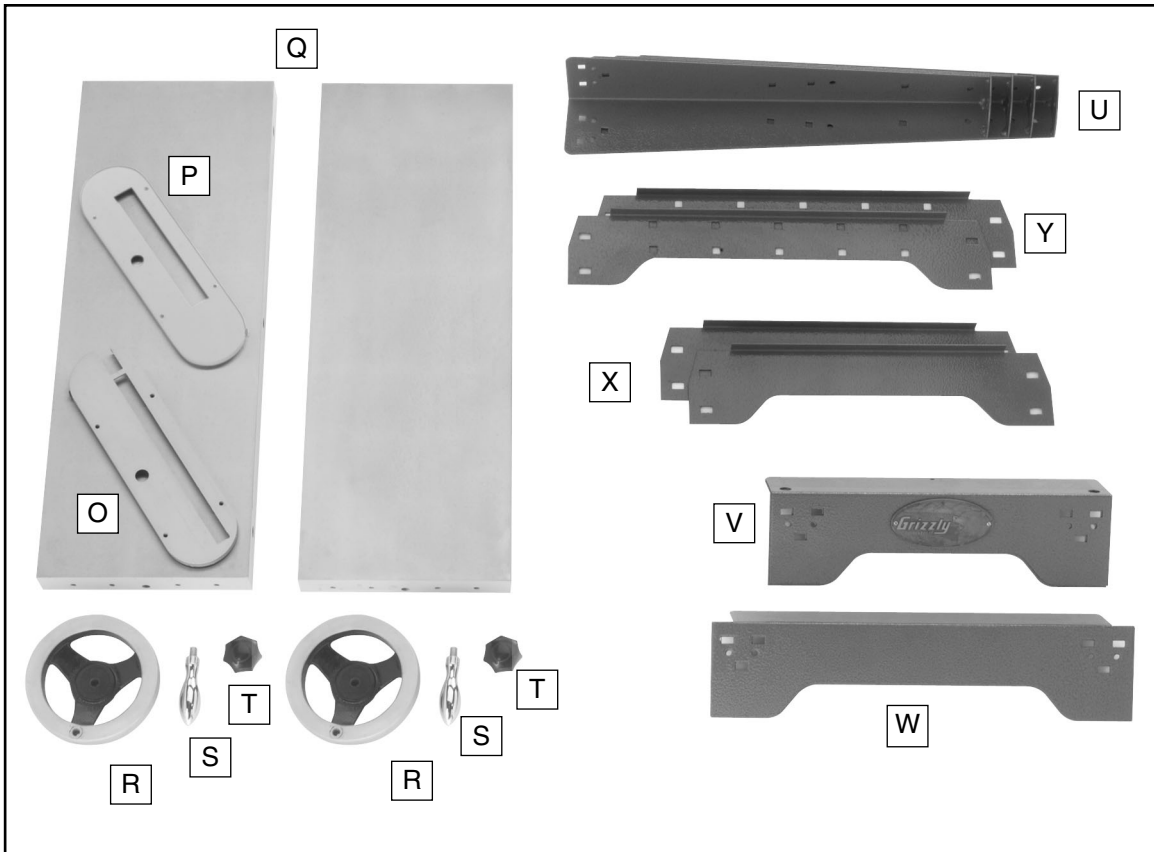

Figure 10. Parts layout.

DESCRIPTION	QTY
O. Table Insert - Standard	1
P. Table Insert - Dado	1
Q. Cast Iron Extension Wings (G0444Z)	2
R. Handwheels	2
S. Threaded Handles $\frac{3}{8}$ "-16 x $\frac{1}{2}$ "	2
T. Star Knobs $\frac{3}{8}$ "-16.....	2
U. Stand Legs.....	4
V. Top Short Bracket	2
W. Top Long Bracket.....	2
X. Bottom Short Bracket.....	2
Y. Bottom Long Bracket	2
Z. Switch (Not Shown)	1

Hardware Recognition Chart

USE THIS CHART TO MATCH UP
HARDWARE DURING THE ASSEMBLY
PROCESS!

MEASURE BOLT DIAMETER BY PLACING INSIDE CIRCLE

- #10
- 1/4"
- 5/16"
- 3/8"
- 7/16"
- 1/2"
- 5/8"
- 4mm
- 6mm
- 8mm
- 10mm
- 12mm
- 16mm

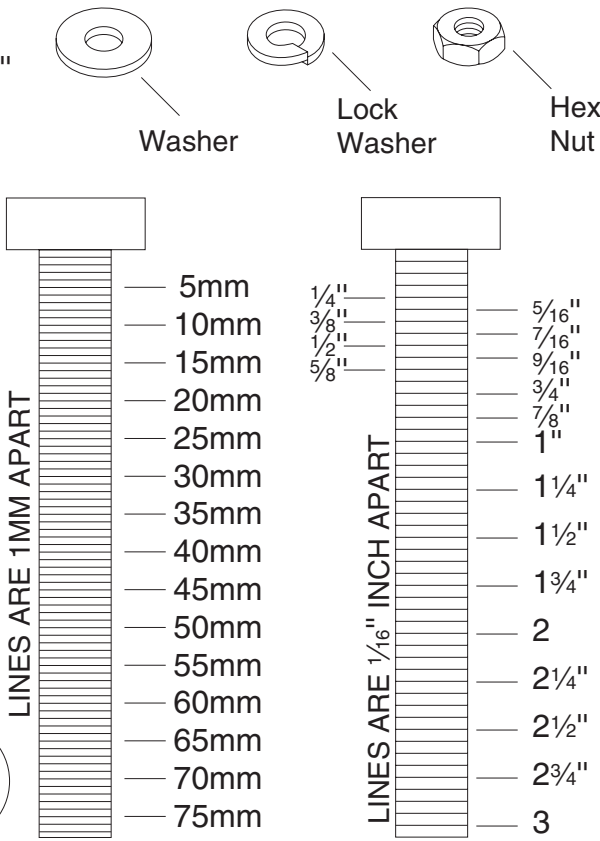
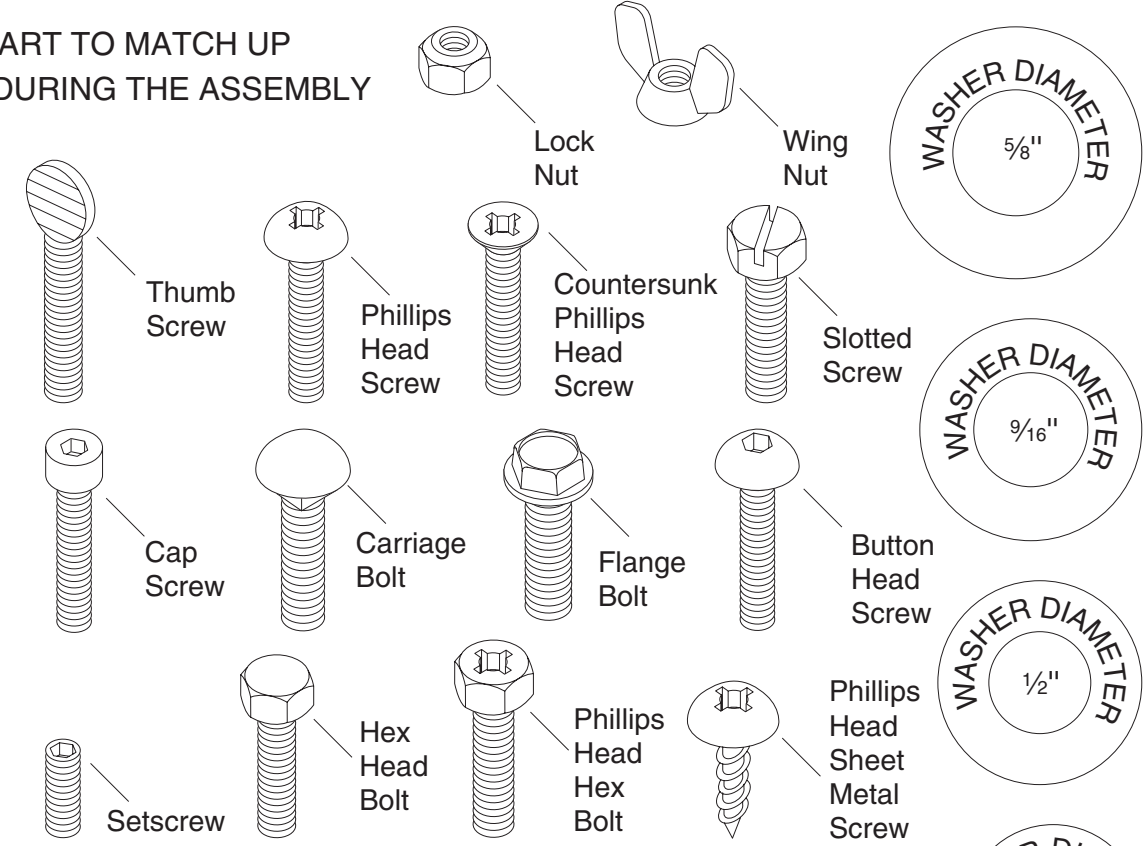

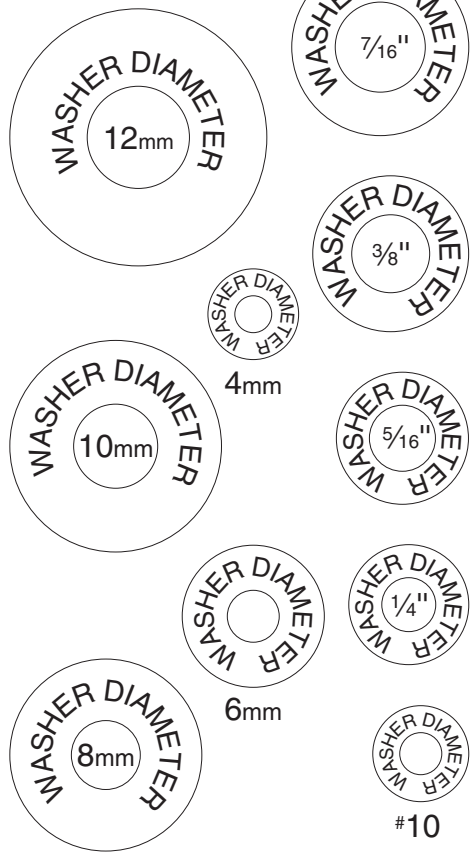

WASHERS ARE MEASURED BY THE INSIDE DIAMETER



Clean Up

The unpainted surfaces are coated with a waxy oil to protect them from corrosion during shipment. Remove this protective coating with a solvent cleaner or citrus-based degreaser such as Grizzly's G7895 Degreaser. To clean thoroughly, some parts may need to be removed. **For optimum performance from your machine, make sure you clean all moving parts or sliding contact surfaces that are coated.** Avoid chlorine-based solvents as they may damage painted surfaces should they come in contact.

	<p>!WARNING Gasoline and petroleum products have low flash points and could explode if used to clean machinery. DO NOT use gasoline or petroleum products to clean the machinery.</p>
--	---

	<p>!WARNING Smoking near solvents could ignite an explosion or fire and cause serious injury. DO NOT smoke while using solvents.</p>
---	--

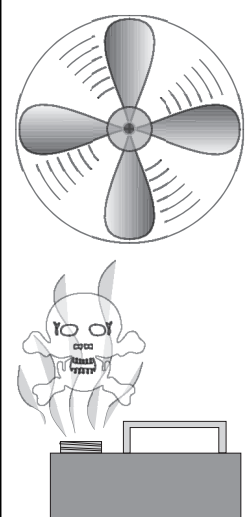
	<p>!WARNING Lack of ventilation while using solvents could cause serious personal health risks, fire, or environmental hazards. Always work in a well ventilated area to prevent the accumulation of dangerous fumes. Supply the work area with a constant source of fresh air.</p>
---	--



Site Considerations

Floor Load

The Model G0444 weighs 257 lbs. and the Model G0444Z weighs 283 lbs. Both models have a base footprint of 21"W x 26"D. Most commercial floors are suitable for your machine. Some residential floors may require additional reinforcement to support both the machine and operator.

Working Clearances

Consider existing and anticipated needs, size of material to be processed through each machine, and space for auxiliary stands, work tables or other machinery when establishing a location for your saw. See **Figure 11** for the maximum working clearances of the Model G0444/G0444Z.

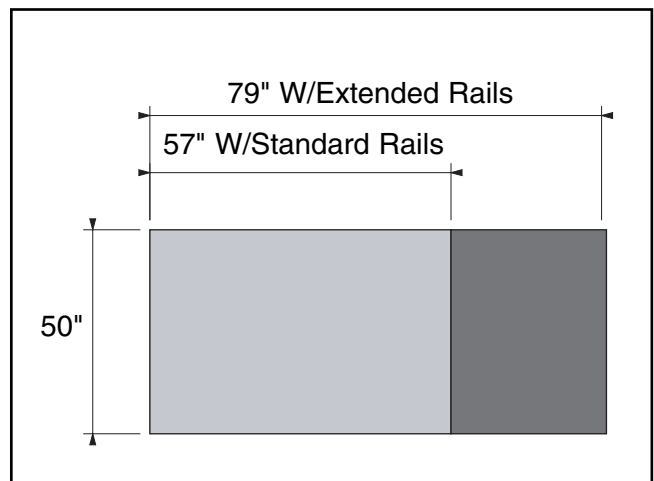
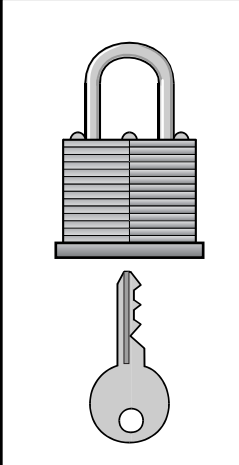

Figure 11. Maximum working clearance.

	<p>!WARNING Unsupervised children and visitors inside your shop could receive serious personal injury. Ensure child and visitor safety by keeping all entrances to the shop locked at all times. DO NOT allow unsupervised children or visitors in the shop at any time.</p>
--	--





Beginning Assembly

This section will cover the basic assembly and adjustment instructions needed to begin operation. Complete the assembly in the order provided in this manual and then read the remaining portion of the manual before attempting any type of operation.

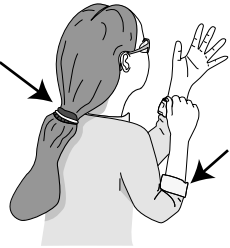
Your safety is important! Please follow the warnings below during this entire section:

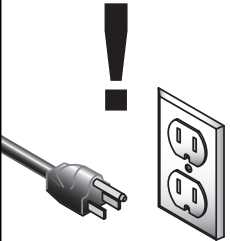
	<p>⚠ WARNING Loose hair and clothing could get caught in machinery and cause serious personal injury. Keep loose clothing rolled up and long hair tied up and away from machinery.</p>
---	---

	<p>⚠ WARNING Disconnect power to the machine during the entire assembly process. Failure to do this may result in serious personal injury.</p>
---	---

	<p>⚠ CAUTION Sharp edges on metal parts may cause personal injury. Examine the edges of all metal parts before handling.</p>
---	---



Stand

Components and Hardware Needed:	Qty
Saw	1
Stand Legs	4
Side Supports	
• Long Flat	2
• Long Short	2
• Long "L"	2
• Short "L"	2
Carriage Bolts $\frac{5}{16}$ "-18 x $\frac{5}{8}$ "	40
Hex Bolts $\frac{5}{16}$ "-18 x 1	4
Hex Nuts $\frac{5}{16}$ "-18	44
Flat Washers $\frac{5}{16}$ "	48
Lock Washers $\frac{5}{16}$ "	44

Tools Needed:
 12mm Wrench or Socket.....1

<h2>NOTICE</h2> <p>Do not final tighten the stand bolts until all the stand components have been assembled and the saw is rightside-up.</p>
--

To assemble the stand:

1. With the help of an assistant, place the saw face-down on the floor. Note—*Lay clean and staple-free cardboard down to protect the table surface.*
2. Place the short "L" side supports on the bottom of the saw body (**Figure 12**). Note—*Make sure the cast logo is facing the front of the machine.*

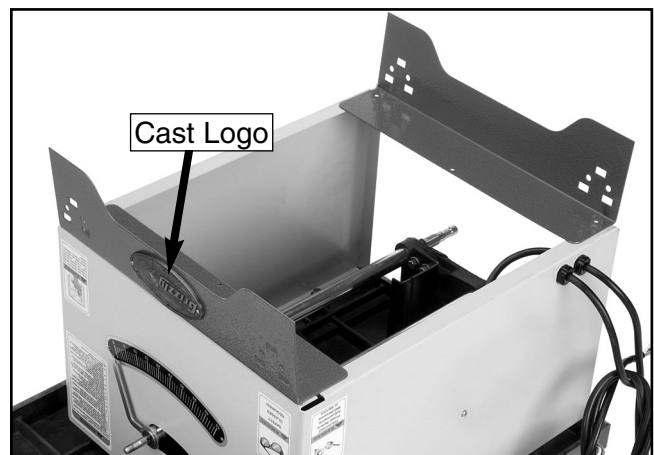

Figure 12. L side support installation.

G0444/G0444Z 10" Table Saw

3. Place the long "L" side supports over the ends of the short "L" side supports.
4. Using a 12mm wrench, secure all four "L" side supports to the saw body with 4 hex bolts, 8 flat washers, 4 lock washers, and 4 hex nuts.
5. Secure each stand leg to the outside of the "L" side supports with 24 carriage bolts, 24 flat washers, 24 lock washers, and 24 hex nuts (**Figure 13**).

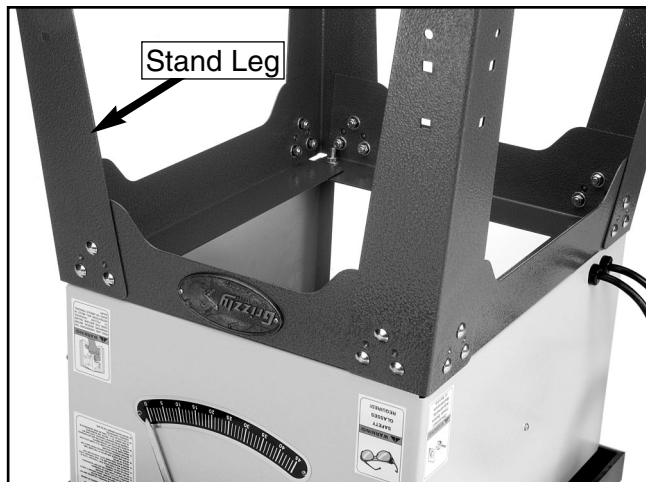

Figure 13. Stand leg installation.

6. Secure the flat side supports to the stand legs with 16 carriage bolts, 16 flat washers, 16 lock washers, and 16 hex nuts (**Figure 12**).

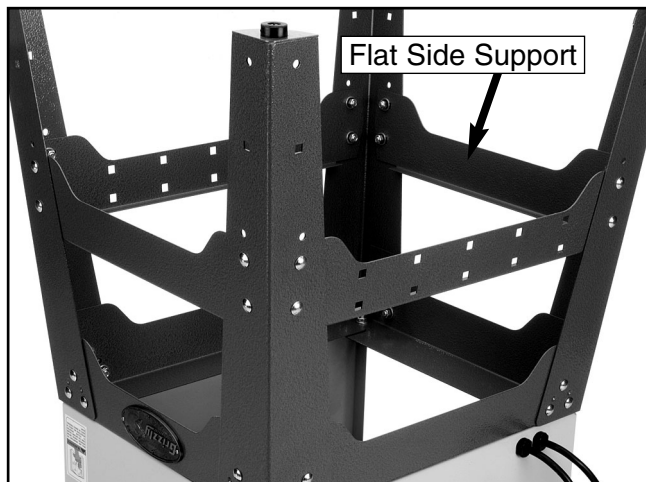

Figure 14. Flat side support installation.

Rubber Feet

Components and Hardware Needed:	Qty
Rubber Feet.....	4
Hex Nuts 1/4"-20	4
Flat Washers 1/4"	4
Phillips Head Screws 1/4"-20 x 1"	4

Tools Needed:

10mm Wrench or Socket.....	1
Phillips Head Screwdriver	1

To install the rubber feet:

1. Using a 10mm wrench and a Phillips head screwdriver, secure each rubber foot to the stand legs with the Phillips head screws, the hex nuts, and the flat washers (**Figure 15**).

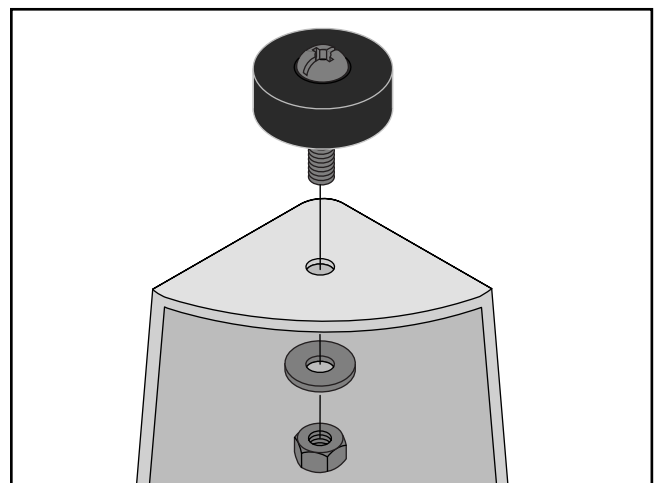

Figure 15. Rubber feet installation.

2. With the help of an assistant, flip the stand rightside up.
3. Final tighten all of the stand fasteners.



Dust Port

Components and Hardware Needed:	Qty
Dust Port	1
Phillips Head Screws #10-24 x $\frac{5}{8}$ "	2
Hex Nuts #10-24	2
Exterior Tooth Washers #10	2
Toggle Tabs.....	2

Tools Needed:

8mm Wrench or Socket.....	1
Phillips Head Screwdriver	1

To install the dust port:

1. Place the dust port in the opening at the base of the saw.
2. Using a Phillips head screwdriver and an 8mm wrench, secure the dust port to the saw with the Phillips head screws, the hex nuts, the exterior tooth washers, and the toggle tabs (**Figure 16**).

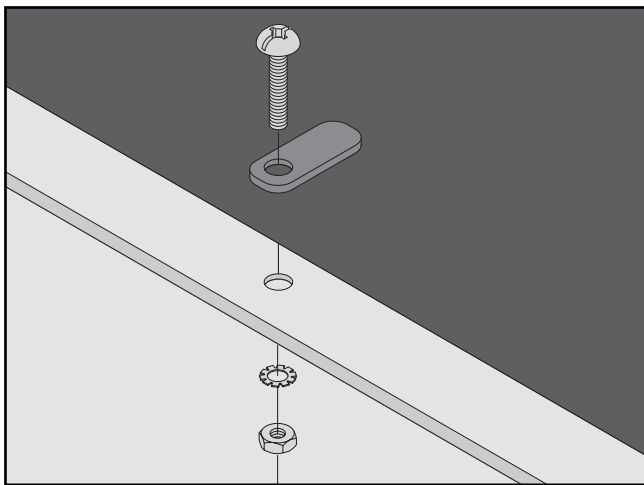

Figure 16. Dust port installation.



Handwheels

Components and Hardware Needed:	Qty
Handwheels.....	2
Threaded Chrome Handles $\frac{3}{8}$ "-16 x $\frac{1}{2}$ "	2
Star Knobs $\frac{3}{8}$ "-16	2

Tools Needed:

14mm Wrench or Socket.....	1
----------------------------	---

To install the handwheels:

1. Thread a chrome handle into each handwheel.
2. Using a 14mm wrench, final tighten the handles on each handwheel.
3. Slide each handwheel over the threaded shafts that protrude from the side and front of the saw (**Figure 17**). Note—Align the keyway on the back of each handwheel with the roll pin on the threaded shafts.

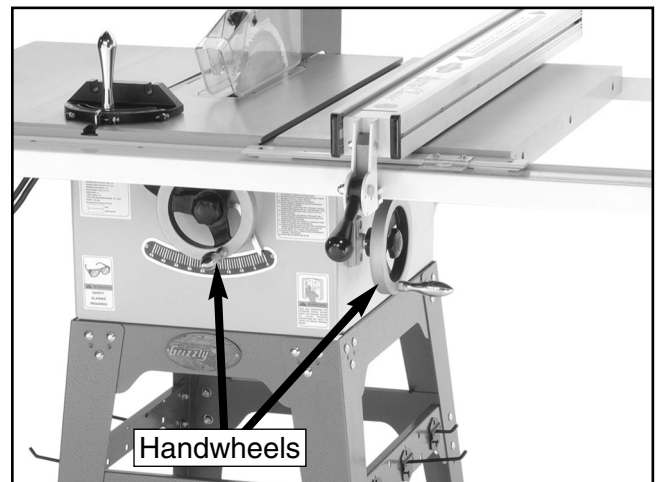

Figure 17. Installed handwheel.

4. Secure the handwheels to the threaded shaft with the star knobs (**Figure 17**).
5. Using the blade tilt handwheel, adjust the trunnion assembly until the bevel scale reads 90° .



Motor

Components and Hardware Needed:	Qty
Motor	1
Motor Plate	1
Motor Bracket	1
Motor Bracket Shaft.....	1
V-Belt Plate	1
V-Belt Guard	1
Hex Bolts $\frac{5}{16}$ "-18 x 1	4
Hex Nuts $\frac{5}{16}$ "-18	4
Flat Washers $\frac{5}{16}$ "	8
Lock Washers $\frac{5}{16}$ "	4
Carriage Bolt $\frac{1}{4}$ "-20 x $1\frac{3}{4}$ "	1
Brass Wing Nut $\frac{1}{4}$ "-20	1
Speed Nut $\frac{1}{4}$ "	1

Tools Needed:

12mm Wrench or Socket.....	1
10mm Wrench or Socket.....	1
4mm Allen Wrench	1

To install the motor:

- Using a 12mm wrench, loosely secure the motor to the motor plate with the hex bolts, the lock washers, the flat washers, and the hex nuts (**Figure 18**).

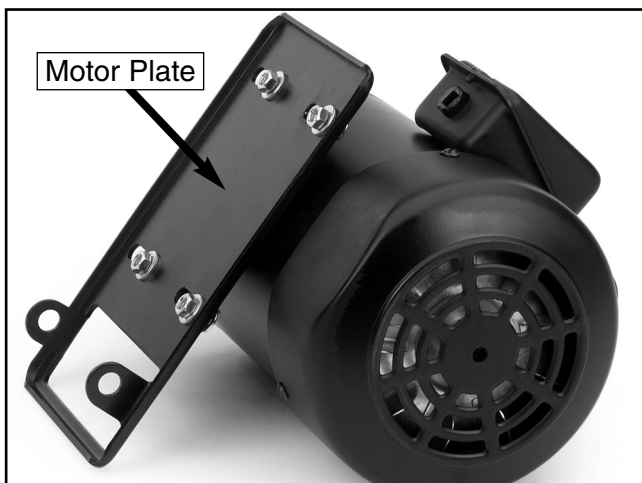

Figure 18. Installed motor plate.

- Slide the carriage bolt through the hole in the V-belt plate and slide the speed nut over the carriage bolt end.
- Slide the v-belt plate between the motor and the motor plate and over the hex bolts (**Figure 19**).

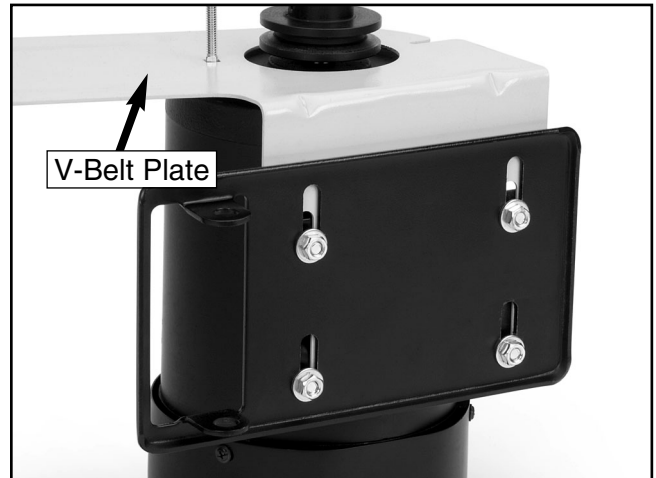

Figure 19. Installed V-belt plate.

- Finger tighten the fasteners that secure the motor to the motor plate.
- Secure the motor plate to the motor bracket with the motor bracket shaft (**Figure 20**). Note—*The hex bolt on the motor bracket must align with the groove on the motor bracket shaft.*

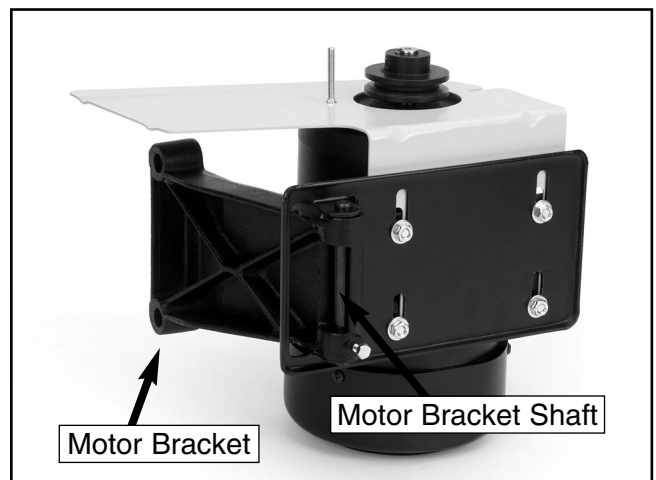

Figure 20. Installed motor bracket.

6. Tighten the hex nut on the motor bracket to secure the motor bracket shaft into place.
7. Slide the motor assembly onto the two shafts protruding from the back of the saw (**Figure 21**).

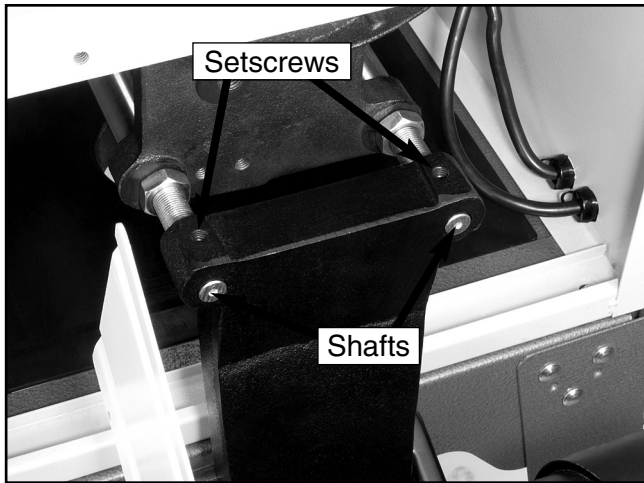

Figure 21. Installed motor assembly.

8. Using a 4mm Allen wrench, tighten the two setscrews (**Figure 21**) in the motor bracket to secure the motor assembly to the shafts.
9. Raise the motor assembly and slip the V-belt over the motor and arbor pulleys (**Figure 22**). Lower the motor assembly to tension the V-belt.

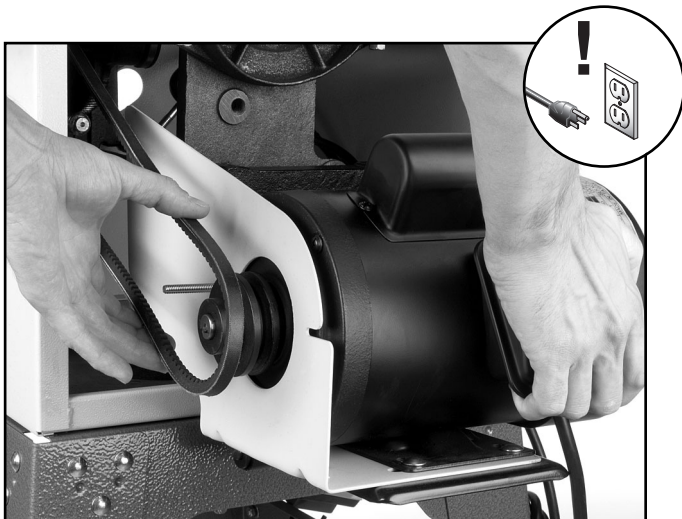

Figure 22. V-belt installation.

10. Place a straightedge across the arbor pulley and the motor pulley. The straightedge should align across the face of both pulleys (**Figure 23**).

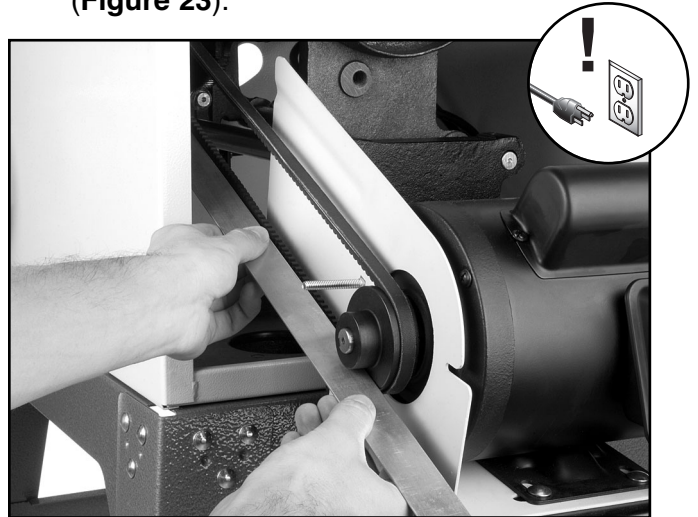

Figure 23. V-belt alignment.

— If the pulleys are not aligned, loosen the bolts tightened in **step 4** and reposition the motor.

11. Secure the V-belt guard to the V-belt plate with the brass wing nut (**Figure 24**).

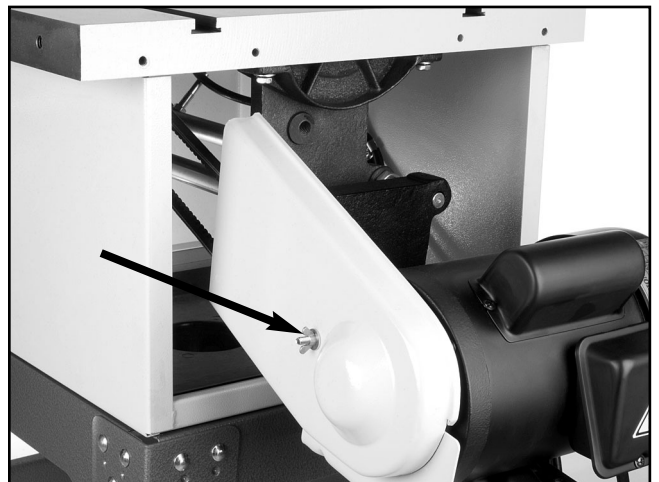

Figure 24. Installed pulley cover.



Extension Wings

Components and Hardware Needed:	Qty
Extension Wings	2
Hex Bolts $\frac{7}{16}$ "-14 x $1\frac{1}{4}$ "	6
Lock Washers $\frac{7}{16}$ "	6
Flat Washers $\frac{7}{16}$ "	6

Tools Needed:

17mm Wrench or Socket.....	1
Straightedge	1

To install the extension wings:

1. Align the extension wing holes with the holes on the cast iron table edges.
2. Using a 17mm wrench, secure the extension wings to the cast iron table with the hex bolts, the lock washers, and the flat washers.
3. Lay a straightedge across the extension wings and cast iron table surface.

— If the straightedge lays flat across all three surfaces, then skip ahead to the next sub-section.

— If either extension wings tilts down, loosen it and place a strip of masking tape along the bottom edge of the table (**Figure 25**).

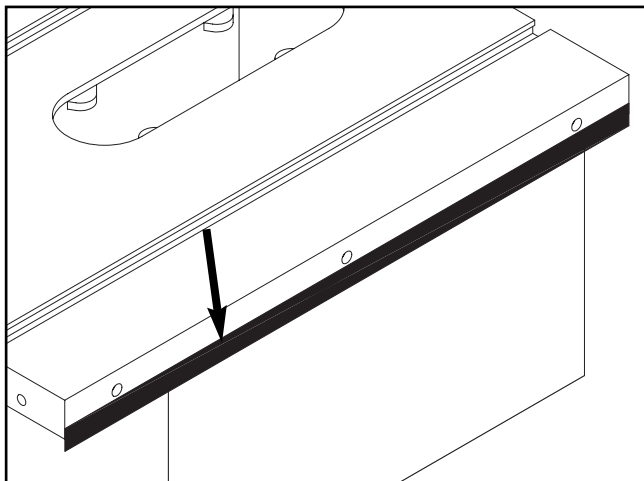

Figure 25. Masking tape location for adjusting extension table up.

— If either extension wing tilts up, loosen it and place a strip of masking tape along the top edge of the table (**Figure 26**).

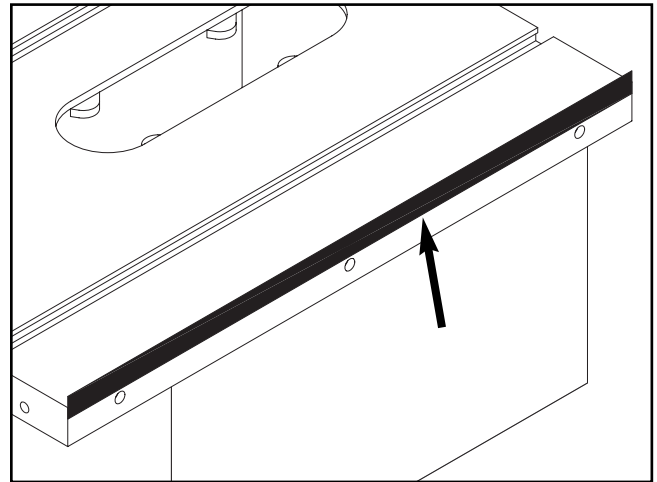

Figure 26. Masking tape location for adjusting the extension wing down.

4. Tighten the extension wing bolts and repeat **step 3**.
5. Once all three table surfaces are level, remove the excess masking tape with a razor blade.



Blade

Components and Hardware Needed:	Qty
Blade (Not Included)	1
Arbor Nut (Left Hand Threads)	1
Arbor Flange	1

Tools Needed:	
23mm Wrench	1

To install the blade guard:

1. Using a 23mm wrench, loosen the arbor nut.
Note—*The arbor nut has left hand threads.*
2. Remove the arbor nut and the arbor flange.
3. Slide the blade over the arbor. Note—*Make sure the teeth are pointing in the correct direction (Figure 27).*

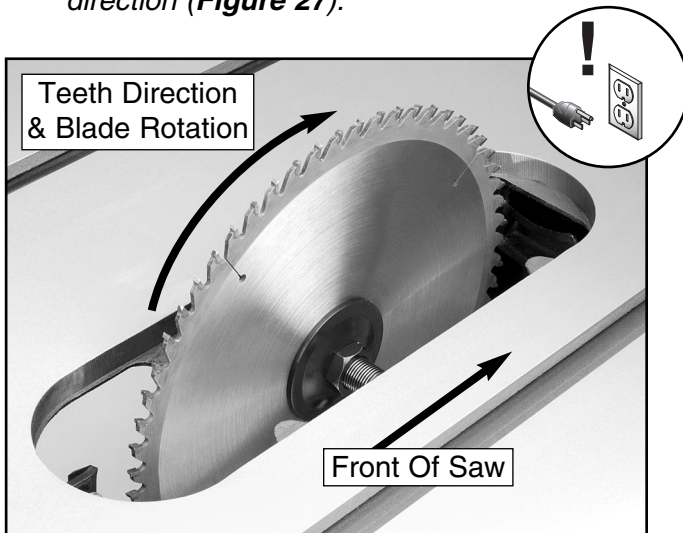

Figure 27. Correct blade direction.

4. Re-install the arbor flange and the arbor nut and tighten them against the blade.



Fence

Install the Shop Fox® fence and rails according to the fence manual.



Switch

Components and Hardware Needed:	Qty
Switch	1

Tools Needed:	
10mm Wrench or Socket.....	1

To install the switch:

1. Remove the far left hex bolt that secure the front fence rail to the fence bracket.
2. Using a 10mm wrench, secure the switch to the fence rail with the hex bolt (Figure 28) removed in step 1.

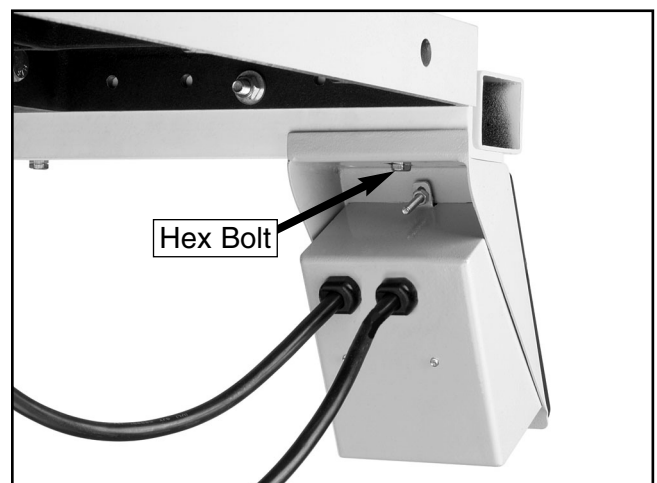

Figure 28. Installed switch.



Miter Gauge

Components and Hardware Needed:	Qty
Miter Gauge Body	1
Miter Bar	1
Threaded Handle $\frac{5}{16}$ "-18 x 1"	1
Flat Washer $\frac{5}{16}$ "	1

To assemble the miter gauge:

1. Insert the peg on the bottom of the miter gauge body into the unthreaded hole in the miter bar.
2. Install the threaded handle and flat washer through the miter gauge body and into the threaded hole in the miter bar (**Figure 29**).



Figure 29. Assembled miter gauge.



Blade Guard

Components and Hardware Needed:	Qty
Blade Guard	1
Blade Guard Mounting Bracket Assembly.....	1
Blade Guard Mounting Shaft.....	1
Hex Nut $\frac{1}{2}$ "-12	1
Flat Washer $\frac{1}{2}$ "	1

Tools Needed:

12mm Wrench or Socket.....	1
----------------------------	---

To install the blade guard:

1. Secure the blade guard mounting shaft into the trunnion with the hex nut and the flat washer.
2. Slide the blade guard mounting bracket onto the end of the shaft (**Figure 30**).

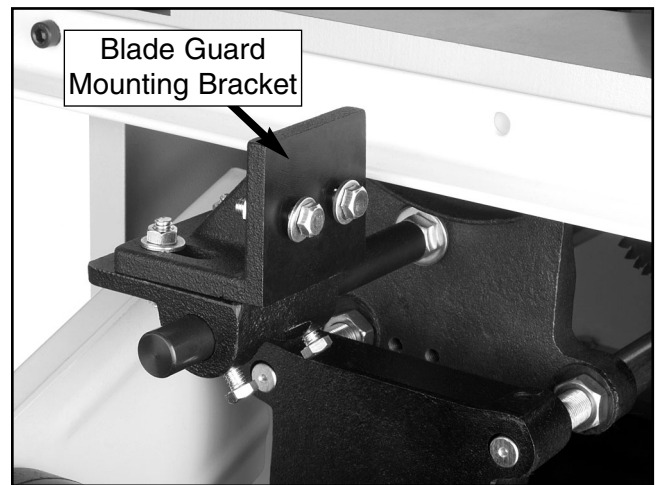

Figure 30. Blade guard mounting assembly.

3. Using a 12mm wrench, secure the blade guard mounting bracket to the blade guard mounting shaft by tightening the hex bolts on the bracket. Note—*Do not worry about precise placement at this time.*
4. Slide the blade guard fingers onto the blade guard mounting bolts (**Figure 31**).

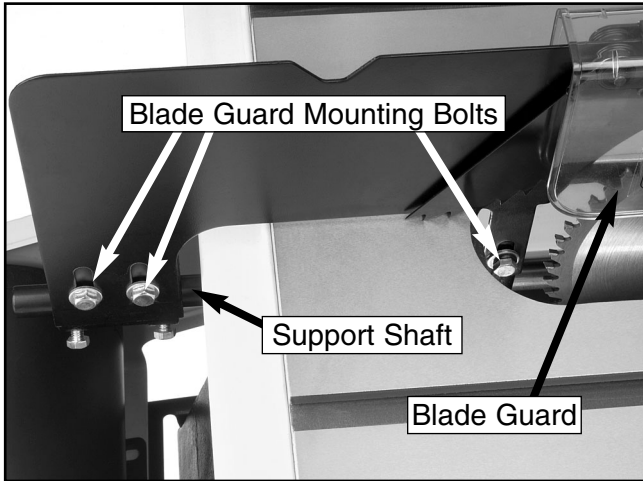

Figure 31. Blade guard components.

5. Tighten the bolts to secure the blade guard.
6. Using a machinist's or a combination square, align the face of the blade guard perpendicular to the table surface (**Figure 32**).

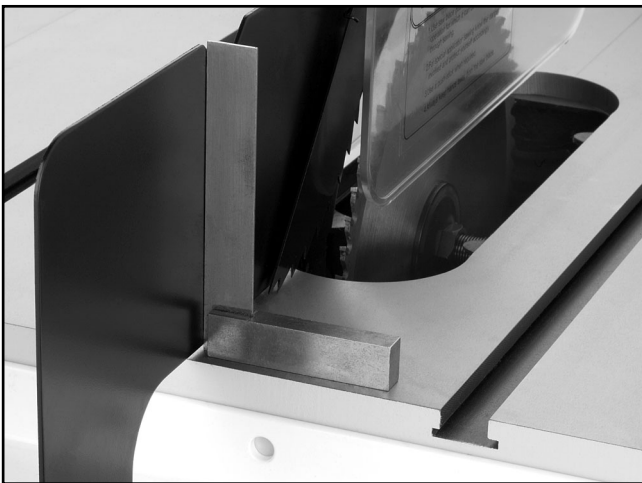

Figure 32. Blade guard perpendicular to the table.

7. Place a straightedge against the face of the saw blade and the blade guard (**Figure 33**).

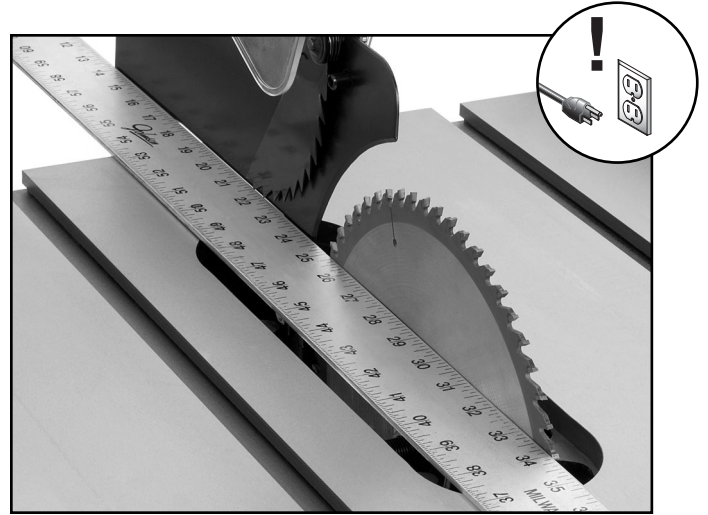

Figure 33. Checking alignment of blade guard.

- If the saw blade and the blade guard are aligned, then skip ahead to the next subsection.
- If the blade guard is not aligned correctly behind the blade (**Figure 34**), then adjust the blade guard mounting bracket and the front blade guard support so they align correctly (**Figure 35**).

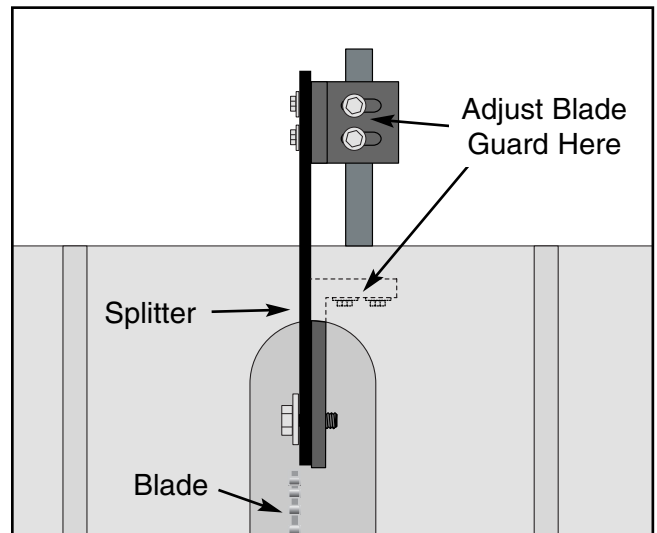

Figure 34. Incorrect blade guard alignment.

Table Insert

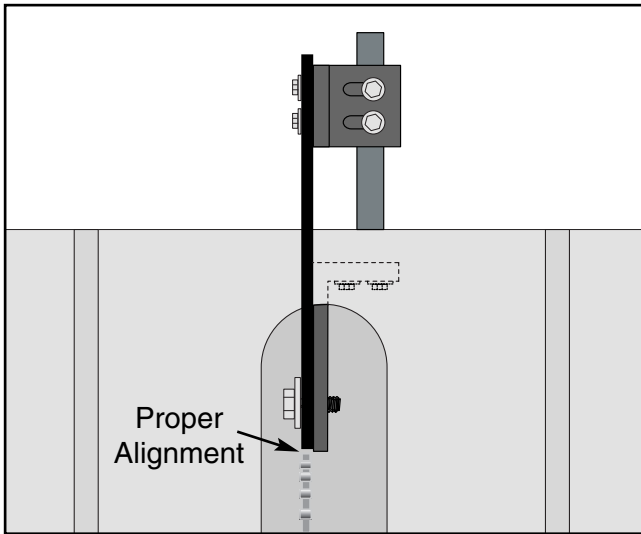

Figure 35. Correct blade guard alignment.

8. Repeat **steps 6-7**.
9. Adjust the saw blade through its complete tilt and height adjustments. The saw blade should not make contact with any part of the blade guard. If it does, re-adjust it as necessary.



Components and Hardware Needed:	Qty
Standard Blade Table Insert	1
Dado Blade Table Insert	1

Tools Needed:	
3mm Allen Wrench	1

To install the table insert:

1. Place the table insert into the table.
2. Place a straightedge across the table and the table insert.
3. Using a 3mm Allen wrench, adjust the table insert flush with the table by rotating the setscrews as shown in **Figure 36**.

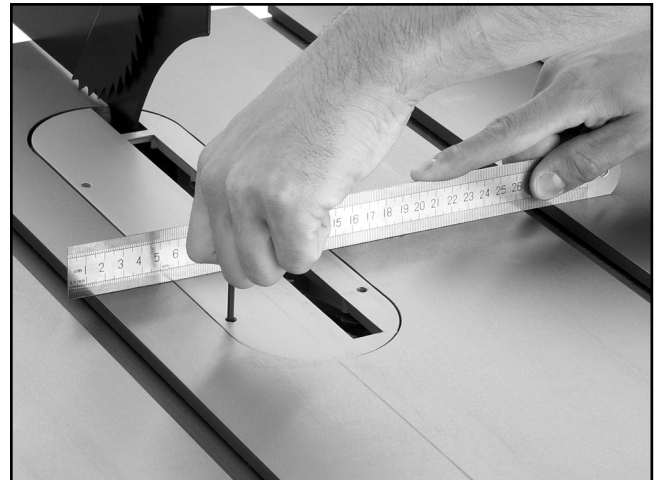
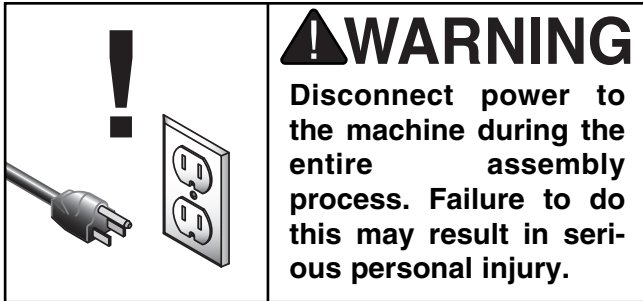

Figure 36. Adjusting the table insert.



Power Cord



G0444

The Model G0444 is prewired to operate on a 110V power source. Connect the power cord to the motor according to **Figure 37**.

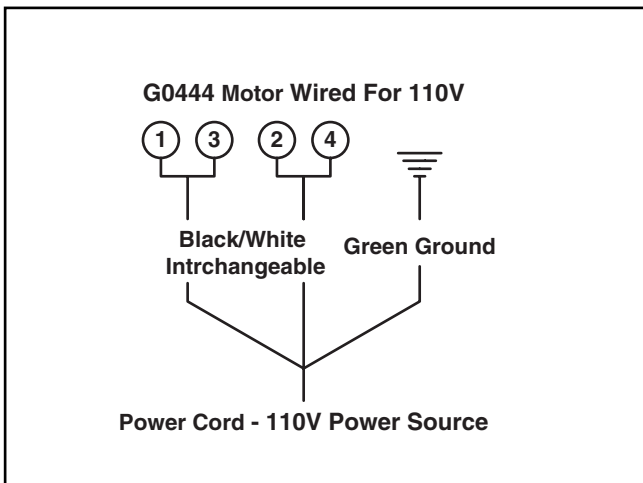

Figure 37. G0444 Wiring.

G0444Z

The Model G0444Z is prewired to operate on a 220V power source. Connect the power cord to the motor according to **Figure 38**.

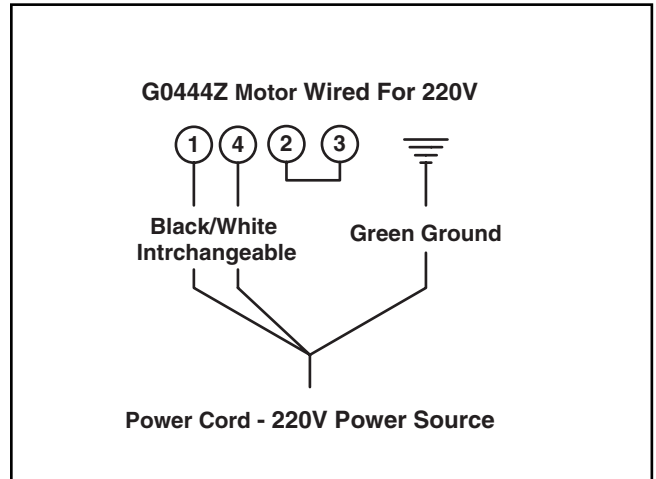
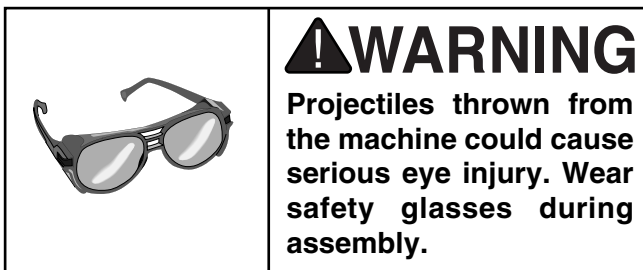
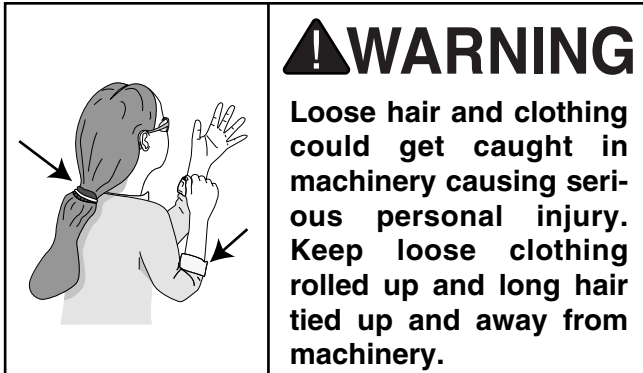

Figure 38. G0444Z Wiring.

Note—Refer to Section 3: Circuit Requirements and the wiring diagram at the back of this manual for information on rewiring the G0444 for 220V and the G0444Z for 110V.



Start Up



Before starting the machine:

1. Read the entire instruction manual.
2. Make sure the blade guard and splitter are installed and correctly adjusted.
3. Make sure all tools and objects have been removed from the machine.
4. Review *Section 3: Circuit Requirements*.
5. Keep a finger on the *STOP* button at all times during the test run.

Starting the machine:

The Model G0444/G0444Z is operated by a push button switch that is clearly labeled *START/STOP*.

This switch can be locked out by sliding a padlock through the *START* button (**Figure 38b**) when the machine is not in use.

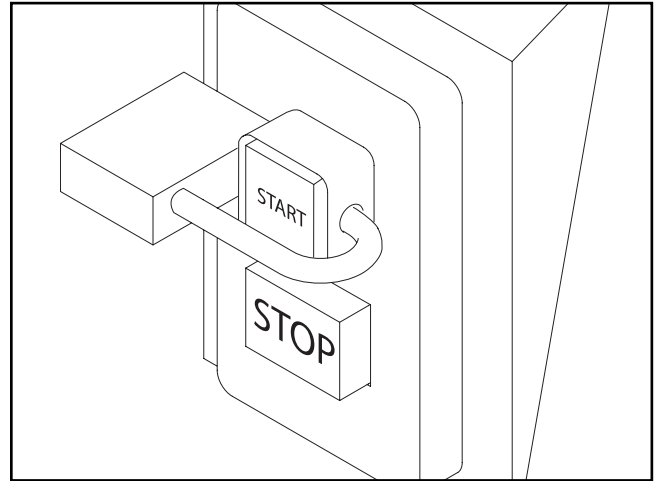

Figure 38b. Locked power switch



Recommended Adjustments

The adjustments listed below have been performed at the factory and no further setup is required to operate the machine.

However, because of the many variables involved with shipping, we recommend at least check the following adjustments to ensure the best possible results from the new machine.

All of these adjustments are covered in step-by-step detail in *Section 8: Service Adjustments*.

Recommended adjustment checklist:

- Blade Parallelism (**page 41**)
- 45° Blade Stop (**page 44**)
- 90° Blade Stop (**page 44**)



SECTION 6: OPERATIONS

General

! WARNING

Damage to your eyes, lungs, and ears could result from failure to wear safety glasses, a respirator, and hearing protection while sanding with this machine.



! WARNING

Loose hair and clothing could get caught in machinery and cause serious personal injury. Keep loose clothing rolled up and long hair tied up and away from machinery.

! WARNING

Keep the blade guard in the down position at all times. Failure to do this could result in serious personal injury or death.

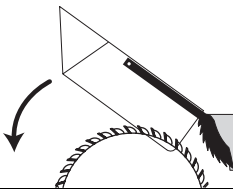

Blade Selection

Rip blade features:

- Best for cutting with the grain of the work-piece.
- 20-40 teeth.
- Flat-top ground tooth profile.
- Large gullets for large chip removal.

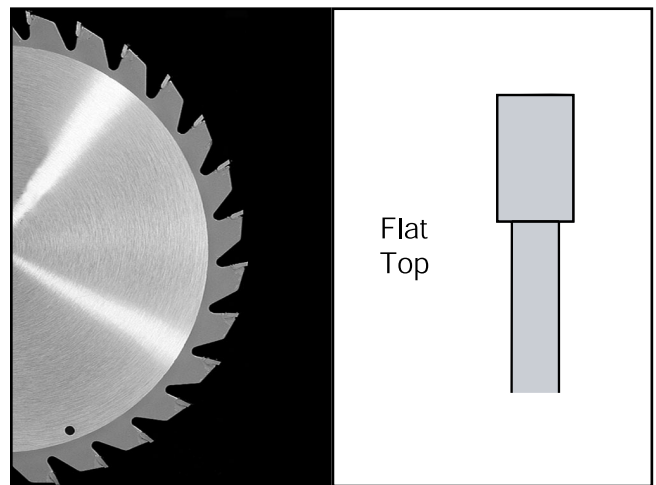

Figure 39. Rip blade.

Crosscut blade features:

- Best for cutting across the grain of the work-piece.
- 60-80 teeth.
- Alternate top bevel tooth profile.
- Small hook angle and a shallow gullet.

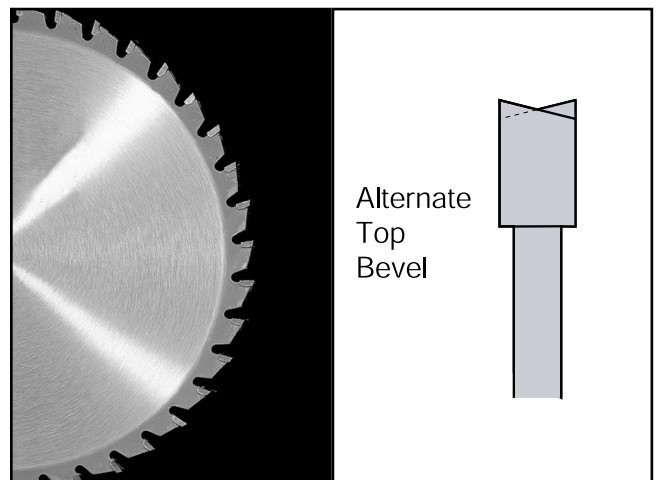

Figure 40. Crosscutting blade.

Combination blade features:

- Adequate for cutting both with and across the grain.
- 40-50 teeth.
- Alternate top bevel and flat, or alternate top bevel and raker tooth profile.
- Teeth are arranged in groups of five.
- Gullets are small and shallow within the groups of five teeth, similar to a cross-cut blade; then large and deep between each group of five, like a ripping blade.

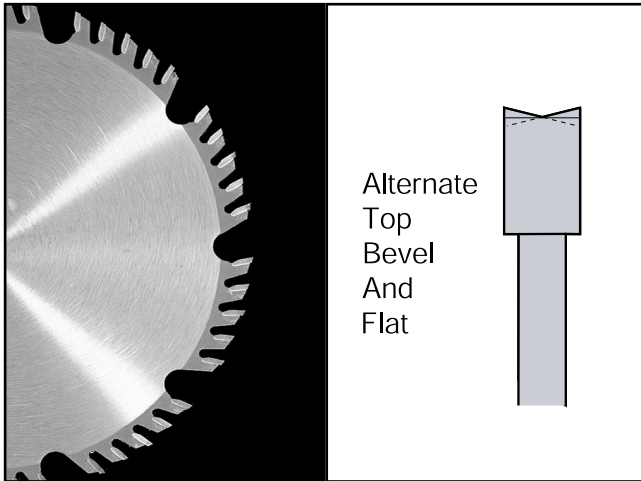

Figure 41. Combination blade.

Laminant blade features:

- Best for cutting plywood or veneer.
- 40-80 teeth.
- Triple chip tooth profile.
- Very shallow gullet.

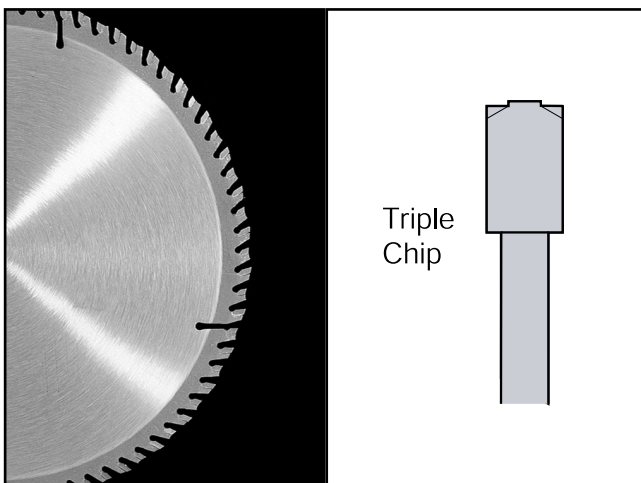

Figure 42. Laminate blade.

Dado Blades:

There are two types of dado blades: stacked and wobble.

- **Stacked Dado Blade**—These dedicated dado cutting blades consist of a set of up to 8 individual blades. Multiple cutters are "stacked" between two outside blades. The width of the dado is determined by the combination of cutters that are "stacked" together. The dado is cut in a single pass leaving a smooth and square channel in the face of the workpiece. Stacked dado blades are the most expensive option but are worth considering if your projects require a lot of visible dado cuts. A typical stacked dado blade is shown in **Figure 43**.
- **Wobble Dado Blade**—Also a dedicated dado blade, a wobble blade usually consists of a single blade that is tilted on the arbor shaft while it is spinning. The channel is cut in the face of the workpiece as the blade passes through its pre-adjusted width of travel. Wobble blades are an inexpensive option when visibly pleasing channels are not a concern.

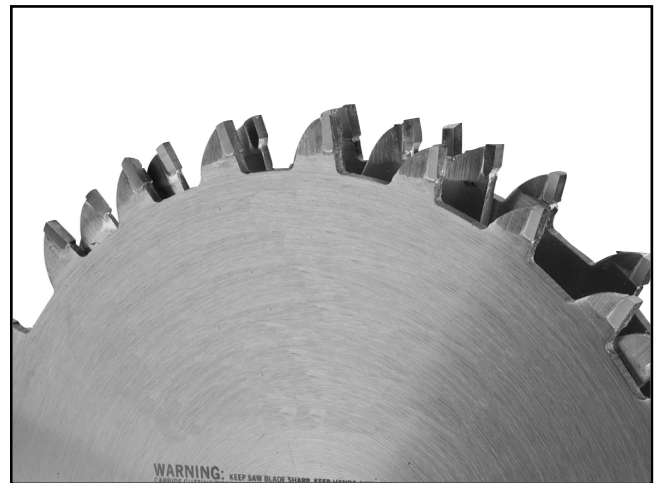

Figure 43. Stacked dado blade.

Note—This section on blade selection is by no means comprehensive. Always follow the saw blade manufacturer's recommendations to ensure safe and efficient operation of your table saw.



Crosscutting

Crosscutting means cutting across the grain of the workpiece. In workpieces without grain (i.e. MDF, particleboard) crosscutting simply means cutting across the width of the workpiece.

Crosscuts are made with the miter gauge. There are two miter gauge slots in the table top. Use the one that works best for the piece being crosscut.

To make a 90° crosscut using the miter gauge:

1. Adjust the miter gauge to the 90° position.
2. Move the fence completely away from the cutting operation.
3. Position the miter gauge in one of the two miter slots.
4. Adjust the blade height so the highest saw tooth protrudes approximately ¼" above the workpiece.
5. Hold the workpiece against the miter gauge and line up the cut with the blade.
6. Turn on the saw and allow it to reach full speed.
7. Hold the workpiece firmly against the face of the miter gauge and ease it into the blade as shown in **Figure 44**.



Figure 44. Crosscutting operation.

WARNING

Turn off the saw and allow the blade to come to a complete stop before removing the cut-off piece. Failure to follow this warning could result in serious personal injury



Ripping

Ripping means cutting with the grain of the workpiece. In other materials such as MDF or plywood, ripping simply means cutting lengthwise.

To make a rip cut:

1. Set the fence to the desired width of cut on the scale.
2. Adjust the blade height so the highest saw tooth protrudes approximately $\frac{1}{4}$ " above the workpiece.
3. Joint one long edge of the workpiece on a jointer.

!WARNING

Never attempt to rip a board that does not have one perfectly straight edge. Always guide the straight edge of the board against the rip fence. Failure to do this could result in kickback and serious personal injury.

4. Set up safety devices such as featherboards or other anti-kickback devices.
5. **With the saw unplugged from the power source**, rotate the blade to make sure it does not come into contact with any of the safety devices.
6. Plug the saw into the power source, turn it *ON*, and allow it to reach full speed.
7. The jointed edge of the workpiece must slide against the fence during the cutting operation.

8. Using a push stick, feed the workpiece through the saw blade as shown in **Figure 45**, until the workpiece is completely past the saw blade.



Figure 45. Ripping operation.

!WARNING

Turn off the saw and allow the blade to come to a complete stop before removing the cut-off piece. Failure to follow this warning could result in serious personal injury.



Dado Cutting

Commonly used in furniture joinery, a dado is a straight channel cut in the face of the workpiece. Dadoes can be cut using either a dedicated dado blade or a standard saw blade.

⚠️ WARNING

Dado operations present very real hazards requiring proper procedures to avoid serious injury. The chance of kickback is always greater when dado blades are used so extra care must be taken. Any movement of the workpiece away from the fence will cause kickback. Be certain that stock is flat and straight. Failure to follow these warnings could result in serious personal injury.

⚠️ WARNING

Never perform a through cut operation with a dado blade. A dado blade was designed to make non-through cuts only. Failure to follow this warning could result in serious personal injury.

To use a stacked or wobble dado blade:

1. **Disconnect the machine from the power source!**
2. Remove the table insert, the blade guard, and the saw blade.
3. Attach and adjust the dado blade system as recommended in the dado blade manufacturer's instructions.
4. Install the dado table insert.
5. Raise the dado blade up to the desired depth of cut (depth of dado channel desired).
6. If dadoing along the long length of the workpiece, adjust the distance between the fence and the inside edge of the blade as shown in **Figure 46**.

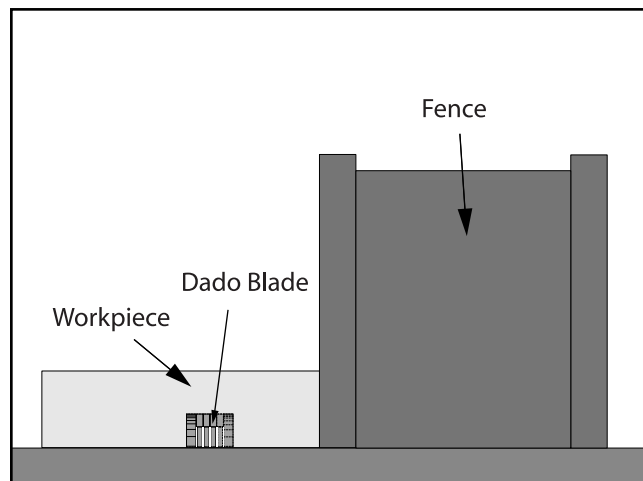

Figure 46. Single-blade dado cut.

7. Reconnect the saw to the power source.
8. With one finger ready to push the *STOP* button, turn the saw *ON*. The blade should run smooth with no vibrations or wobbling.
9. When the blade has reached full speed, perform a test cut with a scrap piece of wood.
10. If the cut is satisfactory, repeat the cut with the actual workpiece.

Using a standard saw blade:

1. Mark the width of the dado cut on the workpiece. *Note—Include marks on the edge of the workpiece so the cut path can be aligned when the workpiece is lying on the table.*
2. Raise the blade to the desired depth of cut (depth of dado channel desired).
3. Align the blade to cut one of the dado sides as shown in **Figure 47**.

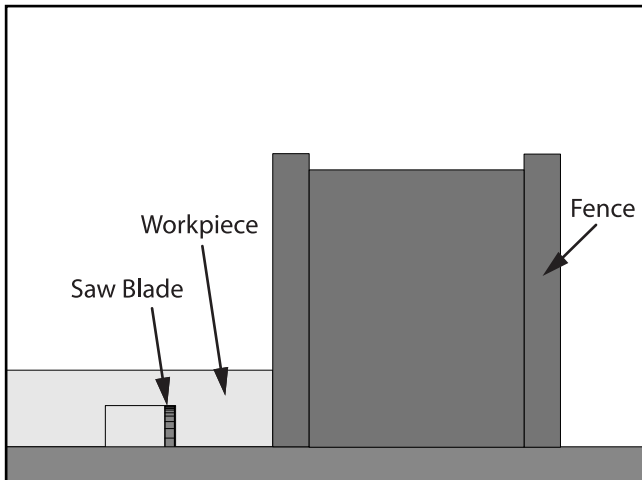

Figure 47. Single-blade dado cut.

4. Turn on the saw and allow the blade to reach full speed.
5. Perform the cutting operation.

6. Re-adjust the fence so the blade is aligned with the other edge of the intended dado channel (**Figure 48**). *Note—Be sure to keep the cuts within your marks; otherwise, the dado will be too big.*

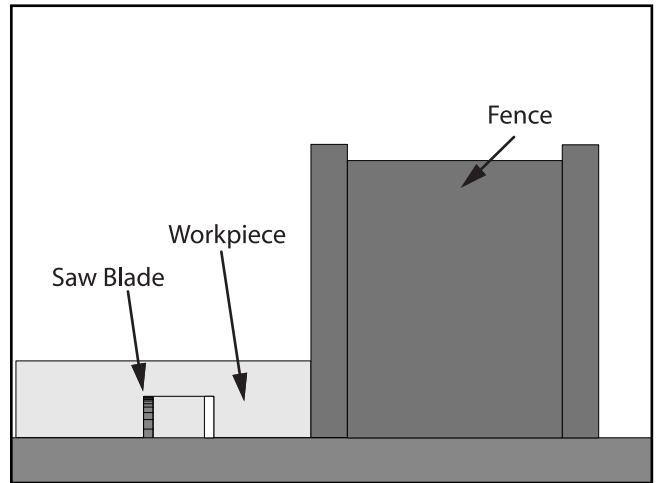

Figure 48. Single-blade dado cut.

7. Continue making cuts toward the center of the dado with your subsequent cuts until the dado is complete.

! WARNING

Always replace the blade guard after dadoing is complete. Failure to follow this warning could result in serious personal injury.



Rabbet Cutting

Commonly used in furniture joinery, a rabbet is a L-shaped groove cut in the edge of the workpiece. Rabbets can be cut with either a dado blade or a standard saw blade.

To attach a sacrificial fence:

Rabbet cutting on the edge of the workpiece requires the use of a sacrificial fence attachment. See **Figure 49**. The sacrificial fence can be made from a piece of wood that is as long as the metal fence and $\frac{3}{4}$ " thick. Once the sacrificial fence has been cut, attach it to the metal fence with screws or clamps, making sure they are all secure and tight.

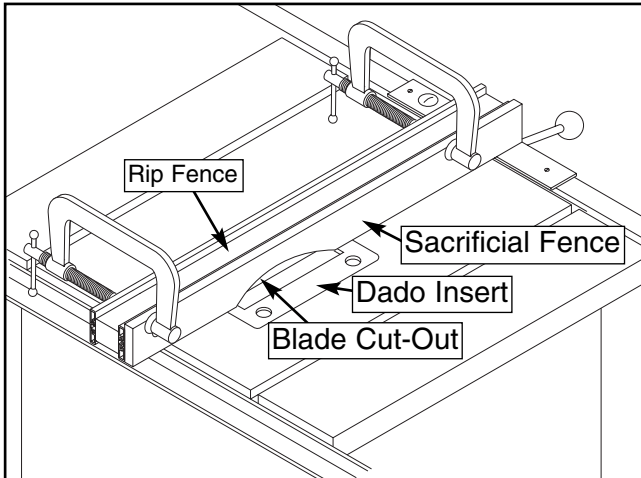

Figure 49. Sacrificial fence.

⚠ CAUTION

Always use push sticks, featherboards, push paddles and other safety accessories whenever possible to increase safety and control during operations which require that the blade guard and splitter must be removed from the saw. ALWAYS replace the blade guard after dadoing is complete.

Cutting rabbets with the dado blade:

1. Adjust the saw blade to the maximum height needed for the rabbeting operation.
2. Adjust the fence and align the workpiece to perform the cutting operation as shown in **Figure 50**.

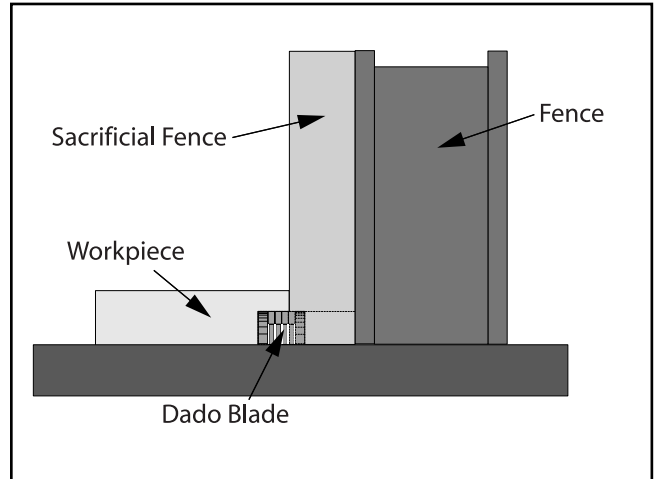

Figure 50. Rabbet cutting.

3. Reconnect the saw to the power source and turn the saw *ON*.
4. When the blade has reached full speed, perform a test cut with a scrap piece of wood.
5. If the cut is satisfactory, repeat the cut with the final workpiece.

Cutting rabbets with the standard blade:

Note—Cutting rabbets with a standard saw blade **DOES NOT** require the use of a sacrificial fence.

1. Clearly mark the width of the rabbet cut on the workpiece. Note—*Include marks on the edge of the workpiece to clearly identify the intended cut while it is laying flat on the saw table.*
2. Raise the blade up to the desired depth of cut (depth of rabbet channel desired).
3. Adjust the fence so the blade is aligned with the inside of your rabbet channel as shown in **Figure 51**.

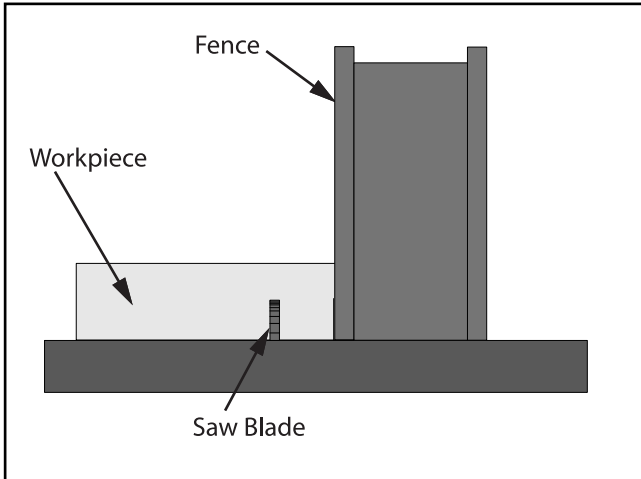

Figure 51. Rabbet cutting.

4. Turn the saw *ON*.
5. When the blade has reached full speed, perform a test cut with a scrap piece of wood.
6. If the cut is satisfactory, repeat the cut with the final workpiece.
7. Rotate the workpiece as shown in **Figure 52**.

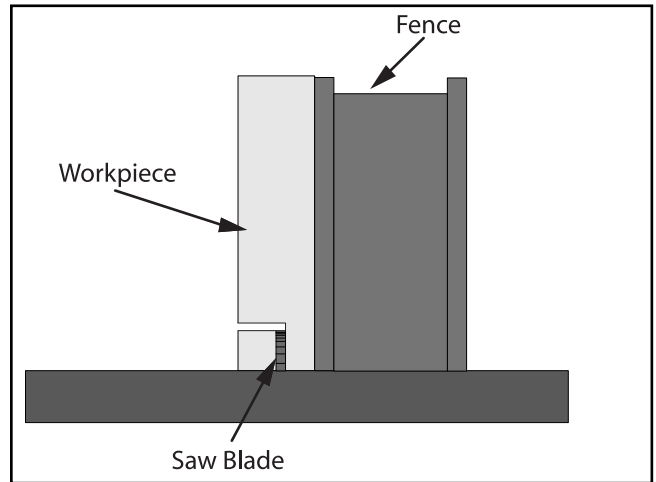
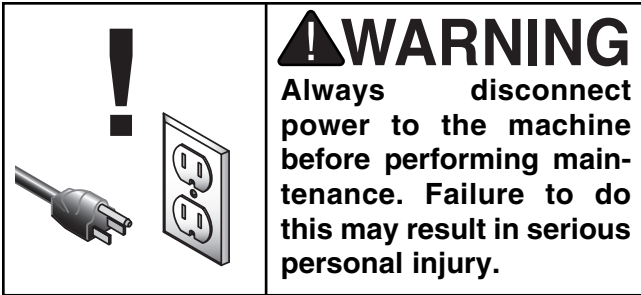

Figure 52. Rabbet cutting.

8. Perform the second cut to complete the rabbet.



SECTION 7: MAINTENANCE



Cleaning

Clean the Model G0444/G0444Z according to the schedule below to ensure maximum performance. Note—*The following maintenance schedule assumes the saw is being used every day.*

Daily:

- Wipe down the table surface and grooves with a rust preventive such as SLIPIT® (Grizzly items G5562 & G5563).
- Clean the pitch and resin from the saw blade with OxiSolv® Blade & Bit Cleaner (Grizzly item G1955).

Weekly:

- Clean the motor housing with compressed air.
- Wipe down the fence rails with a dry silicon lubricant such as Spraway® Silicon Lubricant (Grizzly item G2545).



Lubrication

Lubricate the areas indicated below every 12 months.

1. **Blade angling trunnions.** These should be lubricated with 6 or 7 drops of light machine oil.
2. **Blade height trunnion.** This should also be lubricated with 6 or 7 drops of light machine oil.
3. **The 2 worm gears** should be lubricated with an automotive wheel bearing grease.

These points can be reached from the back of the machine. Check all adjustments after lubricating.



Miscellaneous

Always be aware of the condition of your machine. Routinely check the condition of the following items and repair or replace as necessary:

- Mounting bolts
- Power switch
- Saw blade
- Blade guard



V-Belts

To ensure optimum power transmission from the motor to the blade, the V-belt must be in good condition (free from cracks, fraying and wear). Check the V-belt at least every 3 months; more often if the saw is used daily.



Bearings

The bearings are sealed and pre-lubricated and require no lubrication during their usable life. However, your saw components will operate at their best if the bearing surfaces are kept clean.



SECTION 8: SERVICE ADJUSTMENTS

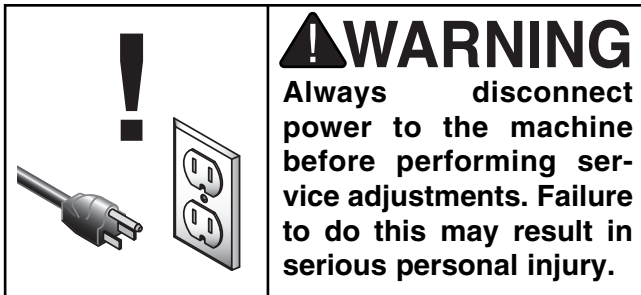

About Service

This section is designed to help the operator with adjustments that were made at the factory and that might also need to be made during the life of the machine.

This section is provided for your convenience—it is not a substitute for the Grizzly Service Department. If any adjustments arise that are not described in this manual, then feel free to call the Grizzly Service Department at (570) 546-9663.

Similarly, if you are unsure of how to perform any procedure in this section, the Grizzly Service Department will be happy to guide you through the procedures or help in any other way.



Blade Parallelism

To check and adjust blade parallelism:

1. **Disconnect the machine from the power source!!**
2. Raise the blade to its highest position.
3. Tilt the blade to 90°. Using an adjustable square, measure the distance (A) between the miter slot and the front of the blade as shown in **Figure 53**.

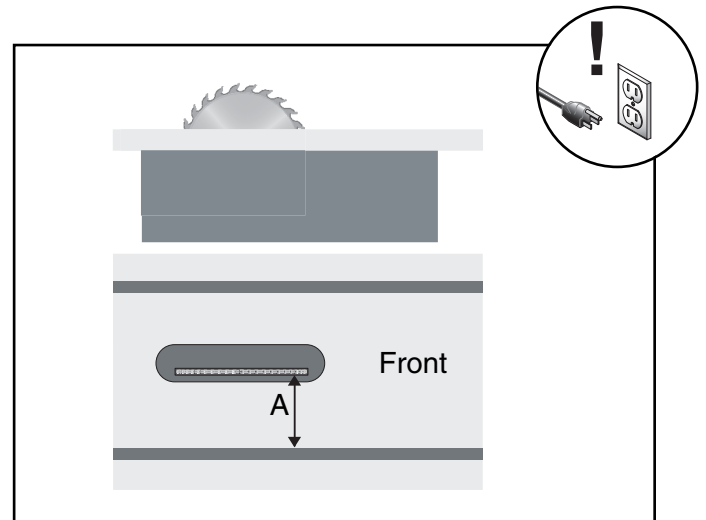

Figure 53. 90° blade parallelism measurement.

4. **Rotate the blade 180°** and measure the distance (B) between the miter slot and the back of the blade as shown in **Figure 54**.

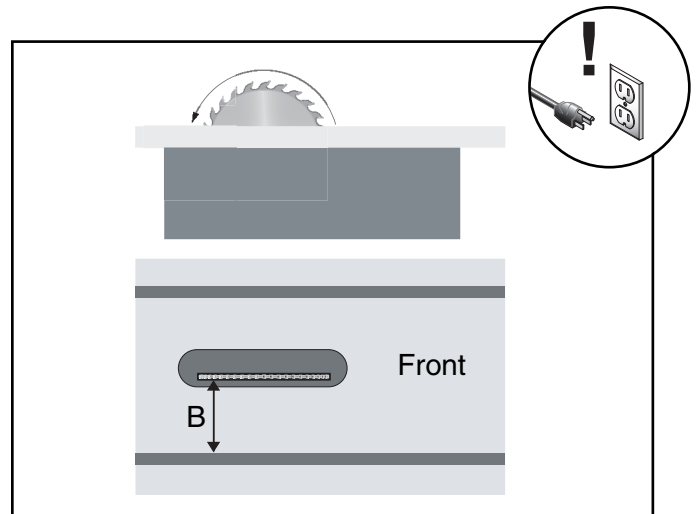

Figure 54. 90° blade parallelism measurement.

5. Make note of the difference between the two measurements on a piece of paper.

6. Tilt the blade to 45° and repeat **Steps 3-5**.

— If the difference was less than 0.004" when the blade was positioned at 90° and 45°, then the blade parallelism is set correctly. Skip to the next sub-section.

— If the difference was greater than 0.004" when the blade was positioned at 90° or 45°, then the trunnion assembly below the table needs to be adjusted. Continue with the next step.

7. Remove the fence and the blade guard.

8. Lower the saw blade completely below the table surface.

9. Flip the saw upside down on the floor. Note—*Lay clean and staple-free cardboard or a blanket on the floor to prevent damage to the cast iron table.*

10. To maintain the trunnion assembly as one unit, place a bar clamp across the entire trunnion assembly as shown in **Figure 55**.

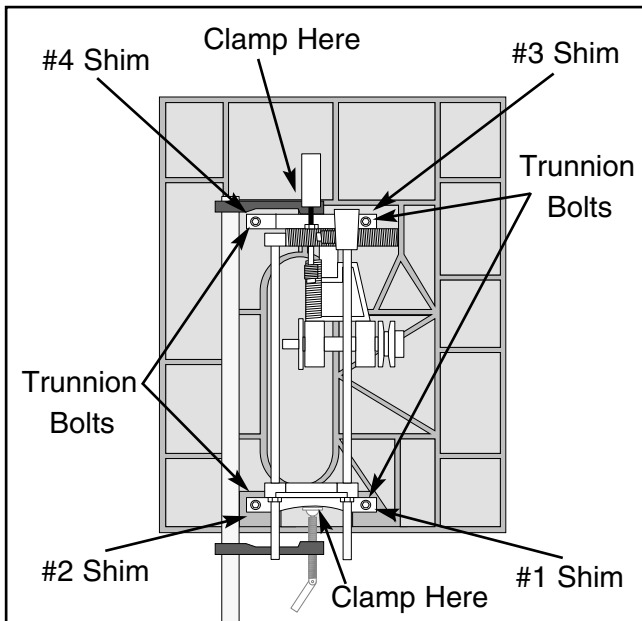

Figure 55. Underside view of table/trunnion assembly.

11. Refer back to the measurements taken in **steps 3-6**.

— If the blade was not parallel in the 90° position, then proceed to the set of instructions titled "To Shift The Trunnion."

— If the blade was not parallel in the 45° position, then proceed to the set of instructions titled "To Shim The Trunnion."

To Shift The Trunnion:

1. Loosen the trunnion bolts (**Figure 55**).

2. Move the trunnion assembly according to the difference measured when the blade was in the 90° position.

3. Tighten the trunnion bolts.

4. Flip the saw rightside up and repeat **steps 2-6** on **page 41**.

5. Once the miter slot is adjusted parallel to the blade, recheck all measurements and be sure the table mounting bolts are secure.

6. Re-attach the blade guard and fence.

7. Verify that the blade guard is correctly aligned with the blade.

To Shim The Trunnion:

1. Loosen the trunnion bolts (**Figure 55**).

2. Using **Figures 56 & 57**, shim the trunnion assembly according to the difference measured when the blade was in the 45° position.

— If the distance of A is shorter than B, shim(s) will need to be placed under corners #1 and #2.

— If the distance of B is shorter than A, shim(s) will need to be placed under corners #3 and #4.

Note—*Very thin shim stock works well, just make sure they are all the same thickness and you put an equal number under each of the two corners.*

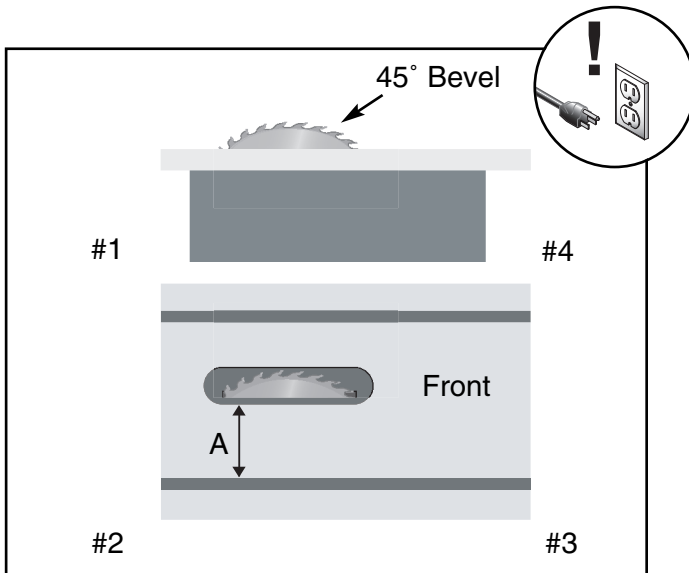

Figure 56. 45° blade parallelism measurement.

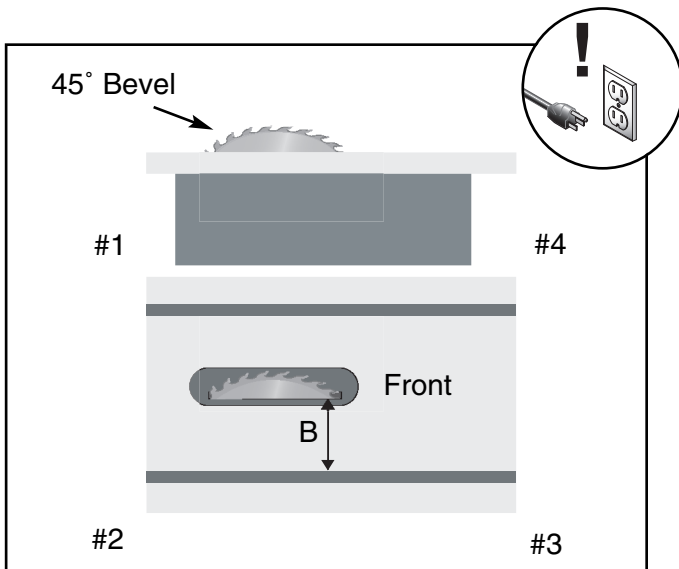

Figure 57. 45° blade parallelism measurement.

3. Tighten down one trunnion bolt a small amount and then move on to each of the others, tightening each down the same amount.
4. Continue to rotate through the bolts, tightening them a little each time until they are all secure.
5. Flip the saw rightside up and repeat **steps 2-6** on **page 41**.
6. Once the miter slot is adjusted parallel to the blade, recheck all measurements and be sure the table mounting bolts are secure.
7. Re-attach the blade guard and the fence.
8. Verify that the blade guard is correctly aligned with the blade.

NOTICE

If the trunnion assembly is loosened in the future, make note of the shim locations and re-assemble accordingly.



45° & 90° Stops

The Model G0444/G0444Z Table Saw is equipped with positive stops at 45° and 90°. When properly adjusted, they provide quick and precise guides for blade bevel adjustment.

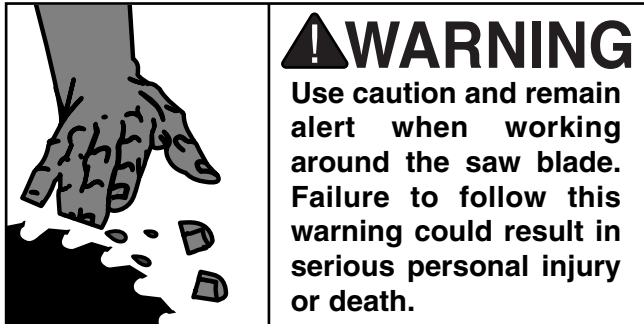

To set the 45° & 90° stops:

1. Disconnect the machine from the power source!!
2. Raise the saw blade to its maximum height by turning the front handwheel clockwise.
3. Adjust the blade to the 90° position.
4. Place a machinist's square against the blade and table surface, as shown in **Figure 58**.

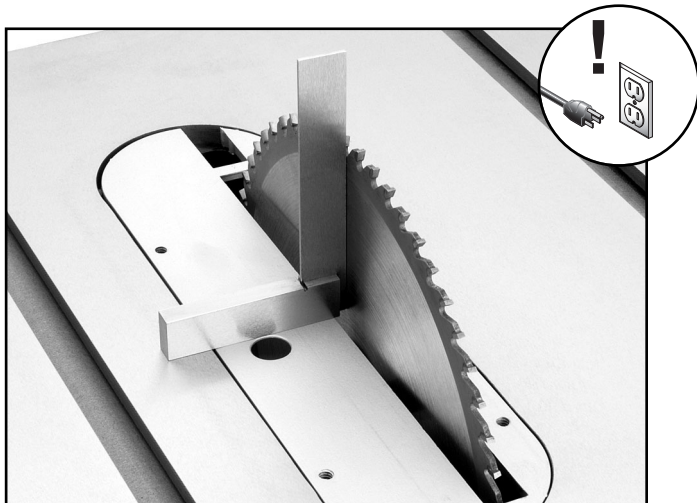

Figure 58. Checking blade angle to table.

5. With the square in place, inspect for gaps along the blade and square.

6. If a gap exists at either the top or bottom of the square, loosen the lock nut (A) and adjustment bolt (B) shown in **Figure 59**.

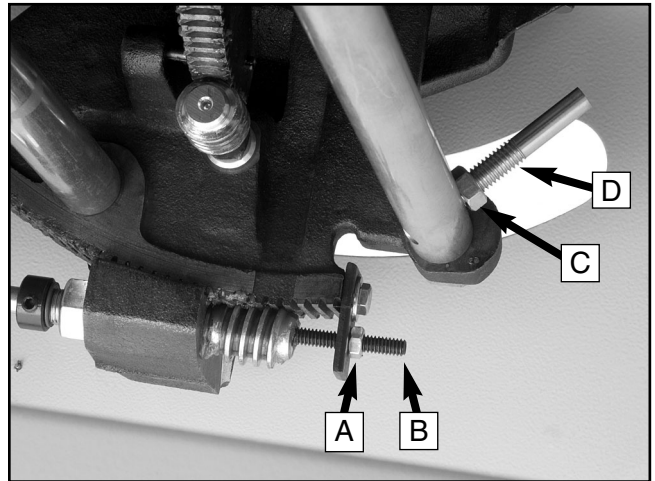

Figure 59. 90° and 45° stop bolt adjustments.

7. Turn the handwheel until the blade and square are flush from top to bottom.
8. Snug the adjustment screw and tighten the lock nut.
9. Recheck the blade with the square to ensure the screw has not been over-tightened.
10. Using the side handwheel, adjust the blade bevel until you hit the 45° positive stop. Check the bevel with an adjustable square set to 45°.
11. If variations exist, loosen the lock nut (C) and adjust the stop bolt (D) (**Figure 59**) until the blade and square match.
12. Tighten the lock nut and recheck the bevel by adjusting the blade back to 90°, then back to 45°.



Worm Gears

The worm gears on the blade tilt and height hand-wheel shafts can be adjusted to reduce “play” between the worm gear and the trunnion teeth.

To adjust the blade tilt worm gear:

1. **Disconnect the machine from the power source!**
2. Remove the dust port from the bottom of the saw.
3. Loosen the collar setscrew and slide the collar away from the check nut (**Figure 60**).

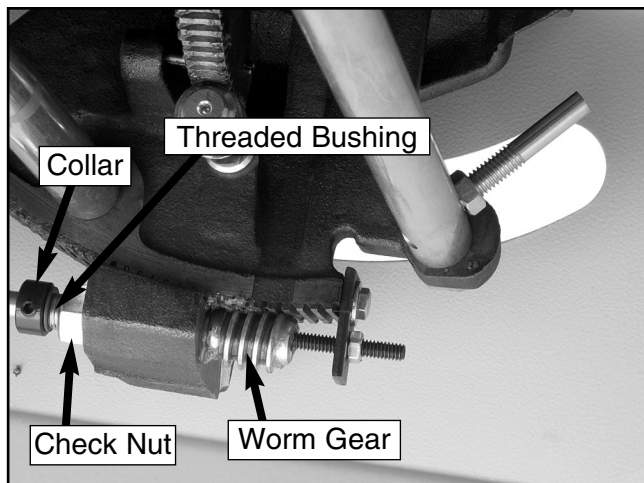

Figure 60. Blade tilt worm gear assembly.

4. Loosen the check nut and thread it completely off of the threaded bushing (**Figure 60**).
5. Place a wrench on the “flats” of the threaded bushing and adjust the worm gear up or down by turning the wrench. Note—*The worm gear and trunnion teeth should mesh with almost no “play.”*
6. Carefully thread the check nut back onto the bushing, being careful not to move the bushing.
7. Tighten the check nut against the casting while using a wrench to hold the threaded bushing stationary.

To adjust the blade height worm gear:

1. **Disconnect the machine from the power source!**
2. Remove the blade height handwheel.
3. Remove the roll pin that is inserted in the handwheel shaft.
4. Slide the various washers and accessories off the shaft to reveal the “flats” of the threaded bushing.
5. Loosen the check nut and thread it back from the trunnion casting.
6. Place a wrench on the “flats” of the threaded bushing and adjust the worm gear up or down by turning the wrench. Note—*The worm gear and trunnion teeth should mesh with almost no “play.”*
7. Carefully thread the check nut back onto the bushing, being careful not to move the bushing.
8. Tighten the check nut against the casting while using a wrench to hold the threaded bushing stationary.



SECTION 9: REFERENCE INFO

General

This section contains the following subsections for the Model G0444/G0444Z: aftermarket accessories, data sheets, wiring diagrams, parts diagrams and list, troubleshooting, and warranty/return information.

If you need parts or help in assembling your machine, or if you need operational information, call the service department at (570) 546-9663. Trained service technicians will be glad to help you.

If you have any comments regarding this manual, please write to Grizzly at the address below:

Grizzly Industrial, Inc.
c/o Technical Documentation
P.O. Box 2069
Bellingham, WA 98227-2069

We recommend you keep a copy of our current catalog for complete information regarding Grizzly's warranty and return policy. If you need additional technical information relating to this machine, or if you need general assistance or replacement parts, please contact the Service Department at the location listed below.

Grizzly Industrial, Inc.
1203 Lycoming Mall Circle
Muncy, PA 17756
Phone: (570) 546-9663
Fax: (800) 438-5901
E-Mail: techsupport@grizzly.com
Web Site: <http://www.grizzly.com>



Aftermarket Accessories

Heavy-Duty SHOP FOX® Mobile Base - G7314
Make your machine mobile with this popular patented mobile base.

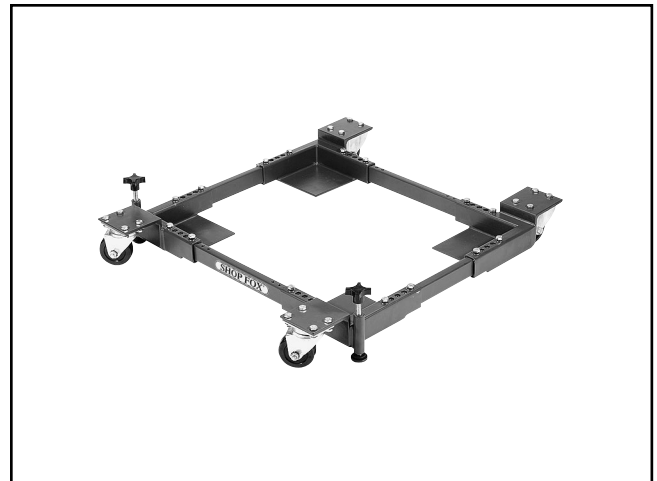

Figure 60. G7314 SHOP FOX® Mobile Base.

Zero-Clearance Table Insert - H0627
Made from special phenolic material, these inserts reduce the risk of kickback and increase the efficiency of the dust collection hook-up.

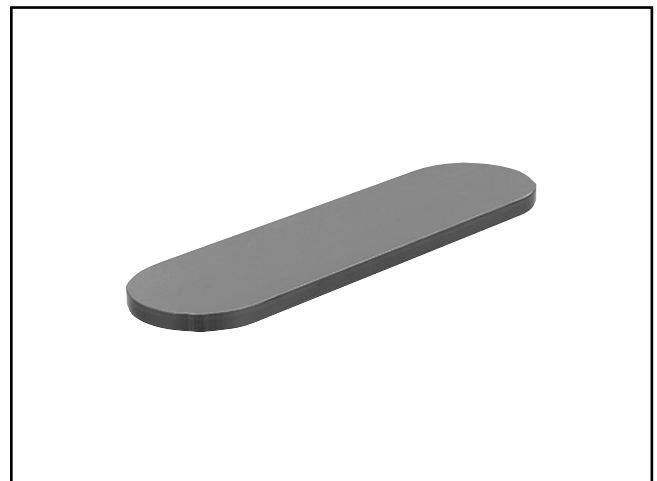

Figure 61. H0627 Zero-Clearance Table Insert.

SHOP FOX® Push Stick - H3308

Measuring 13½" overall, this push stick allows the operator to keep their hands at a safe distance away from the blade or cutter.



Figure 62. H3308 SHOP FOX® Push Stick.

SHOP FOX® Featherboard - H3309

Designed to lock into a standard ¾" x ¾" miter slot, this featherboard is fully adjustable to accommodate a wide range of workpieces. Reduce the likelihood of kickback with this convenient accessory.



Figure 63. H3309 SHOP FOX® Featherboard.

OxiSolv® Blade & Bit Cleaner - G1955

Used to clean the gummy pitch and residue from saw blades and router bits, this high quality cleaner will make blades and bits last longer while improving cutting action.



Figure 64. G1955 OxiSolv®.

SLIPIT® Lubricant - G5562 & G5563

Used on cast iron table surfaces and other unpainted metal surfaces to reduce rust and corrosion. This product is perfect for keeping tools clean, especially during long-term storage.



Figure 65. G5562 & G5563 SLIPIT.





MACHINE DATA SHEET

Customer Service #: (570) 546-9663 • To Order Call: (800) 523-4777 • Fax #: (800) 438-5901

MODEL G0444 CONTRACTOR STYLE SAW

Design Type..... Floor Model

Overall Dimensions:

Table Height35"
 Table Size27"D x 20¹/₈"W
 Table Size W/Extension Wings27"D x 39⁵/₈"W
 Overall Size (W/Extension Wings & Fence Rails).....48¹/₂"D x 57"W
 Miter Gauge T-Slot.....³/₄"W x ³/₈"D
 Blade Tilt.....Right 0-45°
 Shipping Weight (2 Boxes)276 lbs.
 Shipping Weight (Box 1 Of 2)56 lbs.
 Shipping Weight (Box 2 Of 2)220 lbs.
 Net Machine Weight.....257 lbs.
 Box 1 Size37" W x 23" D x 18¹/₂" H
 Box 2 Size66¹/₃" W x 17" D x 6¹/₂" H
 Footprint21" W x 25¹/₂" D

Construction:

Main TablePrecision-Ground Cast Iron
 StandPre-Formed Steel
 Miter GaugeCast Iron/Steel Miter Bar
 TrunnionsCast Iron
 BearingsSealed & Permanently Lubricated
 Guard.....Steel & Clear Plastic
 Extension WingsSheet Metal

Cutting Capacities:

Blade Size10"
 Maximum Depth Of Cut @ 90°3¹/₈"
 Maximum Depth Of Cut @ 45°2¹/₈"
 Maximum Rip Capacity To Right Of Blade.....28¹/₂"
 Maximum Rip Capacity To Left Of Blade10¹/₂"
 Distance From Front Of Table To Center Of Blade16"
 Distance From Front Of Table To Front Of Blade.....11"
 Maximum Width Of Dado Cut¹³/₁₆"

Motor:

TypeTEFC Capacitor Start Induction
 Horsepower1¹/₂ HP
 Phase/CycleSingle-Phase/60 Hz
 Voltage110/220V
 Prewired Voltage110V
 Amps18/9A
 RPM.....3450 RPM
 Power TransferBelt Drive
 Power Switch.....On/Off Push Button

Arbor Shaft:

Dimensions⁵/₈" Diameter x 1¹/₄" Long
 Speed4250 RPM

Features:

.....Table Inserts For Standard & Dado Cutting
4" Dust Hood

Specifications, while deemed accurate, are not guaranteed.

7/2003



MACHINE DATA SHEET

Customer Service #: (570) 546-9663 • To Order Call: (800) 523-4777 • Fax #: (800) 438-5901

MODEL G0444Z CONTRACTOR STYLE SAW

Design Type..... Floor Model

Overall Dimensions:

Table Height35"
 Table Size27"D x 20¹/₈"W
 Table Size W/Extension Wings27"D x 39⁵/₈"W
 Overall Size (W/Extension Wings & Fence Rails).....48¹/₂"D x 57"W
 Miter Gauge T-Slot.....³/₄"W x ³/₈"D
 Blade TiltRight 0-45°
 Shipping Weight (2 Boxes)298 lbs.
 Shipping Weight (Box 1 Of 2)56 lbs.
 Shipping Weight (Box 2 Of 2)242 lbs.
 Net Machine Weight.....283 lbs.
 Box 1 Size37" W x 23" D x 18¹/₂" H
 Box 2 Size66¹/₃" W x 17" D x 6¹/₂" H
 Footprint21" W x 25¹/₂" D

Construction:

Main TablePrecision-Ground Cast Iron
 StandPre-Formed Steel
 Miter GaugeCast Iron/Steel Miter Bar
 TrunnionsCast Iron
 BearingsSealed & Permanently Lubricated
 GuardSteel & Clear Plastic
 Extension WingsPrecision-Ground Cast Iron

Cutting Capacities:

Blade Size10"
 Maximum Depth Of Cut @ 90°3¹/₈"
 Maximum Depth Of Cut @ 45°2¹/₈"
 Maximum Rip Capacity To Right Of Blade.....28¹/₂"
 Maximum Rip Capacity To Left Of Blade10¹/₂"
 Distance From Front Of Table To Center Of Blade16"
 Distance From Front Of Table To Front Of Blade.....11"
 Maximum Width Of Dado Cut1³/₁₆"

Motor:

TypeTEFC Capacitor Start Induction
 Horsepower2 HP
 Phase/CycleSingle-Phase/60 Hz
 Voltage110/220V
 Prewired Voltage220V
 Amps24/12A
 RPM3450 RPM
 Power TransferBelt Drive
 Power Switch.....On/Off Push Button

Arbor Shaft:

Dimensions⁵/₈" Diameter x 1¹/₄" Long
 Speed4250 RPM

Features:

.....Table Inserts For Standard & Dado Cutting
4" Dust Hood

Specifications, while deemed accurate, are not guaranteed.

7/2003

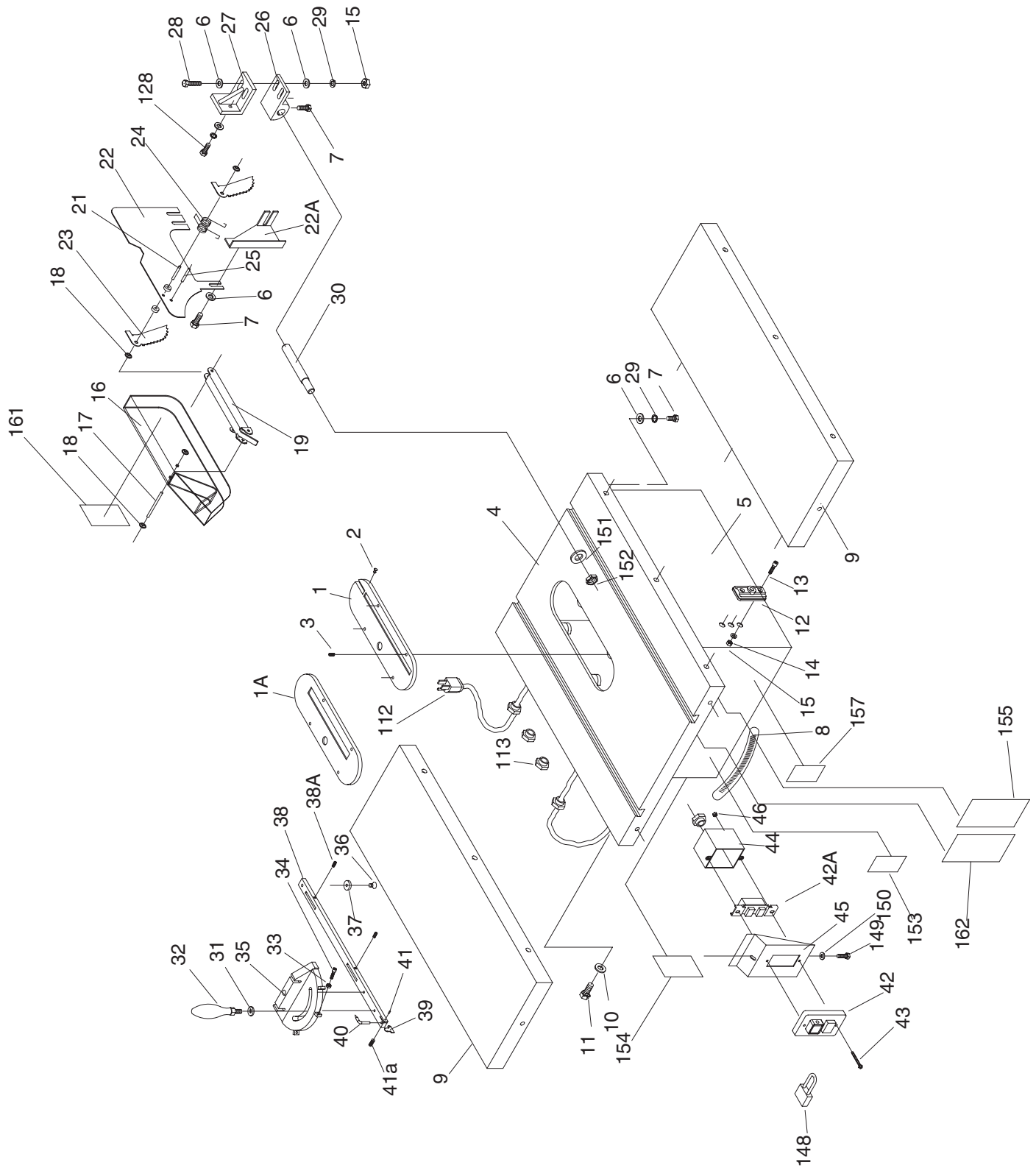

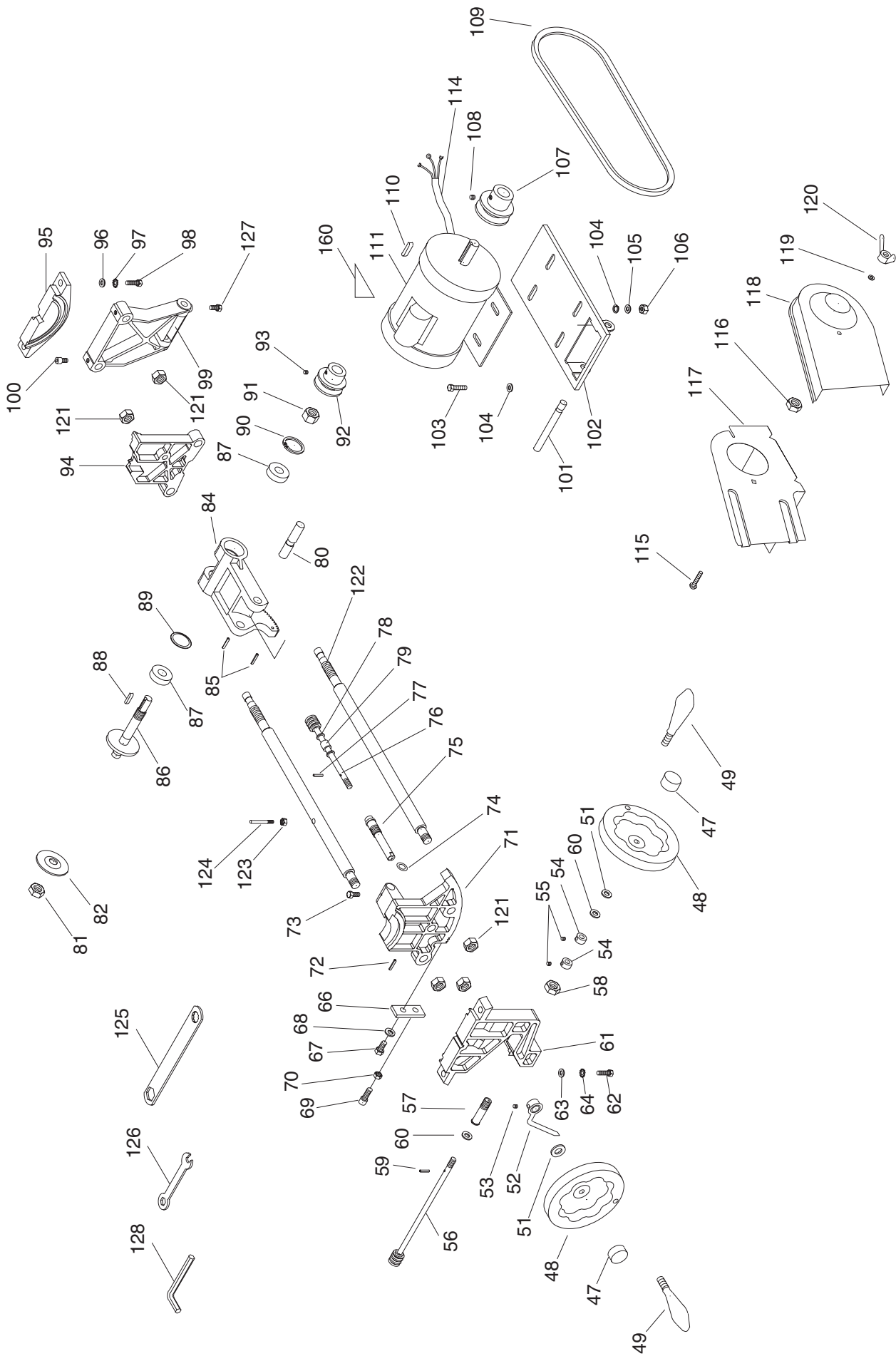

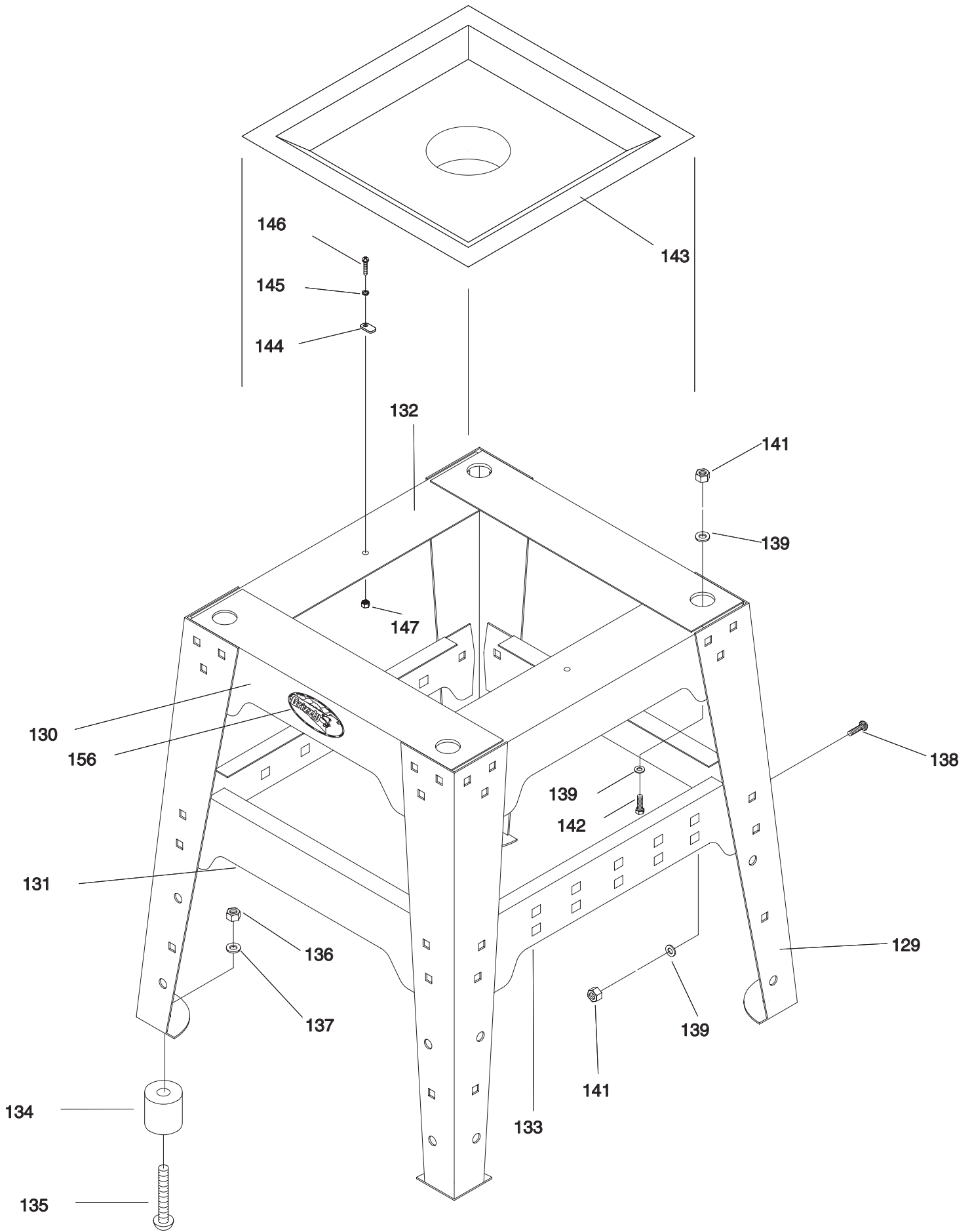

REF	PART #	DESCRIPTION
1A	P0444001A	DADO TABLE INSERT
1	P0444001	TABLE INSERT
2	P0444002	BUMPER
3	PSS04	SETSCREW 1/4-20 X 5/16"
4	P0444004	TABLE
5	P0444005	CABINET
6	PW07	FLAT WASHER 5/16"
7	PB32	HEX BOLT 5/16-18 X 5/8"
8	P0444008	SCALE
9	P0444009	EXTENSION WING - SHEET
9	P0444Z009	EXTENSION WING - CAST IRON
10	PLW05	LOCK WASHER 7/16"
11	PB90	HEX BOLT 7/16-14 X 1 1/4"
12	P0444012	BEARING BRACKET
13	PS35	PHLP HD SCR 5/16-18 X 3/4"
14	PW07	FLAT WASHER 5/16"
15	PN02	HEX NUT 5/16-18
16	P0444016	BLADE GUARD
17	P0444017	PIN 6 X 48
18	P0444018	SPEED NUT
19	P0444019	SUPPORTING ARM
21	P0444021	PIN 6 X 30
22	P0444022	SPLITTER
22A	P0444022A	MOUNT
23	P0444023	ANTI-KICKBACK
24	P0444024	ANTI-KICKBACK SPRING
25	P0444025	ROLL PIN 8 X 20
26	P0444026	BRACKET
27	P0444027	BRACKET
28	PB12	HEX BOLT 5/16-18 X 1 1/4"
29	PLW01	LOCK WASHER 5/16"
30	P0444030	GUARD SUPPORT SHAFT
31	PW07	FLAT WASHER 5/16"
32	P0444032	HAND KNOB
33	PN14	HEX NUT 8-32
34	PS21	PHLP HD SCR 8-32 X 3/4"
35	P0444035	MITER GAUGE BODY
36	PFH09	FLAT HD SCR 1/4-20 X 5/16"
37	P0444037	SLIDING BLOCK
38	P0444038	MITER BAR
38A	PSS34	SETSCREW 10-24 X 5/8"
39	P0444039	STOP LINK
40	P0444040	POINTER
41	PRP14M	ROLL PIN 3 X 6
41A	PSS11	SETSCREW 1/4-20 X 1/4"
42	P0444042	SWITCH BOX WITH 2 BUTTONS
43	PS10	PHLP HD SCR 10-24 X 1 1/2"
44	P0444044	SWITCH BOX
45	P0444045	SWITCH FIXING PLATE
46	PN07	HEX NUT 10-24
47	PSW03-1	KNOB
48	P0444048	HANDWHEEL

REF	PART #	DESCRIPTION
49	P0444049	HANDWHEEL HANDLE
51	PW02	FLAT WASHER 3/8"
52	P0444052	POINTER
53	PSS11	SETSCREW 1/4-20 X 1/4"
54	P0444054	SET COLLAR
55	PSS11	SETSCREW 1/4-20 X 1/4"
56	P0444056	TILT SHAFT
57	P0444057	ECCENTRIC
58	P0444058	HEX NUT 5/16-20
59	P0444059	ROLL PIN 3.5 X 20
60	P0444060	FIBER WASHER
61	P0444061	FRONT BRACKET
62	PB12	HEX BOLT 5/16-18 X 1 1/4"
63	PW07	FLAT WASHER 5/16"
64	PLW01	LOCK WASHER 5/16"
66	P0444066	STOP BLOCK
67	PB05	HEX BOLT 1/4-20 X 3/4"
68	PW06	FLAT WASHER 1/4"
69	PSS16	SETSCREW 1/4-20 X 1 1/2"
70	PN05	HEX NUT 1/4-20
71	P0444071	FRONT TRUNNION
72	PRP49M	ROLL PIN 5 X 25
73	PB32	HEX BOLT 5/16-18 X 5/8"
74	P0444074	WAVE WASHER
75	P0444075	ECCENTRIC
76	P0444076	ELEVATING SHAFT
77	P0444077	ROLL PIN 3.5 X 20
78	P0444078	FIBER WASHER
79	P0444079	SPACER
80	P0444080	ARBOR BRACKET SHAFT
81	P0444081	ARBOR NUT
82	P0444082	FLANGE
83	P0444083	BLADE OPTIONAL
84	P0444084	ARBOR BRACKET
85	PRP49M	ROLL PIN 5 X 25
86	P0444086	ARBOR
87	P6203	BALL BEARING 6203ZZ
88	PK23M	KEY 5 X 5 X 25
89	P0444089	LOADING SPRING
90	PR23M	INT RETAINING RING 40MM
91	P0444091	JAM NUT 5/8-24
92	P0444092	ARBOR PULLEY
93	PSS05	SETSCREW 5/16-18 X 1/4"
94	P0444094	REAR TRUNNION
95	P0444095	REAR TRUNNION BRACKET
96	PW07	FLAT WASHER 5/16"
97	PLW01	LOCK WASHER 5/16"
98	PB03	HEX BOLT 5/16-18 X 1
99	P0444099	MOTOR BRACKET
100	PSS17	SETSCREW 5/16-18 X 5/16"
101	P0444101	MOTOR PLATE ROD
102	P0444102	MOTOR PLATE

REF	PART #	DESCRIPTION
103	PB03	HEX BOLT 5/16-18 X 1
104	PW07	FLAT WASHER 5/16"
105	PLW01	LOCK WASHER 5/16"
106	PN02	HEX NUT 5/16-18
107	P0444107	MOTOR PULLEY
108	PSS11	SETSCREW 1/4-20 X 1/4"
109	P0444109	V-BELT 3VX-470
110	PK23M	KEY 5 X 5 X 25
111	P0444111	MOTOR 1.5 HP (G0444)
111	P0444Z111	MOTOR 2 HP (G0444Z)
112	PWRCRD110L	CORD 110V, LONG W/PLUG
112	PWRCRD220L	CORD 220V, LONG W/PLUG
113	P0444113	NYLON CLAMP
114	PWRCRD110S	POWER CORD 110V, SHORT
114	PWRCRD220S	POWER CORD 220V, SHORT
115	PCB04	CARRIAGE BOLT 1/4-20 X 1 3/4"
116	P0444116	SPEED NUT 1/4"
117	P0444117	GUARD PLATE
118	P0444118	GUARD COVER
119	PW06	FLAT WASHER 1/4"
120	PWN02	WING NUT 1/4-20
121	PN09	HEX NUT 5/8-18
122	P0444122	TIE-ROD
123	PN08	HEX NUT 3/8-16
124	P0444124	ADJUSTABLE STOP 3/8-16 X 2
125	PWR23	23MM WRENCH
126	PWR1213	12MM X 13MM WRENCH
127	PB05	HEX BOLT 1/4-20 X 3/4"
128	PAW02M	ALLEN WRENCH 2MM
128B	PAW04M	ALLEN WRENCH 4MM
128A	PAW03M	ALLEN WRENCH 3MM
129	P0444129	FOOT STAND

REF	PART #	DESCRIPTION
130	P0444130	TOP SHORT BRACKET
131	P0444131	BOTTOM SHORT BRACKET
132	P0444132	TOP LONG BRACKET
133	P0444133	BOTTOM LONG BRACKET
134	P0444134	RUBBER FEET
135	PS19	PHLP HD SCR 1/4-20 X 1
136	PN05	HEX NUT 1/4-20
137	PW06	FLAT WASHER 1/4"
138	PCB01	CARRIAGE BOLT 5/16-18 X 5/8"
139	PW07	FLAT WASHER 5/16"
141	PN02	HEX NUT 5/16-18
142	PB03	HEX BOLT 5/16-18 X 1
143	P0444143	DUST HOOD
144	P0444144	PLATE
145	PTLW01	EXT TOOTH WASHER #10
146	PS22	PHLP HD SCR 10-24 X 5/8"
147	PN07	HEX NUT 10-24
148	P0444148	SAFETY PADLOCK
149	PB05	HEX BOLT 1/4-20 X 3/4"
150	PW06	FLAT WASHER 1/4"
151	PW01	FLAT WASHER 1/2"
152	PN06	HEX NUT 1/2-12
153	P0444153	SAFETY GLASSES LABEL
154	P0444154	UNPLUG WARNING LABEL
155	P0444155	WARNING LABEL
156	P0444156	GRIZZLY CAST LOGO
157	P0444157	READ MANUAL LABEL
160	P0444160	ELECTRICITY LABEL
161	P0444161	BLADE GUARD LABEL
162	P0444162	MACHINE ID LABEL (G0444)
162	P0444Z162	MACHINE ID LABEL (G0444Z)

Troubleshooting

SYMPTOM	POSSIBLE CAUSE	CORRECTIVE ACTION
Motor will not start.	<ol style="list-style-type: none"> 1. Low voltage. 2. Open circuit in motor or loose connections. 	<ol style="list-style-type: none"> 1. Check power line for proper voltage. 2. Inspect all lead connections on motor for loose or open connections.
Motor will not start; fuses or circuit breakers blow.	<ol style="list-style-type: none"> 1. Short circuit in line cord or plug. 2. Short circuit in motor or loose connections. 3. Incorrect fuses or circuit breakers in power line. 	<ol style="list-style-type: none"> 1. Inspect cord or plug for damaged insulation and shorted wires. 2. Inspect all connections on motor for loose or shorted terminals or worn insulation. 3. Install correct fuses or circuit breakers.
Motor overheats.	<ol style="list-style-type: none"> 1. Motor overloaded. 2. Air circulation through the motor restricted. 	<ol style="list-style-type: none"> 1. Reduce load on motor. 2. Clean out motor to provide normal air circulation.
Motor stalls (resulting in blown fuses or tripped circuit).	<ol style="list-style-type: none"> 1. Short circuit in motor or loose connections. 2. Low voltage. 3. Incorrect fuses or circuit breakers in power line. 4. Motor overloaded. 	<ol style="list-style-type: none"> 1. Inspect connections on motor for loose or shorted terminals or worn insulation. 2. Correct the low voltage conditions. 3. Install correct fuses or circuit breakers. 4. Reduce load on motor.
Machine slows when operating.	<ol style="list-style-type: none"> 1. Applying too much pressure to workpiece. 2. Belts loose. 	<ol style="list-style-type: none"> 1. Feed workpiece slower. 2. Tighten belts.
Loud, repetitious noise coming from machine.	<ol style="list-style-type: none"> 1. Pulley setscrews or keys are missing or loose. 2. Motor fan is hitting the cover. 3. V-belts are defective 	<ol style="list-style-type: none"> 1. Inspect keys and setscrews. Replace or tighten if necessary. 2. Tighten fan or shim cover. 3. Replace V-belts.
Blade is not square w/miter slot or fence is not square to blade.	<ol style="list-style-type: none"> 1. Blade is warped. 2. Table top is not parallel to blade. 3. Fence is not parallel to blade. 	<ol style="list-style-type: none"> 1. Replace blade. 2. Make table parallel to blade. 3. Make fence parallel to blade.
Fence hits table top when sliding on to the table.	<ol style="list-style-type: none"> 1. Front rail is bolted too low on table. 2. Rear rail is bolted too low on the table. 	<ol style="list-style-type: none"> 1. Raise front rail. 2. Raise rear rail.
Blade does not reach 90°.	<ol style="list-style-type: none"> 1. 90° stop bolt is out of adjustment. 2. Pointer bracket is hitting before the blade reaches 90°. 	<ol style="list-style-type: none"> 1. Adjust 90° stop bolt. 2. File down the right side of the pointer bracket until the blade can reach 90°.
Blade hits insert at 45°.	<ol style="list-style-type: none"> 1. Hole in insert is inadequate. 2. Table out of alignment. 3. Blade position is incorrect. 	<ol style="list-style-type: none"> 1. File or mill the hole in the insert. 2. Align table. 3. Adjust blade position.
Blade will not go beneath table surface.	<ol style="list-style-type: none"> 1. Table top too low. 	<ol style="list-style-type: none"> 1. Raise table top w/washers.
Hand wheels won't turn.	<ol style="list-style-type: none"> 1. Hand wheel key is inserted too far. 2. Bullets are wedged. 3. Roll pin or setscrew in worm gear is contacting geared trunnion. 	<ol style="list-style-type: none"> 1. Remove hand wheel and adjust key. 2. Remove hand wheel and adjust bullets. 3. Inspect roll pins and setscrews in the worm gear. Tighten if necessary.



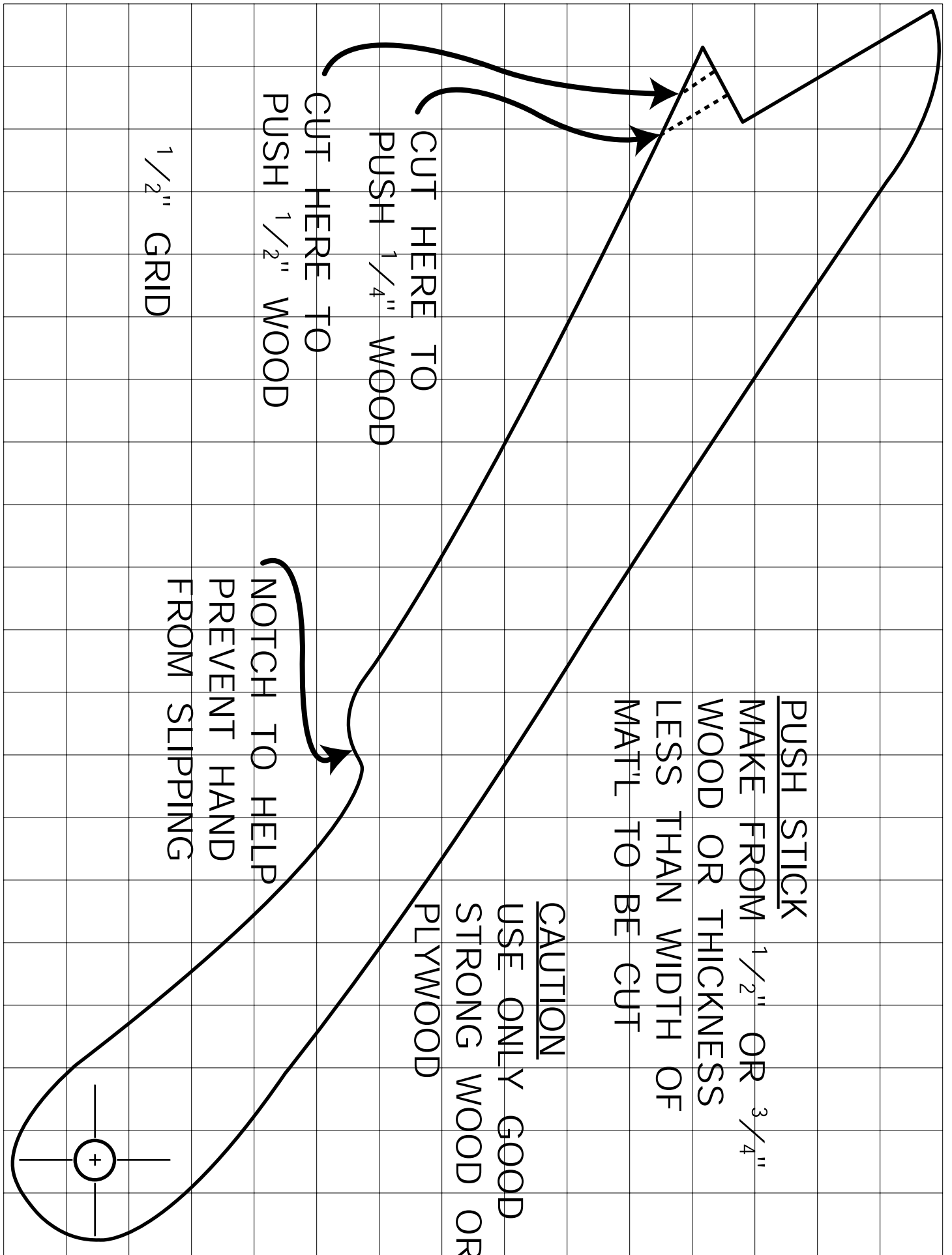

PUSH STICK
 MAKE FROM $\frac{1}{2}$ " OR $\frac{3}{4}$ "
 WOOD OR THICKNESS
 LESS THAN WIDTH OF
 MAT'L TO BE CUT

CAUTION
 USE ONLY GOOD
 STRONG WOOD OR
 PLYWOOD

NOTCH TO HELP
 PREVENT HAND
 FROM SLIPPING

CUT HERE TO
 PUSH $\frac{1}{4}$ " WOOD
 CUT HERE TO
 PUSH $\frac{1}{2}$ " WOOD

$\frac{1}{2}$ " GRID

G0444 & G0444Z Wiring Diagrams

⚠ DANGER

Disconnect power from machine before performing any electrical service. Failure to do this will result in a shock hazard, leading to injury or death.

NOTE: THE WIRES FROM THE POWER SUPPLY, EXCEPT THE GREEN GROUND WIRE, ARE INTERCHANGABLE, THEREFORE COLORS ARE NOT SPECIFIED.

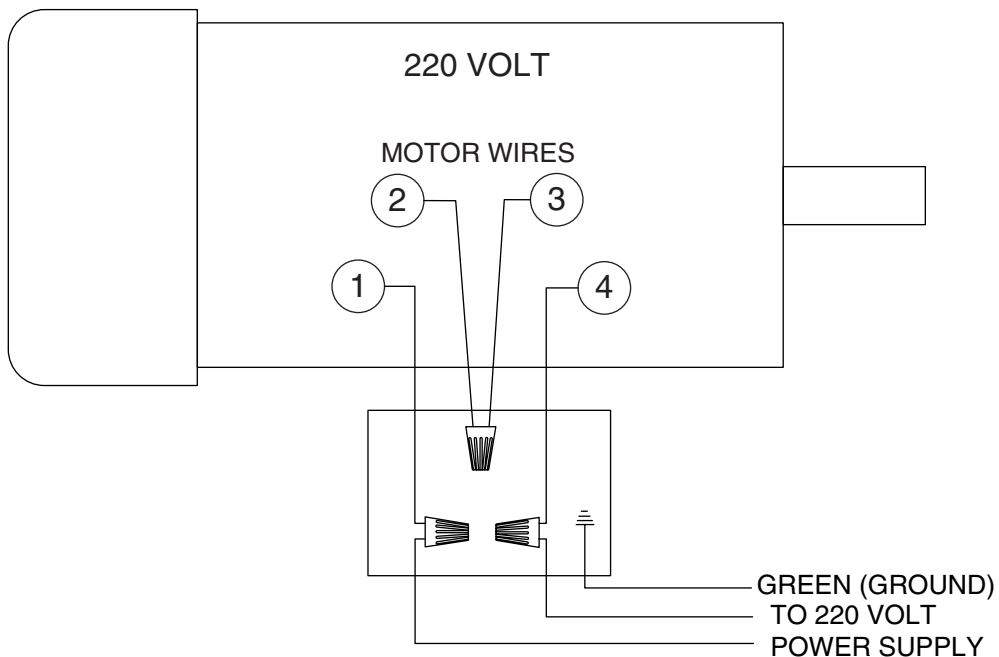
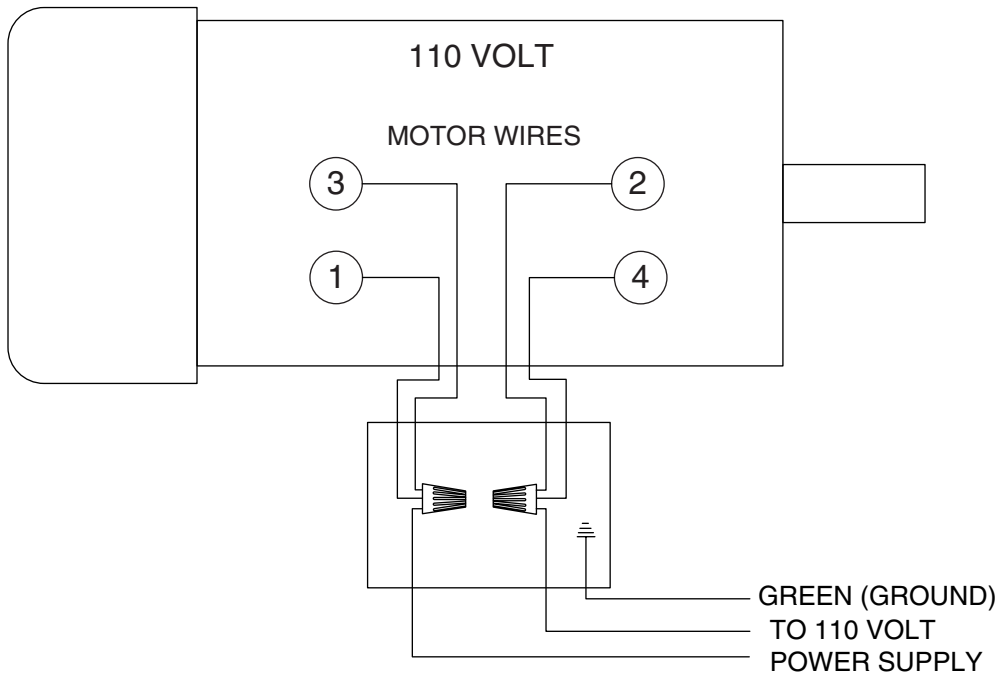

Warranty & Returns

Grizzly Industrial, Inc. warrants every product it sells for a period of **1 year** to the original purchaser from the date of purchase. This warranty does not apply to defects due directly or indirectly to misuse, abuse, negligence, accidents, repairs or alterations or lack of maintenance. This is Grizzly's sole written warranty and any and all warranties that may be implied by law, including any merchantability or fitness, for any particular purpose, are hereby limited to the duration of this written warranty. We do not warrant or represent that the merchandise complies with the provisions of any law or acts unless the manufacturer so warrants. In no event shall Grizzly's liability under this warranty exceed the purchase price paid for the product and any legal actions brought against Grizzly shall be tried in the State of Washington, County of Whatcom.

We shall in no event be liable for death, injuries to persons or property or for incidental, contingent, special, or consequential damages arising from the use of our products.

To take advantage of this warranty, contact us by mail or phone and give us all the details. We will then issue you a "Return Number," which must be clearly posted on the outside as well as the inside of the carton. We will not accept any item back without this number. Proof of purchase must accompany the merchandise.

The manufacturers reserve the right to change specifications at any time because they constantly strive to achieve better quality equipment. We make every effort to ensure that our products meet high quality and durability standards and we hope you never need to use this warranty.

Please feel free to write or call us if you have any questions about the machine or the manual.

Thank you again for your business and continued support. We hope to serve you again soon.



WARRANTY CARD

Name _____
Street _____
City _____ State _____ Zip _____
Phone Number _____ E-Mail _____ FAX _____
MODEL # _____ Serial # _____ Order # _____

The following information is given on a voluntary basis. It will be used for marketing purposes to help us develop better products and services. Of course, all information is strictly confidential.

1. How did you learn about us?
- Advertisement Friend
 Catalog Card Deck
 World Wide Web
 Other _____
2. Which of the following magazines do you subscribe to.
- American Woodworker Practical Homeowner
 Cabinetmaker Shop Notes
 Family Handyman Today's Homeowner
 Fine Homebuilding WOOD
 Fine Woodworking Wooden Boat
 Home Handyman Woodshop News
 Journal of Light Construction Woodsmith
 Old House Journal Woodwork
 Popular Mechanics Woodworker
 Popular Science Woodworker's Journal
 Popular Woodworking Workbench
 Other _____
3. Which of the following woodworking/remodeling shows do you watch?
- Backyard America The New Yankee Workshop
 Home Time This Old House
 The American Woodworker Woodwright's Shop
 Other _____
4. What is your annual household income?
- \$20,000-\$29,999 \$60,000-\$69,999
 \$30,000-\$39,999 \$70,000-\$79,999
 \$40,000-\$49,999 \$80,000-\$89,999
 \$50,000-\$59,999 \$90,000 +
5. What is your age group?
- 20-29 50-59
 30-39 60-69
 40-49 70 +
6. How long have you been a woodworker?
- 0 - 2 Years 8 - 20 Years
 2 - 8 Years 20+ Years
7. How would you rank your woodworking skills?
- Simple Advanced
 Intermediate Master Craftsman
8. What stationary woodworking tools do you own? Check all that apply.
- Air Compressor Panel Saw
 Bandsaw Planer
 Drill Press Power Feeder
 Drum Sander Radial Arm Saw
 Dust Collector Shaper
 Horizontal Boring Machine Spindle Sander
 Jointer Table Saw
 Lathe Vacuum Veneer Press
 Mortiser Wide Belt Sander
 Other _____
9. How many of your woodworking machines are Grizzly? _____
10. Which benchtop tools do you own? Check all that apply.
- 1" x 42" Belt Sander 6" - 8" Grinder
 5" - 8" Drill Press Mini Lathe
 8" Table Saw 10" - 12" Thickness Planer
 8" - 10" Bandsaw Scroll Saw
 Disc/Belt Sander Spindle/Belt Sander
 Mini Jointer
 Other _____
11. How many of the machines checked above are Grizzly? _____
12. Which portable/hand held power tools do you own? Check all that apply.
- Belt Sander Orbital Sander
 Biscuit Joiner Palm Sander
 Circular Saw Portable Planer
 Detail Sander Saber Saw
 Drill/Driver Reciprocating Saw
 Miter Saw Router
 Other _____
13. What machines/supplies would you like Grizzly Industrial to carry?

14. What new accessories would you like Grizzly Industrial to carry?

15. What other companies do you purchase your tools and supplies from?

16. Do you think your purchase represents good value?
 Yes No
17. Would you recommend Grizzly Industrial to a friend?
 Yes No
18. Would you allow us to use your name as a reference for Grizzly customers in your area? **Note: We never use names more than three times.**
 Yes No
19. Comments: _____

CUT ALONG DOTTED LINE

FOLD ALONG DOTTED LINE



Place
Stamp
Here



GRIZZLY INDUSTRIAL, INC.
P.O. BOX 2069
BELLINGHAM, WA 98227-2069



FOLD ALONG DOTTED LINE

Send a Grizzly Catalog to a friend:

Name _____
Street _____
City _____ State _____ Zip _____

TAPE ALONG EDGES--PLEASE DO NOT STAPLE

grizzly.com

TOOL WEBSITE

Buy Direct and Save with Grizzly® – Trusted, Proven and a Great Value!

*Visit Our Website Today And Discover Why
Grizzly® Is The Industry Leader!*

- SECURE ORDERING
- ORDERS SHIPPED WITHIN 24 HOURS
- E-MAIL RESPONSE WITHIN ONE HOUR

-OR-

Call Today For A **FREE**
Full Color Catalog

1-800-523-4777



Free Manuals Download Website

<http://myh66.com>

<http://usermanuals.us>

<http://www.somanuals.com>

<http://www.4manuals.cc>

<http://www.manual-lib.com>

<http://www.404manual.com>

<http://www.luxmanual.com>

<http://aubethermostatmanual.com>

Golf course search by state

<http://golfingnear.com>

Email search by domain

<http://emailbydomain.com>

Auto manuals search

<http://auto.somanuals.com>

TV manuals search

<http://tv.somanuals.com>