

Grizzly **Industrial, Inc.**®

MODEL T26417/T26418 **OSCILLATING SPINDLE SANDER** **OWNER'S MANUAL** *(For models manufactured since 11/13)*



COPYRIGHT © NOVEMBER, 2013 BY GRIZZLY INDUSTRIAL, INC.
**WARNING: NO PORTION OF THIS MANUAL MAY BE REPRODUCED IN ANY SHAPE
OR FORM WITHOUT THE WRITTEN APPROVAL OF GRIZZLY INDUSTRIAL, INC.**
#DM16072 PRINTED IN CHINA

V1.11.13



WARNING!

This manual provides critical safety instructions on the proper setup, operation, maintenance, and service of this machine/tool. Save this document, refer to it often, and use it to instruct other operators.

Failure to read, understand and follow the instructions in this manual may result in fire or serious personal injury—including amputation, electrocution, or death.

The owner of this machine/tool is solely responsible for its safe use. This responsibility includes but is not limited to proper installation in a safe environment, personnel training and usage authorization, proper inspection and maintenance, manual availability and comprehension, application of safety devices, cutting/sanding/grinding tool integrity, and the usage of personal protective equipment.

The manufacturer will not be held liable for injury or property damage from negligence, improper training, machine modifications or misuse.



WARNING!

Some dust created by power sanding, sawing, grinding, drilling, and other construction activities contains chemicals known to the State of California to cause cancer, birth defects or other reproductive harm. Some examples of these chemicals are:

- **Lead from lead-based paints.**
- **Crystalline silica from bricks, cement and other masonry products.**
- **Arsenic and chromium from chemically-treated lumber.**

Your risk from these exposures varies, depending on how often you do this type of work. To reduce your exposure to these chemicals: Work in a well ventilated area, and work with approved safety equipment, such as those dust masks that are specially designed to filter out microscopic particles.

Table of Contents

INTRODUCTION	2	SECTION 5: ACCESSORIES	24
Contact Info.....	2	SECTION 6: MAINTENANCE	26
Manual Accuracy	2	Schedule	26
Identification.....	3	Cleaning.....	26
SECTION 1: SAFETY	8	Lubrication	26
Safety Instructions for Machinery	8	SECTION 7: SERVICE	27
Additional Safety for Spindle Sanders	10	Troubleshooting	27
SECTION 2: POWER SUPPLY	11	SECTION 8: WIRING	28
Availability	11	Wiring Safety Instructions	28
Full-Load Current Rating.....	11	T26417 Wiring Diagram.....	29
110V Circuit Requirements	11	T26418 Wiring Diagram.....	30
Grounding & Plug Requirements	12	SECTION 9: PARTS	31
Extension Cords.....	12	T26417 Main.....	31
SECTION 3: SETUP	13	T26417 Oscillator Assembly	33
Unpacking	13	T26417 Machine Labels & Cosmetics	34
Needed for Setup.....	13	T26418 Main.....	35
Inventory	14	T26418 Oscillator Assembly.....	37
Cleanup.....	15	T26418 Machine Labels & Cosmetics	38
Site Considerations.....	15	WARRANTY & RETURNS	41
Mounting T26417 to Bench.....	16		
Anchoring T26418 to Floor	16		
Assembly	17		
Dust Collection.....	17		
Test Run	18		
SECTION 4: OPERATIONS	19		
Operation Overview	19		
Installing Sanding Drum/Sleeve.....	20		
Installing Sanding Drums	20		
Changing Spindle Sanding Sleeve	21		
Tilting Table	22		
Table Inserts	23		
Sanding.....	23		

INTRODUCTION

Contact Info

We stand behind our machines. If you have any questions or need help, use the information below to contact us. Before contacting, please get the serial number and manufacture date of your machine. This will help us help you faster.

Grizzly Technical Support
1203 Lycoming Mall Circle
Muncy, PA 17756
Phone: (570) 546-9663
Email: techsupport@grizzly.com

We want your feedback on this manual. What did you like about it? Where could it be improved? Please take a few minutes to give us feedback.

Grizzly Documentation Manager
P.O. Box 2069
Bellingham, WA 98227-2069
Email: manuals@grizzly.com

Manual Accuracy

We are proud to provide a high-quality owner's manual with your new machine!

We made every effort to be exact with the instructions, specifications, drawings, and photographs contained inside. Sometimes we make mistakes, but our policy of continuous improvement also means that **sometimes the machine you receive will be slightly different than what is shown in the manual.**

If you find this to be the case, and the difference between the manual and machine leaves you confused about a procedure, check our website for an updated version. We post current manuals and manual updates for free on our website at **www.grizzly.com.**

Alternatively, you can call our Technical Support for help. Before calling, please write down the **Manufacture Date** and **Serial Number** stamped into the machine ID label (see below). This information helps us determine if updated documentation is available for your machine.

		MODEL GXXXX	
		MACHINE NAME	
SPECIFICATIONS		▲ WARNING!	
Motor:		To reduce risk of serious injury when using this machine:	
Specification:		Read manual before operation.	
Specification:		Wear safety glasses and respirator.	
Specification:		Ensure safety is correctly adjusted/setup and	
Weight:		power is connected to grounded circuit before starting.	
		4. Make sure the motor has stopped and disconnect	
		power before adjustments, maintenance, or service.	
		5. DO NOT expose to rain or dampness.	
		6. DO NOT modify this machine in any way.	
		7.	
		8.	
		9. Do not use while impaired by drugs or alcohol.	
		10. Maintain machine carefully to prevent accidents.	
		Manufactured for Grizzly in Taiwan	

Manufacture Date []

Serial Number []



Identification

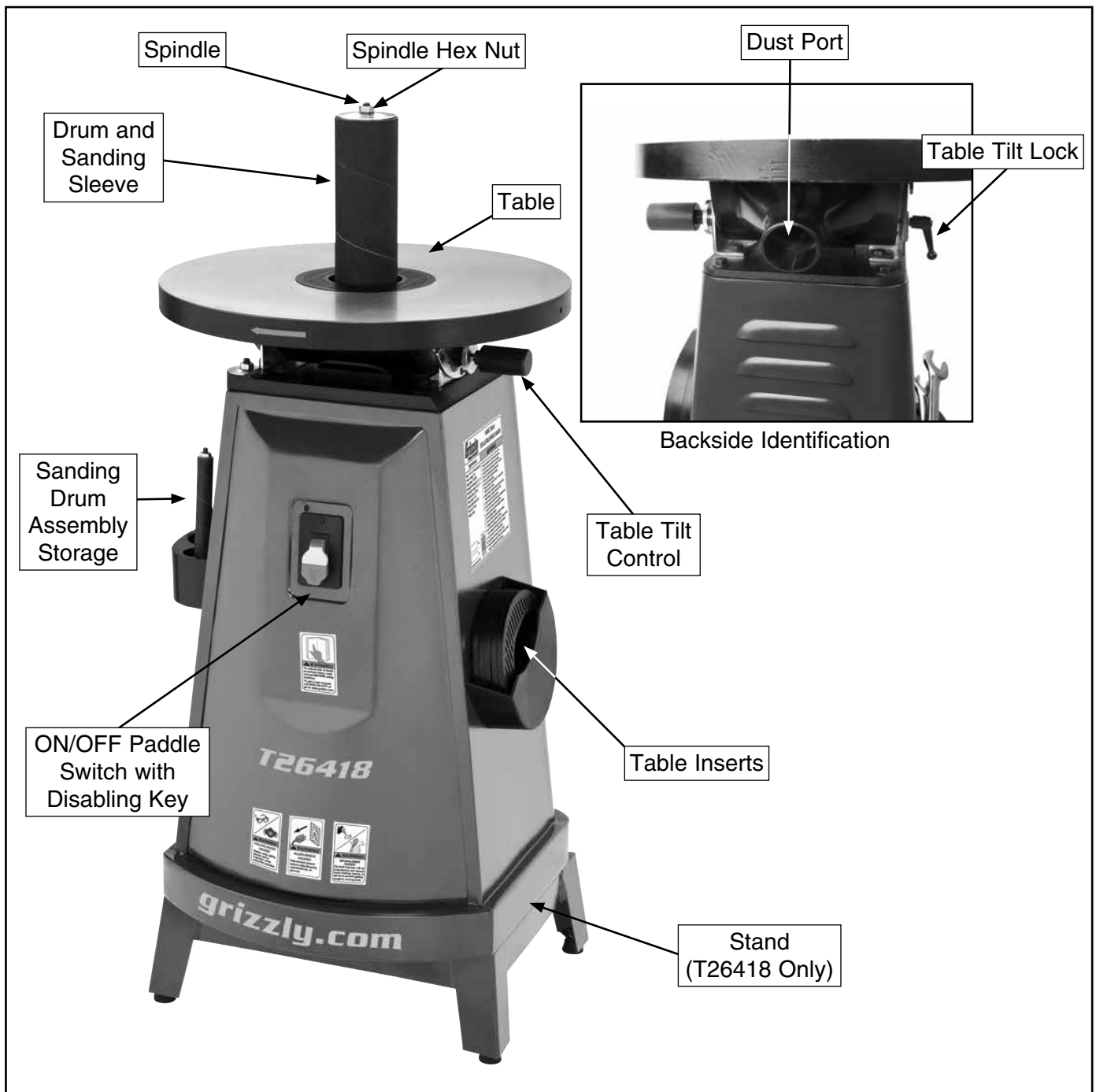

Figure 1. Identification.

	<p>⚠ WARNING</p> <p>To reduce your risk of serious injury, read this entire manual BEFORE using machine.</p>
--	--





MACHINE DATA SHEET

Customer Service #: (570) 546-9663 · To Order Call: (800) 523-4777 · Fax #: (800) 438-5901

MODEL T26417 BENCHTOP OSCILLATING SANDER

Product Dimensions:

Weight..... 73 lbs.
 Width (side-to-side) x Depth (front-to-back) x Height..... 15 x 15 x 24 in.
 Footprint (Length x Width)..... 15 x 15 in.

Shipping Dimensions:

Type..... Cardboard Box
 Content..... Machine
 Weight..... 78 lbs.
 Length x Width x Height..... 18 x 18 x 20 in.
 Must Ship Upright..... Yes

Electrical:

Power Requirement..... 110V, Single-Phase, 60Hz
 Prewired Voltage..... 110V
 Full-Load Current Rating..... 3.4A
 Minimum Circuit Size..... 15A
 Power Cord Included..... Yes
 Power Cord Length..... 6 ft.
 Power Cord Gauge..... 16 AWG
 Plug Included..... Yes
 Included Plug Type..... 5-15
 Switch Type..... Paddle Safety Switch w/ Removable Key

Motors:

Main

Type..... TEFC Induction
 Horsepower..... 1/2 HP
 Phase..... Single-Phase
 Amps..... 3.4A
 Speed..... 1725 RPM
 Power Transfer..... Direct

Main Specifications:

Spindle Sander Info

Sanding Drum Diameters..... 3/4, 1, 2 in.
 Sanding Drum Length..... 3-1/2, 4-1/2, 5-1/2 in.
 Spindle Speed..... 1725 RPM
 Spindle Oscillation..... 29 OPM
 Stroke Length..... 15/16 in.
 Table Length..... 15 in.
 Table Width..... 15 in.
 Table Thickness..... 1-1/4 in.
 Table-to-Floor Height..... 19 in.
 Spindle Shaft Diameter..... 10, 16 mm
 Number of Table Inserts..... 4
 Included Sanding Sleeve Grit Size..... 100 Grit
 Table Tilt..... 45 deg.



Construction Materials

Base..... Formed Steel
Stand..... Formed Steel
Table..... Cast Iron
Paint..... Powder Coated

Other Related Info

Number of Dust Ports..... 1
Dust Port Size..... 2 in.

Other Specifications:

Country Of Origin China
Warranty 1 Year
Approximate Assembly & Setup Time 15 Minutes
Serial Number Location Machine ID Label
Sound Rating 83-85 dB

Features:

- 45 degree table tilt
- Easy-access sanding drum holder on side of machine
- Firm grip rubber feet
- Cast iron work table

Accessories Included:

- Three sanding drums
- Wrenches for changing spindles





MACHINE DATA SHEET

Customer Service #: (570) 546-9663 · To Order Call: (800) 523-4777 · Fax #: (800) 438-5901

MODEL T26418 FLOOR-MODEL OSCILLATING SANDER

Product Dimensions:

Weight..... 126 lbs.
Width (side-to-side) x Depth (front-to-back) x Height..... 20-1/4 x 19-5/8 x 45-1/2 in.
Footprint (Length x Width)..... 20-1/4 x 19-5/8 in.

Shipping Dimensions:

Carton #1

Type..... Cardboard Box
Content..... Machine
Weight..... 137 lbs.
Length x Width x Height..... 22 x 22 x 32 in.
Must Ship Upright..... Yes

Carton #2

Type..... Cardboard Box
Content..... Stand
Weight..... 6 lbs.
Length x Width x Height..... 20 x 20 x 7 in.

Electrical:

Power Requirement..... 110V, Single-Phase, 60Hz
Prewired Voltage..... 110V
Full-Load Current Rating..... 6.9A
Minimum Circuit Size..... 15A
Power Cord Included..... Yes
Power Cord Length..... 6 ft.
Power Cord Gauge..... 16 AWG
Plug Included..... Yes
Included Plug Type..... 5-15
Switch Type..... Paddle Safety Switch w/ Removable Key

Motors:

Main

Type..... TEFC Induction
Horsepower..... 1 HP
Phase..... Single-Phase
Amps..... 6.9A
Speed..... 1725 RPM
Power Transfer..... Direct



Spindle Sander Info

Sanding Drum Diameters.....	3/4, 2, 3 in.
Sanding Drum Length.....	4-1/2, 9, 9 in.
Spindle Speed.....	1725 RPM
Spindle Oscillation.....	52 OPM
Stroke Length.....	1-3/16 in.
Table Length.....	19-11/16 in.
Table Width.....	19-11/16 in.
Table Thickness.....	1-5/16 in.
Table-to-Floor Height.....	36-3/4 in.
Spindle Shaft Diameter.....	10, 16 mm
Number of Table Inserts.....	6
Included Sanding Sleeve Grit Size.....	100 Grit
Table Tilt.....	45 deg.

Construction Materials

Base.....	Formed Steel
Stand.....	Formed Steel
Table.....	Cast Iron
Paint.....	Powder Coated

Other Related Info

Number of Dust Ports.....	1
Dust Port Size.....	2 in.

Other Specifications:

Country Of Origin	China
Warranty	1 Year
Approximate Assembly & Setup Time	25 Minutes
Serial Number Location	Machine ID Label
Sound Rating	83-85 dB

Features:

- 45 degree table tilt
- Sanding drum holder on side of machine
- Cast iron work table
- Rubber feet

Accessories Included:

- Three sanding drums
- Wrenches for changing spindles



SECTION 1: SAFETY

For Your Own Safety, Read Instruction Manual Before Operating This Machine

The purpose of safety symbols is to attract your attention to possible hazardous conditions. This manual uses a series of symbols and signal words intended to convey the level of importance of the safety messages. The progression of symbols is described below. Remember that safety messages by themselves do not eliminate danger and are not a substitute for proper accident prevention measures. Always use common sense and good judgment.



Indicates an imminently hazardous situation which, if not avoided, **WILL** result in death or serious injury.



Indicates a potentially hazardous situation which, if not avoided, **COULD** result in death or serious injury.



Indicates a potentially hazardous situation which, if not avoided, **MAY** result in minor or moderate injury. It may also be used to alert against unsafe practices.

NOTICE

This symbol is used to alert the user to useful information about proper operation of the machine.

Safety Instructions for Machinery

WARNING

OWNER'S MANUAL. Read and understand this owner's manual **BEFORE** using machine.

TRAINED OPERATORS ONLY. Untrained operators have a higher risk of being hurt or killed. Only allow trained/supervised people to use this machine. When machine is not being used, disconnect power, remove switch keys, or lock-out machine to prevent unauthorized use—especially around children. Make workshop kid proof!

DANGEROUS ENVIRONMENTS. Do not use machinery in areas that are wet, cluttered, or have poor lighting. Operating machinery in these areas greatly increases the risk of accidents and injury.

MENTAL ALERTNESS REQUIRED. Full mental alertness is required for safe operation of machinery. Never operate under the influence of drugs or alcohol, when tired, or when distracted.

ELECTRICAL EQUIPMENT INJURY RISKS. You can be shocked, burned, or killed by touching live electrical components or improperly grounded machinery. To reduce this risk, only allow qualified service personnel to do electrical installation or repair work, and always disconnect power before accessing or exposing electrical equipment.

DISCONNECT POWER FIRST. Always disconnect machine from power supply **BEFORE** making adjustments, changing tooling, or servicing machine. This prevents an injury risk from unintended startup or contact with live electrical components.

EYE PROTECTION. Always wear ANSI-approved safety glasses or a face shield when operating or observing machinery to reduce the risk of eye injury or blindness from flying particles. Everyday eyeglasses are **NOT** approved safety glasses.



WARNING

WEARING PROPER APPAREL. Do not wear clothing, apparel or jewelry that can become entangled in moving parts. Always tie back or cover long hair. Wear non-slip footwear to avoid accidental slips, which could cause loss of workpiece control.

HAZARDOUS DUST. Dust created while using machinery may cause cancer, birth defects, or long-term respiratory damage. Be aware of dust hazards associated with each workpiece material, and always wear a NIOSH-approved respirator to reduce your risk.

HEARING PROTECTION. Always wear hearing protection when operating or observing loud machinery. Extended exposure to this noise without hearing protection can cause permanent hearing loss.

REMOVE ADJUSTING TOOLS. Tools left on machinery can become dangerous projectiles upon startup. Never leave chuck keys, wrenches, or any other tools on machine. Always verify removal before starting!

USE CORRECT TOOL FOR THE JOB. Only use this tool for its intended purpose—do not force it or an attachment to do a job for which it was not designed. Never make unapproved modifications—modifying tool or using it differently than intended may result in malfunction or mechanical failure that can lead to personal injury or death!

AWKWARD POSITIONS. Keep proper footing and balance at all times when operating machine. Do not overreach! Avoid awkward hand positions that make workpiece control difficult or increase the risk of accidental injury.

CHILDREN & BYSTANDERS. Keep children and bystanders at a safe distance from the work area. Stop using machine if they become a distraction.

GUARDS & COVERS. Guards and covers reduce accidental contact with moving parts or flying debris. Make sure they are properly installed, undamaged, and working correctly.

FORCING MACHINERY. Do not force machine. It will do the job safer and better at the rate for which it was designed.

NEVER STAND ON MACHINE. Serious injury may occur if machine is tipped or if the cutting tool is unintentionally contacted.

STABLE MACHINE. Unexpected movement during operation greatly increases risk of injury or loss of control. Before starting, verify machine is stable and mobile base (if used) is locked.

USE RECOMMENDED ACCESSORIES. Consult this owner's manual or the manufacturer for recommended accessories. Using improper accessories will increase the risk of serious injury.

UNATTENDED OPERATION. To reduce the risk of accidental injury, turn machine **OFF** and ensure all moving parts completely stop before walking away. Never leave machine running while unattended.

MAINTAIN WITH CARE. Follow all maintenance instructions and lubrication schedules to keep machine in good working condition. A machine that is improperly maintained could malfunction, leading to serious personal injury or death.

CHECK DAMAGED PARTS. Regularly inspect machine for any condition that may affect safe operation. Immediately repair or replace damaged or mis-adjusted parts before operating machine.

MAINTAIN POWER CORDS. When disconnecting cord-connected machines from power, grab and pull the plug—NOT the cord. Pulling the cord may damage the wires inside. Do not handle cord/plug with wet hands. Avoid cord damage by keeping it away from heated surfaces, high traffic areas, harsh chemicals, and wet/damp locations.

EXPERIENCING DIFFICULTIES. If at any time you experience difficulties performing the intended operation, stop using the machine! Contact our Technical Support at (570) 546-9663.



Additional Safety for Spindle Sanders

WARNING

FEED RATE. Never jam a workpiece against the sanding surface. This can cause the workpiece to kick back or damage the machine. Firmly hold the workpiece and ease it against the spindle using light pressure. Allow the machine to do the work—do not force the workpiece.

AVOIDING ENTANGLEMENT. Keep loose clothing articles such as sleeves, belts, or jewelry items away from the spindle. These items could get entangled in the spindle, resulting in serious personal injury. Never wear gloves when operating the spindle sander.

RESPIRATOR USE. Always use a respirator that is approved for wood dust when using this machine to reduce the risk of short and long term respiratory illness. A dust collector is not an adequate substitute.

WORKPIECE HANDLING. Hold the workpiece with both hands to maintain good control while sanding (or use an appropriate holding jig). This will reduce the likelihood of losing control of the workpiece and having it thrown from the machine.

SANDING SLEEVES. Worn or damaged sanding sleeves can tear apart and become entangled in the spindle or be thrown from the machine, resulting in personal injury or property damage. Promptly replace sanding sleeves if they become worn or damaged.

FOREIGN MATERIAL. Do not use stock with nails, staples, knots, and other imperfections that could be dislodged and thrown from the machine during sanding operations.

DUST COLLECTION. Never operate the sander without an adequate dust collection system in place and running. Proper dust collection reduces dust in the work area, which decreases the risk of long-term respiratory damage.

DIRECTION. To avoid the workpiece being thrown from the machine. Never sand tapered or pointed stock with the point facing the feed direction.

POWER DISCONNECT. Disconnect the machine from the power source before changing the sanding sleeve to avoid injuries in the event of an accidental startup.

TABLE INSERTS. Always use the table insert that fits closest to the diameter of the installed sanding drum. A pinch hazard exists from the gap between the table and the oscillating drum. Keeping this gap as small as possible reduces the risk of this hazard.

HAND PLACEMENT. Do not touch or place hands too close to sanding surfaces during operation.



SECTION 2: POWER SUPPLY

Availability

Before installing the machine, consider the availability and proximity of the required power supply circuit. If an existing circuit does not meet the requirements for this machine, a new circuit must be installed. To minimize the risk of electrocution, fire, or equipment damage, installation work and electrical wiring must be done by an electrician or qualified service personnel in accordance with all applicable codes and standards.

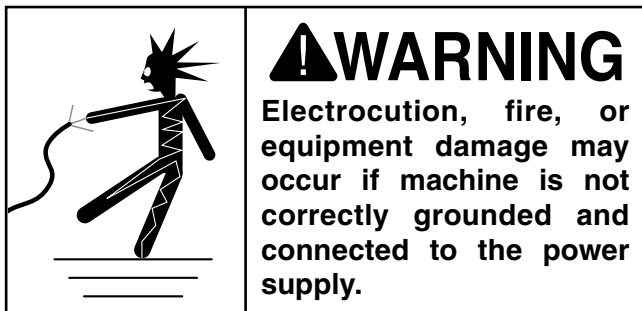

Full-Load Current Rating

The full-load current rating is the amperage a machine draws at 100% of the rated output power. On machines with multiple motors, this is the amperage drawn by the largest motor or sum of all motors and electrical devices that might operate at one time during normal operations.

T26417 Full-Load Current Rating..... 3.4 Amps
T26418 Full-Load Current Rating..... 6.9 Amps

The full-load current is not the maximum amount of amps that the machine will draw. If the machine is overloaded, it will draw additional amps beyond the full-load rating.

If the machine is overloaded for a sufficient length of time, damage, overheating, or fire may result—especially if connected to an undersized circuit. To reduce the risk of these hazards, avoid overloading the machine during operation and make sure it is connected to a power supply circuit that meets the specified circuit requirements.

⚠ WARNING

Serious injury could occur if you connect the machine to power before completing the setup process. DO NOT connect to power until instructed later in this manual.

110V Circuit Requirements

This machine is prewired to operate on a power supply circuit that has a verified ground and meets the following requirements:

Nominal Voltage 110V, 115V, 120V
Cycle.....60 Hz
Phase..... Single-Phase
Power Supply Circuit 15 Amps

A power supply circuit includes all electrical equipment between the breaker box or fuse panel in the building and the machine. The power supply circuit used for this machine must be sized to safely handle the full-load current drawn from the machine for an extended period of time. (If this machine is connected to a circuit protected by fuses, use a time delay fuse marked D.)

⚠ CAUTION

For your own safety and protection of property, consult an electrician if you are unsure about wiring practices or electrical codes in your area.

Note: *The circuit requirements listed in this manual apply to a dedicated circuit—where only one machine will be running at a time. If this machine will be connected to a shared circuit where multiple machines will be running at the same time, consult a qualified electrician to ensure that the circuit is properly sized for safe operation.*



Grounding & Plug Requirements

This machine **MUST** be grounded. In the event of certain malfunctions or breakdowns, grounding reduces the risk of electric shock by providing a path of least resistance for electric current.

This machine is equipped with a power cord that has an equipment-grounding wire and a grounding plug (similar to the figure below). The plug must only be inserted into a matching receptacle (outlet) that is properly installed and grounded in accordance with all local codes and ordinances.

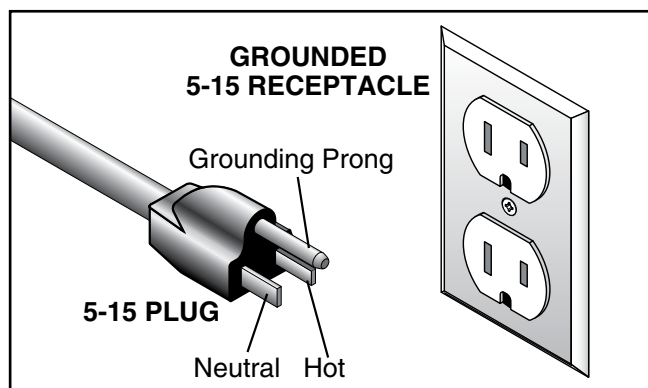
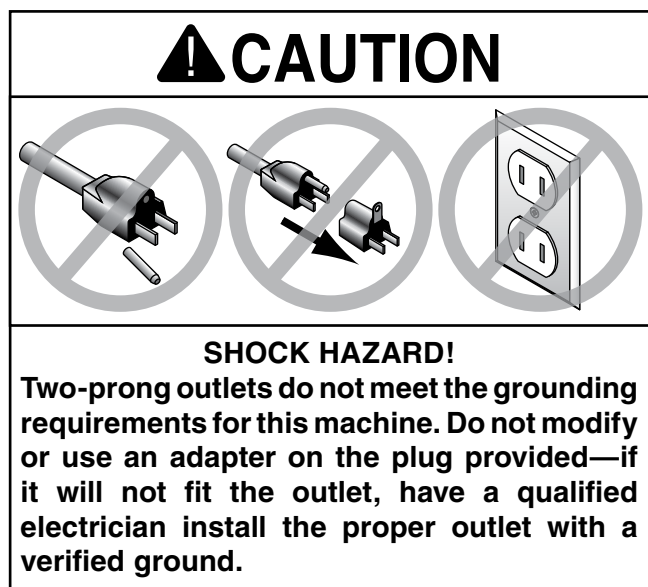

Figure 2. Typical 5-15 plug and receptacle.



Improper connection of the equipment-grounding wire can result in a risk of electric shock. The wire with green insulation (with or without yellow stripes) is the equipment-grounding wire. If repair or replacement of the power cord or plug is necessary, do not connect the equipment-grounding wire to a live (current carrying) terminal.

Check with a qualified electrician or service personnel if you do not understand these grounding requirements, or if you are in doubt about whether the tool is properly grounded. If you ever notice that a cord or plug is damaged or worn, disconnect it from power, and immediately replace it with a new one.

Extension Cords

We do not recommend using an extension cord with this machine. If you must use an extension cord, only use it if absolutely necessary and only on a temporary basis.

Extension cords cause voltage drop, which may damage electrical components and shorten motor life. Voltage drop increases as the extension cord size gets longer and the gauge size gets smaller (higher gauge numbers indicate smaller sizes).

Any extension cord used with this machine must contain a ground wire, match the required plug and receptacle, and meet the following requirements:

- T26417 Minimum Gauge Size16 AWG**
- T26418 Minimum Gauge Size14 AWG**
- Maximum Length (Shorter is Better).....50 ft.**



SECTION 3: SETUP

Unpacking

Your machine was carefully packaged for safe transportation. Remove the packaging materials from around your machine and inspect it. If you discover any damage, *please call us immediately at (570) 546-9663 for advice.*

Save the containers and all packing materials for possible inspection by the carrier or its agent. *Otherwise, filing a freight claim can be difficult.*

When you are completely satisfied with the condition of your shipment, inventory the contents.

Needed for Setup

The following are needed to complete the setup process, but are not included with your machine.

Description	Qty
• Additional People	1
• Safety Glasses	1
• Cleaner/Degreaser	As Needed
• Disposable Shop Rags.....	As Needed
• Dust Collection System	1
• Dust Hose 2"	1
• Hose Clamps 2"	2

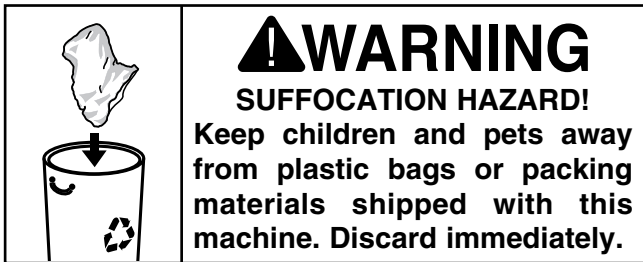

Inventory

The following is a list of items shipped with your machine. Before beginning setup, lay these items out and inventory them.

If any non-proprietary parts are missing (e.g. a nut or a washer), we will gladly replace them; or for the sake of expediency, replacements can be obtained at your local hardware store.

NOTICE

If you cannot find an item on this list, carefully check around/inside the machine and packaging materials. Often, these items get lost in packaging materials while unpacking or they are pre-installed at the factory.

T26417 Inventory (Figure 3)	Qty
A. Oscillating Sander	1
B. Wrench Open-Ends 14-17mm	2
C. Sanding Drums w/ Sanding Sleeves	
- $\frac{3}{4}$ " x $3\frac{1}{2}$ "	1
-1" x $4\frac{1}{2}$ "	1
-2" x $5\frac{1}{2}$ "	1
D. Table Inserts	
- $1\frac{1}{4}$ " x $1\frac{1}{4}$ "	1
- $2\frac{1}{4}$ " x $2\frac{1}{4}$ "	1
- $1\frac{1}{4}$ " x $2\frac{1}{8}$ "	1
- $2\frac{1}{4}$ " x $3\frac{5}{8}$ "	1



Figure 3. T26417 Inventory.

T26418 Inventory Box 2 (Figure 4)	Qty
A. Oscillating Sander	1
B. Wrench Open-Ends 19-22mm	2
C. Sanding Drums w/ Sanding Sleeves	
- $\frac{3}{4}$ " x $4\frac{1}{2}$ "	1
-2" x 9"	1
-3" x 9"	1
D. Table Inserts	
- $1\frac{1}{4}$ " x $1\frac{1}{4}$ "	1
- $2\frac{3}{8}$ " x $2\frac{3}{8}$ "	1
- $3\frac{1}{2}$ " x $3\frac{1}{2}$ "	1
- $1\frac{1}{4}$ " x $2\frac{1}{8}$ "	1
- $2\frac{3}{8}$ " x $3\frac{5}{8}$ "	1
- $3\frac{1}{2}$ " x $4\frac{7}{16}$ "	1
E. Stand (Already Assembled in Picture)	1



Figure 4. T26418 Inventory.



Cleanup

The unpainted surfaces of your machine are coated with a heavy-duty rust preventative that prevents corrosion during shipment and storage. This rust preventative works extremely well, but it will take a little time to clean.

Be patient and do a thorough job cleaning your machine. The time you spend doing this now will give you a better appreciation for the proper care of your machine's unpainted surfaces.

There are many ways to remove this rust preventative, but the following steps work well in a wide variety of situations. Always follow the manufacturer's instructions with any cleaning product you use and make sure you work in a well-ventilated area to minimize exposure to toxic fumes.

Before cleaning, gather the following:

- Disposable Rags
- Cleaner/degreaser (WD-40 works well)
- Safety glasses & disposable gloves
- Plastic paint scraper (optional)

Basic steps for removing rust preventative:

1. Put on safety glasses.
2. Coat the rust preventative with a liberal amount of cleaner/degreaser, then let it soak for 5–10 minutes.
3. Wipe off the surfaces. If your cleaner/degreaser is effective, the rust preventative will wipe off easily. If you have a plastic paint scraper, scrape off as much as you can first, then wipe off the rest with the rag.
4. Repeat **Steps 2–3** as necessary until clean, then coat all unpainted surfaces with a quality metal protectant to prevent rust.

NOTICE

Avoid chlorine-based solvents, such as acetone or brake parts cleaner, that may damage painted surfaces.

Site Considerations

Workbench Load

Refer to the **Machine Data Sheet** for the weight and footprint specifications of your machine. Some workbenches may require additional reinforcement to support the weight of the machine and workpiece materials.

Placement Location

Consider anticipated workpiece sizes and additional space needed for auxiliary stands, work tables, or other machinery when establishing a location for this machine in the shop. Below is the minimum amount of space needed for the machine.

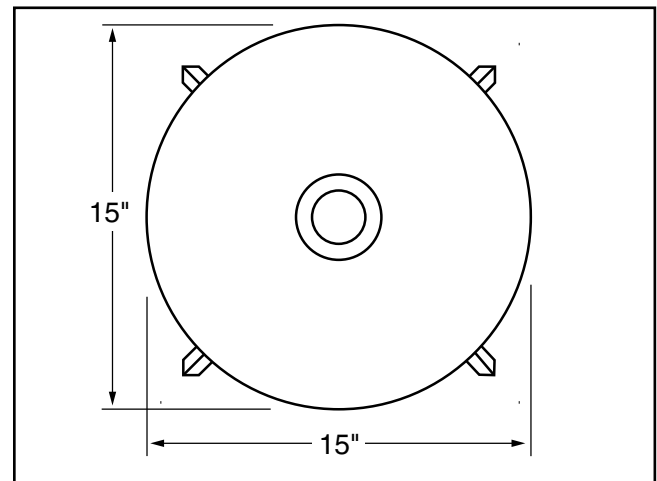

Figure 5. T26417 Minimum working clearances.

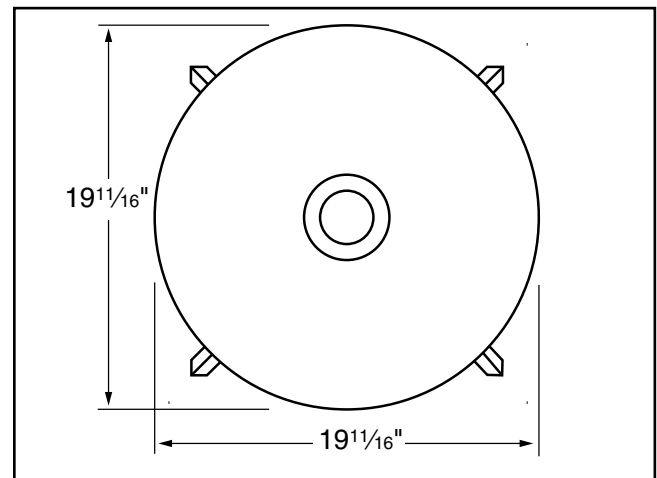

Figure 6. T26418 Minimum working clearances.



Mounting T26417 to Bench

The base of this machine has mounting holes that allow it to be fastened to a workbench or other mounting surface to prevent it from moving during operation and causing accidental injury or damage.

The strongest mounting option is a "Through Mount" (see example below) where holes are drilled all the way through the workbench—and hex bolts, washers, and hex nuts are used to secure the machine in place.

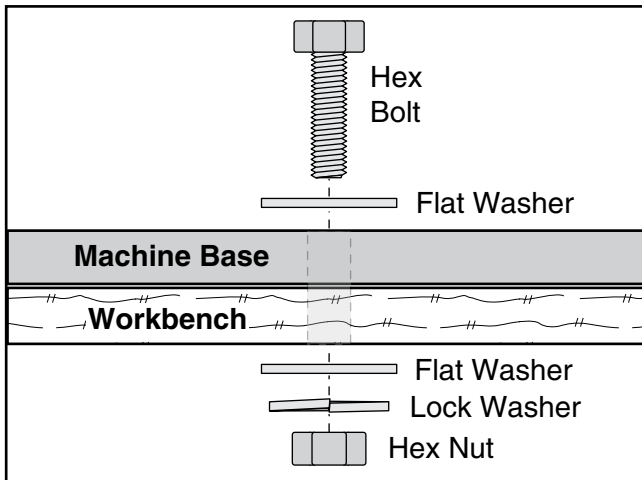

Figure 7. Example of a "Through Mount" setup.

Another option is a "Direct Mount" (see example below) where the machine is secured directly to the workbench with lag screws and washers.

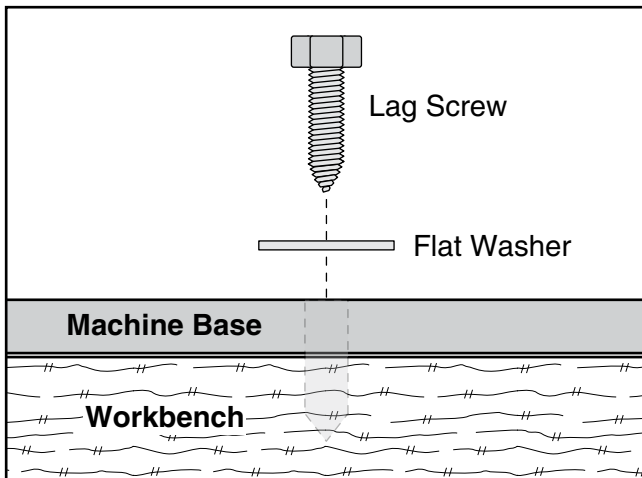

Figure 8. Example of a "Direct Mount" setup.

Anchoring T26418 to Floor

Anchoring machinery to the floor prevents tipping or shifting and reduces vibration that may occur during operation, resulting in a machine that runs slightly quieter and feels more solid.

If the machine will be installed in a commercial or workplace setting, or if it is permanently connected (hardwired) to the power supply, local codes may require that it be anchored to the floor.

If not required by any local codes, fastening the machine to the floor is an optional step. If you choose not to do this with your machine, we recommend placing it on machine mounts, as these provide an easy method for leveling and they have vibration-absorbing pads.

Anchoring to Concrete Floors

Lag shield anchors with lag screws (see below) are a popular way to anchor machinery to a concrete floor, because the anchors sit flush with the floor surface, making it easy to unbolt and move the machine later, if needed. However, anytime local codes apply, you **MUST** follow the anchoring methodology specified by the code.

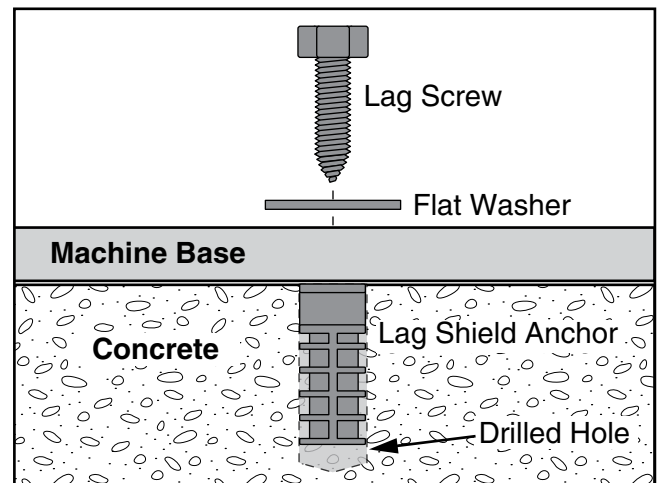

Figure 9. Popular method for anchoring machinery to a concrete floor.



Assembly

Place the spindle assemblies and table inserts in the appropriate-sized accessory slots beneath the table (see **Figure 10**). A sanding drum assembly does not need to be installed until after the test run.

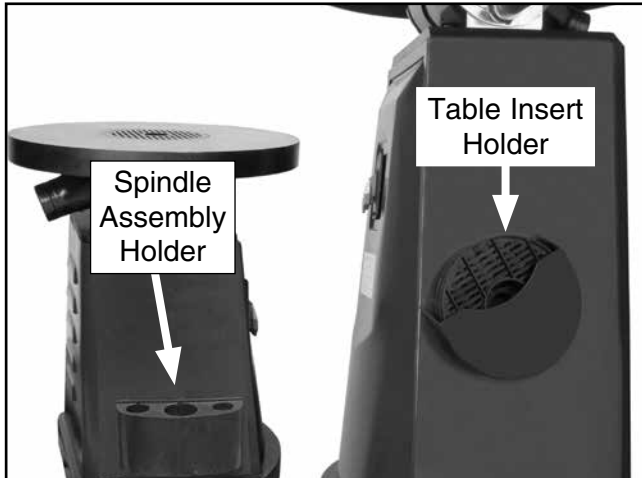

Figure 10. Table insert and spindle assembly holder.

Dust Collection

⚠ CAUTION

This machine creates substantial amounts of dust during operation. Breathing airborne dust on a regular basis can result in permanent respiratory illness. Reduce your risk by wearing a respirator and capturing the dust with a dust collection system.

Recommended CFM at Dust Port: 200 CFM
Do not confuse this CFM recommendation with the rating of the dust collector. To determine the CFM at the dust port, you must consider these variables: (1) CFM rating of the dust collector, (2) hose type and length between the dust collector and the machine, (3) number of branches or wyes, and (4) amount of other open lines throughout the system. Explaining how to calculate these variables is beyond the scope of this manual. Consult an expert or purchase a good dust collection "how-to" book.

To connect a dust collection hose:

1. Fit a 2" dust hose over dust port shown in **Figure 11**, and secure in place with a hose clamp.
2. Tug hose to make sure it does not come off.
Note: A tight fit is necessary for proper performance.

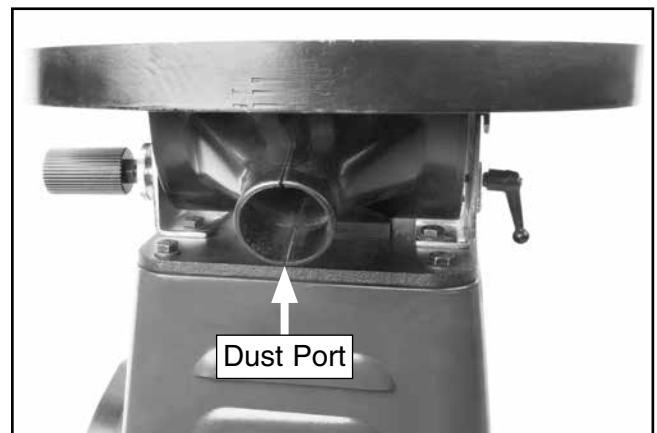

Figure 11. Dust port.



Test Run

Once assembly is complete, test run the machine to ensure it is properly connected to power and safety components function properly.

If you find an unusual problem during the test run, immediately stop the machine, disconnect it from power, and fix the problem **BEFORE** operating the machine again. The **Troubleshooting** table in the **SERVICE** section of this manual can help.

⚠️ WARNING

Serious injury or death can result from using this machine **BEFORE** understanding its controls and related safety information. **DO NOT** operate, or allow others to operate, machine until the information is understood.

⚠️ WARNING

DO NOT start machine until all preceding setup instructions have been performed. Operating an improperly setup machine may result in malfunction or unexpected results that can lead to serious injury, death, or machine/property damage.

To test run machine:

1. Clear all setup tools away from machine.
2. Connect machine to power supply.
3. Turn machine **ON**. Verify motor operation, and then turn machine **OFF**.

The motor should run smoothly and without unusual problems or noises.

4. Remove switch disabling key, as shown in **Figure 12**.

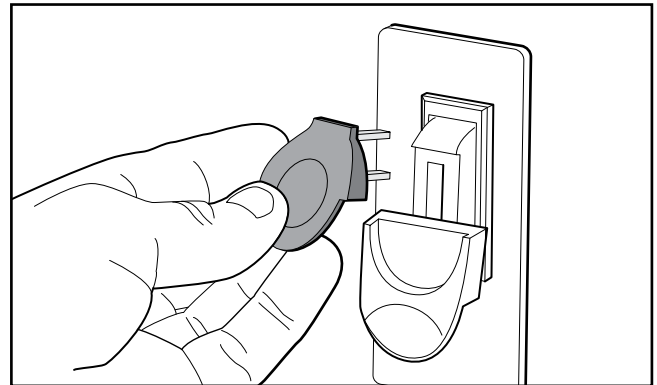

Figure 12. Removing switch key from paddle switch.

5. Try to start machine by pressing switch button.

Machine should **NOT** start. If it does start, the switch disabling feature is not functioning properly and the switch must be replaced.



SECTION 4: OPERATIONS

Operation Overview

The purpose of this overview is to provide the novice machine operator with a basic understanding of how the machine is used during operation, so the machine controls/components discussed later in this manual are easier to understand.

Due to the generic nature of this overview, it is **not** intended to be an instructional guide. To learn more about specific operations, read this entire manual and seek additional training from experienced machine operators, and do additional research outside of this manual by reading "how-to" books, trade magazines, or websites.

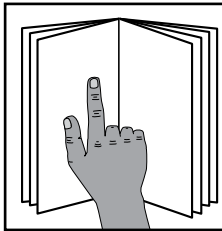

!WARNING

To reduce your risk of serious injury, read this entire manual **BEFORE** using machine.

!WARNING

To reduce risk of eye injury from flying chips or lung damage from breathing dust, **always wear safety glasses and a respirator when operating this machine.**

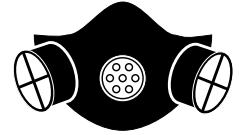

NOTICE

If you are not experienced with this type of machine, **WE STRONGLY RECOMMEND** that you seek additional training outside of this manual. Read books/magazines or get formal training before beginning any projects. Regardless of the content in this section, Grizzly Industrial will not be held liable for accidents caused by lack of training.



To complete a typical operation, the operator does the following:

1. Examines workpiece to make sure it is suitable for sanding.
2. If necessary, tilts table to correct angle and locks it in place.
3. Install sanding drum assembly. (Refer to **Installing Sanding Drum/Sleeve** sub-section on this page.)
4. Selects table insert best suited to accommodate size of the sanding drum and tilt of the table.
5. Puts on safety glasses and a respirator.
6. Starts oscillating sander.
7. Feeds workpiece against direction of spindle rotation, maintaining a safe working distance between hands and sanding drum.
8. Turns machine **OFF**.

Installing Sanding Drum/Sleeve

Installing Sanding Drums

1. DISCONNECT MACHINE FROM POWER.
2. Thread the assembled sanding spindle, drum, and sleeve into the machine spindle.
3. Insert 22mm and 17mm wrenches through access panel beneath table (see **Figure 13**) and onto machine spindle and sanding spindle hex nuts. Tighten sanding spindle by turning counterclockwise when looking down on the spindle.

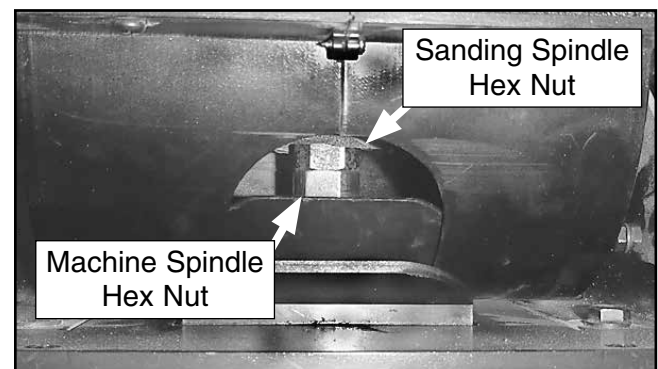

Figure 13. Spindle hex nut.

4. To remove assembly, reverse **Steps 2–3**.



Changing Spindle Sanding Sleeve

1. DISCONNECT MACHINE FROM POWER!
2. Secure sanding spindle in the machine spindle or with a vice.
3. Remove sanding spindle hex nut and top washer (see **Figure 14**).

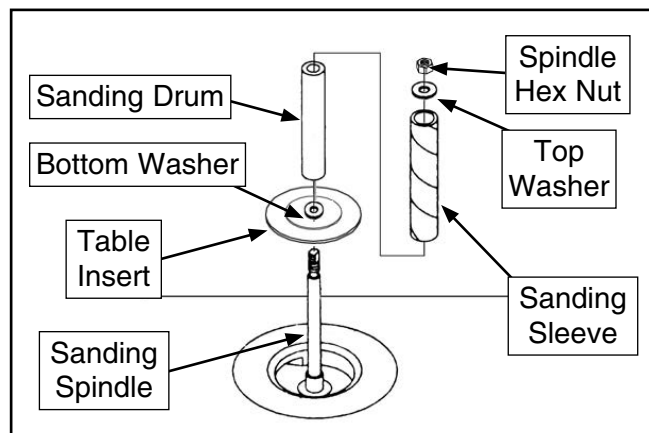

Figure 14. Assembly order.

4. Pull sanding drum and sleeve off of sanding spindle.
5. Pull sanding sleeve off of sanding drum.
6. Re-assemble new sanding sleeve and sanding drum.

Note: Sanding sleeve slides over sanding drum easier if done prior to placing drum over spindle.

7. Re-install sanding spindle assembly as illustrated in **Figure 14**.
8. Screw sanding spindle assembly into machine spindle.
9. Tighten spindle hex nut until sanding drum places slight pressure on sanding sleeve.



Tilting Table

To tilt the table:

1. Loosen locking lever shown in **Figure 15** by rotating counterclockwise.

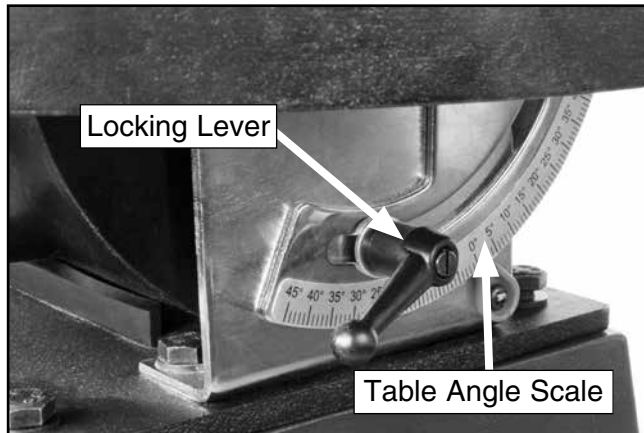

Figure 15. Loosening table tilt lock lever.

2. Loosen locking ring that holds table tilt by rotating it counterclockwise (see **Figure 16**).

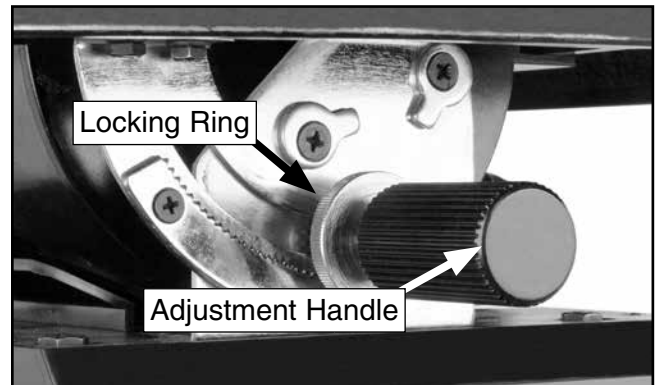

Figure 16. Loosening locking ring.

3. Set table tilt using angle scale while rotating adjustment handle.
4. Tighten locking lever and locking ring.



Table Inserts

To ensure the workpiece is supported during sanding operations, use the table insert that matches the corresponding drum and sleeve (see table below). It is important to keep the gap between the table insert and drum as small as possible to reduce the risk of a pinch hazard. Use the oval inserts when sanding with the table tilted.

T26417

Sanding Sleeves	Sanding Drums	Table Inserts
3/4"	3/4"	1"
1"	1"	1 1/4"
2"	2"	2 1/4"

T26418

Sanding Sleeves	Sanding Drums	Table Inserts
3/4"	3/4"	1"
2"	2"	2 1/4"
3"	3"	3 1/4"

Sanding

To sand a workpiece:

1. Turn spindle sander **ON** and allow spindle to reach full speed.
2. Using both hands to maintain control of workpiece, guide workpiece against rotation of spindle, as shown in **Figure 17**. DO NOT force workpiece against sanding sleeve. Allow machine to do the work.

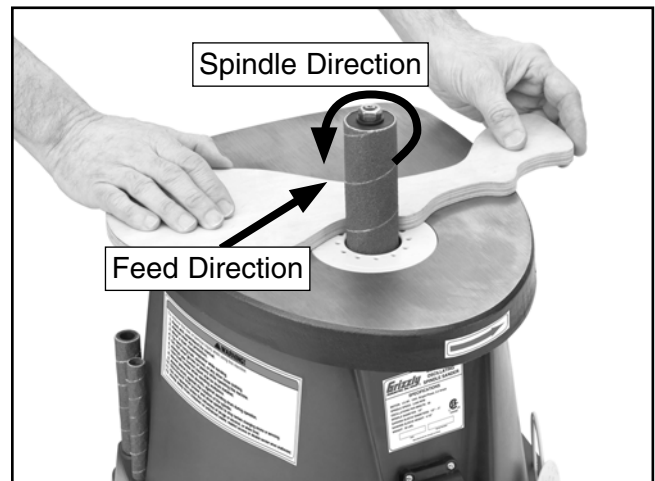

Figure 17. Sanding workpiece example.



SECTION 5: ACCESSORIES

!WARNING

Installing unapproved accessories may cause machine to malfunction, resulting in serious personal injury or machine damage. To reduce this risk, only install accessories recommended for this machine by Grizzly.

NOTICE

Refer to our website or latest catalog for additional recommended accessories.

PRO-STIK® Belt Cleaners

W1304—1³/₈" x 4¹/₄"

W1305—1³/₈" x 8¹/₂"

W1306—Small (2" x 2" x 12")

W1307—Large (1¹/₂" x 1¹/₂" x 8¹/₂")

These crepe-rubber belt cleaners quickly remove gum and grit from belts, sleeves, and discs without damage. Extend the life of your belts, sleeves, or discs with this innovative natural cleaner.



Figure 18. Sanding Sleeve cleaners.

- T20501—Face Shield Crown Protector 4"
- T20502—Face Shield Crown Protector 7"
- T20503—Face Shield Window
- T20452—"Kirova" Anti-Reflective S. Glasses
- T20451—"Kirova" Clear Safety Glasses
- H7194—Bifocal Safety Glasses 1.5
- H7195—Bifocal Safety Glasses 2.0
- H7196—Bifocal Safety Glasses 2.5



Figure 19. Eye protection.

Machine Lubricants

G5562—SLIPIT® 1 Qt. Gel

G5563—SLIPIT® 12 oz Spray

G2871—Boeshield® T-9 12 oz Spray

G2870—Boeshield® T-9 4 oz Spray

H3788—G96® Gun Treatment 12 oz Spray

H3789—G96® Gun Treatment 4.5 oz Spray



Figure 20. Recommended products for protecting unpainted cast iron/steel parts on machinery.

order online at www.grizzly.com or call 1-800-523-4777



Grizzly offers a wide variety of rigid aluminum oxide sanding sleeves that are perfect for use with popular sanding drum kits.



Figure 21. 3-pack of hard sanding sleeves.

MODEL	SIZE	GRIT
H5435	¾" x 4½"	60
H5436	¾" x 4½"	80
H5437	¾" x 4½"	100
H5438	¾" x 4½"	120
H5439	¾" x 4½"	150
H5440	1" x 4½"	60
H5441	1" x 4½"	80
H5442	1" x 4½"	100
H5443	1" x 4½"	120
H5444	1" x 4½"	150
H6674	2" x 5½"	60
H6675	2" x 5½"	80
H6676	2" x 5½"	100
H6677	2" x 5½"	120
H6678	2" x 5½"	150
D1490	2" x 9"	60
D1491	2" x 9"	80
D1492	2" x 9"	100
D1493	2" x 9"	120
D1494	2" x 9"	150

H3632—Respirator Facepiece

H3635—Particulate Aerosol Cartridges, 2 pk.

This lightweight elastomeric facepiece has cradle suspension, easy adjust headstraps and low profile for greater field of vision and compatibility with normal use of glasses or goggles. Purchase cartridges separately depending upon intended application.



Figure 22. Medium sized respirator.

G1163—1HP Floor Model Dust Collector

G0710—1HP Wall-Mount Dust Collector

G3591—30 Micron Replacement Bag

H4340—3.0 Micron Upgrade Bag

Excellent point-of-use dust collectors that can be used next to the machine with only a small amount of ducting. Specifications: 450 CFM, 7.2" static pressure, 2 cubic foot bag, and 30 micron filter. Motor is 1HP, 110V/220V, 14A/7A.



Figure 23. Point-of-use dust collectors.



SECTION 6: MAINTENANCE

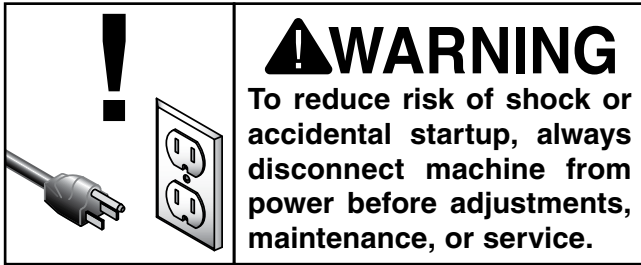

Schedule

For optimum performance from your machine, follow this maintenance schedule and refer to any specific instructions given in this section.

Daily Check:

- Loose mounting bolts.
- Sanding drums and sleeves for wear or damage.
- Worn or damaged wires.
- Any other unsafe condition.

Cleaning

Cleaning Model T26417/T26418 is relatively easy. Vacuum excess wood chips and sawdust, and wipe off the remaining dust with a dry cloth. If any resin has built up, use a resin dissolving cleaner to remove it. Treat all unpainted cast iron and steel with a non-staining lubricant after cleaning, such as G96® Gun Treatment, SLIPIT®, or Boeshield® T-9.

Lubrication

The bearings in the motor are shielded, permanently lubricated and require no maintenance.

Every month, the table tilt assembly should be cleaned and greased to prevent corrosion and keep the table moving freely.

To lubricate table tilt assembly:

1. DISCONNECT SANDER FROM POWER!
2. Thoroughly clean lubrication areas of any grease and dust.
3. Apply a fresh light layer of multipurpose grease to areas indicated in **Figure 24–25** and to corresponding areas on other side of table tilt assembly. Tilt table several times to disperse grease.

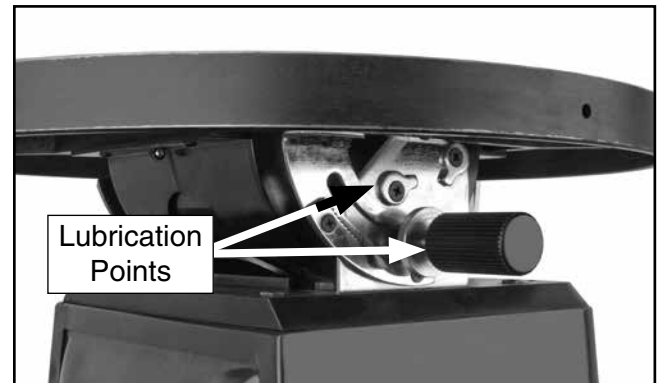

Figure 24. Lubrication points.

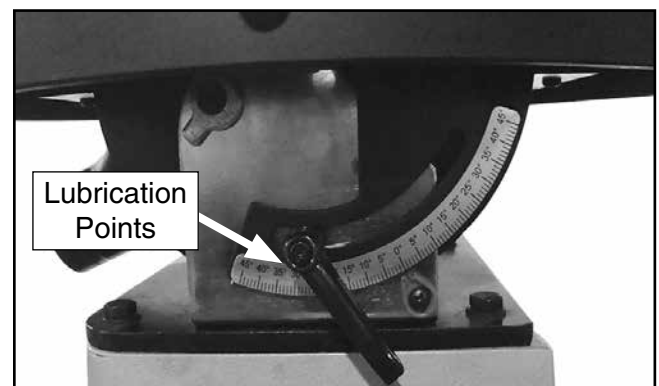

Figure 25. Scale side lubrication points.



SECTION 7: SERVICE

Review the troubleshooting and procedures in this section if a problem develops with your machine. If you need replacement parts or additional help with a procedure, call our Technical Support at (570) 546-9663.

Note: Please gather the serial number and manufacture date of your machine before calling.

Troubleshooting

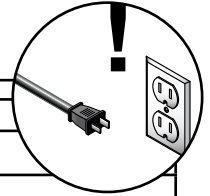

Symptom	Possible Cause	Possible Solution
Motor will not start; fuses or circuit breakers blow.	<ol style="list-style-type: none"> 1. Switch disabling key removed. 2. Loose connections at motor or switch. 3. Switch, bridge rectifier or motor at fault. 	<ol style="list-style-type: none"> 1. Insert key to enable switch. 2. Inspect all motor connections for loose or open connections. 3. Replace the component at fault.
Motor stalls (resulting in blown fuses or tripped circuit).	<ol style="list-style-type: none"> 1. Motor overloaded. 	<ol style="list-style-type: none"> 1. Reduce feeding pressure.
Deep sanding grooves or scars in workpiece.	<ol style="list-style-type: none"> 1. Sanding sleeve too coarse for the desired finish. 2. Workpiece sanded across the grain. 3. Too much feeding pressure against workpiece. 	<ol style="list-style-type: none"> 1. Use a finer grit sanding sleeve. 2. Sand with the grain. 3. Reduce pressure on workpiece while sanding.
Grains rub off the sanding sleeve.	<ol style="list-style-type: none"> 1. Sanding sleeve has been stored in an incorrect environment. 2. Sanding sleeve has been folded or smashed. 	<ol style="list-style-type: none"> 1. Store sanding sleeve away from extremely dry or hot temperatures. 2. Store sanding sleeves separately and not folded or flat.
Sanding surfaces clog quickly or burn.	<ol style="list-style-type: none"> 1. Too much pressure against sleeve. 2. Sanding softwood or wood with a high sap content. 	<ol style="list-style-type: none"> 1. Reduce pressure on workpiece while sanding. 2. Either use different wood or plan on cleaning/ replacing sleeves frequently.
Burn marks on workpiece.	<ol style="list-style-type: none"> 1. Using too fine of sanding grit. 2. Using too much pressure. 3. Work held still for too long. 	<ol style="list-style-type: none"> 1. Use a coarser grit sanding sleeve. 2. Reduce pressure on workpiece while sanding. 3. Do not keep workpiece in one place for too long.



SECTION 8: WIRING

These pages are current at the time of printing. However, in the spirit of improvement, we may make changes to the electrical systems of future machines. Compare the manufacture date of your machine to the one stated in this manual, and study this section carefully.

If there are differences between your machine and what is shown in this section, call Technical Support at (570) 546-9663 for assistance BEFORE making any changes to the wiring on your machine. An updated wiring diagram may be available. **Note:** *Please gather the serial number and manufacture date of your machine before calling. This information can be found on the main machine label.*

⚠ WARNING

Wiring Safety Instructions

SHOCK HAZARD. Working on wiring that is connected to a power source is extremely dangerous. Touching electrified parts will result in personal injury including but not limited to severe burns, electrocution, or death. Disconnect the power from the machine before servicing electrical components!

MODIFICATIONS. Modifying the wiring beyond what is shown in the diagram may lead to unpredictable results, including serious injury or fire. This includes the installation of unapproved after-market parts.

WIRE CONNECTIONS. All connections must be tight to prevent wires from loosening during machine operation. Double-check all wires disconnected or connected during any wiring task to ensure tight connections.

CIRCUIT REQUIREMENTS. You MUST follow the requirements at the beginning of this manual when connecting your machine to a power source.

WIRE/COMPONENT DAMAGE. Damaged wires or components increase the risk of serious personal injury, fire, or machine damage. If you notice that any wires or components are damaged while performing a wiring task, replace those wires or components.

MOTOR WIRING. The motor wiring shown in these diagrams is current at the time of printing but may not match your machine. If you find this to be the case, use the wiring diagram inside the motor junction box.













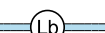

CAPACITORS/INVERTERS. Some capacitors and power inverters store an electrical charge for up to 10 minutes after being disconnected from the power source. To reduce the risk of being shocked, wait at least this long before working on capacitors.

EXPERIENCING DIFFICULTIES. If you are experiencing difficulties understanding the information included in this section, contact our Technical Support at (570) 546-9663.

NOTICE

The photos and diagrams included in this section are best viewed in color. You can view these pages in color at www.grizzly.com.

COLOR KEY

BLACK		BLUE		YELLOW		LIGHT BLUE	
WHITE		BROWN		YELLOW GREEN		BLUE WHITE	
GREEN		GRAY		PURPLE		TURQUOISE	
RED		ORANGE		PINK			



T26417 Wiring Diagram

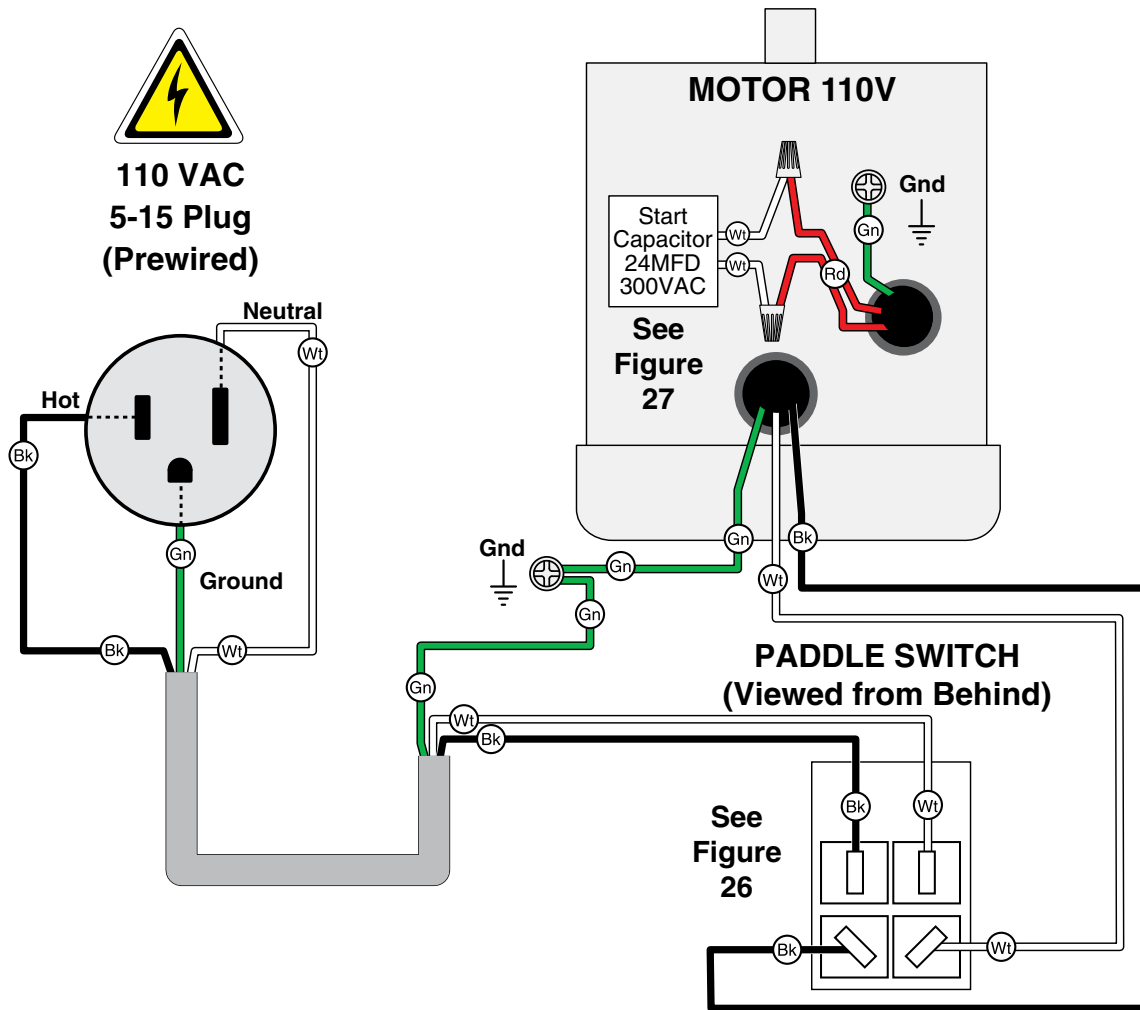

Figure 26. T26417 switch connections.

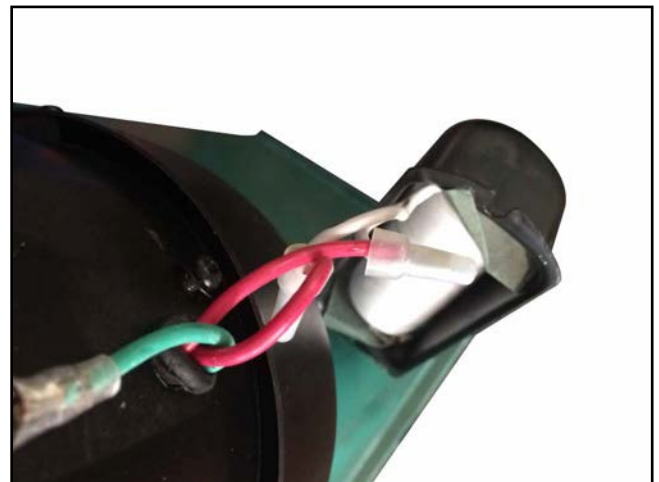

Figure 27. T26417 capacitor connections.



T26418 Wiring Diagram

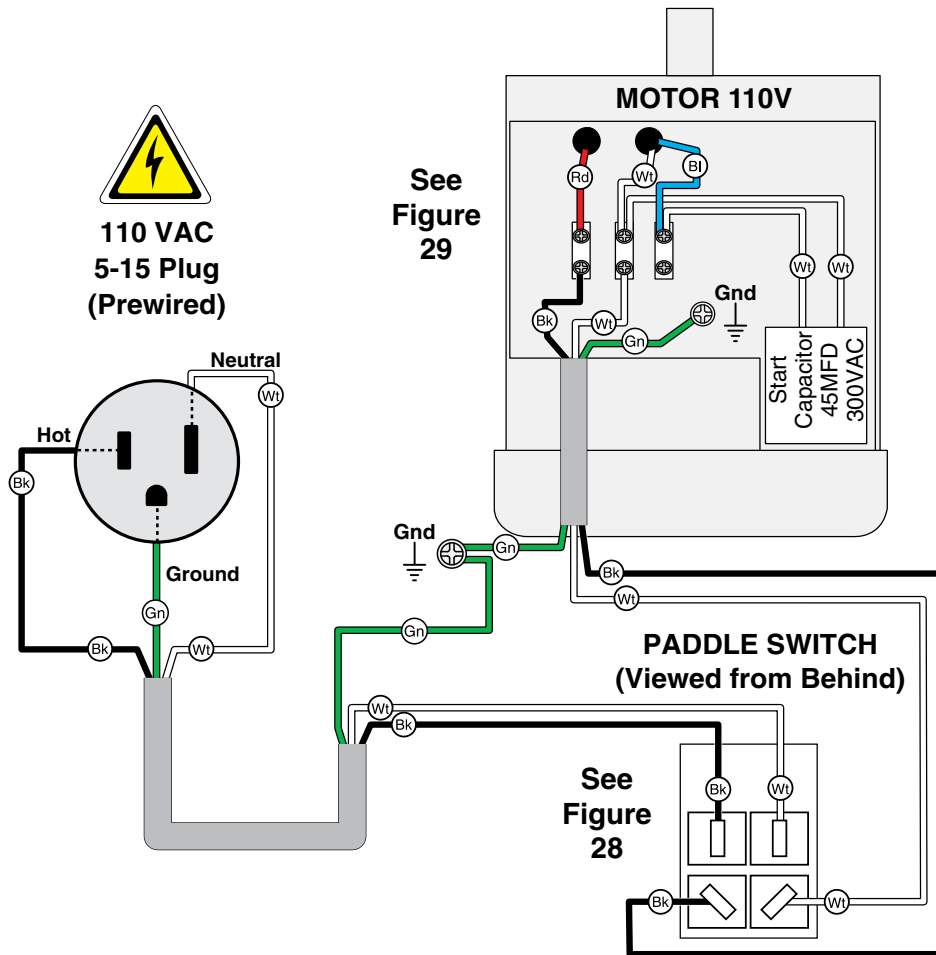

Figure 28. T26418 switch connection.

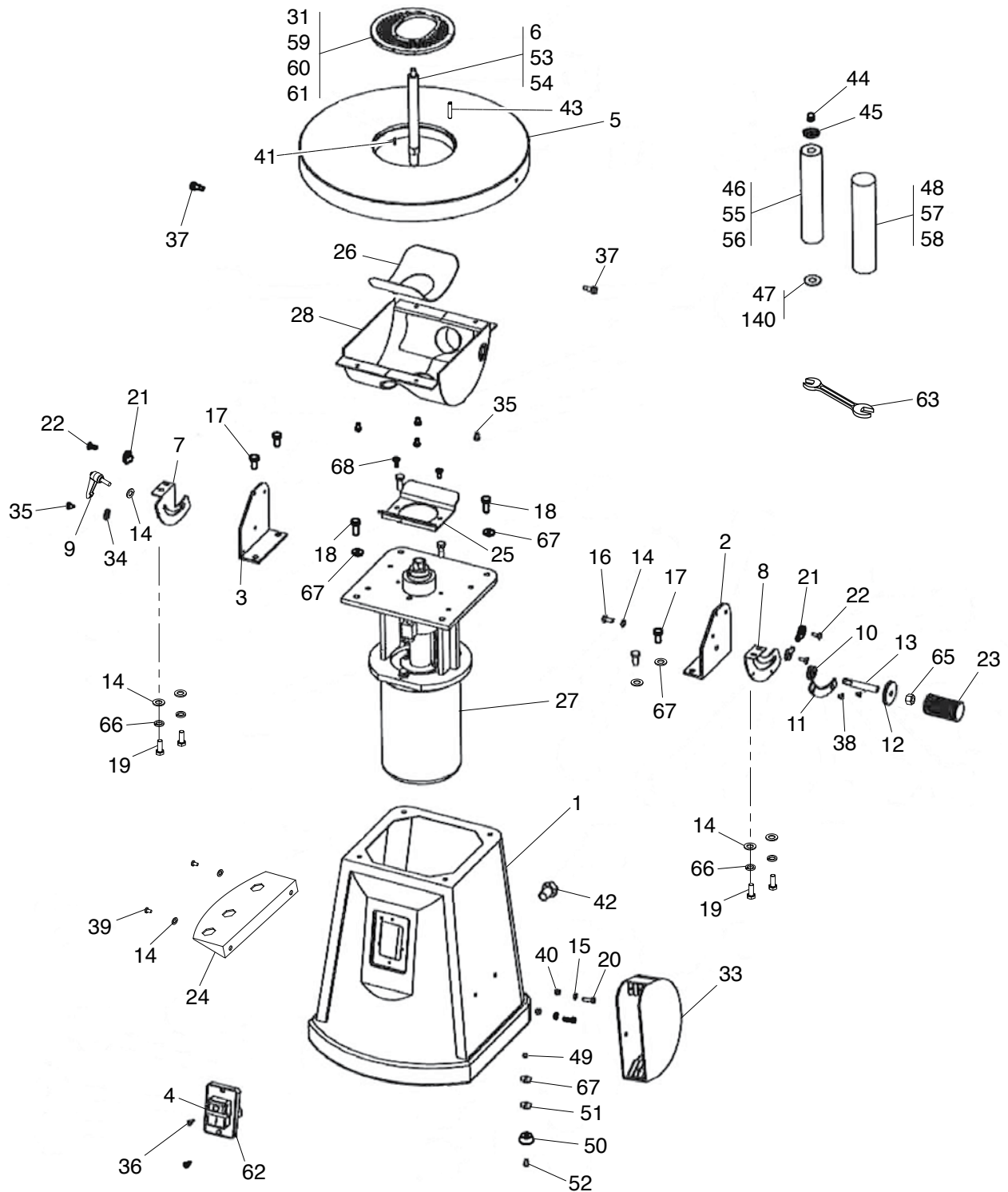

Figure 29. T26418 motor connections.



SECTION 9: PARTS

T26417 Main



Please Note: We do our best to stock replacement parts whenever possible, but we cannot guarantee that all parts shown here are available for purchase. Call (800) 523-4777 or visit our online parts store at www.grizzly.com to check for availability.

Model T26417/T26418 (Mfd. Since 11/13)



T26417 Main

REF	PART #	DESCRIPTION
1	PT26417001	STAND
2	PT26417002	TABLE BRACKET (RH)
3	PT26417003	TABLE BRACKET (LH)
4	PT26417004	GRIZZLY SAFETY PADDLE SWITCH
5	PT26417005	WORK TABLE
6	PT26417006	SPINDLE 10MM X 3-1/2"
7	PT26417007	TILT BRACKET (LH)
8	PT26417008	TILT BRACKET (RH)
9	PT26417009	ADJUSTABLE HANDLE M6-1 X 10
10	PT26417010	TILT GEAR 21T
11	PT26417011	TILT RACK
12	PT26417012	LOCKING THUMBWHEEL
13	PT26417013	TILT SHAFT
14	PT26417014	FLAT WASHER 6MM
15	PT26417015	FLAT WASHER 5MM
16	PT26417016	HEX BOLT M6-1 X 12
17	PT26417017	HEX BOLT M8-1.25 X 16
18	PT26417018	HEX BOLT M8-1.25 X 20
19	PT26417019	HEX BOLT M6-1 X 16
20	PT26417020	HEX BOLT M5-.8 X 16
21	PT26417021	ECCENTRIC SPACER
22	PT26417022	FLAT HD SCR M6-1 X 10
23	PT26417023	TILT HANDLE
24	PT26417024	DRUM STORAGE RACK
25	PT26417025	DUST DEFLECTOR (LOWER)
26	PT26417026	DUST DEFLECTOR (UPPER)
27	PT26417027	OSCILLATOR ASSEMBLY
28	PT26417028	DUST COLLECTION CHUTE
31	PT26417031	TABLE INSERT 1-1/4" ID
33	PT26417033	TABLE INSERT STORAGE RACK
34	PT26417034	ANGLE INDICATOR
35	PT26417035	PHLP HD SCR M5-.8 X 8
36	PT26417036	PHLP HD SCR M4-.7 X 12

REF	PART #	DESCRIPTION
37	PT26417037	STEP BOLT M6-1 X 10
38	PT26417038	PHLP HD SCR M5-.8 X 6
39	PT26417039	HEX BOLT M6-1 X 10
40	PT26417040	HEX NUT M5-.8
41	PT26417041	ROLL PIN 2.5 X 20
42	PT26417042	STRAIN RELIEF M18 LT
43	PT26417043	KEY 5 X 5 X 50
44	PT26417044	HEX NUT M8-1.25 LH
45	PT26417045	FLAT WASHER 8MM
46	PT26417046	SANDING DRUM 3/4" X 3-1/2" (RUBBER)
47	PT26417047	FLAT WASHER 3/8
48	PT26417048	SANDING SLEEVE 3/4" X 3-1/2" 100-GRIT
49	PT26417049	HEX NUT M8-1.25
50	PT26417050	FOOT (RUBBER)
51	PT26417051	FLAT WASHER 8MM
52	PT26417052	HEX BOLT M8-1.25 X 25
53	PT26417053	SPINDLE 10MM X 4-1/2"
54	PT26417054	SPINDLE 16MM X 5-1/2"
55	PT26417055	SANDING DRUM 1" X 4-1/2" (RUBBER)
56	PT26417056	SANDING DRUM 2" X 5-1/2" (RUBBER)
57	PT26417057	SANDING SLEEVE 1" X 4-1/2" 100-GRIT
58	PT26417058	SANDING SLEEVE 2" X 5-1/2" 100-GRIT
59	PT26417059	TABLE INSERT 2-3/8" ID
60	PT26417060	TABLE INSERT 1-1/4" X 2-1/8" ID
61	PT26417061	TABLE INSERT 2-3/8" X 3-5/8" ID
62	PT26417062	SWITCH BOX COVER
63	PT26417063	WRENCH 14 X 17MM OPEN-ENDS
65	PT26417065	HEX NUT M10-1.5
66	PT26417066	LOCK WASHER 6MM
67	PT26417067	FLAT WASHER 8MM
68	PT26417068	PHLP HD SCR M6-1 X 12
140	PT26417140	FLAT WASHER 5/8



T26417 Oscillator Assembly

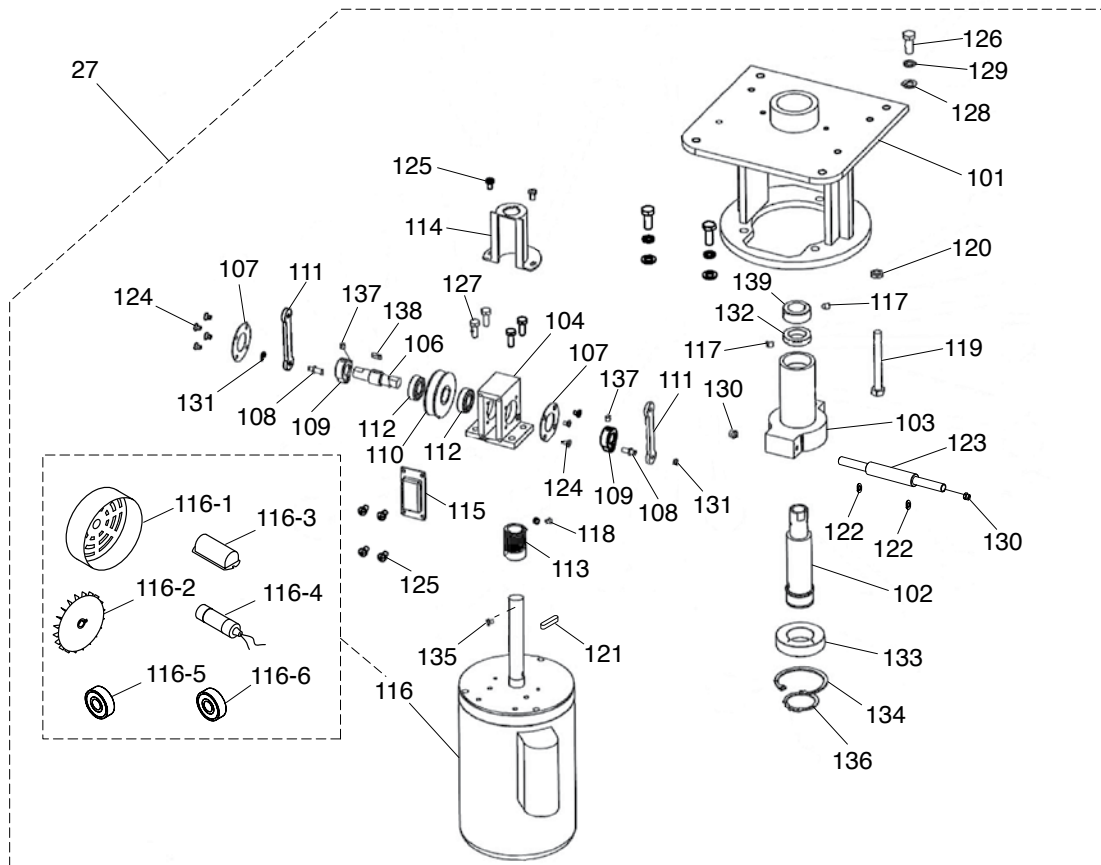

REF	PART #	DESCRIPTION
27	PT26417027	OSCILLATOR ASSEMBLY
101	PT26417101	MOTOR MOUNT
102	PT26417102	SPINDLE BASE
103	PT26417103	QUILL
104	PT26417104	OSCILLATOR BRACKET
106	PT26417106	OSCILLATOR SHAFT
107	PT26417107	END PLATE
108	PT26417108	CRANK SHAFT
109	PT26417109	ECCENTRIC LOCK COLLAR
110	PT26417110	WORM WHEEL
111	PT26417111	SWING ARM
112	PT26417112	BALL BEARING 6001ZZ
113	PT26417113	WORM
114	PT26417114	WORM COVER
115	PT26417115	BRACKET FRONT PLATE
116	PT26417116	MOTOR 1/2HP 110V 1-PH
116-1	PT26417116-1	MOTOR FAN COVER
116-2	PT26417116-2	MOTOR FAN
116-3	PT26417116-3	CAPACITOR COVER
116-4	PT26417116-4	S CAPACITOR 24M 300V 35 X 72MM
116-5	PT26417116-5	BALL BEARING 6203ZZ
116-6	PT26417116-6	BALL BEARING 6202ZZ
117	PT26417117	SET SCREW M6-1 X 6 DOG-PT

REF	PART #	DESCRIPTION
118	PT26417118	SET SCREW M6-1 X 6 DOG-PT
119	PT26417119	HEX BOLT M8-1.25 X 75
120	PT26417120	HEX NUT M8-1.25 THIN
121	PT26417121	KEY 5 X 5 X 50
122	PT26417122	LOCK WASHER 5MM
123	PT26417123	SWING ARM SHAFT
124	PT26417124	FLAT HD SCR M4-.7 X 6
125	PT26417125	PHLP HD SCR M5-.8 X 8
126	PT26417126	HEX BOLT M8-1.25 X 20
127	PT26417127	HEX BOLT M6-1 X 16
128	PT26417128	FLAT WASHER 8MM
129	PT26417129	LOCK WASHER 8MM
130	PT26417130	LOCK NUT M5-.8
131	PT26417131	E-CLIP 5MM
132	PT26417132	BALL BEARING 6904ZZ
133	PT26417133	BALL BEARING 6006ZZ
134	PT26417134	INT RETAINING RING 55MM
135	PT26417135	FLAT HD SCR M4-.7 X 10
136	PT26417136	EXT RETAINING RING 30MM
137	PT26417137	SET SCREW M5-.8 X 6 DOG-PT
138	PT26417138	KEY 4 X 4 X 12
139	PT26417139	QUILL DUST SEAL



T26417 Machine Labels & Cosmetics

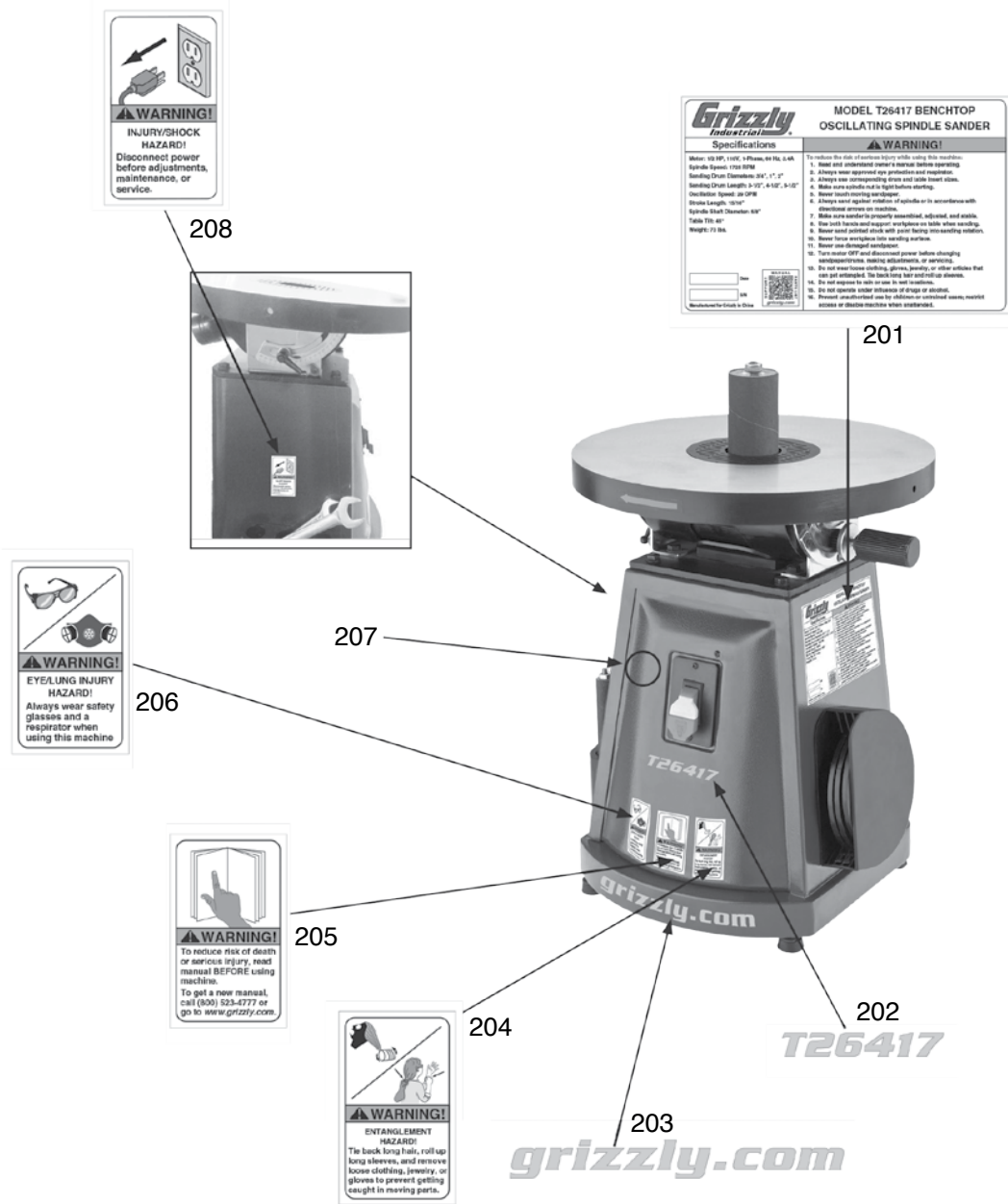

REF	PART #	DESCRIPTION
201	PT26417201	MACHINE ID LABEL
202	PT26417202	MODEL NUMBER LABEL
203	PT26417203	GRIZZLY.COM LABEL
204	PT26417204	ENTANGLEMENT HAZARD LABEL

REF	PART #	DESCRIPTION
205	PT26417205	READ MANUAL LABEL
206	PT26417206	EYE/LUNG HAZARD LABEL
207	PT26417207	GRIZZLY GREEN TOUCH-UP PAINT
208	PT26417208	DISCONNECT WARNING LABEL

⚠️ WARNING

Safety labels help reduce the risk of serious injury caused by machine hazards. If any label comes off or becomes unreadable, the owner of this machine **MUST** replace it in the original location before resuming operations. For replacements, contact (800) 523-4777 or www.grizzly.com.



T26418 Main

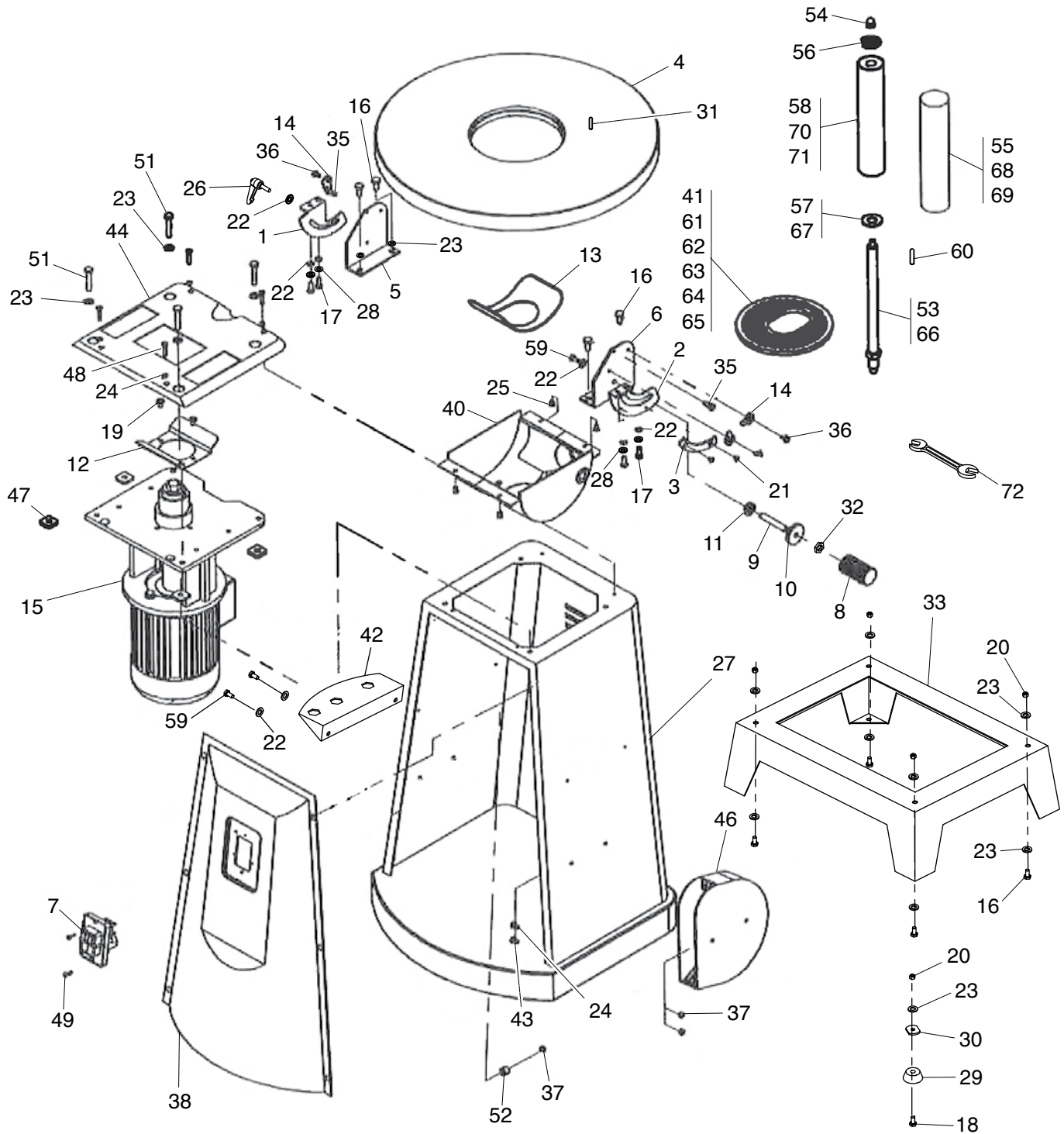

Please Note: We do our best to stock replacement parts whenever possible, but we cannot guarantee that all parts shown here are available for purchase. Call (800) 523-4777 or visit our online parts store at www.grizzly.com to check for availability.



T26418 Main

REF	PART #	DESCRIPTION
1	PT26418001	TILT BRACKET (LH)
2	PT26418002	TILT BRACKET (RH)
3	PT26418003	ANGLE RACK
4	PT26418004	WORK TABLE
5	PT26418005	TABLE BRACKET (LH)
6	PT26418006	TABLE BRACKET (RH)
7	PT26418007	GRIZZLY SAFETY PADDLE SWITCH
8	PT26418008	TILT HANDLE
9	PT26418009	TILT SHAFT
10	PT26418010	LOCKING THUMBWHEEL
11	PT26418011	TILT GEAR 21T
12	PT26418012	DUST DEFLECTOR (LOWER)
13	PT26418013	DUST DEFLECTOR (UPPER)
14	PT26418014	ECCENTRIC SPACER
15	PT26418015	OSCILLATOR ASSEMBLY
16	PT26418016	HEX BOLT M8-1.25 X 16
17	PT26418017	HEX BOLT M6-1 X 16
18	PT26418018	HEX BOLT M8-1.25 X 25
19	PT26418019	PHLP HD SCR M6-1 X 10
20	PT26418020	HEX NUT M8-1.25
21	PT26418021	FLAT HD SCR M5-.8 X 6
22	PT26418022	FLAT WASHER 6MM
23	PT26418023	FLAT WASHER 8MM
24	PT26418024	FLAT WASHER 5MM
25	PT26418025	HEX BOLT M5-.8 X 8
26	PT26418026	ADJUSTABLE HANDLE M6-1 X 10
27	PT26418027	STAND
28	PT26418028	LOCK WASHER 6MM
29	PT26418029	FOOT (RUBBER)
30	PT26418030	HEX NUT M8-1.25
31	PT26418031	ROLL PIN 2.5 X 12
32	PT26418032	HEX NUT M5-.8 THIN
33	PT26418033	BASE
35	PT26418035	STEP BOLT M6-1 X 10

REF	PART #	DESCRIPTION
36	PT26418036	FLAT HD SCR M6-1 X 12
37	PT26418037	HEX NUT M5-.8
38	PT26418038	STAND FRONT PANEL
40	PT26418040	DUST COLLECTION CHUTE
41	PT26418041	TABLE INSERT 1-1/4" ID
42	PT26418042	DRUM STORAGE RACK
43	PT26418043	PHLP HD SCR M5-.8 X 12
44	PT26418044	OSCILLATOR ASSEMBLY MOUNT
46	PT26418046	TABLE INSERT STORAGE RACK
47	PT26418047	SQUARE CUSHION (RUBBER)
48	PT26418048	PHLP HD SCR M5-.8 X 25
49	PT26418049	PHLP HD SCR M6-1 X 14
51	PT26418051	HEX BOLT M8-1.25 X 40
52	PT26418052	CUSHION (RUBBER)
53	PT26418053	SPINDLE 10MM X 4-1/2"
54	PT26418054	HEX NUT M10-1.5 LH
55	PT26418055	SANDING SLEEVE 3/4" X 4-1/2" 100-GRIT
56	PT26418056	FLAT WASHER 8MM
57	PT26418057	FLAT WASHER 3/8
58	PT26418058	SANDING DRUM 3/4" X 4-1/2" (RUBBER)
59	PT26418059	HEX BOLT M6-1 X 12
60	PT26418060	KEY 5 X 5 X 50
61	PT26418061	TABLE INSERT 1-1/4" X 2-1/8" ID
62	PT26418062	TABLE INSERT 2-3/8" ID
63	PT26418063	TABLE INSERT 2-3/8" X 3-5/8" ID
64	PT26418064	TABLE INSERT 3-1/2" ID
65	PT26418065	TABLE INSERT 3-1/2" X 4-1/2" ID
66	PT26418066	SPINDLE 16MM X 9"
67	PT26418067	FLAT WASHER 5/8
68	PT26418068	SANDING SLEEVE 2" X 9" 100-GRIT
69	PT26418069	SANDING SLEEVE 3" X 9" 100-GRIT
70	PT26418070	SANDING DRUM 2" X 9" (RUBBER)
71	PT26418071	SANDING DRUM 3" X 9" (RUBBER)
72	PT26418072	WRENCH 19 X 22MM OPEN-ENDS



T26418 Oscillator Assembly

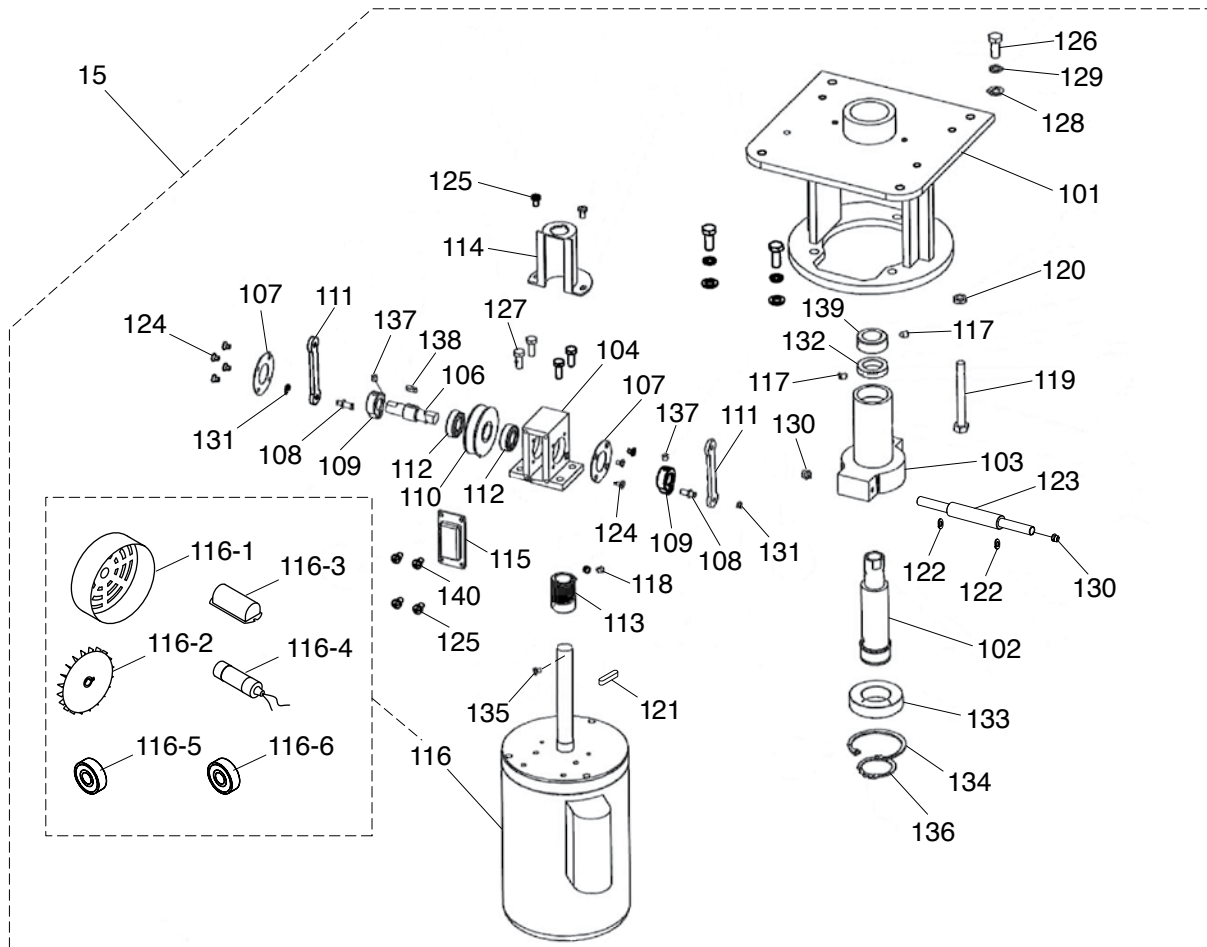

REF	PART #	DESCRIPTION
15	PT26418015	OSCILLATOR ASSEMBLY
101	PT26418101	MOTOR MOUNT
102	PT26418102	SPINDLE BASE
103	PT26418103	QUILL
104	PT26418104	OSCILLATOR BRACKET
106	PT26418106	OSCILLATOR SHAFT
107	PT26418107	END PLATE
108	PT26418108	CRANK SHAFT
109	PT26418109	ECCENTRIC LOCK COLLAR
110	PT26418110	WORM WHEEL
111	PT26418111	SWING ARM
112	PT26418112	BALL BEARING 6001ZZ
113	PT26418113	WORM
114	PT26418114	WORM COVER
115	PT26418115	BRACKET FRONT PLATE
116	PT26418116	MOTOR 1HP 110V 1-PH
116-1	PT26418116-1	MOTOR FAN COVER
116-2	PT26418116-2	MOTOR FAN
116-3	PT26418116-3	JUNCTION BOX W/COVER
116-4	PT26418116-4	S CAPACITOR 45M 300V 44 X 80MM
116-5	PT26418116-5	BALL BEARING 6204ZZ
116-6	PT26418116-6	BALL BEARING 6205ZZ
117	PT26418117	SET SCREW M6-1 X 6 DOG-PT

REF	PART #	DESCRIPTION
118	PT26418118	SET SCREW M6-1 X 6 DOG-PT
119	PT26418119	HEX BOLT M8-1.25 X 85
120	PT26418120	HEX NUT M8-1.25 THIN
121	PT26418121	KEY 6 X 6 X 50
122	PT26418122	LOCK WASHER 5MM
123	PT26418123	SWING ARM SHAFT
124	PT26418124	FLAT HD SCR M4-.7 X 6
125	PT26418125	PHLP HD SCR M5-.8 X 8
126	PT26418126	HEX BOLT M8-1.25 X 20
127	PT26418127	HEX BOLT M6-1 X 16
128	PT26418128	FLAT WASHER 8MM
129	PT26418129	LOCK WASHER 8MM
130	PT26418130	LOCK NUT M5-.8
131	PT26418131	E-CLIP 5MM
132	PT26418132	BALL BEARING 6805ZZ
133	PT26418133	BALL BEARING 6007ZZ
134	PT26418134	INT RETAINING RING 62MM
135	PT26418135	FLAT HD SCR M4-.7 X 16
136	PT26418136	EXT RETAINING RING 35MM
137	PT26418137	SET SCREW M5-.8 X 6 DOG-PT
138	PT26418138	KEY 4 X 4 X 12
139	PT26418139	QUILL DUST SEAL
140	PT26418140	PHLP HD SCR M4-.7 X 8



T26418 Machine Labels & Cosmetics

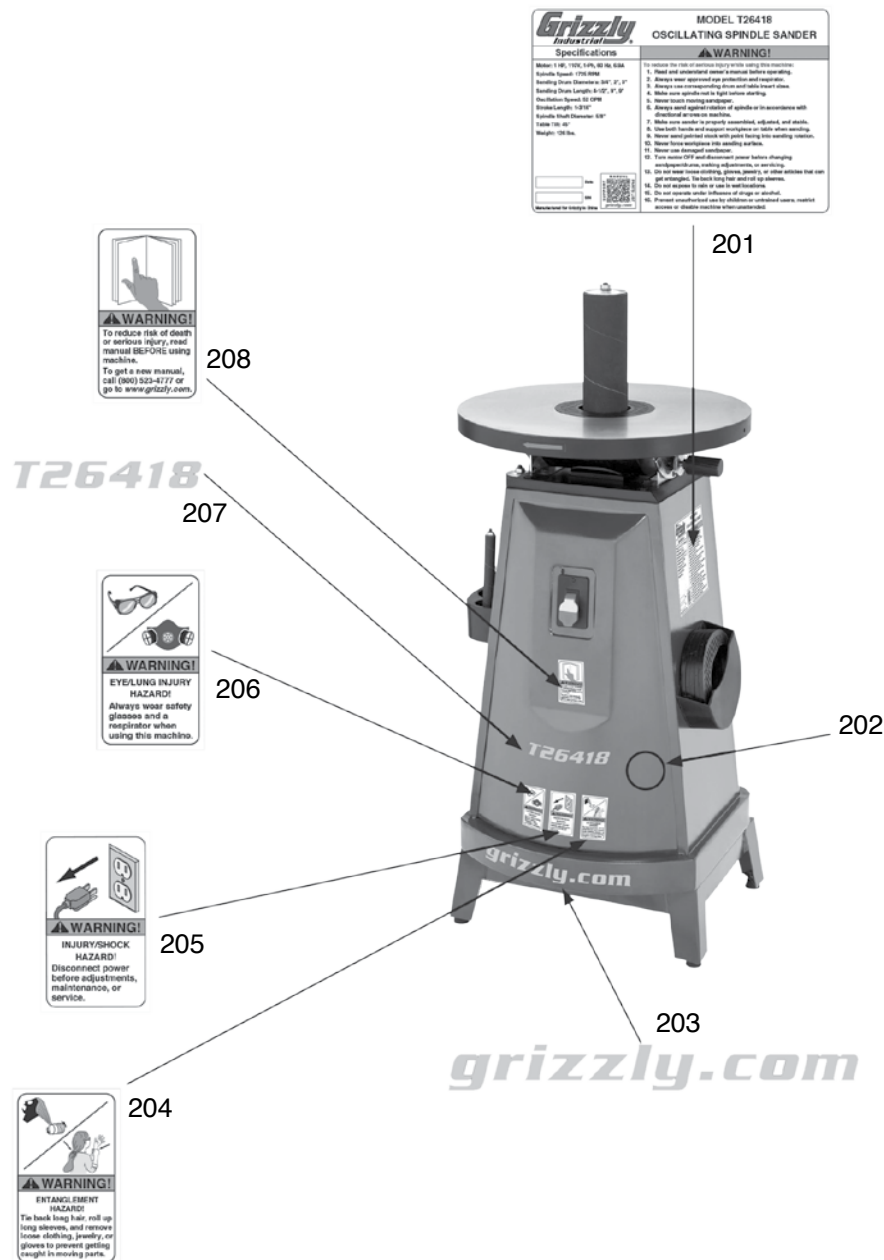

REF	PART #	DESCRIPTION
201	PT26418201	MACHINE ID LABEL
202	PT26418202	GRIZZLY GREEN TOUCH-UP PAINT
203	PT26418203	GRIZZLY.COM LABEL
204	PT26418204	ENTANGLEMENT HAZARD LABEL

REF	PART #	DESCRIPTION
205	PT26418205	DISCONNECT WARNING LABEL
206	PT26418206	EYE/LUNG HAZARD LABEL
207	PT26418207	MODEL NUMBER LABEL
208	PT26418208	READ MANUAL LABEL

⚠ WARNING

Safety labels help reduce the risk of serious injury caused by machine hazards. If any label comes off or becomes unreadable, the owner of this machine **MUST** replace it in the original location before resuming operations. For replacements, contact (800) 523-4777 or www.grizzly.com.





WARRANTY CARD

Name _____
 Street _____
 City _____ State _____ Zip _____
 Phone # _____ Email _____
 Model # _____ Order # _____ Serial # _____

The following information is given on a voluntary basis. It will be used for marketing purposes to help us develop better products and services. **Of course, all information is strictly confidential.**

1. How did you learn about us?

Advertisement Friend Catalog
 Card Deck Website Other:

2. Which of the following magazines do you subscribe to?

<input type="checkbox"/> Cabinetmaker & FDM	<input type="checkbox"/> Popular Science	<input type="checkbox"/> Wooden Boat
<input type="checkbox"/> Family Handyman	<input type="checkbox"/> Popular Woodworking	<input type="checkbox"/> Woodshop News
<input type="checkbox"/> Hand Loader	<input type="checkbox"/> Precision Shooter	<input type="checkbox"/> Woodsmith
<input type="checkbox"/> Handy	<input type="checkbox"/> Projects in Metal	<input type="checkbox"/> Woodwork
<input type="checkbox"/> Home Shop Machinist	<input type="checkbox"/> RC Modeler	<input type="checkbox"/> Woodworker West
<input type="checkbox"/> Journal of Light Cont.	<input type="checkbox"/> Rifle	<input type="checkbox"/> Woodworker's Journal
<input type="checkbox"/> Live Steam	<input type="checkbox"/> Shop Notes	<input type="checkbox"/> Other:
<input type="checkbox"/> Model Airplane News	<input type="checkbox"/> Shotgun News	
<input type="checkbox"/> Old House Journal	<input type="checkbox"/> Today's Homeowner	
<input type="checkbox"/> Popular Mechanics	<input type="checkbox"/> Wood	

3. What is your annual household income?

\$20,000-\$29,000 \$30,000-\$39,000 \$40,000-\$49,000
 \$50,000-\$59,000 \$60,000-\$69,000 \$70,000+

4. What is your age group?

20-29 30-39 40-49
 50-59 60-69 70+

5. How long have you been a woodworker/metalworker?

0-2 Years 2-8 Years 8-20 Years 20+ Years

6. How many of your machines or tools are Grizzly?

0-2 3-5 6-9 10+

7. Do you think your machine represents a good value? Yes No

8. Would you recommend Grizzly Industrial to a friend? Yes No

9. Would you allow us to use your name as a reference for Grizzly customers in your area?
Note: We never use names more than 3 times. Yes No

10. Comments: _____

CUT ALONG DOTTED LINE

FOLD ALONG DOTTED LINE



Place
Stamp
Here



GRIZZLY INDUSTRIAL, INC.
P.O. BOX 2069
BELLINGHAM, WA 98227-2069



FOLD ALONG DOTTED LINE

Send a Grizzly Catalog to a friend:

Name _____
Street _____
City _____ State _____ Zip _____

TAPE ALONG EDGES--PLEASE DO NOT STAPLE

WARRANTY & RETURNS

Grizzly Industrial, Inc. warrants every product it sells for a period of **1 year** to the original purchaser from the date of purchase. This warranty does not apply to defects due directly or indirectly to misuse, abuse, negligence, accidents, repairs or alterations or lack of maintenance. This is Grizzly's sole written warranty and any and all warranties that may be implied by law, including any merchantability or fitness, for any particular purpose, are hereby limited to the duration of this written warranty. We do not warrant or represent that the merchandise complies with the provisions of any law or acts unless the manufacturer so warrants. In no event shall Grizzly's liability under this warranty exceed the purchase price paid for the product and any legal actions brought against Grizzly shall be tried in the State of Washington, County of Whatcom.

We shall in no event be liable for death, injuries to persons or property or for incidental, contingent, special, or consequential damages arising from the use of our products.

To take advantage of this warranty, contact us by mail or phone and give us all the details. We will then issue you a "Return Number," which must be clearly posted on the outside as well as the inside of the carton. We will not accept any item back without this number. Proof of purchase must accompany the merchandise.

The manufacturers reserve the right to change specifications at any time because they constantly strive to achieve better quality equipment. We make every effort to ensure that our products meet high quality and durability standards and we hope you never need to use this warranty.

Please feel free to write or call us if you have any questions about the machine or the manual.

Thank you again for your business and continued support. We hope to serve you again soon.

grizzly.com[®]

TOOL WEBSITE

Buy Direct and Save with Grizzly[®] – Trusted, Proven and a Great Value!
~Since 1983~

*Visit Our Website Today For
Current Specials!*

**ORDER
24 HOURS A DAY!
1-800-523-4777**



Free Manuals Download Website

<http://myh66.com>

<http://usermanuals.us>

<http://www.somanuals.com>

<http://www.4manuals.cc>

<http://www.manual-lib.com>

<http://www.404manual.com>

<http://www.luxmanual.com>

<http://aubethermostatmanual.com>

Golf course search by state

<http://golfingnear.com>

Email search by domain

<http://emailbydomain.com>

Auto manuals search

<http://auto.somanuals.com>

TV manuals search

<http://tv.somanuals.com>