

# *Grizzly* *Industrial, Inc.*®

## **MODEL G5394 STROKE SANDER OWNER'S MANUAL**



COPYRIGHT © NOVEMBER, 2008 BY GRIZZLY INDUSTRIAL, INC.  
**WARNING: NO PORTION OF THIS MANUAL MAY BE REPRODUCED IN ANY SHAPE  
OR FORM WITHOUT THE WRITTEN APPROVAL OF GRIZZLY INDUSTRIAL, INC.**  
#JB11315 PRINTED IN TAIWAN

# **WARNING!**

**This manual provides critical safety instructions on the proper setup, operation, maintenance and service of this machine/equipment.**

**Failure to read, understand and follow the instructions given in this manual may result in serious personal injury, including amputation, electrocution or death.**

**The owner of this machine/equipment is solely responsible for its safe use. This responsibility includes but is not limited to proper installation in a safe environment, personnel training and usage authorization, proper inspection and maintenance, manual availability and comprehension, application of safety devices, blade/cutter integrity, and the usage of personal protective equipment.**

**The manufacturer will not be held liable for injury or property damage from negligence, improper training, machine modifications or misuse.**

# **WARNING!**

**Some dust created by power sanding, sawing, grinding, drilling, and other construction activities contains chemicals known to the State of California to cause cancer, birth defects or other reproductive harm. Some examples of these chemicals are:**

- **Lead from lead-based paints.**
- **Crystalline silica from bricks, cement and other masonry products.**
- **Arsenic and chromium from chemically-treated lumber.**

**Your risk from these exposures varies, depending on how often you do this type of work. To reduce your exposure to these chemicals: Work in a well ventilated area, and work with approved safety equipment, such as those dust masks that are specially designed to filter out microscopic particles.**

# Table of Contents

<b>INTRODUCTION</b> .....	<b>2</b>	<b>SECTION 5: ACCESSORIES</b> .....	<b>26</b>
Manual Accuracy .....	2	<b>SECTION 6: MAINTENANCE</b> .....	<b>28</b>
Contact Info.....	2	Schedule .....	28
Functional Overview .....	2	Cleaning.....	28
Identification.....	3	Lubrication .....	28
Machine Data Sheet .....	4	<b>SECTION 7: SERVICE</b> .....	<b>30</b>
<b>SECTION 1: SAFETY</b> .....	<b>6</b>	Troubleshooting .....	30
Safety Instructions for Machinery .....	6	Table Bearings.....	32
Additional Safety for Stroke Sanders.....	8	Belt Tracking.....	32
<b>SECTION 2: CIRCUIT REQUIREMENTS</b> .....	<b>9</b>	Table Elevation Wear Pin Adjustment.....	33
220V Operation.....	9	<b>SECTION 8: WIRING</b> .....	<b>34</b>
<b>SECTION 3: SETUP</b> .....	<b>10</b>	Wiring Safety Instructions .....	34
Setup Safety .....	10	Wiring Diagram .....	35
Items Needed for Setup.....	10	<b>SECTION 9: PARTS</b> .....	<b>36</b>
Unpacking .....	10	Main Breakdown .....	36
Inventory .....	11	Main Parts List.....	37
Hardware Recognition Chart .....	13	Belt & Idler Wheel Assembly Breakdown ....	38
Clean Up .....	14	Belt Assembly Parts List.....	39
Site Considerations.....	14	Gearbox & Table Breakdown & Parts List...	40
Assembly .....	15	Labels Breakdown & Parts List.....	42
Machine Leveling.....	19	<b>WARRANTY AND RETURNS</b> .....	<b>45</b>
Dust Collection.....	20		
Test Run .....	20		
<b>SECTION 4: OPERATIONS</b> .....	<b>21</b>		
Operation Safety .....	21		
Basic Controls.....	21		
Table Movement.....	22		
Workstops .....	23		
Platen Press.....	23		
Belt Replacement.....	24		
Platen Press Movement.....	25		
Basic Operations.....	25		

# INTRODUCTION

---

---

## Manual Accuracy

---

---

We are proud to offer this manual with your new machine! We've made every effort to be exact with the instructions, specifications, drawings, and photographs of the machine we used when writing this manual. However, sometimes errors do happen and we apologize for them.

Also, owing to our policy of continuous improvement, **your machine may not exactly match the manual**. If you find this to be the case, and the difference between the manual and machine leaves you in doubt, immediately call our technical support for updates or clarification.

For your convenience, we always keep current Grizzly manuals and most updates available on our website at [www.grizzly.com](http://www.grizzly.com). Any updates to your machine will be reflected in these documents as soon as they are complete. Visit our site often to check for the latest updates!

## Contact Info

---

---

We stand behind our machines. If you have any service questions, parts requests or general questions about the machine, please call or write us at the location listed below.

Grizzly Industrial, Inc.  
1203 Lycoming Mall Circle  
Muncy, PA 17756  
Phone: (570) 546-9663  
Fax: (800) 438-5901  
E-Mail: [techsupport@grizzly.com](mailto:techsupport@grizzly.com)

If you have any comments regarding this manual, please write to us at the address below:

Grizzly Industrial, Inc.  
c/o Technical Documentation Manager  
P.O. Box 2069  
Bellingham, WA 98227-2069  
Email: [manuals@grizzly.com](mailto:manuals@grizzly.com)

## Functional Overview

---

---

The Model G5394 Stroke Sander is used to sand large workpieces such as tabletops or doors. The platen press is used to apply sanding pressure through the sanding belt and into the workpiece.

The sander is used by placing the workpiece on the table, pressing the sanding belt against the workpiece via the platen press, and moving the table in/out as needed to sand the entire top surface of the workpiece.



# Identification

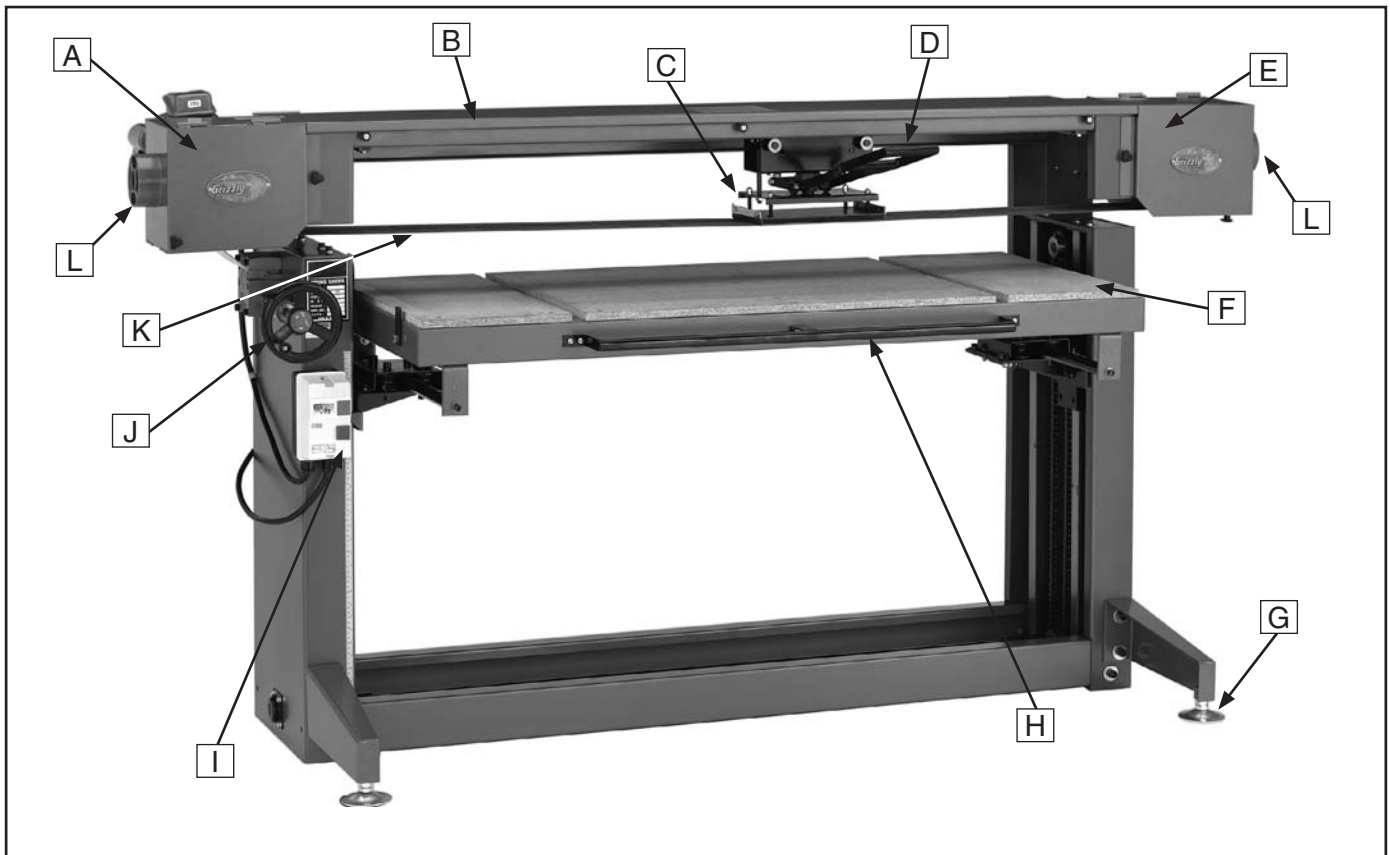

**Figure 1.** Identification.

- A. Drive Wheel Cover
- B. Sanding Belt Cover
- C. Platen Press
- D. Platen Press Handle
- E. Idler Wheel Cover
- F. Table
- G. Leveling Foot
- H. Table Handle
- I. Magnetic Switch
- J. Table Elevation Handwheel
- K. Sanding Belt
- L. Dust Port 4"



# MACHINE DATA SHEET

Customer Service #: (570) 546-9663 · To Order Call: (800) 523-4777 · Fax #: (800) 438-5901

## MODEL G5394 STROKE SANDER

### Product Dimensions:

Weight..... 608 lbs.  
 Length/Width/Height..... 93-3/4 x 38 x 50 in.  
 Foot Print (Length/Width)..... 70 x 30-1/2 in.

### Shipping Dimensions:

Type..... Cardboard/Wood Frame  
 Content..... Machine  
 Weight..... 690 lbs.  
 Length/Width/Height..... 28 x 74 x 26 in.

### Electrical:

Switch..... Magnetic with Thermal Overload Protector  
 Switch Voltage..... 220V  
 Cord Length..... 6 ft.  
 Cord Gauge..... 14 gauge  
 Minimum Circuit Size..... 20 amp  
 Plug Included..... No

### Motors:

#### Main

Type..... TEFC Capacitor Start Induction  
 Horsepower..... 3 HP  
 Voltage..... 220V  
 Prewired..... 220V  
 Phase..... Single  
 Amps..... 17A  
 Speed..... 1725 RPM  
 Cycle..... 60 Hz  
 Number Of Speeds..... 1  
 Power Transfer ..... Direct Drive  
 Bearings..... Shielded and Permanently Lubricated

### Main Specifications:

#### Table Info

Table Width..... 23-3/4 in.  
 Table Length..... 58 in.  
 Table Thickness..... 2-3/4 in.  
 Table Travel..... 18 in.  
 Table Height Adjustment..... 24 in.  
 Floor To Table Height..... 16 - 40 in.



**Belt Info**

Sanding Belt Width.....	6 in.
Sanding Belt Length.....	186 in.
Sanding Belt Speed.....	3500 FPM
Drive Roller Type.....	Aluminum
Drive Roller Length.....	6-3/4 in.
Drive Wheel Diameter.....	8 in.
Idler Roller Type.....	Aluminum
Idler Roller Length.....	6-3/4 in.
Idler Roller Diameter.....	8 in.

**Platen Info**

Platen Type.....	Graphite/Steel
Platen Length.....	10-1/2 in.
Platen Width.....	6 in.
Platen Travel.....	59 in.

**Construction**

Base Construction.....	Steel
Stand Construction.....	Steel
Table Construction.....	Steel Foundation with Particle Board Work Surface
Frame Construction.....	Steel
Paint.....	Powder Coated

**Other**

No. Of Dust Ports.....	2
Dust Port Size.....	4 in.

**Other Specifications:**

ISO Factory .....	ISO 9001
Country Of Origin .....	Taiwan
Warranty .....	1 Year
Serial Number Location .....	Machine Label Above On/Off Switch
Assembly Time .....	3 hours

**Features:**

- 24" Maximum Workpiece Thickness
- Handwheel Belt Tension
- 8" Aluminum Belt Drive Drums
- Sliding Ways Travel on Ball Bearings
- Platen Handle Swivels Left and Right
- Table Elevation is Manually Operated
- Fully Adjustable Belt Tracking and Tension



# SECTION 1: SAFETY

## WARNING

### For Your Own Safety, Read Instruction Manual Before Operating this Machine

The purpose of safety symbols is to attract your attention to possible hazardous conditions. This manual uses a series of symbols and signal words intended to convey the level of importance of the safety messages. The progression of symbols is described below. Remember that safety messages by themselves do not eliminate danger and are not a substitute for proper accident prevention measures.



Indicates an imminently hazardous situation which, if not avoided, **WILL** result in death or serious injury.



Indicates a potentially hazardous situation which, if not avoided, **COULD** result in death or serious injury.



Indicates a potentially hazardous situation which, if not avoided, **MAY** result in minor or moderate injury. It may also be used to alert against unsafe practices.

**NOTICE**

This symbol is used to alert the user to useful information about proper operation of the machine.

## WARNING

### Safety Instructions for Machinery

- 1. READ THE ENTIRE MANUAL BEFORE STARTING MACHINERY.** Machinery presents serious injury hazards to untrained users.
- 2. ALWAYS USE ANSI APPROVED SAFETY GLASSES WHEN OPERATING MACHINERY.** Everyday eyeglasses only have impact resistant lenses—they are NOT safety glasses.
- 3. ALWAYS WEAR A NIOSH APPROVED RESPIRATOR WHEN OPERATING MACHINERY THAT PRODUCES DUST.** Most types of dust (wood, metal, etc.) can cause severe respiratory illnesses.
- 4. ALWAYS USE HEARING PROTECTION WHEN OPERATING MACHINERY.** Machinery noise can cause permanent hearing loss.
- 5. WEAR PROPER APPAREL. DO NOT** wear loose clothing, gloves, neckties, rings, or jewelry that can catch in moving parts. Wear protective hair covering to contain long hair and wear non-slip footwear.
- 6. NEVER OPERATE MACHINERY WHEN TIRED OR UNDER THE INFLUENCE OF DRUGS OR ALCOHOL.** Be mentally alert at all times when running machinery.





# WARNING

## Safety Instructions for Machinery

7. **ONLY ALLOW TRAINED AND PROPERLY SUPERVISED PERSONNEL TO OPERATE MACHINERY.** Make sure operation instructions are safe and clearly understood.
8. **KEEP CHILDREN AND VISITORS AWAY.** Keep all children and visitors a safe distance from the work area.
9. **MAKE WORKSHOP CHILDPROOF.** Use padlocks, master switches, and remove start switch keys.
10. **NEVER LEAVE WHEN MACHINE IS RUNNING.** Turn power **OFF** and allow all moving parts to come to a complete stop before leaving machine unattended.
11. **DO NOT USE IN DANGEROUS ENVIRONMENTS.** DO NOT use machinery in damp, wet locations, or where any flammable or noxious fumes may exist.
12. **KEEP WORK AREA CLEAN AND WELL LIGHTED.** Clutter and dark shadows may cause accidents.
13. **USE A GROUNDED EXTENSION CORD RATED FOR THE MACHINE AMPERAGE.** Grounded cords minimize shock hazards. Undersized cords create excessive heat. Always replace damaged extension cords.
14. **ALWAYS DISCONNECT FROM POWER SOURCE BEFORE SERVICING MACHINERY.** Make sure switch is in OFF position before reconnecting.
15. **MAINTAIN MACHINERY WITH CARE.** Keep blades sharp and clean for best and safest performance. Follow instructions for lubricating and changing accessories.
16. **MAKE SURE GUARDS ARE IN PLACE AND WORK CORRECTLY BEFORE USING MACHINERY.**
17. **REMOVE ADJUSTING KEYS AND WRENCHES.** Make a habit of checking for keys and adjusting wrenches before turning machinery **ON**.
18. **CHECK FOR DAMAGED PARTS BEFORE USING MACHINERY.** Check for binding or misaligned parts, broken parts, loose bolts, and any other conditions that may impair machine operation. Repair or replace damaged parts before operation.
19. **USE RECOMMENDED ACCESSORIES.** Refer to the instruction manual for recommended accessories. Improper accessories increase risk of injury.
20. **DO NOT FORCE MACHINERY.** Work at the speed for which the machine or accessory was designed.
21. **SECURE WORKPIECE.** Use clamps or a vise to hold the workpiece when practical. A secured workpiece protects your hands and frees both hands to operate the machine.
22. **DO NOT OVERREACH.** Maintain stability and balance at all times.
23. **MANY MACHINES CAN EJECT WORKPIECES TOWARD OPERATOR.** Know and avoid conditions that cause the workpiece to "kickback."
24. **ALWAYS LOCK MOBILE BASES (IF USED) BEFORE OPERATING MACHINERY.**
25. **CERTAIN DUST MAY BE HAZARDOUS** to the respiratory systems of people and animals, especially fine dust. Be aware of the type of dust you are exposed to and always wear a respirator designed to filter that type of dust.



# **WARNING**

## **Additional Safety for Stroke Sanders**

- 1. RESPIRATOR AND SAFETY GLASSES.** Always wear a respirator and safety glasses while operating the machine. Dust and chips are created when sanding. Some debris will be ejected, becoming hazards to the eyes and lungs.
- 2. DUST COLLECTION SYSTEM.** Never operate the sander without an adequate dust collection system in place and running.
- 3. HAND PROTECTION.** DO NOT place hands near, or in contact with, sanding belt during operation. DO NOT allow fingers to get pinched between the workpiece and the table. This may pull the operator's hand into the machine and cause serious injury!
- 4. SANDING CORRECT MATERIAL.** Only sand natural wood stock with this sander. We do not recommend sanding MDF, particle board, laminates, plastics, metal, glass, ceramics, and any other synthetic products, or products containing asbestos or lead paint. Many of these products contain hazardous dust, or will greatly reduce the life of your sanding paper.
- 5. UNATTENDED OPERATION.** Never leave the machine running unattended.
- 6. CLOTHING.** DO NOT wear loose clothing while operating this machine. Roll up or button sleeves at the cuff.
- 7. REPLACING SANDPAPER.** Replace sanding belt when it becomes worn. DO NOT operate the sander with a damaged or badly worn sanding belt.
- 8. MAINTENANCE AND ADJUSTMENTS.** Perform machine inspections and maintenance service promptly when called for. Disconnect power before performing maintenance or adjustments on the sander.
- 9. EXPERIENCING DIFFICULTIES.** Any problem, with the exception of conveyor belt tracking that is concerned with any moving parts or accessories, must be investigated and corrected with the power disconnected, and after all moving parts have come to a complete stop.

# **WARNING**

Like all machinery there is potential danger when operating this machine. Accidents are frequently caused by lack of familiarity or failure to pay attention. Use this machine with respect and caution to decrease the risk of operator injury. If normal safety precautions are overlooked or ignored, serious personal injury may occur.



# SECTION 2: CIRCUIT REQUIREMENTS

## 220V Operation

### **!WARNING**

Serious personal injury could occur if you connect the machine to power before completing the setup process. **DO NOT** connect the machine to the power until instructed later in this manual.

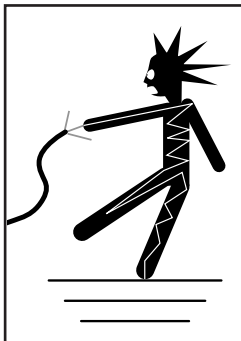

### **!WARNING**

Electrocution or fire could result if machine is not grounded and installed in compliance with electrical codes. Compliance **MUST** be verified by a qualified electrician!

### Full Load Amperage Draw

This machine draws the following amps under maximum load:

Amp Draw..... 17 Amps

### Power Supply Circuit Requirements

The power supply circuit for your machine **MUST** be grounded and rated for the amperage given below. Never replace a circuit breaker on an existing circuit with one of higher amperage without consulting a qualified electrician to ensure compliance with wiring codes. **If you are unsure about the wiring codes in your area or you plan to connect your machine to a shared circuit, consult a qualified electrician.**

Minimum Circuit Size.....20 Amps

### Power Connection Device

The type of plug required to connect your machine to power depends on the type of service you currently have or plan to install. We recommend using the plug shown in **Figure 2**.

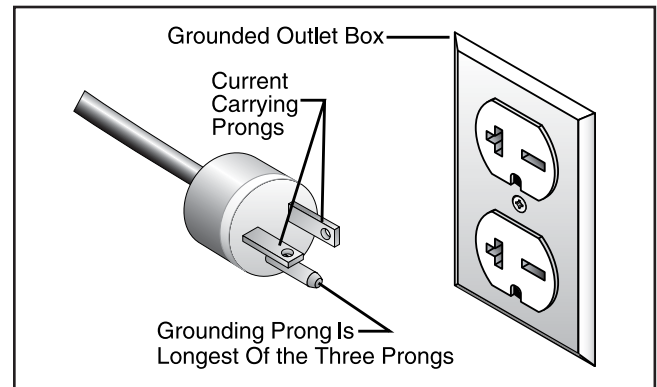

**Figure 2.** NEMA 6-20 plug and receptacle.

### Extension Cords

Using extension cords may reduce the life of the motor. Instead, place the machine near a power source. If you must use an extension cord:

- Use at least a 12 gauge cord that does not exceed 50 feet in length!
- The extension cord must also have a ground wire and plug pin.
- A qualified electrician **MUST** size cords over 50 feet long to prevent motor damage.



# SECTION 3: SETUP

## Setup Safety

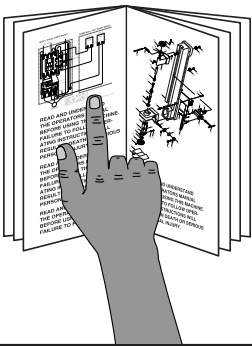

**⚠️ WARNING**  
 This machine presents serious injury hazards to untrained users. Read through this entire manual to become familiar with the controls and operations before starting the machine!



**⚠️ WARNING**  
 Wear safety glasses during the entire setup process!



**⚠️ WARNING**  
 This machine and its components are very heavy. Get lifting help or use power lifting equipment such as a forklift to move heavy items.

## Items Needed for Setup

The following items are needed to complete the setup process, but are not included with your machine:

Description	Qty
• Assistant.....	1
• Safety Glasses (For Each Person).....	1
• Square.....	1
• Dust Collection System.....	1
• 4" Flexible Dust Hoses.....	2
• 4" Hose Clamps.....	2
• Wrenches 10, 12mm, 3/4".....	1 Ea.
• Phillips Screwdriver.....	1

## Unpacking

Your machine was carefully packaged for safe transportation. Remove the packaging materials from around your machine and inspect it. If you discover the machine is damaged, *please immediately call Customer Service at (570) 546-9663 for advice.*

Save the containers and all packing materials for possible inspection by the carrier or its agent. *Otherwise, filing a freight claim can be difficult.*

When you are completely satisfied with the condition of your shipment, inventory the contents.



# Inventory

The following is a description of the main components shipped with your machine. Lay the components out to inventory them.

**Note:** If you can't find an item on this list, check the mounting location on the machine or examine the packaging materials carefully. Occasionally we pre-install certain components for shipping purposes.

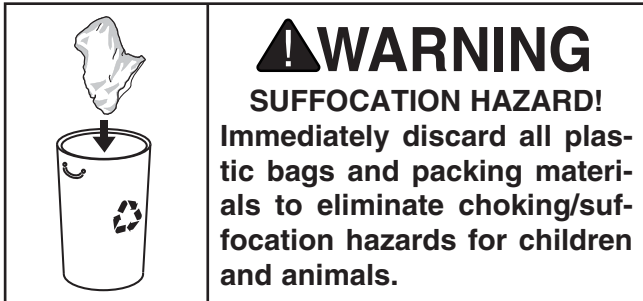

If any nonproprietary parts are missing (e.g. a nut or a washer), we will gladly replace them; or for the sake of expediency, replacements can be obtained at your local hardware store.

Uprights: (Figure 3)	Qty
A. Left Upright Assembly .....	1
B. Right Upright Assembly .....	1

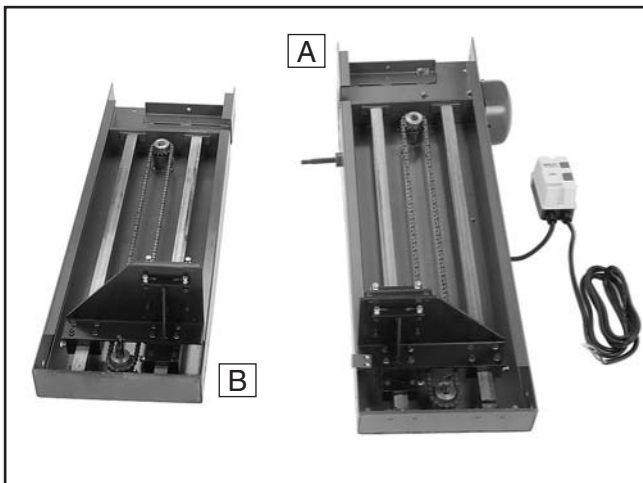

Figure 3. Uprights.

Frame Components: (Figure 4)	Qty
C. Platen Assembly .....	1
D. Elevation Rod .....	1
E. Top Frame Rail .....	1
F. Bottom Frame Rails .....	2
G. Right Foot .....	1
H. Left Foot .....	1

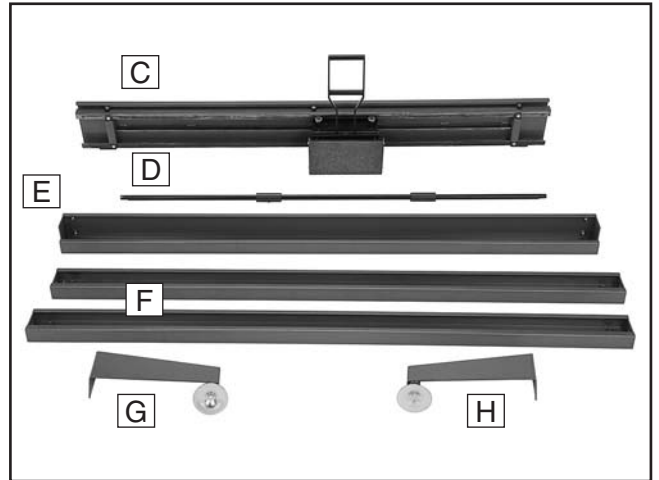

Figure 4. Frame Components.

Wheel Components: (Figure 5)	Qty
I. Idler Wheel Assembly .....	1
J. Idler Wheel Cover .....	1
K. Drive Wheel Cover .....	1

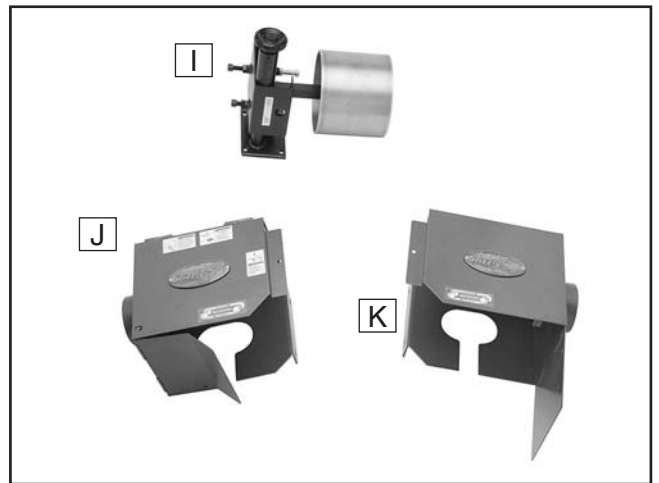
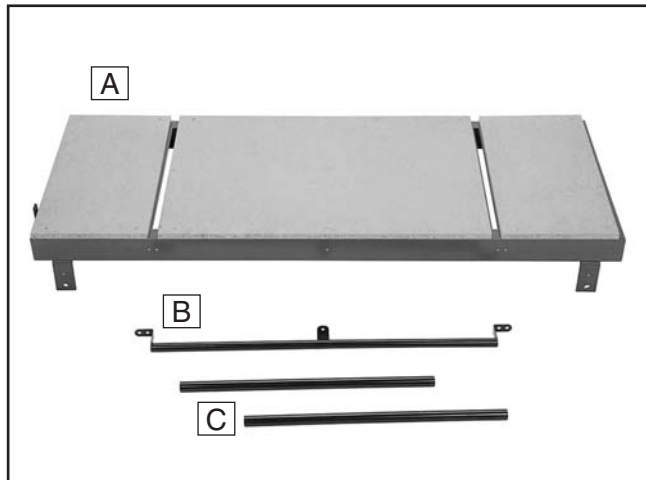

Figure 5. Wheel Components.

<b>Table Components: (Figure 6)</b>		<b>Qty</b>
<b>A.</b>	Table Assembly .....	1
<b>B.</b>	Table Handle .....	1
<b>C.</b>	Table Rods .....	2



**Figure 6.** Table Components.

<b>Additional Components: (Figure 7)</b>		<b>Qty</b>
<b>D.</b>	Sanding Belt 6" x 186" .....	1
<b>E.</b>	Elevation Handwheel.....	1

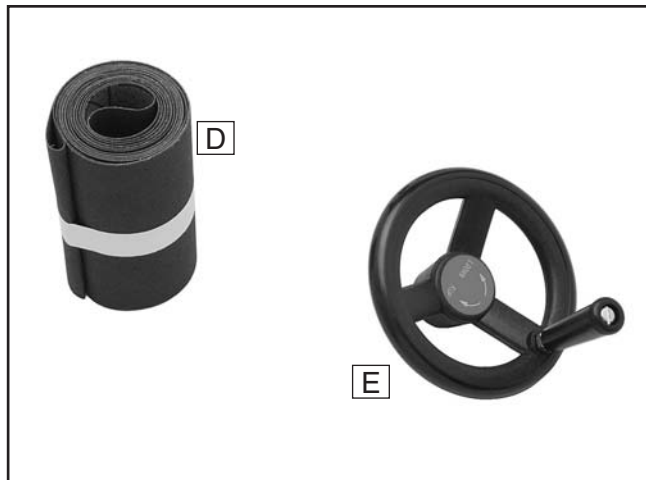

**Figure 7.** Additional Components.

<b>Hardware/Tools: (Figure 8)</b>		<b>Qty</b>
<b>F.</b>	Cap Screws $\frac{3}{8}$ "-16 x $\frac{3}{4}$ " (Frame, Table) ...	12
<b>G.</b>	Cap Screws $\frac{1}{2}$ "-13 x 1" (Frame) .....	10
<b>H.</b>	Flat Washers $\frac{1}{2}$ " (Frame) .....	10
<b>I.</b>	Lock Washers $\frac{3}{8}$ " (Frame, Table).....	12
<b>J.</b>	Flat Washers $\frac{3}{8}$ " (Frame, Table) .....	4
<b>K.</b>	Flat Washers $\frac{1}{4}$ " (Table Handle) .....	6
<b>L.</b>	Lock Washers $\frac{1}{4}$ " (Table Handle).....	6
<b>M.</b>	Flat Washers $\frac{5}{16}$ " (Wheel Covers).....	4
<b>N.</b>	Fender Washers $\frac{1}{4}$ " (Knobs) .....	6
<b>O.</b>	Hex Wrenches $\frac{5}{32}$ ", $\frac{3}{16}$ ", $\frac{7}{32}$ ", $\frac{5}{16}$ ", $\frac{3}{8}$ "..	1 Ea.
<b>P.</b>	Flange Bolts $\frac{1}{4}$ "-20 x $\frac{1}{2}$ " (Platen).....	6
<b>Q.</b>	Phillips Head Screws $\frac{1}{4}$ "-20 x $\frac{3}{8}$ " (Handle) 5	
<b>R.</b>	Flange Bolt $\frac{5}{16}$ "-18 x $\frac{3}{4}$ " (Motor Mount) .....	1
<b>S.</b>	Flange Bolts $\frac{5}{16}$ "-18 x 1" (Idler Wheel) .....	4
<b>T.</b>	Flange Bolts $\frac{5}{16}$ "-18 x $\frac{1}{2}$ " (Wheel Covers) .	4
<b>U.</b>	Knobs $\frac{1}{4}$ "-20 x $\frac{1}{2}$ " (Wheel Covers) .....	6

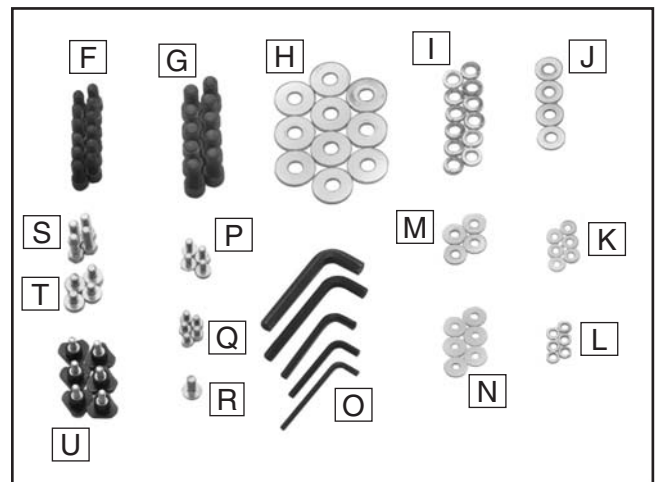

**Figure 8.** Hardware/tools.

**Note:** Extra fasteners are included with the machine. You may be left with extra hardware after assembly is complete.



# Hardware Recognition Chart

USE THIS CHART TO MATCH UP HARDWARE DURING THE ASSEMBLY PROCESS.

MEASURE BOLT DIAMETER BY PLACING INSIDE CIRCLE

- #10
- 1/4"
- 5/16"
- 3/8"
- 7/16"
- 1/2"

- 4mm
- 6mm
- 8mm
- 10mm
- 12mm
- 16mm

LINES ARE 1MM APART

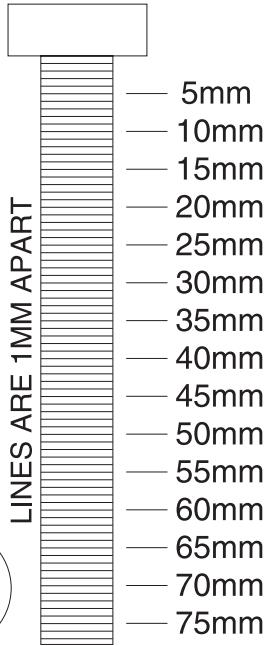

LINES ARE 1/16" INCH APART

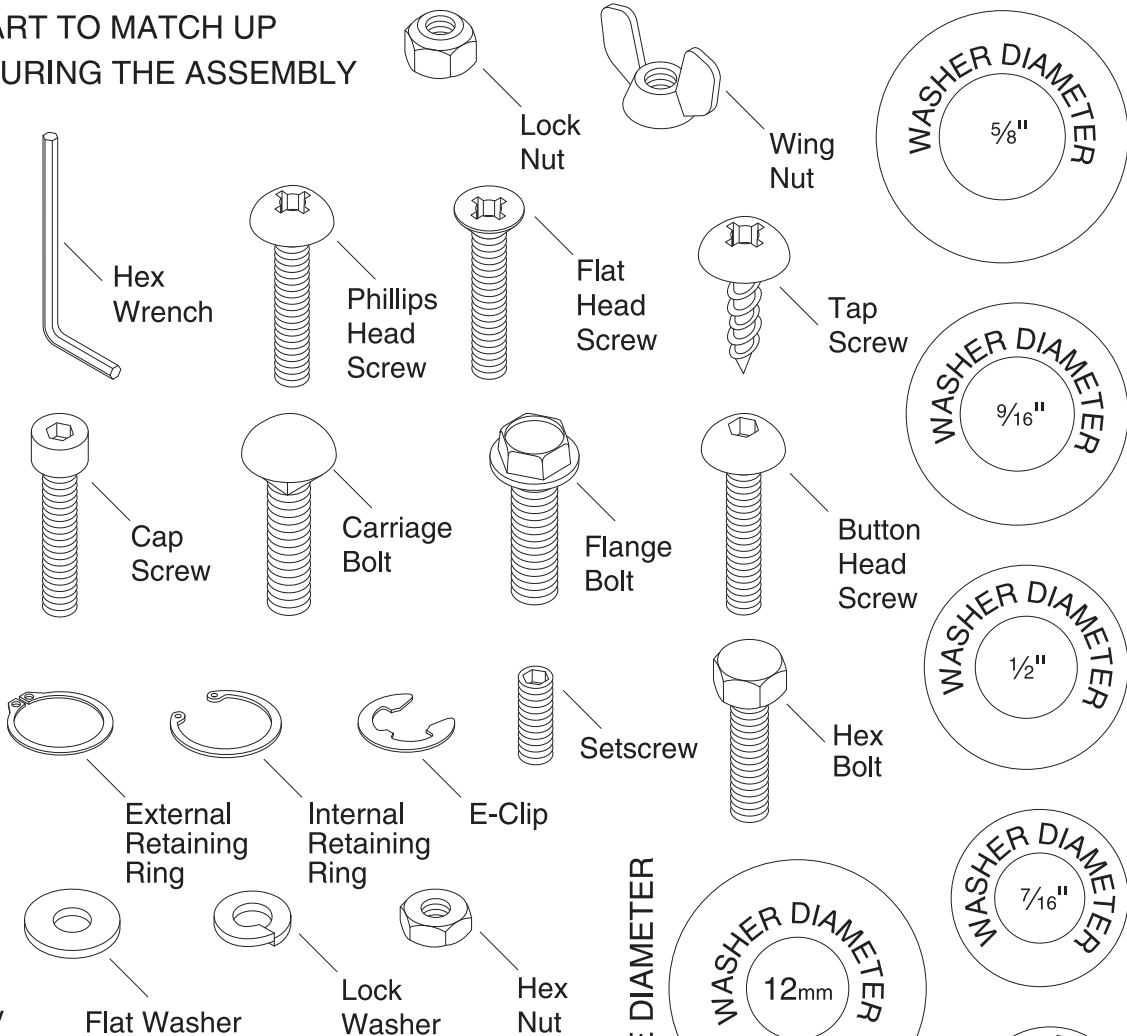
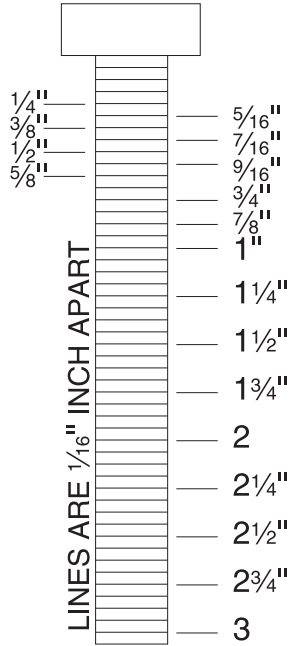

WASHERS ARE MEASURED BY THE INSIDE DIAMETER

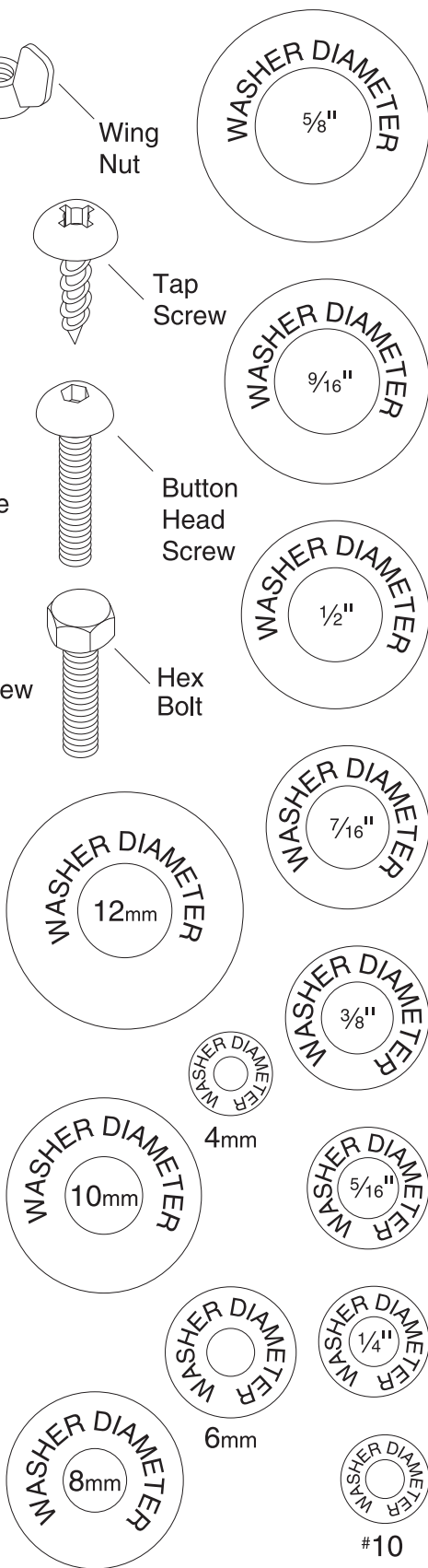

# Clean Up

The unpainted surfaces are coated with a waxy oil to prevent corrosion during shipment. Remove this protective coating with a solvent cleaner or degreaser, such as shown in **Figure 9**. For thorough cleaning, some parts must be removed. **For optimum performance, clean all moving parts or sliding contact surfaces.** Avoid chlorine-based solvents, such as acetone or brake parts cleaner that may damage painted surfaces. Always follow the manufacturer's instructions when using any type of cleaning product.

	<p><b>! WARNING</b> Gasoline and petroleum products have low flash points and can explode or cause fire if used to clean machinery. <b>DO NOT</b> use these products to clean the machinery.</p>
---	--

	<p><b>! CAUTION</b> Many cleaning solvents are toxic if inhaled. Minimize your risk by only using these products in a well ventilated area.</p>
---	---

**G2544—Solvent Cleaner & Degreaser**  
**H9692—Orange Power Degreaser**  
 Great products for removing shipping grease.



**Figure 9.** Cleaner/degreasers available from Grizzly.

# Site Considerations

## Floor Load

Refer to the **Machine Data Sheet** for the weight and footprint specifications of your machine. Some residential floors may require additional reinforcement to support both the machine and operator.

## Placement Location

Consider existing and anticipated needs, size of material to be processed through each machine, and space for auxiliary stands, work tables or other machinery when establishing a location for your new machine. See **Figure 10** for the minimum working clearances.

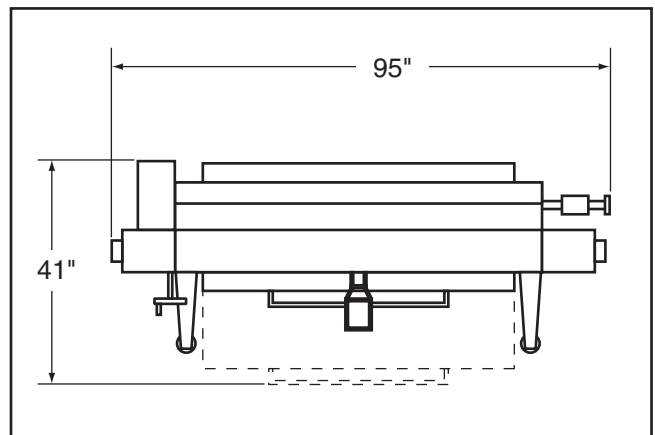

**Figure 10.** Minimum working clearances.

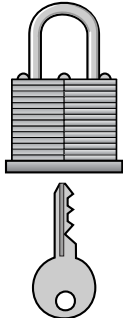
	<p><b>! CAUTION</b> Children and visitors may be seriously injured if unsupervised around this machine. Lock entrances to the shop or disable start switch or power connection to prevent unsupervised use.</p>
--	---





# Assembly

After you have removed all of the components from the shipping crate and checked the inventory, assemble the machine.

## To assemble your machine:

1. Attach the left foot assembly to the left upright with (1)  $\frac{3}{8}$ "-16 x  $\frac{3}{4}$ " cap screw and (1)  $\frac{3}{8}$ " flat washer, as shown in **Figure 11**. Do not yet fully tighten the cap screw.

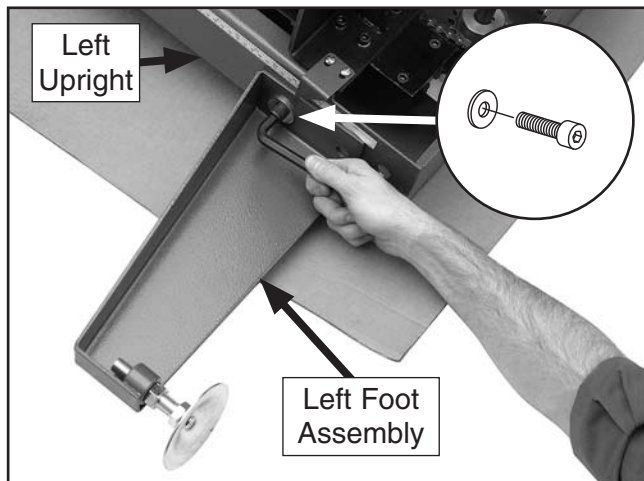

**Figure 11.** Foot assembly attachment.

2. Repeat **Step 1** for the right foot assembly and right upright.

3. Lay the left upright on a piece of cardboard, as shown in **Figure 12**. Attach the two bottom frame rails with (4)  $\frac{3}{8}$ "-16 x  $\frac{3}{4}$ " cap screws and (4)  $\frac{3}{8}$ " flat washers.

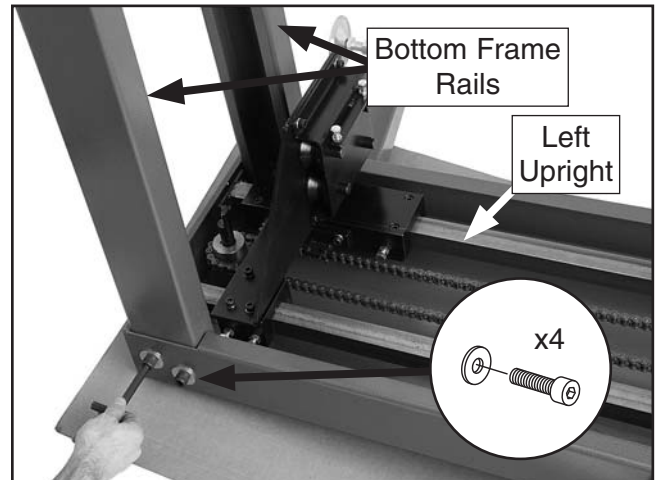

**Figure 12.** Second upright assembly.

4. Lift the left upright so it stands vertically with the frame rails against the floor, and attach the right upright with the remaining (4)  $\frac{3}{8}$ "-16 x  $\frac{3}{4}$ " cap screws and (4)  $\frac{3}{8}$ " flat washers (**Figure 13**).

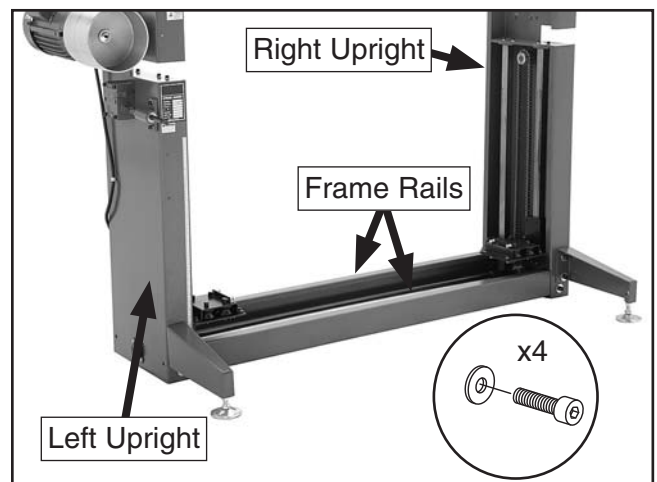

**Figure 13.** Third cross brace.

- Attach the top frame rail to the top of the uprights with (4)  $\frac{3}{8}$ "-16 x  $\frac{3}{4}$ " cap screws and (4)  $\frac{3}{8}$ " lock washers, as shown in **Figure 14**. Do not yet fully tighten the cap screws.

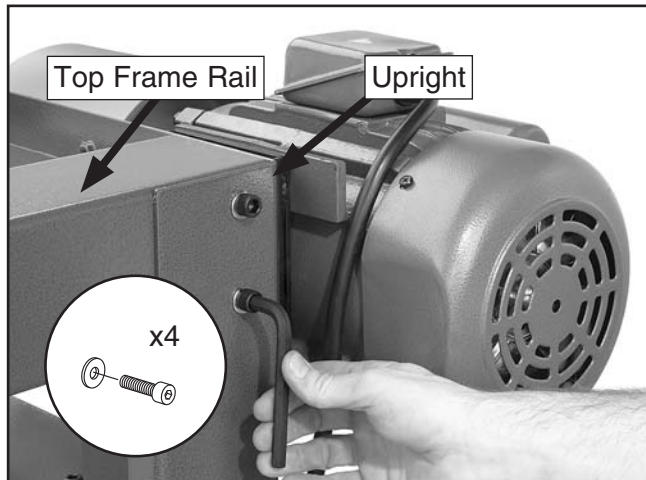

**Figure 14.** Top rail attachment.

- Insert the  $\frac{5}{16}$ "-18 x  $\frac{3}{4}$ " flange bolt through the motor bracket, upright frame, and into the top rail, as shown in **Figure 15**. Do not yet fully tighten the flange bolt.

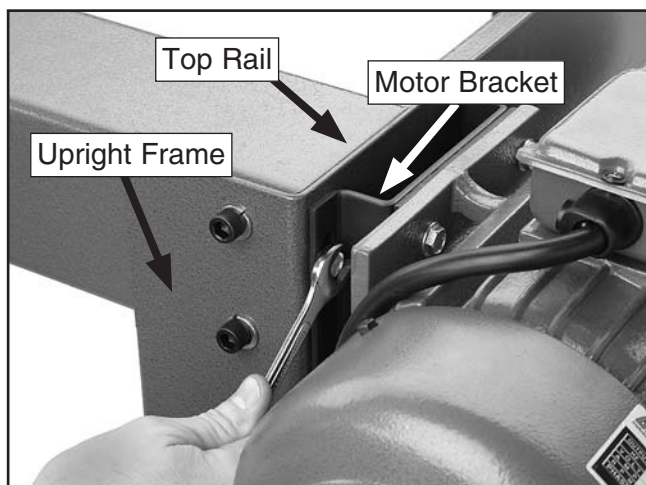

**Figure 15.** Motor bolt.

- With the help of an assistant, place the platen assembly onto the assembled frame, then secure it with (4)  $\frac{1}{4}$ "-20 x  $\frac{1}{2}$ " flange bolts and (4)  $\frac{1}{4}$ " flat washers, as shown in **Figure 16**. Do not yet fully tighten the flange bolts.

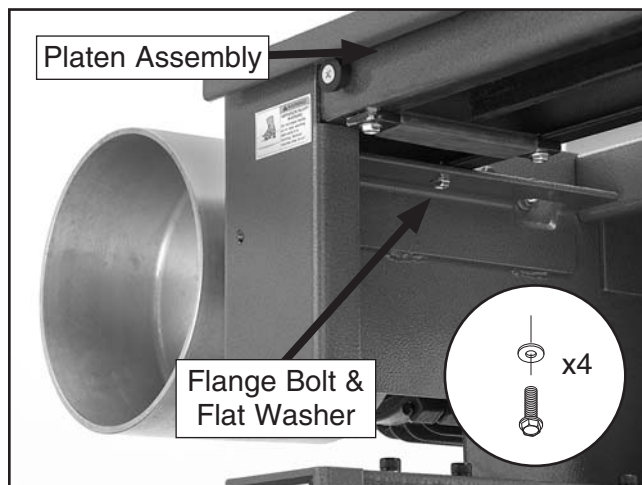

**Figure 16.** Platen assembly.

- Use a precision square to square the machine both vertically and horizontally, then tighten all of the hardware.
- Attach the table elevation rod to both upright assemblies by aligning the rods, then sliding the coupler over the joint and securing the set screw.

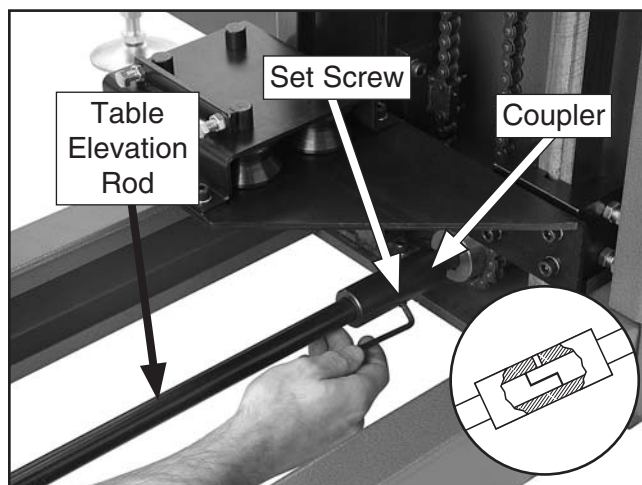

**Figure 17.** Table elevation rod.

**Note:** To make sure both sides are set evenly, fully lower both before connecting the table elevation rod.

- Slide the table rods into the table rollers, as shown in **Figure 18**.

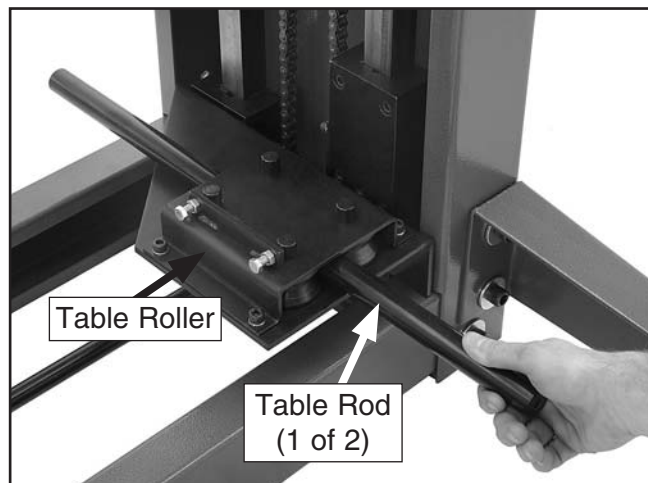

**Figure 18.** Inserting table rods.

- Place the table assembly over the table rods, then attach it with (4)  $\frac{3}{8}$ "-16 x  $\frac{3}{4}$ " cap screws, (4)  $\frac{3}{8}$ " lock washers and (4)  $\frac{3}{8}$ " flat washers, as shown in **Figure 19**.

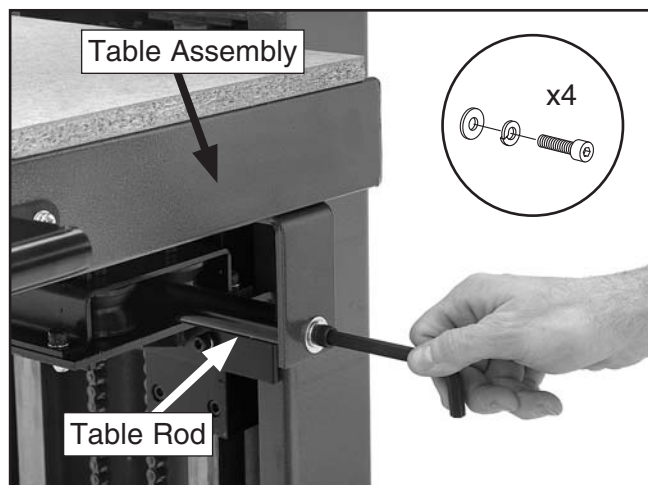

**Figure 19.** Attaching table.

- Connect the idler wheel assembly to the right upright with (4)  $\frac{5}{16}$ "-18 x 1" flange bolts, as shown in **Figure 20**.

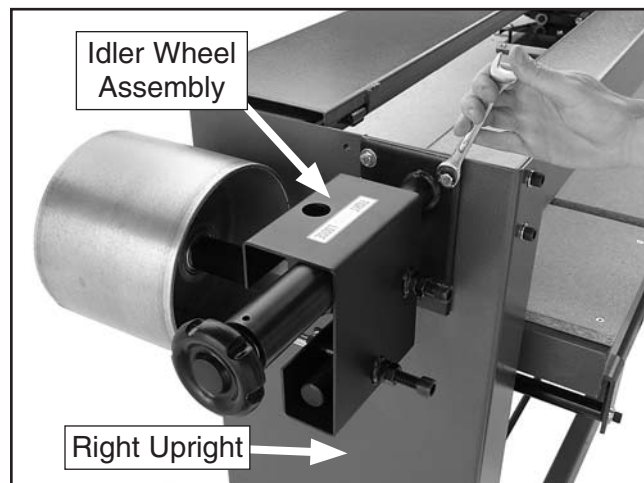
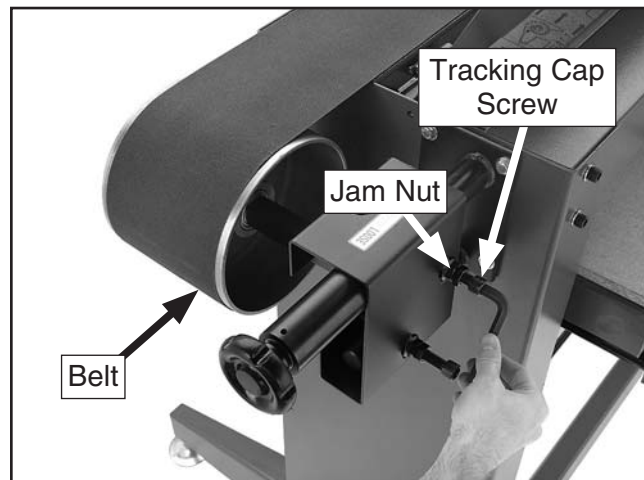

**Figure 20.** Idler wheel assembly.

- Place the belt over both wheels, orienting it so the arrow printed on the back indicates that the surface nearest the table will move from right to left. Use the tension knob to tension the belt so it sags less than  $\frac{1}{2}$ ".
- Put on gloves, then check the tracking by spinning the idler wheel.

—If the belt stays centered on the idler wheel, no further action is necessary.

—If the belt wanders to either side of the idler wheel, loosen the jam nut and turn the cap tracking cap screw (**Figure 21**) until the belt tracks centered on the idler wheel, then tighten the jam nut.



**Figure 21.** Belt tracking.

15. Attach the idler wheel cover to the right upright with (2)  $\frac{5}{16}$ "-18 x  $\frac{1}{2}$ " flange bolts and (2)  $\frac{5}{16}$ " flat washers (**Figure 22**).

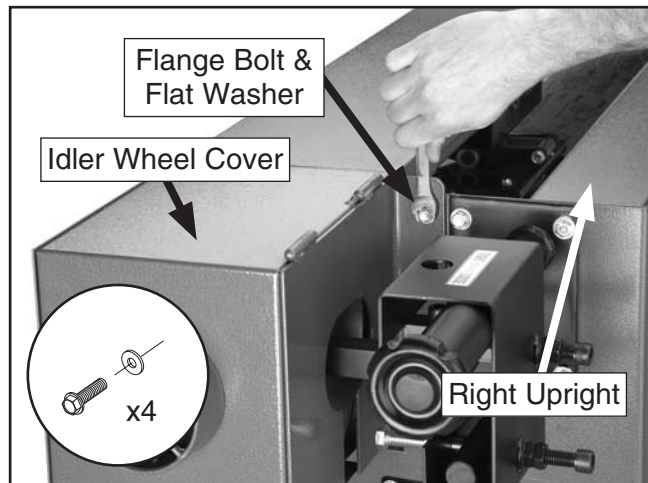

**Figure 22.** Idler wheel cover.

16. Close the idler wheel cover doors and secure them with (3)  $\frac{1}{4}$ "-20 x  $\frac{1}{2}$ " knobs and  $\frac{1}{4}$ " flat washers (**Figure 23**).

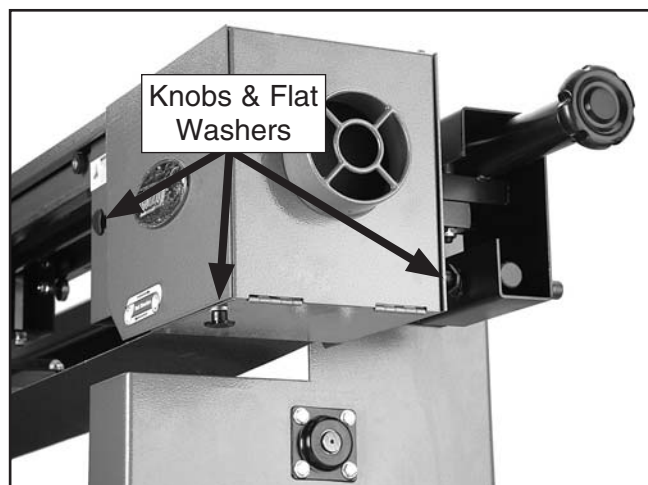

**Figure 23.** Knob placement.

17. Repeat **Steps 15–16** for the drive wheel cover on the left side of the machine.

18. Remove the gearbox shaft bracket by unthreading the (2) cap screws, sliding it over the shaft, then attaching it with the removed cap screws (**Figure 24**).

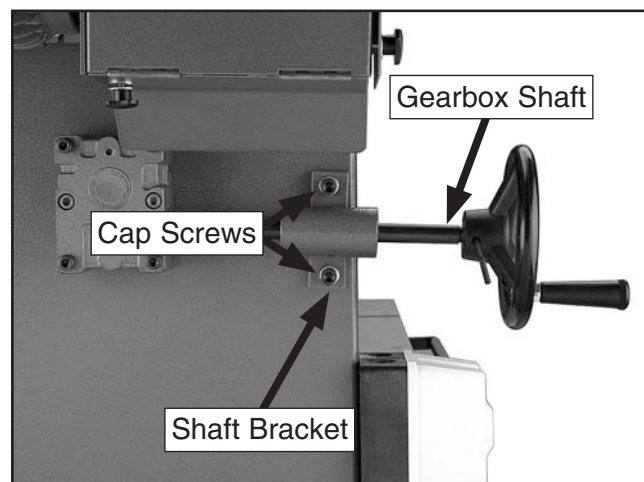

**Figure 24.** Gearbox shaft.

19. Attach the elevation handwheel by aligning the flat portion of the shaft with the set screw on the handwheel, then sliding the handwheel over the shaft and tightening the set screw (**Figure 25**).

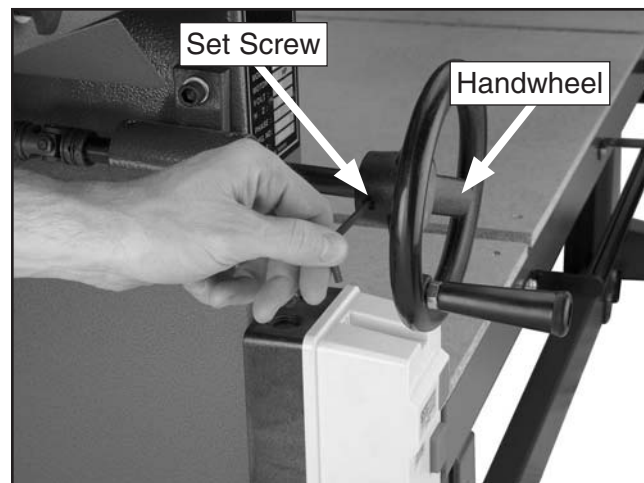

**Figure 25.** Handwheel placement.



20. Remove the plastic screws that secure the switch box cover, then use the pre-installed screws to attach the switch box to the left upright, as shown in **Figure 26**.

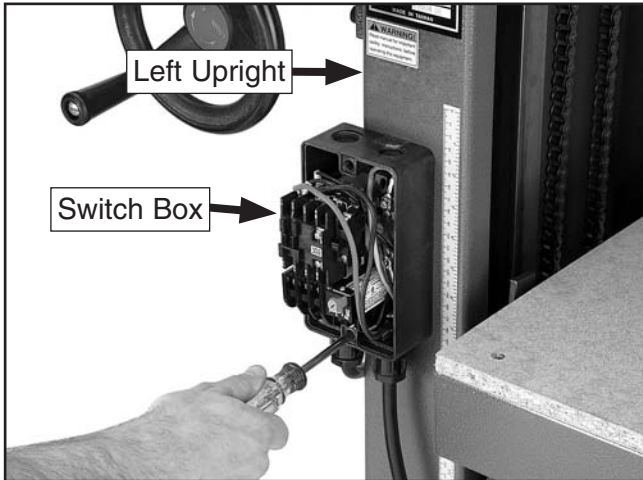

**Figure 26.** Switch box mounting.

21. Replace the switch box cover with the plastic screws removed in the previous step (**Figure 27**).



**Figure 27.** Replacing cover.

22. Attach the table handle to the table with (5) 1/4"-20 x 1/2" Phillips head screws, (5) 1/4" lock washers and (5) 1/4" flat washers (**Figure 28**).

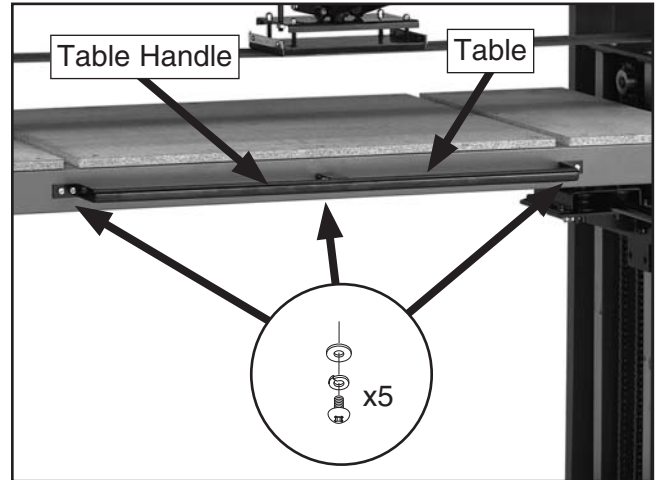

**Figure 28.** Attaching handle.

## Machine Leveling

Once assembly is complete, move your machine into position, then level it. Use a level to check from side-to-side and front-to-back.

To adjust for level from side-to-side, use shims under the uprights of the machine.

To level from front-to-back, use the leveling feet. Thread each foot in or out as necessary, then tighten the jam nut to secure it in position (**Figure 29**).

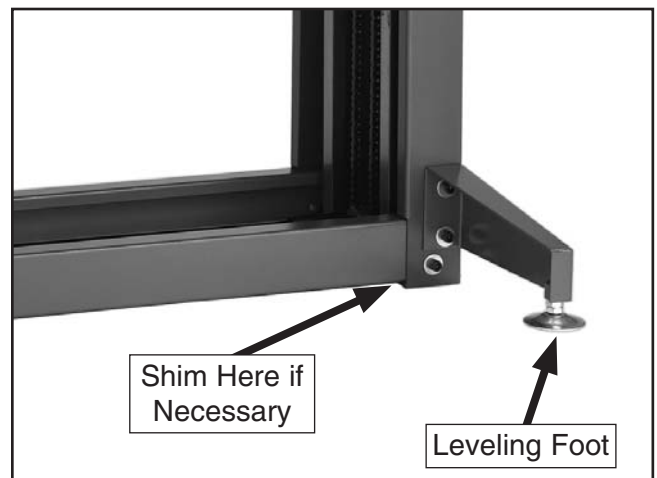

**Figure 29.** Machine leveling.

# Dust Collection

## CAUTION

**DO NOT** operate the Model G5394 without an adequate dust collection system. This sander creates substantial amounts of wood dust while operating. Failure to use a dust collection system can result in short and long-term respiratory illness.

### Required CFM at each Dust Port: 400 CFM

*Do not confuse this CFM recommendation with the rating of the dust collector. To determine the CFM at the dust port, you must consider these variables: (1) CFM rating of the dust collector, (2) hose type and length between the dust collector and the machine, (3) number of branches or wyes, and (4) amount of other open lines throughout the system. Explaining how to calculate these variables is beyond the scope of this manual. Consult an expert or purchase a good dust collection "how-to" book.*

### To connect the dust collection hoses:

1. Fit 4" flexible dust hoses over the dust ports located at each end of the belt assembly, as shown in **Figure 30**, and secure them in place with hose clamps.



**Figure 30.** Dust hose attached to dust port.

2. Tug the hoses to make sure they do not come off. A tight fit is necessary for proper performance.

# Test Run

Once the assembly is complete, test run your machine to make sure it runs properly.

If, during the test run, you cannot easily locate the source of an unusual noise or vibration, stop using the machine immediately, then review the **Troubleshooting** on **Page 30**.

If you still cannot remedy a problem, contact our Tech Support at (570) 546-9663 for assistance.

### To test run the machine:

1. Make sure you have read the safety instructions at the beginning of the manual and that the machine is setup properly.
2. Make sure all tools and objects used during setup are cleared away from the machine.
3. Connect the machine to the power source.
4. Use the tension handwheel to tension the belt so that there is less than 1/2" of sag along its length.
5. Turn the machine **ON**.
6. Listen and watch for abnormal noises or actions. The machine should run smoothly with little or no vibration or rubbing noises.

—Strange or unusual noises should be investigated and corrected before operating the machine further. Always disconnect the machine from power when investigating or correcting potential problems.

7. Turn the machine **OFF**.

# SECTION 4: OPERATIONS

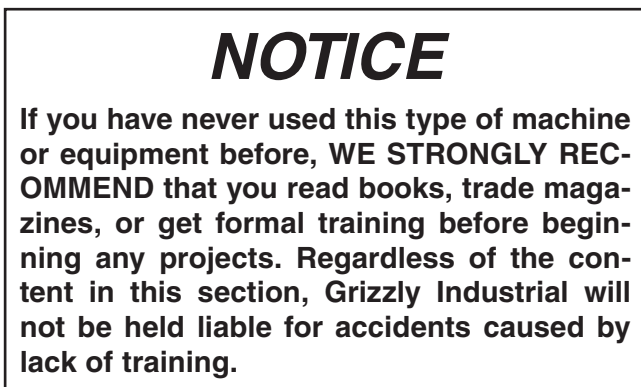
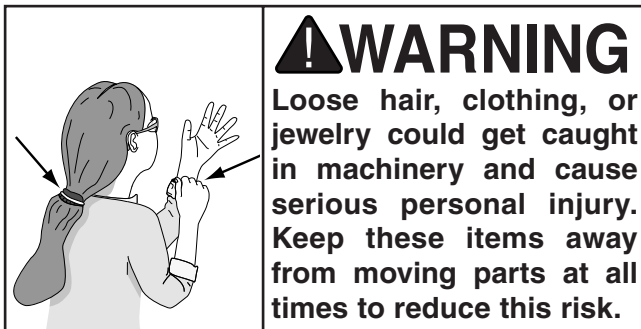
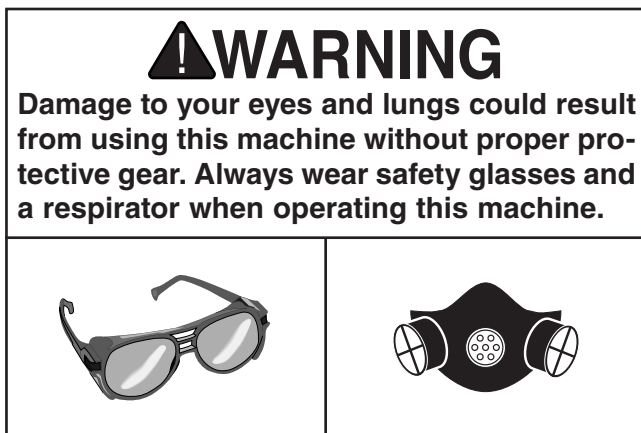
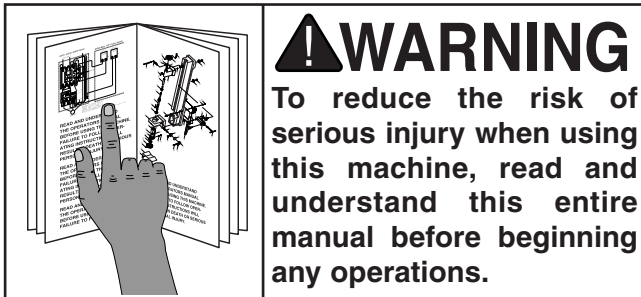

## Basic Controls

Use **Figures 31–32** and the descriptions below to become familiar with the basic controls of the machine.

**ON/OFF Switch:** Turns the motor ON/OFF.

**Table Elevation Handwheel:** Raises and lowers the table to allow for different size workpieces.

**Table Work Stop:** Can be raised to provide workpiece stability and prevent kickback, and can be lowered for larger workpieces.

**Table Depth Indicator:** Displays the distance between the table surface and the belt.

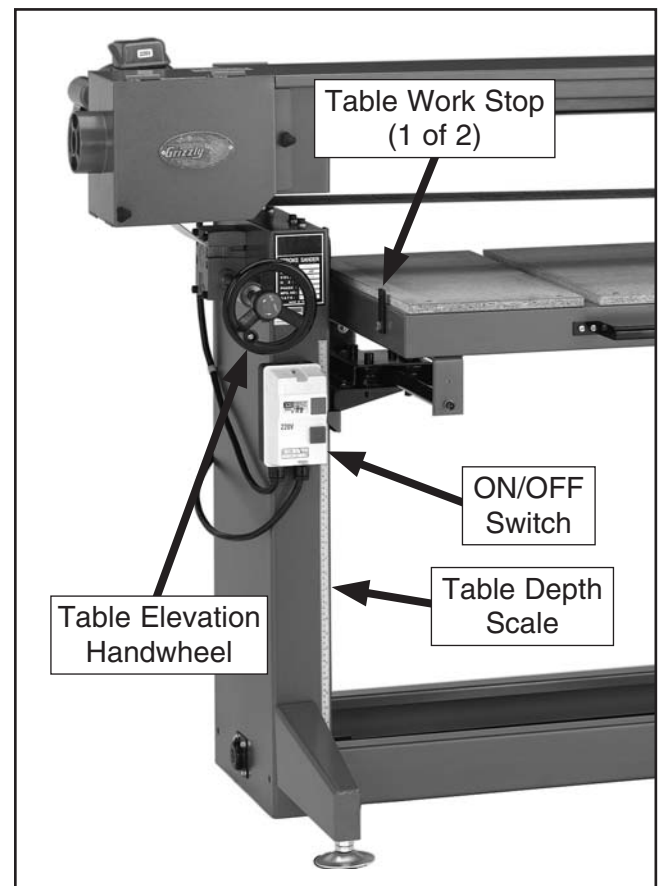
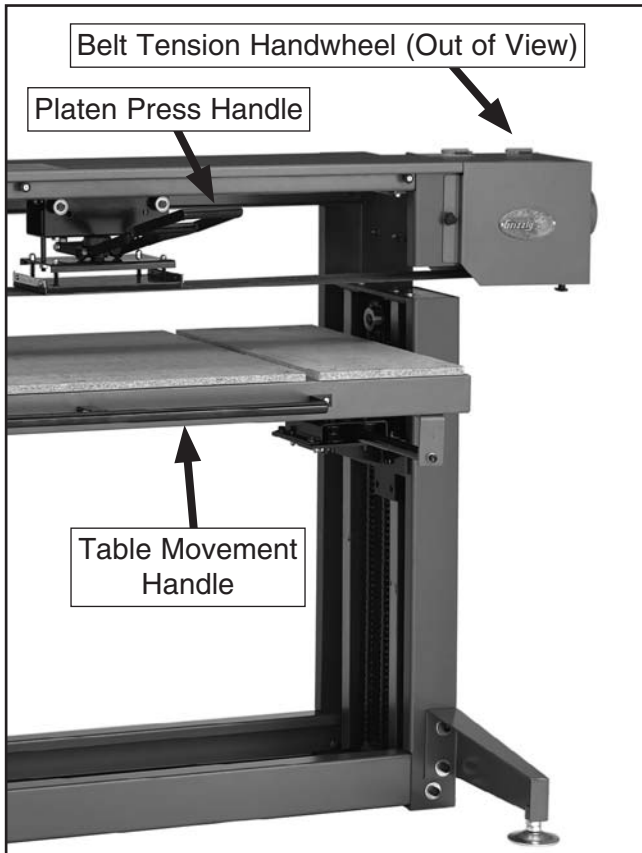

**Figure 31.** Basic controls.

**Belt Tension Handwheel:** Adjusts the amount of tension that is placed on the sanding belt.

**Platen Press Handle:** Used to exert platen pressure through the sanding belt and against the workpiece. Slides along the length of the table to allow complete sanding coverage.

**Table Movement Handle:** Allows for easy and safe movement of the table forward and backward to provide complete sanding coverage.



**Figure 32.** Basic controls (continued).

## Table Movement

The table on the Model G5394 can be moved both vertically and horizontally.

Vertical movement is used to accommodate workpieces of different thicknesses, and once set for a specific workpiece, doesn't need to be changed.

### To move the table vertically:

1. Place the workpiece on the table.
2. Turn the table elevation handwheel to raise the table until the workpiece is  $\frac{1}{4}$ "– $\frac{1}{2}$ " below the sanding belt (**Figure 33**).

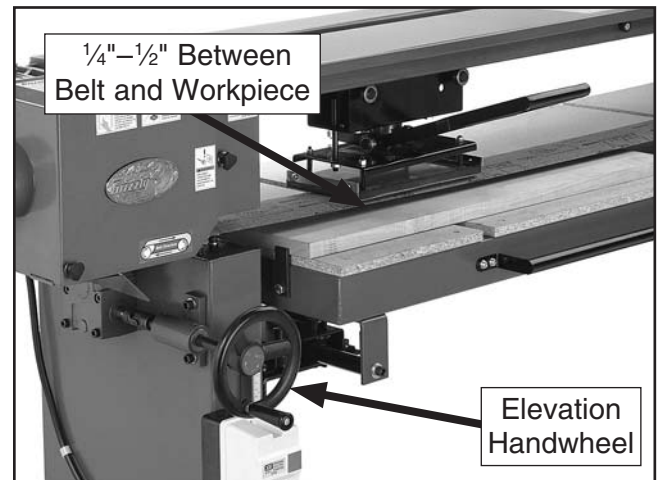

**Figure 33.** Vertical table movement.

**Note:** Due to the locking nature of the worm-drive gearbox, no lock is needed to prevent vertical table movement.

Horizontal table movement is used together with the platen press movement to allow complete sanding of workpieces with large surface areas.

### To move the table horizontally:

1. Push or pull the table handle to move the table forward and backward.



# Workstops

The Model G5394 is equipped with table workstops that prevent the workpiece from sliding off the table when sanding pressure is applied.

## **⚠️ WARNING**

The belt speed on the Model G5394 is 3500 FPM, or nearly 40 MPH. A workpiece ejected at this speed could cause serious personal injury and property damage. Always use the workstops and be sure they are in the correct position and secured before using the machine.

### To position the workstops:

1. Loosen the flange bolts that hold the workstops to the table (**Figure 34**).
2. Rotate the workstops so they protrude above the surface of the table, then re-tighten the flange bolts.

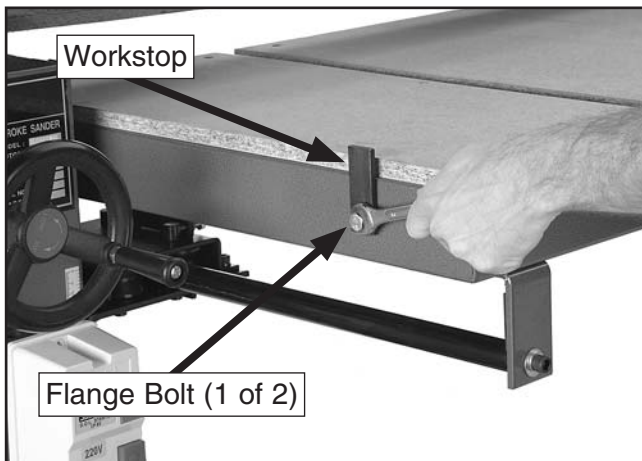

**Figure 34.** Table workstop.

# Platen Press

The platen press handle on the Model G5394 can be rotated and locked in position depending on your sanding needs and personal preferences.

### To rotate the platen press handle:

1. Loosen the lock knob shown in **Figure 35**.

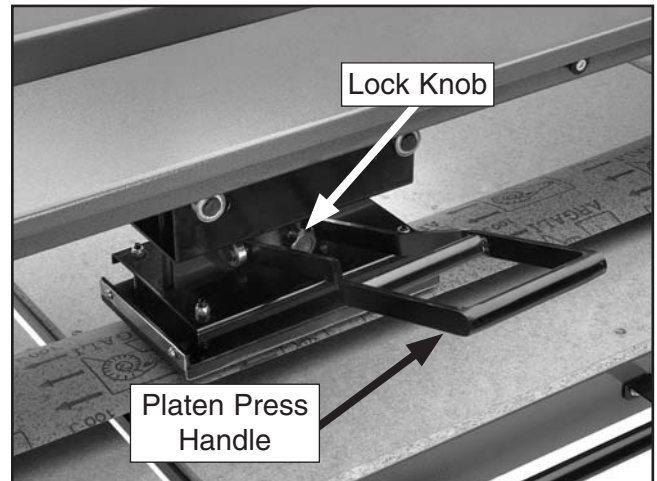

**Figure 35.** Platen press.

2. Rotate the handle as needed.
3. When the desired position is achieved, tighten the lock knob to secure the handle in its current position.

# Sanding Belt Replacement

Replacing the sanding belt on the Model G5394 is a simple process and must be performed when the sanding belt becomes worn or when a sanding belt of a different grit is desired.

## To replace the sanding belt:

1. DISCONNECT SANDER FROM POWER!
2. Use the belt tension knob to release tension from the belt.
3. Open the belt cover, drive wheel cover, and idler wheel cover (**Figure 36**).

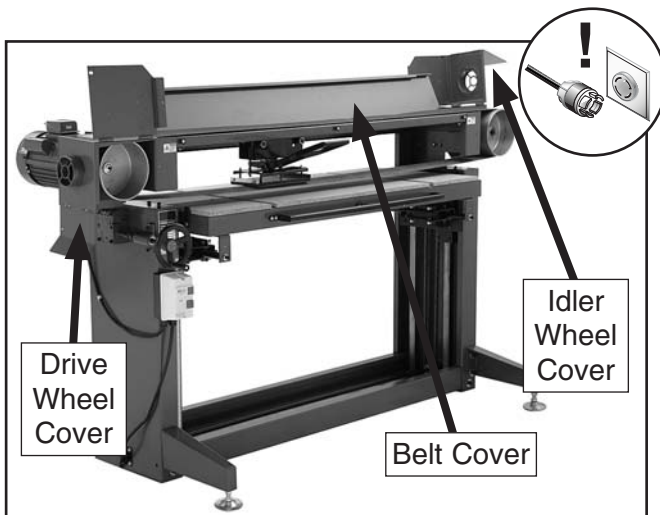

**Figure 36.** Belt covers open.

4. Slide the belt off of one of the wheels first, then remove the belt entirely.
5. Place the new sanding belt over one of the wheels, making sure the arrows printed on the back of the belt match the belt direction as indicated by the labels on the machine (the lower loop of the belt moves from right to left).

6. Place the belt along the top platen, under the platen press, and over the other wheel, as shown in **Figure 37**.



**Figure 37.** Installing new belt.

7. Center the belt over both wheels, then close the drive wheel and idler wheel covers.
8. Tension the belt so that the belt sags less than 1/2" across its length, then check the belt tracking, as described in **Belt Tracking** on **Page 32**.

# Platen Press Movement

A stroke sander is unique in that it uses a movable platen to apply sanding pressure to the workpiece. This allows the operator to vary the amount of material removed over different areas of the workpiece.

The platen press moves in two different planes. Movement in the vertical plane allows for variations in the amount of pressure applied while movement in the horizontal plane allows the user to sand different areas of the workpiece. This horizontal movement, combined with the horizontal movement of the table allows the entire surface of large workpieces to be sanded (**Figure 38**).

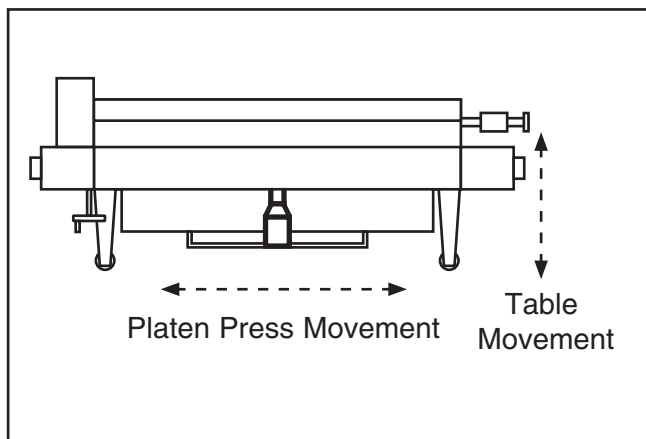

**Figure 38.** Sanding movements.

## To move the platen press:

1. Pull the platen press handle down to apply pressure to the workpiece.
2. Slide the platen press handle side-to-side to move the platen press along the length of the workpiece.

## To move the table:

1. Grasp the table handle.
2. Slide the table horizontally to move the workpiece across the width of the sanding-belt.

# Basic Operations

## To perform sanding operations:

1. Place the workpiece on the table and against the table workstops.
2. Make sure the workstops are secure and that they will not move during operation.
3. Tension the sanding belt.
4. Raise the table until the workpiece is approximately  $\frac{1}{4}$ "– $\frac{1}{2}$ " below the surface of the sanding belt.
5. Turn the machine **ON**.
6. Grasp the platen press handle and pull it downward to apply sanding pressure to the workpiece. Move the platen press along the length of the workpiece. If your workpiece is wider than the width of the belt, use the table handle to move the table horizontally to sand across the width of the workpiece.

**Note:** The proper amount of pressure to apply is dependent on a number of factors, including the grit of sandpaper being used, the type and moisture content of the wood being used, and the condition of the sandpaper. Knowing how much pressure to apply will take practice.

7. When the sanding is completed, turn the machine **OFF**.



# SECTION 5: ACCESSORIES

- T20501—Face Shield Crown Protector 4"
- T20502—Face Shield Crown Protector 7"
- T20503—Face Shield Window
- T20448—Economy Clear Safety Glasses
- T20452—"Kirova" Anti-Reflective Glasses
- T20456—"Dakura" Clear Safety Glasses
- H0736—Shop Fox® Safety Glasses

These glasses meet ANSI Z87.1-2003 specifications. Buy extras for visitors or employees. You can't be too careful with shop safety!



Figure 39. Our most popular eye protection.

- G5443—6" x 186"; 60 Grit
- G5444—6" x 186"; 80 Grit
- G5445—6" x 186"; 100 Grit
- G5446—6" x 186"; 120 Grit
- G5447—6" x 186"; 150 Grit
- G5548—6" x 186"; 180 Grit
- G5549—6" x 186"; 220 Grit

These high quality "J" weight cloth-backed belts last longer and sand smoother!

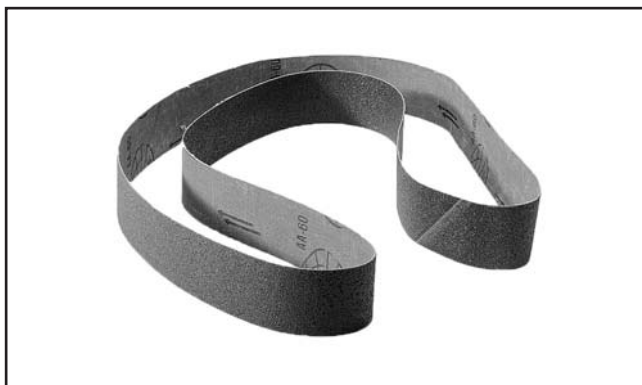

Figure 22. Replacement sanding belts.

## PRO-STICK® Abrasive Surface Cleaners

Extend the life of your sanding discs and sleeves! Choose the Pro-Stick® with a handle for greater control or without a handle for more usable area.

Size	Model
1½" X 1½" X 8½"	G1511
2" X 2" X 12"	G1512
1½" X 1½" X 9" with Handle	G2519
2" X 2" X 11" with Handle	G2520



Figure 40. PRO-STICK® abrasive cleaners.

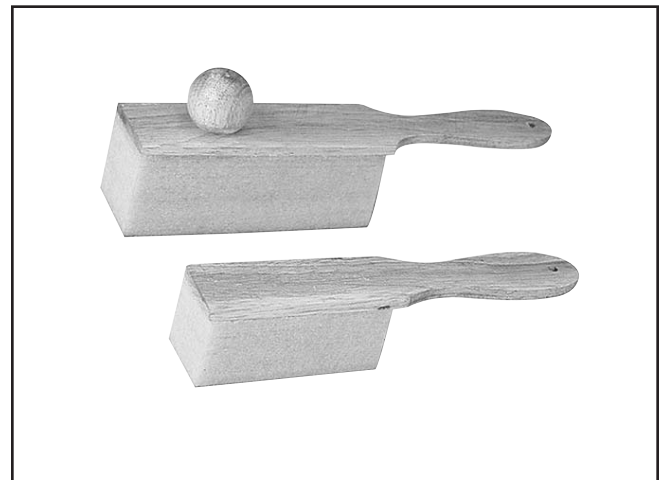

Figure 41. PRO-STICK® cleaners with handles.

**Call 1-800-523-4777 To Order**



**T20514—Small Half-Mask Respirator**  
**T20515—Medium Half-Mask Respirator**  
**T20516—Large Half-Mask Respirator**  
**T20511—Pre-Filter P100**  
**T20539—Cartridge Filter 2PK P100**  
**T20541—Cartridge Filter 2PK P100 & O Vapor**  
 Wood and other types of dust can cause severe respiratory damage. If you work around dust everyday, a half-mask respirator can greatly reduce your risk. Compatible with safety glasses!



**Figure 42.** Half-mask respirator with disposable cartridge filters.

**H2443—Universal Adapter**

This seven step adapter provides a multitude of dust collection reducing options. Simply cut away unneeded steps with a hacksaw. Outside diameter step sizes include 1", 2", 2.5", 3", 4", 5", and 6". Wall thickness is 1/8".

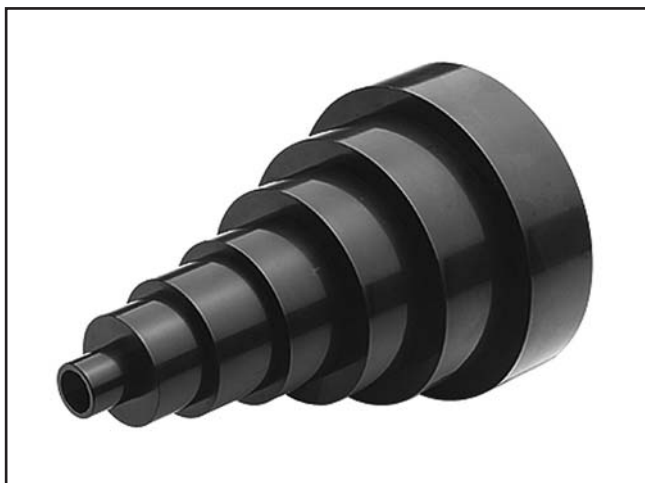

**Figure 43.** H2443 Universal Adapter.

**G2752—4" Rolling Floor Sweep**  
**G2753—4" Bench Dust Collection Attachment**  
**G2754—4" Floor Dust Collection Attachment**  
 These attachments are indispensable for collecting excess dust. The rolling floor sweep is also a convenient way to keep the shop floor or workbench top clean! Designed for use with 4" flexible hose (not included).

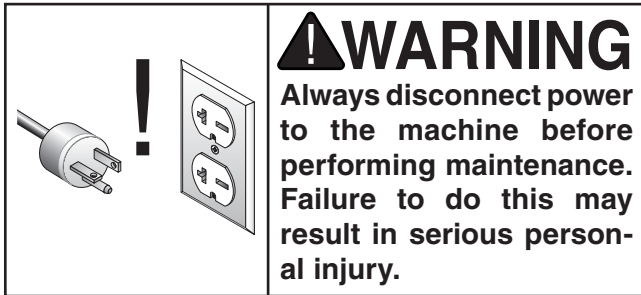

**Figure 44.** Dust collection attachments.

**Call 1-800-523-4777 To Order**



# SECTION 6: MAINTENANCE



## Schedule

For optimum performance from your machine, follow this maintenance schedule and refer to any specific instructions given in this section.

### Daily Check:

- Loose mounting bolts.
- Worn or damaged sanding belt.
- Worn or damaged wires.
- Any other unsafe condition.

### Weekly Maintenance:

- Grease table elevation ways.
- Oil table elevation chain.
- Clean/grease hold down shaft.

### Every 500 Hours:

- Refill table elevation gearbox oil.

## Cleaning

Cleaning the Model G5394 is relatively easy. Vacuum sawdust, and wipe off the remaining dust with a dry cloth. If any resin has built up, use a resin dissolving cleaner to remove it.

Use PRO-STICK® Abrasive Surface Cleaners to keep the sanding belt free from dust buildup. See **Accessories** on **Page 26** for more information.

## Lubrication

Lubrication for the Model G5394 consists of greasing the table elevation ways, oiling the table elevation chain, and refilling the table elevation gearbox.

### Table Elevation Ways

Clean the table elevation ways with mineral spirits and a rag or brush to remove any grime. Dry the ways, then brush on a thin coat of light multi-purpose grease. Use the table elevation handwheel to move the table up and down several times to disperse the grease (**Figure 45**).

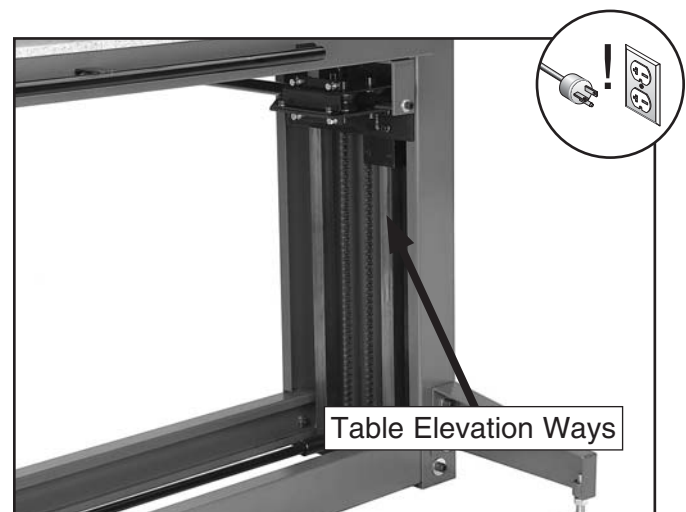

**Figure 45.** Table elevation ways.

## Table Elevation Chain

Clean the table elevation chain with mineral spirits and a rag or brush to remove any grime. To ensure complete cleaning of the chain, raise and lower the table to expose the entire length of chain. Dry the chain, then spray on a chain lubricant. Raise and lower the table several times to disperse the lubricant (**Figure 46**).

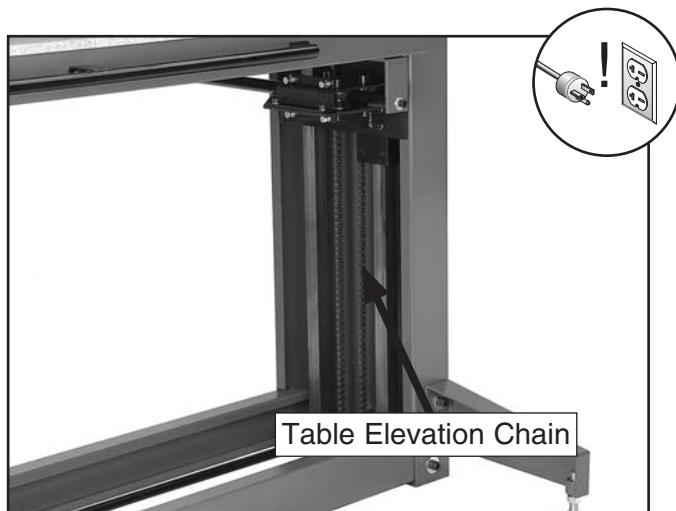

**Figure 46.** Table elevation chain.

## Table Elevation Gearbox

After every 500 hours of use, the table elevation gearbox must be refilled. Use a rag to clean any grime from around the filler plug, then remove the filler plug and use a manual oiler to add SAE 30 or equivalent oil until the gearbox is full. Replace the filler plug (**Figure 47**).

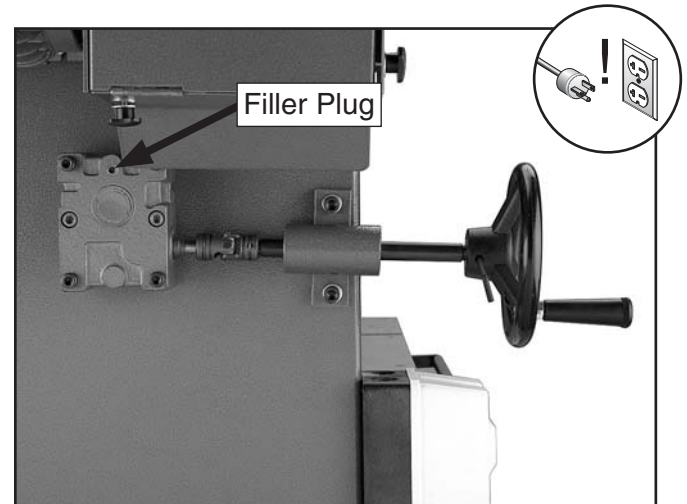
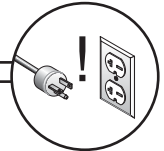

**Figure 47.** Table elevation gearbox.

# SECTION 7: SERVICE

Review the troubleshooting and procedures in this section to fix or adjust your machine if a problem develops. If you need replacement parts or you are unsure of your repair skills, then feel free to call our Technical Support at (570) 546-9663.

## Troubleshooting



### Motor & Electrical

Symptom	Possible Cause	Possible Solution
Machine does not start or a breaker trips.	<ol style="list-style-type: none"> <li>1. Power supply switched <b>OFF</b> or is at fault.</li> <li>2. Start capacitor is at fault.</li> <li>3. Motor connection wired incorrectly.</li> <li>4. Wall fuse/circuit breaker is blown/tripped.</li> <li>5. Wiring is open/has high resistance.</li> <li>6. Motor ON/OFF switch is at fault.</li> </ol>	<ol style="list-style-type: none"> <li>1. Ensure power supply is switched <b>ON</b>; ensure power supply has the correct voltage.</li> <li>2. Test/replace if faulty.</li> <li>3. Correct motor wiring connections (<b>Page 35</b>).</li> <li>4. Ensure circuit size is suitable for this machine; replace weak breaker.</li> <li>5. Check for broken wires or disconnected/corroded connections, and repair/replace as necessary.</li> <li>6. Replace faulty ON/OFF switch.</li> </ol>
Machine stalls or is overloaded.	<ol style="list-style-type: none"> <li>1. Motor connection is wired incorrectly.</li> <li>2. Motor bearings are at fault.</li> <li>3. Motor has overheated.</li> <li>4. Motor is at fault.</li> </ol>	<ol style="list-style-type: none"> <li>1. Correct motor wiring connections (<b>Page 35</b>).</li> <li>2. Test by rotating shaft; rotational grinding/loose shaft requires bearing replacement.</li> <li>3. Clean off motor, let cool, and reduce workload.</li> <li>4. Test/repair/replace.</li> </ol>
Machine has vibration or noisy operation.	<ol style="list-style-type: none"> <li>1. Motor or component is loose.</li> <li>2. Motor mount loose/broken/incorrect.</li> <li>3. Motor fan is rubbing on fan cover.</li> <li>4. Motor bearings are at fault.</li> </ol>	<ol style="list-style-type: none"> <li>1. Inspect/replace stripped or damaged bolts/nuts, and re-tighten with thread locking fluid.</li> <li>2. Tighten/replace/adjust.</li> <li>3. Replace dented fan cover; replace loose/damaged fan.</li> <li>4. Test by rotating shaft; rotational grinding/loose shaft requires bearing replacement.</li> </ol>





## Operations

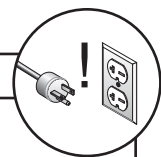

Symptom	Possible Cause	Possible Solution
Machine vibrates excessively (non-motor related).	<ol style="list-style-type: none"> <li>Stand not stable on floor.</li> <li>Incorrect sanding belt tension.</li> <li>Broken/defective sanding belt.</li> </ol>	<ol style="list-style-type: none"> <li>Level machine.</li> <li>Make sure tension is correct (<b>Page 24</b>).</li> <li>Replace sanding belt (<b>Page 24</b>).</li> </ol>
Deep sanding grooves or scores in workpiece.	<ol style="list-style-type: none"> <li>Sanding belt too coarse for the desired finish.</li> <li>Workpiece sanded across the grain.</li> <li>Too much sanding force on workpiece.</li> <li>Workpiece held still against the belt.</li> </ol>	<ol style="list-style-type: none"> <li>Use a finer grit sanding belt.</li> <li>Sand with the grain.</li> <li>Reduce pressure on workpiece while sanding.</li> <li>Keep the platen/workpiece moving while sanding on the belt.</li> </ol>
Abrasive grit rubs off the belt easily.	<ol style="list-style-type: none"> <li>Sanding belt has been stored in an incorrect environment.</li> <li>Sanding belt has been folded or smashed.</li> </ol>	<ol style="list-style-type: none"> <li>Store sanding belt away from extremely dry/hot or damp/wet temperatures.</li> <li>Store sanding belt flat, not folded or bent.</li> </ol>
Sanding belt surface clogs quickly or burns.	<ol style="list-style-type: none"> <li>Too much pressure applied to workpiece.</li> <li>Sanding softwood, paint, or other finishes.</li> <li>Sanding belt grit too fine.</li> </ol>	<ol style="list-style-type: none"> <li>Reduce pressure on workpiece while sanding.</li> <li>Use different stock. Or, accept the characteristics of the stock and plan on cleaning/replacing belts frequently.</li> <li>Use coarser grit sanding belt.</li> </ol>
Burn marks on workpiece.	<ol style="list-style-type: none"> <li>Using too fine of sanding grit.</li> <li>Using too much pressure.</li> <li>Platen press/workpiece held still for too long.</li> </ol>	<ol style="list-style-type: none"> <li>Use a coarser grit sanding belt.</li> <li>Reduce pressure on workpiece while sanding.</li> <li>Do not keep platen press/workpiece in one place for too long.</li> </ol>
Glazed sanding surfaces.	<ol style="list-style-type: none"> <li>Sanding wet stock.</li> <li>Sanding stock with high residue.</li> <li>Sandpaper is too fine.</li> </ol>	<ol style="list-style-type: none"> <li>Dry stock properly before sanding.</li> <li>Use different stock. Or, accept the characteristics of the stock and plan on cleaning/replacing belts frequently.</li> <li>Use a more coarse sandpaper.</li> </ol>
Belt rubs on machine frame.	<ol style="list-style-type: none"> <li>Tracking incorrect.</li> </ol>	<ol style="list-style-type: none"> <li>Adjust belt tracking (<b>Page 32</b>).</li> </ol>



# Table Bearings

The table rolls forward and backwards on bearing assemblies. If you notice excessive vertical or side-to-side play in the table, you may need to adjust the bearing assemblies.

The table rods roll between notched bearing wheels. By adjusting the lateral positioning of these wheels, play can be eliminated.

Tools Needed	Qty
Wrench 1/2".....	1

### To adjust the bearing assemblies:

1. Loosen the jam nuts on the bearing adjustment bolts (**Figure 48**).

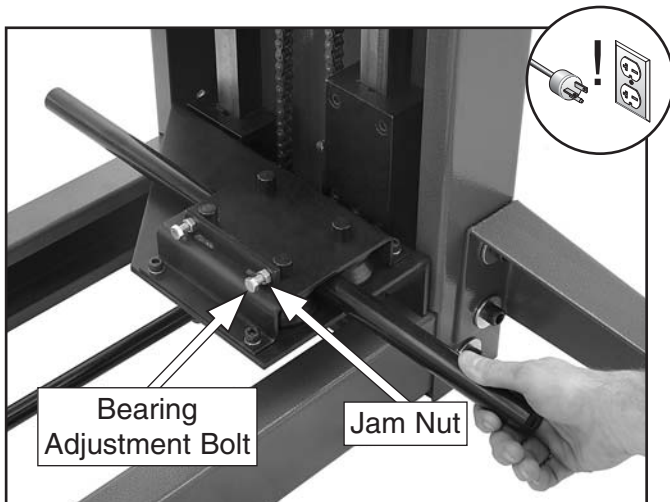

**Figure 48.** Table bearing adjustment (table removed for clarity).

2. Turn both adjustment bolts evenly until no play exists and the table still moves easily.
3. Without rotating the adjustment bolts, tighten the jam nuts.
4. Repeat **Steps 1–3** on the other side of the table.

# Belt Tracking

The sanding belt tracking on the Model G5394 can be adjusted to make sure the belt travels smoothly between the drive and idler wheels without rubbing on the sides of the platen assembly.

Tools Needed	Qty
Gloves .....	1 Pair
Hex Wrench 19mm.....	1
Wrench .....	1

### To adjust the sanding belt tracking:

1. Open the belt cover.
2. Loosen the jam nut on the belt tracking adjustment screw (**Figure 49**).

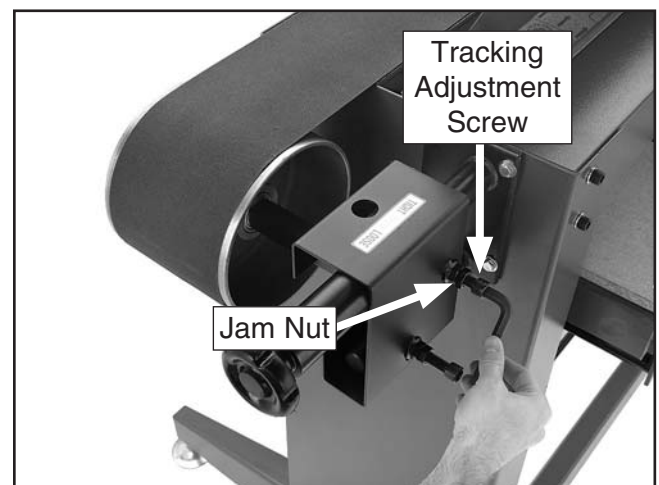

**Figure 49.** Belt tracking adjustment.

3. Spin the idler pulley by hand several times and observe the belt tracking.
4. Turn the tracking adjustment screw as needed until the belt is centered on the drive and idler wheels, then tighten the outer nut.
5. Spin the idler pulley by hand again to make sure the belt is still tracking properly. Start the machine and let it run to see if it continues tracking correctly.

—If the belt is tracking properly, no further adjustment is needed.

—If the belt is not tracking properly, repeat **Steps 4–5** until the tracking is correct.



# Table Elevation Wear Pin Adjustment

The table travels vertically along the table elevation ways. A series of wear pins reduce friction between the table brackets and elevation ways, making it easier to move the table up and down. Over time, these pins will wear, resulting in slop between the table brackets and elevation ways. To compensate for this wear, the wear pins can be adjusted.

Tools Needed	Qty
Wrench 14mm .....	1

## To adjust the wear pins:

1. DISCONNECT SANDER FROM POWER!
2. Loosen the jam nut shown in (Figure 50).

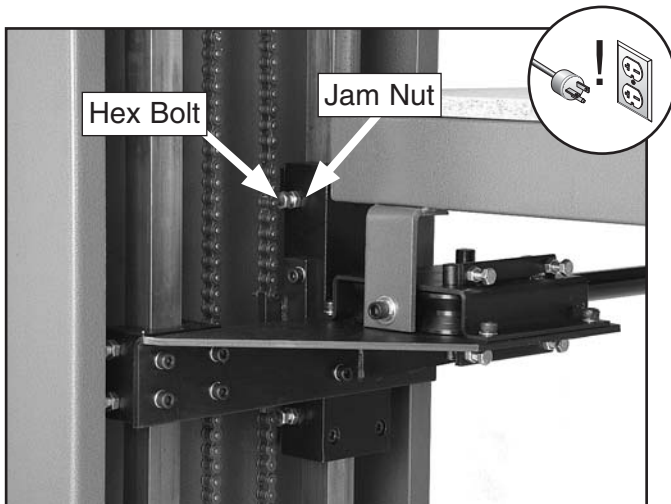

Figure 50. Wear pin adjustment.

3. Tighten the hex bolt until you just begin to feel resistance.  
—The goal is to position the wear pins against the ways without applying pressure to the them. The ideal setting will allow easy, slop-free vertical movement of the table.
4. When you are satisfied with the positioning of the hex bolt, keep it from turning and fully tighten the jam nut.
5. Repeat **Steps 2–4** for the remaining seven wear pins.



# SECTION 8: WIRING

These pages are current at the time of printing. However, in the spirit of improvement, we may make changes to the electrical systems of future machines. Study this section carefully. If there are differences between your machine and what is shown in this section, call Technical Support at (570) 546-9663 for assistance BEFORE making any changes to the wiring on your machine.

## WARNING















### Wiring Safety Instructions

- SHOCK HAZARD.** Working on wiring that is connected to a power source is extremely dangerous. Touching electrified parts will result in personal injury including but not limited to severe burns, electrocution, or death. Disconnect the power from the machine before servicing electrical components!
- QUALIFIED ELECTRICIAN.** Due to the inherent hazards of electricity, only a qualified electrician should perform wiring tasks on this machine. If you are not a qualified electrician, get help from one before attempting any kind of wiring job.
- WIRE CONNECTIONS.** All connections must be tight to prevent wires from loosening during machine operation. Double-check all wires disconnected or connected during any wiring task to ensure tight connections.
- MOTOR WIRING.** The motor wiring shown in these diagrams is current at the time of printing, but it may not match your machine. Always use the wiring diagram inside the motor junction box.
- WIRE/COMPONENT DAMAGE.** Damaged wires or components increase the risk of serious personal injury, fire, or machine damage. If you notice that any wires or components are damaged while performing a wiring task, replace those wires or components before completing the task.
- MODIFICATIONS.** Using aftermarket parts or modifying the wiring beyond what is shown in the diagram may lead to unpredictable results, including serious injury or fire.
- CAPACITORS.** Some capacitors store an electrical charge for up to five minutes after being disconnected from the power source. To avoid being shocked, wait at least this long before working on capacitors.
- CIRCUIT REQUIREMENTS.** You MUST follow the requirements on **Page 9** when connecting your machine to a power source.
- EXPERIENCING DIFFICULTIES.** If you are experiencing difficulties understanding the information included in this section, contact our Technical Support at (570) 546-9663.

#### NOTICE

The photos and diagrams included in this section are best viewed in color. You can view these pages in color at [www.grizzly.com](http://www.grizzly.com).

#### COLOR KEY

BLACK 	BLUE 	YELLOW 	LIGHT BLUE 
WHITE 	BROWN 	YELLOW GREEN 	BLUE WHITE 
GREEN 	GRAY 	PURPLE 	TURQUOISE 
RED 	ORANGE 	PINK 	



# Wiring Diagram



View this page in color at [www.grizzly.com](http://www.grizzly.com).

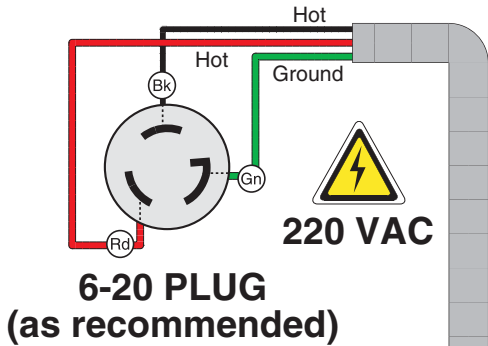

**220V MOTOR**

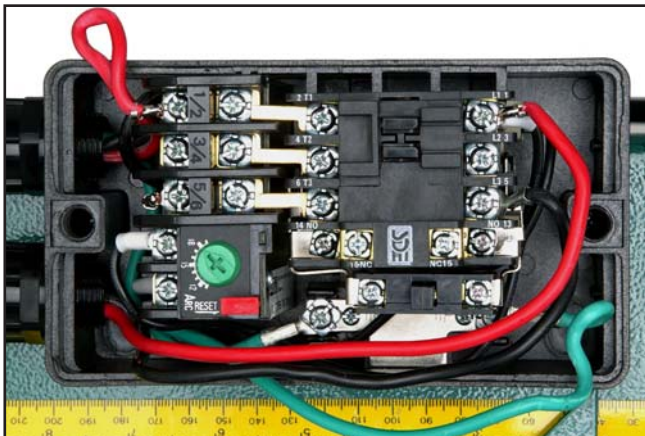
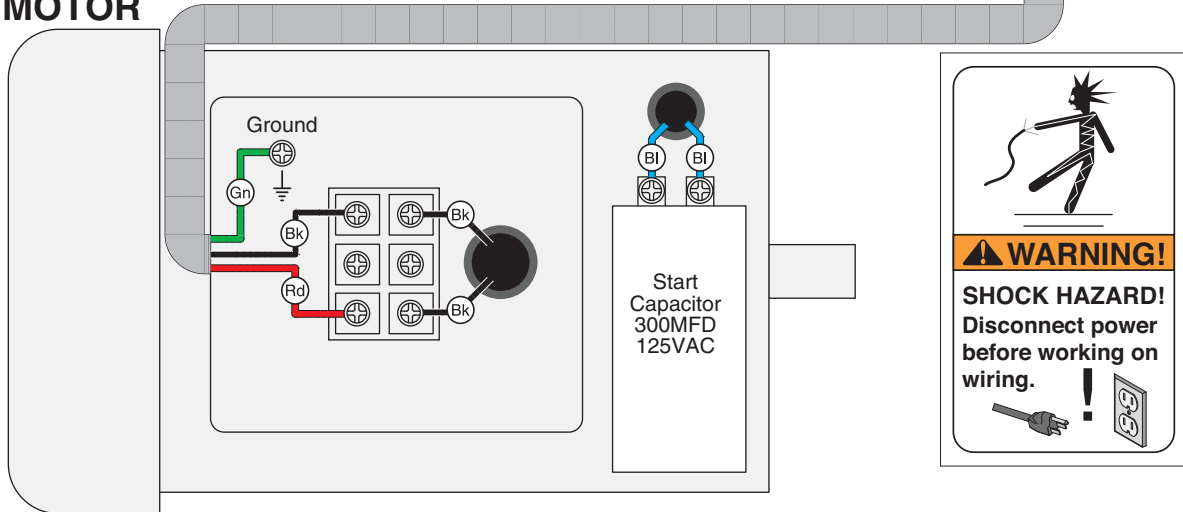

Figure 51. Switch wiring.

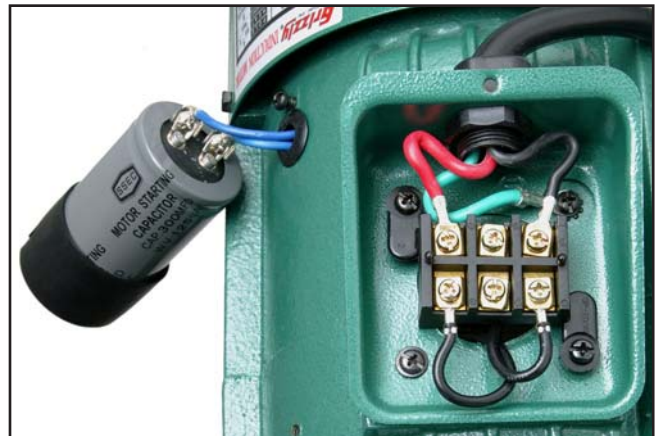

Figure 52. Motor wiring.





# SECTION 9: PARTS

## Main Breakdown

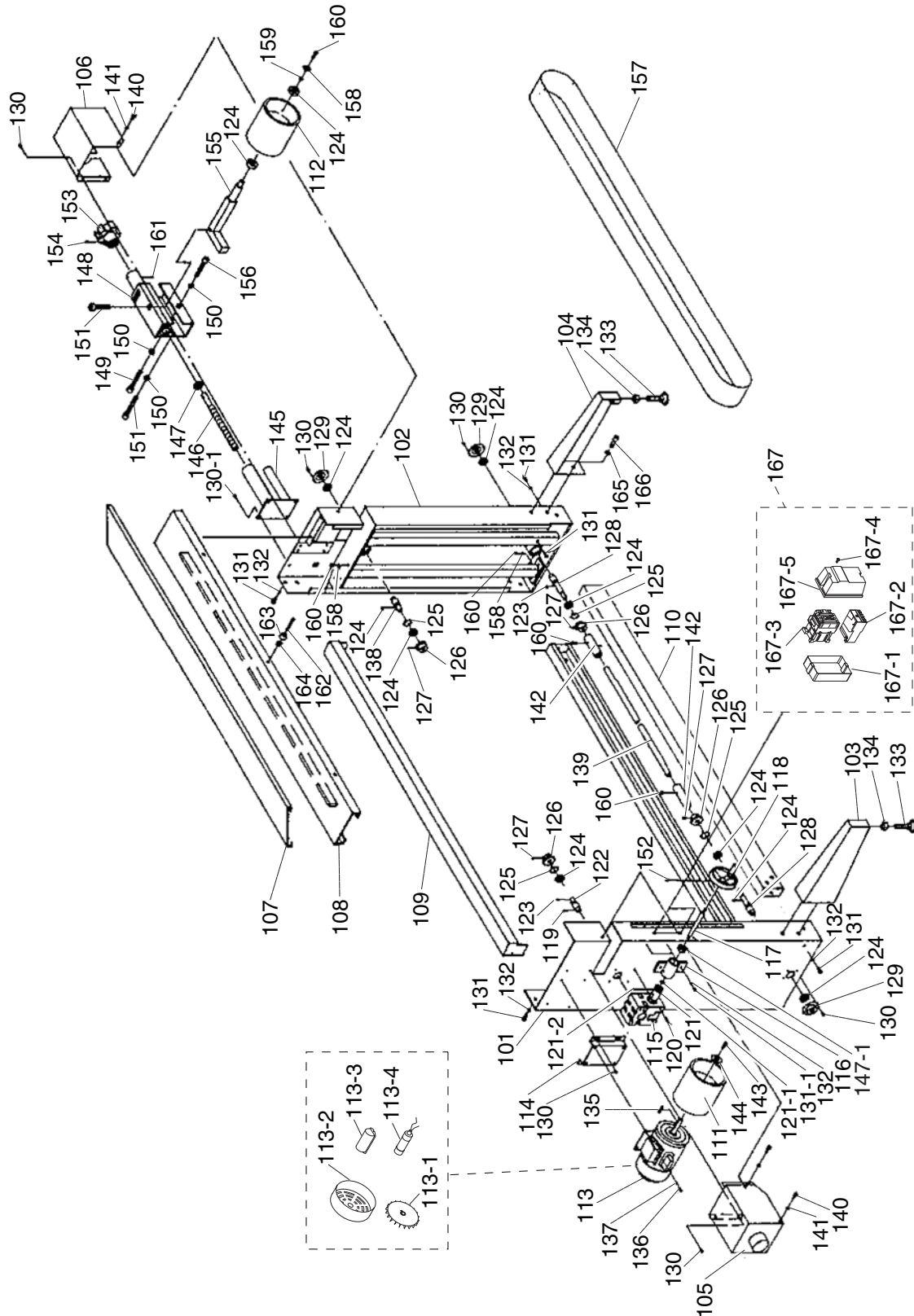

# Main Parts List

REF	PART #	DESCRIPTION
101	P5394101	LEFT FOOT
102	P5394102	RIGHT FOOT
103	P5394103	LEFT AUXILIARY FOOT
104	P5394104	RIGHT AUXILIARY FOOT
105	P5394105	LEFT PROTECTION COVER
106	P5394106	RIGHT PROTECTION COVER
107	P5394107	SANDER TABLE PROTECTION COVER
108	P5394108	SANDER TABLE
109	P5394109	TOP BEAM
110	P5394110	BOTTOM BEAM
111	P5394111	DRIVING WHEEL
112	P5394112	FOLLOWING WHEEL
113	P5394113	MOTOR 3HP 220V 1PH
113-1	P5394113-1	MOTOR FAN
113-2	P5394113-2	MOTOR FAN COVER
113-3	P5394113-3	CAPACITOR COVER
113-4	PC300F	S CAPACITOR 300M 125V 1-7/8 X 3-3/8
114	P5394114	MOTOR SEAT
115	P5394115	GEAR BOX
116	P5394116	SLEEVE BEARING MOUNT
117	P5394117	HAND WHEEL SPINDLE
118	P5394118	HANDWHEEL
119	P5394119	PIN
120	PSB148M	CAP SCREW M8-1.25 X 80
121	P5394121	UNIVERSAL JOINT
121-1	P5394121-1	FIXING RING OF UNIVERSAL JOINT
121-2	P5394121-2	FIXING PIN OF UNIVERSAL JOINT
122	P5394122	CHAIN WHEEL ADAPTER
123	PK157M	KEY 7 X 7 X 50
124	P6204	BALL BEARING 6204ZZ
125	PR09M	EXT RETAINING RING 20MM
126	P5394126	CHAIN WHEEL
127	PSS02	SET SCREW 5/16-18 X 3/8
128	P5394128	CHAIN WHEEL ADAPTER
129	P5394129	BALL BEARING MOUNT
130	PB09	HEX BOLT 5/16-18 X 1/2
130-1	PB03	HEX BOLT 5/16-18 X 1
131	PSB16	CAP SCREW 3/8-16 X 3/4
131-1	PSB14	CAP SCREW 3/8-16 X 1
132	PLN01	LOCK NUT 3/8-16
133	P5394133	FOOT CUSHION

REF	PART #	DESCRIPTION
134	PLN07	LOCK NUT 5/8-11
135	PK157M	KEY 7 X 7 X 50
136	PB03	HEX BOLT 5/16-18 X 1
137	PW07	FLAT WASHER 5/16
138	P5394138	CHAIN WHEEL ADAPTER
139	P5394139	CONNECTING ROD
140	P5394140	TRIANGULAR SCREW 1/4-20 X 1/2
141	PW06	FLAT WASHER 1/4
142	P5394142	SLEEVE COUPLING
143	P5394143	CAP SCREW M6-1 X 20 (LH)
144	PW03M	FLAT WASHER 6MM
145	P5394145	FOLLOWING WHEEL SUPPORT
146	P5394146	ADJUSTING SCREW 3/4-10
147	P5394147	SLEEVE BEARING 16 X 32 X 15.5
147-1	P5394147-1	SLEEVE BEARING 14 X 32 X 15.5
148	P5394148	ADJUSTING SUPPORT
149	P5394149	ADJUSTING SCREW 1/2-12 X 3
150	PLN06	LOCK NUT 1/2-13
151	P5394151	ADJUSTING SCREW 1/2-12 X 2
152	PSS02	SET SCREW 5/16-18 X 3/8
153	P5394153	HANDLE
154	PSS02	SET SCREW 5/16-18 X 3/8
155	P5394155	FOLLOWING WHEEL AXLE
156	P5394156	ADJUSTING SCREW 1/2-12 X 2
157	P5394157	SANDER BELT 6" X 186"
158	PLW01	LOCK WASHER 5/16
159	PW05M	FLAT WASHER 4MM
160	P5394160	CAP SCREW M6-1 X 20 (LH)
161	PSS07	SET SCREW 1/4-20 X 1/2
162	PB31	HEX BOLT 1/4-20 X 1
163	P5394163	PLASTIC CUSHION
164	PN05	HEX NUT 1/4"-20
165	PW01	FLAT WASHER 1/2
166	PSB72	CAP SCREW 1/2-13 X 1
167	P5394167	MAGNETIC SWITCH ASSEMBLY
167-1	P5394167-1	SWITCH CASE
167-2	P5394167-2	OL RELAY SDE RA-20
167-3	P5394167-3	CONTACTOR SDE MA-18
167-4	P5394167-4	PLASTIC COVER SCREW
167-5	P5394167-5	SWITCH COVER



# Table Assembly Breakdown

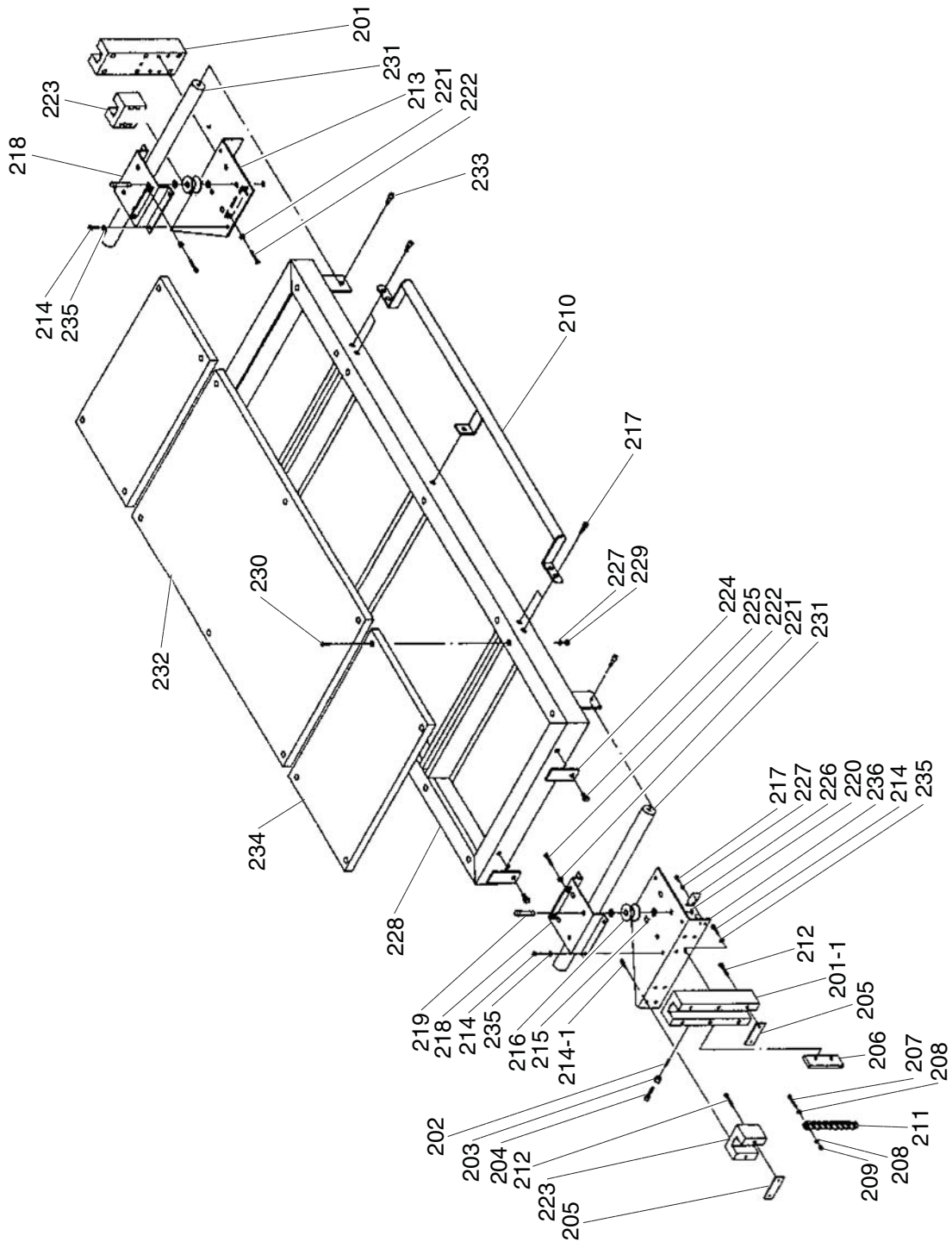



# Table Assembly Parts List

REF	PART #	DESCRIPTION
201	P5394201	TABLE BRACKET RIGHT
201-1	P5394201-1	TABLE BRACKET LEFT
202	P5394202	COPPER BAR 5/16" X 10MM
203	PN08	HEX NUT 3/8"-16
204	PB18	HEX BOLT 3/8-16 X 1
205	P5394205	PLATE
206	P5394206	KEY WHEEL FIXING PLATE
207	P5394207	SET SCREW 8-32 X 1
208	P5394208	LOCK WASHER #8
209	PN14	HEX NUT #8-32
210	P5394210	GRIP
211	P5394211	CHAIN
212	PSB70	CAP SCREW 5/16-18 X 2
213	P5394213	TABLE BASE RIGHT
214	PB07	HEX BOLT 5/16-18 X 3/4
214-1	PSB03	CAP SCREW 5/16-18 X 1
215	PW07	FLAT WASHER 5/16
216	P5394216	GUIDE ROLLER
217	PB51	HEX BOLT 1/4-20 X 3/8

REF	PART #	DESCRIPTION
218	P5394218	GUIDE ROLLER SEAT
219	P5394219	ARBOR
220	PR03M	EXT RETAINING RING 12MM
221	PN02	HEX NUT 5/16"-18
222	PB06	HEX BOLT 5/16-18 X 2
223	P5394223	AUXILIARY SLIDE
224	P5394224	FLAPPER
225	PB21	HEX BOLT 3/8-16 X 3/4
226	P5394226	SCALE POINTER
227	PW06	FLAT WASHER 1/4
228	P5394228	WORKTABLE
229	PN05	HEX NUT 1/4"-20
230	PFH16	FLAT HD SCR 1/4-20 X 1 1/4
231	P5394231	GUIDE BAR
232	P5394232	SYNTHETIC PLATE (LARGE)
233	PSB16	CAP SCREW 3/8-16 X 3/4
234	P5394234	SYNTHETIC PLATE (SMALL)
235	PLW01	LOCK WASHER 5/16
236	P5394236	TABLE BASE LEFT



# Platen Press Breakdown

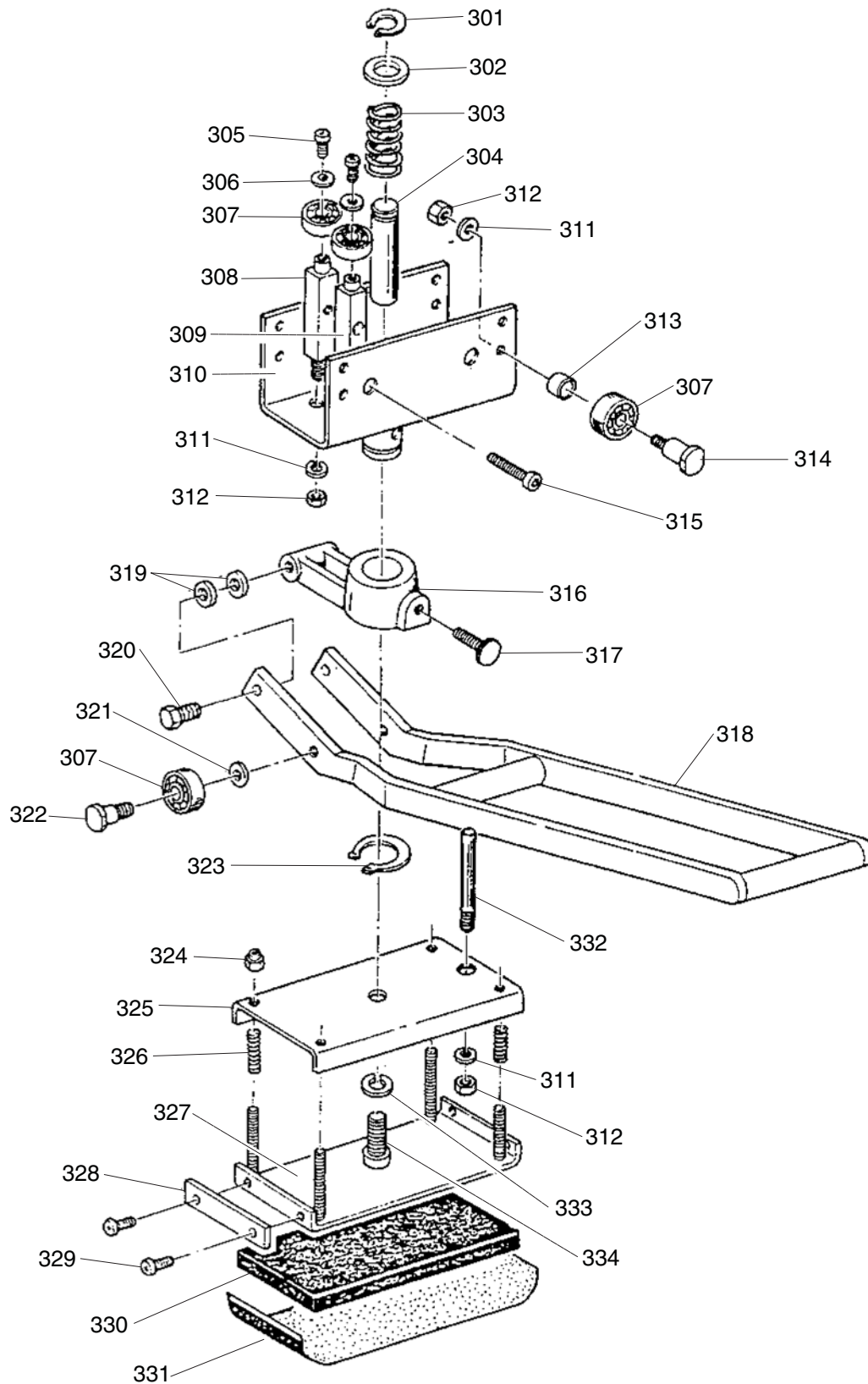

# Platen Press Parts List

REF	PART #	DESCRIPTION
301	PR11M	EXT RETAINING RING 25MM
302	PW19M	FLAT WASHER 25MM
303	P5394303	MIDDLE POST SPRING 3.2 X 35 X 82
304	P5394304	MIDDLE POST
305	PB51	HEX BOLT 1/4-20 X 3/8
306	PW06	FLAT WASHER 1/4
307	P6001	BALL BEARING 6001ZZ
308	P5394308	BACK BEARING PILLAR
309	P5394309	FRONT BEARING PILLAR
310	P5394310	UPPER PRESSING PLATE
311	PLW04	LOCK WASHER 3/8
312	PN08	HEX NUT 3/8"-16
313	P5394313	DISTANCE SLEEVE
314	P5394314	BEARING SHAFT
315	PSB159M	CAP SCREW 1/4-20 X 2
316	P5394316	PRESSING PLATE STAND
317	P5394317	OFFSET SCREW 5/16-18 X 3/4

REF	PART #	DESCRIPTION
318	P5394318	PRESSING PLATE HANDLE
319	P5394319	PLASTIC WASHER 8MM
320	PB07	HEX BOLT 5/16-18 X 3/4
321	PW02	FLAT WASHER 3/8
322	P5394322	BEARING SHAFT
323	PR31M	EXT RETAINING RING 38MM
324	PLN02	LOCK NUT 1/4-20
325	P5394325	MIDDLE PRESSING PLATE SEAT
326	P5394326	SPRING 1.3 X 9.6 X 42
327	P5394327	LOWER PRESSING PLATE SEAT
328	P5394328	FIXING PLATE
329	P5394329	FLANGE SCREW 10-24 X 3/8
330	P5394330	PAD
331	P5394331	GRAPHITE PAD
332	P5394332	GUIDE POST
333	PLW07	LOCK WASHER 1/2
334	P5394334	CAP SCREW 1/2-13 X 3/4



# Labels Breakdown & Parts List

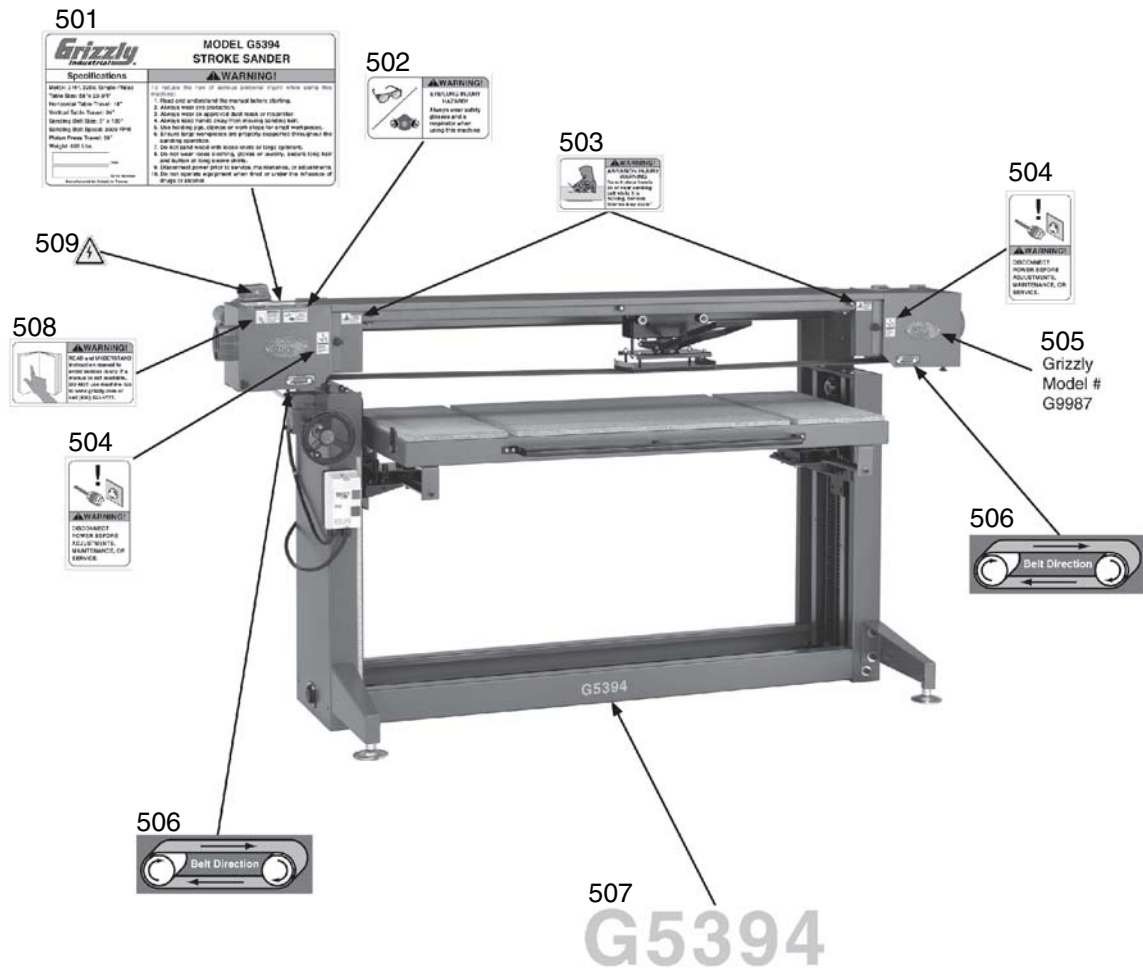

REF	PART #	DESCRIPTION
501	P5394501	MACHINE ID LABEL
502	PLABEL-57C	GLASSES/RESPIRATOR LABEL
503	P5394503	HAND ABRASION WARNING
504	PLABEL-63C	DISCONNECT WARNING
505	G9987	GRIZZLY NAMEPLATE

REF	PART #	DESCRIPTION
506	PLABEL-61C	BELT DIRECTION LABEL
507	P5394507	MODEL NUMBER LABEL
508	PLABEL-12D	READ MANUAL LABEL
509	PLABEL-14A	ELECTRICITY LABEL 0.7"

## ⚠️ WARNING

Safety labels warn about machine hazards and ways to prevent injury. The owner of this machine **MUST** maintain the original location and readability of the labels on the machine. If any label is removed or becomes unreadable, **REPLACE** that label before using the machine again. Contact Grizzly at (800) 523-4777 or [www.grizzly.com](http://www.grizzly.com) to order new labels.





# WARRANTY CARD

Name \_\_\_\_\_

Street \_\_\_\_\_

City \_\_\_\_\_ State \_\_\_\_\_ Zip \_\_\_\_\_

Phone # \_\_\_\_\_ Email \_\_\_\_\_ Invoice # \_\_\_\_\_

Model # \_\_\_\_\_ Order # \_\_\_\_\_ Serial # \_\_\_\_\_

The following information is given on a voluntary basis. It will be used for marketing purposes to help us develop better products and services. **Of course, all information is strictly confidential.**

1. How did you learn about us?

- Advertisement
- Card Deck
- Friend
- Website
- Catalog
- Other:

2. Which of the following magazines do you subscribe to?

- |   |  |   |
|---|--|---|
| <input type="checkbox"/> Cabinet Maker          | <input type="checkbox"/> Popular Mechanics   | <input type="checkbox"/> Today's Homeowner    |
| <input type="checkbox"/> Family Handyman        | <input type="checkbox"/> Popular Science     | <input type="checkbox"/> Wood                 |
| <input type="checkbox"/> Hand Loader            | <input type="checkbox"/> Popular Woodworking | <input type="checkbox"/> Wooden Boat          |
| <input type="checkbox"/> Handy                  | <input type="checkbox"/> Practical Homeowner | <input type="checkbox"/> Woodshop News        |
| <input type="checkbox"/> Home Shop Machinist    | <input type="checkbox"/> Precision Shooter   | <input type="checkbox"/> Woodsmith            |
| <input type="checkbox"/> Journal of Light Cont. | <input type="checkbox"/> Projects in Metal   | <input type="checkbox"/> Woodwork             |
| <input type="checkbox"/> Live Steam             | <input type="checkbox"/> RC Modeler          | <input type="checkbox"/> Woodworker West      |
| <input type="checkbox"/> Model Airplane News    | <input type="checkbox"/> Rifle               | <input type="checkbox"/> Woodworker's Journal |
| <input type="checkbox"/> Modeltec               | <input type="checkbox"/> Shop Notes          | <input type="checkbox"/> Other:               |
| <input type="checkbox"/> Old House Journal      | <input type="checkbox"/> Shotgun News        |   |

3. What is your annual household income?

- \$20,000-\$29,000
- \$30,000-\$39,000
- \$40,000-\$49,000
- \$50,000-\$59,000
- \$60,000-\$69,000
- \$70,000+

4. What is your age group?

- 20-29
- 30-39
- 40-49
- 50-59
- 60-69
- 70+

5. How long have you been a woodworker/metalworker?

- 0-2 Years
- 2-8 Years
- 8-20 Years
- 20+ Years

6. How many of your machines or tools are Grizzly?

- 0-2
- 3-5
- 6-9
- 10+

7. Do you think your machine represents a good value?  Yes  No

8. Would you recommend Grizzly Industrial to a friend?  Yes  No

9. Would you allow us to use your name as a reference for Grizzly customers in your area?  
**Note: We never use names more than 3 times.**  Yes  No

10. Comments: \_\_\_\_\_

---



---



---

CUT ALONG DOTTED LINE

FOLD ALONG DOTTED LINE

\_\_\_\_\_

\_\_\_\_\_

\_\_\_\_\_



Place  
Stamp  
Here



**GRIZZLY INDUSTRIAL, INC.**  
P.O. BOX 2069  
BELLINGHAM, WA 98227-2069



FOLD ALONG DOTTED LINE

Send a Grizzly Catalog to a friend:

Name _____
Street _____
City _____ State _____ Zip _____

TAPE ALONG EDGES--PLEASE DO NOT STAPLE



# WARRANTY AND RETURNS

---

Grizzly Industrial, Inc. warrants every product it sells for a period of **1 year** to the original purchaser from the date of purchase. This warranty does not apply to defects due directly or indirectly to misuse, abuse, negligence, accidents, repairs or alterations or lack of maintenance. This is Grizzly's sole written warranty and any and all warranties that may be implied by law, including any merchantability or fitness, for any particular purpose, are hereby limited to the duration of this written warranty. We do not warrant or represent that the merchandise complies with the provisions of any law or acts unless the manufacturer so warrants. In no event shall Grizzly's liability under this warranty exceed the purchase price paid for the product and any legal actions brought against Grizzly shall be tried in the State of Washington, County of Whatcom.

We shall in no event be liable for death, injuries to persons or property or for incidental, contingent, special, or consequential damages arising from the use of our products.

To take advantage of this warranty, contact us by mail or phone and give us all the details. We will then issue you a "Return Number," which must be clearly posted on the outside as well as the inside of the carton. We will not accept any item back without this number. Proof of purchase must accompany the merchandise.

The manufacturers reserve the right to change specifications at any time because they constantly strive to achieve better quality equipment. We make every effort to ensure that our products meet high quality and durability standards and we hope you never need to use this warranty.

Please feel free to write or call us if you have any questions about the machine or the manual.

Thank you again for your business and continued support. We hope to serve you again soon.

# *grizzly.com*

**TOOL WEBSITE**

Buy Direct and Save with Grizzly® – Trusted, Proven and a Great Value!

*Visit Our Website Today And Discover  
Why Grizzly® Is The Industry Leader!*

- SECURE ORDERING
- ORDERS SHIPPED WITHIN 24 HOURS
- E-MAIL RESPONSE WITHIN ONE HOUR

-OR-

Call Today For A **FREE**  
Full Color Catalog

**1-800-523-4777**



## Free Manuals Download Website

<http://myh66.com>

<http://usermanuals.us>

<http://www.somanuals.com>

<http://www.4manuals.cc>

<http://www.manual-lib.com>

<http://www.404manual.com>

<http://www.luxmanual.com>

<http://aubethermostatmanual.com>

Golf course search by state

<http://golfingnear.com>

Email search by domain

<http://emailbydomain.com>

Auto manuals search

<http://auto.somanuals.com>

TV manuals search

<http://tv.somanuals.com>