

Grizzly **Industrial, Inc.**®

COMBINATION SANDER **MODEL G1013** **INSTRUCTION MANUAL**



COPYRIGHT © 1991 BY GRIZZLY INDUSTRIAL, INC.

WARNING: NO PORTION OF THIS MANUAL MAY BE REPRODUCED IN ANY SHAPE OR FORM WITHOUT THE WRITTEN APPROVAL OF GRIZZLY INDUSTRIAL, INC.

REVISED FEBRUARY, 2002. PRINTED IN TAIWAN

ONLINE MANUAL DISCLAIMER

THE INFORMATION IN THIS MANUAL REPRESENTS THE CONFIGURATION OF THE MACHINE AS IT IS CURRENTLY BEING SHIPPED. THE MACHINE CONFIGURATION CAN CHANGE AS PRODUCT IMPROVEMENTS ARE INCORPORATED. IF YOU OWN AN EARLIER VERSION OF THE MACHINE, THIS MANUAL MAY NOT EXACTLY DEPICT YOUR MACHINE. CONTACT CUSTOMER SERVICE IF YOU HAVE ANY QUESTIONS ABOUT DIFFERENCES. PREVIOUS VERSIONS ARE NOT AVAILABLE ONLINE.

WARNING

Some dust created by power sanding, sawing, grinding, drilling, and other construction activities contains chemicals known to the State of California to cause cancer, birth defects or other reproductive harm. Some examples of these chemicals are:

- Lead from lead-based paints.
- Crystalline silica from bricks, cement, and other masonry products.
- Arsenic and chromium from chemically treated lumber.

Your risk from these exposures varies, depending on how often you do this type of work. To reduce your exposure to these chemicals: work in a well ventilated area, and work with approved safety equipment, such as those dust masks that are specially designed to filter out microscopic particles.

Table Of Contents

	PAGE
1. SAFETY	
SAFETY INSTRUCTIONS FOR POWER TOOLS	2-3
ADDITIONAL SAFETY INSTRUCTIONS FOR SANDERS	4
2. CIRCUIT REQUIREMENTS	
110V OPERATION	5
FUSING	5
EXTENSION CORDS	5
GROUNDING	5
3. INTRODUCTION	
COMMENTARY	6
UNPACKING.....	7
PARTS INVENTORY	8
CLEAN UP	9
SITE CONSIDERATIONS	9
4. ASSEMBLY	
OVERVIEW.....	10
ASSEMBLY PROCESS.....	10-13
5. ADJUSTMENTS	
BELT TRACKING	14
BELT TABLE TILT	15
BELT REPLACEMENT	15
DISC TABLE TILT	16
DISC REPLACEMENT	16
6. OPERATIONS	
TEST RUN	17
GENERAL SANDING	18
CONTOUR SANDING	18
INSIDE SANDING	19
SHARPENING	19
7. MAINTENANCE	
GENERAL.....	20
TABLE.....	20
LUBRICATION	20
MAINTENANCE NOTES	21
8. CLOSURE	22
MACHINE DATA	23
PARTS LIST AND DIAGRAM	24-25
WARRANTY AND RETURNS.....	26

SECTION 1: SAFETY

WARNING

For Your Own Safety Read Instruction Manual Before Operating This Equipment

The purpose of safety symbols is to attract your attention to possible hazardous conditions. This manual uses a series of symbols and signal words which are intended to convey the level of importance of the safety messages. The progression of symbols is described below. Remember that safety messages by themselves do not eliminate danger and are not a substitute for proper accident prevention measures.



Indicates an imminently hazardous situation which, if not avoided, WILL result in death or serious injury.



Indicates a potentially hazardous situation which, if not avoided, COULD result in death or serious injury.



Indicates a potentially hazardous situation which, if not avoided, MAY result in minor or moderate injury. It may also be used to alert against unsafe practices.

NOTICE

This symbol is used to alert the user to useful information about proper operation of the equipment.

WARNING

Safety Instructions For Power Tools

1. **KEEP GUARDS IN PLACE** and in working order.
2. **REMOVE ADJUSTING KEYS AND WRENCHES.** Form habit of checking to see that keys and adjusting wrenches are removed from tool before turning on.
3. **KEEP WORK AREA CLEAN.** Cluttered areas and benches invite accidents.
4. **NEVER USE IN DANGEROUS ENVIRONMENT.** Do not use power tools in damp or wet locations, or where any flammable or noxious fumes may exist. Keep work area well lighted.
5. **KEEP CHILDREN AND VISITORS AWAY.** All children and visitors should be kept a safe distance from work area.
6. **MAKE WORKSHOP CHILD PROOF** with padlocks, master switches, or by removing starter keys.
7. **NEVER FORCE TOOL.** It will do the job better and safer at the rate for which it was designed.
8. **USE RIGHT TOOL.** Do not force tool or attachment to do a job for which it was not designed.

WARNING

Safety Instructions For Power Tools

9. **USE PROPER EXTENSION CORD.** Make sure your extension cord is in good condition. Conductor size should be in accordance with the chart below. The amperage rating should be listed on the motor or tool nameplate. An undersized cord will cause a drop in line voltage resulting in loss of power and overheating. Your extension cord must also contain a ground wire and plug pin. Always repair or replace extension cords if they become damaged.

Minimum Gauge for Extension Cords

AMP RATING	LENGTH		
	25ft	50ft	100ft
0-6	18	16	16
7-10	18	16	14
11-12	16	16	14
13-16	14	12	12
17-20	12	12	10
21-30	10	10	No

10. **WEAR PROPER APPAREL.** Do not wear loose clothing, gloves, neckties, rings, bracelets, or other jewelry which may get caught in moving parts. Non-slip footwear is recommended. Wear protective hair covering to contain long hair.
11. **ALWAYS USE SAFETY GLASSES.** Also use face or dust mask if cutting operation is dusty. Everyday eyeglasses only have impact resistant lenses, they are NOT safety glasses.
12. **SECURE WORK.** Use clamps or a vise to hold work when practical. It's safer than using your hand and frees both hands to operate tool.
13. **NEVER OVERREACH.** Keep proper footing and balance at all times.
14. **MAINTAIN TOOLS WITH CARE.** Keep tools sharp and clean for best and safest performance. Follow instructions for lubricating and changing accessories.
15. **DISCONNECT TOOLS** before servicing and changing accessories, such as blades, bits, cutters, and the like.
16. **REDUCE THE RISK OF UNINTENTIONAL STARTING.** Make sure switch is in off position before plugging in.
17. **USE RECOMMENDED ACCESSORIES.** Consult the owner's manual for recommended accessories. The use of improper accessories may cause risk of injury.
18. **CHECK DAMAGED PARTS.** Before further use of the tool, a guard or other part that is damaged should be carefully checked to determine that it will operate properly and perform its intended function. Check for alignment of moving parts, binding of moving parts, breakage of parts, mounting, and any other conditions that may affect its operation. A guard or other part that is damaged should be properly repaired or replaced.
19. **NEVER LEAVE TOOL RUNNING UNATTENDED. TURN POWER OFF.** Do not leave tool until it comes to a complete stop.
20. **NEVER USE UNDER THE INFLUENCE** of alcohol or drugs, or when tired.
21. **NEVER ALLOW UNSUPERVISED OR UNTRAINED PERSONNEL TO OPERATE THE MACHINE.** Make sure any instructions you give in regards to the operation of the machine are approved, correct, safe, and clearly understood.

WARNING

Additional Safety Instructions For Sanders

1. **BE AWARE OF BELT** or disc rotation when sanding.
2. **KEEP FINGERTIPS AWAY** from the moving belt or disc. Serious injury could result if skin contacts abrasives or moving parts.
3. **NEVER USE EXCESSIVE FORCE** when sanding. Doing this greatly increases the chances of personal injury and motor overload.
4. **ALWAYS FEED THE WORK** against the direction of rotation.
5. **EVEN IF YOU HAVE A** reliable method of dust collection, use a dust mask or respirator when sanding, as well as eye and ear protection.
6. **IF THERE IS ANY** doubt as to the stability or integrity of the material to be sanded, **don't sand it.**
7. **DO NOT OPERATE SANDER** with a damaged or badly worn disc or belt.
8. **WHEN DISC SANDING**, feed material into the portion of the disc spinning *down* toward the table.
9. **TIE BACK LONG HAIR** and remove any loose-fitting clothing or jewelry that could be caught up in the sander's disc, belt, or other moving machine parts.
10. **HABITS — GOOD OR BAD** — are hard to break. Develop good habits and safety will become second nature to you.

WARNING

Like all power tools, there is danger associated with the Model G1013 Combination Sander. Accidents are frequently caused by lack of familiarity or failure to pay attention. Use this tool with respect and caution to lessen the possibility of operator injury. If normal safety precautions are overlooked or ignored, serious personal injury may occur.

CAUTION

No list of safety guidelines can be complete. Every shop environment is different. Always consider safety first, as it applies to your individual working conditions. Use this and other machinery with caution and respect. Failure to do so could result in serious personal injury, damage to equipment or poor work results.

WARNING

Operating this equipment has the potential to propel debris into the air which can cause eye injury. Always wear safety glasses or goggles when operating equipment. Everyday glasses or reading glasses only have impact resistant lenses, they are not safety glasses. Be certain the safety glasses you wear meet the appropriate standards of the American National Standards Institute (ANSI).

SECTION 2: CIRCUIT REQUIREMENTS

110V Operation

The Model G1013 is wired for 110V, single-phase operation only. The ½ H.P. motor will safely draw 12 amps at 110V. If you operate this sander on any circuit that is already close to its capacity, it might blow a fuse or trip a circuit breaker. However, if an unusual load does not exist and a power failure still occurs, contact a qualified electrician or our service department.



Fusing

A 15-amp fuse or circuit breaker should be used when fusing this combination sander. Circuit breakers rated any higher are not adequate to protect the circuit from power surges.



Extension Cords

If you find it necessary to use an extension cord with the Model G1013, make sure the cord is rated Hard Service (grade S) or better. Refer to the chart in the standard safety instructions to determine the minimum gauge for the extension cord. The extension cord must also contain a ground wire and plug pin. Always repair or replace extension cords when they become worn or damaged.



Grounding

In the event of an electrical short, grounding reduces the risk of electric shock by providing a path of least resistance to disperse electric current. This tool is equipped with a power cord having an equipment-grounding conductor. **See Figure 1.** The outlet must be properly installed and grounded in accordance with all local codes and ordinances.

⚠️ WARNING

This equipment must be grounded. Verify that any existing electrical outlet and circuit you intend to plug into is actually grounded. If it is not, it will be necessary to run a separate 12 A.W.G. copper grounding wire from the outlet to a known ground. Under no circumstances should the grounding pin from any three-pronged plug be removed. Serious injury may occur.

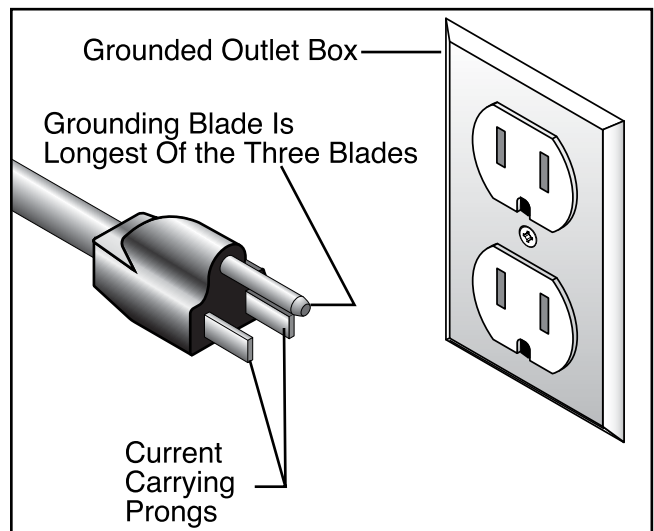

Figure 1. Grounded plug configuration.



SECTION 3: Introduction

Commentary

We are proud to offer the Grizzly Model G1013 Combination Sander. The Model G1013 is part of a growing Grizzly family of fine woodworking machinery. When used according to the guidelines set forth in this manual, you can expect years of trouble-free, enjoyable operation and proof of Grizzly's commitment to customer satisfaction.

The Model G1013 is a combination 1" x 42" belt and 8" disc sander that is capable of a wide variety of operations. The 1" wide belt enables you to sand small or finely-detailed pieces as well as the inside areas of closed loops. With the 8" disc and table, larger surfaces can be sanded at many different angles. The Model G1013 comes complete with motor and electrical package.

A number of sanding discs and belts for the Model G1013 are available through the Grizzly catalog.

We are also pleased to provide this manual with the Model G1013. It was written to guide you through assembly, review safety considerations, and cover general operating procedures. It represents our effort to produce the best documentation possible. If you have any comments regarding this manual, please write to us at the address below:

Grizzly Industrial, Inc.
c/o Technical Documentation
P.O. Box 2069
Bellingham, WA 98227-2069

Most importantly, we stand behind our machines. If you have any service questions or parts requests, please call or write us at the location listed below.

Grizzly Industrial, Inc.
1203 Lycoming Mall Circle
Muncy, PA 17756
Phone: (570) 326-3806
Fax: (800) 438-5901
E-Mail: techsupport@grizzlyindustrial.com
Web Site: <http://www.grizzlyindustrial.com>

The specifications, drawings, and photographs illustrated in this manual represent the Model G1013 as supplied when the manual was prepared. However, owing to Grizzly's policy of continuous improvement, changes may be made at any time with no obligation on the part of Grizzly. Whenever possible, though, we send manual updates to all owners of a particular tool or machine. Should you receive one, we urge you to insert the new information with the old and keep it for reference.

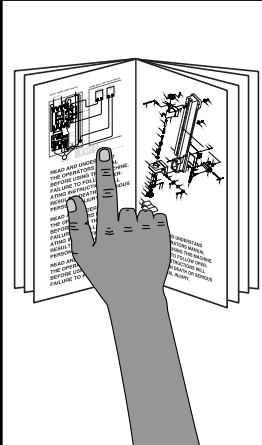
	<p>!WARNING</p> <p>Read the manual before assembly and operation. Become familiar with the machine and its operation before beginning any work. Serious personal injury may result if safety or operational information is not understood or followed.</p>
--	--



Parts Inventory

After all the parts have been removed from the carton, you should have:

- Belt Guard
- Disc Guard
- Disc Table
- Bolt Bag
- Table Support
- Sanding Unit
- Motor
- Miter Gauge
- Belt Table
- V-Belt
- Base
- Aluminum Disc
- Disc Sanding Paper
- Motor Pulley

Hardware	Qty
5/16" - 18 x 5/8" Carriage Bolts	5
5/16" - 18 x 3/4" Hex Bolts	4
5/16" - 18 Hex Nuts	13
5/16" Flat Washers	20
1/4" - 20 x 1 1/4" Hex Bolts	4
1/4" - 20 x 1" Hex Bolts	4
1/4" - 20 Nuts	4
1/4" Flat Washers	16
1/4" - 20 x 1 1/4" Carriage Bolts	2
1/4" - 20 Wing Nuts	2
M5-0.8 x 6mm Phillips® Head Screws	4
5mm Flat Washers	4
1/4" - 20 x 3/8" Setscrews	2
3/16" Sq. x 3/4" Keys	2
5/16" Fender Washer	1
Rubber Feet	4
Wire Nuts	2
3mm Allen® Wrench	1



NOTICE

A full parts list and breakdown drawing can be found toward the end of this manual. For easier assembly, or to identify missing parts, please refer to the detailed illustrations at the end of the manual.

Clean Up

The unpainted surfaces are coated with a waxy oil to protect them from corrosion during shipment. Remove this protective coating with a solvent cleaner or citrus-based degreaser. Avoid chlorine-based solvents as they may damage painted surfaces should they come in contact. Always follow the usage instructions on the product you choose for clean up.

	<p>! WARNING Do not use gasoline or other petroleum-based solvents to clean with. They have low flash points which make them extremely flammable. A risk of explosion and burning exists if these products are used. Serious personal injury may occur.</p>
---	--

	<p>! WARNING Do not smoke while using solvents. A risk of explosion or fire exists and may result in serious personal injury.</p>
---	--

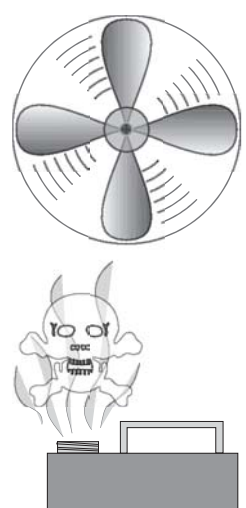
	<p>! CAUTION Many of the solvents commonly used to clean machinery can be toxic when inhaled or ingested. Always work in well-ventilated areas far from potential ignition sources when dealing with solvents. Use care when disposing of waste rags and towels to be sure they do not create fire or environmental hazards.</p>
---	---



Site Consideration

BENCH LOAD

Your Model G1013 Combination Sander represents a relatively large weight load in a small footprint. Be sure that your workbench is adequately reinforced to support the weight of the sander.

WORKING CLEARANCES

Working clearances can be thought of as the distances between machines and obstacles that allow safe operation of every machine without limitation. Ensure that your working area offers plenty of room for free movement and a substantial amount of distance between you and others that may be working in your shop area.

LIGHTING AND OUTLETS

Lighting should be bright enough to eliminate shadow and prevent eye strain. Electrical circuits should be dedicated or large enough to handle combined motor amp loads. Outlets should be located near each machine so power or extension cords are not obstructing high-traffic areas. Be sure to observe local electrical codes for proper installation of new lighting, outlets, or circuits.

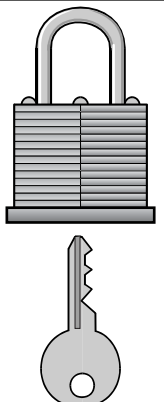
	<p>! CAUTION Make your shop "child safe." Ensure that your workplace is inaccessible to children by closing and locking all entrances when you are away. Never allow visitors in your shop when assembling, adjusting or operating equipment.</p>
--	--



SECTION 4: ASSEMBLY

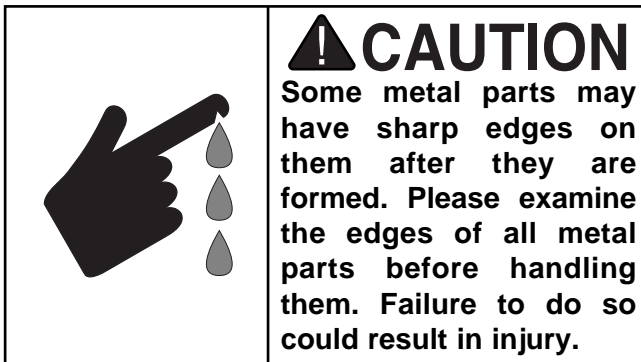
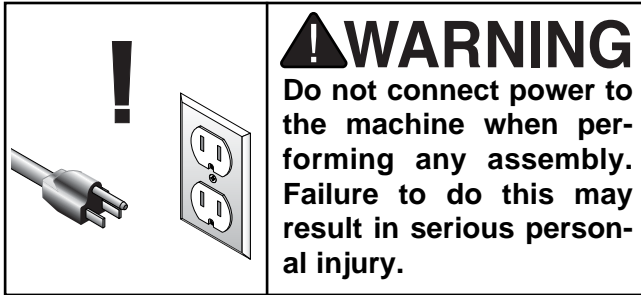

Overview

The majority of your Combination Sander has been assembled at the factory. The few remaining pieces will go together quickly and should be done in the following order:

1. Feet to Base
2. Sanding Unit to Base
3. Table Support to Base
4. Motor to Base
5. Motor Pulley to Motor Shaft
6. V-Belt to Pulleys
7. Belt Guards to Sanding Unit
8. Aluminum Disc to Motor Shaft
9. Tables to Sanding Unit
10. Wiring motor

Only a few common tools are required to assemble your Combination Sander. Specifically, these are: 6" adjustable wrench, 10mm open end wrench, 12mm open end wrench, Phillips® head screwdriver, 3mm Allen® wrench (supplied with machine), and a rubber mallet.



Assembly Process

Assemble as follows:

1. Attach the four (4) rubber feet to the base using the four (4) $\frac{1}{4}$ " - 20 x 1" hex bolts, four (4) $\frac{1}{4}$ " flat washers and four (4) $\frac{1}{4}$ " - 20 hex nuts. Be sure that the bolts protrude upward through the base. **See Figure 3.**

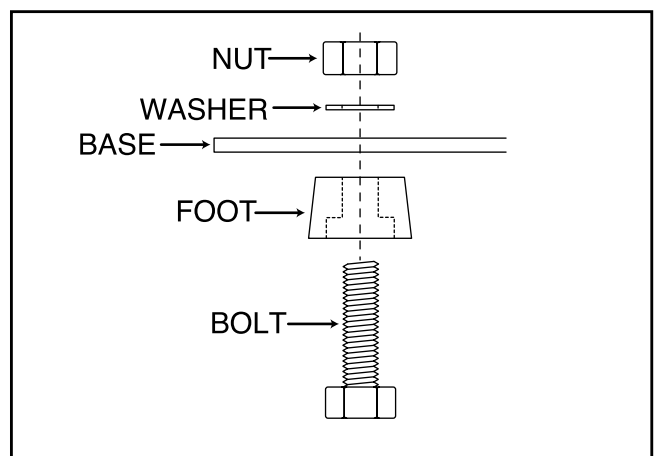

Figure 3. Order of foot attachment.

2. Place the preassembled Sanding Unit onto the Base as shown in **Figure 4.** Secure with the four (4) $\frac{5}{16}$ " - 18 x $\frac{3}{4}$ " hex bolts, eight (8) $\frac{5}{16}$ " flat washers, and four (4) $\frac{5}{16}$ " - 18 hex nuts.



Figure 4. Sanding unit mounted on base.

3. Attach the Disc Table Support to the base using the four (4) $\frac{5}{16}$ " - 18 x $1\frac{1}{4}$ " hex bolts, eight (8) $\frac{5}{16}$ " washers, and four (4) $\frac{5}{16}$ " - 18 hex nuts. **See Figure 5.** Finger tighten for now.

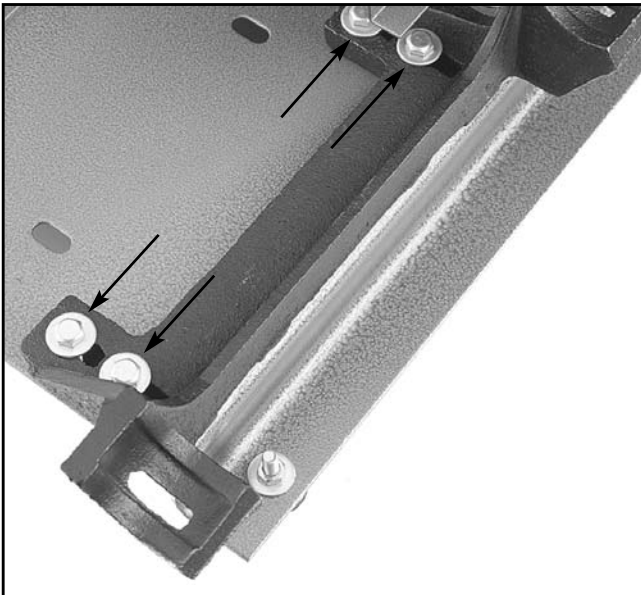

Figure 5. Table support mounted on base.

4. Mount the Motor to the base using the four (4) $\frac{5}{16}$ " - 18 x $\frac{5}{8}$ " carriage bolts, four (4) $\frac{5}{16}$ " washers, and four (4) $\frac{5}{16}$ " - 18 hex nuts. Be sure that the bolts protrude upward through the motor base. **See Figure 6.** Finger tighten only.

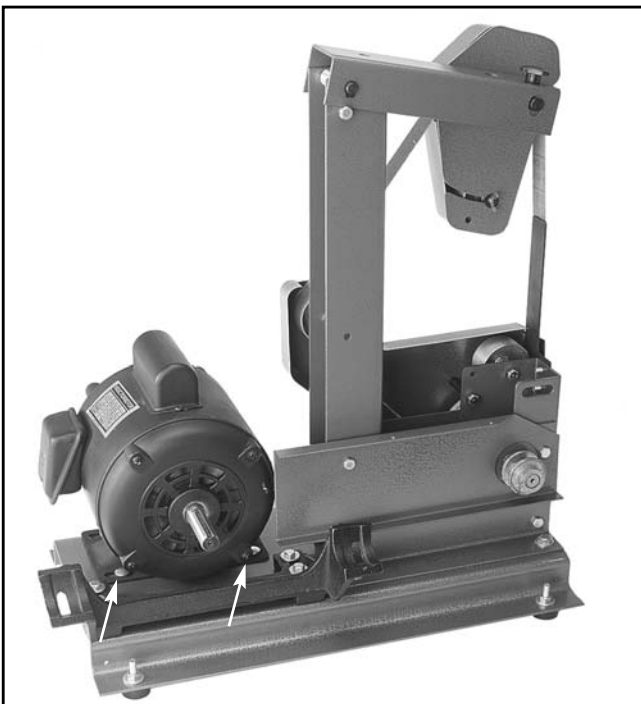

Figure 6. Motor mounted on base.

5. Install the Motor Pulley onto the Motor Shaft. Lightly tap into place with a rubber mallet if necessary. Align the keyways on each and insert the $\frac{3}{16}$ " square key. Secure with a $\frac{1}{4}$ " - 20 x $\frac{3}{8}$ " setscrew. **See Figure 7.**



Figure 7. Motor pulley attachment.

6. Place the V-Belt onto the pulleys.
7. Set a straightedge across the edge of both pulleys and adjust the position of the motor to correct the pulley alignment. The straight-edge should evenly touch each pulley when they are aligned. **See Figure 8.**

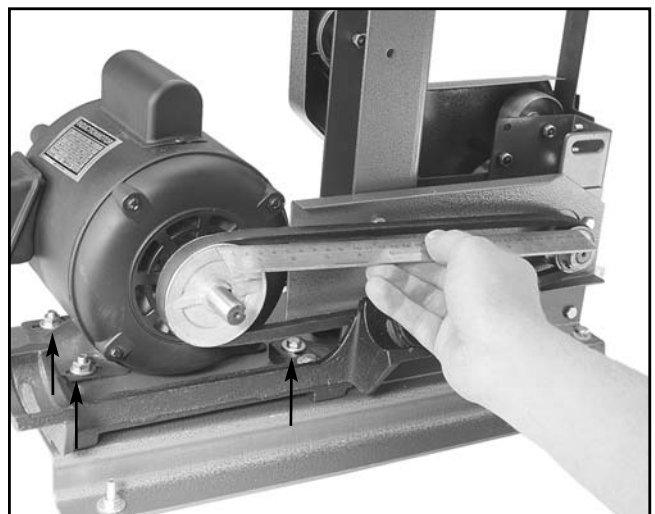

Figure 8. Inspecting pulley alignment.

8. Move the motor back to set the belt tension. The belt should deflect about $\frac{1}{2}$ " per side when squeezed in the middle with moderate pressure. Tighten the motor down when tension is correct.

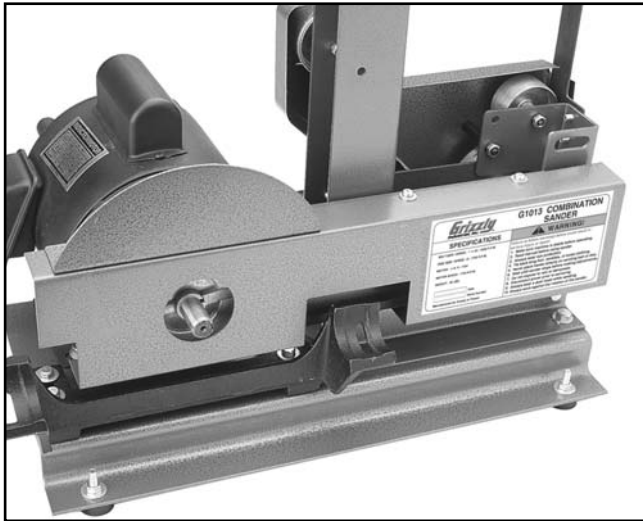

Figure 9. Belt guard attached to sander.

9. Attach the belt guards as shown in **Figure 9**. Secure with four (4) M5-0.8 x 6mm Phillips® head screws and 5mm washers.
10. Install the belt table using the $\frac{5}{16}$ " - 18 x $\frac{5}{8}$ " carriage bolt, $\frac{5}{16}$ " fender washer and $\frac{5}{16}$ " - 18 hex nut. **See Figure 10**.

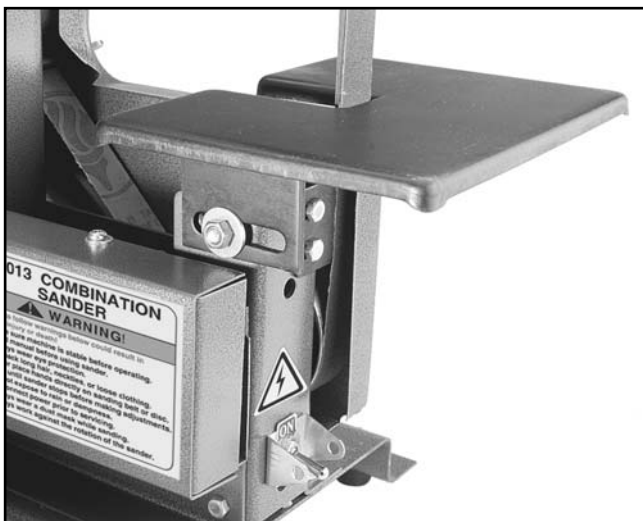

Figure 10. Belt table attached to sander.

11. Slide the 8" aluminum disc onto the motor shaft. Lightly tap into place with a rubber mallet if necessary. Align the disc and motor shaft keyways and insert the $\frac{3}{16}$ " square key. Secure the disc with a $\frac{1}{4}$ " - 20 x $\frac{3}{8}$ " setscrew. **See Figure 11**.

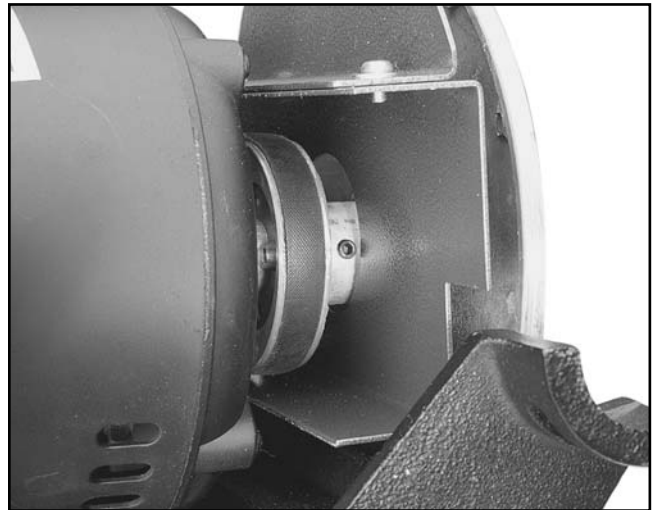

Figure 11. 8" disc attached to motor.

12. Peel the backing from the new sanding disc paper and stick it to the Aluminum Disc.
13. Secure the Disc Table to its support bracket using the two (2) $\frac{1}{4}$ " - 20 x $1\frac{1}{4}$ " carriage bolts, two (2) $\frac{1}{4}$ " flat washers and two (2) $\frac{1}{4}$ " - 20 wing nuts. **See Figure 12**.

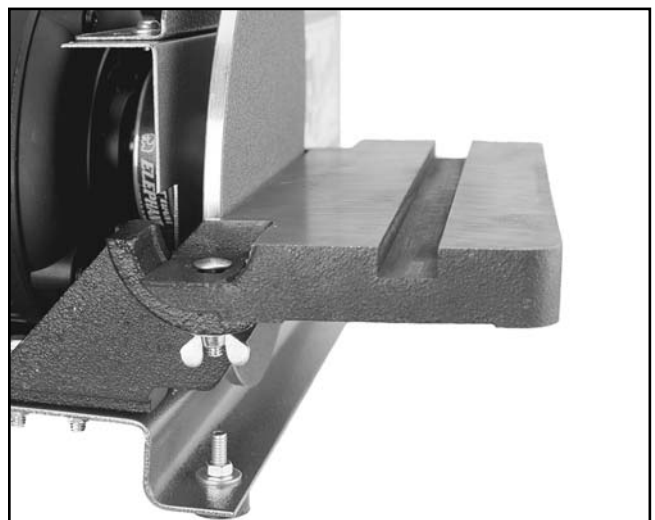

Figure 12. Disc table attachment.

14. Align the table so that there is a $\frac{1}{16}$ " gap between the 8" disc and the table. See **Figure 13**. Tighten the bolts that secure the table support bracket to the base.



Figure 13. Table aligned with sanding disc.

⚠️ WARNING

DO NOT attempt to connect or adjust wiring with the cordset plugged into its power source. Serious danger of electrocution could result.

15. Wire the motor by removing the motor junction box cover and feed the power cord from the bottom of the junction box. Connect the wires according to the Wiring Diagram Insert included with this manual. If this insert is missing, contact the appropriate service center listed in the Introduction for a replacement. See **Figure 14**.



Figure 14. Cordset connection at motor.



SECTION 5: Adjustments

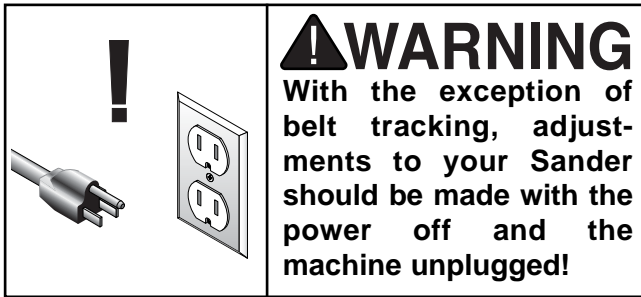

Belt Tracking

The idler and drive rollers are slightly crowned to keep the belt centered on the rollers. This will not correct improper tracking. Tracking must be periodically adjusted (particularly after belt replacement) to keep the belt properly aligned to the rollers and the platen. To adjust tracking:

1. **Unplug the machine!**
2. Remove the Sanding Belt Table and Sanding Belt Guards.
2. Turn the 8" disc by hand to observe lateral belt drift. DO NOT turn the sander on to inspect for belt drift.
3. By sight, center the Sanding Belt by adjusting the tracking knob. **See Figure 15.**

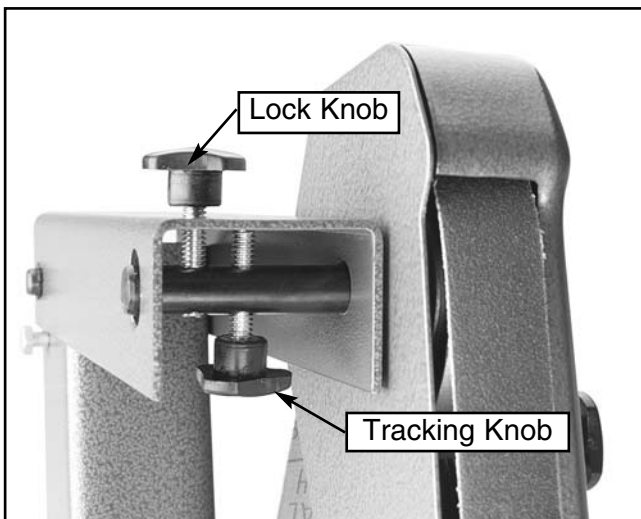

Figure 15. Location of tracking adjustments.

4. Move hands away from 8" disc.
5. Plug sander into power and turn machine on and off quickly. Inspect tracking.
6. Repeat steps 1-5 until the belt is centered on the rollers.

If the belt tracks properly on the two front rollers, but not on the rear roller, the rear roller must be adjusted. The roller shaft axle is slightly bent. By turning the axle, belt tracking will be affected.

1. Turn off the sander and disconnect it from its power source.
2. Remove rear belt guard.
3. Using a 10mm wrench, turn the rear axle nut. **See Figure 16.**
4. Keep rotating by hand until the sanding belt rides in the center of the roller.
5. Replace the rear belt guard.

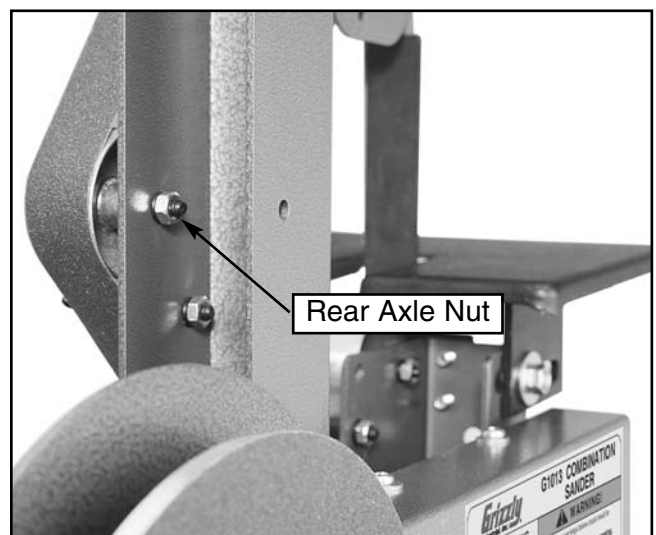

Figure 16. Adjusting rear axle.



Belt Table Tilt

Once you have turned off the switch and disconnected the sander from its power source:

1. Loosen the hex nut as shown in **Figure 18**.
2. Tilt the table to the desired position.
3. Tighten the hex nut.

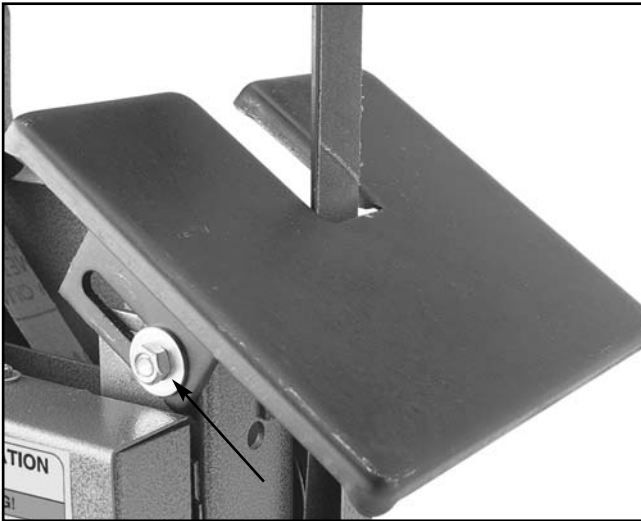

Figure 18. Belt table in tilted position.



Belt Replacement

Once you have turned off the switch and disconnected the sander from its power source:

1. Remove the two Sanding Belt Guards.
2. Press down on the top arm to release the belt tension and remove the old belt. **See Figure 17.**

Note: you may find it easier to remove and replace the belt with the belt table either tipped down to 45° or completely removed.

3. Install new belt. Arrows on underside of the belt should point in the direction of roller travel. If your belt has no arrows, install it so that the overlap on the seam travels downward (when facing the machine). Otherwise the paper will catch on your stock and rip. Release the arm.
4. Replace the Sanding Belt Guards.

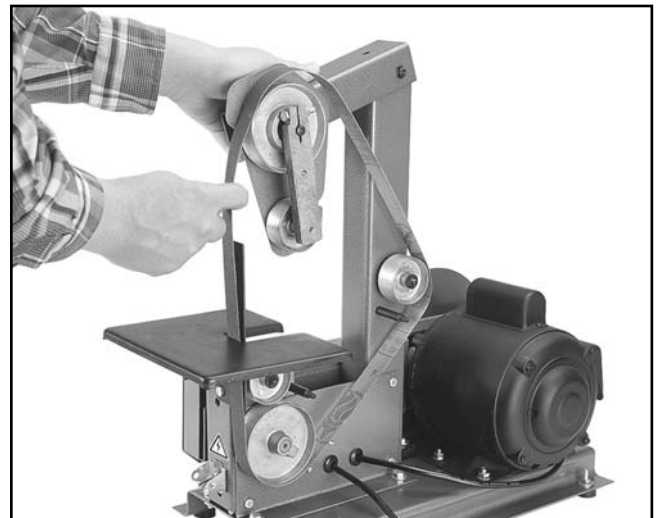

Figure 17. Sanding belt removal.



Disc Table Tilt

Once you have turned off the switch and disconnected the sander from its power source:

1. Loosen the two wing nuts under the sanding disc table. **See Figure 19.**
2. Tilt the table to the desired position.
3. Tighten the wing nuts.



Figure 19. Disc table in tilted position.



Disc Replacement

Once you have turned off the switch and disconnected the sander from its power source:

1. Remove the Sanding Disc Table.
2. Peel off the old Sanding Disc. Remove the backing from the new Disc, center it and press it firmly into place.
3. It may become necessary to remove the Aluminum Disc from the Motor Shaft because the Sanding Disc cannot be peeled off or the Aluminum Disc requires cleaning. *Do not* use petroleum-based solvents to clean the surface of the aluminum disc. This adversely affects adhesion.



SECTION 6: Operations

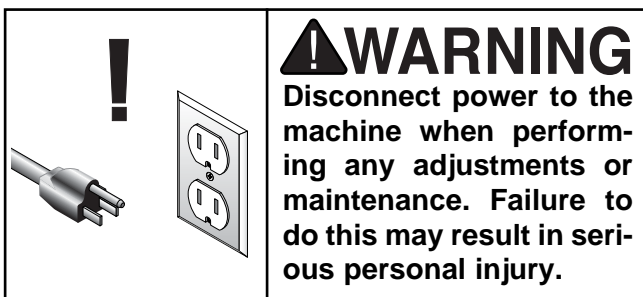
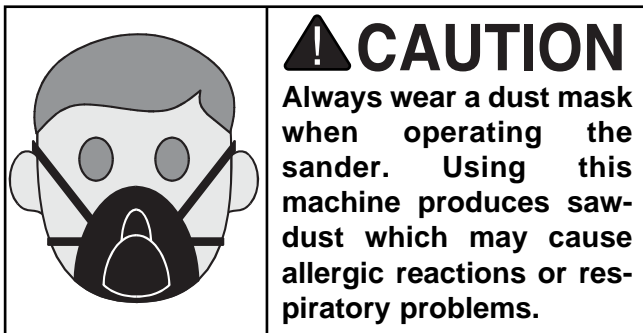
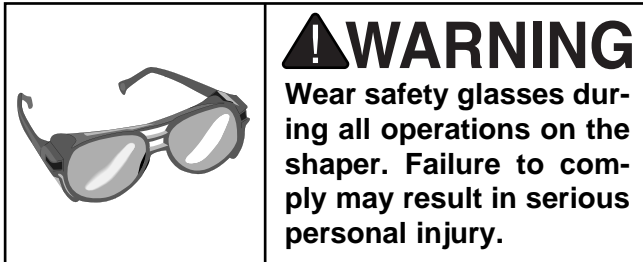

Test-Run

Before you put your Combination Sander into use, give it a quick inspection with the machine switched off and disconnected from its power source.

1. Are all fasteners tight?
2. Is the sanding belt properly tracked and tensioned?
3. Rotate disc slowly by hand. Look and listen for any scraping noises or anything that impedes smooth movement. Make appropriate adjustments before attempting to run the machine.
4. If the sander appears to be free of problems that might affect its operation, plug it in to its power source and start the machine. Be sure to keep a finger on the OFF button, just in case of a problem with the machine. Run the sander briefly to allow inspection of belt tracking.
5. Turn off the machine, disconnect it from its power source, and re-inspect for loose fasteners. If the tracking is not correct, refer to the tracking adjustment guidelines in the **Adjustments** section.

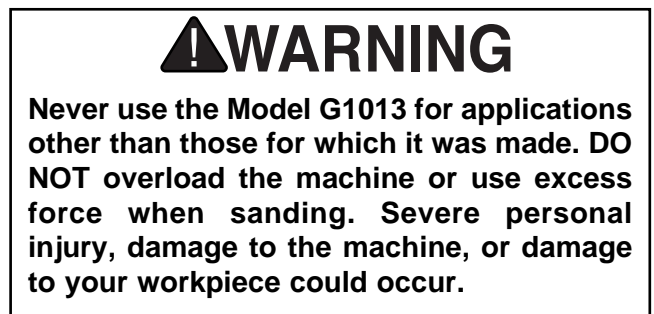

General Sanding

For general wood sanding, position and secure table, turn the machine on, and slowly feed your workpiece into the belt or disc. For disc sanding, note the direction of the disc rotation and be sure to feed your workpiece into the disc's downward spin. Also, be sure to keep the work table about $\frac{1}{16}$ " away from the belt or disc.



Contour Sanding

Remove platen and move Small Upper Idler Roller rearward so the workpiece will not be accidentally forced against it. Slowly feed the workpiece into the belt; the belt will follow the contour of the workpiece. **See Figure 20.**

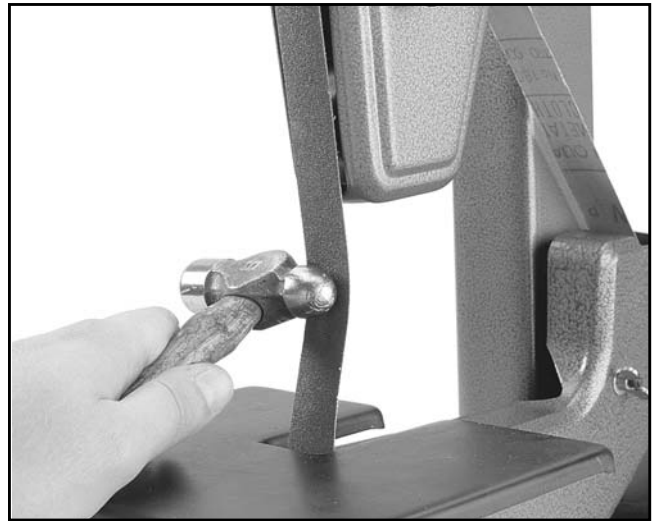

Figure 20. Contour sanding.



Inside Sanding

To sand or grind an interior work area, the sanding belt must be fed through the workpiece and remounted on its rollers. Depending on your application, you may either remove the platen or keep it in place.

1. Remove the Belt Sanding Table and the Belt Guards.
2. Feed the Sanding Belt through the workpiece and over the Upper Idler Roller. Loosen the Small Upper Idler Roller, swing it toward the front of the machine, and feed the belt around the pulley.
3. Press down on the top arm and feed the remainder of the belt through the rollers as shown in **Figure 21**.
4. Replace guards and table.
5. Adjust belt tracking as described in **Adjustments** section.

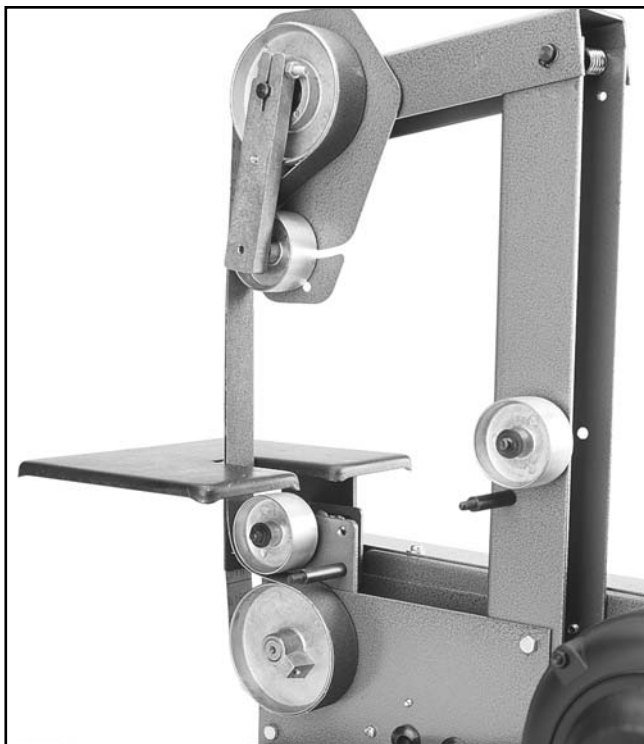

Figure 21. Belt arrangement for inside sanding.



Sharpening

Tilt the table to the desired sharpening angle and secure it. Using C-Clamps, attach a suitable wood scrap to the table. **See Figure 22.** This acts as an auxiliary table to support the workpiece. This table should be $\frac{1}{16}$ " away from the belt. It may be necessary to cut a notch in your auxiliary table to achieve this clearance.



Figure 22. False table for sharpening support.



SECTION 7: MAINTENANCE

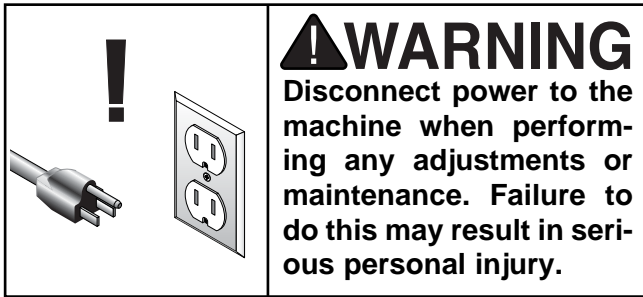

General

Make a habit of inspecting your sander each time you use it. Check for the following conditions and repair or replace when necessary.

1. Loose mounting bolts.
2. Worn switch.
3. Worn or damaged cords and plugs.
4. Worn or damaged V-belt.
5. Poor belt tensioning / tracking.



Table

The working table and other non-painted surfaces on the Model G1013 should be protected against rust and pitting. Wiping the sander clean after every use ensures that sawdust is not allowed to trap moisture against bare metal surfaces.

Tables can be kept rust-free with regular applications of products like Boeshield® T-9. For long term storage you may want to consider products like Kleen Bore's Rust Guardit™.



Lubrication

Your combination sander is equipped with shielded and pre-lubricated ball bearings that require no lubrication for the life of the bearings. All bearings are common sizes and are readily available from a local bearing supply house or our Service Department. The roller shafts, however, will benefit from regular applications of light machine oil. See Figure 23.

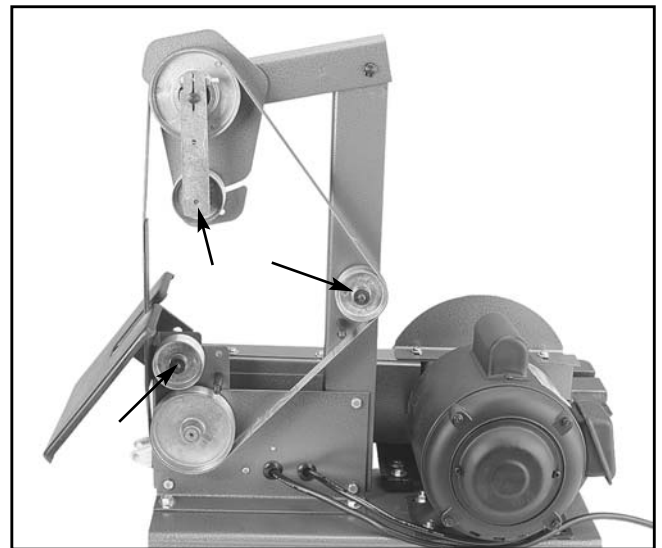

Figure 23. Lubrication points.



SECTION 8: CLOSURE

The following pages contain general machine data, parts diagrams/lists, troubleshooting guide and Warranty/Return information for your Model G1013 Combination Sander.

If you need parts or help in assembling your machine, or if you need operational information, we encourage you to call our Service Department. Our trained service technicians will be glad to help you.

If you have comments dealing specifically with this manual, please write to our Bellingham, Washington location using the address in *Section 3: Introduction*. The specifications, drawings, and photographs illustrated in this manual represent the Model G1013 as supplied when the manual was prepared. However, due to Grizzly's policy of continuous improvement, changes may be made at any time with no obligation on the part of Grizzly. Whenever possible, though, we send manual updates to all owners of a particular tool or machine. Should you receive one, add the new information to this manual and keep it for reference.

We have included some important safety measures that are essential to this machine's operation. While most safety measures are generally universal, Grizzly reminds you that each workshop is different and safety rules should be considered as they apply to your specific situation.

WARNING

Operating this equipment has the potential to launch flying debris which could cause eye injury. Always wear safety glasses or goggles when operating equipment. Everyday glasses or reading glasses only have impact resistant lenses, they are not safety glasses. Be certain the safety glasses you wear meet the appropriate standards of the American National Standards Institute (ANSI).

We recommend you keep a copy of our current catalog for complete information regarding Grizzly's warranty and return policy. If you need additional technical information relating to this machine, or if you need general assistance or replacement parts, please contact the Service Department listed in *Section 3: Introduction*.

Additional information sources are necessary to realize the full potential of this machine. Trade journals, woodworking magazines, and your local library are good places to start.

WARNING

The Model G1013 was specifically designed for sanding operations only. DO NOT MODIFY AND/OR USE THIS MACHINE FOR ANY OTHER PURPOSE. Modifications or improper use of this tool will void the warranty. If you are confused about any aspect of this machine, DO NOT use it until you have answered all your questions. Serious personal injury may occur.

WARNING

Like all power tools, there is danger associated with the Model G1013 Combination Sander. Accidents are frequently caused by lack of familiarity or failure to pay attention. Use this tool with respect and caution to lessen the possibility of operator injury. If normal safety precautions are overlooked or ignored, serious personal injury may occur.





MACHINE DATA SHEET

Customer Service #: (570) 326-3806 • To Order Call: (800) 523-4777 • Fax #: (800) 438-5901

GRIZZLY MODEL G1013 COMBINATION SANDER

Design Type..... Bench Model

Overall Dimensions:

Base10" x 18"
Height21"
Width15"
Length24"
Table (Disc)5" x 12½"
Table (Belt)..... 6½" x 8"
Container Dimensions.....10" x 19½" x 21"
Weight55 lbs.
Foot Print18" x 10"

Capacities:

Sanding Belt1" x 42"
Sanding Belt Speed4000 F.P.M.
Aluminum Disc8" Diameter
Aluminum Disc Speed1720 R.P.M.
Miter Gauge Groove.....¾" x ¾"
Miter Gauge.....Die Cast Plastic / Aluminum Bar
Table Tilt Range0° - 45°

Construction:

BaseStamped Steel
Table (Disc).....Ground Cast Iron
Stand.....Stamped Steel
Table (Belt)Stamped Steel

Motor:

TypeCapacitor Start Induction
Horsepower½ H.P.
Voltage110V
Amps.....12
Cycle and R.P.M.60 Hertz / 1720 R.P.M.
SwitchOn / Off Toggle
Power TransferBelt Drive
BearingsSealed, Permanently Lubricated

Specifications, while deemed accurate, are not guaranteed.

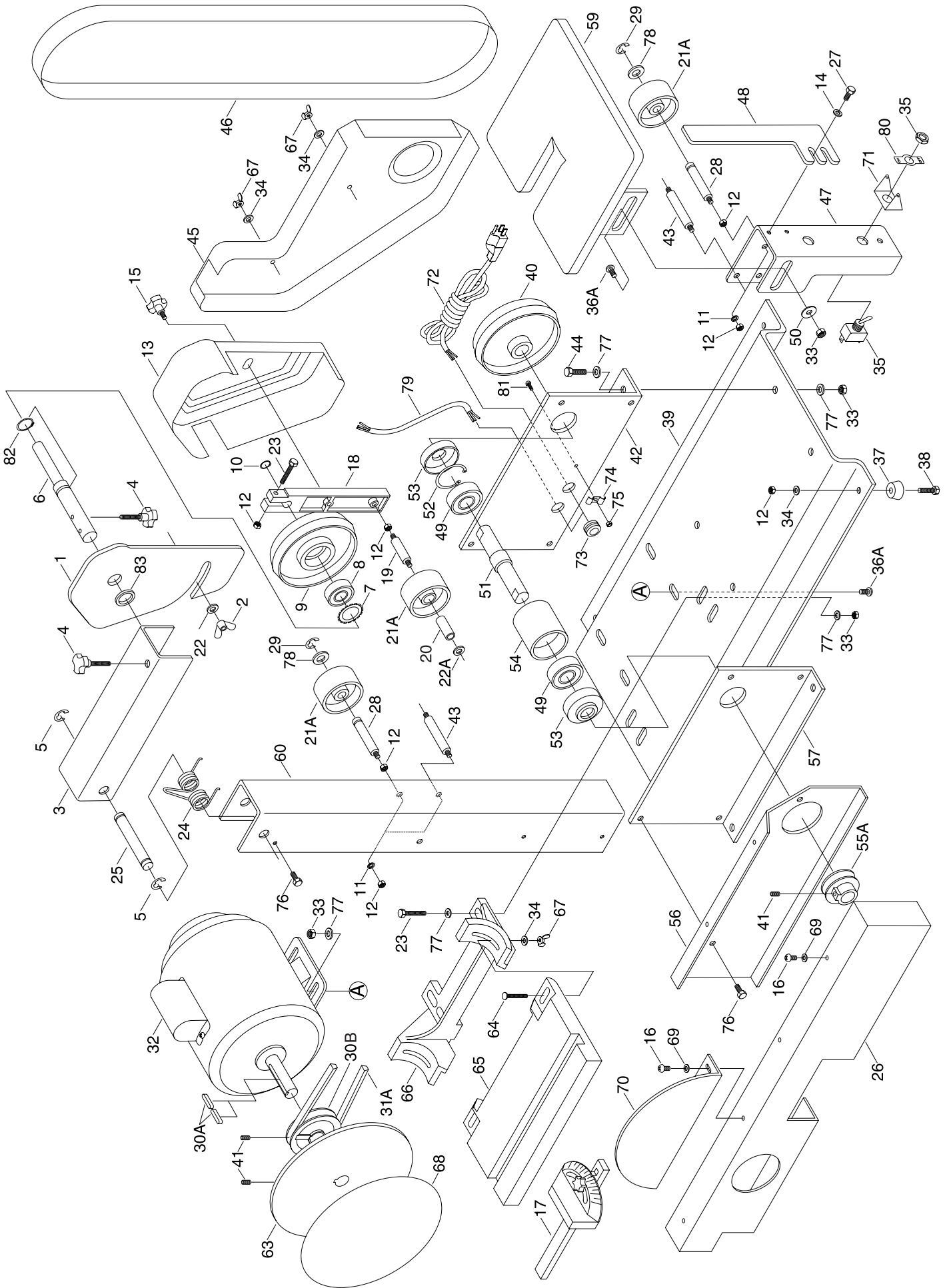

PARTS LIST

REF	PART #	DESCRIPTION
1	P1013001	GUARD BACK
2	PWN01	WING NUT 10-24
3	P1013003	TOP PIVOT BRACKET
4	P1013004	KNOB BOLT 1/4"-20 X 1"
5	PEC03M	E-CLIP 10mm
6	P1013006	UPPER WHEEL SHAFT
7	P1013007	SPECIAL CLIP
8	P6200	BEARING 6200-2RS
9	P1013009	TOP WHEEL
10	PR01M	SNAP RING 10mm
11	PLW02	LOCK WASHER 1/4"
12	PN05	HEX NUT 1/4" - 20
13	P1013013	UPPER GUARD
14	PW03M	FLAT WASHER 6mm
15	P1013015	KNOB BOLT 1/4"-20 X 1/2"
16	PS19M	PHLP HD SCR M5 - 0.8 x 6
17	P1013017	COMPLETE MITER GAUGE
18	P1013018	TOP ARM
19	P1013019	IDLER SHAFT
20	P1013020	SLEEVE BEARING
21A	P1013021A	IDLER WHEEL
22	PW03	FLAT WASHER #10
22A	P1012022A	PLASTIC WASHER
23	PB12	HEX BOLT 5/16" - 18 x 1 1/4"
24	P1013024	TORSION SPRING
25	P1013025	PIVOT ARM SHAFT
26	P1013026	BELT GUARD
27	PB04M	HEX BOLT M6 - 1.0 x 10
28	P1013028	IDLER SHAFT
29	PEC07M	E-CLIP 7mm
30A	PK34M	KEY 5 x 5 x 20mm
30B	P1013030B	MOTOR PULLEY
31A	PVM30	V-BELT M-30
32	P1013032	MOTOR 1/2 HP
33	PN02	HEX NUT 5/16" - 18
34	PW06	FLAT WASHER 1/4"
35	PSW05	SWITCH W/MOUNTING NUT
36A	PCB01	CARRIAGE BOLT 5/16"-18x 5/8"
37	P1013037	RUBBER FOOT
38	PB31	HEX BOLT 1/4" - 20 x 1"
39	P1013039	BASE

REF	PART #	DESCRIPTION
40	P1013040	DRIVE WHEEL
41	PSS03	SETSCREW 1/4" - 20 x 3/8"
42	P1013042	PLATE, RIGHT HAND
43	P1013043	GUARD SUPPORT
44	PB07	HEX BOLT 5/16" - 18 x 3/4"
45	P1013045	LOWER GUARD
46	G1209	SANDING BELT
47	P1013047	TABLE SUPPORT
48	P1013048	BELT PLATEN
49	P6202	BEARING 6202-2RS
50	P1013050	FENDER WASHER 5/16"
51	P1013051	SHAFT
52	PR05M	SNAP RING 15mm
53	P1013053	BEARING CAP
54	P1013054	ARBOR BEARING HOUSING
55A	P1013055A	PULLEY
56	P1013056	GUARD BRACKET
57	P1013057	PLATE, LEFT HAND
59	P1013059	BELT TABLE
60	P1013060	COLUMN CHANNEL
63	P1013063	8" ALUMINUM DISC
64	PCB07	CARRIAGE BOLT 1/4" - 20 x 1 1/4"
65	P1013065	DISC TABLE
66	P1013066	TABLE SUPPORT
67	PWN02	WING NUT 1/4" - 20
68	G1212	8" SAND DISC
69	PW02M	FLAT WASHER 5mm
70	P1013070	DISC COVER
71	P1013071	SWITCH COVER
72	P1013072	POWER CORD
73	P1013073	BUSHING
74	P1013074	CORD SUPPORT
75	PN07	HEX NUT 10 - 24
76	PB02M	HEX BOLT M6-1.0 x 12
77	PW07	FLAT WASHER 5/16"
78	P1013078	RUBBER WASHER
79	P1013079	MOTOR CORD
80	P1013080	ON/OFF LABEL
81	PS08	PHLP HD SCR 10 - 24 x 3/4"
82	PR03M	SNAP RING 12mm
83	P1013083	SPACER

WARRANTY AND RETURNS

Grizzly Industrial, Inc. warrants every product it sells for a period of **1 year** to the original purchaser from the date of purchase. This warranty does not apply to defects due directly or indirectly to misuse, abuse, negligence, accidents, repairs or alterations or lack of maintenance. This is Grizzly's sole written warranty and any and all warranties that may be implied by law, including any merchantability or fitness, for any particular purpose, are hereby limited to the duration of this written warranty. We do not warrant or represent that the merchandise complies with the provisions of any law or acts unless the manufacturer so warrants. In no event shall Grizzly's liability under this warranty exceed the purchase price paid for the product and any legal actions brought against Grizzly shall be tried in the State of Washington, County of Whatcom.

We shall in no event be liable for death, injuries to persons or property or for incidental, contingent, special, or consequential damages arising from the use of our products.

To take advantage of this warranty, contact us by mail or phone and give us all the details. We will then issue you a "Return Number," which must be clearly posted on the outside as well as the inside of the carton. We will not accept any item back without this number. Proof of purchase must accompany the merchandise.

The manufacturers reserve the right to change specifications at any time because they constantly strive to achieve better quality equipment. We make every effort to ensure that our products meet high quality and durability standards and we hope you never need to use this warranty.

Please feel free to write or call us if you have any questions about the machine or the manual.

Thank you again for your business and continued support. We hope to serve you again soon.

WARRANTY CARD

Name _____
Street _____
City _____ State _____ Zip _____
Phone Number _____ E-Mail _____ FAX _____
MODEL# _____ **SERIAL#** _____ **Order** _____

The following information is given on a voluntary basis. It will be used for marketing purposes to help us develop better products and services. Of course, all information is strictly confidential.

- How did you learn about us?
 Advertisement Friend
 Catalog Card Deck
 World Wide Web
 Other _____
- Which of the following magazines do you subscribe to.
 American Woodworker Practical Homeowner
 Cabinetmaker Shop Notes
 Family Handyman Today's Homeowner
 Fine Homebuilding WOOD
 Fine Woodworking Wooden Boat
 Home Handyman Woodshop News
 Journal of Light Construction Woodsmith
 Old House Journal Woodwork
 Popular Mechanics Woodworker
 Popular Science Woodworker's Journal
 Popular Woodworking Workbench
 Other _____
- Which of the following woodworking/remodeling shows do you watch?
 Backyard America The New Yankee Workshop
 Home Time This Old House
 The American Woodworker Woodwright's Shop
 Other _____
- What is your annual household income?
 \$20,000-\$29,999 \$60,000-\$69,999
 \$30,000-\$39,999 \$70,000-\$79,999
 \$40,000-\$49,999 \$80,000-\$89,999
 \$50,000-\$59,999 \$90,000 +
- What is your age group?
 20-29 50-59
 30-39 60-69
 40-49 70 +
- How long have you been a woodworker?
 0 - 2 Years 8 - 20 Years
 2 - 8 Years 20+ Years
- How would you rank your woodworking skills?
 Simple Advanced
 Intermediate Master Craftsman
- What stationary woodworking tools do you own? Check all that apply.
 Air Compressor Panel Saw
 Band Saw Planer
 Drill Press Power Feeder
 Drum Sander Radial Arm Saw
 Dust Collector Shaper
 Horizontal Boring Machine Spindle Sander
 Jointer Table Saw
 Lathe Vacuum Veneer Press
 Mortiser Wide Belt Sander
 Other _____
- How many of your woodworking machines are Grizzly? _____
- Which benchtop tools do you own? Check all that apply.
 1" x 42" Belt Sander 6" - 8" Grinder
 5" - 8" Drill Press Mini Lathe
 8" Table Saw 10" - 12" Thickness Planer
 8" - 10" Bandsaw Scroll Saw
 Disc/Belt Sander Spindle/Belt Sander
 Mini Jointer
 Other _____
- How many of the machines checked above are Grizzly? _____
- Which portable/hand held power tools do you own? Check all that apply.
 Belt Sander Orbital Sander
 Biscuit Joiner Palm Sander
 Circular Saw Portable Planer
 Detail Sander Saber Saw
 Drill/Driver Reciprocating Saw
 Miter Saw Router
 Other _____
- What machines/supplies would you like Grizzly Industrial to carry?

- What new accessories would you like Grizzly Industrial to carry?

- What other companies do you purchase your tools and supplies from?

- Do you think your purchase represents good value?
 Yes No
- Would you recommend Grizzly Imports to a friend?
 Yes No
- Would you allow us to use your name as a reference for Grizzly customers in your area? **Note: We never use names more than three times.**
 Yes No
- Comments: _____

CUT ALONG DOTTED LINE

FOLD ALONG DOTTED LINE

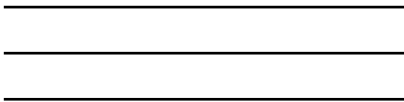

Place
Stamp
Here



**GRIZZLY INDUSTRIAL, INC.
P.O. BOX 2069
BELLINGHAM, WA 98227-2069**



FOLD ALONG DOTTED LINE

Send a Grizzly Catalog to a friend:

Name	_____
Street	_____
City	_____
State	_____
Zip	_____

TAPE ALONG EDGES--PLEASE DO NOT STAPLE

Free Manuals Download Website

<http://myh66.com>

<http://usermanuals.us>

<http://www.somanuals.com>

<http://www.4manuals.cc>

<http://www.manual-lib.com>

<http://www.404manual.com>

<http://www.luxmanual.com>

<http://aubethermostatmanual.com>

Golf course search by state

<http://golfingnear.com>

Email search by domain

<http://emailbydomain.com>

Auto manuals search

<http://auto.somanuals.com>

TV manuals search

<http://tv.somanuals.com>