

# *Grizzly* **Industrial, Inc.**®

## **ROUTER TABLE MODEL G0528 INSTRUCTION MANUAL**



COPYRIGHT © SEPTEMBER, 2003 BY GRIZZLY INDUSTRIAL, INC.  
**WARNING: NO PORTION OF THIS MANUAL MAY BE REPRODUCED IN ANY SHAPE  
OR FORM WITHOUT THE WRITTEN APPROVAL OF GRIZZLY INDUSTRIAL, INC.**  
#TR5457 REVISED MAY, 2004. PRINTED IN TAIWAN

# WARNING

Some dust created by power sanding, sawing, grinding, drilling, and other construction activities contains chemicals known to the State of California to cause cancer, birth defects or other reproductive harm. Some examples of these chemicals are:

- Lead from lead-based paints.
- Crystalline silica from bricks, cement, and other masonry products.
- Arsenic and chromium from chemically treated lumber.

Your risk from these exposures varies, depending on how often you do this type of work. To reduce your exposure to these chemicals: work in a well ventilated area, and work with approved safety equipment, such as those dust masks that are specially designed to filter out microscopic particles.

# Table of Contents

<b>SECTION 1: SAFETY</b> .....	<b>2</b>
Safety Instructions For Power Tools .....	2
Additional Safety Instructions For Router Tables.....	4
<b>SECTION 2: INTRODUCTION</b> .....	<b>5</b>
Commentary .....	5
<b>SECTION 3: CIRCUIT REQUIREMENTS</b> .....	<b>6</b>
General.....	6
Electrical.....	6
<b>SECTION 4: MACHINE FEATURES</b> .....	<b>7</b>
<b>SECTION 5: SET UP</b> .....	<b>8</b>
G0528 Inventory.....	8
Hardware Recognition Chart.....	9
Clean Up .....	10
Site Considerations .....	10
Assembly.....	11
Rubber Feet .....	11
Cross Supports .....	12
Stand .....	13
Table Braces .....	13
Fence .....	14
Hold-Downs.....	14
Miter .....	15
Router To Table .....	15
Switch.....	16
Dust Port Hook-Up.....	17
<b>SECTION 6: OPERATIONS</b> .....	<b>18</b>
Before Routing .....	18
Routing.....	18
<b>SECTION 7: REFERENCE INFO</b> .....	<b>21</b>
G0528 Machine Data Sheet.....	22
G0528 Parts Breakdown .....	23
Warranty & Returns.....	26

# SECTION 1: SAFETY

## WARNING

### For Your Own Safety Read Instruction Manual Before Operating This Equipment

The purpose of safety symbols is to attract your attention to possible hazardous conditions. This manual uses a series of symbols and signal words which are intended to convey the level of importance of the safety messages. The progression of symbols is described below. Remember that safety messages by themselves do not eliminate danger and are not a substitute for proper accident prevention measures.



Indicates an imminently hazardous situation which, if not avoided, WILL result in death or serious injury.



Indicates a potentially hazardous situation which, if not avoided, COULD result in death or serious injury.



Indicates a potentially hazardous situation which, if not avoided, MAY result in minor or moderate injury. It may also be used to alert against unsafe practices.

**NOTICE**

This symbol is used to alert the user to useful information about proper operation of the equipment.

## WARNING

### Safety Instructions For Power Tools

- KEEP GUARDS IN PLACE** and in working order.
- REMOVE ADJUSTING KEYS AND WRENCHES.** Form a habit of checking to see that keys and adjusting wrenches are removed from tool before turning on.
- KEEP WORK AREA CLEAN.** Cluttered areas and benches invite accidents.
- NEVER USE IN DANGEROUS ENVIRONMENT.** DO NOT use power tools in damp or wet locations, or where any flammable or noxious fumes may exist. Keep work area well lighted.
- KEEP CHILDREN AND VISITORS AWAY.** All children and visitors should be kept at a safe distance from work area.
- MAKE WORKSHOP CHILD PROOF** with padlocks, master switches, or by removing starter keys.
- NEVER FORCE TOOL.** It will do the job better and safer at the rate for which it was designed.
- USE RIGHT TOOL.** DO NOT force tool or attachment to do a job for which it was not designed.

# WARNING

## Safety Instructions For Power Tools

9. **USE PROPER EXTENSION CORD.** Make sure your extension cord is in good condition. Conductor size should be in accordance with the chart below. The amperage rating should be listed on the motor or tool nameplate. An undersized cord will cause a drop in line voltage resulting in loss of power and overheating. Your extension cord must also contain a ground wire and plug pin. Always repair or replace extension cords if they become damaged.

Minimum Gauge for Extension Cords

AMP RATING	LENGTH		
	25ft	50ft	100ft
0-6	16	16	16
7-10	16	16	14
11-12	16	16	14
13-16	14	12	12
17-20	12	12	10
21-30	10	10	No

10. **WEAR PROPER APPAREL.** DO NOT wear loose clothing, gloves, neckties, rings, bracelets, or other jewelry which may get caught in moving parts. Non-slip footwear is recommended. Wear protective hair covering to contain long hair.
11. **ALWAYS USE SAFETY GLASSES.** Also use face or dust mask if cutting operation is dusty. Everyday eyeglasses only have impact resistant lenses, they are NOT safety glasses.
12. **SECURE WORK.** Use clamps or a vise to hold work when practical. It's safer than using your hand and frees both hands to operate tool.
13. **DO NOT OVER-REACH.** Keep proper footing and balance at all times.
14. **MAINTAIN TOOLS WITH CARE.** Keep tools sharp and clean for best and safest performance. Follow instructions for lubri-

cating and changing accessories.

15. **USE RECOMMENDED ACCESSORIES.** Consult the owner's manual for recommended accessories. The use of improper accessories may cause risk of injury.
16. **REDUCE THE RISK OF UNINTENTIONAL STARTING.** On machines with magnetic contact starting switches there is a risk of starting if the machine is bumped or jarred. Always disconnect from power source before adjusting or servicing. Make sure switch is in OFF position before reconnecting.
17. **CHECK DAMAGED PARTS.** Before further use of the tool, a guard or other part that is damaged should be carefully checked to determine that it will operate properly and perform its intended function. Check for alignment of moving parts, binding of moving parts, breakage of parts, mounting, and any other conditions that may affect its operation. A guard or other part that is damaged should be properly repaired or replaced.
18. **NEVER LEAVE TOOL RUNNING UNATTENDED. TURN POWER OFF.** DO NOT leave tool until it comes to a complete stop.
19. **NEVER OPERATE A MACHINE WHEN TIRED, OR UNDER THE INFLUENCE OF DRUGS OR ALCOHOL.** Full mental alertness is required at all times when running a machine.
20. **NEVER ALLOW UNSUPERVISED OR UNTRAINED PERSONNEL TO OPERATE THE MACHINE.** Make sure any instructions you give in regards to machine operation are approved, correct, safe, and clearly understood.
21. **IF AT ANY TIME YOU ARE EXPERIENCING DIFFICULTIES** performing the intended operation, stop using the machine! Then contact our service department or ask a

# **WARNING**

## **Additional Safety Instructions For Router Tables**

- 1. HAND POSITIONING.** Never pass your hands directly over or in front of the cutter. As one hand approaches cutter, move it in an arc motion away from the cutter to the outfeed side and reposition that hand beyond the cutter.
- 2. STOCK LENGTH.** Do not rout stock shorter than 12 inches without special fixtures or jigs. Where practical, rout longer stock and cut to size.
- 3. BLIND CUT WHENEVER POSSIBLE.** This keeps the cutters on the underside of the workpiece and provides a distance guard for the operator.
- 4. TEST ROTATION.** Always rotate the spindle by hand, with the machine unplugged, to test any new setup to ensure proper cutter clearance before starting the machine.
- 5. KEEP ANY UNUSED PORTION OF THE CUTTER BELOW THE TABLE SURFACE.**
- 6. DEPTH OF CUT.** Never remove too much material in one pass. Several light passes are safer and give a cleaner finish.
- 7. IF AT ANYTIME YOU ARE EXPERIENCING DIFFICULTIES PERFORMING THE INTENDED OPERATION, STOP USING THE ROUTER TABLE!** Then contact our service department or ask a qualified expert how the operation should be performed.
- 8. SAFETY DEVICES.** The use of push sticks as safety devices in some applications is smart; in others it can be quite dangerous. If the push stick comes in contact with the cutter on the end grain, it can fly out of your hand like a bullet, potentially causing serious injury.  
  
We recommend using some type of fixture, jig, or hold-down device as a safer alternative. Use a guard or other type of protective device at all times.
- 9. ALWAYS FEED AGAINST THE ROTATION OF THE CUTTER.**
- 10. DO NOT REMOVE THE RETRACTABLE GUARD ON THE FENCE.**
- 11. BE AWARE THAT CERTAIN WOODS MAY CAUSE AN ALLERGIC REACTION** in people and animals, especially when exposed to fine dust. Make sure you know what type of wood dust you will be exposed to, the possibility of a allergic reaction and always wear an approved respirator.
- 12. READ AND UNDERSTAND THE INSTRUCTION MANUAL SUPPLIED WITH THE ROUTER TO BE INSTALLED IN THIS TABLE.**
- 13. DO NOT REACH UNDER THE ROUTER TABLE WHILE THE ROUTER IS PLUGGED IN OR RUNNING.**

### **WARNING**

Unfamiliarity with this manual could result in serious personal injury. Read and become familiar with the contents of this manual, including all the safety warnings.

### **WARNING**

No list of safety guidelines can be complete. Operating this machinery may require additional safety precautions specific to your shop environment. Failure to use reasonable caution while operating this machine could result in serious personal injury.

# SECTION 2: INTRODUCTION

---

---

## Commentary

---

---

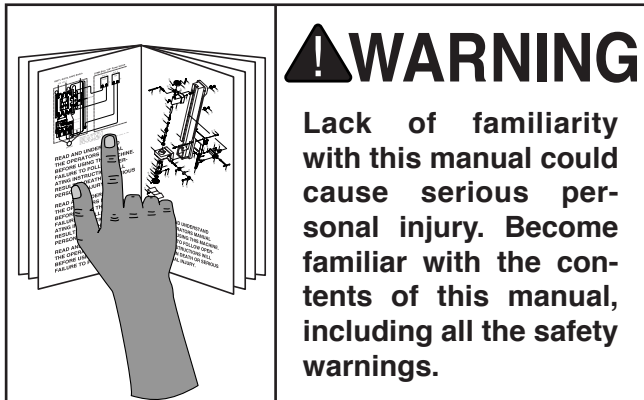

We are proud to offer the Model G0528 Router Table. This machine is part of a growing Grizzly family of fine woodworking machinery. When used according to the guidelines set forth in this manual, you can expect years of trouble-free, enjoyable operation and proof of Grizzly's commitment to customer satisfaction.

We are pleased to provide this manual with the Model G0528. It was written to guide you through assembly, review safety considerations, and cover general operating procedures. It represents our effort to produce the best documentation possible. If you have any comments regarding this manual, please write to us at the address below:

Grizzly Industrial, Inc.  
% Technical Documentation  
P.O. Box 2069  
Bellingham, WA 98227-2069

Most importantly, we stand behind our machines. If you have any service questions or parts requests, please call or write us at the location listed below.

Grizzly Industrial, Inc.  
1203 Lycoming Mall Circle  
Muncy, PA 17756  
Phone: (570) 546-9663  
Fax: (800) 438-5901  
E-Mail: [techsupport@grizzly.com](mailto:techsupport@grizzly.com)  
Web Site: <http://www.grizzly.com>

The specifications, drawings, and photographs illustrated in this manual represent the Model G0528 as supplied when the manual was prepared. However, owing to Grizzly's policy of continuous improvement, changes may be made at any time with no obligation on the part of Grizzly. For your convenience, we always keep current Grizzly manuals available on our website at [www.grizzly.com](http://www.grizzly.com). Any updates to your machine will be reflected in these manuals as soon as they are complete. Visit our site often to check for the latest updates to this manual!



# SECTION 3: CIRCUIT REQUIREMENTS

## General

### **⚠️ WARNING**

If the machine is wired incorrectly a fire could result. Make sure your wiring, receptacle, plug, and circuit breaker can handle the current draw of the machine. If you are not sure that your electrical circuit can handle the current draw, get a qualified electrician to test your electrical system and do any required upgrades. Do not attempt to modify an existing circuit by only replacing the circuit breaker with one rated for a higher amperage draw than the wiring, receptacle, and plug are rated for.

The Model G0528 power switch (page 16, Figure 13) is designed to accept 2-prong DOUBLE INSULATED plugs or 3-prong grounding type plugs. The power switch provides the convenience of switching power to the router at the front of the router table instead of having to reach under the table and locate the switch. The power switch also allows multiple devices such as lights or vacuums to be powered when the router is turned *ON*.



## Electrical

The power switch plugs into a wall outlet that is properly grounded as shown in **Figure 1**.

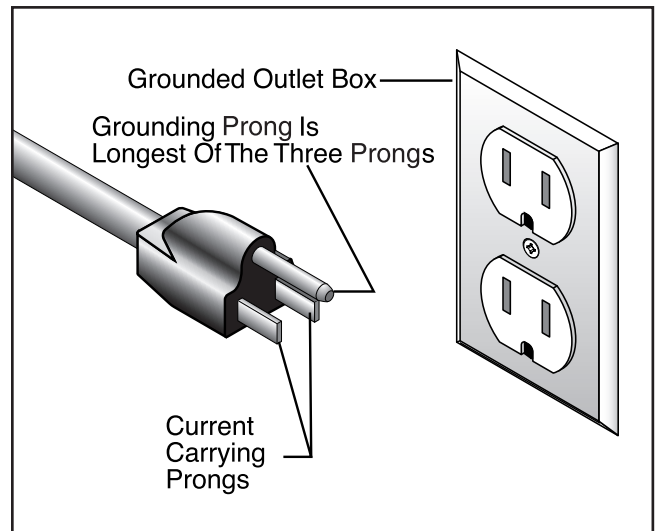

**Figure 1.** A 3-prong plug and ground outlet.





# SECTION 4: MACHINE FEATURES

Set up and operation instructions will be easier to understand if you become familiar with the location and names of the machine features shown in **Figure 2**.

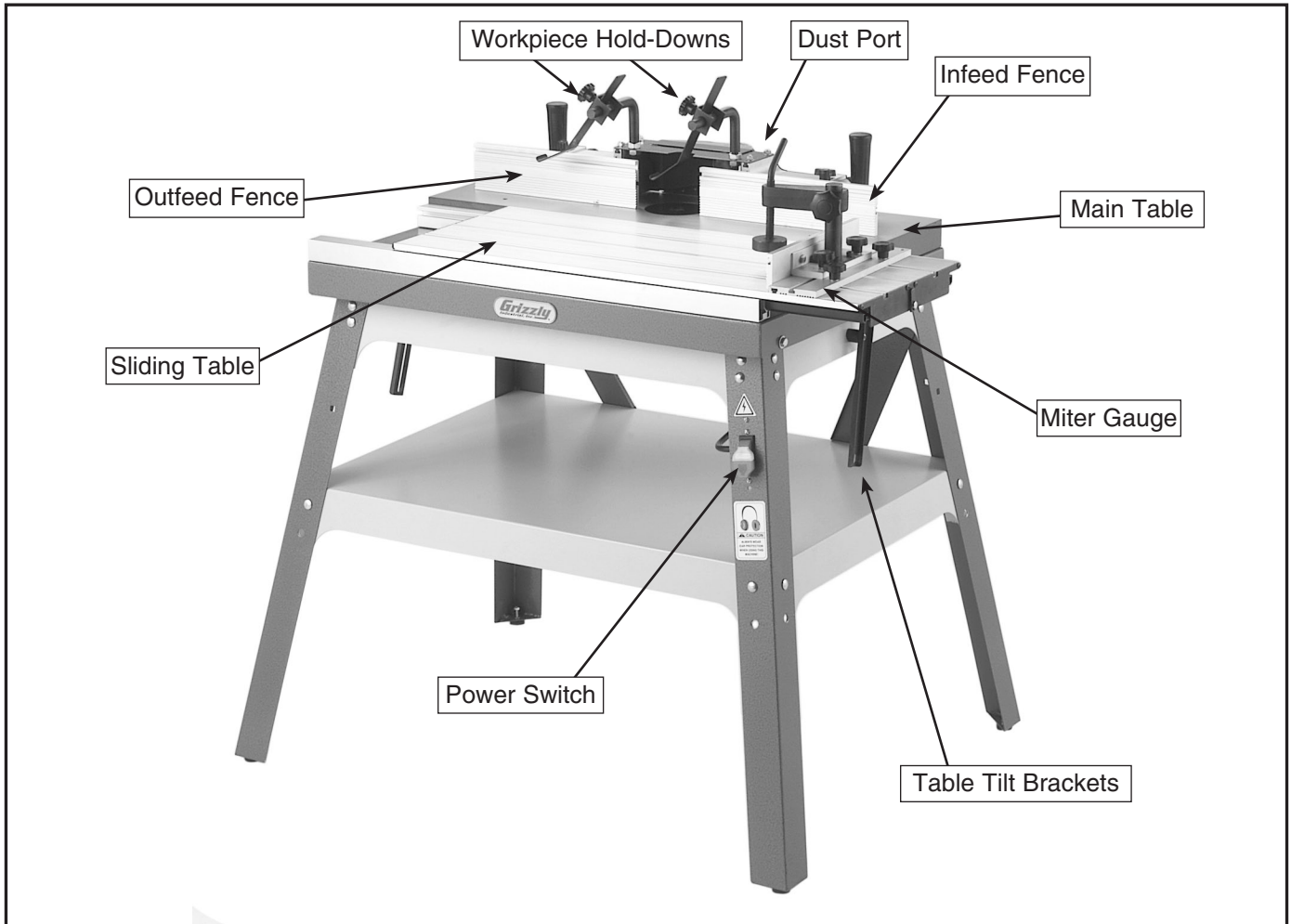

Figure 2. Machine features.



# SECTION 5: SET UP

## G0528 Inventory

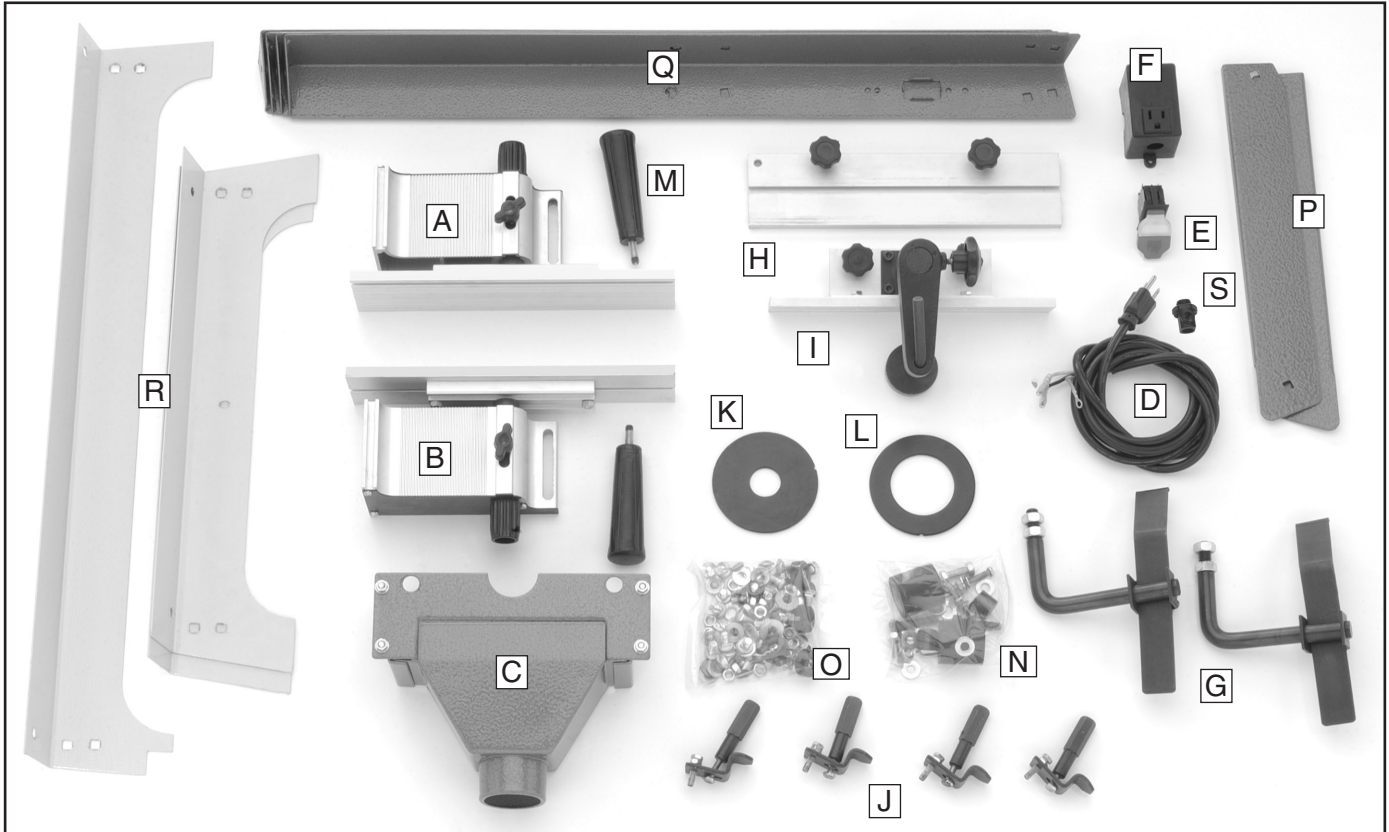















Figure 3. G0528 Inventory.

DESCRIPTION	QTY	DESCRIPTION	QTY
A. Left Fence .....	1	— Flat Washers $\frac{5}{16}$ " .....	8
B. Right Fence .....	1	— Cap Screws $\frac{5}{16}$ "-18 x $1\frac{1}{2}$ " .....	2
C. Dust Hood .....	1	— Spacers .....	2
D. Power Cord .....	1	O. Hardware Bag	
E. Switch .....	1	— Carriage Bolts $\frac{5}{16}$ "-18 x $\frac{1}{2}$ " .....	32
F. Switch Box.....	1	— Flat Washers $\frac{5}{16}$ " .....	32
G. Workpiece Hold-Downs.....	2	— Lock Washers $\frac{5}{16}$ " .....	32
H. Miter Plate .....	1	— Hex Nuts $\frac{5}{16}$ "-18 .....	32
I. Miter Fence .....	1	— Rubber Feet .....	4
J. Router Clamps .....	4	— Phillips Screws $\frac{1}{4}$ "-20 x 1" .....	4
K. 29MM Table Insert .....	1	— Flat Washers $\frac{1}{4}$ " .....	4
L. 60MM Table Insert .....	1	— Hex Nuts $\frac{1}{4}$ "-20 .....	4
M. Fence Lock Handles.....	2	P. Diagonal Supports.....	2
N. Hardware Bag		Q. Stand Legs .....	4
— Rubber Stops .....	2	R. Cross Supports.....	4
— Phillips Screws $\frac{1}{4}$ "-20 x $1\frac{1}{2}$ " .....	2	S. Strain Relief.....	1
— Flat Washers $\frac{1}{4}$ " .....	4		
— Hex Nuts $\frac{1}{4}$ "-20 .....	2		
— Hex Bolts $\frac{5}{16}$ "-18 x 1" .....	2		
— Hex Nuts $\frac{5}{16}$ "-18 .....	4		

# Hardware Recognition Chart

USE THIS CHART TO MATCH UP HARDWARE DURING THE ASSEMBLY PROCESS!

MEASURE BOLT DIAMETER BY PLACING INSIDE CIRCLE

-  #10
-  1/4"
-  5/16"
-  3/8"
-  7/16"
-  1/2"
-  5/8"
-  4mm
-  6mm
-  8mm
-  10mm
-  12mm
-  16mm

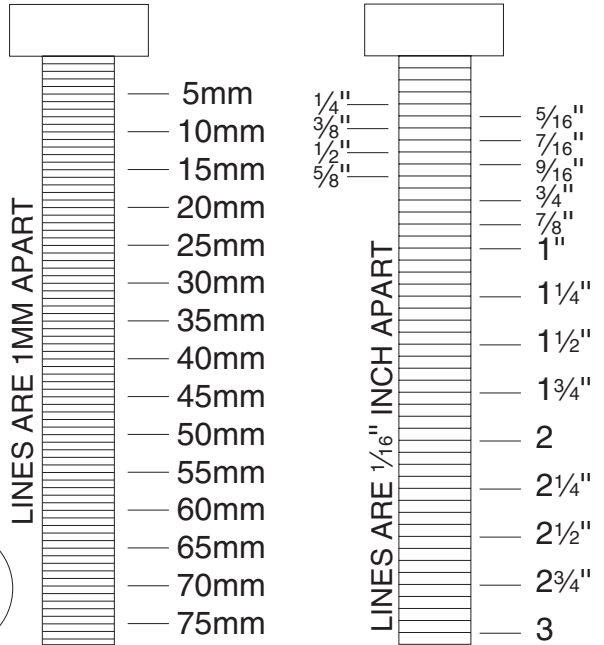
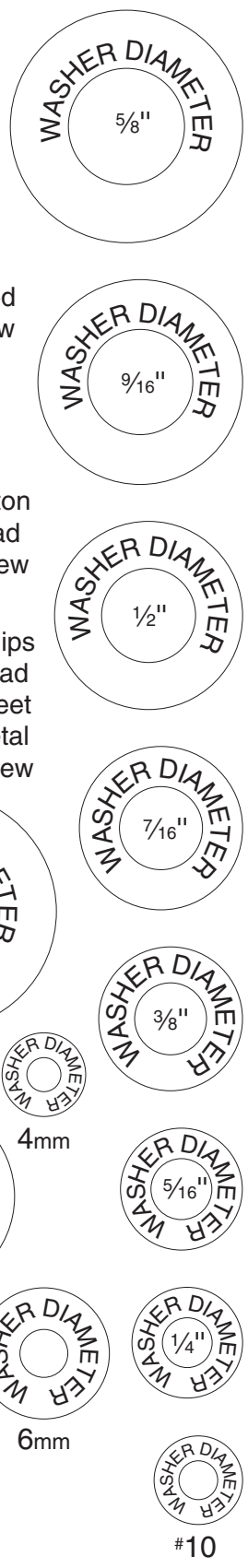
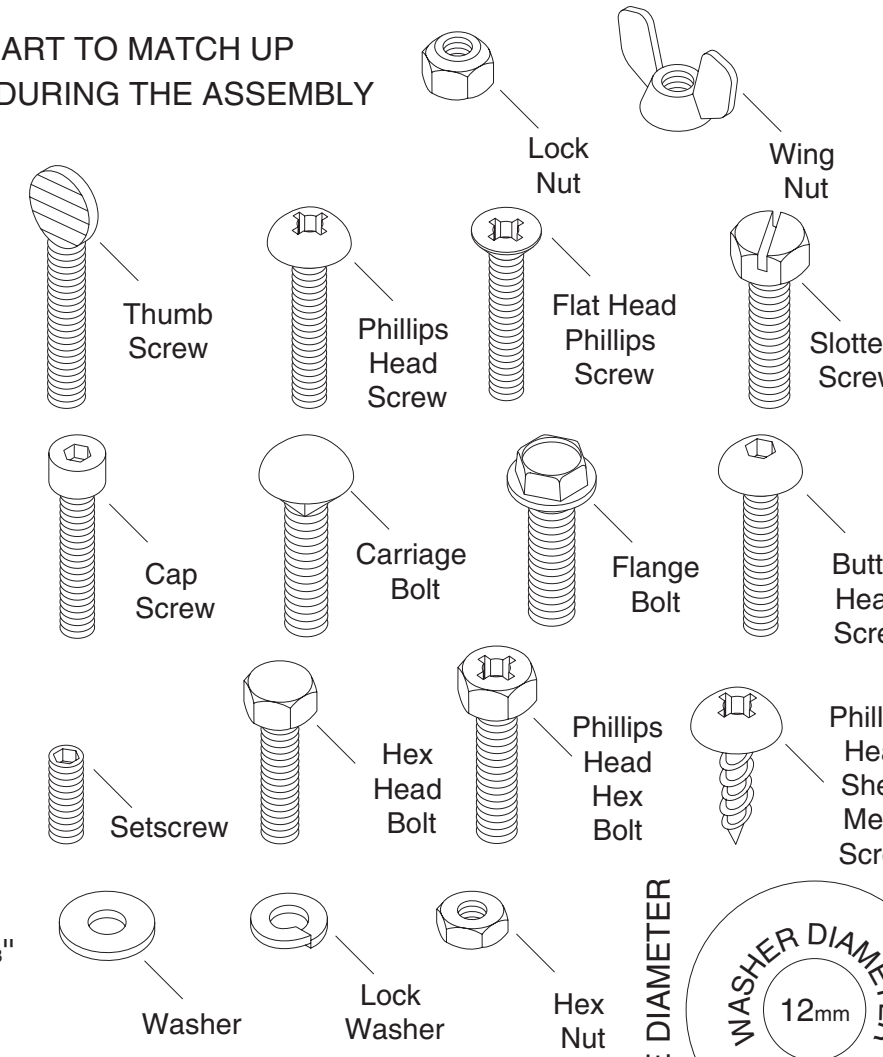

WASHERS ARE MEASURED BY THE INSIDE DIAMETER

# Clean Up

Metal components are often coated with a wax or oil to prevent rusting during shipment. Clean all coated parts with a solvent cleaner or citrus-based degreaser such as Grizzly's G7895 Degreaser. To clean thoroughly, some parts may need to be removed. **For optimum performance from your machine, make sure you clean all moving parts or sliding contact surfaces that are coated.** Avoid chlorine-based solvents as they may damage painted surfaces should they come in contact.

	<b>⚠️ WARNING</b> Gasoline and petroleum products have low flash points and could explode if used to clean machinery. <b>DO NOT</b> use gasoline or petroleum products to clean the machinery.
--	---

	<b>⚠️ WARNING</b> Smoking near solvents could ignite an explosion or fire and cause serious injury. <b>DO NOT</b> smoke while using solvents.
---	--

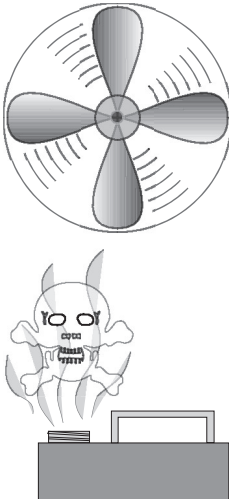
	<b>⚠️ WARNING</b> Lack of ventilation while using solvents could cause serious personal health risks, fire, or environmental hazards. Always work in a well ventilated area to prevent the accumulation of dangerous fumes. Supply the work area with a constant source of fresh air.
---	--



# Site Considerations

## Weight Load

The Model G0528 weighs 125 lbs. Most shop floors should be sufficient to carry the weight of the machine. Reinforce the floor if you question its ability to support the weight.

## Working Clearance

Working clearances can be thought of as the distances between machines and obstacles that allow safe operation of every machine without limitation. Consider existing and anticipated machine needs, size of material to be processed through each machine, and space for auxiliary stands or work tables. Also, consider the relative position of each machine to one another for efficient material handling.

## Lighting And Outlets

Lighting should be bright enough to eliminate shadow and prevent eye strain. Electrical circuits should be dedicated or large enough to handle the amperage draw. Outlets should be located near each machine so power or extension cords are clear of high-traffic areas. Observe local electrical codes for proper installation of new lighting, outlets, or circuits.

	<b>⚠️ WARNING</b> Unsupervised children and visitors inside your shop could receive serious personal injury. Ensure child and visitor safety by keeping all entrances to the shop locked at all times. <b>DO NOT</b> allow unsupervised children or visitors in the shop at any time.
--	--





# Assembly

This section covers the basic assembly and adjustment instructions needed to begin operation. Complete the assembly in the order provided in this manual and then read the remaining portion of the manual before attempting any type of operation.

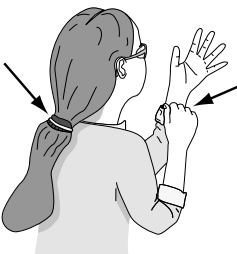
**Your safety is important! Please follow the warnings below during this entire section:**

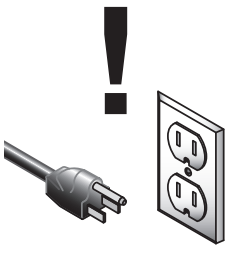
	<p><b>⚠ WARNING</b></p> <p>Loose hair and clothing could get caught in machinery causing serious personal injury. Keep loose clothing rolled up and long hair tied up and away from machinery.</p>
---	--

	<p><b>⚠ WARNING</b></p> <p>Disconnect power to the machine during the entire assembly process. Failure to do this may result in serious personal injury.</p>
---	--

	<p><b>⚠ WARNING</b></p> <p>Projectiles thrown from the machine could cause serious eye injury. Wear safety glasses during assembly.</p>
---	---

	<p><b>⚠ CAUTION</b></p> <p>Sharp edges on metal parts may cause personal injury. Examine the edges of all metal parts before handling.</p>
---	--



# Rubber Feet

Components Needed:	Qty
Rubber Feet .....	4
Phillips Screws 1/4"-20 x 1" .....	4
Hex Nuts 1/4"-20 .....	4
Flat Washers 1/4" .....	4

Tools Needed:	
10mm Wrench or Socket.....	1
Phillips Head Screwdriver .....	1

### To install the rubber feet:

Secure the rubber feet to the stand legs with the Phillips screws, the hex nuts, and the flat washers (Figure 4).

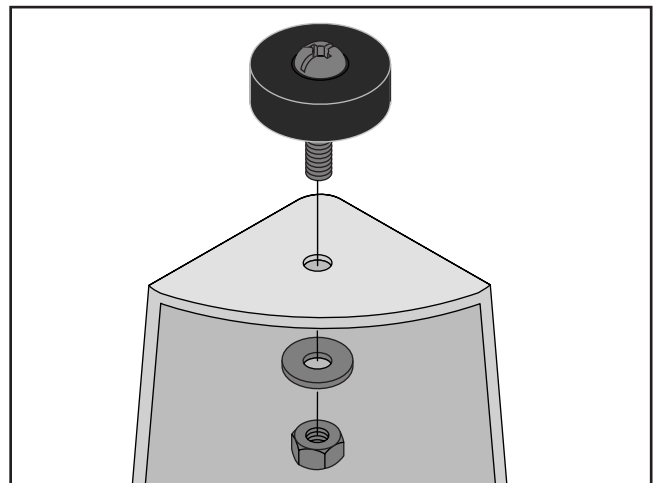

Figure 4. Rubber feet installation.



# Cross Supports

<b>Components Needed:</b>	<b>Qty</b>
Table Assembly .....	1
Table Cross Supports.....	3
Rubber Stops .....	2
Cap Screws $\frac{5}{16}$ "-18 x $1\frac{1}{2}$ " .....	2
Flat Washers $\frac{5}{16}$ " .....	8
Hex Nuts $\frac{5}{16}$ "-18 .....	4
Hex Bolts $\frac{5}{16}$ "-18 x 1" .....	2

<b>Tools Needed:</b>	
12mm Wrench or Socket.....	1
6mm Allen Wrench .....	1

### To attach the table to the stand:

1. Place the table assembly face-down on the floor.
2. Position the table cross supports on the table assembly and align the bolt holes (**Figure 5**).

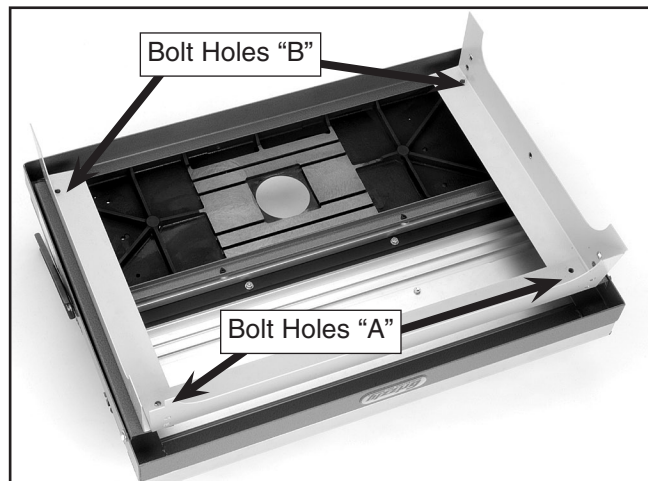

**Figure 5.** Table cross supports.

3. Secure bolt holes "A" (**Figure 5**) with 2 hex bolts, 4 flat washers, and 2 hex nuts.
4. Secure bolts holes "B" (**Figure 5**) with the rubber stops, 2 cap screws, 4 flat washers, and 2 hex nuts (**Figure 6**).

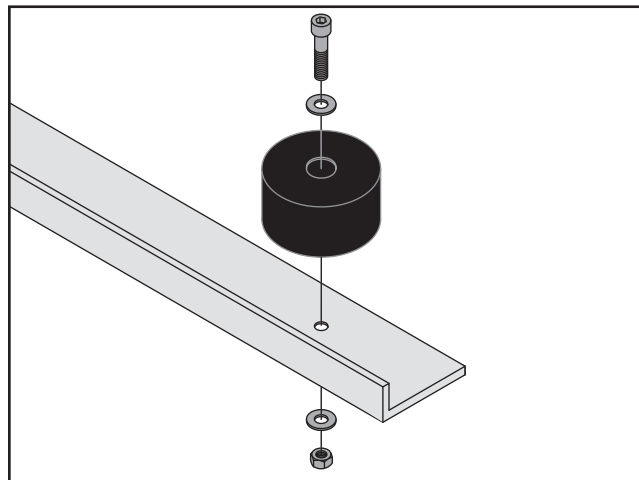

**Figure 6.** Securing cross supports to table.



# Stand

Components Needed:	Qty
Stand Legs .....	4
Diagonal Supports .....	2
Tray .....	1
Carriage Bolts $\frac{5}{16}$ "-18 x $\frac{1}{2}$ " .....	32
Flat Washers $\frac{5}{16}$ " .....	32
Lock Washers $\frac{5}{16}$ " .....	32
Hex Nuts $\frac{5}{16}$ "-18 .....	32

**Tools Needed:**  
12mm Wrench or Socket..... 1

### To assemble the stand:

1. Secure the stand legs to the table cross supports with 12 carriage bolts, 12 flat washers, 12 lock washers, and 12 hex nuts. Note—*The stand leg with the switch cut-out should be facing the front of the machine.*
2. Secure the tray to the stand legs with 16 carriage bolts, 16 flat washers, 16 lock washers, and 16 hex nuts.
3. Secure the diagonal supports (**Figure 7**) to the stand legs and the tray with 4 carriage bolts, 4 flat washers, 4 lock washers, and 4 hex nuts.

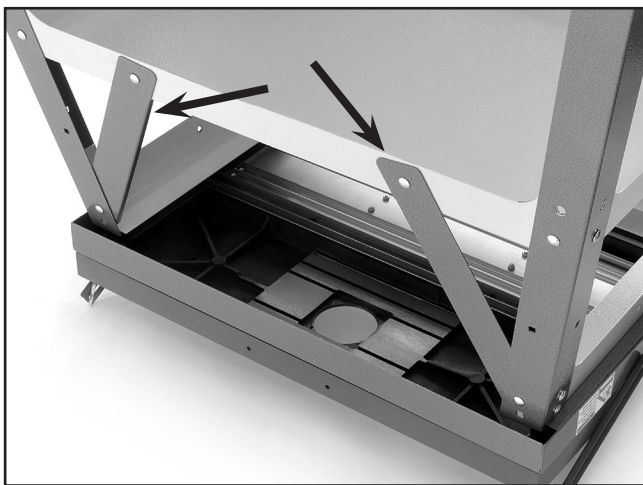

**Figure 7.** Table diagonal support positions.



# Table Braces

Components Needed:	Qty
Spacers .....	2
Phillips Head Screws $\frac{1}{4}$ "-20 x $1\frac{1}{2}$ " .....	2
Flat Washers $\frac{1}{4}$ " .....	4
Hex Nuts $\frac{1}{4}$ "-20 .....	2

**Tools Needed:**  
Phillips Head Screwdriver ..... 1  
Adjustable Wrench ..... 1

## **!WARNING**

Hands and fingers can become seriously injured if they are pinched between the stand edge and the table. **DO NOT** place hands or fingers near the stand edge while the table is in the raised position.

### To assemble the braces:

1. Slide a washer over the screws.
2. Slide the screws through each brace.
3. Thread the screws through the spacers. Note—*Allow just enough of a gap between the washers and the spacers for the table braces to slide freely.*
4. Secure the screw/spacer assemblies to the stand with the washers and the hex nuts.

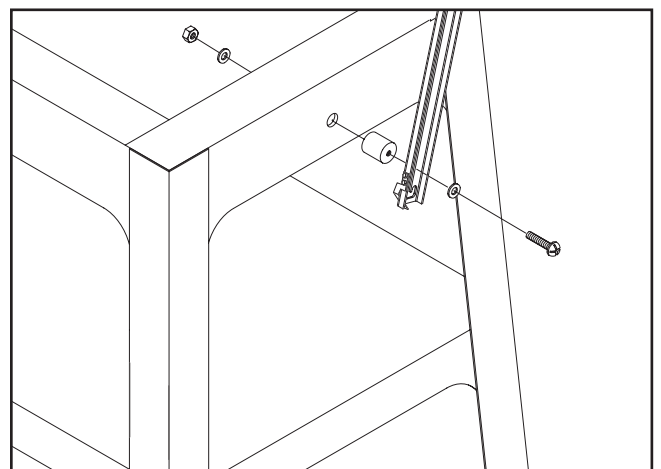

**Figure 8.** Assembling the table braces.



# Fence

Components Needed:	Qty
Left Fence .....	1
Right Fence .....	1
Dust Hood .....	1
Fence Lock Handles.....	2

### Tools Needed:

10mm Wrench or Socket.....	1
11mm Wrench or Socket.....	1

### To attach the fence assembly:

1. Secure the left and right fence assemblies to the table with the fence lock handles. *Note—Use the holes located closest to the edge of the cast iron table.*
2. Secure the dust hood to the top of each fence assembly (**Figure 9**).

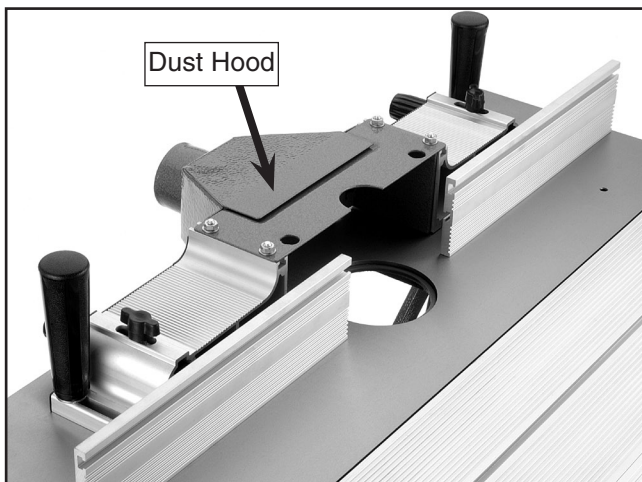

**Figure 9.** Installed fence and dust hood.



# Hold-Downs

Components Needed:	Qty
Workpiece Hold-Down Assemblies .....	2

### Tools Needed:

19mm Wrench .....	1
-------------------	---

### To attach the hold-downs:

1. Remove one of the hex bolts from each of the hold-down brackets.
2. Slide the hold-down brackets through the mounting holes on the dust cover and secure them from the underside of the dust cover with the hex nuts removed in **step 1**.
3. Tighten the hex nuts until the hold-down brackets are secure.
4. Secure the hold-down finders to the hold-down brackets by tightening the threaded star knob (**Figure 10**). *Note—Do not worry about precise placement of the hold-down brackets or fingers at this time.*

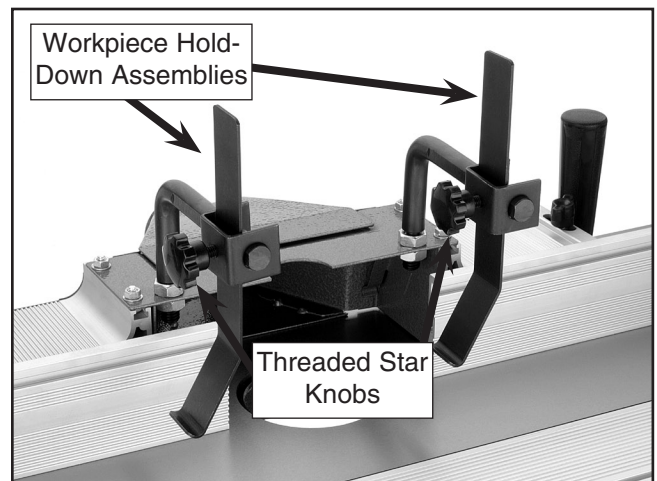

**Figure 10.** Installed hold-down assemblies.





# Miter

Components Needed:	Qty
Miter Fence .....	1
Miter Plate .....	1

## To attach the sliding table:

1. Secure the miter plate to the sliding table by sliding the T-bolts into the table T-track.
2. Position the miter plate in the desired position and tighten the threaded star knobs. Note—Do not worry about precise placement of the of the miter plate at this time.
3. Secure the miter fence to the miter plate with the threaded star knobs (**Figure 11**).

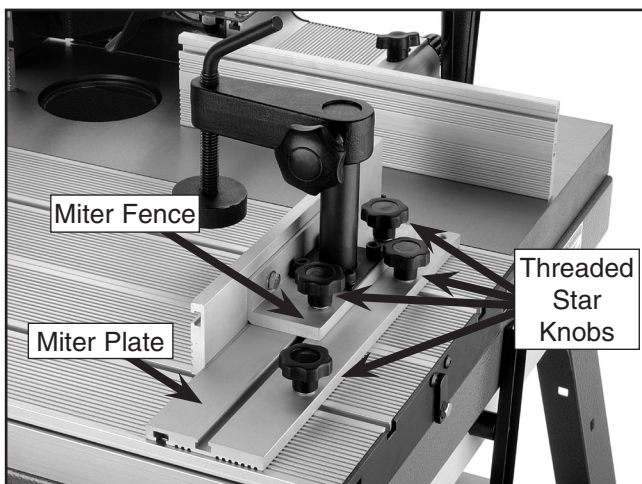

**Figure 11.** Installed sliding table fence.



# Router To Table

Components Needed:	Qty
Router Clamps .....	4

## Tools Needed:

10mm Wrench .....	1
14mm Wrench .....	1

## To attach the router to the table:

1. Lift the table assembly up and engage the table braces on each side. Note—Ensure that the table brace lock tabs are engaged completely around the lock screws (**Figure 12**).

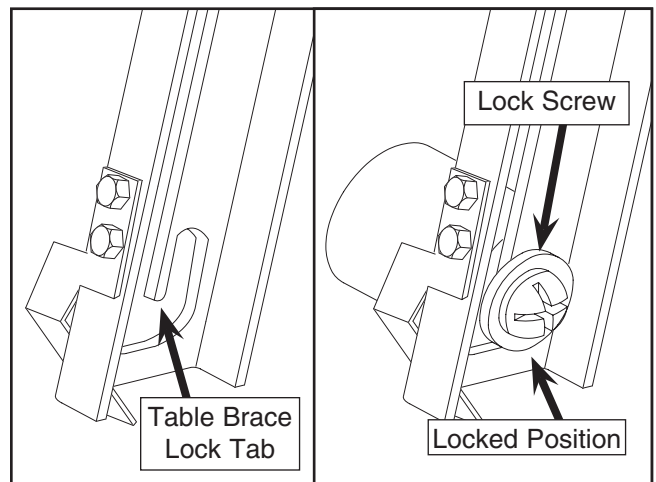

**Figure 12.** Locked table brace.

2. Slide each of the four router clamps into the T-slots on the underside of the cast iron table (**Figure 13**).

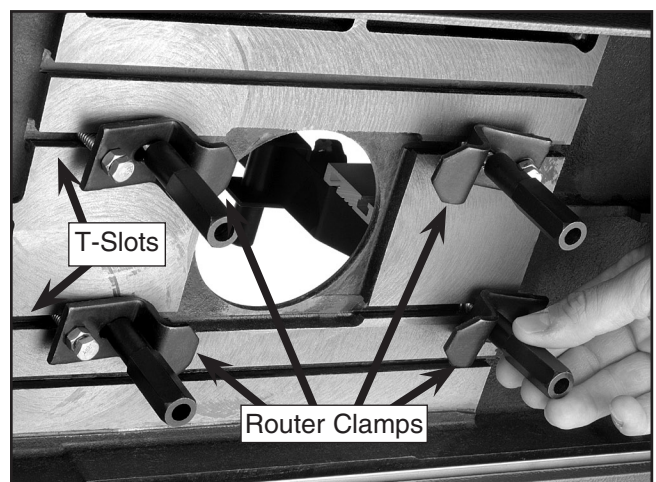

**Figure 13.** Installing the router clamps

3. Loosen the router clamps enough to allow the base of the router to press flat against the underside of the cast iron table. Note—*The router spindle should be centered under the cut out in the cast iron table.*
4. Adjust the thickness bolts and the jam nuts on each of the router clamps to allow the router base to be secured against the table (**Figure 14**).

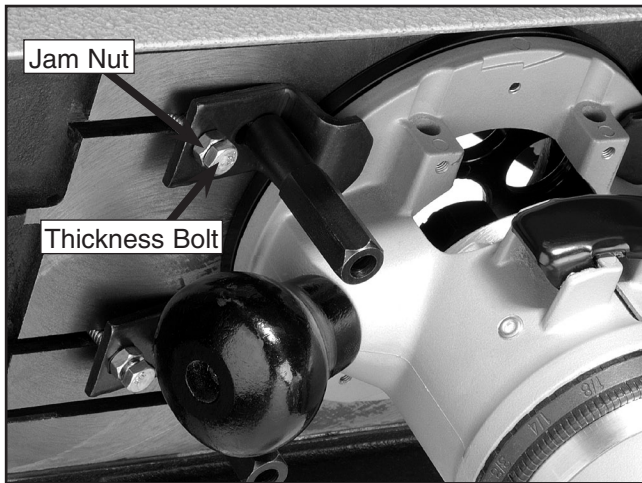

**Figure 14.** Adjust the router clamp thickness bolts.

5. Tighten the router clamps to secure the router base into position.



# Switch

<b>Components Needed:</b>	<b>Qty</b>
Switch .....	1
Switch Box.....	1
Power Cord .....	1
Strain Relief.....	1

<b>Tools Needed:</b>	
Phillips Head Screwdriver .....	1
Adjustable Wrench .....	1

## To attach the switch to the stand leg:

1. Install the strain relief on the outside of the switch, using the plastic nut from the inside to secure the strain relief to the switch box.
2. Feed the power wires through the strain relief and tighten the strain relief screw against the main cord jacket.
3. Secure the green ground wires from the power cord and the switch box to the stand leg, using the Phillips head screw and hex nut already installed in the frame.
4. Push the switch through the cut-out on the stand leg.

5. Attach the black and white power wires to the back of the switch (**Figure 15**), at the clips labeled "B" and "W."

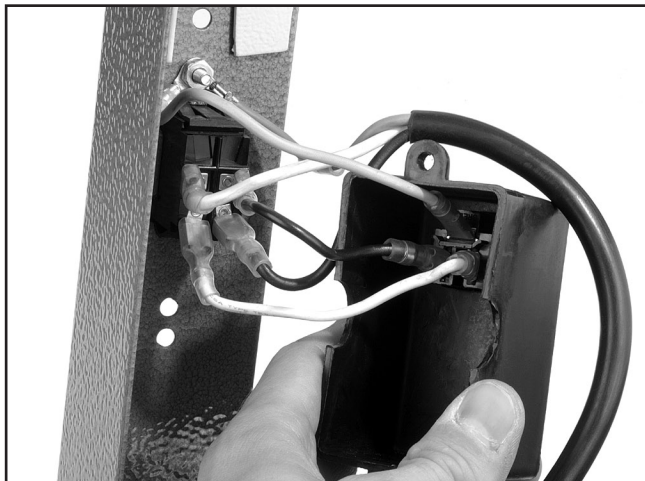

**Figure 15.** Securing the power wires to the switch.

6. Secure the switch box to the back of the switch using the Phillips head screws, the external toothed washers, and the hex nuts already installed in the frame.



## Dust Port Hook-Up

---

---

DO NOT use the router table without adequate dust collection. Hook the dust port up to a shop vacuum or dust collection system.



# SECTION 6: OPERATIONS

## Before Routing

Your safety is important! Please follow the warnings below during this entire section:

### **!WARNING**

To avoid serious personal injury, read and become familiar with the entire instruction manual before using the Model G0528.

### **!WARNING**

Damage to your eyes, lungs, and ears could result from failure to wear safety glasses, a respirator, and hearing protection while using this machine.

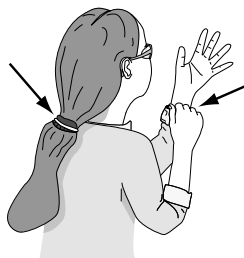
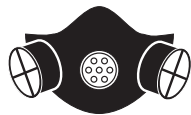

### **!WARNING**

Loose hair and clothing could get caught in machinery and cause serious personal injury. Keep loose clothing rolled up and long hair tied up and away from machinery.



## Routing

Routing operations on your Model G0528 are grouped into three main techniques:

- Jointing an edge (**page 18**)
- Groove cutting (**page 19**)
- Profile cutting (**page 19**)

### Jointing an edge:

Jointing the edge of a board involves using a straight cutting router bit to remove wood from the edge face of a board. The result is a perfectly flat and square edge.

1. Secure a straight cutting router bit into your router according to the router manufacturer's instructions.
2. Snap the smallest table insert into the recessed hole that still allows the router bit to freely rotate.
3. Adjust the outfeed fence even with the left edge of the router bit (**Figure 16**).

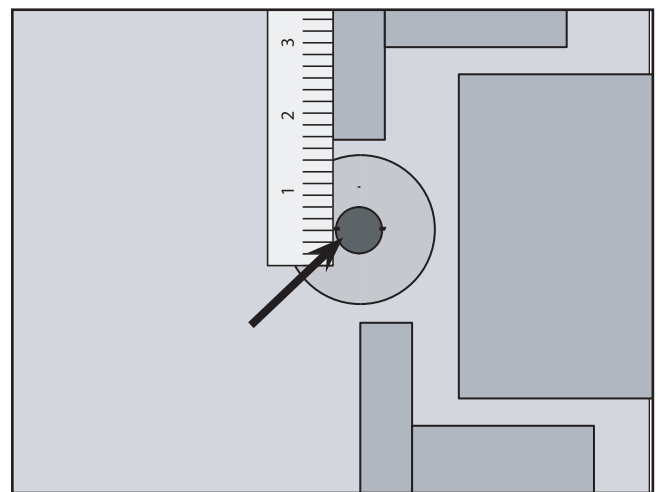

**Figure 16.** Jointing setup.  
(Top View)

4. Raise the bit to a height slightly higher than that of the board thickness.
5. Adjust the infeed fence to the right of the outfeed fence, so that the distance is equal to the desired depth of cut (**Figure 17**).

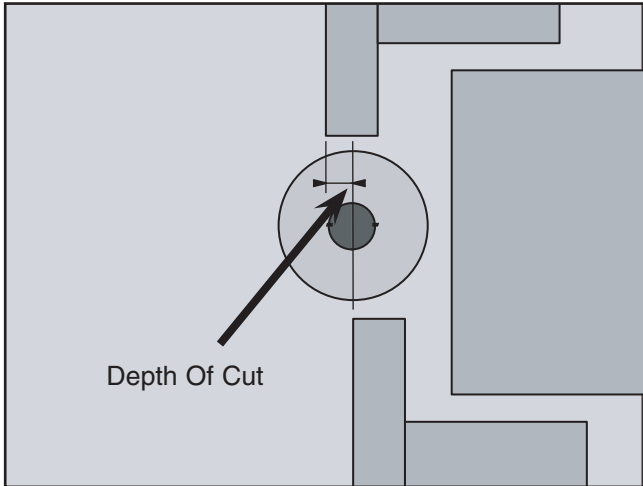
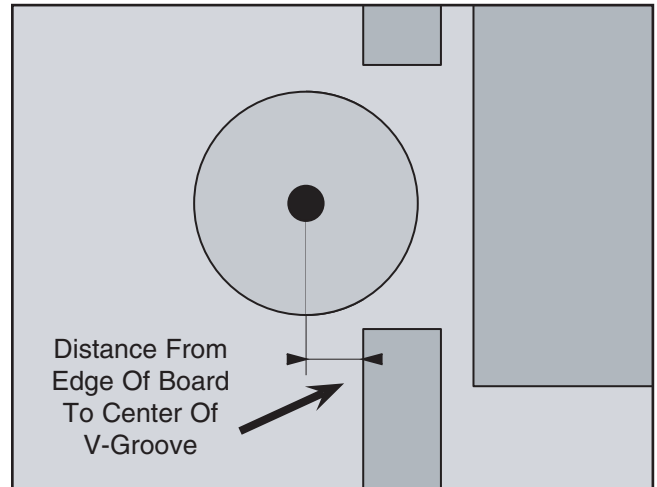

**Figure 17.** Jointing setup.  
(Top View)

#### Groove cutting:

Beading is commonly defined as cutting a groove or bead in the face of a board.

1. Mount a router bit into your router according to the router manufacturer's instructions.
2. Snap the smallest table insert into the recessed hole that still allows the router bit to freely rotate.
3. Raise the router bit to the desired height.
4. Adjust the main fence until the center of the V-groove bit is the desired distance away as shown in **Figure 18 & 19**.



**Figure 18.** Groove cutting setup.  
(Top View)

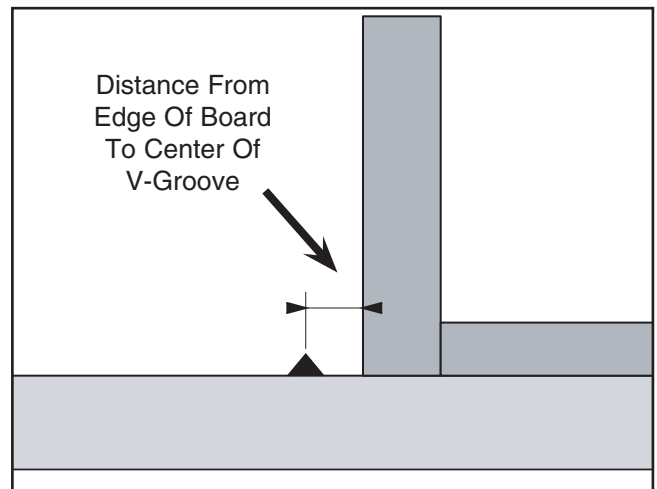

**Figure 19.** Groove cutting setup.  
(Side View)

#### Profile cutting:

Profile cutting is usually performed using a bit with a ball bearing. The ball bearing is used to control the depth of cut into the edge face of a board. A good example would be a chamfer cut. The bearing rides along the uncut edge of the board while the cutter removes the wood.

1. Mount a router bit into your router according to the router manufacturer's instructions.
2. Snap the smallest table insert into the recessed hole that still allows the router bit to freely rotate.

3. Raise the router bit to the desired height.
4. Adjust the fence back and away from the bit only enough to allow the ball bearing to control the depth of cut as shown in **Figures 20 & 21**.
5. Adjust the fence as close as possible to the bearing. The fence will serve as a back-up support, reducing the chance of an accident.

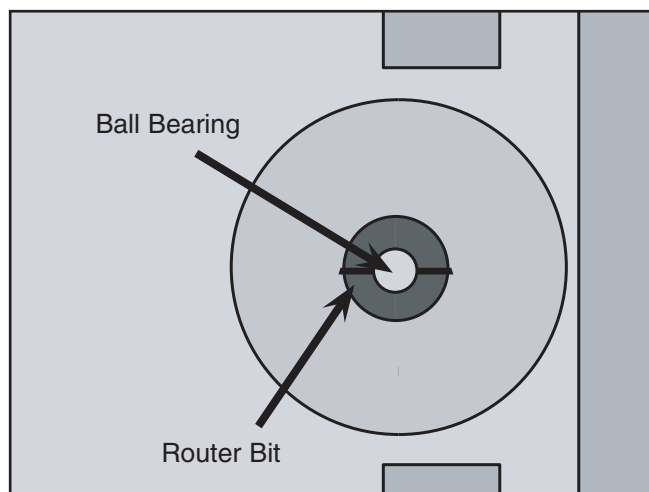

**Figure 20.** Proper setup for profile cutting.  
(Top View)

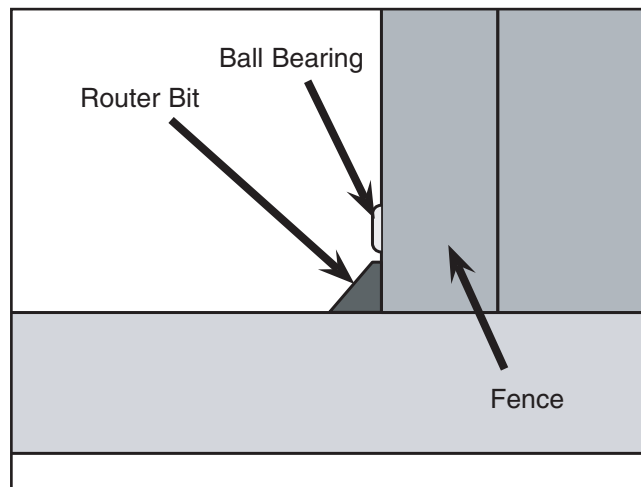

**Figure 21.** Proper setup for profile cutting.  
(Side View)



# SECTION 7: REFERENCE INFO

---

If you need parts or help in assembling your machine, or if you need operational information, call the Grizzly Service Department. Trained service technicians will be glad to help you.

If you have any comments regarding this manual, please write to Grizzly at the address below:

Grizzly Industrial, Inc.  
c/o Technical Documentation  
P.O. Box 2069  
Bellingham, WA 98227-2069

Important safety measures that are essential to the operation of this machine have been explained in *Section 1: Safety*. While most safety measures are generally universal, Grizzly reminds you that each workshop is different and safety rules should be considered as they apply to your specific situation.

We recommend you keep a copy of our current catalog for complete information regarding Grizzly's warranty and return policy. If you need additional technical information relating to this machine, or if you need general assistance or replacement parts, please contact the Service Department at the location listed below.

Grizzly Industrial, Inc.  
1203 Lycoming Circle  
Muncy, PA 17756  
Phone: (570) 546-9663  
Fax: (800) 438-5901  
E-Mail: [techsupport@grizzly.com](mailto:techsupport@grizzly.com)  
Web Site: <http://www.grizzly.com>.

Additional information sources are necessary to realize the full potential of this machine. Trade journals, woodworking magazines, and your local library are good places to start.



# MACHINE DATA SHEET

Customer Service #: (570) 546-9663 • To Order Call: (800) 523-4777 • Fax #: (800) 438-5901

## MODEL G0528 ROUTER TABLE

Design Type ..... Floor Model

### Overall Dimensions:

Main Table ..... 31" W x 10" D x 1<sup>3</sup>/<sub>4</sub>" T  
 Sliding Table ..... 31" W x 12" D  
 Total Table Surface..... 31" W x 22" D  
 Overall Height ..... 42" H  
 Height From Table To Floor..... 34" H  
 Overall Width..... 40"W  
 Overall Length..... 30" D  
 Shipping Weight..... 132 lbs.  
 Net Machine Weight..... 125 lbs.  
 Box Size ..... 35<sup>1</sup>/<sub>2</sub>" W x 26" D x 8" H  
 Footprint ..... 40" W x 30" D

### Capacities:

Suitable Routers For Mounting ..... <sup>3</sup>/<sub>4</sub> HP - 5 HP  
 Table Counterbore ..... 3<sup>1</sup>/<sub>2</sub>"  
 Table Insert Diameters..... 1<sup>1</sup>/<sub>8</sub>" & 2<sup>5</sup>/<sub>16</sub>"  
 Fence Size ..... 3" x 12" (Each Piece)  
 Maximum Fence Working Surface..... 3" x 36"  
 Dust Port ..... 2<sup>1</sup>/<sub>2</sub>"

### Construction:

Main Table ..... Precision-Ground Cast Iron  
 Sliding Table ..... Aluminum  
 Fence Assembly..... Aluminum & Steel  
 Stand..... Powder-Coated Steel  
 Miter Body ..... Aluminum

### Features:

..... Workpiece Hold-Downs  
 ..... Clamping Miter Gauge  
 ..... Toggle Switch W/Safety Key  
 ..... Dual Power Outlets For Convenient Router/Accessory Plug-Ins  
 ..... 45° Table Tilt For Easy Router Mounting  
 ..... Sliding Table

*Specifications, while deemed accurate, are not guaranteed.  
8/2003*



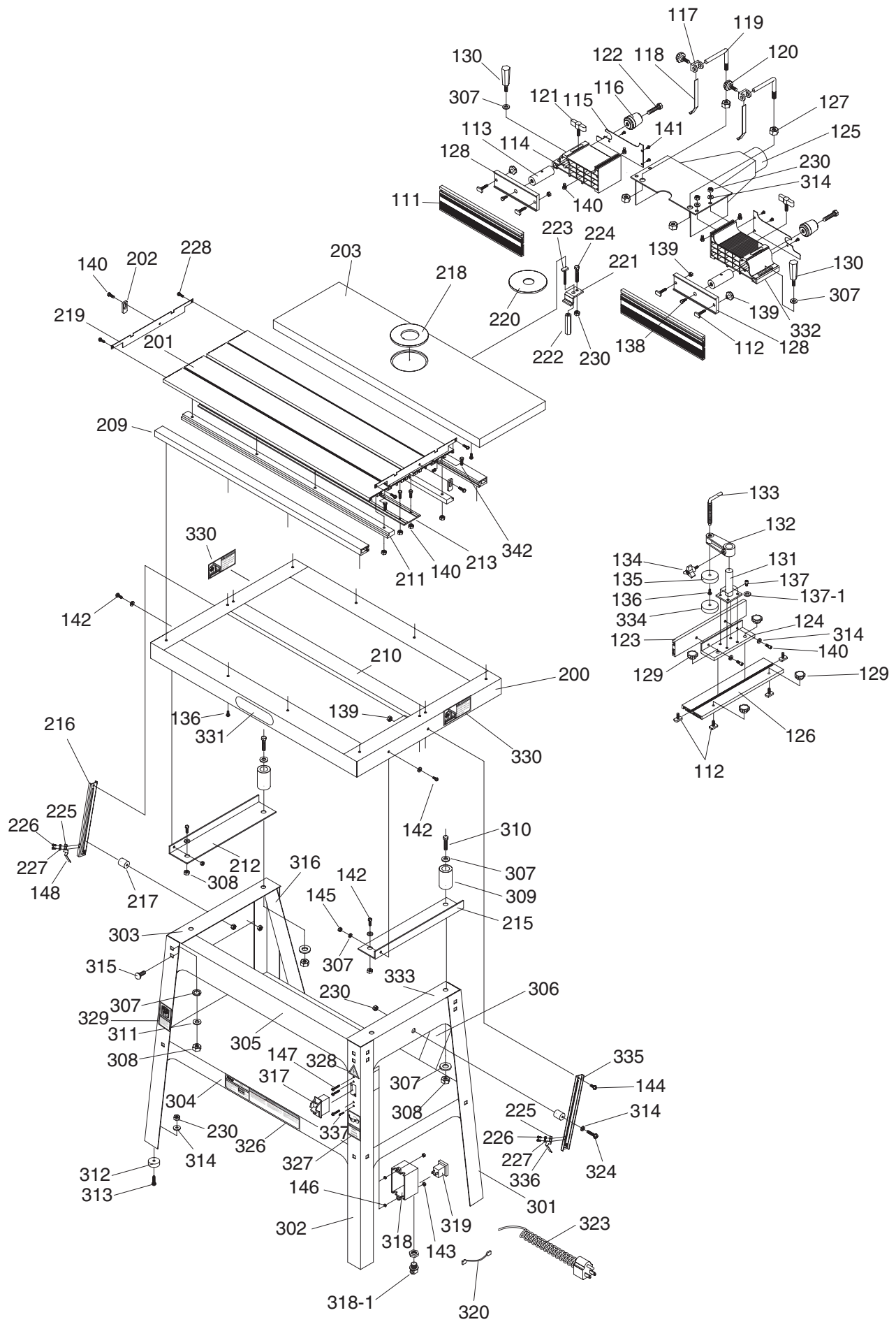

REF	PART #	DESCRIPTION
111	P0528111	FENCE HALF
112	P0528112	T-BOLT 1/4-20 X 3/4"
113	P0528113	MICRO-ADJUSTMENT ROD
114	P0528114	FENCE BODY (LEFT)
115	P0528115	FENCE BODY GUARD
116	P0528116	MICRO-ADJUSTMENT NUT
117	P0528117	HOLD-DOWN BRACKET
118	P0528118	HOLD-DOWN
119	P0528119	L-BRACKET
120	P0528120	KNOB BOLT 5/16-18 X 5/8"
121	P0528121	HANDLE BOLT 3/8-16 X 3/4"
122	PB16	HEX BOLT 3/8-16 X 1-1/2"
123	P0528111	FENCE PLATE
124	P0528112	CLAMP HOLDER
125	P0528113	DUST HOOD
126	P0528114	SHORT FENCE
127	PN34	HEX NUT 1/2-12
128	P0528128	CLAMP PLATE
130	P0528130	HEAVY HANDLE
131	P0528131	CLAMP BRACKET
132	P0528132	BRACKET
133	P0528133	CLAMP ROD
134	P0528134	HANDLE BOLT 1/4-20 X 5/8"
135	P0528135	CLAMP PLATE
136	PS06	PHLP HD SCR 10-24 X 3/8"

REF	PART #	DESCRIPTION
137	PSB04	CAP SCREW 1/4-20 X 1/2"
137-1	PLW02	LOCK WASHER 1/4"
138	PB18	HEX BOLT 3/8-16 X 1"
139	PLN02	LOCK NUT 1/4-20
140	PB19	HEX BOLT 1/4-20 X 1/2"
141	PS06	PHLP HD SCR 10-24 X 3/8"
142	PB03	HEX BOLT 5/16-18 X 1"
143	PN07	HEX NUT 10-24
145	PLN03	LOCK NUT 5/16"-18
146	PTLW01	EXT TOOTH WASHER #10
147	PS08	PHLP HD SCR 10-24 X 3/4"
148	P0528148	LOCK PRESSURE PLATE
200	P0528200	TABLE FRAME
201	P0528201	SLIDING TABLE
202	P0528202	UPPER PLATE
203	P0528203	FIXED TABLE
209	P0528209	SLIDEWAY
210	P0528210	MIDDLE BRACKET
211	P0528211	SLIDE RAIL
212	P0528212	TABLE RIGHT SUPPORT
213	P0528213	FIX PIECE
215	P0528215	TABLE LEFT SUPPORT
216	P0528216	45° POSITIONER (LEFT)
217	P0528217	SPACER
218	P0528218	60MM INSERT PLATE

REF	PART #	DESCRIPTION
219	P0528219	GUARD
220	P0528220	29MM INSERT PLATE
221	P0528221	MOTOR CLAMP PIECE
222	P0528222	HEX CLAMP SHAFT
223	P0528223	T-BOLT 1/4-20 X 2"
224	PB26	HEX BOLT 1/4-20 X 1-1/2"
226	PS38M	PHLP HD SCR M4-0.7 X 10
227	PS38M	PHLP HD SCR M4-.7 X 10
228	PHTEK26	TAP SCREW #10 X 1/2"
229	PB19	HEX BOLT 1/4-20 X 1/2"
230	PN05	HEX NUT 1/4-20
301	P0528301	FLOOR STAND
302	P0528302	FRONT STAND (WITH SWITCH)
303	P0528303	UPPER ANGLE PLATE (LEFT)
304	P0528304	MIDDLE PLATE
305	P0528305	FRONT UPPER ANGLE PLATE
306	P0528306	RIGHT BRACKET
307	PW07	FLAT WASHER 5/16"
308	PN02	HEX NUT 5/16-18
309	P0528309	RUBBER STOP
310	PSB11	CAP SCREW 5/16-18 X 1-1/4
311	PLW01	LOCK WASHER 5/16
312	P0528312	PAD
313	PS19	PHLP HD SCR 1/4-20 X 1"

REF	PART #	DESCRIPTION
314	PW06	FLAT WASHER 1/4"
315	PCB01	CARRIAGE BOLT 5/16-18 X 5/8"
316	P0528316	LEFT BRACKET
317	P0528317	SWITCH
318	P0528318	SWITCH BOX
318-1	P0528318-1	STRAIN RELIEF
319	P0528319	KEY SOCKET
320	P0528320	BLACK WIRE
321	P0528321	WHITE WIRE
322	P0528322	GROUND WIRE
323	P0528323	POWER WIRE
324	PS14	PHLP HD SCR 1/4-20 X 1-1/2"
326	P0528326	MACHINE ID/WARNING LABEL
327	PLABEL-11	SAFETY GLASSES LABEL
328	PLABEL-14	ELECTRICITY LABEL
329	PLABEL-12	READ MANUAL LABEL
330	P0528330	PINCH FINGERS LABEL
331	P0528331	GRIZZLY LABEL
332	P0528332	FENCE BODY (RIGHT)
333	P0528333	UPPER ANGLE PLATE (RIGHT)
334	P0528334	RUBBER PLATE
335	P0528335	45° POSITIONER (RIGHT)
342	P0528342	T-BOLT 1/4-20 X 1"

# Warranty & Returns

---

Grizzly Industrial, Inc. warrants every product it sells for a period of 1 year to the original purchaser from the date of purchase. This warranty does not apply to defects due directly or indirectly to misuse, abuse, negligence, accidents, repairs or alterations or lack of maintenance. This is Grizzly's sole written warranty and any and all warranties that may be implied by law, including any merchantability or fitness, for any particular purpose, are hereby limited to the duration of this written warranty. We do not warrant or represent that the merchandise complies with the provisions of any law or acts unless the manufacturer so warrants. In no event shall Grizzly's liability under this warranty exceed the purchase price paid for the product and any legal actions brought against Grizzly shall be tried in the State of Washington, County of Whatcom.

We shall in no event be liable for death, injuries to persons or property or for incidental, contingent, special, or consequential damages arising from the use of our products.

To take advantage of this warranty, contact us by mail or phone and give us all the details. We will then issue you a "Return Number," which must be clearly posted on the outside as well as the inside of the carton. We will not accept any item back without this number. Proof of purchase must accompany the merchandise.

The manufacturers reserve the right to change specifications at any time because they constantly strive to achieve better quality equipment. We make every effort to ensure that our products meet high quality and durability standards and we hope you never need to use this warranty.

Please feel free to write or call us if you have any questions about the machine or the manual.

Thank you again for your business and continued support. We hope to serve you again soon.

# WARRANTY CARD

Name \_\_\_\_\_  
Street \_\_\_\_\_  
City \_\_\_\_\_ State \_\_\_\_\_ Zip \_\_\_\_\_  
Phone Number \_\_\_\_\_ E-Mail \_\_\_\_\_ FAX \_\_\_\_\_  
MODEL # \_\_\_\_\_ Serial # \_\_\_\_\_ Order # \_\_\_\_\_

The following information is given on a voluntary basis. It will be used for marketing purposes to help us develop better products and services. Of course, all information is strictly confidential.

1. How did you learn about us? \_\_\_\_\_ Other \_\_\_\_\_  
 Advertisement  Friend  
 Catalog  Card Deck  
 World Wide Web  
\_\_\_\_\_  
 Other \_\_\_\_\_
2. Which of the following magazines do you subscribe to.  
 American Woodworker  Practical Homeowner  
 Cabinetmaker  Shop Notes  
 Family Handyman  Today's Homeowner  
 Fine Homebuilding  WOOD  
 Fine Woodworking  Wooden Boat  
 Home Handyman  Woodshop News  
 Journal of Light Construction  Woodsmith  
 Old House Journal  Woodwork  
 Popular Mechanics  Woodworker  
 Popular Science  Woodworker's Journal  
 Popular Woodworking  Workbench  
\_\_\_\_\_  
 Other \_\_\_\_\_
3. Which of the following woodworking/remodeling shows do you watch?  
 Backyard America  The New Yankee Workshop  
 Home Time  This Old House  
 The American Woodworker  Woodwright's Shop  
\_\_\_\_\_  
 Other \_\_\_\_\_
4. What is your annual household income?  
 \$20,000-\$29,999  \$60,000-\$69,999  
 \$30,000-\$39,999  \$70,000-\$79,999  
 \$40,000-\$49,999  \$80,000-\$89,999  
 \$50,000-\$59,999  \$90,000 +
5. What is your age group?  
 20-29  50-59  
 30-39  60-69  
 40-49  70 +
6. How long have you been a woodworker?  
 0 - 2 Years  8 - 20 Years  
 2 - 8 Years  20+ Years
7. How would you rank your woodworking skills?  
 Simple  Advanced  
 Intermediate  Master Craftsman
8. What stationary woodworking tools do you own? Check all that apply.  
 Air Compressor  Panel Saw  
 Bandsaw  Planer  
 Drill Press  Power Feeder  
 Drum Sander  Radial Arm Saw  
 Dust Collector  Shaper  
 Horizontal Boring Machine  Spindle Sander  
 Jointer  Table Saw  
 Lathe  Vacuum Veneer Press  
 Mortiser  Wide Belt Sander
9. How many of your woodworking machines are Grizzly? \_\_\_\_\_
10. Which benchtop tools do you own? Check all that apply.  
 1" x 42" Belt Sander  6" - 8" Grinder  
 5" - 8" Drill Press  Mini Lathe  
 8" Table Saw  10" - 12" Thickness Planer  
 8" - 10" Bandsaw  Scroll Saw  
 Disc/Belt Sander  Spindle/Belt Sander  
 Mini Jointer  
\_\_\_\_\_  
 Other \_\_\_\_\_
11. How many of the machines checked above are Grizzly? \_\_\_\_\_
12. Which portable/hand held power tools do you own? Check all that apply.  
 Belt Sander  Orbital Sander  
 Biscuit Joiner  Palm Sander  
 Circular Saw  Portable Planer  
 Detail Sander  Saber Saw  
 Drill/Driver  Reciprocating Saw  
 Miter Saw  Router  
\_\_\_\_\_  
 Other \_\_\_\_\_
13. What machines/supplies would you like Grizzly Industrial to carry?  
\_\_\_\_\_  
\_\_\_\_\_
14. What new accessories would you like Grizzly Industrial to carry?  
\_\_\_\_\_  
\_\_\_\_\_
15. What other companies do you purchase your tools and supplies from?  
\_\_\_\_\_  
\_\_\_\_\_
16. Do you think your purchase represents good value?  
 Yes  No
17. Would you recommend Grizzly Industrial to a friend?  
 Yes  No
18. Would you allow us to use your name as a reference for Grizzly customers in your area? **Note: We never use names more than three times.**  
 Yes  No
19. Comments: \_\_\_\_\_

CUT ALONG DOTTED LINE

FOLD ALONG DOTTED LINE

---

---

---



Place  
Stamp  
Here



**GRIZZLY INDUSTRIAL, INC.**  
**P.O. BOX 2069**  
**BELLINGHAM, WA 98227-2069**



FOLD ALONG DOTTED LINE

Send a Grizzly Catalog to a friend:

Name _____
Street _____
City _____ State _____ Zip _____

TAPE ALONG EDGES--PLEASE DO NOT STAPLE



# *grizzly.com*

**TOOL WEBSITE**

Buy Direct and Save with Grizzly® – Trusted, Proven and a Great Value!

*Visit Our Website Today And Discover Why  
Grizzly® Is The Industry Leader!*

- SECURE ORDERING
- ORDERS SHIPPED WITHIN 24 HOURS
- E-MAIL RESPONSE WITHIN ONE HOUR

-OR-

Call Today For A **FREE**  
Full Color Catalog  
**1-800-523-4777**





## Free Manuals Download Website

<http://myh66.com>

<http://usermanuals.us>

<http://www.somanuals.com>

<http://www.4manuals.cc>

<http://www.manual-lib.com>

<http://www.404manual.com>

<http://www.luxmanual.com>

<http://aubethermostatmanual.com>

Golf course search by state

<http://golfingnear.com>

Email search by domain

<http://emailbydomain.com>

Auto manuals search

<http://auto.somanuals.com>

TV manuals search

<http://tv.somanuals.com>