



MODEL T23010 POWER FEED FOR G0704 MILL/DRILL INSTRUCTIONS

For questions or help with this product contact Tech Support at (570) 546-9663 or techsupport@grizzly.com

Specifications

Motor30W 90VDC 0.6A
Table Travel Speed Range0–15³/₄ inch/min

Functional Overview

The Model T23010 Power Feed is designed to install on the left side of the G0704 Mill/Drill table to provide powered longitudinal table movement.

Refer to **Figures 1–2** and the descriptions below to become familiar with the functional parts of the power feed system.

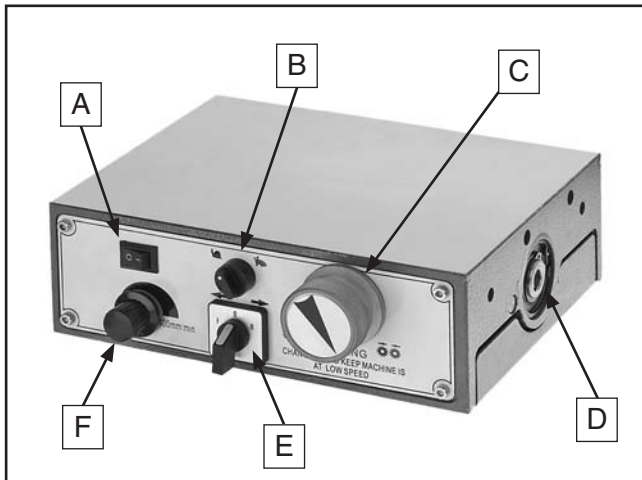

Figure 1. Power feed controls.

- A. ON/OFF Switch.** The main power switch for the power feed.
- B. Rapid Movement Switch.** Moves the table at the maximum speed in the direction selected.
- C. Shift Knob.** Engages/disengages power feed gears. Engage to use the power feed, disengage to use the hand wheel.

- D. Leadscrew Connector.** Connects the power feed to the table leadscrew.
- E. Direction Switch.** Starts, reverses, and stops longitudinal table movement.
- F. Speed Dial.** Controls the speed of the table movement (turn the dial clockwise to increase the speed).

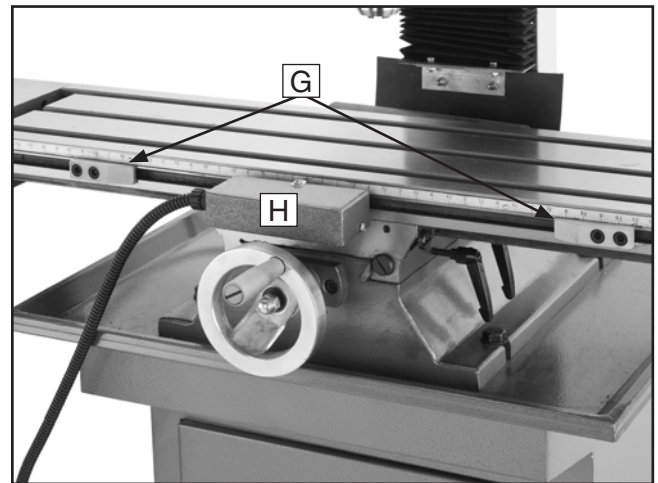

Figure 2. Limit switch and stops.

- G. Limit Stops.** Activate the limit switch. Secure these devices along the table to set the range of movement.
- H. Limit Switch.** Stops powered table movement when either limit stop presses a switch plunger. To reset, turn the direction switch to the neutral (middle) position. Use the shift knob to disengage the power feed from the leadscrew. Then, using the handwheel, return the table to the operating range. Resume operation as usual.

COPYRIGHT © APRIL, 2012 BY GRIZZLY INDUSTRIAL, INC.

WARNING: NO PORTION OF THIS MANUAL MAY BE REPRODUCED IN ANY SHAPE OR FORM WITHOUT THE WRITTEN APPROVAL OF GRIZZLY INDUSTRIAL, INC.

#TSKN14902 PRINTED IN CHINA

Installation

Read the entire installation section before you begin these steps. This will help ensure that you understand and are prepared to make the necessary alterations to the mill/drill table.

Tools Needed	Qty
Hex Wrench 5mm.....	1
Hex Wrench 3mm.....	1
Socket Wrench 13mm	1
Hammer.....	1
Punch	1
Drill Bit 3.3mm or #30	1
Tap Drill M4-.7	1
#2 Phillips Screwdriver	1
Wrench 6mm	1

To install the power feed assembly:

1. Using a 13mm socket wrench, remove the left table handwheel, as shown in **Figure 3**.

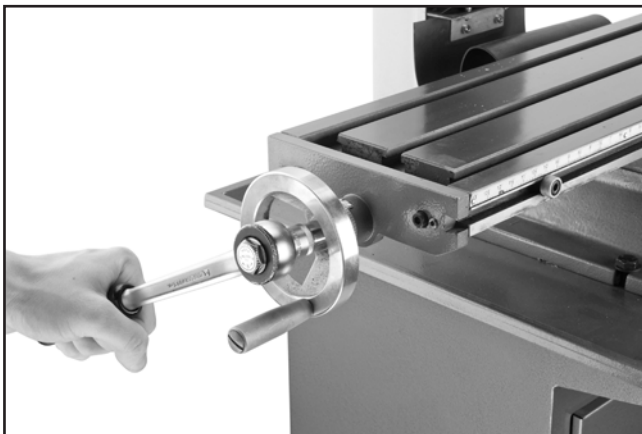

Figure 3. Removing left table handwheel.

2. Carefully remove the 4 x 4 x 12 key from the leadscrew.

3. Remove the (2) M6-1 x 10 cap screws securing the left table end-plate to table, then remove the left table end-plate from the table, as shown in **Figure 4**.

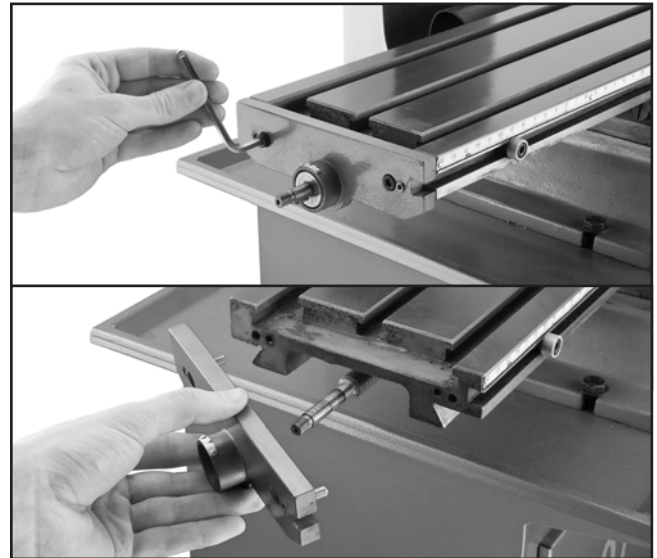

Figure 4. Removing cap screws and end-plate from table.

4. Remove the (6) M4-.7 x 10 cap screws securing the bottom cover, as shown in **Figure 5**, then remove the bottom cover.



Figure 5. Removing bottom cover.

5. Insert the (2) M6-1 T-slot nuts into the table slot.



6. Replace the 4 x 4 x 12 key in the leadscrew, align the keyway and the key, as shown in **Figure 6**, and install the power feed on the table.

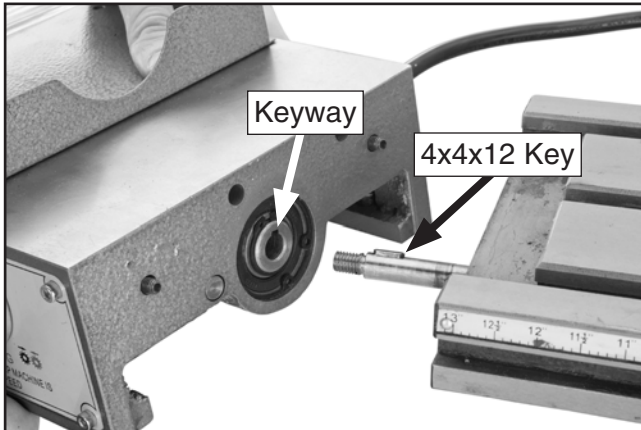

Figure 6. Installing power feed on table.

7. Secure the power feed to the table with (2) M6-1 x 10 cap screws, as shown in **Figure 7**.

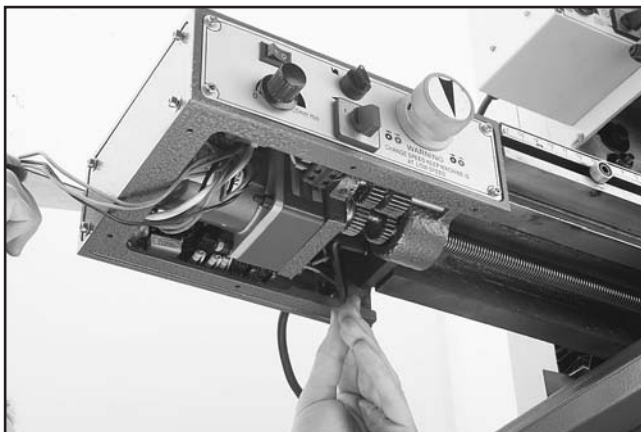

Figure 7. Securing power feed to table.

8. Replace the bottom cover removed in **Step 4**, as shown in **Figure 8**.



Figure 8. Replacing bottom cover.

9. Remove the center stop block, by removing two cap screws, as shown in **Figure 9**.

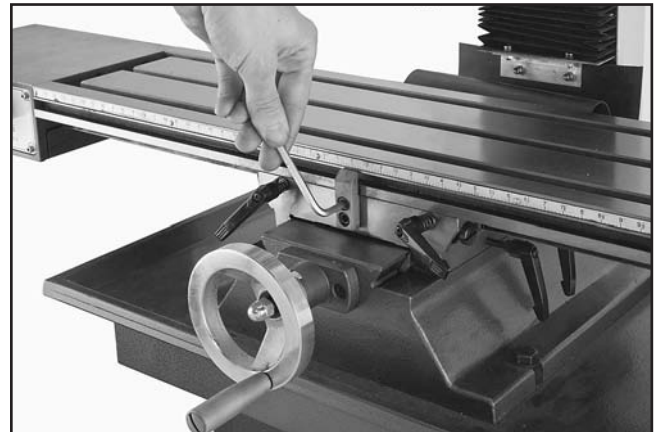

Figure 9. Removing center stop block.

10. Using a #2 Phillips head screwdriver and a 10 wrench, remove the (2) lock levers, as shown in **Figure 10**.



Figure 10. Removing lock levers.

11. Using a 13mm socket wrench, remove the crossfeed table handwheel, as shown in **Figure 11**.

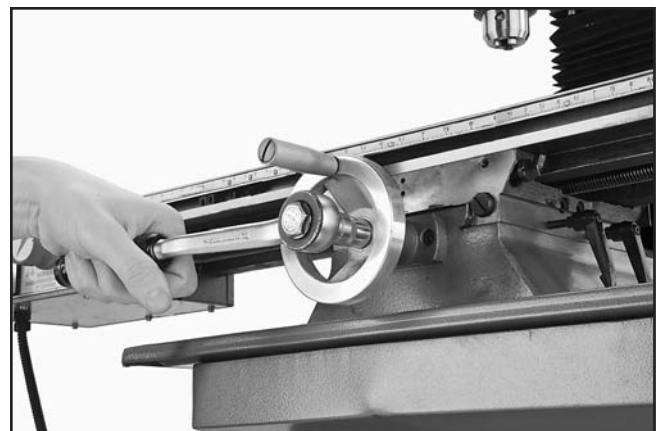

Figure 11. Removing the crossfeed handwheel.



12. Position the limit switch assembly and bracket on the table, and mark the holes with a permanent marker (see **Figure 12**).

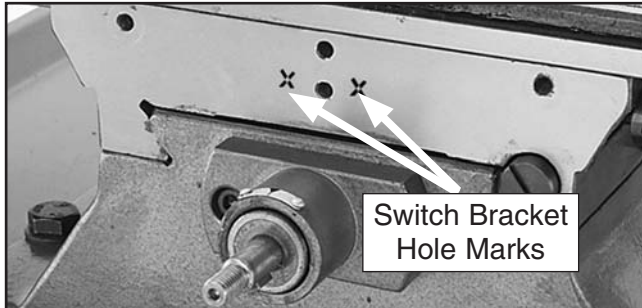

Figure 12. Marks made for switch bracket holes.

13. Using hammer and a punch, center punch the table to mark the hole locations for drilling, as shown in **Figure 13**.



Figure 13. Center punching for drilling.

14. Using a 3.3mm/#30 drill bit, drill two holes for mounting the limit switch assembly, as shown in **Figure 14**.



Figure 14. Drilling holes for limit switch assembly.

15. Using an M4-.7 tap drill, tap the holes drilled in **Step 14**, as shown in **Figure 15**.

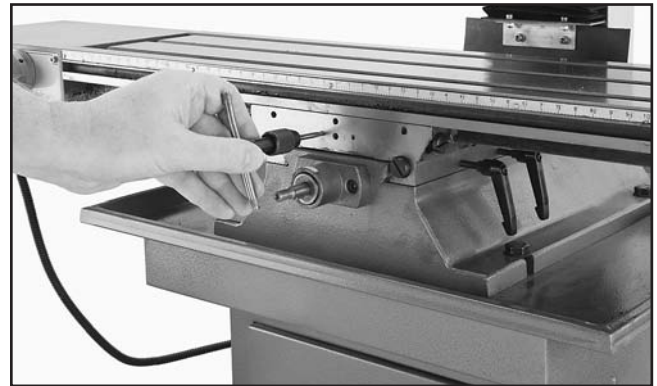

Figure 15. Tapping holes for limit switch assembly.

16. Secure the limit switch assembly to the table with (2) M4-.7 x 8 cap screws, as shown in **Figure 16**.



Figure 16. Attaching the limit switch assembly.

17. Using a 5mm hex wrench, remove the (2) round table stops, as shown in **Figure 17**.

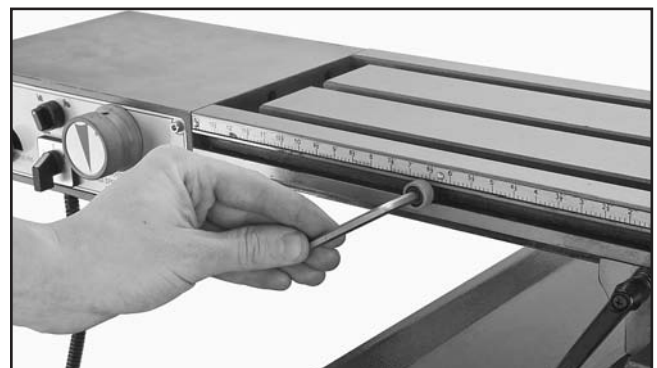

Figure 17. Removing the round table stops.

- Using a 5mm hex wrench, secure the (2) table stops to the (4) T-slot nuts with (4) M6-1 x 10 cap screws, as shown in **Figure 18**.



Figure 18. Attaching the right limit stop.

- Replace the (2) lock levers removed in **Step 11**.
- Replace the crossfeed handwheel removed in **Step 11** (see **Figure 19**). Congratulations, the installation of the power feed is now complete.



Figure 19. Power feed installation complete.

Motor Brush Replacement

The motor brushes in the power feed are the only part of the unit that may need periodic replacing.

Tools Needed

	Qty
Hex Wrench 3mm.....	1
#2 Standard Screwdriver.....	1
New Motor Brushes.....	2

To replace the motor brushes:

- Remove the (4) cap screws, as shown in **Figure 20**, and remove the left cover from the power feed assembly.



Figure 20. Removing left cover cap screws.

- Using a #2 Standard Screwdriver, remove the motor brush covers from the motor housing (see **Figure 21**).

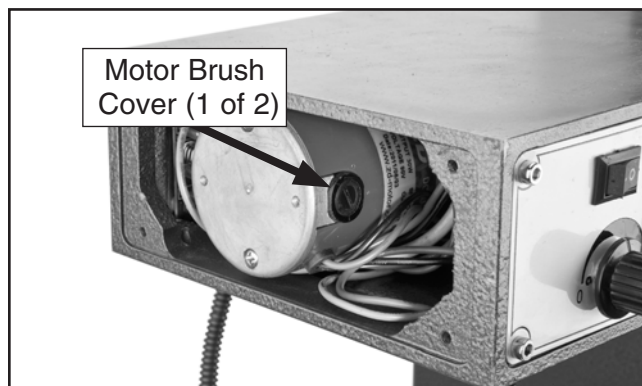

Figure 21. Motor brush cover (1 of 2).

- Remove the used motor brushes and install new motor brushes, as shown in **Figure 22**.



Figure 22. Removing motor brush.

- Replace motor brush covers and left cover removed in **Steps 1-2**.

Wiring Diagram

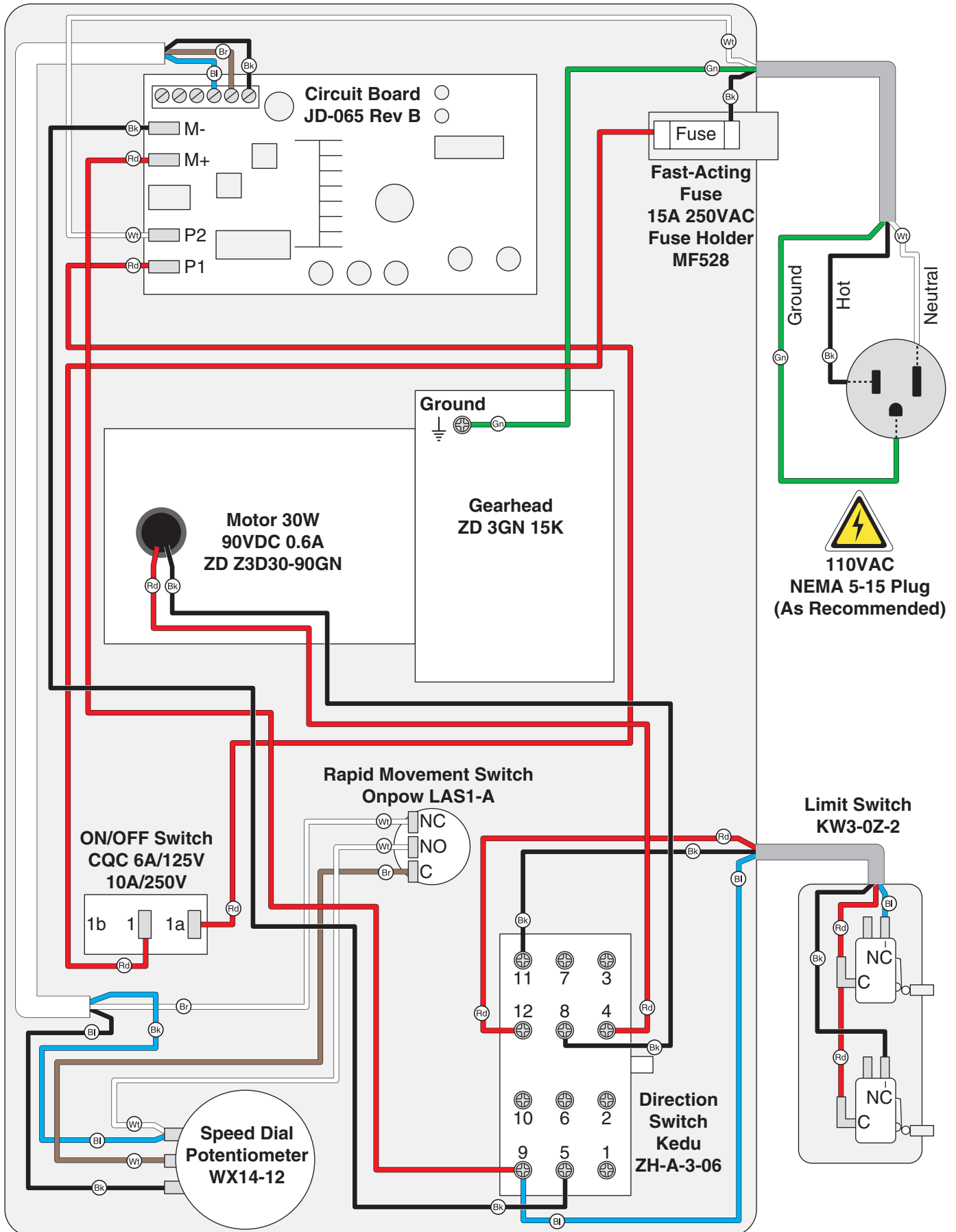

Parts

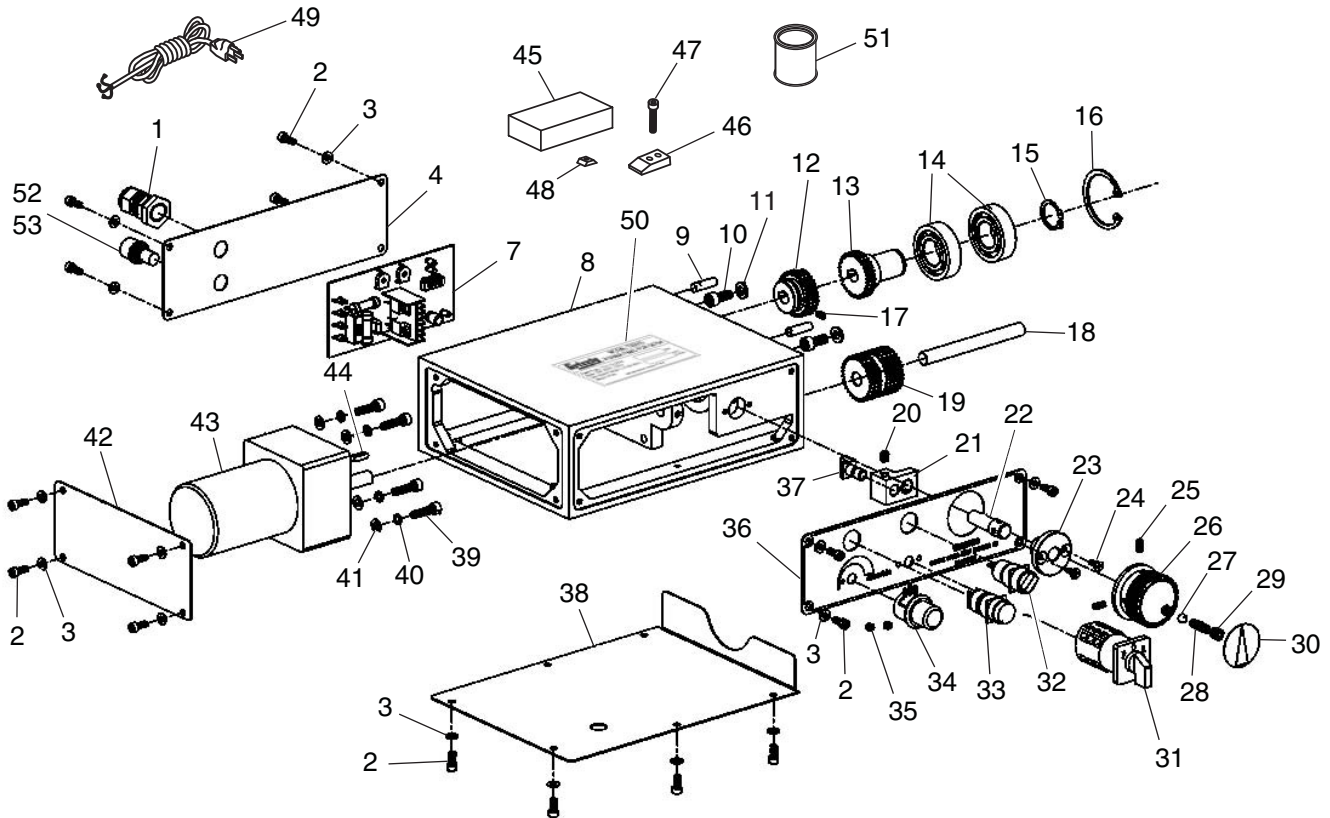

REF	PART #	DESCRIPTION
1	PT23010001	STRAIN RELIEF 1/4" LT, STRAIGHT
2	PCAP17M	CAP SCREW M4-.7 X 10
3	PW05M	FLAT WASHER 4MM
4	PT23010004	BACK COVER
7	PT23010007	CIRCUIT BOARD
8	PT23010008	BODY
9	PT23010009	DOWEL PIN 6 X 22M
10	PCAP04M	CAP SCREW M6-1 X 10
11	PW03M	FLAT WASHER 6MM
12	PT23010012	GEAR 40T W/SPACER
13	PT23010013	GEAR SHAFT 40T
14	P6004ZZ	BALL BEARING 6004ZZ
15	PR09M	EXT RETAINING RING 20MM
16	PR24M	INT RETAINING RING 42MM
17	PT23010017	SLOTTED CONE SET SCREW M5-.8 X 8
18	PT23010018	GEAR SHAFT
19	PT23010019	GEAR 40T
20	PSS05M	SET SCREW M5-.8 X 10
21	PT23010021	PIVOT SHIFT
22	PT23010022	TRANSMISSION SHAFT
23	PT23010023	HUB BACK PLATE
24	PT23010024	PHLP HD SET SCREW M4-.7 X 10
25	PT23010025	CONE SET SCREW M4-.7 X 10
26	PT23010026	SHIFT KNOB
27	PSTB012M	STEEL BALL 6.5MM
28	PT23010028	COMPRESSION SPRING

REF	PART #	DESCRIPTION
29	PSS17M	SET SCREW M8-1.25 X 6
30	PT23010030	INDICATOR PLATE
31	PT23010031	DIRECTION SWITCH KEDU ZH-A3-06
32	PT23010032	RAPID SPEED SWITCH ONPOW LAS1-A
33	PT23010033	ON/OFF PADDLE SWITCH CQC 6A 125VAC
34	PT23010034	POTENTIOMETER ED 11 0-8 WX14-12
35	PSS26M	SET SCREW M5-.8 X 6
36	PT23010036	CONTROL PANEL
37	PT23010037	SHIFT FORK
38	PT23010038	BOTTOM COVER
39	PCAP38M	CAP SCREW M5-.8 X 25
40	PLW01M	LOCK WASHER 5MM
41	PW02M	FLAT WASHER 5MM
42	PT23010042	LEFT COVER
43	PT23010043	MOTOR 30W 90VDC 0.6A
44	PK134M	KEY 4 X 4 X 14
45	PT23010045	LIMIT SWITCH ASSEMBLY W/BACKET
46	PT23010046	LIMIT STOP
47	PCAP68M	CAP SCREW M6-1 X 8
48	PT23010048	T-SLOT NUT M6-1
49	PT23010049	POWER CORD 16G 3W 48" 5-15
50	PT23010050	MACHINE ID LABEL
51	PPAINT-1	GRIZZLY GREEN TOUCH-UP PAINT
52	PT23010052	FUSE 15A 250V 0.18" FAST-ACTING GLASS
53	PT23010053	FUSE HOLDER MF528

Parts breakdown provided for reference only. Not all parts shown are available for purchase.



Free Manuals Download Website

<http://myh66.com>

<http://usermanuals.us>

<http://www.somanuals.com>

<http://www.4manuals.cc>

<http://www.manual-lib.com>

<http://www.404manual.com>

<http://www.luxmanual.com>

<http://aubethermostatmanual.com>

Golf course search by state

<http://golfingnear.com>

Email search by domain

<http://emailbydomain.com>

Auto manuals search

<http://auto.somanuals.com>

TV manuals search

<http://tv.somanuals.com>