

# *Grizzly* **Industrial, Inc.**®

## **12½" LEAN & MEAN PORTABLE PLANER**

**MODEL G0505**

## **INSTRUCTION MANUAL**

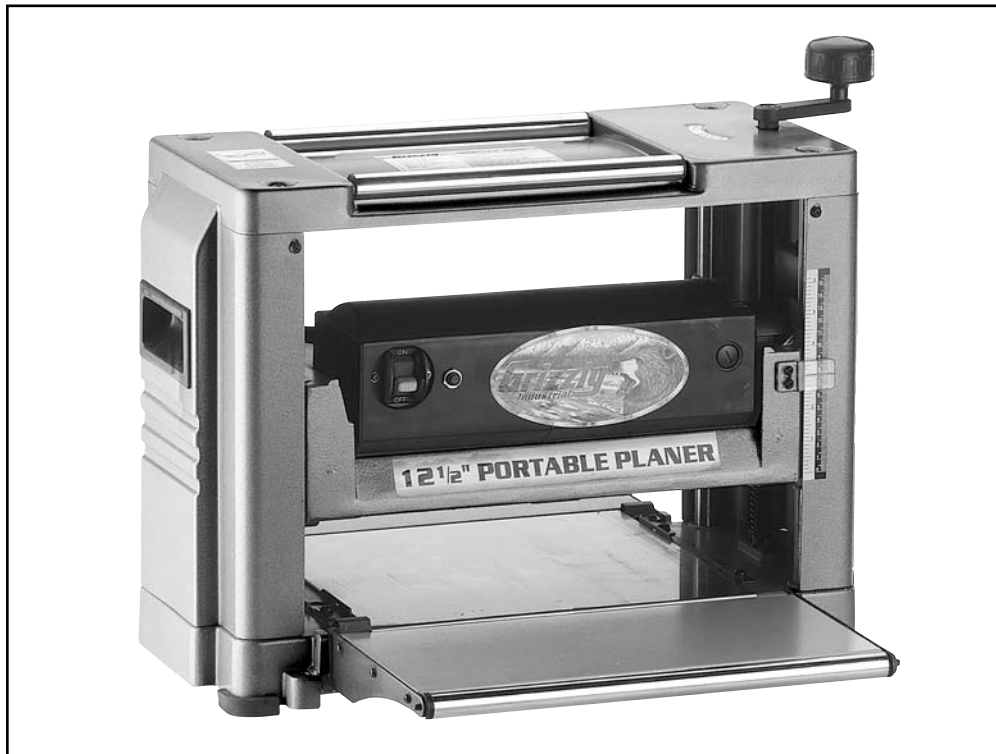

COPYRIGHT © DECEMBER, 2002 BY GRIZZLY INDUSTRIAL, INC.  
**WARNING: NO PORTION OF THIS MANUAL MAY BE REPRODUCED IN ANY SHAPE  
OR FORM WITHOUT THE WRITTEN APPROVAL OF GRIZZLY INDUSTRIAL, INC.**  
PRINTED IN CHINA

#### **ONLINE MANUAL DISCLAIMER**

THE INFORMATION IN THIS MANUAL REPRESENTS THE CONFIGURATION OF THE MACHINE AS IT IS CURRENTLY BEING SHIPPED. THE MACHINE CONFIGURATION CAN CHANGE AS PRODUCT IMPROVEMENTS ARE INCORPORATED. IF YOU OWN AN EARLIER VERSION OF THE MACHINE, THIS MANUAL MAY NOT EXACTLY DEPICT YOUR MACHINE. CONTACT CUSTOMER SERVICE IF YOU HAVE ANY QUESTIONS ABOUT DIFFERENCES. PREVIOUS VERSIONS ARE NOT AVAILABLE ONLINE.

# WARNING

Some dust created by power sanding, sawing, grinding, drilling, and other construction activities contains chemicals known to the State of California to cause cancer, birth defects or other reproductive harm. Some examples of these chemicals are:

- Lead from lead-based paints.
- Crystalline silica from bricks, cement, and other masonry products.
- Arsenic and chromium from chemically treated lumber.

Your risk from these exposures varies, depending on how often you do this type of work. To reduce your exposure to these chemicals: work in a well ventilated area, and work with approved safety equipment, such as those dust masks that are specially designed to filter out microscopic particles.

# Table Of Contents

	<b>PAGE</b>
<b>1. SAFETY</b> .....	<b>2</b>
SAFETY INSTRUCTIONS FOR POWER TOOLS .....	2-3
ADDITIONAL SAFETY INSTRUCTIONS FOR THE PORTABLE PLANER.....	4
<b>2. INTRODUCTION</b> .....	<b>5</b>
<b>3. CIRCUIT REQUIREMENTS</b> .....	<b>6</b>
110V OPERATION .....	6
GROUNDING .....	6
EXTENSION CORDS .....	6
<b>4. IDENTIFICATION</b> .....	<b>7</b>
CONTROLS & FEATURES.....	7
<b>5. SET UP</b> .....	<b>8</b>
UNPACKING .....	8
PIECE INVENTORY .....	8
HARDWARE RECOGNITION CHART .....	9
CLEAN UP .....	10
SITE CONSIDERATIONS.....	10
MOUNTING TO BENCH.....	11
HANDLE ASSEMBLY .....	11
CHIP DEFLECTOR.....	12
TEST RUN .....	12
<b>6. OPERATIONS</b> .....	<b>13</b>
ON/OFF SWITCH .....	13
RESET BUTTON .....	13
DEPTH OF CUT .....	14
PLANING TIPS .....	14
WOOD TYPES .....	15
WOOD CHARACTERISTICS .....	15-16
<b>7. MAINTENANCE</b> .....	<b>17</b>
GENERAL .....	17
KNIFE SHARPENING.....	17
MOTOR .....	18
V-BELT .....	18
FEED ROLLERS.....	19
LUBRICATION .....	19
<b>8. SERVICE ADJUSTMENTS</b> .....	<b>20</b>
EXTENSION WINGS .....	20
KNIFE SETTING .....	20-21
<b>9. REFERENCE INFO</b> .....	<b>22</b>
MACHINE DATA .....	23
PARTS BREAKDOWN AND PARTS LISTS .....	24-29
WARRANTY AND RETURNS.....	30

# SECTION 1: SAFETY

## WARNING

### For Your Own Safety Read Instruction Manual Before Operating This Equipment

The purpose of safety symbols is to attract your attention to possible hazardous conditions. This manual uses a series of symbols and signal words which are intended to convey the level of importance of the safety messages. The progression of symbols is described below. Remember that safety messages by themselves do not eliminate danger and are not a substitute for proper accident prevention measures.

 **DANGER** Indicates an imminently hazardous situation which, if not avoided, WILL result in death or serious injury.

 **WARNING** Indicates a potentially hazardous situation which, if not avoided, COULD result in death or serious injury.

 **CAUTION** Indicates a potentially hazardous situation which, if not avoided, MAY result in minor or moderate injury. It may also be used to alert against unsafe practices.

**NOTICE** This symbol is used to alert the user to useful information about proper operation of the equipment.

## WARNING

### Safety Instructions For Power Tools

1. **KEEP GUARDS IN PLACE** and in working order.
2. **REMOVE ADJUSTING KEYS AND WRENCHES.** Form habit of checking to see that keys and adjusting wrenches are removed from tool before turning on.
3. **KEEP WORK AREA CLEAN.** Cluttered areas and benches invite accidents.
4. **NEVER USE IN DANGEROUS ENVIRONMENT.** Do not use power tools in damp or wet locations, or where any flammable or noxious fumes may exist. Keep work area well lighted.
5. **KEEP CHILDREN AND VISITORS AWAY.** All children and visitors should be kept at a safe distance from work area.
6. **MAKE WORKSHOP CHILD PROOF** with padlocks, master switches, or by removing starter keys.
7. **NEVER FORCE TOOL.** It will do the job better and safer at the rate for which it was designed.
8. **USE RIGHT TOOL.** Do not force tool or attachment to do a job for which it was not designed.

# WARNING

## Safety Instructions For Power Tools

- 9. USE PROPER EXTENSION CORD.** Make sure your extension cord is in good condition. Conductor size should be in accordance with the chart below. The amperage rating should be listed on the motor or tool nameplate. An undersized cord will cause a drop in line voltage resulting in loss of power and overheating. Your extension cord must also contain a ground wire and plug pin. Always repair or replace extension cords if they become damaged.

Minimum Gauge for Extension Cords

AMP RATING	LENGTH		
	25ft	50ft	100ft
0-6	18	16	16
7-10	18	16	14
11-12	16	16	14
13-16	14	12	12
17-20	12	12	10
21-30	10	10	No

- 10. WEAR PROPER APPAREL.** Do not wear loose clothing, gloves, neckties, rings, bracelets, or other jewelry which may get caught in moving parts. Non-slip footwear is recommended. Wear protective hair covering to contain long hair.
- 11. ALWAYS USE SAFETY GLASSES.** Also use face or dust mask if cutting operation is dusty. Everyday eyeglasses only have impact resistant lenses, they are NOT safety glasses.
- 12. SECURE WORK.** Use clamps or a vise to hold work when practical. It's safer than using your hand and frees both hands to operate tool.
- 13. NEVER OVERREACH.** Keep proper footing and balance at all times.
- 14. MAINTAIN TOOLS WITH CARE.** Keep tools sharp and clean for best and safest performance. Follow instructions for lubricating and changing accessories.
- 15. DISCONNECT TOOLS** before servicing and changing accessories, such as blades, bits, cutters, and the like.
- 16. REDUCE THE RISK OF UNINTENTIONAL STARTING.** Make sure switch is in off position before plugging in. Also, the magnetic switch on this machine may start if the switch gets bumped hard enough.
- 17. USE RECOMMENDED ACCESSORIES.** Consult the owner's manual for recommended accessories. The use of improper accessories may cause risk of injury.
- 18. CHECK DAMAGED PARTS.** Before further use of the tool, a guard or other part that is damaged should be carefully checked to determine that it will operate properly and perform its intended function. Check for alignment of moving parts, binding of moving parts, breakage of parts, mounting, and any other conditions that may affect its operation. A guard or other part that is damaged should be properly repaired or replaced.
- 19. NEVER LEAVE TOOL RUNNING UNATTENDED. TURN POWER OFF.** Do not leave tool until it comes to a complete stop.
- 20. NEVER USE UNDER THE INFLUENCE** of alcohol or drugs, or when tired.
- 21. NEVER ALLOW UNSUPERVISED OR UNTRAINED PERSONNEL TO OPERATE THE MACHINE.** Make sure any instructions you give in regards to the operation of the machine are approved, correct, safe, and clearly understood.

## **WARNING**

# Additional Safety Instructions For The Portable Planer

1. Ensure that the machine is firmly secured to a bench or table before use.
2. Always be aware of the condition of the wood you are planing. Pay particular attention to knots, splits, and other potential areas where the grain may be getting ready to separate.
3. Perform machine inspection and maintenance services regularly as described in *Section 7: Maintenance*.
4. Make sure the planer knives are sharp, balanced, and set correctly and securely. Operate planer only with both knives in the cutterhead.
5. DO NOT plane any man-made composites such as plywood, hardboard, particle board, fiber board, flake board, fiberglass and/or any other material other than solid, natural wood fiber.
6. Position yourself so you do not get caught (pinned) between the lumber and another obstruction during the planing operation. Also, ensure that there is sufficient clearance for the material on the outfeed side of the planer.
7. Keep hands and fingers away from moving parts and away from the infeed and outfeed section of the planer. DO NOT reach into the machine at any time for any reason without first turning the power switch off, pulling the electrical plug and after the machine has come to a full stop.
8. Any glued-up stock must be completely set up and dry before planing.
9. Never leave the planer running unattended.
10. Habits – good and bad – are hard to break. Develop good habits in your shop and safety will become second-nature to you.

## **WARNING**

Like all power tools, there is danger associated with the Model G0505 Planer. Accidents are frequently caused by lack of familiarity or failure to pay attention. Use this tool with respect and caution to lessen the possibility of operator injury. If normal safety precautions are overlooked or ignored, serious personal injury may occur.

## **CAUTION**

No list of safety guidelines can be complete. Every shop environment is different. Always consider safety first, as it applies to your individual working conditions. Use this and other machinery with caution and respect. Failure to do so could result in serious personal injury, damage to equipment or poor work results.

# SECTION 2: INTRODUCTION

---

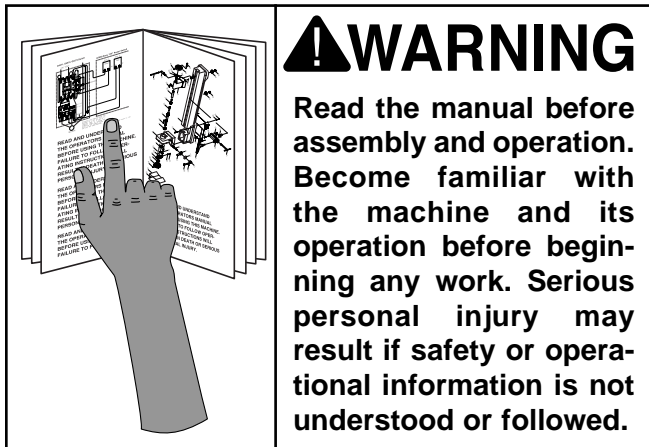

Grizzly Industrial, Inc. is proud to offer the Model G0505 12½" Portable Planer. This planer is a part of Grizzly's growing family of fine machinery. When used according to the guidelines described in this manual, you can expect years of trouble-free, enjoyable operation and proof of Grizzly's commitment to customer satisfaction.

The Model G0505 is a wood planer designed for portable or small shop use. This planer features a 2 HP motor, an easy top-mounted depth adjustment, fold-down extension wings, a direct reading thickness gauge, and convenient carry handles.

We are also pleased to provide this manual with the Model G0505. It was written to guide you through assembly, review safety considerations, and cover general operating procedures. It represents our effort to produce the best documentation possible. If you have any comments regarding this manual, please write to us at the address below:

Grizzly Industrial, Inc.  
c/o Technical Documentation  
P.O. Box 2069  
Bellingham, WA 98227-2069

Most important, we stand behind our machines. If you have any service questions or parts requests, please call or write us at the location listed below.

Grizzly Industrial, Inc.  
1203 Lycoming Mall Circle  
Muncy, PA 17756  
Phone: (570) 546-9663  
Fax: (800) 438-5901  
E-Mail: [techsupport@grizzly.com](mailto:techsupport@grizzly.com)  
Web Site: <http://www.grizzly.com>

The specifications, drawings, and photographs illustrated in this manual represent the Model G0505 as supplied when the manual was prepared. However, owing to Grizzly's policy of continuous improvement, changes may be made at any time with no obligation on the part of Grizzly. For your convenience, we always keep current Grizzly manuals available on our website at [www.grizzly.com](http://www.grizzly.com). Any updates to your machine will be reflected in these manuals as soon as they are complete. Visit our site often to check for the latest updates to this manual!



# SECTION 3: CIRCUIT REQUIREMENTS

## 110V Operation

The Model G0505 motor is designed to operate at 110V and includes a 110V plug.

Under normal 110V use, the motor draws approximately 10 amps. We recommend that you use a 15 amp circuit breaker or a 15 amp slow-blow fuse with your machine.

We also recommend that you use a dedicated circuit, (i.e., the Model G0505 should provide the only draw from that circuit). If frequent circuit failures occur when using the planer, contact our Service Department or your local electrical contractor.

### NOTICE

The Model G0505 cannot be rewired for 220V operation! Attempting to do this will void the warranty and will ruin the machine.



## Grounding

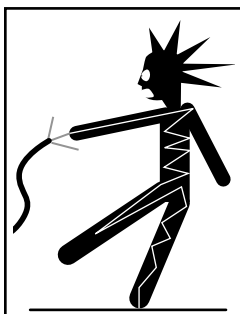

### WARNING

Electrocution or fire may result if this machine is not grounded correctly. Verify that any existing electrical outlet and circuit you intend to plug into is actually grounded. **DO NOT** use the machine if it is not grounded.

In the event of a malfunction or breakdown, grounding provides electric current a path of least resistance to reduce the risk of electric shock.

This tool is equipped with an electric cord having an equipment grounding conductor. Improper connections of the electrical-grounding conductor can result in the risk of electric shock. The conductor with green or green and yellow striped insulation is the electrical grounding conductor. If repair or replacement of the electric cord or plug is necessary, do not connect the equipment grounding conductor to a live terminal.

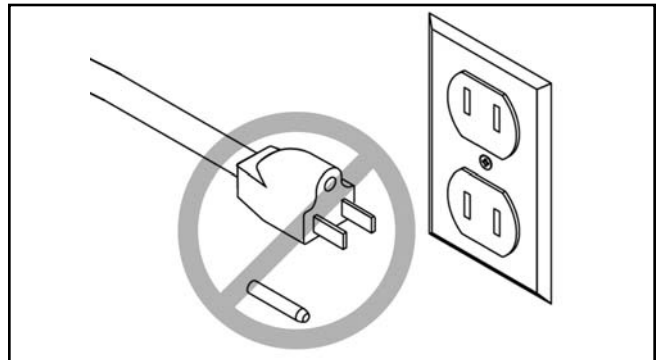

### CAUTION

This machine must have a ground prong in the plug to help ensure that it is grounded. **DO NOT** remove the ground prong from plug to fit into a two-pronged outlet! If the plug will not fit the outlet, have the proper outlet installed by a qualified electrician.



## Extension Cords

If you find it necessary to use an extension cord with this machine:

- Only use a Grade S or heavier-duty cord.
- Only use a cord with a grounding prong.
- Use at least a 18 gauge cord if the cord is 25 feet long or less.
- Use at least a 16 gauge cord if the cord is between 26-50 feet.
- Use at least a 14 gauge cord if the cord is between 51-100 feet.



G0505 12½" Lean & Mean Portable Planer



# SECTION 4: IDENTIFICATION

## Controls & Features

To help you understand the set up and operation instructions, become familiar with the basic features of your new planer.

Please match up the list below with the letters in **Figures 1 and 2** to identify the planer controls and features.

- A. Return Rollers
- B. ON/OFF Switch
- C. Reset Button
- D. Depth Indicator
- E. Cutterhead Elevation Handle
- F. Chip Deflector

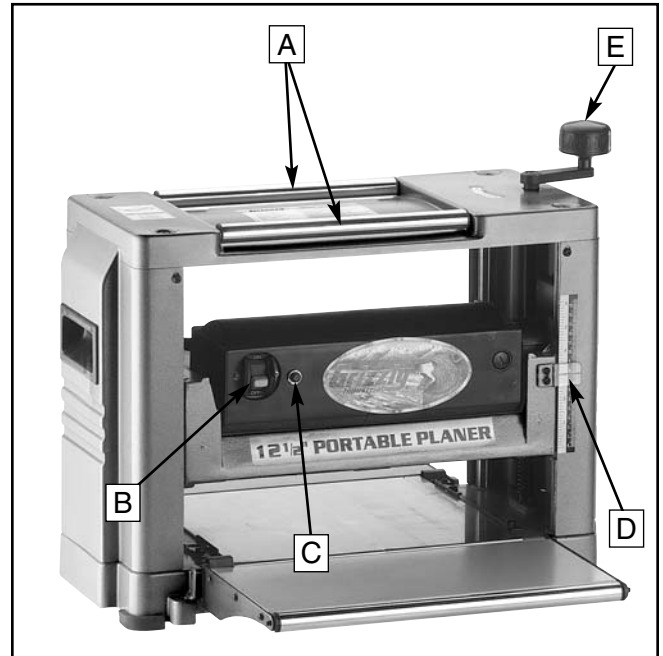

**Figure 1.** Model G0505 front view controls and features.

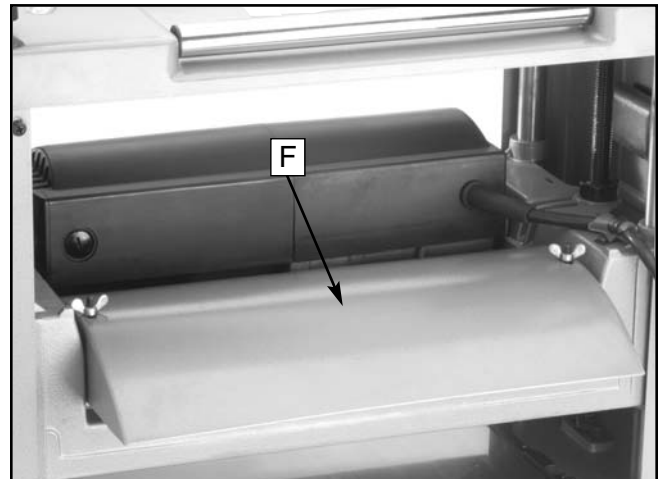

**Figure 2.** Model G0505 rear view controls and features.

# SECTION 5: SET UP

## Unpacking

The Model G0505 is shipped from the manufacturer in a carefully packed carton. If you discover the machine is damaged after you have signed for delivery, and the truck and driver are gone, you will need to file a freight claim with the carrier. Save the container and all packing materials for possible inspection by the carrier or its agent. Without the packing materials, filing a freight claim can be difficult. *If you need assistance determining whether you need to file a freight claim, or with the procedure to file one, please contact our Customer Service.*

	<p><b>⚠ CAUTION</b> The Model G0505 weighs approximately 71 lbs. <b>DO NOT over-exert yourself while unpacking or moving your machine—get assistance or use a fork lift.</b></p>
--	--

When you are completely satisfied with the condition of your shipment, you should inventory its parts.

	<p><b>⚠ CAUTION</b> Some metal parts may have sharp edges on them after they are formed. Please examine the edges of all metal parts before handling them. Failure to do so could result in injury.</p>
---	---



## Piece Inventory

After all the parts have been removed from the carton, you should have:

- Planer
- Chip Deflector
- Handle
- 8-10 mm Wrench
- Knife Gauge
- Hardware QTY
  - Cap Screw M5-.8 x 20mm .....(1)
  - Wing Nuts M5 .....(2)
  - Washers M5 .....(2)

In the event that any non-proprietary parts are missing (e.g. a nut or a washer), we would be glad to replace them, or for the sake of expediency, replacements can be obtained at your local hardware store.

<p style="text-align: center;"><b>NOTICE</b></p> <p>A full parts list and breakdown can be found towards the end of this manual. For easier assembly, or to identify missing parts, please refer to the detailed illustrations at the end of the manual.</p>
--



# Hardware Recognition Chart

Use this chart to match up hardware pieces during the assembly process!

MEASURE BOLT DIAMETER BY PLACING INSIDE CIRCLE

- 5/16"
- 3/8"
- 7/16"
- 1/2"
- 5/8"

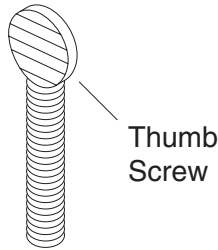

Thumb Screw

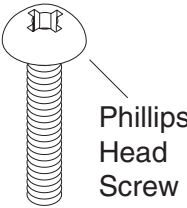

Phillips Head Screw

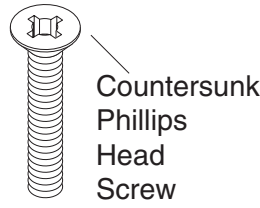

Countersunk Phillips Head Screw

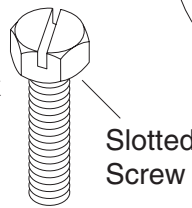

Slotted Screw

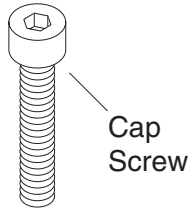

Cap Screw

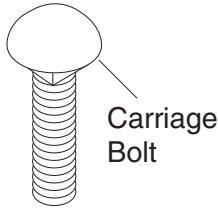

Carriage Bolt

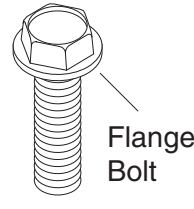

Flange Bolt

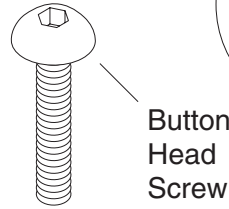

Button Head Screw

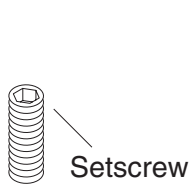

Setscrew

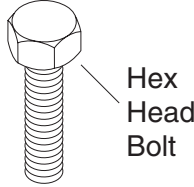

Hex Head Bolt

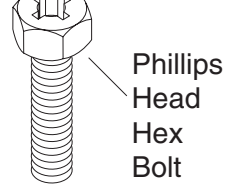

Phillips Head Hex Bolt

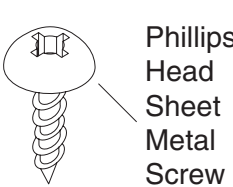

Phillips Head Sheet Metal Screw

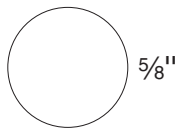

5/8"



Washer



Lock Washer

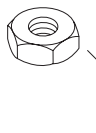

Hex Nut

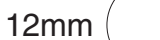
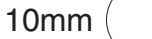
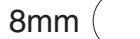
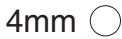

LINES ARE 1MM APART

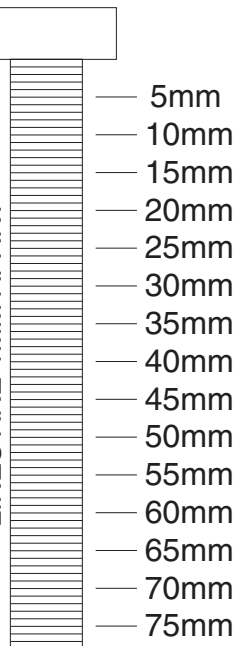

- 1/4"
- 3/8"
- 1/2"
- 5/8"

LINES ARE 1/16" INCH APART

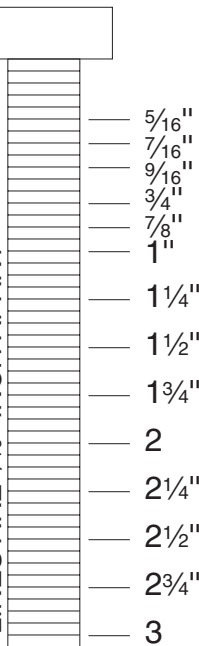

WASHERS ARE MEASURED BY THE INSIDE DIAMETER

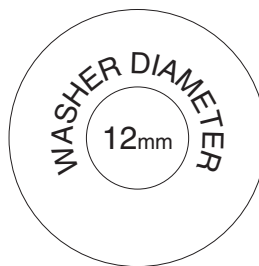

12mm



7/16"



3/8"



4mm



10mm



5/16"



6mm

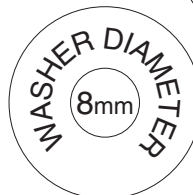

8mm



1/4"



#10

# Clean Up

The unpainted surfaces are coated with a waxy oil to protect them from corrosion during shipment. Remove this protective coating with a solvent cleaner or citrus-based degreaser such as Grizzly's G7895 Degreaser. To clean thoroughly, some parts may need to be removed. **For optimum performance from your machine, make sure you clean all moving parts or sliding contact surfaces that are coated.** Avoid chlorine-based solvents as they may damage painted surfaces should they come in contact. Always follow the manufacturer's instructions when using any type of cleaning product.

	<p><b>! WARNING</b> Do not use gasoline or other petroleum-based solvents to clean with. They have low flash points which make them extremely flammable. A risk of explosion and burning exists if these products are used.</p>
--	---

	<p><b>! WARNING</b> Do not smoke while using solvents. A risk of explosion or fire exists and may result in serious personal injury.</p>
---	--

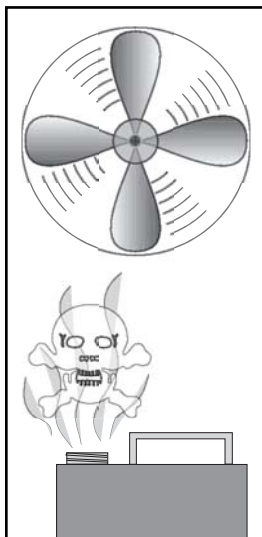
	<p><b>! CAUTION</b> Many of the solvents commonly used to clean machinery can be toxic when inhaled or ingested. Always work in well-ventilated areas far from potential ignition sources when dealing with solvents. Use care when disposing of waste rags and towels to be sure they do not create fire or environmental hazards.</p>
---	---

# Site Considerations

## FLOOR LOAD

Your new planer represents a small weight load in a small sized footprint. Most shop floors will be adequate for the weight of this machine, the workbench, the operator and the material being processed; however, some floors may require additional support. Contact an architect or structural engineer if you have any question about the ability of your floor to handle the weight.

## WORKING CLEARANCES

Working clearances can be thought of as the distances between machines and obstacles that allow safe operation of every machine without limitation. Consider existing and anticipated machine needs, size of material to be processed through each machine, and space for auxiliary stands or work tables. Also consider the relative position of each machine for efficient material handling. Be sure to allow yourself sufficient room to safely run your machines in any foreseeable operation.

## LIGHTING AND OUTLETS

Lighting should be bright enough to eliminate shadow and prevent eye strain. Electrical circuits should be dedicated or large enough to handle combined motor amp loads. Outlets should be located near each machine so power or extension cords are not obstructing high-traffic areas. Be sure to observe local electrical codes for proper installation of new lighting, outlets or circuits.

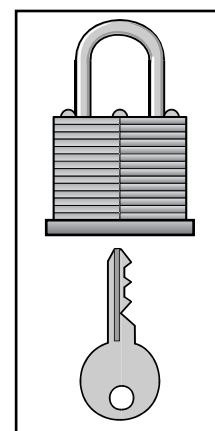
	<p><b>! CAUTION</b> Make your shop "child safe." Ensure that your workplace is inaccessible to children by closing and locking all entrances when you are away. <b>DO NOT</b> allow unsupervised children or visitors in the shop at any time.</p>
--	--



# Mounting to Bench

---

The planer can be directly mounted to a bench or table top, or to a Shop Fox® Deluxe Tool Table for increased stability during planing.

## To mount the planer:

1. Determine the correct length of hex bolts needed to mount the planer to your workbench. This will be the height of the planer mounting holes, plus the thickness of your workbench, plus an extra ½" for washers and the hex nut.
2. From the hardware store, get (4) ½" hex bolts that meet the length requirements for your setup. Also get (8) ½" flat washers, (4) ½" lock washers, and (4) ½" hex nuts.
3. Mount the planer to your workbench with your hardware in the order shown in **Figure 3**.

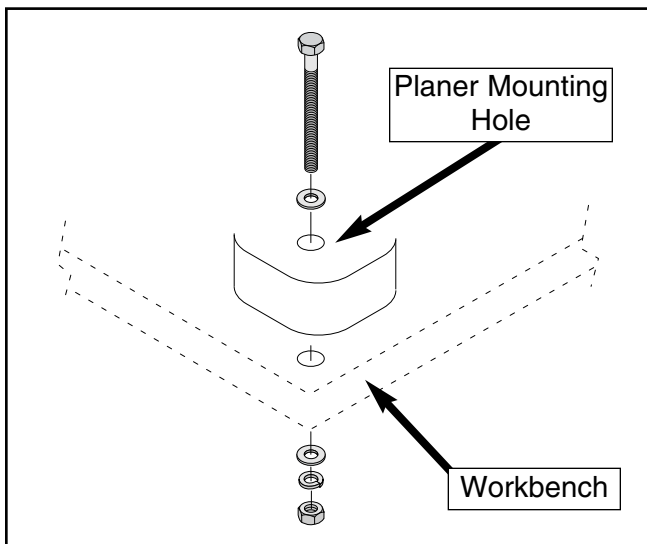

**Figure 3.** Mounting planer to bench.



# Handle Assembly

---

## To attach the handle assembly:

1. Align the flat portion inside the handle bore with the flat portion on the shaft.
2. Insert the handle assembly on the shaft that protrudes out of the top of the planer (see **Figure 4**).
3. Thread the M5-.8 x 20mm cap screw through the handle and into the shaft to secure the handle in place. **DO NOT** over-tighten.



**Figure 4.** Attaching handle.



# Chip Deflector

---

---

For your safety and for the proper operation of the machine, ensure that the chip deflector is secured before operation. The chip deflector directs wood chips away from the cutterhead during operation, and it covers the cutterhead and feed rollers for operator safety.

## To secure the chip deflector:

1. Align the chip deflector with the two studs mounted at the exit side of the planer.
2. Set chip deflector in place and use the two wing nuts and washers to secure. See **Figure 5**.

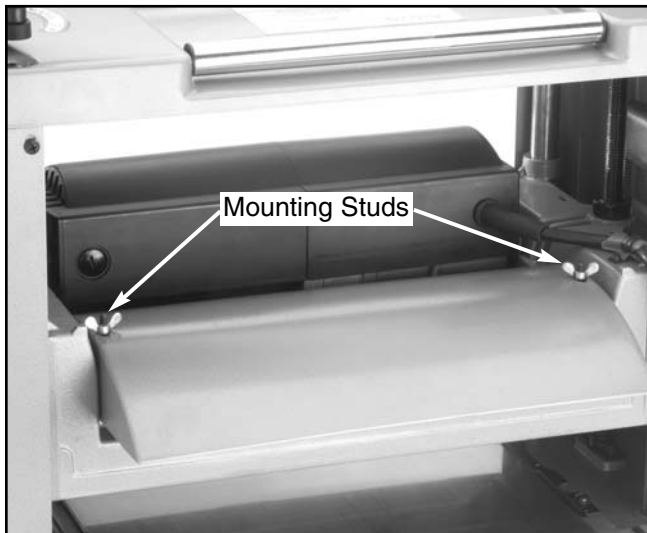

**Figure 5.** Chip deflector mounting studs.



# Test Run

---

---

Once assembly is complete, you are ready to test run the machine.

## **WARNING**

**DO NOT attempt to investigate or adjust the machine while it is running. Wait until the machine is turned off, unplugged and all working parts have come to a complete stop before you do anything!**

## To test run the planer:

1. Plug the planer into the power source.
2. Move the ON/OFF switch to the *ON* position. Make sure that your finger is poised on the STOP button, just in case there is a problem.
3. Run the Model G0505 for a short time to ensure that the moving parts are working properly with no excessive vibration.

The planer should run smoothly, with little or no vibration or rubbing noises. Strange or unnatural noises should be investigated and corrected before operating the machine further.

If any problem develops, correct it before attempting to use the machine.

If you cannot locate the source of unusual noises, contact our service department for help.





# SECTION 6: OPERATIONS

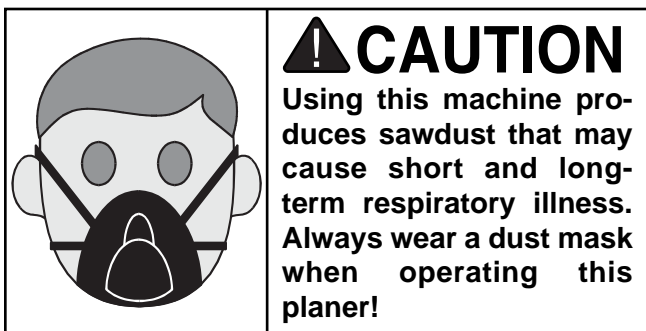
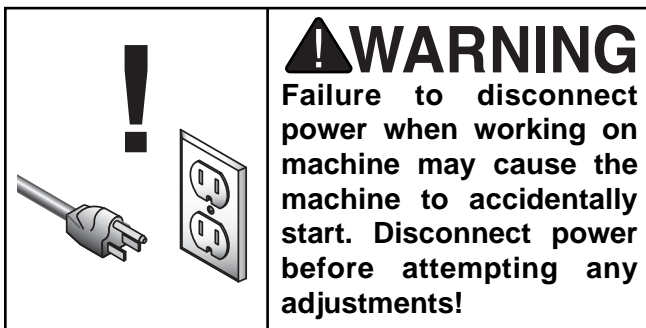
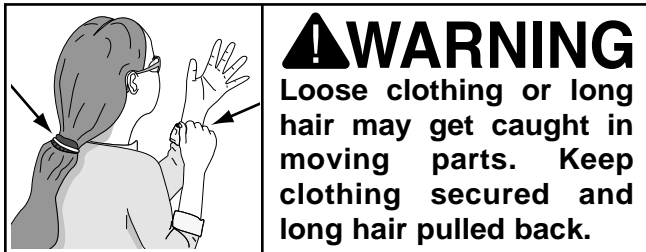
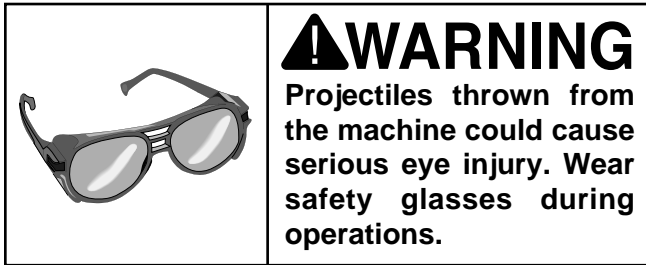

## NOTICE

The following section was designed to give instructions on the basic operations of this planer. However, it is in no way comprehensive of every planing application. **WE STRONGLY RECOMMEND** that you read books, trade magazines, or get formal training to maximize the potential of your planer.

## ON/OFF Switch

The ON/OFF switch is located on the front of the planer. See **Figure 6**. The switch has a key that, when removed, allows it to be locked in the *OFF* position. To access the locking feature, push the switch to the *OFF* position and pull the switch key out. Should the key be removed when the planer is *ON*, it can still be turned *OFF*, but it will not be able to be restarted until the key is replaced.

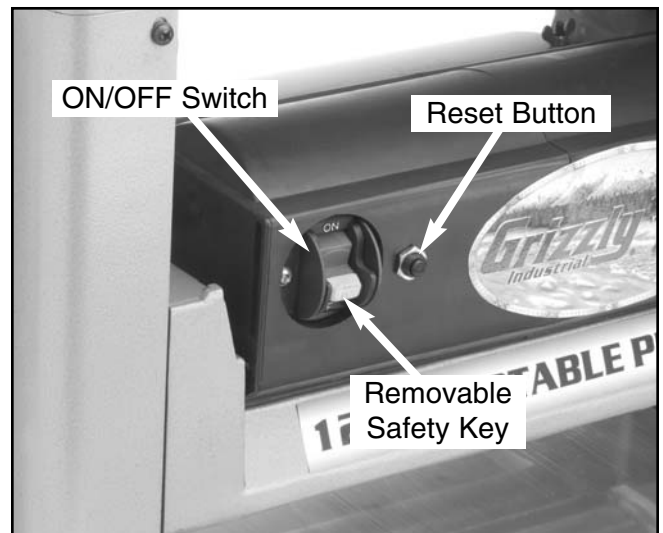

**Figure 6.** Location of switch and reset button.



## Reset Button

The G0505 Planer comes equipped with a thermal overload protection switch which will trip if the motor gets too hot. To reset the switch, turn the switch to the *OFF* position, wait a few minutes and then depress the reset button. See **Figure 6**. If the reset button does not stay depressed, wait longer before resetting to allow the machine to cool down.



## Depth Of Cut

---

The planing depth is controlled by the crank handle on top of the planer. Turning the handle clockwise raises the cutterhead and turning it counter-clockwise lowers the cutterhead. See **Figure 7**. Depth-of-cut is read directly from the inch/millimeter scale located on the top, right-hand side of the planer. One complete turn of the handle raises or lowers the cutterhead approximately  $\frac{5}{64}$ " (2mm). The range of material thickness that can be planed is  $\frac{3}{16}$ " - 6" (5mm - 152mm).

The maximum depth-of-cut varies according to the hardness of the wood and how wide of a board is being passed under the cutterhead. Generally, we recommend a maximum depth of no more than  $\frac{1}{32}$ ". A series of light cuts will give a better end result than trying to take off too much material in a single pass, plus there is less strain on the motor.

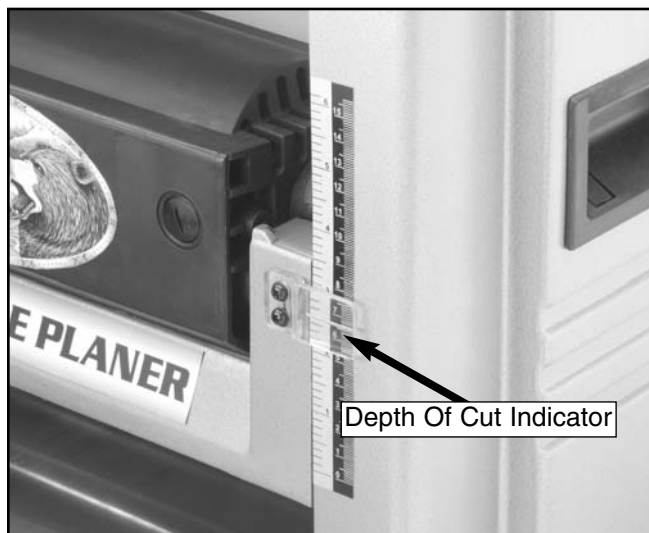

**Figure 7.** Depth of cut scale and indicator.



## Planing Tips

---

- Inspect your lumber for twisting or cupping, and surface one face on a jointer if necessary.
- Scrape all glue off when planing glued-up panels.
- DO NOT plane more than one piece at a time.
- Remove only  $\frac{1}{32}$ " (.8mm) of material on each pass. Remove less material on each pass when planing wide or dense stock.
- Support the workpiece on both ends. Get assistance if you are planing long lumber, or use roller stands to support the workpiece.
- Measure the workpiece thickness with calipers to get exact results.
- Carefully inspect all stock to make sure it is free of large knots or foreign objects that may damage your blades.
- When possible, plane equal amounts on each side of the board to reduce the chance of twisting or cupping.
- Use the entire width of the planer to wear knives evenly.
- Always plane WITH the grain direction of the wood. Never plain cross-grain or end-grain.







# Wood Types



The species of wood, as well as its condition, has a dramatic effect on the depth of cut the planer can effectively take with each pass. The harder the wood (as illustrated by its shear strength), the shallower the depth of cut should be.

Commonly used hardwoods and their associated shear strengths are illustrated in **Figure 8**.

	Type	Shear (PSI)
 Increasing Difficulty 	Black Locust	2,480
	Sugar Maple	2,330
	Pecan Hickory	2,080
	White Oak	2,000
	White Ash	1,950
	Black Cherry	1,700
	American Elm	1,510
	Black Walnut	1,370
	Red Alder	1,080
	Basswood	980
Cottonwood	930	

**Figure 8.** Common hardwood shear strengths.

Similarly, common softwood shear strengths are displayed in **Figure 9**.

	Type	Shear (PSI)
 Increasing Difficulty 	Western Larch	1,410
	Tamarack	1,280
	Douglas Fir	1,160
	Alaska Cedar	1,130
	Sitka Spruce	1,150
	Sugar Pine	1,050
	Cypress	1,000
	Redwood (OG)	940
	Red Cedar	860
	White Pine	850
	Balsam Fir	710

**Figure 9.** Common softwood shear strengths.



# Wood Characteristics

Below is a list of wood characteristics you may encounter when planing. The following descriptions of defects will give you some possible answers to problems you may encounter while planing different materials. Possible solutions follow the descriptions.

## Chipped Grain

*Problem*—Usually a result of cutting against the grain, planing lumber with knots or excessive amount of cross grain, or using dull knives.

*Solution*—Decrease depth of cuts. Inspect your lumber and determine if its grain pattern is causing the problem. If the lumber does not show substantial crossgrain, sharpen your knives.

## Fuzzy Grain

*Problem*—Usually caused by surfacing lumber with too high of a moisture content. Sometimes fuzzy grain is an unavoidable characteristic of some woods, such as basswood. Fuzzy grain can also be caused by dull knives.

*Solution*—Check the lumber with a moisture meter. If moisture is greater than 20%, sticker the lumber and allow to dry. Otherwise, inspect the knife condition.

## Glossy Surface

*Problem*—Usually caused by dull knives or too slow of a feed speed. Surface gloss will usually be accompanied by overheating. Often, lumber will be scorched and damage to knives will occur.

*Solution*—Use sharp knives and increase the feed speed.

## Snipe

*Problem*—Occurs when board ends have more material removed than the rest of the board. Usually caused when the workpiece is not properly supported as it goes through the machine. However, a small amount of snipe is inevitable.

*Solution*—The best way to deal with snipe is by planing lumber longer than your intended work length and then cutting off the excess after planing is completed.

### **Wavy Surface**

*Problem*—Caused by poor knife height adjustment, wavy surface appears when one knife is taking deeper cuts than the rest of the knives.

*Solution*—Reset knife height with the gauge.

### **Pitch & Glue Build-up**

*Problem*—Glue and resin build-up on the rollers and cutterhead will cause overheating by decreasing cutting sharpness while increasing drag in the feed mechanism. The result can include scorched lumber as well as uneven knife marks and chatter.

*Solution*—Clean the rollers and cutterhead.

### **Chip Marks or Indentations**

*Problem*—Chip indentation or chip bruising is the result of wood chips not being thrown away from the cutterhead and out of the dust chute. Instead they are carried around the cutterhead, deposited on the planed surface and crushed by the outfeed roller. Chip indentations can be caused by a number of reasons, some of which are:

- a. The type of lumber being planed. Certain species have a tendency to chip bruise.
- b. A high moisture content (over 15%) and/or surface moisture. Typically found in air-dried stock where the surface is dry but the inside needs a longer time to season.
- c. Dull knives.
- d. Too much material being removed in one pass.

*Solution*—

- a. Lumber must be completely dry, preferably kiln-dried (KD). Air-dried (AD) lumber must be seasoned properly and have no surface moisture. DO NOT surface partially-air-dried (PAD) lumber.
- b. Make sure planer knives are sharp.
- c. Reduce depth of cut.



# SECTION 7: MAINTENANCE

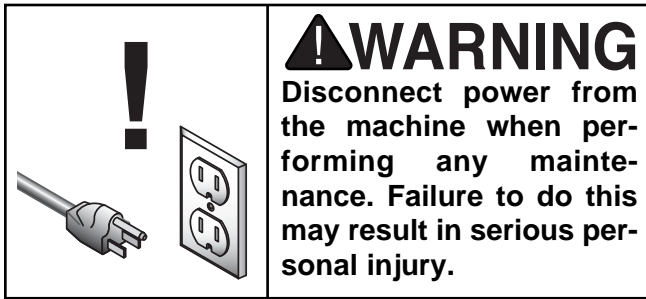

## General

Regular periodic maintenance on your Model G0505 Planer will ensure its optimum performance. Make a habit of inspecting your planer each time you use it. Check for the following conditions and repair or replace when necessary:

- Loose mounting bolts, extension wings, or handles, or excessive play in the depth-of-cut adjustment.
- Worn switch.
- Worn or damaged cords or plugs.
- Dull or damaged cutterhead knives.
- Any condition that could hamper the safe operation of the machine.



## ⚠ CAUTION

The cutterhead knives on the Model G0505 are extremely sharp. Brushing your finger along the edge can result in a severe cut. Take extreme caution when doing any of the adjustments involving the cutterhead knives. Wear thick gloves anytime it is necessary to manually rotate the cutterhead assembly.

## Knife Sharpening

Knife sharpness is one of the most important factors in getting good results with the planer. Knives can be used for a long time if care is taken in checking the condition of the wood before putting it into the machine. The biggest problem will come from wood with nails, pebbles, or other hard embedded objects. These items will nick or chip the knives, causing permanent damage. Another wear factor is sand, grit, or other dirt on the surface of the wood. At the speed the cutterhead is rotating, these types of surface contamination can have a very abrasive effect.

This planer has knives with a grind angle of 40° which is a configuration that should suit most general planing needs. The optimal grind or bevel angle is a compromise between effective cutting (the smaller the angle, the better the cutting action) and edge life (the larger the angle, the more the edge is supported, and thus, the longer it will last).

For the best results, have your planer knives sharpened by a professional sharpening service that has the grinding and measurement equipment to assure that the knife cutting geometry is maintained at optimum levels. Resharpenering is a procedure that requires some care and precision; otherwise, a set of blades can be easily ruined.

Also, knives should always be ground as a set so they can be properly matched. Unequal material removal can result in an unbalanced cutterhead which can affect not only planing surface quality but ultimately the life of the cutterhead bearings.

To avoid downtime, we recommend having an extra set of knives for your planer (Model H5038 in the Grizzly catalog or website).

Please refer to *Section 8: Service Adjustments* for complete detail on the removal and reinstallation of planer knives.



---

---

# Motor

Keep the motor as clean as possible. Prevent any water, oil or wood chips from penetrating inside the motor. Be sure to clean the machine after every use.

The bearings inside the motor are also shielded and lubricated for the life of the bearing and require no routine maintenance.

This motor is equipped with long life carbon brushes. However, brush life expectancy is affected by motor loading. Planing very wide, dense boards or cutting too deep will reduce brush life. Check brushes after every ten to fifteen hours of operation. See **Figure 10**. When the brushes are



**Figure 10.** Brush holder location (another brush is located on the other side of the motor from the one shown in this picture).

worn down to 1/4" (6mm), it is time for replacement. When checking brushes, be sure to replace each brush in the same position and the same location that it came from. When replacing old brushes, be sure to replace both brushes at the same time.



---

---

# Belt

The cutterhead is driven by a belt that is located on the right-hand side of the motor and cutterhead assembly (when facing the front of the machine). The belt is very durable, however eventually it may require replacement.

## To replace the belt:

1. Remove the elevation handle and the 2 phillips head screws on the front and rear of the side cover. Pull the cover off.
2. Remove the Belt Guard shown in **Figure 11** by removing the 2 phillips head screws that secure it.
3. Roll the old belt off, toward the side of the elevation screw.
4. Loop the new belt so that it completely surrounds the motor pulley but with only half of the "vees" engaged. Start the lower portion on the underside of the cutterhead pulley and slowly rotate the motor pulley with your free hand.
5. By pushing on the edge of the belt and slowly turning the pulleys by hand, you can force the belt over until all the "vees" are in alignment with the "vees" on the pulleys.
6. Replace the belt guard, side cover, and handle.

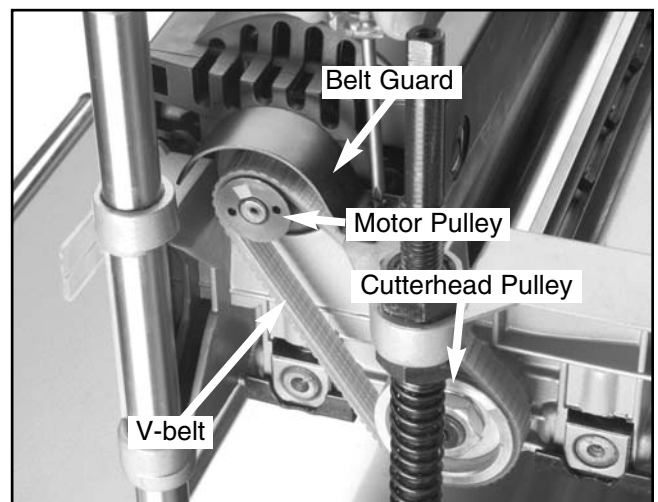
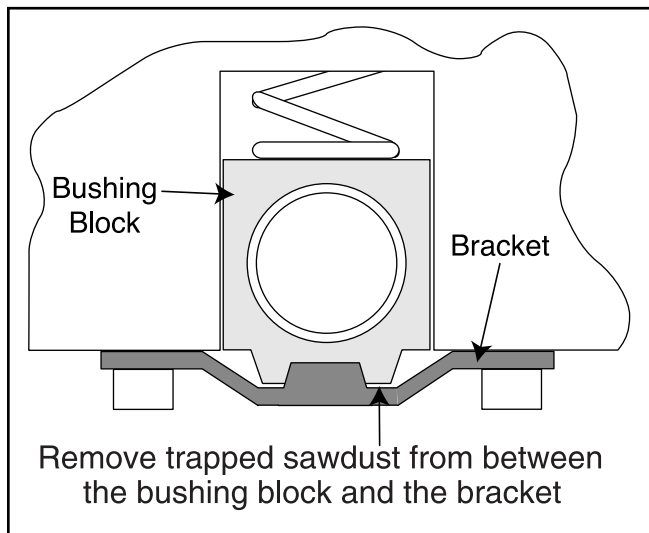

**Figure 11.** Cutterhead drive components.



# Feed Rollers

The feed rollers rotate in bushing blocks that are spring loaded. The feed rollers ride up on the board so that the roller pressure is maintained. If chips or sawdust build up between the bracket and bushing block, the amount of roller vertical travel will be reduced. See **Figure 12**.



**Figure 12.** Location of potential trapped sawdust.

Periodically check and clean chips and sawdust from between the bushing blocks and brackets. Remove the top cover, then remove the sides. This provides easy access to depress the rollers so that chips and sawdust can be easily removed.

## To clean the feed rollers:

1. Place a 3"-4" high block of wood between one of the feed rollers and the planer bed. Ensure that the block of wood is not under the cutterhead.
2. Lower the cutterhead assembly down just enough so that the roller is pushed up against the spring and pressure is off of the two brackets.
3. Remove any trapped material from between the roller assembly and bracket.
4. Raise the cutterhead assembly and remove the block of wood.

5. Repeat **steps 1-4** for the other feed roller.
6. Replace the sides, cover and elevation handle.



# Lubrication

There are two primary points that require periodic lubrication—the head elevation screws and the feed roller chain drive. Access for lubrication requires removing the cover and sides of the machine first. See **Figure 13**.

The elevation screws on each side of the machine should be coated with a light grease to lubricate the threads.

The chain drive can be lubricated with a spray oil. Saturate each chain link, then wipe off the excess so that sawdust will not be attracted.

Replace the sides, cover and handle when complete.

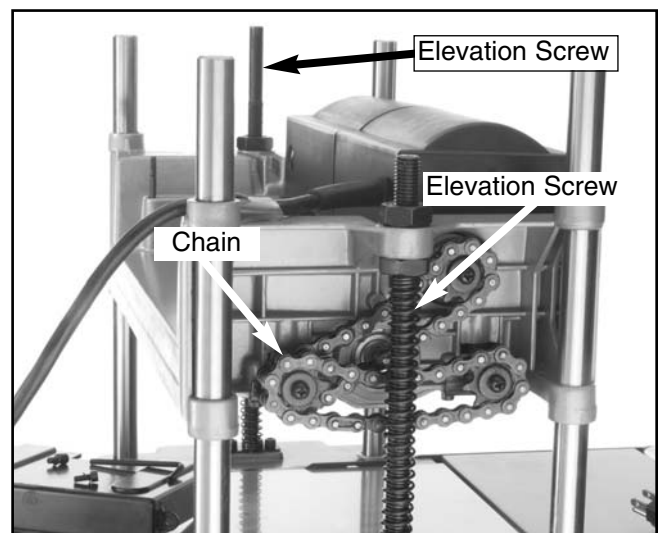

**Figure 13.** Lubrication points of chain and elevation screws.



# SECTION 8: SERVICE ADJUSTMENTS

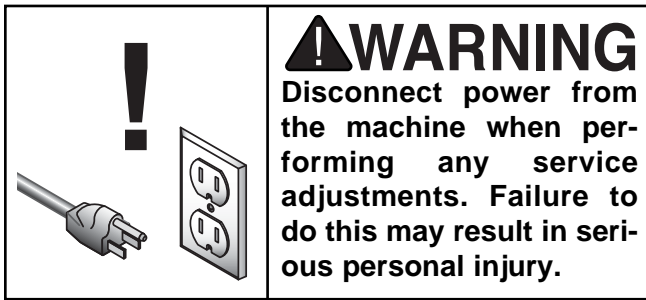

## Extension Wings

Your planer is equipped with front and rear extension wings. Each wing folds up for machine mobility and folds down for machine operation. To check the alignment, lay a straightedge across the bed and both wings. See **Figure 14**.

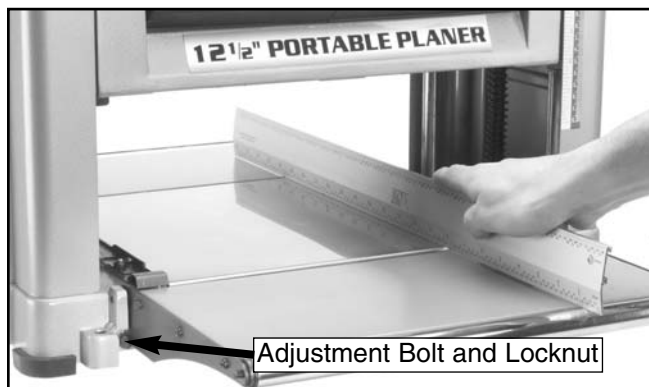

**Figure 14.** Aligning extension wings.

If adjustment is necessary, proceed as follows:

1. Use the 10mm wrench and loosen the locking nuts and set bolts underneath each extension wing.
2. Hold a straightedge across the bed and both wings, and turn the adjustment bolts so the wings are parallel to the table.
3. Without turning the set bolts, tighten the lock nuts. Recheck to ensure consistency from side-to-side.



## Knife Setting

The Model G0505 is equipped with a 2 blade cutterhead. The blades are locked in position by a knife locking bar with seven bolts that are angled to put pressure on the assembly when they are tightened. A set of two springs under each blade pushes up to keep the blade portion exposed. The knife setting gauge is used to push down on the blade to set it to the proper height.

To remove the knives:

1. **Disconnect the planer from the power source!**
2. Lower the cutterhead as far as it will go.
3. Remove the chip deflector.
4. Use the provided 8mm wrench to loosen the gib bolts in the knife locking bar. **Turn clockwise to loosen bolts and free the knife!** (See **Figure 15**)
5. Slide the knife out of the cutterhead. Use care when handling knives—they are sharp!
6. Repeat **steps 3-4** above to remove the second knife.

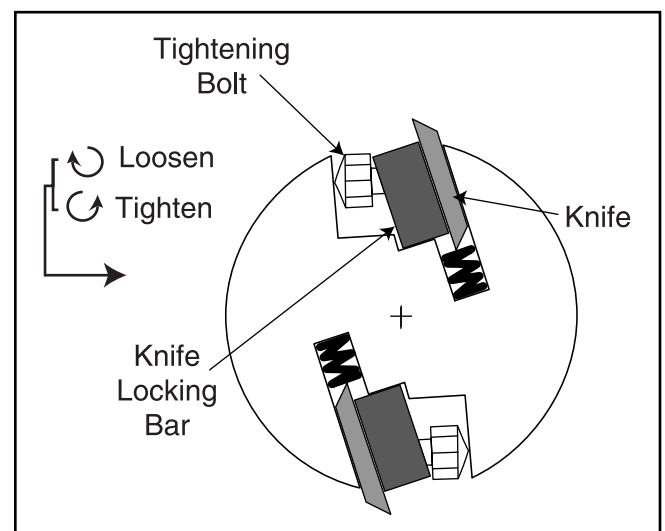

**Figure 15.** Turn tightening bolt clockwise to loosen. G0505 12½" Lean & Mean Portable Planer

## To install and adjust the knives:

1. Make sure the two springs in the knife groove are in position. If the knife locking bar was removed, make certain it is re-inserted with the bolts oriented as shown in **Figure 16**.

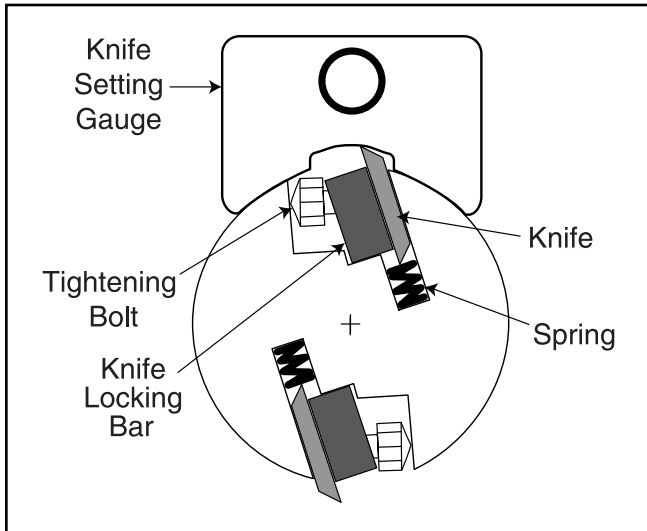

**Figure 16.** Side view of cutterhead and gauge.

2. Insert the knife into the space between the cutterhead and the locking bar. Make sure the bevel side of the knife is against the cutterhead.
3. Position the knife setting gauge on the cutterhead, as shown in **Figure 17**.

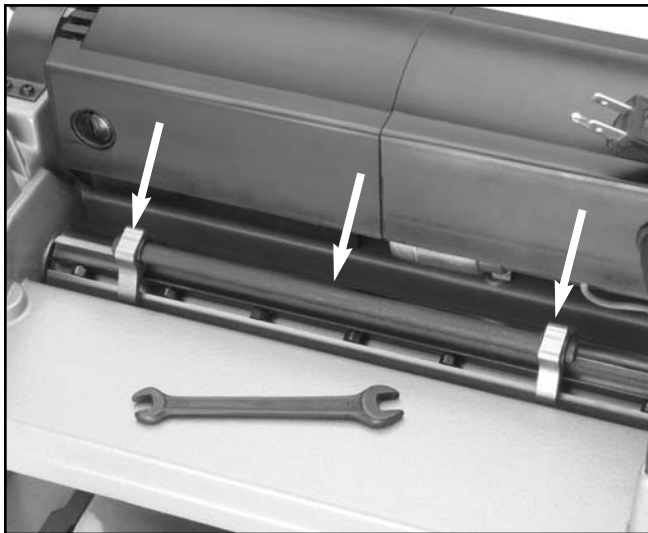

**Figure 17.** Knife gauge positioned on cutterhead.

4. While holding the knife setting gauge with one hand so it sits firmly on the cutterhead, turn the gib bolts counterclockwise with the other hand. Tighten the seven bolts until they begin to contact the side of the groove. Then tighten further, starting with the bolts at the center and working toward the outer bolts. Once all the bolts are tight enough to hold the knife in position, remove the gauge.
5. Repeat **steps 1-5** above to set the second knife.
6. Final tighten each gib bolt. Recheck with the setting gauge to make certain the knives did not move. The knife tip should be barely touching the top of the arc of the gauge as shown in **Figure 17**.
7. **Remove all tools** and install the chip deflector.

## **⚠️ WARNING**

**Make sure the Model G0505 is unplugged or disconnected from the power source and moving parts have come to a complete stop before investigating any problems or performing any maintenance or adjustments. Serious personal injury may occur.**

## **⚠️ CAUTION**

**The cutterhead knives on the Model G0505 are extremely sharp. Merely brushing your finger along the edge can result in a severe cut. Take extreme caution when doing any adjustments involving the cutterhead knives. Wear thick gloves anytime it is necessary to manually rotate the cutterhead assembly.**





# SECTION 9: REFERENCE INFO

---

The following pages contain general machine data, parts diagrams/lists and Warranty/Return information for your Model G0505 12<sup>1</sup>/<sub>2</sub>" Portable Planer.

If you need parts or help in assembling your machine, or if you need operational information, we encourage you to call our Service Department. Our trained service technicians will be glad to help you.

If you have comments dealing specifically with this manual, please write to our Bellingham, Washington location using the address in *Section 2: Introduction*. The specifications, drawings, and photographs illustrated in this manual represent the Model G0505 as supplied when the manual was prepared. However, due to Grizzly's policy of continuous improvement, changes may be made at any time with no obligation on the part of Grizzly. Whenever possible, though, we send manual updates to all owners of a particular tool or machine. Should you receive one, add the new information to this manual and keep it for reference.

We have included some important safety measures that are essential to this machine's operation. While most safety measures are generally universal, Grizzly reminds you that each workshop is different and safety rules should be considered *as they apply to your specific situation*.

We recommend you keep a copy of our current catalog for complete information regarding Grizzly's warranty and return policy. If you need additional technical information relating to this machine, or if you need general assistance or replacement parts, please contact the Service Department listed in *Section 3: Introduction*.

Additional information sources are necessary to realize the full potential of this machine. Trade journals, woodworking magazines, and your local library are good places to start.

## WARNING

**The Model G0505 was specifically designed for *PLANING*. DO NOT modify and/or use this machine for any other purpose. Modifications or improper use of this tool will void the warranty. If you are confused about any aspect of this machine, DO NOT use it until you have answered all your questions. Serious personal injury may occur.**







# MACHINE DATA SHEET

Customer Service #: (570) 546-9663 • To Order Call: (800) 523-4777 • Fax #: (800) 438-5901

## MODEL G0505 12 1/2" LEAN & MEAN PORTABLE PLANER

Design Type .....Bench Model

### Overall Dimensions:

Table Size.....12 1/2" x 11 1/2"  
 Table Extensions (2) .....14 1/2" x 7 1/2"  
 Height .....18 3/4" with Knob  
 Length (with Extensions) .....27 3/8"  
 Width.....21 3/4"  
 Shipping Weight.....77 lbs.  
 Net Weight .....71 lbs.  
 Base Footprint .....20 7/8" x 10 1/2"  
 Knives (Number / Dimensions) .....(2) 12 1/2" L x 1/8" T x 23/32" H, Double Edged

### Capacities:

Maximum Depth of Cut .....3/32"  
 Maximum Width of Cut .....12 1/2"  
 Minimum Stock Thickness .....13/64"  
 Minimum Stock Length .....6"  
 Cutterhead Diameter.....1 7/8" (48mm)  
 Cutterhead RPM .....10,000 RPM  
 Cuts Per Minute .....20,000  
 Cuts Per Inch .....52  
 Feed Rate .....32 FPM  
 Maximum Cutting Height .....6"

### Construction:

Table .....Steel/ Cast Aluminum  
 Power Feed Rollers .....Rubber  
 Extensions .....Stamped Steel w/1 Roller  
 Cutterhead Bearings .....Shielded & Lubricated Ball Bearings  
 Support Columns (4) .....Steel  
 Knives .....High Speed Steel

### Motor:

Type .....Universal Fan-Cooled  
 Horsepower.....2 HP  
 Phase / Voltage .....Single-Phase / 110V  
 Amps .....15  
 Cycle / RPM .....60 Hertz / 19,000 R.P.M.  
 Switch .....On / Off Safety Toggle  
 Power Transfer .....Belt Drive  
 Bearings .....Shielded & Lubricated Ball Bearings

### Features:

.....Fold-down Extension Tables  
 .....Top Mounted Depth Adjustment  
 .....Thermal Overload Protection  
 .....Convenient Carry Handles On Side  
 .....Return Rollers  
 .....Included Knife Setting Jig & Wrench

**Specifications, while deemed accurate, are not guaranteed.**

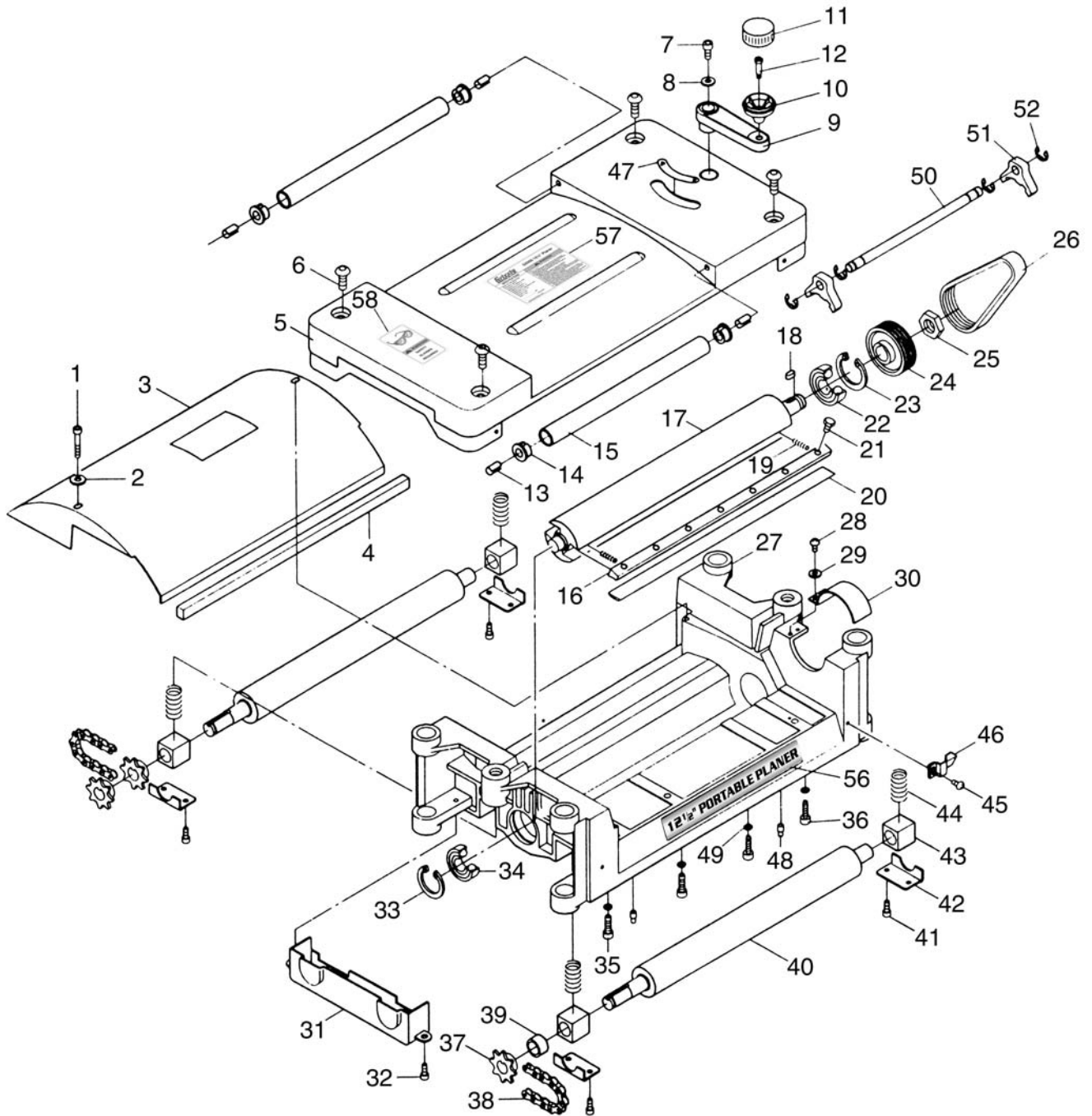

REF	PART #	DESCRIPTION
1	PSB95M	CAP SCREW M5-.8 X 30
2	PLW01M	LOCK WASHER 5MM
3	P0505003	CHIP GUARD
4	P0505004	SPONGE PIECE
5	P0505005	UPPER GUARD
6	PSB11M	CAP SCREW M8-1.25 X 16
7	PSB01M	CAP SCREW M6-1 X 16
8	PLW03M	LOCK WASHER 6MM
9	P0505009	HANDLE SET
10	P0505010	HAND KNOB
11	P0505011	HANDLE GUARD
12	P0505012	HANDLE SHAFT
13	PRP07M	ROLL PIN 6 X 20
14	P0505014	BUSHING
15	P0505015	ROLLER
16	P0505016	GIB
17	P0505017	CUTTERHEAD
18	PK06M	KEY 5 X 5 10
19	P0505019	SPRING
20	P0505020	KNIFE
21	P0505021	GIB LOCK SCREW 1/4"-28
22	P6203	BEARING 6203
23	PR23M	INT RETAINING RING 40MM
24	P0505024	CUTTERHEAD PULLEY
25	PN29M	HEX NUT M18-2.5
26	P0505026	BELT 135-J6
27	P0505027	UPPER FRAME

REF	PART #	DESCRIPTION
28	PS07M	PHLP HD SCR M4-.7 X 8
29	PW05M	FLAT WASHER 4MM
30	P0505030	PULLEY GUARD
31	P0505031	CHAIN GUARD
32	PS05M	PHLP HD SCR M5-.8 X 8
33	PR21M	INT RETAINING RING 35MM
34	P6202	BEARING 6202
35	PSB02M	CAP SCREW M6-1 X 20
36	PHTEK7M	TAP SCREW M6 X 20
37	P0505037	CHAIN SPROCKET
38	P0505038	CHAIN
39	P0505039	SPACING COLLAR
40	P0505040	RUBBER ROLLER
41	PS09M	PHLP HD SCR M5-.8 X 10
42	P0505042	BRACKET PLATE
43	P0505043	ROLLER BRACKET
44	P0505044	BRACKET SPRING
45	PS07M	PHLP HD SCR M4-.7 X 8
46	P0505046	INDICATOR
47	P0505047	INDICATION LABEL
48	P0505048	FRAME PIN
49	PLW03M	LOCK WASHER 6MM
50	P0505050	GAUGE ROD
51	P0505051	KNIFE SETTING GUIDE
52	PEC10M	E-CLIP 9MM
56	P0505056	12 1/2" PLANER LABEL
57	P0505057	MACHINE ID LABEL
58	PLABEL-12	SAFETY GLASSES LABEL

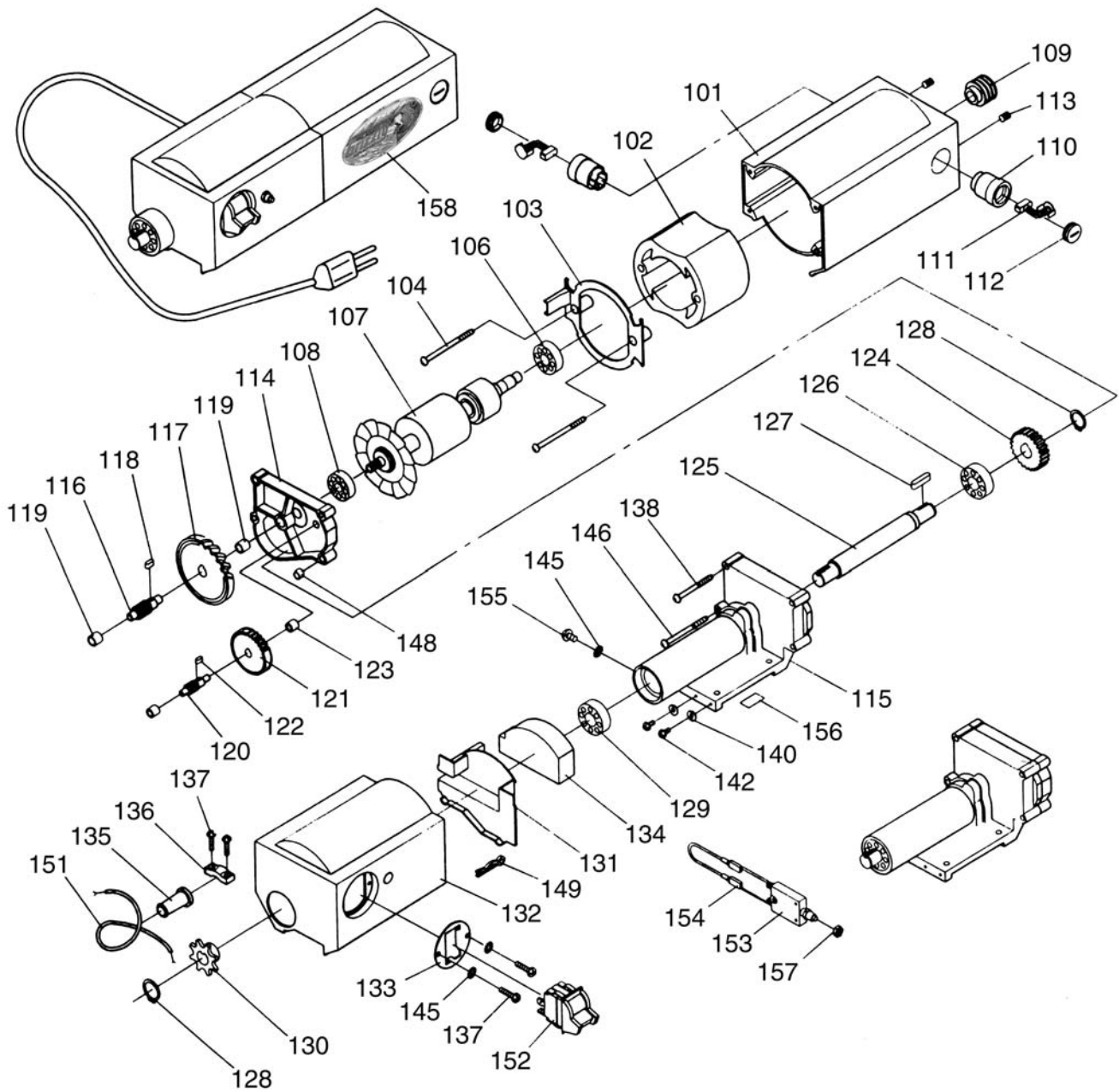

REF	PART #	DESCRIPTION
100	P0505100	MOTOR ASSEMBLY
101	P0505101	MOTOR CASING
102	P0505102	STATOR ASSEMBLY
103	P0505103	PLATE
104	PHTEK14	TAP SCREW #10 X 2 3/4"
106	P6201	BEARING 6201
107	P0505107	ROTOR ASSEMBLY
108	P0505108	BEARING
109	P0505109	MOTOR PULLEY
110	P0505110	CARBON BRUSH COVER
111	P0505111	CARBON BRUSH
113	PSS05M	SET SCREW M5-.8 X 10
114	P0505114	GEAR BOX COVER
115	P0505115	GEAR BOX
116	P0505116	GEAR SHAFT
117	P0505117	GEAR 70T
118	PK04M	KEY 4 X 4 X 8
119	P0505119	BRONZE BRUSH
120	P0505120	GEAR SHAFT
121	P0505121	GEAR 46T
122	PK73M	KEY 3 X 3 X 7
123	P0505123	BUSHING
124	P0505124	GEAR 33T
125	P0505125	SHAFT
126	P6202	BEARING 6202
127	PK05M	KEY 4 X 4 X 10

REF	PART #	DESCRIPTION
128	PR05M	EXT RETAINING RING 15MM
129	P6002	BEARING 6002
130	P0505130	CHAIN SPROCKET
131	P0505131	SPACING PLATE
132	P0505132	DUST GUARD PLUG
133	P0505133	SWITCH GUARD (BLACK)
133	P0505133	SWITCH PLATE
134	P0505134	DUST GUARD PLUG
135	P0505135	SAFETY WIRE BALL
136	P0505136	ELECTRICAL WIRE CLAMP
137	PHTEK6M	TAP SCREW M4 X 16
138	PHTEK15	TAP SCREW #10 X 2"
140	PW05M	FLAT WASHER 4MM
142	PS07M	PHLP HD SCR M4-.7 X 8
145	PTLW02M	EXT TOOTH WASHER 5MM
146	PHTEK16	TAP SCREW #10 X 2 5/16
148	P0505148	POSITIONING PIN
149	P0505149	R TYPE PLUG SSP-10
151	P0505151	POWER WIRES
152	P0505152	SAFETY SWITCH
153	P0505153	TEMPERATURE SWITCH
154	P0505154	TEMPERATURE
155	PS05M	PHLP HD SCR M5-.8 X 8
156	P0505156	MOTOR LABEL
157	PN02M	HEX NUT 10MM
158	P0505158	GRIZZLY LABEL (COLOR)

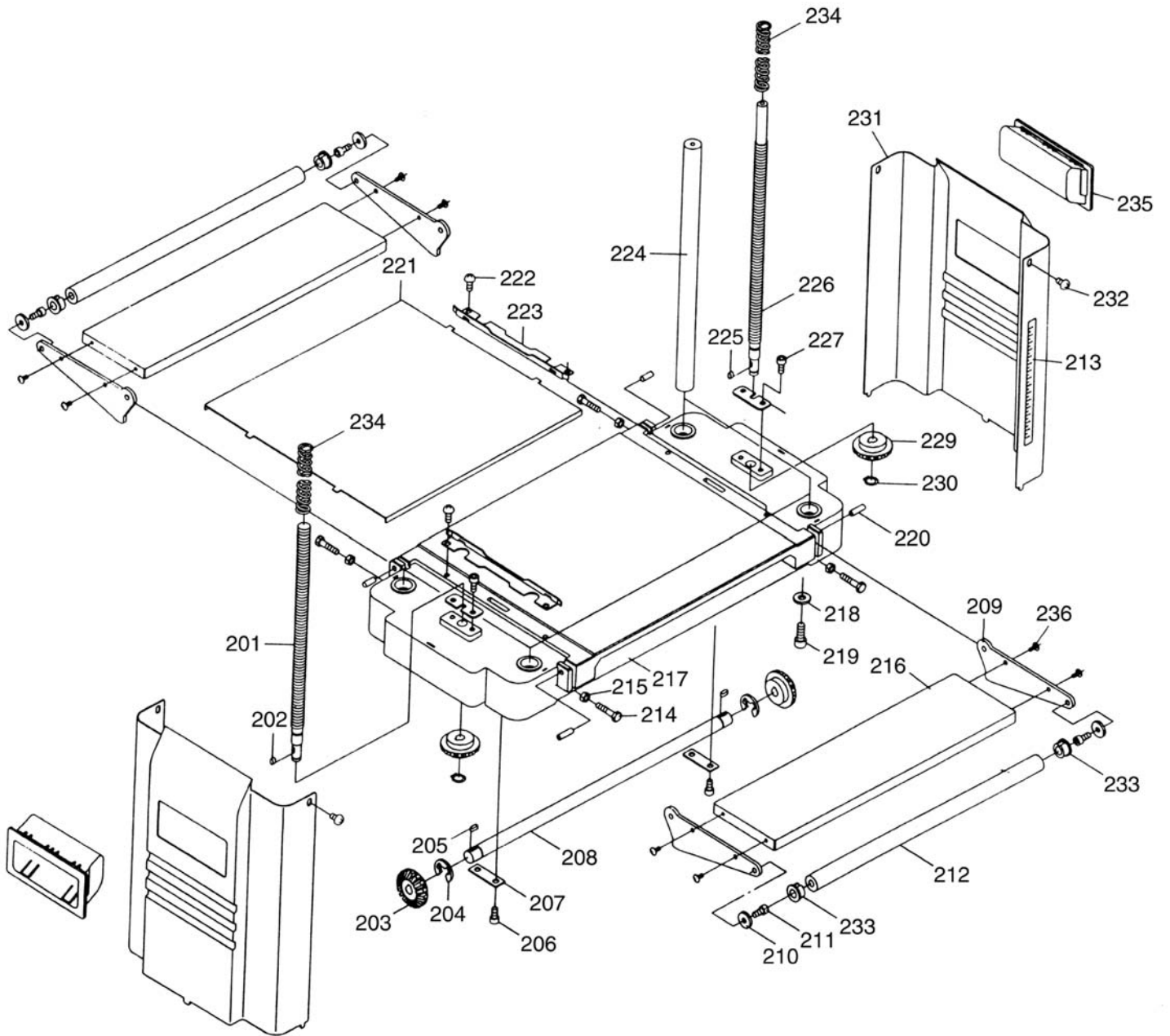

REF	PART #	DESCRIPTION
200	P0505200	BASE ASSEMBLY
201	P0505201	LEFT COLUMN SCREW
202	P0505202	KEY 4 X 4 X 8
203	P0505203	BEVEL GEAR
204	P0505204	E-CLIP 8MM
205	PK04M	KEY 4 X 4 X 8
206	PSB04M	CAP SCREW M6-1 X 10
207	P0505207	FIXING PIECE
208	P0505208	TRANSMISSION SHAFT
209	P0505209	TABLE EXTENSION BRACKET
210	PW03M	FLAT WASHER 6MM
211	P0505211	EXT BRACKET M6-1 X 8
212	P0505212	TABLE EXTENSION ROLLER
213	P0505213	DEPTH SCALE
214	PB10M	HEX BOLT M6-1 X 25
215	PN01M	HEX NUT M6-1
216	P0505216	TABLE EXTENSION
217	P0505217	BASE
218	PW07	FLAT WASHER 5/16"

REF	PART #	DESCRIPTION
219	PSB14M	CAP SCREW M8-1.25 X 20
220	PRP07M	ROLL PIN 6 X 20
221	P0505221	PAD
222	PS24M	PHLP HD SCR M6-1 X 10
223	P0505223	GUIDE PLATE
224	P0505224	COLUMN
225	PK04M	KEY 4 X 4 X 8
226	P0505226	RIGHT COLUMN SCREW
227	PSB04M	CAP SCREW M6-1 X 10
228	P0505228	FIXING PIECE
229	P0505229	BEVEL GEAR
230	PR01M	EXT RETAINING RING 10MM
231	P0505231	SIDE GUARD
232	PS19M	PHLP HD SCR M5-.8 X 6
233	P0505233	ROLLER BUSHING
234	P0505234	SCREW SPRING
235	P0505235	CARRYING HANDLE
236	PS07M	PHLP HD SCR M4-.7 X 8

# WARRANTY AND RETURNS

---

---

Grizzly Industrial, Inc. warrants every product it sells for a period of **1 year** to the original purchaser from the date of purchase. This warranty does not apply to defects due directly or indirectly to misuse, abuse, negligence, accidents, repairs or alterations or lack of maintenance. This is Grizzly's sole written warranty and any and all warranties that may be implied by law, including any merchantability or fitness, for any particular purpose, are hereby limited to the duration of this written warranty. We do not warrant or represent that the merchandise complies with the provisions of any law or acts unless the manufacturer so warrants. In no event shall Grizzly's liability under this warranty exceed the purchase price paid for the product and any legal actions brought against Grizzly shall be tried in the State of Washington, County of Whatcom.

We shall in no event be liable for death, injuries to persons or property or for incidental, contingent, special, or consequential damages arising from the use of our products.

To take advantage of this warranty, contact us by mail or phone and give us all the details. We will then issue you a "Return Number," which must be clearly posted on the outside as well as the inside of the carton. We will not accept any item back without this number. Proof of purchase must accompany the merchandise.

The manufacturers reserve the right to change specifications at any time because they constantly strive to achieve better quality equipment. We make every effort to ensure that our products meet high quality and durability standards and we hope you never need to use this warranty.

Please feel free to write or call us if you have any questions about the machine or the manual.

Thank you again for your business and continued support. We hope to serve you again soon.



# WARRANTY CARD

Name \_\_\_\_\_

Street \_\_\_\_\_

City \_\_\_\_\_ State \_\_\_\_\_ Zip \_\_\_\_\_

Phone Number \_\_\_\_\_ E-Mail \_\_\_\_\_ FAX \_\_\_\_\_

MODEL #G0505 12-1/2" Portable Planer Order # \_\_\_\_\_ Serial # \_\_\_\_\_

The following information is given on a voluntary basis. It will be used for marketing purposes to help us develop better products and services. Of course, all information is strictly confidential.

1. How did you learn about us?
- Advertisement  Friend  
 Catalog  Card Deck  
 World Wide Web  
 Other \_\_\_\_\_
2. Which of the following magazines do you subscribe to.
- American Woodworker  Practical Homeowner  
 Cabinetmaker  Shop Notes  
 Family Handyman  Today's Homeowner  
 Fine Homebuilding  WOOD  
 Fine Woodworking  Wooden Boat  
 Home Handyman  Woodshop News  
 Journal of Light Construction  Woodsmith  
 Old House Journal  Woodwork  
 Popular Mechanics  Woodworker  
 Popular Science  Woodworker's Journal  
 Popular Woodworking  Workbench  
 Other \_\_\_\_\_
3. Which of the following woodworking/remodeling shows do you watch?
- Backyard America  The New Yankee Workshop  
 Home Time  This Old House  
 The American Woodworker  Woodwright's Shop  
 Other \_\_\_\_\_
4. What is your annual household income?
- \$20,000-\$29,999  \$60,000-\$69,999  
 \$30,000-\$39,999  \$70,000-\$79,999  
 \$40,000-\$49,999  \$80,000-\$89,999  
 \$50,000-\$59,999  \$90,000 +
5. What is your age group?
- 20-29  50-59  
 30-39  60-69  
 40-49  70 +
6. How long have you been a woodworker?
- 0 - 2 Years  8 - 20 Years  
 2 - 8 Years  20+ Years
7. How would you rank your woodworking skills?
- Simple  Advanced  
 Intermediate  Master Craftsman
8. What stationary woodworking tools do you own? Check all that apply.
- Air Compressor  Panel Saw  
 Band Saw  Miter Saw  
 Drill Press  Power Feeder  
 Drum Sander  Radial Arm Saw  
 Dust Collector  Shaper  
 Horizontal Boring Machine  Spindle Sander  
 Jointer  Table Saw  
 Lathe  Vacuum Veneer Press  
 Mortiser  Wide Belt Sander  
 Other \_\_\_\_\_
9. How many of your woodworking machines are Grizzly? \_\_\_\_\_
10. Which benchtop tools do you own? Check all that apply.
- 1" x 42" Belt Sander  6" - 8" Grinder  
 5" - 8" Drill Press  Mini Lathe  
 8" Table Saw  10" - 12" Thickness Planer  
 8" - 10" Bandsaw  Scroll Saw  
 Disc/Belt Sander  Spindle/Belt Sander  
 Mini Jointer  
 Other \_\_\_\_\_
11. How many of the machines checked above are Grizzly? \_\_\_\_\_
12. Which portable/hand held power tools do you own? Check all that apply.
- Belt Sander  Orbital Sander  
 Biscuit Joiner  Palm Sander  
 Circular Saw  Portable Planer  
 Detail Sander  Saber Saw  
 Drill/Driver  Reciprocating Saw  
 Miter Saw  Router  
 Other \_\_\_\_\_
13. What machines/supplies would you like Grizzly Industrial to carry?
- 12" Table Saw  Radial Arm Saw  
 12" Jointer  Panel Saw  
 Combination Planer/Jointer  Brass Hardware  
 Paint & Finishing Supplies  Lumber  
 Contractor's Supplies  
 Other \_\_\_\_\_
14. What new accessories would you like Grizzly Industrial to carry?
- Builders Hardware  Hand Tools  
 Fasteners  Wood Components  
 Other \_\_\_\_\_
15. What other companies do you purchase your tools and supplies from?  
\_\_\_\_\_  
\_\_\_\_\_
16. Do you think your purchase represents good value?  
 Yes  No
17. Would you recommend Grizzly Imports to a friend?  
 Yes  No
18. Would you allow us to use your name as a reference for Grizzly customers in your area? **Note: We never use names more than three times.**  
 Yes  No
19. Comments: \_\_\_\_\_  
\_\_\_\_\_  
\_\_\_\_\_  
\_\_\_\_\_  
\_\_\_\_\_

CUT ALONG DOTTED LINE

FOLD ALONG DOTTED LINE

---

---

---



Place  
Stamp  
Here

***Grizzly***  
***Industrial, Inc.***<sup>®</sup>  
GRIZZLY INDUSTRIAL, INC.  
P.O. BOX 2069  
BELLINGHAM, WA 98227-2069



FOLD ALONG DOTTED LINE

Send a Grizzly Catalog to a friend:

Name _____
Street _____
City _____ State _____ Zip _____

TAPE ALONG EDGES--PLEASE DO NOT STAPLE

# *grizzly.com*

**TOOL WEBSITE**

Buy Direct and Save with Grizzly® – Trusted, Proven and a Great Value!

*Visit Our Website Today And Discover Why  
Grizzly® Is The Industry Leader!*

- SECURE ORDERING
- ORDERS SHIPPED WITHIN 24 HOURS
- E-MAIL RESPONSE WITHIN ONE HOUR

-OR-

Call Today For A **FREE**  
Full Color Catalog  
**1-800-523-4777**



## Free Manuals Download Website

<http://myh66.com>

<http://usermanuals.us>

<http://www.somanuals.com>

<http://www.4manuals.cc>

<http://www.manual-lib.com>

<http://www.404manual.com>

<http://www.luxmanual.com>

<http://aubethermostatmanual.com>

Golf course search by state

<http://golfingnear.com>

Email search by domain

<http://emailbydomain.com>

Auto manuals search

<http://auto.somanuals.com>

TV manuals search

<http://tv.somanuals.com>