

Grizzly **Industrial, Inc.**®

MODEL G0477 15" PLANER/MOULDER OWNER'S MANUAL



COPYRIGHT © APRIL, 2006 BY GRIZZLY INDUSTRIAL, INC. REVISED SEPTEMBER, 2014 (ST)

**WARNING: NO PORTION OF THIS MANUAL MAY BE REPRODUCED IN ANY SHAPE
OR FORM WITHOUT THE WRITTEN APPROVAL OF GRIZZLY INDUSTRIAL, INC.**

#JK8066 PRINTED IN CHINA



WARNING!

This manual provides critical safety instructions on the proper setup, operation, maintenance, and service of this machine/tool. Save this document, refer to it often, and use it to instruct other operators.

Failure to read, understand and follow the instructions in this manual may result in fire or serious personal injury—including amputation, electrocution, or death.

The owner of this machine/tool is solely responsible for its safe use. This responsibility includes but is not limited to proper installation in a safe environment, personnel training and usage authorization, proper inspection and maintenance, manual availability and comprehension, application of safety devices, cutting/sanding/grinding tool integrity, and the usage of personal protective equipment.

The manufacturer will not be held liable for injury or property damage from negligence, improper training, machine modifications or misuse.



WARNING!

Some dust created by power sanding, sawing, grinding, drilling, and other construction activities contains chemicals known to the State of California to cause cancer, birth defects or other reproductive harm. Some examples of these chemicals are:

- **Lead from lead-based paints.**
- **Crystalline silica from bricks, cement and other masonry products.**
- **Arsenic and chromium from chemically-treated lumber.**

Your risk from these exposures varies, depending on how often you do this type of work. To reduce your exposure to these chemicals: Work in a well ventilated area, and work with approved safety equipment, such as those dust masks that are specially designed to filter out microscopic particles.

Table of Contents

| | |
|--|-----------|
| INTRODUCTION..... | 2 |
| Manual Accuracy..... | 2 |
| Contact Info..... | 2 |
| Machine Data Sheet..... | 3 |
| Identification..... | 5 |
| SECTION 1: SAFETY..... | 6 |
| Safety Instructions for Machinery..... | 6 |
| Additional Safety for Planer/Moulders..... | 8 |
| SECTION 2: POWER SUPPLY..... | 9 |
| SECTION 3: SET UP..... | 11 |
| Items Needed for Set Up..... | 11 |
| Unpacking..... | 11 |
| Inventory..... | 12 |
| Clean Up..... | 13 |
| Site Considerations..... | 13 |
| Stand Assembly..... | 14 |
| Mounting Planer/Moulder on Stand..... | 15 |
| Dust Chute and Bag..... | 15 |
| Crank Handle..... | 16 |
| Test Run..... | 16 |
| SECTION 4: OPERATIONS..... | 17 |
| Operation Safety..... | 17 |
| Safety Switch Key..... | 17 |
| Basic Operation..... | 17 |
| Operation Tips..... | 18 |
| Feed Speed..... | 18 |
| Headstock Height Adjustment..... | 19 |
| Preset Thickness Settings..... | 19 |
| Roller Height Adjustment..... | 20 |
| Moulding Knives..... | 21 |
| Setting Up Moulding Fence Guide..... | 22 |
| Adjusting Moulding Guide Fence..... | 22 |
| Edge Moulding..... | 22 |
| SECTION 5: ACCESSORIES..... | 24 |
| SECTION 6: MAINTENANCE..... | 25 |
| Schedule..... | 25 |
| Cleaning..... | 25 |
| Anti-Kickback Fingers..... | 25 |
| Unpainted Metal..... | 25 |
| Lubrication..... | 25 |
| SECTION 7: SERVICE..... | 26 |
| Troubleshooting Guide..... | 26 |
| Changing Planing Knives..... | 28 |
| Changing Belts..... | 29 |
| Chain Tension and Headstock Leveling..... | 29 |
| Changing Motor Brushes..... | 30 |
| Electrical Components..... | 31 |
| Wiring Diagram..... | 32 |
| G0477 Body Breakdown..... | 33 |
| G0477 Table and Base Breakdown..... | 34 |
| G0477 Gearbox Breakdown..... | 35 |
| G0477 Stand Breakdown..... | 36 |
| G0477 Labels..... | 37 |
| Parts List..... | 38 |
| WARRANTY AND RETURNS..... | 45 |

INTRODUCTION

Manual Accuracy

We are proud to offer this manual with your new machine! We've made every effort to be exact with the instructions, specifications, drawings, and photographs of the machine we used when writing this manual. However, sometimes we still make an occasional mistake.

Also, owing to our policy of continuous improvement, **your machine may not exactly match the manual**. If you find this to be the case, and the difference between the manual and machine leaves you in doubt, check our website for the latest manual update or call technical support for help.

Before calling, find the manufacture date of your machine by looking at the date stamped into the machine ID label (see below). This will help us determine if the manual version you received matches the manufacture date of your machine.

| Grizzly Industrial | | MODEL GXXXX MACHINE NAME |
|------------------------------------|---------------|--|
| SPECIFICATIONS | | ▲ WARNING! |
| Motor: | | ing this machine: |
| Specification: | | operation. |
| Specification: | | s and respirator. |
| Specification: | | sted/setup and |
| Weight: | | suit before starting. |
| | Date | 4. make sure the motor has stopped and disconnect |
| | Serial Number | power before adjustments, maintenance, or service. |
| | | 5. DO NOT expose to rain or dampness. |
| | | 6. DO NOT modify this machine in any way. |
| | | 7. DO NOT remove safety guards. |
| | | 8. Never leave machine running unattended. |
| | | 9. DO NOT operate under the influence of drugs or alcohol. |
| | | 10. Maintain machine carefully to prevent accidents. |
| Manufactured for Grizzly in Taiwan | | |

For your convenience, we post all available manuals and manual updates for free on our website at www.grizzly.com. Any updates to your model of machine will be reflected in these documents as soon as they are complete.

Contact Info

We stand behind our machines. If you have any questions or need help, use the information below to contact us. Before contacting, please get the serial number and manufacture date of your machine. This will help us help you faster.

Grizzly Technical Support
1203 Lycoming Mall Circle
Muncy, PA 17756
Phone: (570) 546-9663
Email: techsupport@grizzly.com

We want your feedback on this manual. What did you like about it? Where could it be improved? Please take a few minutes to give us feedback.

Grizzly Documentation Manager
P.O. Box 2069
Bellingham, WA 98227-2069
Email: manuals@grizzly.com





MACHINE DATA SHEET

Customer Service #: (570) 546-9663 · To Order Call: (800) 523-4777 · Fax #: (800) 438-5901

MODEL G0477 15" PLANER / MOULDER

Product Dimensions:

Weight..... 168 lbs.
 Width (side-to-side) x Depth (front-to-back) x Height..... 31 x 41 x 57-3/4 in.
 Footprint (Length x Width)..... 31 x 25-1/3 in.

Shipping Dimensions:

Type..... Cardboard Box
 Content..... Machine
 Weight..... 181 lbs.
 Length x Width x Height..... 23 x 36 x 27 in.
 Must Ship Upright..... Yes

Electrical:

Power Requirement..... 110V, Single-Phase, 60 Hz
 Prewired Voltage..... 110V
 Full-Load Current Rating..... 12A
 Minimum Circuit Size..... 15A
 Connection Type..... Cord & Plug
 Power Cord Included..... Yes
 Power Cord Length..... 7 ft.
 Power Cord Gauge..... 14 AWG
 Plug Included..... Yes
 Switch Type..... Paddle Safety Switch w/Removable Key

Motors:

Main

Type..... Universal
 Horsepower..... 2.5 HP
 Phase..... Single-Phase
 Amps..... 12A
 Speed..... 16,500 RPM
 Power Transfer..... V-Belt Drive
 Bearings..... Shielded & Permanently Lubricated



Main Specifications:

Operation Info

| | |
|---|------------|
| Max. Cut Width..... | 15 in. |
| Max. Cut Height..... | 6 in. |
| Min. Stock Length..... | 17 in. |
| Min. Stock Thickness..... | 1/8 in. |
| Max. Stock Thickness..... | 6 in. |
| No. of Cuts Per Inch..... | 42, 83 |
| No. of Cuts Per Minute..... | 11,000 |
| Cutterhead Speed..... | 5500 RPM |
| Planing Feed Rate..... | 11, 22 FPM |
| Moulding Feed Rate..... | 11 FPM |
| Max. Cut Depth Planing Full Width..... | 1/16 in. |
| Max. Cut Depth Planing 6 Inch Wide Board..... | 3/32 in. |
| Max. Profile Depth Moulding..... | 7/8 in. |
| Max. Profile Width Moulding..... | 4-9/16 in. |

Cutterhead Info

| | |
|---------------------------|------------------|
| Cutterhead Type..... | 2 Knife |
| Cutterhead Dia..... | 3-15/64 in. |
| No. of Knives..... | 2 |
| Knife Type..... | Double Edged HSS |
| Knife Size Length..... | 15-1/2 in. |
| Knife Size Width..... | 5/8 in. |
| Knife Size Thickness..... | 5/64 in. |
| Knife Adjustment..... | Clamp Blocks |

Table Info

| | |
|-----------------------------------|------------|
| Table Movement..... | 6 in. |
| Table Bed Size Length..... | 16 in. |
| Table Bed Size Width..... | 15 in. |
| Table Bed Size Thickness..... | 11/32 in. |
| Floor To Table Height..... | 34 in. |
| Roller Ext Table Size Length..... | 15 in. |
| Roller Ext Table Size Width..... | 11-1/3 in. |

Construction

| | |
|--------------------------|-----------------|
| Table..... | Stainless Steel |
| Body..... | Aluminum |
| Stand..... | Steel |
| Cutterhead Assembly..... | Steel |
| Infeed Roller..... | Rubber |
| Outfeed Roller..... | Rubber |
| Paint..... | Powder Coated |

Other

| | |
|------------------------|---------------|
| Measurement Scale..... | Inch & Metric |
| No. of Dust Ports..... | 1 |
| Dust Port Size..... | 2-1/2 in. |
| Mobile Base..... | D2058A |

Other Specifications:

| | |
|---|--------------------------|
| Country Of Origin | China |
| Warranty | 1 Year |
| Approximate Assembly & Setup Time | 1 Hour |
| Serial Number Location | ID Label on Left Housing |
| ISO 9001 Factory | No |
| CSA Certified | No |



SECTION 1: SAFETY

For Your Own Safety, Read Instruction Manual Before Operating This Machine

The purpose of safety symbols is to attract your attention to possible hazardous conditions. This manual uses a series of symbols and signal words intended to convey the level of importance of the safety messages. The progression of symbols is described below. Remember that safety messages by themselves do not eliminate danger and are not a substitute for proper accident prevention measures. Always use common sense and good judgment.



Indicates an imminently hazardous situation which, if not avoided, **WILL** result in death or serious injury.



Indicates a potentially hazardous situation which, if not avoided, **COULD** result in death or serious injury.



Indicates a potentially hazardous situation which, if not avoided, **MAY** result in minor or moderate injury. It may also be used to alert against unsafe practices.

NOTICE

This symbol is used to alert the user to useful information about proper operation of the machine.

Safety Instructions for Machinery

WARNING

OWNER'S MANUAL. Read and understand this owner's manual **BEFORE** using machine.

TRAINED OPERATORS ONLY. Untrained operators have a higher risk of being hurt or killed. Only allow trained/supervised people to use this machine. When machine is not being used, disconnect power, remove switch keys, or lock-out machine to prevent unauthorized use—especially around children. Make workshop kid proof!

DANGEROUS ENVIRONMENTS. Do not use machinery in areas that are wet, cluttered, or have poor lighting. Operating machinery in these areas greatly increases the risk of accidents and injury.

MENTAL ALERTNESS REQUIRED. Full mental alertness is required for safe operation of machinery. Never operate under the influence of drugs or alcohol, when tired, or when distracted.

ELECTRICAL EQUIPMENT INJURY RISKS. You can be shocked, burned, or killed by touching live electrical components or improperly grounded machinery. To reduce this risk, only allow qualified service personnel to do electrical installation or repair work, and always disconnect power before accessing or exposing electrical equipment.

DISCONNECT POWER FIRST. Always disconnect machine from power supply **BEFORE** making adjustments, changing tooling, or servicing machine. This prevents an injury risk from unintended startup or contact with live electrical components.

EYE PROTECTION. Always wear ANSI-approved safety glasses or a face shield when operating or observing machinery to reduce the risk of eye injury or blindness from flying particles. Everyday eyeglasses are not approved safety glasses.



WARNING

WEARING PROPER APPAREL. Do not wear clothing, apparel or jewelry that can become entangled in moving parts. Always tie back or cover long hair. Wear non-slip footwear to avoid accidental slips, which could cause loss of workpiece control.

HAZARDOUS DUST. Dust created while using machinery may cause cancer, birth defects, or long-term respiratory damage. Be aware of dust hazards associated with each workpiece material, and always wear a NIOSH-approved respirator to reduce your risk.

HEARING PROTECTION. Always wear hearing protection when operating or observing loud machinery. Extended exposure to this noise without hearing protection can cause permanent hearing loss.

REMOVE ADJUSTING TOOLS. Tools left on machinery can become dangerous projectiles upon startup. Never leave chuck keys, wrenches, or any other tools on machine. Always verify removal before starting!

INTENDED USAGE. Only use machine for its intended purpose and never make modifications not approved by Grizzly. Modifying machine or using it differently than intended may result in malfunction or mechanical failure that can lead to serious personal injury or death!

AWKWARD POSITIONS. Keep proper footing and balance at all times when operating machine. Do not overreach! Avoid awkward hand positions that make workpiece control difficult or increase the risk of accidental injury.

CHILDREN & BYSTANDERS. Keep children and bystanders at a safe distance from the work area. Stop using machine if they become a distraction.

GUARDS & COVERS. Guards and covers reduce accidental contact with moving parts or flying debris. Make sure they are properly installed, undamaged, and working correctly.

FORCING MACHINERY. Do not force machine. It will do the job safer and better at the rate for which it was designed.

NEVER STAND ON MACHINE. Serious injury may occur if machine is tipped or if the cutting tool is unintentionally contacted.

STABLE MACHINE. Unexpected movement during operation greatly increases risk of injury or loss of control. Before starting, verify machine is stable and mobile base (if used) is locked.

USE RECOMMENDED ACCESSORIES. Consult this owner's manual or the manufacturer for recommended accessories. Using improper accessories will increase the risk of serious injury.

UNATTENDED OPERATION. To reduce the risk of accidental injury, turn machine **OFF** and ensure all moving parts completely stop before walking away. Never leave machine running while unattended.

MAINTAIN WITH CARE. Follow all maintenance instructions and lubrication schedules to keep machine in good working condition. A machine that is improperly maintained could malfunction, leading to serious personal injury or death.

CHECK DAMAGED PARTS. Regularly inspect machine for any condition that may affect safe operation. Immediately repair or replace damaged or mis-adjusted parts before operating machine.

MAINTAIN POWER CORDS. When disconnecting cord-connected machines from power, grab and pull the plug—NOT the cord. Pulling the cord may damage the wires inside. Do not handle cord/plug with wet hands. Avoid cord damage by keeping it away from heated surfaces, high traffic areas, harsh chemicals, and wet/damp locations.

EXPERIENCING DIFFICULTIES. If at any time you experience difficulties performing the intended operation, stop using the machine! Contact our Technical Support at (570) 546-9663.



WARNING

Additional Safety for Planer/Moulders

1. **INSTRUCTION MANUAL.** This machine presents significant safety hazards to untrained users. Read/understand this entire manual before starting the planer.
2. **REACHING INSIDE PLANER/MOULDER.** Never reach inside planer or remove covers when the planer is connected to power.
3. **INFEED CLEARANCE SAFETY.** The infeed roller is designed to pull material into the cutterhead. Always keep hands, clothing, and long hair away from the infeed roller during operation to prevent serious injury.
4. **BODY POSITION WHILE OPERATING.** The workpiece may kick out during operation. To avoid getting hit, stand to the side of the planer during the entire operation.
5. **PLANING CORRECT MATERIAL.** Only plane natural wood stock with this planer/moulder. DO NOT plane MDF, plywood, laminates, or other synthetic products.
6. **GRAIN DIRECTION.** Planing or moulding across the grain is hard on the planer/moulder and may cause the workpiece to kick out. Always plane in the same direction or at a slight angle with the wood grain.
7. **LOOKING INSIDE PLANER/MOULDER.** Wood chips fly around inside the planer/moulder at a high rate of speed. DO NOT look inside the planer/moulder or remove guards/covers during operation.
8. **CUTTING LIMITATIONS.** The planer/moulder may kick out a workpiece at the operator or be damaged if pushed beyond these limits.
 - Maximum Depth of Cut (6 in.)..... $\frac{3}{32}$ "
 - Maximum Depth of Cut (full width) ... $\frac{1}{16}$ "
 - Minimum Board Length..... 17"
 - Minimum Board Thickness $\frac{1}{8}$ "
 - Maximum # of Boards at One Time..... 1
9. **CLEAN STOCK.** Planing or moulding stock with nails, staples, or loose knots MAY cause debris to kick out at the operator and WILL damage your cutters when they contact the cutterhead. Always thoroughly inspect and prepare stock to avoid these hazards.
10. **REMOVING JAMMED WORKPIECES.** To avoid serious injury, always stop the planer/moulder and disconnect power before removing jammed workpieces.
11. **DULL/DAMAGED CUTTERS.** The planer/moulder may kick out a workpiece at the operator or give poor finish results if it is operated with dull or damaged cutters.
12. **UNPLUGGING DURING ADJUSTMENTS.** When connected to power, the planer/moulder can be accidentally turned **ON**. Always disconnect power when servicing or adjusting the components of the planer/moulder.
12. **WORKPIECE CLEARANCE.** Always verify workpiece has enough room to exit the planer/moulder before starting.

WARNING

Like all machinery there is potential danger when operating this machine. Accidents are frequently caused by lack of familiarity or failure to pay attention. Use this machine with respect and caution to lessen the possibility of operator injury. If normal safety precautions are overlooked or ignored, serious personal injury may occur.

CAUTION

No list of safety guidelines can be complete. Every shop environment is different. Always consider safety first, as it applies to your individual working conditions. Use this and other machinery with caution and respect. Failure to do so could result in serious personal injury, damage to equipment, or poor work results.



SECTION 2: POWER SUPPLY

Availability

Before installing the machine, consider the availability and proximity of the required power supply circuit. If an existing circuit does not meet the requirements for this machine, a new circuit must be installed. To minimize the risk of electrocution, fire, or equipment damage, installation work and electrical wiring must be done by an electrician or qualified service personnel in accordance with all applicable codes and standards.

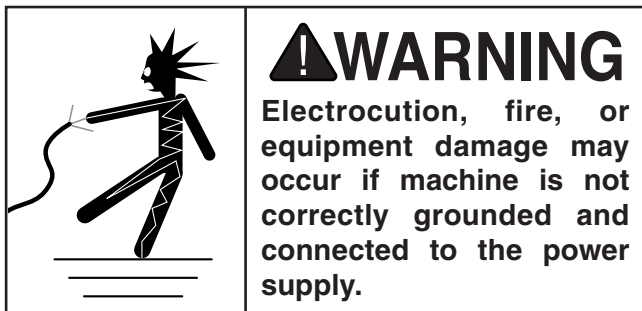

Full-Load Current Rating

The full-load current rating is the amperage a machine draws at 100% of the rated output power. On machines with multiple motors, this is the amperage drawn by the largest motor or sum of all motors and electrical devices that might operate at one time during normal operations.

Full-Load Current Rating at 110V..... 12A

The full-load current is not the maximum amount of amps that the machine will draw. If the machine is overloaded, it will draw additional amps beyond the full-load rating.

If the machine is overloaded for a sufficient length of time, damage, overheating, or fire may result—especially if connected to an undersized circuit. To reduce the risk of these hazards, avoid overloading the machine during operation and make sure it is connected to a power supply circuit that meets the requirements in the following section.

Circuit Requirements

This machine is prewired to operate on a 110V power supply circuit that has a verified ground and meets the following requirements:

Nominal Voltage 110V/120V
Cycle.....60 Hz
Phase..... Single-Phase
Minimum Circuit Size 15 Amps

A power supply circuit includes all electrical equipment between the breaker box or fuse panel in the building and the machine. The power supply circuit used for this machine must be sized to safely handle the full-load current drawn from the machine for an extended period of time. (If this machine is connected to a circuit protected by fuses, use a time delay fuse marked D.)



Note: *The circuit requirements listed in this manual apply to a dedicated circuit—where only one machine will be running at a time. If this machine will be connected to a shared circuit where multiple machines will be running at the same time, consult a qualified electrician to ensure that the circuit is properly sized for safe operation.*



Grounding & Plug Requirements

This machine **MUST** be grounded. In the event of certain malfunctions or breakdowns, grounding reduces the risk of electric shock by providing a path of least resistance for electric current.

This machine is equipped with a power cord that has an equipment-grounding wire and a grounding plug (similar to the figure below). The plug must only be inserted into a matching receptacle (outlet) that is properly installed and grounded in accordance with all local codes and ordinances.

⚠ WARNING

Serious injury could occur if you connect the machine to power before completing the setup process. DO NOT connect to power until instructed later in this manual.

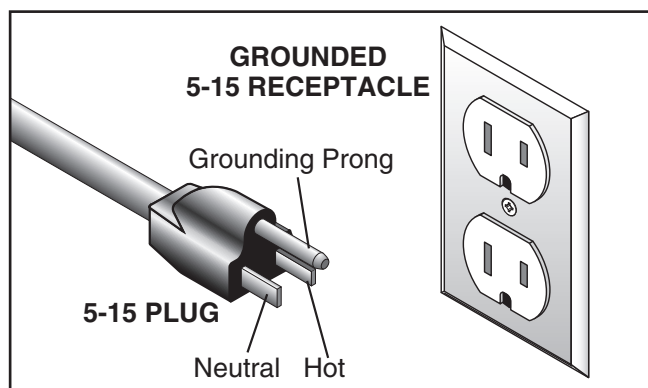

Figure 2. Typical 5-15 plug and receptacle.

⚠ CAUTION

SHOCK HAZARD!
Two-prong outlets do not meet the grounding requirements for this machine. Do not modify or use an adapter on the plug provided—if it will not fit the outlet, have a qualified electrician install the proper outlet with a verified ground.

Improper connection of the equipment-grounding wire can result in a risk of electric shock. The wire with green insulation (with or without yellow stripes) is the equipment-grounding wire. If repair or replacement of the power cord or plug is necessary, do not connect the equipment-grounding wire to a live (current carrying) terminal.

Check with a qualified electrician or service personnel if you do not understand these grounding requirements, or if you are in doubt about whether the tool is properly grounded. If you ever notice that a cord or plug is damaged or worn, disconnect it from power, and immediately replace it with a new one.

Extension Cords

We do not recommend using an extension cord with this machine. If you must use an extension cord, only use it if absolutely necessary and only on a temporary basis.

Extension cords cause voltage drop, which may damage electrical components and shorten motor life. Voltage drop increases as the extension cord size gets longer and the gauge size gets smaller (higher gauge numbers indicate smaller sizes).

Any extension cord used with this machine must contain a ground wire, match the required plug and receptacle, and meet the following requirements:

Minimum Gauge Size 14 AWG
Maximum Length (Shorter is Better)..... 50 ft.



SECTION 3: SET UP

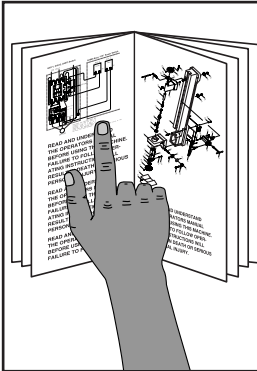

!WARNING

This machine presents serious injury hazards to untrained users. Read through this entire manual to become familiar with the controls and operations before starting the machine!

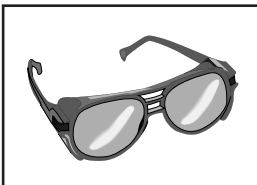

!WARNING

Wear safety glasses during the entire setup process!

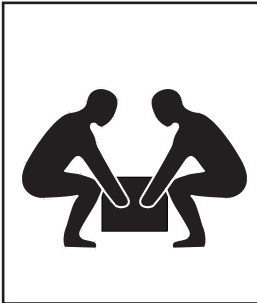

!WARNING

This machine and its components are very heavy. Get lifting help or use power lifting equipment such as a forklift to move heavy items.

Items Needed for Set Up

The following items are needed to complete the set up process, but are not included with your machine:

| Description | Qty |
|--|-----|
| • Safety Glasses (for each person) | 1 |
| • Hex Wrench 4mm | 1 |
| • Open-End Wrench 13mm or 1/2" | 1 |
| • Open-End Wrench 14mm | 1 |

Unpacking

Your machine was carefully packaged for safe transportation. Remove the packaging materials from around your machine and inspect it. If you discover any damage, *please call us immediately at (570) 546-9663 for advice.*

Save the containers and all packing materials for possible inspection by the carrier or its agent. *Otherwise, filing a freight claim can be difficult.*

When you are completely satisfied with the condition of your shipment, inventory the contents.

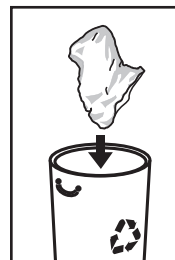

!WARNING

SUFFOCATION HAZARD!

Keep children and pets away from plastic bags or packing materials shipped with this machine. Discard immediately.



Inventory

The following is a list of items shipped with your machine. Before beginning setup, lay these items out and inventory them.

If any non-proprietary parts are missing (e.g. a nut or a washer), we will gladly replace them; or for the sake of expediency, replacements can be obtained at your local hardware store.

| Inventory (Figure 3) | Qty |
|------------------------------------|-----|
| A. Long Frames | 2 |
| B. Short Frames..... | 2 |
| C. Plain Legs..... | 2 |
| D. Notched Legs | 2 |
| E. Long Braces | 2 |
| F. Short Braces | 2 |
| G. Planer/moulder (not shown)..... | 1 |

Components and Hardware (not shown)

- Roller Adjustment Wrench..... 1
- Open-End Wrench 8/10mm..... 1
- Rubber Grip Magnets.....2
- Hex Wrench 4mm..... 1
- Dust Chute
- Dust Chute Adapter..... 1
- Dust Collection Bag..... 1
- Bag Clamp..... 1
- Cap Screw M6-1 x 25..... 1
- Button Head Cap Screw M6-1 x 25
- Crank Handle
- Handle Plug..... 1
- Phillips Head Screw M6-1 x 25
- Cap Screws #10-32 x 2³/₈"
- Flat Washers #10..... 2
- Wing Screws 1/4-20 x 1¹/₄"
- Flat Washers 1/4"
- Threaded Guide Inserts
- Hex Bolts M8-1.25 x 80 (Stand)
- Flat Washers 8mm (Stand)
- Hex Nuts M8-1.25 (Stand)..... 4
- Carriage Bolts 5/16-18 x 3/4" (Stand)
- Flange Nuts 5/16-18 (Stand)..... 24

NOTICE

If you cannot find an item on this list, carefully check around/inside the machine and packaging materials. Often, these items get lost in packaging materials while unpacking or they are pre-installed at the factory.

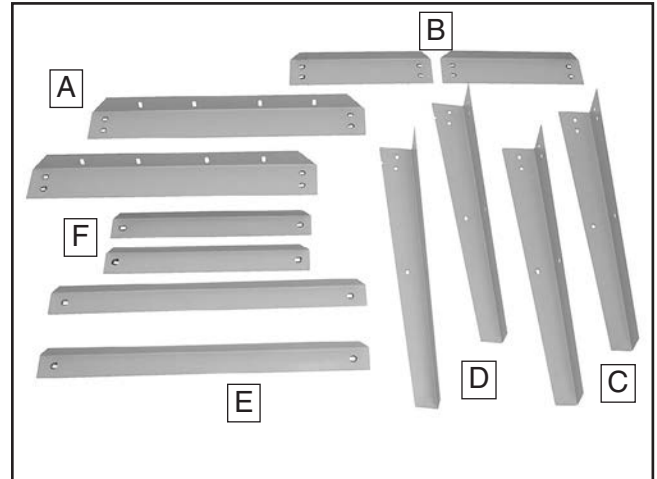
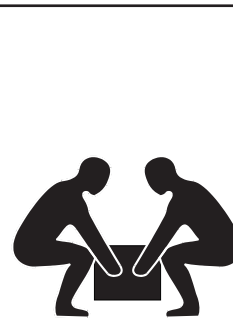

Figure 3. G0477 Inventory.



WARNING

The Model G0477 is a very heavy machine. Serious personal injury may occur if safe moving methods are not followed. To be safe, you will need assistance when moving the shipping box and removing the machine from the box.



Clean Up

The unpainted surfaces are coated with a waxy oil to protect them from corrosion during shipment. Remove this protective coating with a solvent cleaner or citrus-based degreaser such as Grizzly's G7895 Degreaser. To clean thoroughly, some parts may need to be removed. **For optimum performance from your machine, make sure you clean all moving parts or sliding contact surfaces that are coated.** Avoid chlorine-based solvents, such as acetone or brake parts cleaner, as they may damage painted surfaces should they come in contact. Always follow the manufacturer's instructions when using any type of cleaning product.

| | |
|--|---|
|  | <p>⚠ WARNING Gasoline and petroleum products have low flash points and could cause an explosion or fire if used to clean machinery. DO NOT use gasoline or petroleum products to clean the machinery.</p> |
|--|---|

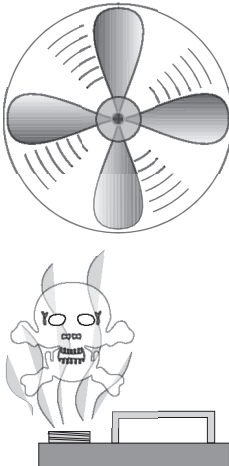
| | |
|---|---|
|  | <p>⚠ CAUTION Many of the solvents commonly used to clean machinery can be toxic when inhaled or ingested. Lack of ventilation while using these solvents could cause serious personal health risks or fire. Take precautions from this hazard by only using cleaning solvents in a well ventilated area.</p> |
|---|---|

Site Considerations

Floor Load

Refer to the **Machine Data Sheet** for the weight and footprint specifications of your machine. Some floors may require additional reinforcement to support both the machine and operator.

Working Clearances

Consider existing and anticipated needs, size of material to be processed through each machine, and space for auxiliary stands, work tables or other machinery when establishing a location for your new machine. See **Figure 4** for the minimum working clearances.

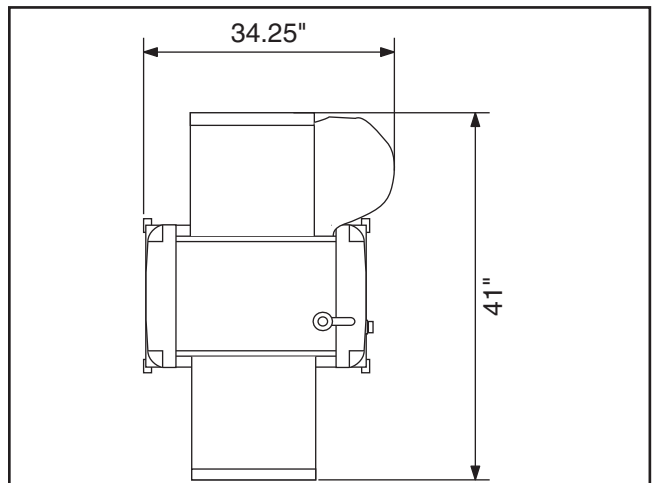

Figure 4. Minimum working clearances.

| | |
|--|---|
|  | <p>⚠ CAUTION Unsupervised children and visitors inside your shop could cause serious personal injury to themselves. Lock all entrances to the shop when you are away and DO NOT allow unsupervised children or visitors in your shop at any time!</p> |
|--|---|



Stand Assembly

The stand for the Model G0477 must be assembled before the planer/moulder can be mounted on it. It may be helpful to refer to the **Stand Breakdown** on **Page 36** during this procedure.

| Components and Hardware Needed: | Qty |
|---|------------|
| Notched Legs* | 2 |
| Plain Legs..... | 2 |
| Long Frame Pieces | 2 |
| Short Frame Pieces..... | 2 |
| Long Braces | 2 |
| Short Braces..... | 2 |
| Carriage Bolts $\frac{5}{16}$ -18 x $\frac{3}{4}$ " | 24 |
| Flange Nuts $\frac{5}{16}$ -18..... | 24 |

* These stand legs each have a small, semicircular notch towards to top of the leg, as shown in **Figure 5**.

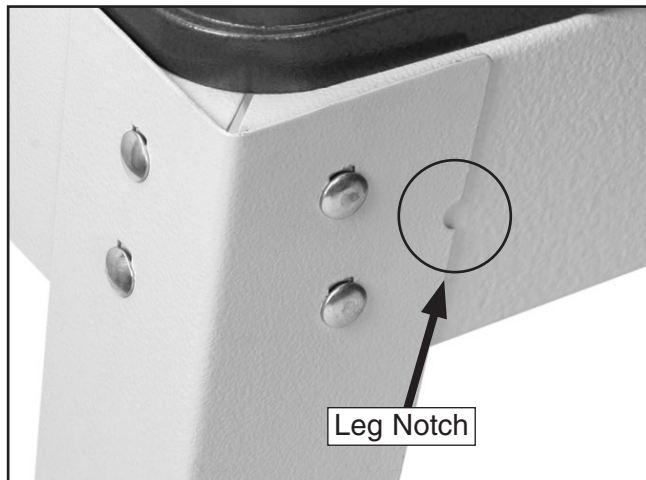

Figure 5. Leg notches.

To assemble the stand:

1. Place a plain leg and a notched leg side-by-side on the ground, with the double bolt holes of the legs towards the top. The notched leg should be on the right of the unmarked leg.
2. Fasten a short frame piece to the legs using $\frac{5}{16}$ -18 x $\frac{3}{4}$ " carriage bolts and flange nuts.
3. Fasten a short brace piece to the legs, using carriage bolts and flange nuts.

4. Repeat **Steps 1–3** for the other side of the stand. The finished halves of the stand should look like those shown in **Figure 6**.

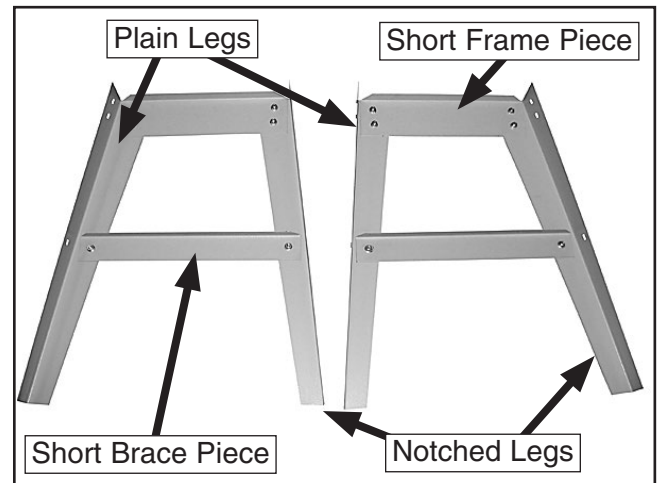

Figure 6. Stand halves.

5. Fasten the stand halves together using a long frame piece, a long brace piece, carriage bolts and flange nuts as shown in **Figure 7**.

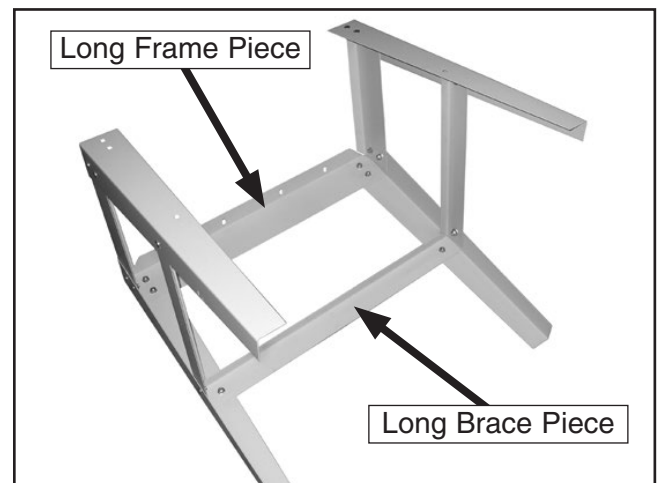

Figure 7. Joining stand halves.

6. Fasten the remaining long frame piece and long brace piece to the stand using carriage bolts and hex nuts.



Mounting Planer/ Moulder on Stand



Components and Hardware Needed:

| | |
|------------------------------|---|
| Hex Bolts M8-1.25 x 80 | 4 |
| Flat Washers 8mm | 8 |
| Hex Nuts M8-1.25 | 4 |

To mount the planer/moulder to the stand:

1. Position the assembled stand so that it is on a flat, level surface and is clear of nearby equipment or other obstructions.
2. With the help of an assistant, lift the planer/moulder onto the stand.
3. Align the mounting holes in the base casting of the planer/moulder with the mounting holes in the stand, as shown in **Figure 8**.

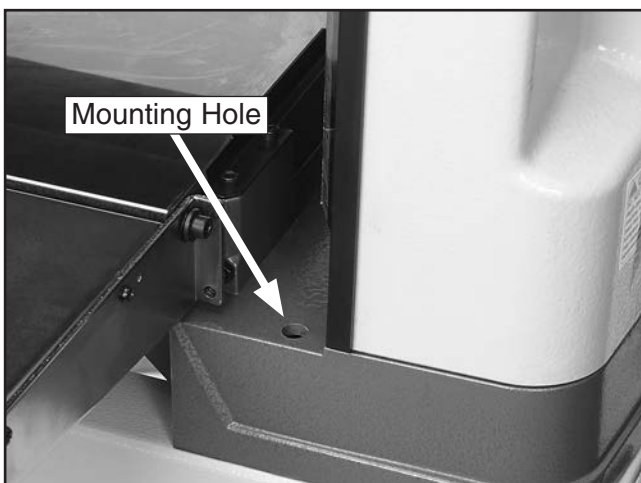

Figure 8. Mounting holes in base casting.

4. Fasten the planer/moulder to the stand using the M8-1.25 x 80 hex bolts, flat washers and hex nuts.

Dust Chute and Bag

! CAUTION

DO NOT operate the Model G0477 without the dust collection bag installed. This planer/moulder creates substantial amounts of wood dust while operating. Failure to use the dust collection bag can result in short and long-term respiratory illness.

Components and Hardware Needed: Qty

| | |
|---------------------------------------|---|
| Dust Chute | 1 |
| Button Head Cap Screw M6-1 x 25 | 1 |
| Dust Collection Bag..... | 1 |
| Bag Clamp..... | 1 |
| Dust Chute Adapter..... | 1 |
| Cap Screw M6-1 x 25..... | 1 |

To install the dust chute and bag:

1. Fasten the dust chute on the fan cover using the button head cap screw.
2. Fit the dust chute adapter over the dust chute and fasten in place using the cap screw.
3. Slip the bag clamp over the neck of the bag, and fit the bag opening onto the dust chute adapter.
4. Close the clamp to fasten the bag onto the dust chute adapter.
5. Give the bag a slight tug to ensure it is secured tightly.

Note: If the clamp seems to be too loose or too tight when the clamp is engaged, it can be adjusted by rotating the clamping handle. Rotate the clamping handle clockwise to tighten the clamp or counterclockwise to loosen the clamp.



Crank Handle

| Components and Hardware Needed | Qty |
|--------------------------------|-----|
| Cap Screw M5-.8 x 25..... | 1 |

To install the crank handle (Figure 9):

1. Slide the handle onto the handle shaft located at the front of the right housing cap.
2. Fasten with the cap screw.



Figure 9. Crank handle installed.

Test Run

Once the assembly is complete, test run your machine to make sure it runs properly.

If, during the test run, you cannot easily locate the source of an unusual noise or vibration, stop using the machine immediately, then review the **Troubleshooting on Page 26**.

If you still cannot remedy a problem, contact our Tech Support at (570) 546-9663 for assistance.

To test run the machine:

1. Connect the machine to the power source.
2. Make sure you have read the safety instructions at the beginning of the manual and that the machine is setup properly.
3. Make sure all tools and objects used during set up are cleared away from the machine.
4. Turn the machine **ON**.
5. Listen to and watch for abnormal noises or actions. The machine should run smoothly with little or no vibration or rubbing noises.

—Strange or unusual noises should be investigated and corrected before operating the machine further. Always disconnect the machine from power when investigating or correcting potential problems.



SECTION 4: OPERATIONS

Operation Safety

!WARNING

Damage to your eyes, lungs, and ears could result from using this machine without proper protective gear. Always wear safety glasses, a respirator, and hearing protection when operating this machine.

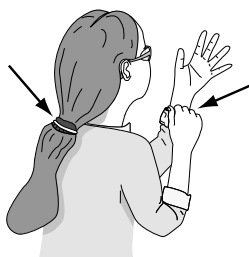
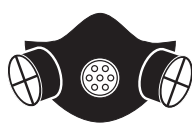

!WARNING

Loose hair and clothing could get caught in machinery and cause serious personal injury. Keep loose clothing and long hair away from moving machinery.

NOTICE

If you have never used this type of machine or equipment before, WE STRONGLY RECOMMEND that you read books, trade magazines, or get formal training before beginning any projects. Regardless of the content in this section, Grizzly Industrial will not be held liable for accidents caused by lack of training.

Safety Switch Key

To prevent the machine from starting, remove the lockout key (**Figure 10**) from the paddle switch.

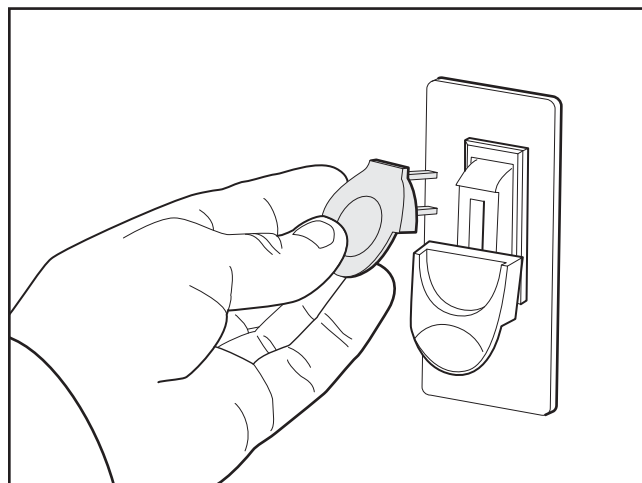

Figure 10. Removing key to disable switch.

Basic Operation

The basic steps of operating the planer/moulder are as follows:

1. Put on safety glasses, ear protection and a respirator.
2. Unless your workpiece starts very flat, surface plane the workpiece on a jointer until it is flat.
3. Adjust the headstock height (see **Page 19**) so that the planing knives are slightly lower than your workpiece height to ensure the first cut is as light as possible.
4. Start the planer/moulder.
5. Place the flat side of the board down on the table, and feed the workpiece through the planer/moulder, making sure not to stand directly in front or behind the workpiece.

Note: If the cut is too heavy and bogs down the planer/moulder, turn the planer/moulder **OFF** immediately, allow it to come to a complete stop, remove the workpiece, and repeat Steps 3–5.

6. Measure your workpiece thickness and adjust the headstock height as necessary to take a lighter or heavier pass, depending on your needs.

Operation Tips

- Inspect lumber for defects, warping, cupping, twisting, and for foreign objects (nails, staples, imbedded gravel, etc.). If you have any question about the quality of your lumber, do not use it. Remember, wood stacked on a concrete floor can have small pieces of stone or concrete pressed into the surface.
- Use the full width of the planer/moulder. Alternate between the left, the right, and the middle when feeding lumber into the planer/moulder. Your cutters will remain sharp much longer.
- Scrape all glue off joined boards before planing.
- Plane **ONLY** natural wood fiber. **DO NOT** plane MDF, plywood, laminates, or other synthetic products.
- Plane wood with the grain. Never feed end-cut or end-grained lumber into your planer/moulder.
- Do not use boards with loose or large knots, splits, crossgrain or other obvious blemishes or defects. They can damage the machine and pose the possibility of operator injury.
- Keep your work area clear.
- When making multiple passes on long stock, use the stock return rollers on the top of the machine to move the material back to the infeed side of the machine.

- Avoid planing wood with a high water content. Wood with more than 20% moisture content or wood exposed to excessive moisture (such as rain or snow), will plane poorly and cause excessive wear to the cutters and motor. Excess moisture can also hasten rust and corrosion of the planer/moulder and/or individual components.

Feed Speed

The infeed and outfeed rollers power the stock through the planer/moulder while keeping boards flat and providing a consistent rate of movement.

The power feed features 22 FPM and 11 FPM feed rates. The speed should be changed **ONLY** when the machine is running.

Figure 11 illustrates the three different positions of the feed control knob. Turning the knob clockwise sets the feed speed to 22 FPM (used for rough planing). Turning the knob counterclockwise sets the feed speed to 11 FPM (used for finishing and moulding). Turning the knob to the center position places the gearbox in neutral.

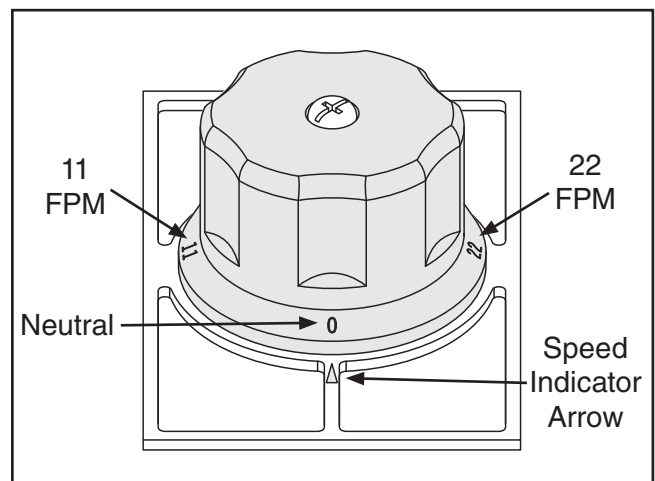

Figure 11. Feed control knob positions.

NOTICE

Change the speeds when the planer/moulder is running, but DO NOT attempt to change speeds during any cutting operations or damage to the gearbox will result.



Headstock Height Adjustment

The headstock height can be adjusted via the manual crank handle (used for fine adjustments) or by the power adjustment lever (used for larger headstock movements). The Model G0477 features a height scale (in both inches and millimeters) that shows the exact height of the headstock.

To change the headstock height manually:

1. Rotate the crank handle on the top of the planer/moulder clockwise to raise the headstock, or counterclockwise to lower the headstock. Each full turn of the crank handle equals $\frac{1}{16}$ " (1.59 mm).
2. Check the height scale at the front of the planer/moulder, shown in **Figure 12**, to ensure headstock height accuracy.

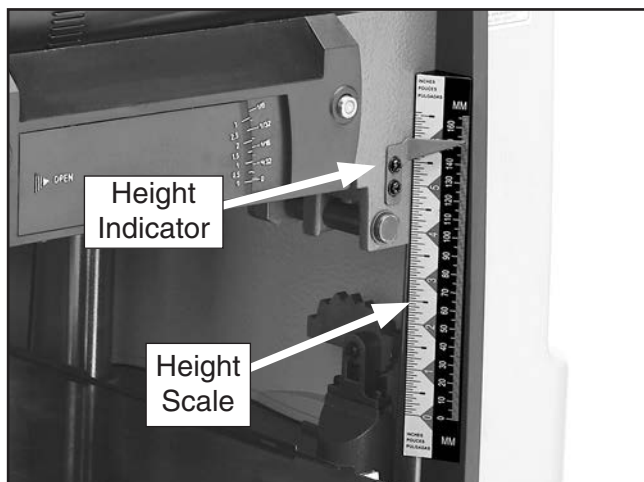

Figure 12. Headstock height scale.

To change the headstock height using the power adjustment lever (Figure 13):

1. While the machine is running, push the power adjustment lever up to raise the headstock, or push the lever down to lower the headstock.

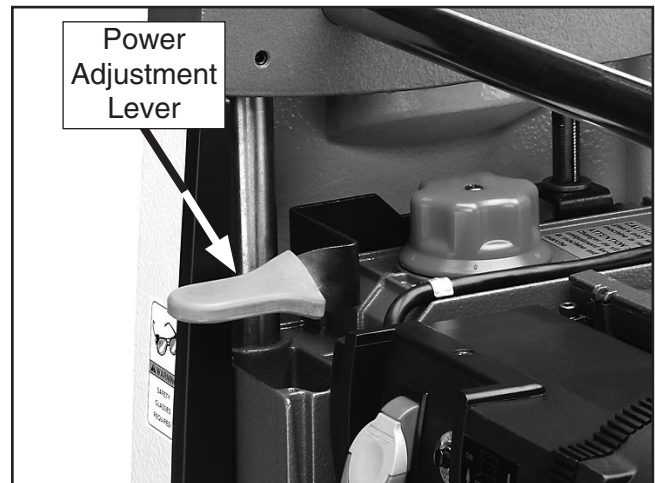

Figure 13. Power adjustment lever.

2. Check the height gauge at the front of the planer/moulder to ensure headstock height accuracy.

Preset Thickness Settings

The Model G0477 features a preset thickness knob, which prevents the headstock from moving any lower than the desired workpiece thickness.

To use the preset depth gauge (Figure 14):

1. Raise the headstock to allow room for the workpiece.
2. Set the desired workpiece thickness using the preset depth gauge.



Figure 14. Preset depth gauge.

- Place the workpiece below the depth-of-cut gauge, as shown in **Figure 15**.



Figure 15. Depth-of-cut gauge.

- Lower the headstock until it reaches the preset thickness. The headstock will not be able to move lower than the preset height.
- If the depth-of-cut gauge reads greater than $\frac{3}{32}$ " , repeat **Steps 1–4** with a larger thickness selected. We recommend making multiple, shallow passes for cuts deeper than $\frac{3}{32}$ " ($\frac{1}{16}$ " for workpieces 8"–15" wide).
- Remove the workpiece from the planer/moulder.
- Start the planer/moulder.
- Place the flat side of the board down on the table, and feed the workpiece through the planer/moulder, making sure not to stand directly in front or behind the workpiece.

Roller Height Adjustment

The Model G0477 features three infeed/outfeed roller height settings. The provided special wrench is used to turn the roller height adjuster, as shown in **Figure 16**.

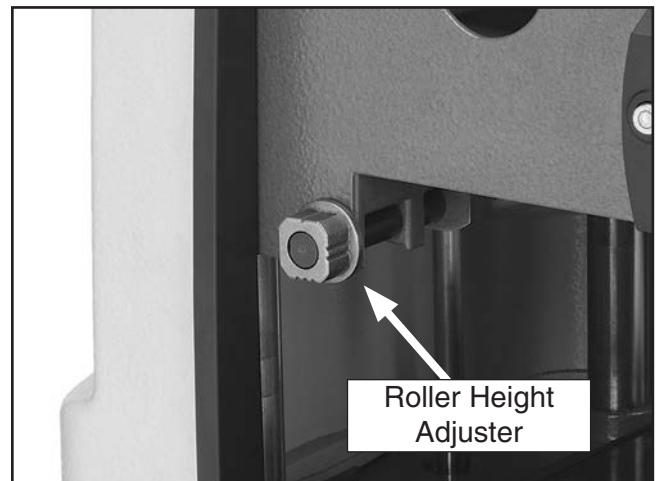

Figure 16. Roller height adjuster.

To adjust the infeed/outfeed roller height:

- UNPLUG THE PLANER/MOULDER FROM THE POWER SOURCE!
- Raise the headstock clear of the planer/moulder table.
- Use the special wrench provided to turn the roller height adjuster to one of the three preset settings shown in **Figure 17**.

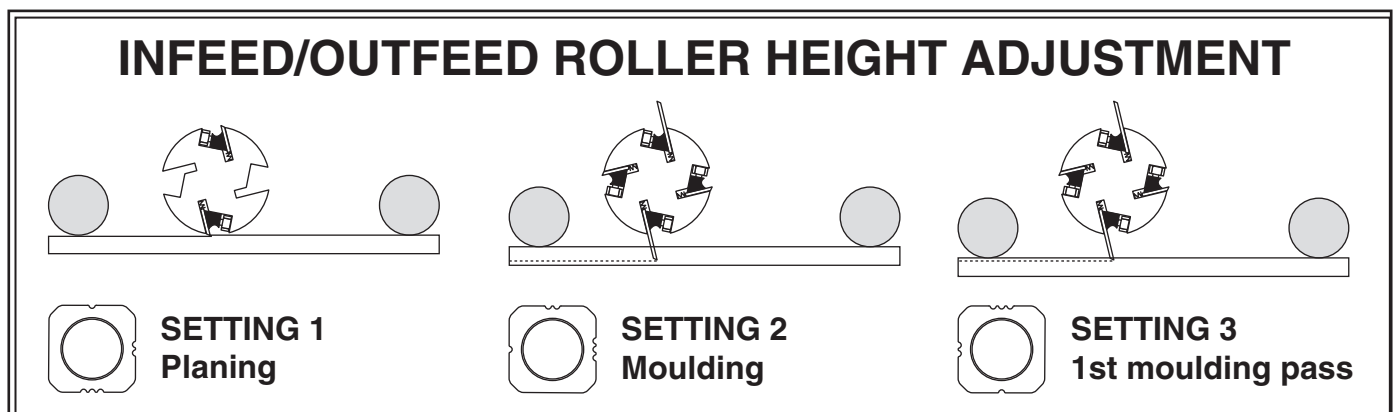

Figure 17. Roller height adjuster settings.

Moulding Knives

| | |
|----------------------|------------|
| Tools Needed: | Qty |
| Wrench 8mm | 1 |

The G0477 has two moulding knife slots. Each slot can accommodate two different moulding knives at the same time. However, both moulding knife slots must be set up identically for a successful moulding operation. The planing knives do not need to be removed when moulding.

To install/change the moulding knives on your planer/moulder:

1. UNPLUG THE PLANER/MOULDER FROM THE POWER SOURCE!
2. Push the cutterhead lock down, and rotate the cutterhead until the moulding knife slot is visible, as shown in **Figure 18**, then release the cutterhead lock and slightly rotate the cutterhead in either direction until it locks.

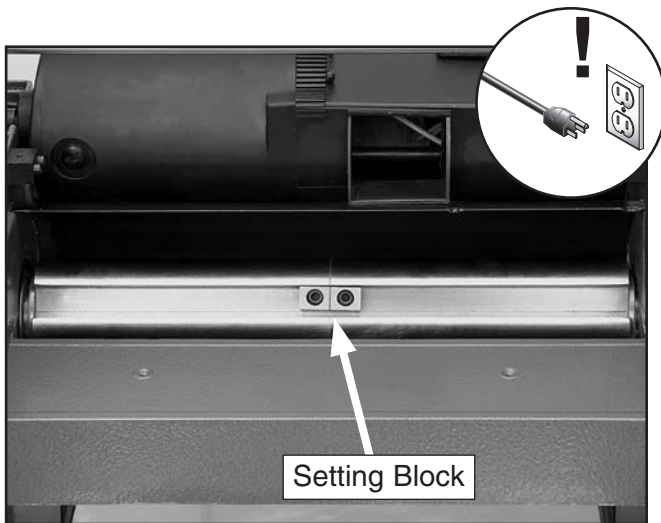

Figure 18. Moulding knife slot.

4. Ensure the moulding knife slot is clean and clear of dirt, dust and other debris.
5. With the gib bolts already inserted into the gib, place the gib in the moulding knife slot.

6. Slide the moulding knife up against the setting block.
7. Balance the opposite end of the gib using the provided spacers, as shown in **Figure 19**. Always ensure that the spacers used are the same width as the moulding knife.

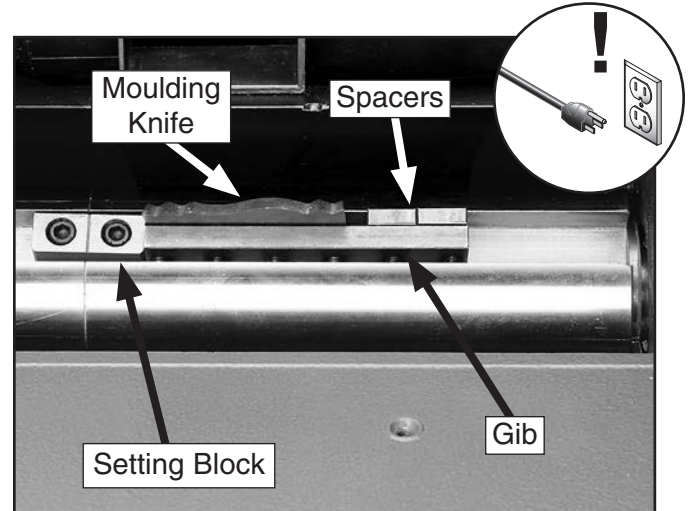

Figure 19. Moulding knife installation.

8. Tighten the gib bolts in the order indicated in **Figure 20**.

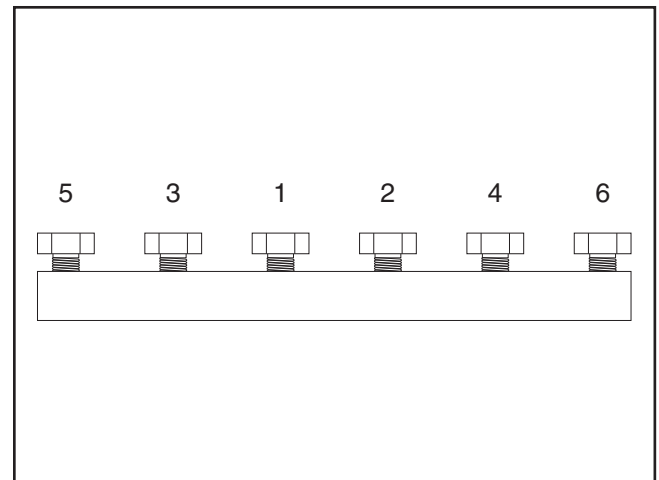

Figure 20. Gib bolt tightening sequence (moulding knives).

9. Repeat **Steps 2–8** to install one or more additional moulding knives.



Setting Up Moulding Fence Guide

| Components and Hardware Needed: | Qty |
|---------------------------------|-----|
| Wing Bolts 1/4-20 x 1 1/4"..... | 4 |
| Flat Washers 1/4"..... | 4 |
| Cap Screw M5-.8 x 60..... | 2 |
| Flat Washer 5mm..... | 2 |
| Guide Fence Clamp | 2 |

It is essential that you have a properly adjusted guide fence in place when moulding. **Figure 22** on **Page 23** features a plan for creating your own guide fence. We recommend using softwood or plywood for guide fence construction.

To fasten the guide fence to the planer/moulder:

1. UNPLUG THE PLANER/MOULDER FROM THE POWER SOURCE!
2. Ensure that the threaded inserts indicated in **Figure 22** on **Page 23** are firmly in place.
3. Raise the planer/moulder headstock to its maximum height to provide working room.
4. Hand-fasten the guide boards to the baseboard using the wing bolts and flat washers.
5. Fasten the baseboard to the table using the cap screws, flat washers and clamps, as shown in **Figure 21**.

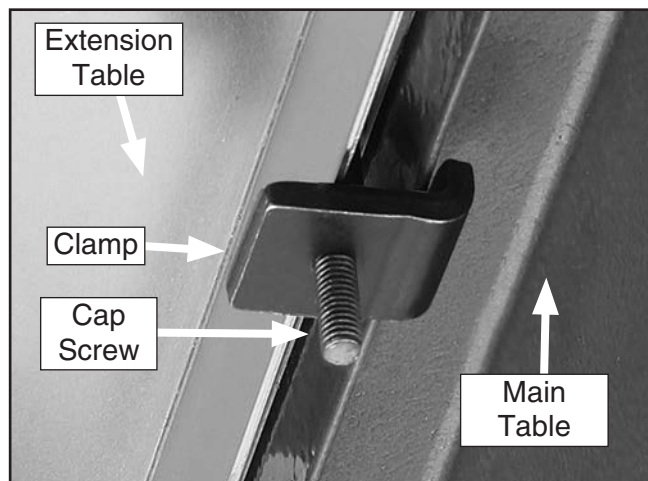

Figure 21. Clamp installation.

Adjusting Moulding Guide Fence

To adjust the guide fences to fit a workpiece:

1. UNPLUG THE PLANER/MOULDER FROM THE POWER SOURCE!
2. Place the workpiece flush against the center guide.
3. Adjust the guide boards to fit the workpiece, allowing for smooth and even workpiece movement throughout the guide fence.
4. Fully tighten the wing bolts to fasten the guide boards in place.

Edge Moulding

Certain moulding tasks require the workpiece to be oriented vertically, and thus extra-tall guide boards are needed. Follow the plan shown in **Figure 22** on **Page 23**, but increase the width of the center guide and the guide boards from 1/2" to 1".

To prepare the guide fence for edge moulding:

1. UNPLUG THE PLANER/MOULDER FROM THE POWER SOURCE!
2. Replace the center guide and guide boards with extra-tall guides.
3. Follow **Steps 2–4** of **Adjusting Moulding Guide Fence** on this page.

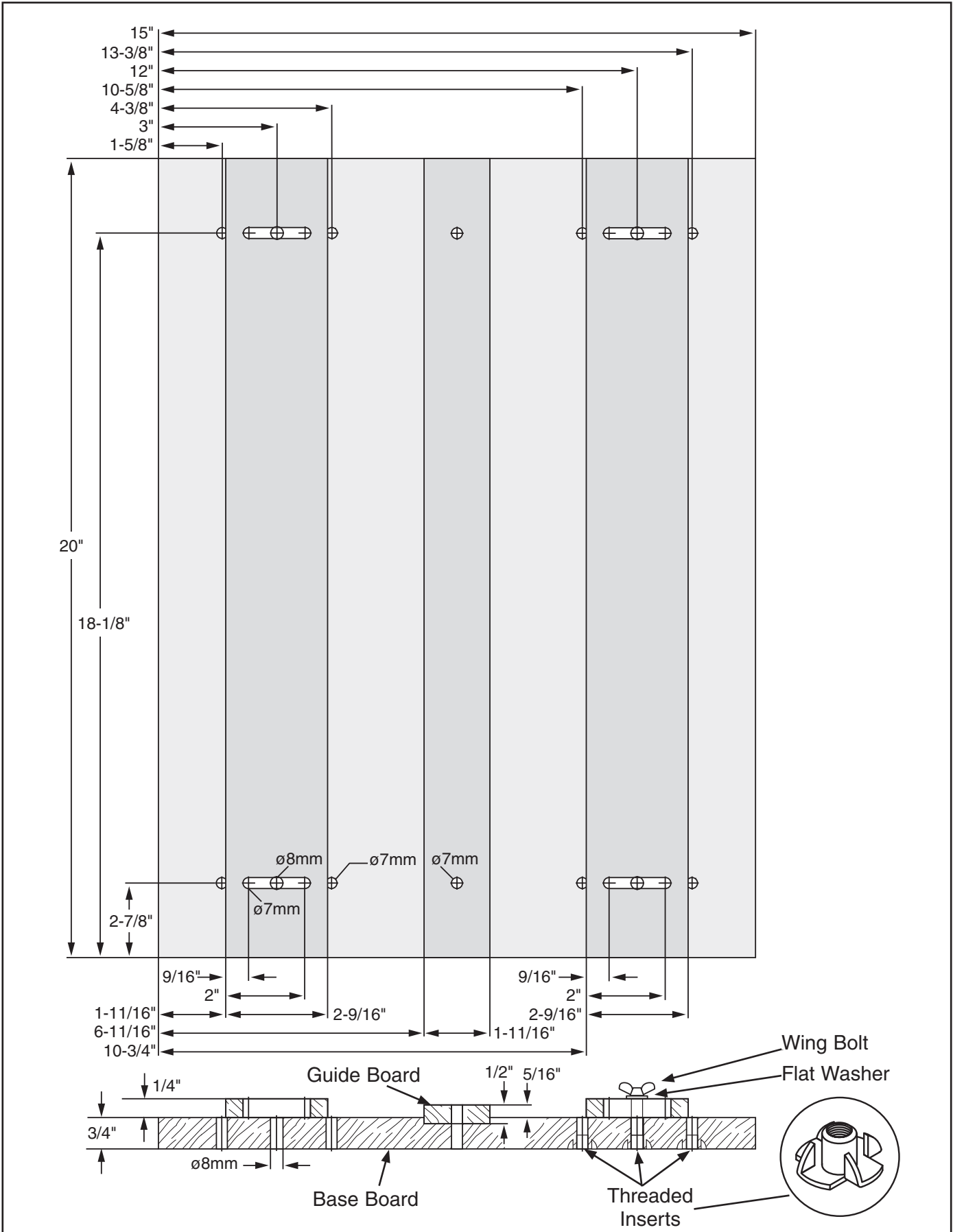

Figure 22. Guide Fence Plan (shown at approx. 30% size).



SECTION 5: ACCESSORIES

Moulding Knives

Select from this terrific assortment of casing, baseboard, crown moulding and detail cutters. Knives come in sets of three, so buy two sets and you'll get three changes of knives!

Call 1-800-523-4777 To Order



G4548

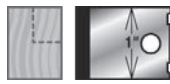

G4564



G4549



G4550



G4561



G4520



G4553



G4554



G4555



G4556



G4551

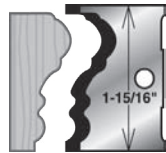

G4542



G4543

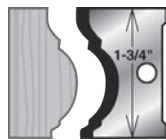

G4559



G4558

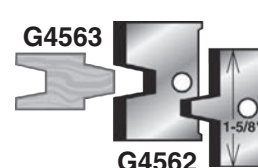

G4562

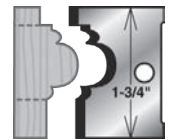

G4557



G4534

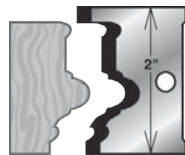

G4560

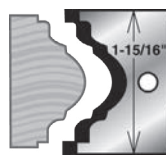

G4545

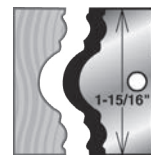

G4544

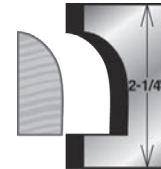

G4523

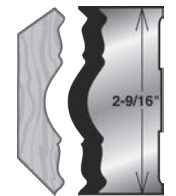

G4538

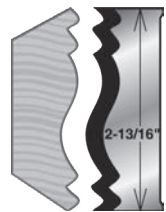

G4535

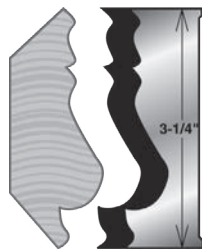

G4539



G4547

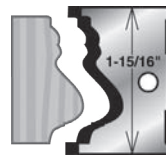

G4541

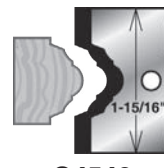

G4546

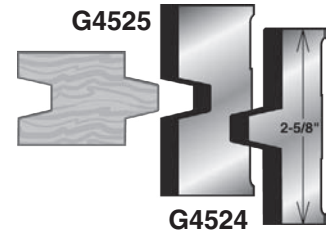

G4524

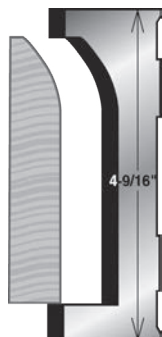

G4530

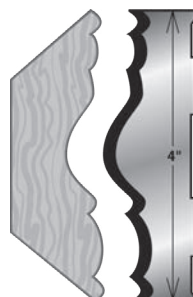

G4536

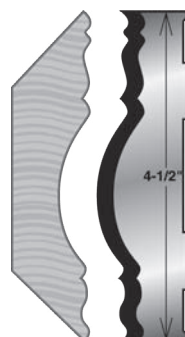

G4537

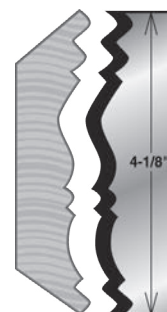

G4533

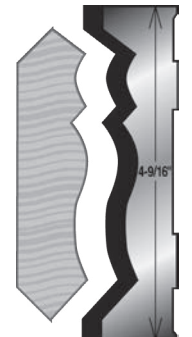

G4531



SECTION 6: MAINTENANCE

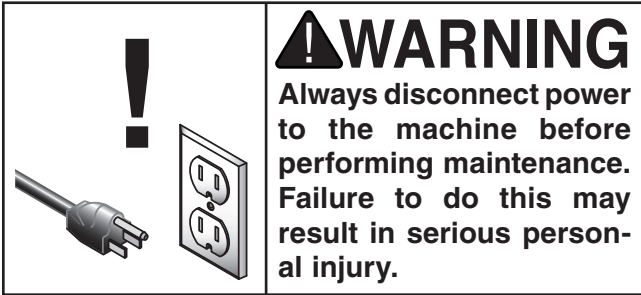

Schedule

For optimum performance from your machine, follow this maintenance schedule and refer to any specific instructions given in this section.

Daily Check/Maintenance:

- Tighten loose gib bolts.
- Damaged planing or moulding knives.
- Worn or damaged wires.
- Any other unsafe condition.

Weekly Maintenance:

- Check/adjust chain tension.
- Clean the four headstock columns.
- Clean cutterhead.

Monthly Check/Maintenance:

- Inspect for V-belt tension, damage, or wear.
- Clean/vacuum dust buildup from inside cabinet and off motor.
- Inspect all chains, sprockets, and gears and lubricate as necessary.

Cleaning

Cleaning the Model G0477 is relatively easy. Vacuum excess wood chips and sawdust, and wipe off the remaining dust with a dry cloth. If any resin has built up, use a resin dissolving cleaner to remove it. Treat all unpainted cast iron and steel with a non-staining lubricant after cleaning.

Unpainted Metal

Protect the unpainted metal surfaces on the table by wiping the table clean after every use—this ensures moisture from wood dust does not remain on bare metal surfaces.

Keep tables rust-free with regular applications of products like G96® Gun Treatment, SLIPIT®, or Boeshield® T-9.

Lubrication

All motor and cutterhead bearings are sealed and need no lubrication for the life of the machine. Lubricate all chains and gears with a general purpose grease when needed.

Anti-Kickback Fingers

The Model G0477 provides an anti-kickback system as a safety feature. The anti-kickback fingers hang from a rod suspended across the headstock. The anti-kickback fingers should be inspected regularly. Check the fingers to ensure that they swing freely and easily. If the fingers do not swing freely and easily, clean them with a wood resin solvent.

Do not apply oil or other lubricants to the anti-kickback fingers. Oil or grease will attract dust, restricting the free movement of the fingers.

! WARNING

Proper operation of the anti-kickback fingers are essential for the safe operation of this machine. Failure to ensure that they are working properly could result in serious operator injury.



SECTION 7: SERVICE

Review the troubleshooting and procedures in this section if a problem develops with your machine. If you need replacement parts or additional help with a procedure, call our Technical Support at (570) 546-9663. **Note:** Please gather the serial number and manufacture date of your machine before calling.

Troubleshooting Guide

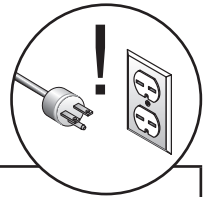

Motor & Machine Operation

| Symptom | Possible Cause | Possible Solution |
|--|---|--|
| Motor will not start. | <ol style="list-style-type: none"> 1. Machine circuit breaker has tripped. 2. Low voltage. 3. Open circuit in motor or loose connections. | <ol style="list-style-type: none"> 1. Press the circuit breaker reset button; investigate reason it tripped to prevent future problems. 2. Check power line for proper voltage. 3. Inspect all lead connections on motor for loose or open connections. |
| Fuses or circuit breakers blow. | <ol style="list-style-type: none"> 1. Short circuit in line cord or plug. | <ol style="list-style-type: none"> 1. Repair or replace cord or plug for damaged insulation and shorted wires. |
| Motor fails to develop full power (output of motor decreases rapidly with decrease in voltage at motor terminals). | <ol style="list-style-type: none"> 1. Power line overloaded with lights, appliances, and other motors. 2. Undersized wires or circuits too long. 3. Worn motor brushes. | <ol style="list-style-type: none"> 1. Reduce load on power line. 2. Increase wire sizes or reduce length of the circuit. 3. Replace motor brushes (Page 30) |
| Motor overheats. | <ol style="list-style-type: none"> 1. Motor overloaded during operation. 2. Air circulation through the motor restricted. | <ol style="list-style-type: none"> 1. Reduce cutting load; take lighter cuts. 2. Clean out motor, fan and dust collection ducting to provide normal air circulation. |
| Motor stalls or shuts off during a cut. | <ol style="list-style-type: none"> 1. Motor overloaded during operation. 2. Machine circuit breaker has tripped. 3. Short circuit in motor or loose connections. 4. External circuit breaker tripped. 5. Worn motor brushes. | <ol style="list-style-type: none"> 1. Reduce cutting load; take lighter cuts. 2. Press the circuit breaker reset button. 3. Repair or replace connections on motor for loose or shorted terminals or worn insulation. 4. Install correct circuit breaker; reduce # of machines running on that circuit. 5. Replace motor brushes (Page 30) |
| Cutterhead slows or squeals when cutting, especially on start-up. | <ol style="list-style-type: none"> 1. Belt(s) stretched or worn out. | <ol style="list-style-type: none"> 1. Replace belt(s) (Page 29) |
| Loud repetitious noise coming from machine. | <ol style="list-style-type: none"> 1. Pulley set screws or keys are missing or loose. 2. Dust collector fan is hitting the cover. 3. Belt(s) damaged. | <ol style="list-style-type: none"> 1. Inspect keys and set screws. Replace or tighten if necessary. 2. Adjust fan cover mounting position, tighten fan, or shim fan cover. 3. Replace belt(s) (Page 29) |
| Vibration when running or cutting. | <ol style="list-style-type: none"> 1. Loose or damaged moulding or planing knife. 2. Damaged belt(s). 3. Worn cutterhead bearings. | <ol style="list-style-type: none"> 1. Tighten or replace knife or blade. 2. Replace belt(s) (Page 29) 3. Check/replace cutterhead bearings. |



Planer/Moulder Operations

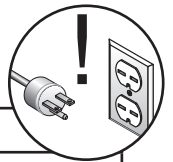

| Symptom | Possible Cause | Possible Solution |
|--|---|---|
| Excessive snipe (gouge in the end of the board that is uneven with the rest of the cut). Note: <i>A small amount of snipe is inevitable with all types of planers. The key is minimizing it as much as possible.</i> | <ol style="list-style-type: none"> 1. Outfeed extension slopes down or is not level with the main table. 2. Workpiece is not supported as it leaves the planer. | <ol style="list-style-type: none"> 1. Shim the outfeed extension wing level with the main table. 2. Hold the workpiece up slightly as it leaves the outfeed end of the planer. |
| Workpiece stops/slows in the middle of the cut. | <ol style="list-style-type: none"> 1. Taking too heavy of a cut. 2. Headstock height set too low. 3. Pitch and glue build up on planer components. | <ol style="list-style-type: none"> 1. Take a lighter cut. 2. Slightly raise the height of the headstock. 3. Clean internal cutterhead components with a pitch/resin dissolving solvent. |
| Chipping (consistent pattern). | <ol style="list-style-type: none"> 1. Knots or conflicting grain direction in wood. 2. Nicked or chipped knife. 3. Feeding workpiece too fast. 4. Taking too deep of a cut. | <ol style="list-style-type: none"> 1. Inspect workpiece for knots and grain direction; only use clean stock. 2. Replace the affected knife (Page 28), or have it sharpened. 3. Slow down the feed rate. 4. Take a smaller depth of cut. (Always reduce cutting depth when surface planing or working with hard woods.) |
| Chipping (inconsistent pattern). | <ol style="list-style-type: none"> 1. Chips aren't being properly expelled from the cutterhead. | <ol style="list-style-type: none"> 1. Check and clean fan housing and dust collection system for debris. |
| Fuzzy grain. | <ol style="list-style-type: none"> 1. Wood may have high moisture content or surface wetness. 2. Dull knives. | <ol style="list-style-type: none"> 1. Check moisture content and allow to dry if moisture is too high. 2. Replace the knives (Page 28) or have them professionally sharpened. |
| Long lines or ridges that run along the length of the board | <ol style="list-style-type: none"> 1. Nicked or chipped knife(s). | <ol style="list-style-type: none"> 1. Replace the knives (Page 28) or have them professionally sharpened. |
| Uneven knife marks, wavy surface, or chatter marks across the face of the board. | <ol style="list-style-type: none"> 1. Feeding workpiece too fast. 2. Knives not installed evenly. 3. Worn cutterhead bearings. | <ol style="list-style-type: none"> 1. Slow down the feed rate. 2. Adjust the knives so they sit on both knife location collars. 3. Replace cutterhead bearings. |
| Glossy surface. | <ol style="list-style-type: none"> 1. Knives are dull. 2. Feed rate too slow. 3. Cutting depth too shallow. | <ol style="list-style-type: none"> 1. Replace the knives (Page 28) or have them professionally sharpened. 2. Increase the feed rate. 3. Increase the depth of cut. |
| Uneven or crooked moulding pass. | <ol style="list-style-type: none"> 1. Fence guide not adjusted correctly. | <ol style="list-style-type: none"> 1. Ensure guide boards are parallel and adjusted correctly (Page 22) |



Changing Planing Knives

!WARNING

Planing knives are razor sharp! Always handle the planing knives with the magnets included with this machine. Failure to heed this warning can result in serious injury!

| | |
|----------------------|------------|
| Tools Needed: | Qty |
| Wrench 10mm..... | 1 |
| Hex Wrench 4mm..... | 1 |

The Model G0477 features double-edged planing knives that can be reversed when one edge becomes dull. Follow these instructions when reversing or replacing knives.

To change the planing knives:

1. UNPLUG THE PLANER/MOULDER FROM THE POWER SOURCE!
2. Remove the three cap screws that hold the cutterhead cover in place, as shown in **Figure 23**, and remove the cutterhead cover.



Figure 23. Cutterhead cover screws.

2. Push the cutterhead lock down, and rotate the cutterhead until a planing knife is visible, then release the cutterhead lock and slightly rotate the cutterhead in either direction until it locks.

5. Loosen the gib that holds the planing knife in place by turning the gib bolts clockwise. Start with the center bolt and alternate back and forth until the gib is completely looseened.
6. Using the magnets supplied with the planer/moulder, carefully lift the planing knife out of the cutterhead slot.
7. Pick up the new planing knife with the magnets and place it in the cutterhead slot.
8. Align the planing knife so that it rests evenly on both knife location collars, as shown in **Figure 24**.

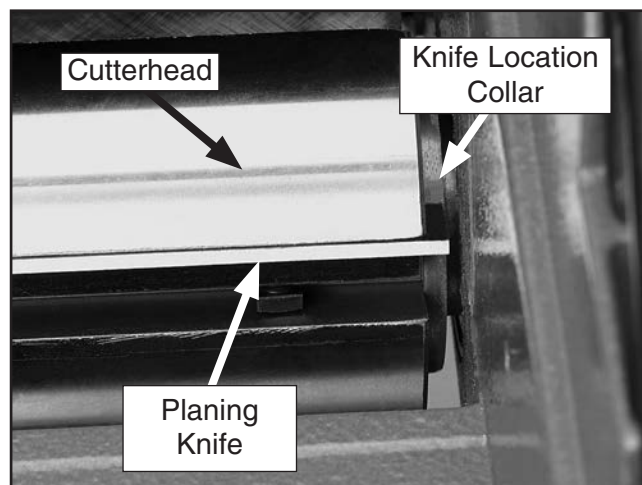

Figure 24. Knife location collar.

9. Tighten the gib bolts in the order indicated in **Figure 25**.

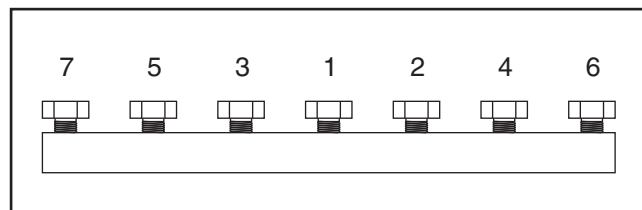

Figure 25. Gib bolt tightening sequence (planing knives).

10. Repeat **Steps 3–9** for the second planing knife.



Changing Belts

| Tools Needed: | Qty |
|---------------------|-----|
| Hex Wrench 4mm..... | 1 |
| Hex Wrench 5mm..... | 1 |

The Model G0477 features two ribbed belts, shown in **Figure 26**, that are generally good for the life of the machine. However, there are some instances where these belts must be replaced.

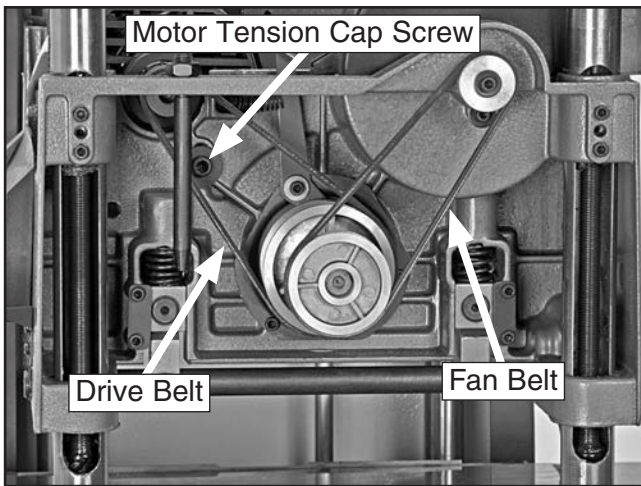

Figure 26. Drive and fan belts.

To change the drive and fan belts:

1. DISCONNECT THE MACHINE FROM THE POWER SOURCE!
2. Unscrew and remove the cap screw that holds the crank handle in place, and remove the crank handle.
3. Remove the four set screws that hold the housing caps in place.
4. Remove the right housing cap, feed rollers, preset depth gauge knob, and right housing cover.
5. Roll the fan belt off the pulleys.
6. Loosen the motor tension cap screw indicated in **Figure 26** to lower the motor and to put slack on the drive belt.
7. Roll the drive belt off the cutterhead pulley.

8. Lift the drive belt off the motor pulley and slide it through the space between the pulley and the headstock casting to free it from the machine.
9. Repeat **Steps 5, 7 and 8** in reverse order to install new fan and drive belts.
10. Once both belts have been installed, have an assistant lift the motor slightly to place tension on the drive belt, and tighten the cap screw loosened in **Step 6**. Both belts should now have a displacement or "give" of around 1/4" on each side.

Chain Tension and Headstock Leveling

| Tools Needed: | Qty |
|---------------------|-----|
| Hex Wrench 4mm..... | 1 |

If the headstock slips out of alignment with the table, the planer/moulder will produce an uneven cut. Often this is due to the chain losing tension over time. Follow these steps to correct headstock misalignment and to correct chain slack.

To correct a misaligned headstock:

1. DISCONNECT THE PLANER FROM THE POWER SOURCE!
2. Place even-sized shims under each corner of the headstock and lower it until the headstock rests on at least one of the shims.
3. If there is a gap between the headstock and any shim(s), proceed to the next step. If there is no gap, the headstock needs no adjustment.
4. Loosen, but do not remove, the two cap screws shown in **Figure 27** and slide the idler bracket so the chain loosens slightly.



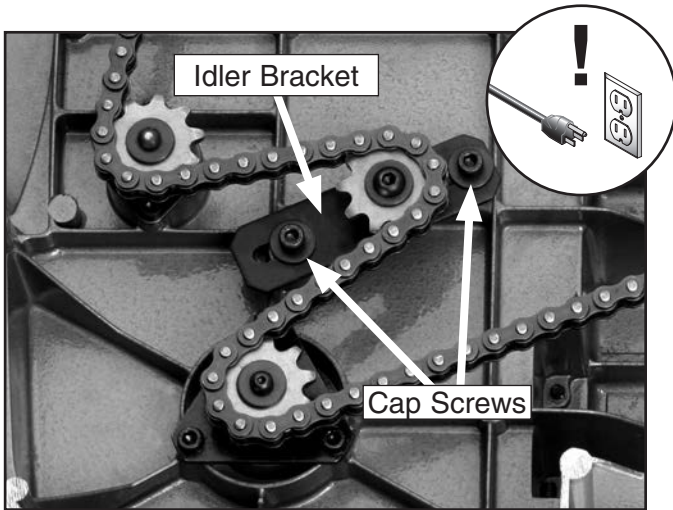

Figure 27. Underside of table.

NOTICE

DO NOT let the chain fall off the sprockets—returning it to its proper location without changing the table adjustments can be very difficult.

- For each corner of the headstock that needs to be re-aligned, rotate the relevant sprocket clockwise to raise the corner, or counter-clockwise to lower the corner, until the corner of the headstock contacts the shim.

Note: Movement of one sprocket tooth in relation to the chain raises or lowers that corner by approximately 0.006" (0.15mm).

- Place tension on the chain by sliding the idler bracket back to its original position, and tighten the two cap screws.
- Raise and lower the headstock to double check your adjustments. Any additional adjustments can be made by following **Steps 4–6** above.
- Check chain lubrication. Refer to **SECTION 6: MAINTENANCE** on **Page 25** for further details.

Changing Motor Brushes

Tools Needed: **Qty**
Flat Head Screwdriver..... 1

If the motor fails to develop full power or otherwise appears to run sluggishly, the motor brushes may need to be replaced.

To replace motor brushes:

- DISCONNECT THE PLANER FROM THE POWER SOURCE!**
- Remove the brush covers from the front and rear of the motor.
- Remove the brushes from the motor, as shown in Figure 28.

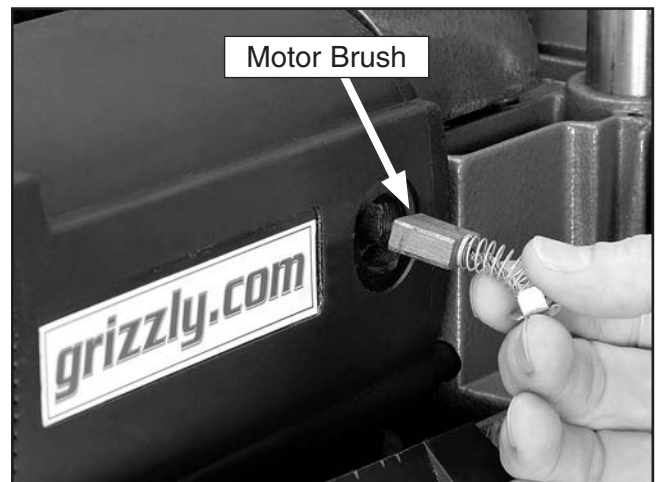

Figure 28. Motor brush replacement.

- Insert new carbon brushes into the slots in the motor housing, ensuring that the brass brush caps are slotted in completely.
- Fasten the brush covers in place.



Electrical Components

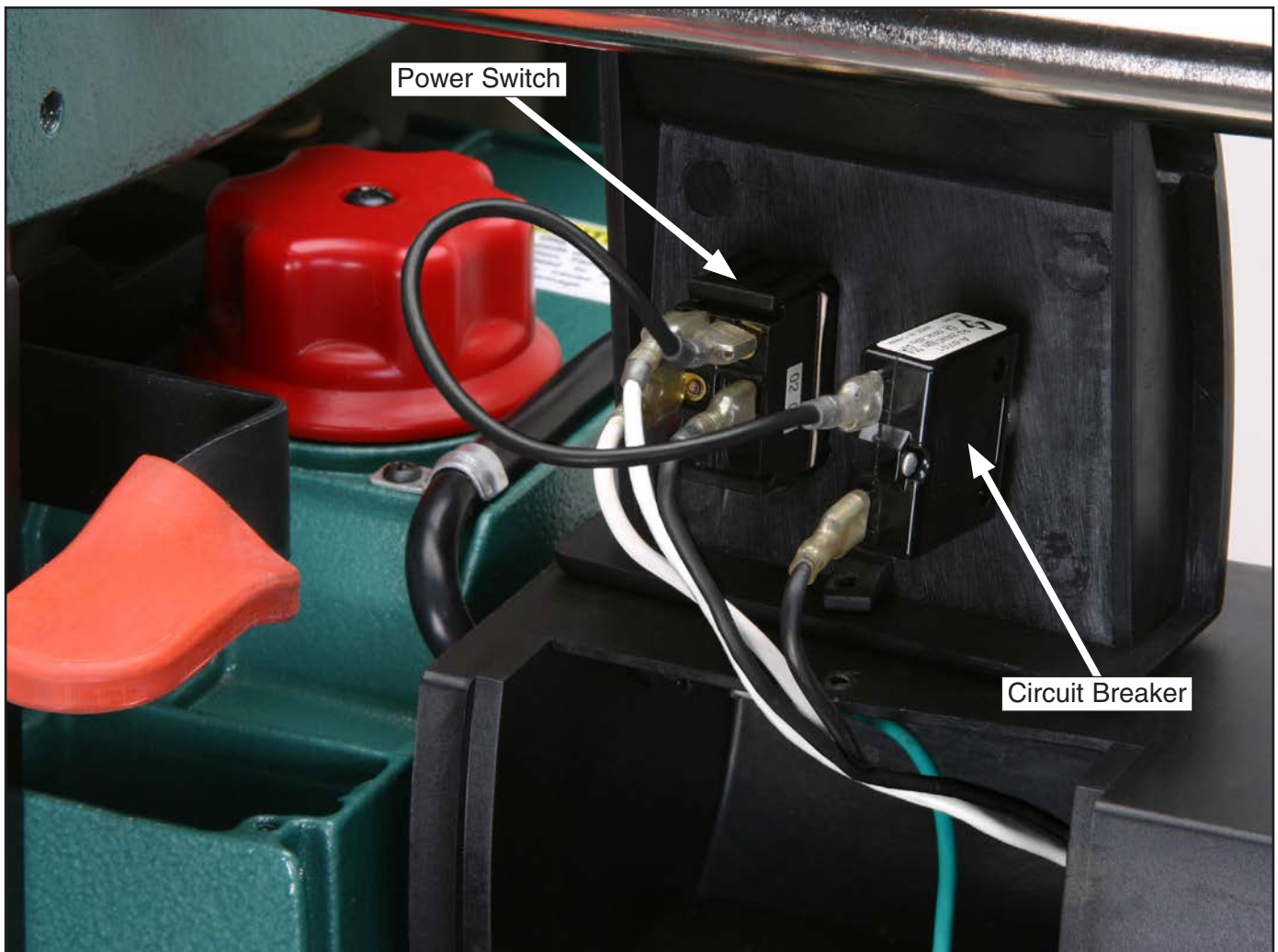

Figure 29. Rear of power switch and circuit breaker (switch assembly inverted).

Wiring Diagram



MODEL G0477
Wiring Diagram
Current as of 4/06

⚠ DANGER
 Disconnect power before performing any electrical service. Electricity presents serious shock hazards that will result in severe personal injury and even death!

COLOR KEY

| | |
|-------|--|
| BLACK | |
| WHITE | |
| GREEN | |

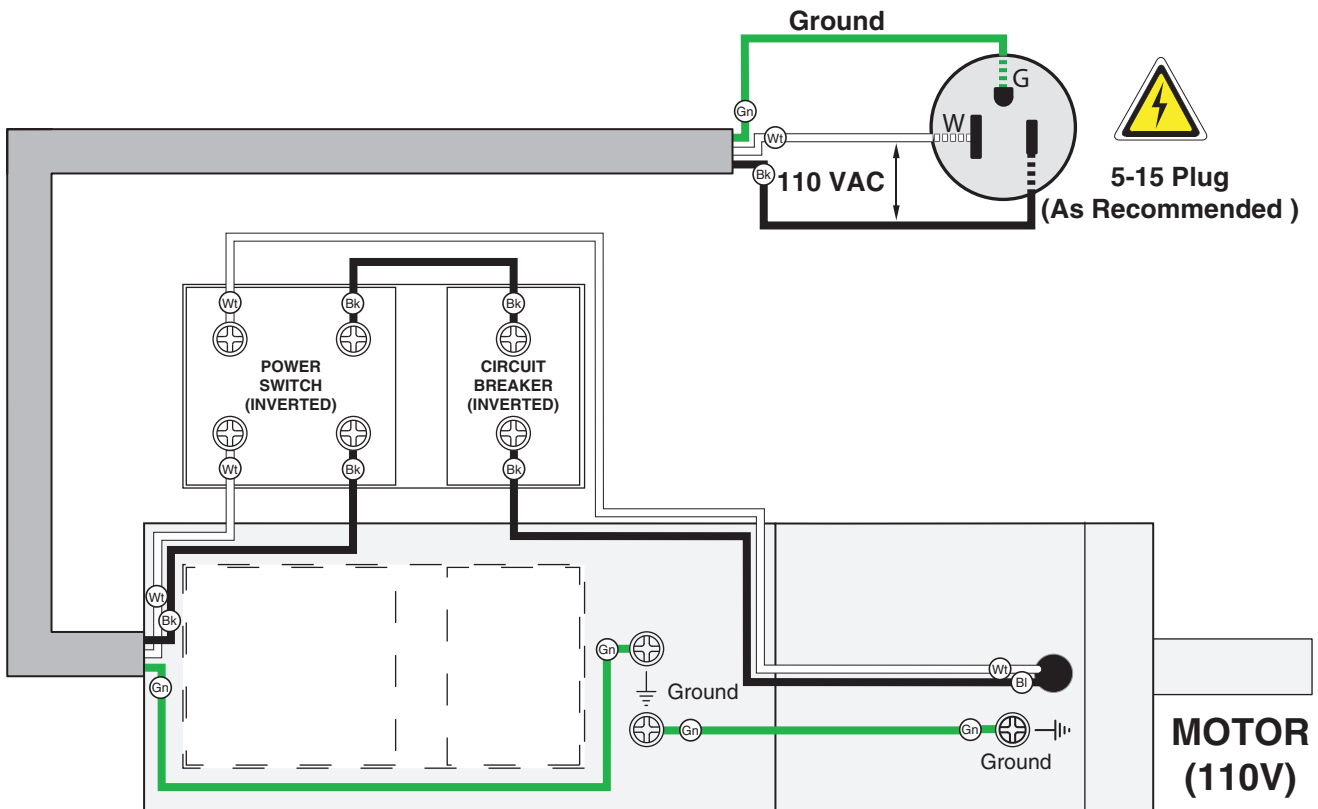

G0477 Body Breakdown

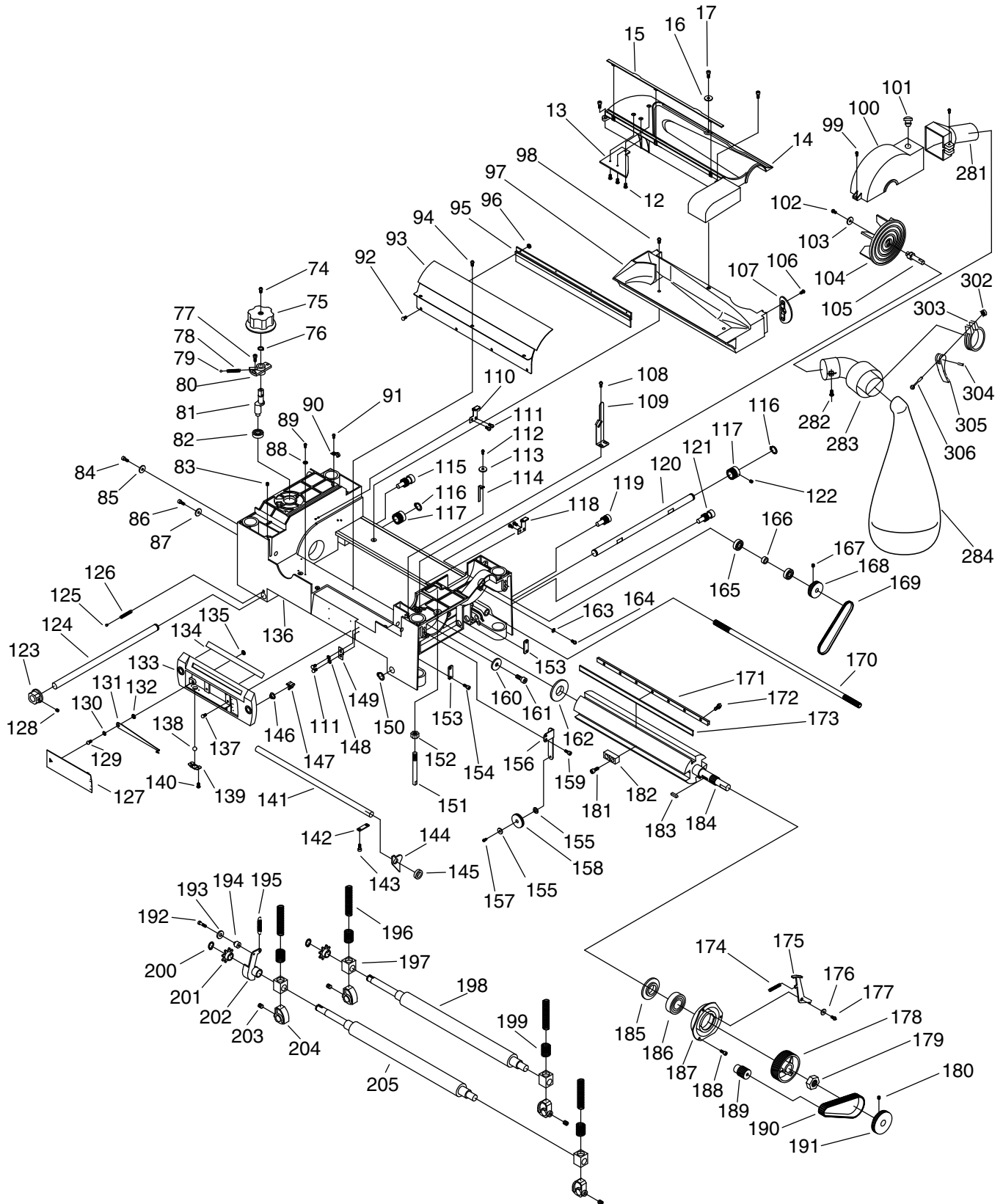

G0477 Table and Base Breakdown

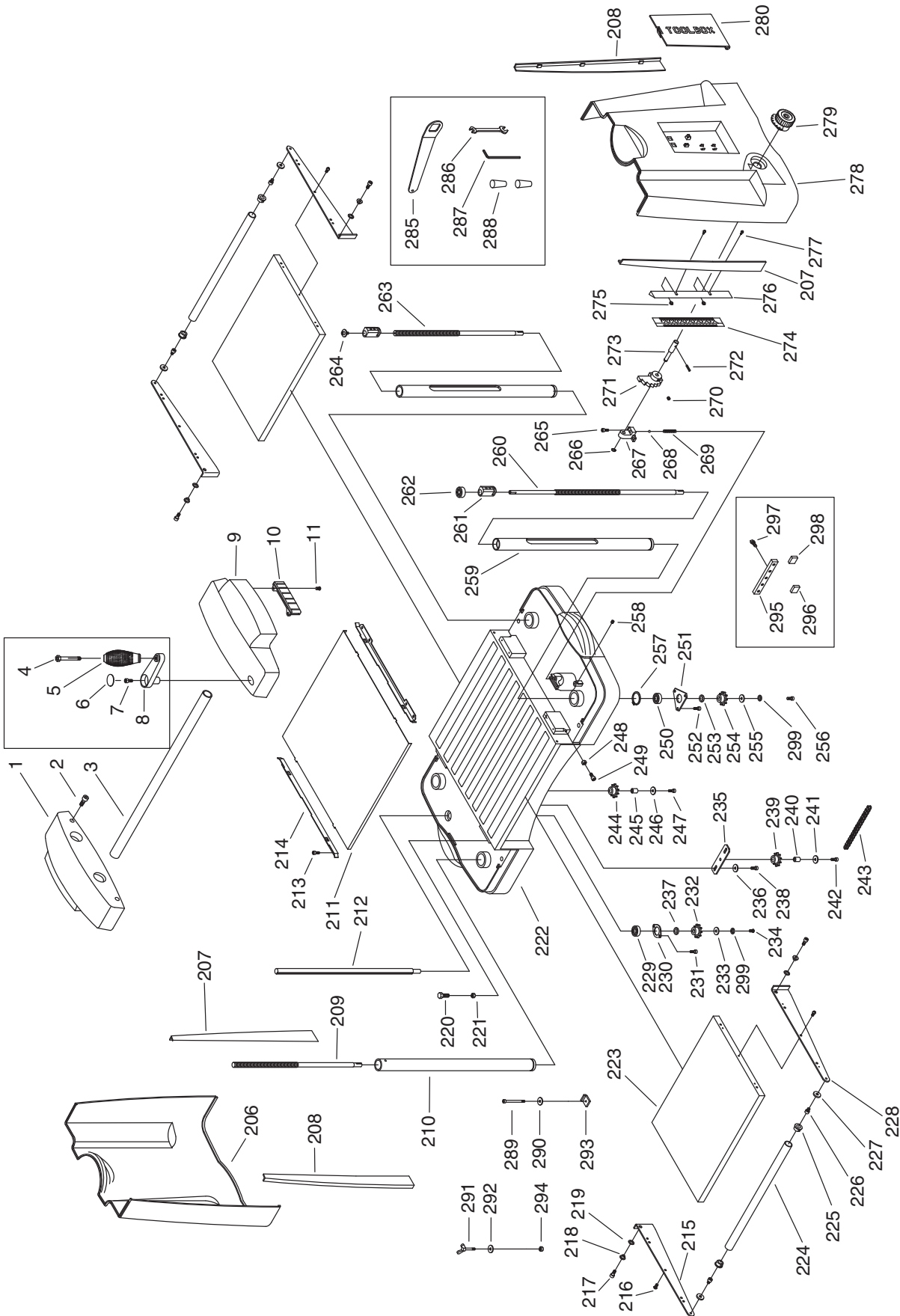

G0477 Gearbox Breakdown

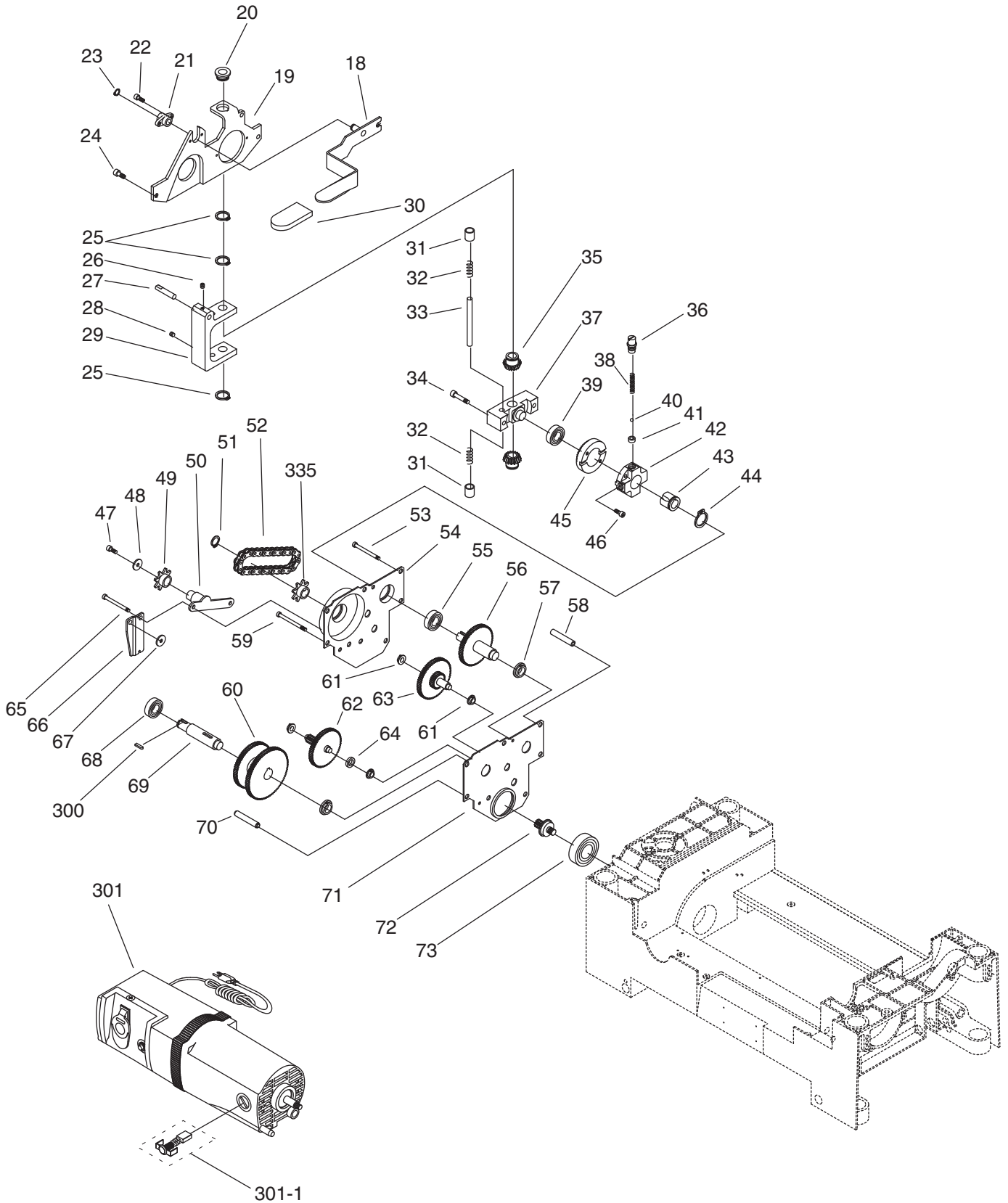

G0477 Stand Breakdown

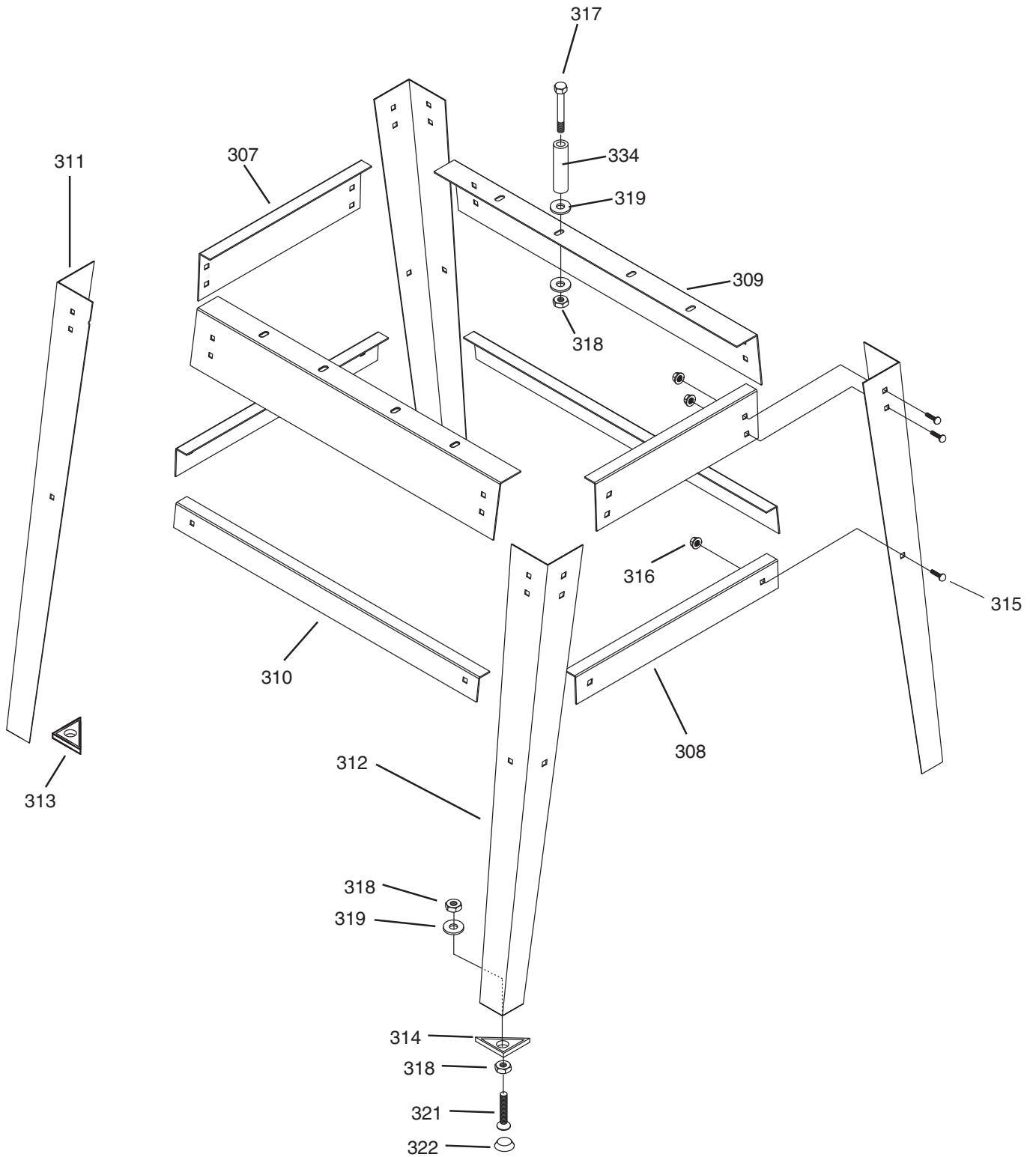

G0477 Labels

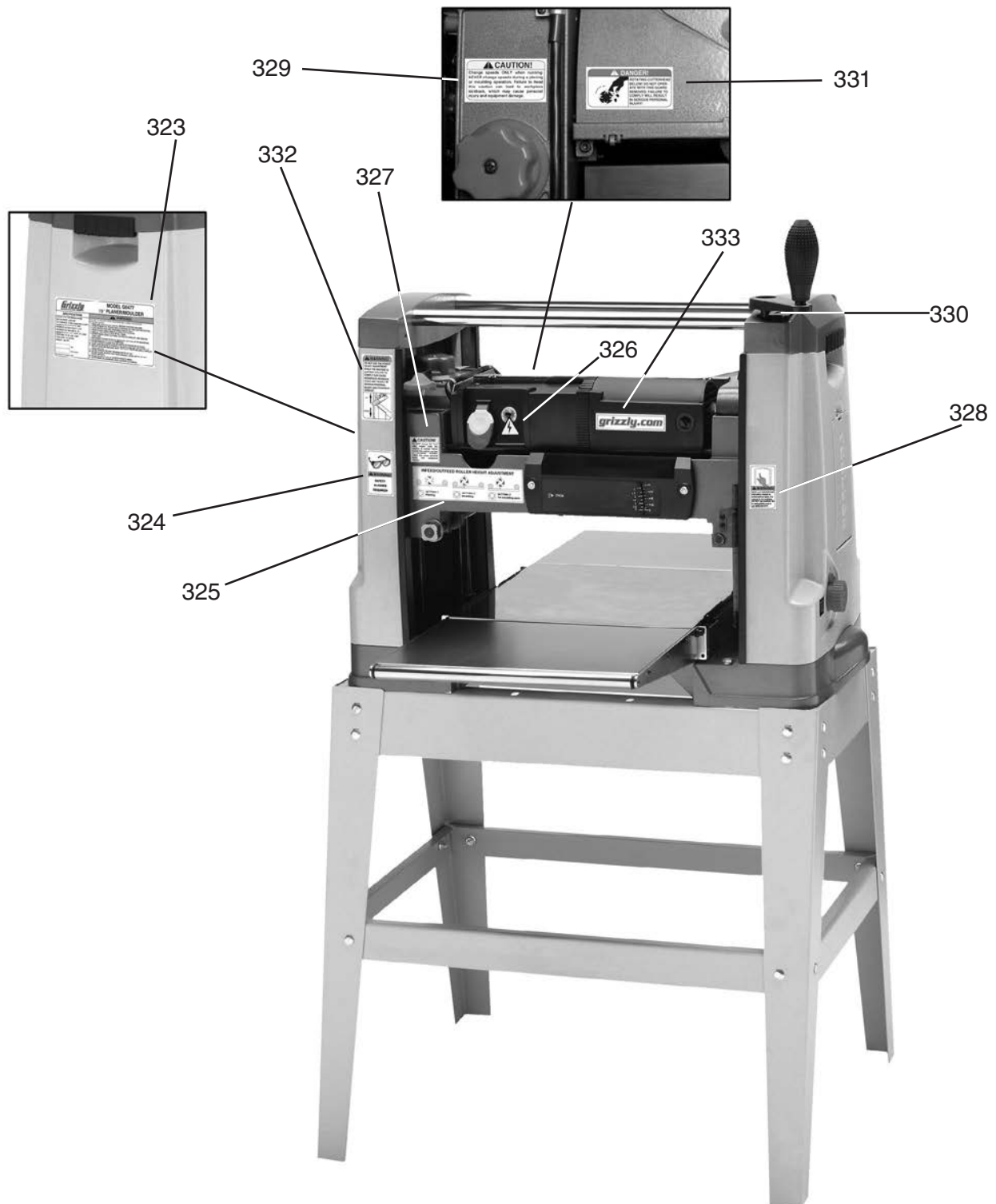

WARNING

Safety labels warn about machine hazards and ways to prevent injury. The owner of this machine **MUST** maintain the original location and readability of the labels on the machine. If any label is removed or becomes unreadable, **REPLACE** that label before using the machine again. Contact Grizzly at (800) 523-4777 or www.grizzly.com to order new labels.

Parts List

| REF | PART # | DESCRIPTION |
|------|----------|--------------------------------|
| 1 | P0477001 | CAP (LEFT) |
| 2 | PCAP04M | CAP SCREW M6-1 X 10 |
| 3 | P0477003 | ROLLER |
| 4 | P0477004 | SPECIAL CAP SCREW M8-1.25 X 72 |
| 5 | P0477005 | HANDLE CAP |
| 6 | P0477006 | PLUG |
| 7 | PCAP38M | CAP SCREW M5-.8 X 25 |
| 8 | P0477008 | ELEVATING HANDLE |
| 9 | P0477009 | CAP (RIGHT) |
| 10 | P0477010 | GRIP |
| 11 | PS09M | PHLP HD SCR M5-.8 X 10 |
| 12 | PS09M | PHLP HD SCR M5-.8 X 10 |
| 13 | P0477013 | CUTTERHEAD COVER BASE PLATE |
| 14 | P0477014 | CUTTERHEAD COVER |
| 15 | P0477015 | HINGED COVER |
| 16 | PW02M | FLAT WASHER 5MM |
| 17 | PCAP50M | CAP SCREW M5-.8 X 10 |
| 18 | P0477018 | HANDLE |
| 19 | P0477019 | BRACKET |
| 20 | P0477020 | BUSHING |
| 21 | P0477021 | BUSHING |
| 22 | PCAP50M | CAP SCREW M5-.8 X 10 |
| 23 | PR01M | EXT RETAINING RING 10MM |
| 24 | PCAP26M | CAP SCREW M6-1 X 12 |
| 25 | PR09M | EXT RETAINING RING 20MM |
| 26 | PSS26M | SET SCREW M5-.8 X 6 |
| 27 | P0477027 | SLIDING BAR |
| 28 | PSS26M | SET SCREW M5-.8 X 6 |
| 29 | P0477029 | GUIDE BRACKET |
| 30 | P0477030 | HANDLE GRIP |
| 31 | P0477031 | SLEEVE |
| 32 | P0477032 | COMPRESSION SPRING |
| 33 | P0477033 | GUIDE ROD |
| 34 | PCAP95M | CAP SCREW M5-.8 X 30 |
| 35 | P0477035 | GEAR |
| 36 | P0477036 | SPRING HOLDER |
| 37 | P0477037 | TRANSMISSION SEAT |
| 38 | P0477038 | COMPRESSION SPRING |
| 39 | P6002 | BALL BEARING 6002ZZ |
| 40 | P0477040 | STEEL BALL 6MM |
| 41 | P0477041 | BUSHING |
| 42 | P0477042 | TRANSMISSION COLLAR |
| 43 | P0477043 | HOLDER |
| 44 | PR58M | EXT RETAINING RING 24MM |
| 45 | P0477045 | GEAR |
| 46 | PCAP20M | CAP SCREW M5-.8 X 14 |
| 47 | PCAP04M | CAP SCREW M6-1 X 10 |
| 48 | PW03M | FLAT WASHER 6MM |
| 49 | P0477049 | SPROCKET |
| 49-1 | P0477049 | SPROCKET SMOOTH BORE |
| 50 | P0477050 | IDLER SEAT |

| REF | PART # | DESCRIPTION |
|------|------------|-------------------------|
| 51 | PR05M | EXT RETAINING RING 15MM |
| 52 | P0477052 | CHAIN |
| 53 | PCAP152M | CAP SCREW M5-.8 X 65 |
| 54 | P0477054 | OUTSIDE COVER |
| 55 | P6002 | BALL BEARING 6002ZZ |
| 56 | P0477056 | GEAR |
| 57 | P0477057 | BUSHING |
| 58 | P0477058 | SPACER |
| 59 | PCAP108M | CAP SCREW M5-.8 X 45 |
| 60 | P0477060 | GEAR |
| 61 | P0477061 | BUSHING |
| 62 | P0477062 | GEAR |
| 63 | P0477063 | GEAR |
| 63-1 | P0477063-1 | GEAR SHAFT |
| 64 | P0477064 | SPACER |
| 65 | PCAP152M | CAP SCREW M5-.8 X 65 |
| 66 | P0477066 | MOUNTING PLATE |
| 67 | P0477067 | SPINDLE WASHER |
| 68 | P6002ZZ | BALL BEARING 6002ZZ |
| 69 | P0477069 | SHAFT |
| 70 | P0477070 | SPACER |
| 71 | P0477071 | INSIDE COVER |
| 72 | P0477072 | PINION GEAR |
| 73 | P6205ZZ | BALL BEARING 6205ZZ |
| 74 | PS68M | PHLP HD SCR M6-1 X 10 |
| 75 | P0477075 | SPEED KNOB |
| 76 | PR03M | EXT RETAINING RING 12MM |
| 77 | PCAP50M | CAP SCREW M5-.8 X 10 |
| 78 | P0477078 | COMPRESSION SPRING |
| 79 | P0477079 | STEEL BALL |
| 80 | P0477080 | SET PLATE |
| 81 | P0477081 | ECCENTRIC SHAFT |
| 82 | P6002 | BALL BEARING 6002ZZ |
| 83 | PSS26M | SET SCREW M5-.8 X 6 |
| 84 | PCAP24M | CAP SCREW M5-.8 X 16 |
| 85 | PW02M | FLAT WASHER 5MM |
| 86 | PCAP24M | CAP SCREW M5-.8 X 16 |
| 87 | PW02M | FLAT WASHER 5MM |
| 88 | PTLW02M | EXT TOOTH WASHER 5MM |
| 89 | PS05M | PHLP HD SCR M5-.8 X 8 |
| 90 | P0477090 | CABLE CLAMP |
| 91 | PS09M | PHLP HD SCR M5-.8 X 10 |
| 92 | PS19M | PHLP HD SCR M5-.8 X 6 |
| 93 | P0477093 | CHIPBREAKER |
| 94 | PS09M | PHLP HD SCR M5-.8 X 10 |
| 95 | P0477095 | BRUSH |
| 96 | PN06M | HEX NUT M5-.8 |
| 97 | P0477097 | DUST CHUTE ASSEMBLY |
| 98 | PCAP26M | CAP SCREW M6-1 X 12 |
| 99 | PCAP50M | CAP SCREW M5-.8 X 10 |



| REF | PART # | DESCRIPTION |
|------|-----------|-----------------------------|
| 100 | P0477100 | FAN COVER |
| 101 | P0477101 | PLUG |
| 102 | PCAP26M | CAP SCREW M6-1 X 12 |
| 103 | PW03M | FLAT WASHER 6MM |
| 104 | P0477104 | FAN |
| 105 | P0477105 | FAN SHAFT |
| 106 | PHTEK37M | TAP SCREW M5 X 12 |
| 107 | P0477107 | CORD BLOCK |
| 108 | PHTEK34M | TAP SCREW M5 X 10 |
| 109 | P0477109 | SUPPORT PLATE |
| 110 | P0477110 | SUPPORT PLATE |
| 111 | PS17M | PHLP HD SCR M4-.7 X 6 |
| 112 | PHTEK34M | TAP SCREW M5 X 10 |
| 113 | PW02M | FLAT WASHER 5MM |
| 114 | P0477114 | BRACKET |
| 115 | P0477115 | GEAR |
| 116 | PR06M | EXT RETAINING RING 16MM |
| 117 | P0477117 | GEAR |
| 118 | P0477118 | SUPPORT PLATE |
| 119 | P0477119 | GEAR |
| 120 | P0477120 | ROLLER UP-DOWN SHAFT |
| 121 | P0477121 | GEAR |
| 122 | P0477122 | SPECIAL SET SCREW M6-1 X 10 |
| 123 | P0477123 | ROLLER ADJUSTER |
| 124 | P0477124 | ROLLER UP-DOWN SHAFT |
| 125 | P0477040 | STEEL BALL 6MM |
| 126 | P0477126 | COMPRESSION SPRING |
| 127 | P0477127 | POINTER COVER |
| 128 | PSS17M | SET SCREW M8-1.25 X 6 |
| 129 | PHTEK39M | TAP SCREW M4 X 12 |
| 130 | PW05M | FLAT WASHER 4MM |
| 131 | P0477131 | POINTER |
| 132 | P0477132 | BUSHING |
| 133 | P0477133 | POINTER HOUSING |
| 134 | P0477134 | BLACK TAPE 1-1/3" X 8" |
| 135 | PN04M | HEX NUT M4-.7 |
| 136 | P0477136 | UPPER FRAME |
| 136A | P0477136A | COMPLETE HEADSTOCK ASSY |
| 136B | P0477136B | COMPLETE GEAR BOX ASSY |
| 137 | PS07M | PHLP HD SCR M4-.7 X 8 |
| 138 | P0477138 | STEEL BALL 12MM |
| 139 | P0477139 | RETAINING PLATE |
| 140 | PHTEK33M | TAP SCREW M3 X 5 |
| 141 | P0477141 | SHAFT |
| 142 | P0477142 | SET PLATE |
| 143 | PCAP50M | CAP SCREW M5-.8 X 10 |
| 144 | P0477144 | ANTI-KICKBACK PAWL |
| 145 | P0477145 | BUSHING |
| 146 | P0477146 | MAGNET |
| 147 | P0477147 | SPACER |
| 148 | PW05M | FLAT WASHER 4MM |

| REF | PART # | DESCRIPTION |
|-----|----------|--------------------------|
| 149 | P0477149 | SET PLATE |
| 150 | PR06M | EXT RETAINING RING 16MM |
| 151 | P0477151 | STEP ROD |
| 152 | PN02M | HEX NUT M10-1.5 |
| 153 | P0477153 | SET PLATE |
| 154 | PCAP50M | CAP SCREW M5-.8 X 10 |
| 155 | P0477155 | BUSHING |
| 156 | P0477156 | IDLER BRACKET |
| 157 | PS08M | PHLP HD SCR M5-.8 X 12 |
| 158 | P0477158 | IDLER PULLEY |
| 159 | PCAP24M | CAP SCREW M5-.8 X 16 |
| 160 | PW01M | FLAT WASHER 8MM |
| 161 | PCAP31M | CAP SCREW M8-1.25 X 25 |
| 162 | P0477162 | KNIFE LOCATION COLLAR |
| 163 | PW02M | FLAT WASHER 5MM |
| 164 | PCAP50M | CAP SCREW M5-.8 X 10 |
| 165 | P6000 | BALL BEARING 6000ZZ |
| 166 | P0477166 | SPACER |
| 167 | PSS02M | SET SCREW M6-1 X 6 |
| 168 | P0477168 | FAN PULLEY |
| 169 | P0477169 | V-BELT 160J3 |
| 170 | P0477170 | GEAR SHAFT |
| 171 | P0477171 | LONG GIB |
| 172 | P0477172 | GIB BOLT 1/4"-28 X 1/4" |
| 173 | P0477173 | KNIVES |
| 174 | P0477174 | COMPRESSION SPRING |
| 175 | P0477175 | CUTTERHEAD LOCK |
| 176 | P0477176 | BUSHING |
| 177 | PCAP24M | CAP SCREW M5-.8 X 16 |
| 178 | P0477178 | CUTTERHEAD PULLEY |
| 179 | P0477179 | HEX NUT M20-2 |
| 180 | PSS02M | SET SCREW M6-1 X 6 |
| 181 | PCAP27M | CAP SCREW M6-1 X 14 |
| 182 | P0477182 | SPACER |
| 183 | PK34M | KEY 5 X 5 X 20 |
| 184 | P0477184 | CUTTERHEAD |
| 185 | P0477185 | KNIFE LOCATION COLLAR |
| 186 | P0477186 | BALL BEARING 6205ZZ |
| 187 | P0477187 | BEARING COVER |
| 188 | PCAP33M | CAP SCREW M5-.8 X 12 |
| 189 | P0477189 | MOTOR PULLEY |
| 190 | P0477190 | V-BELT 170J9 |
| 191 | P0477191 | CUTTERHEAD EXTEND PULLEY |
| 192 | PCAP15M | CAP SCREW M5-.8 X 20 |
| 193 | P0477193 | BUSHING |
| 194 | P0477194 | SET BLOCK |
| 195 | P0477195 | EXTENSION SPRING |
| 196 | P0477196 | COMPRESSION SPRING |
| 197 | P0477197 | BEARING BLOCK |
| 198 | P0477198 | ROLLER |
| 199 | P0477199 | COMPRESSION SPRING |



| REF | PART # | DESCRIPTION |
|-----|----------|-------------------------|
| 200 | PR05M | EXT RETAINING RING 15MM |
| 201 | P0477201 | SPROCKET |
| 202 | P0477202 | CHAIN PROTECTOR |
| 203 | PSS16M | SET SCREW M8-1.25 X 10 |
| 204 | P0477204 | ROLLER BLOCK |
| 205 | P0477205 | ROLLER |
| 206 | P0477206 | SIDE COVER (LEFT) |
| 207 | P0477207 | SIDE COVER FRAME |
| 208 | P0477208 | SIDE COVER FRAME |
| 209 | P0477209 | ELEVATING SCREW |
| 210 | P0477210 | COLUMN |
| 211 | P0477211 | PLATEN |
| 212 | P0477212 | GUIDE ROD |
| 213 | PCAP50M | CAP SCREW M5-.8 X 10 |
| 214 | P0477214 | GUIDE |
| 215 | P0477215 | ROLLER PLATE (LEFT) |
| 216 | PS07M | PHLP HD SCR M4-.7 X 8 |
| 217 | PCAP27M | CAP SCREW M6-1 X 14 |
| 218 | P0477218 | BUSHING |
| 219 | P0477219 | WAVE WASHER 10MM |
| 220 | PB09M | HEX BOLT M8-1.25 X 20 |
| 221 | PN03M | HEX NUT M8-1.25 |
| 222 | P0477222 | BASE |
| 223 | P0477223 | EXTENSION TABLE |
| 224 | P0477224 | SUPPORT ROLLER |
| 225 | P0477225 | BUSHING |
| 226 | PCAP68M | CAP SCREW M6-1 X 8 |
| 227 | P0477227 | SPACER |
| 228 | P0477228 | ROLLER PLATE (LEFT) |
| 229 | P6000 | BALL BEARING 6000ZZ |
| 230 | P0477230 | BEARING RETAINER |
| 231 | PFB14M | FLANGE BOLT M5-.8 X 12 |
| 232 | P0477232 | SPROCKET |
| 233 | PW05M | FLAT WASHER 4MM |
| 234 | PCAP23M | CAP SCREW M4-.7 X 12 |
| 235 | P0477235 | IDLER BRACKET |
| 236 | PW02M | FLAT WASHER 5MM |
| 237 | PW04M | FLAT WASHER 10MM |
| 238 | PCAP33M | CAP SCREW M5-.8 X 12 |
| 239 | P0477239 | SPROCKET |
| 240 | P0477240 | BUSHING |
| 241 | PW03M | FLAT WASHER 6MM |
| 242 | PCAP02M | CAP SCREW M6-1 X 20 |
| 243 | P0477243 | CHAIN |
| 244 | P0477244 | SPROCKET |
| 245 | P0477245 | BUSHING |
| 246 | PW03M | FLAT WASHER 6MM |
| 247 | PCAP06M | CAP SCREW M6-1 X 25 |
| 248 | PN01M | HEX NUT M6-1 |
| 249 | PB10M | HEX BOLT M6-1 X 25 |
| 250 | P6000 | BALL BEARING 6000ZZ |
| 251 | P0477251 | BEARING RETAINER |

| REF | PART # | DESCRIPTION |
|-----|----------|--------------------------|
| 252 | PFB14M | FLANGE BOLT M5-.8 X 12 |
| 253 | P0477253 | SPINDLE WASHER |
| 254 | P0477254 | SPROCKET |
| 255 | PW05M | FLAT WASHER 4MM |
| 256 | PCAP23M | CAP SCREW M4-.7 X 12 |
| 257 | PR15M | EXT RETAINING RING 30MM |
| 258 | PSS26M | SET SCREW M5-.8 X 6 |
| 259 | P0477259 | COLUMN |
| 260 | P0477260 | ELEVATING SCREW |
| 261 | P0477261 | ELEVATING NUT |
| 262 | P0477262 | BUSHING |
| 263 | P0477263 | ELEVATING SCREW |
| 264 | PFB14M | FLANGE BOLT M5-.8 X 12 |
| 265 | PCAP24M | CAP SCREW M5-.8 X 16 |
| 266 | PR39M | EXT RETAINING RING 8MM |
| 267 | P0477267 | STEP BRACKET |
| 268 | P0477040 | STEEL BALL 6MM |
| 269 | P0477269 | COMPRESSION SPRING |
| 270 | PSS02M | SET SCREW M6-1 X 6 |
| 271 | P0477271 | PRESET THICKNESS STOP |
| 272 | PRP01M | ROLL PIN 4 X 18 |
| 273 | P0477273 | SHAFT |
| 274 | P0477274 | SCALE |
| 275 | PN07M | HEX NUT M3-.5 |
| 276 | P0477276 | SCALE SUPPORT |
| 277 | PS79M | PHLP HD SCR M3-.5 X 8 |
| 278 | P0477278 | SIDE COVER (RIGHT) |
| 279 | P0477279 | STEP KNOB |
| 280 | P0477280 | TOOL BOX COVER |
| 281 | P0477281 | DUST CHUTE |
| 281 | P0477281 | DUST CHUTE |
| 282 | PCAP06M | CAP SCREW M6-1 X 25 |
| 282 | PCAP06M | CAP SCREW M6-1 X 25 |
| 283 | P0477283 | DUST CHUTE ADAPTER |
| 283 | P0477283 | DUST CHUTE ADAPTER |
| 284 | P0477284 | DUST BAG |
| 284 | P0477284 | DUST BAG |
| 285 | P0477285 | SQUARE BOX WRENCH 26MM |
| 286 | PWR810 | OPEN END WRENCH 8/10MM |
| 287 | PAW04M | HEX WRENCH 4MM |
| 288 | P0477288 | MAGNET |
| 289 | PSB153M | CAP SCREW M5-.8 X 60 |
| 290 | PW02M | FLAT WASHER 5MM |
| 291 | P0477291 | WING BOLT 1/4-20 X 1-1/4 |
| 292 | PW06 | FLAT WASHER 1/4 |
| 293 | P0477293 | AUX GUIDE CLAMP |
| 294 | PN05 | HEX NUT 1/4-20 |
| 295 | P0477295 | SHORT GIB |
| 296 | P0477296 | SPACER |
| 297 | PB02M | HEX BOLT M6-1 X 12 |
| 298 | P0477298 | SPACER |
| 299 | PLW02M | LOCK WASHER 4MM |



| REF | PART # | DESCRIPTION |
|-------|------------|----------------------------|
| 300 | PK48M | KEY 4 X 4 X 20 |
| 301 | P0477301 | MOTOR 2-1/2HP, 110V |
| 301-1 | P0477301-1 | CARBON BRUSH ASSY |
| 302 | PN01M | HEX NUT M6-1 |
| 303 | P0477303 | BAG CLAMP |
| 304 | PRP03M | ROLL PIN 5 X 20 |
| 305 | P0477305 | CLAMP HANDLE |
| 306 | P0477306 | RING BOLT M6-1 X 50 |
| 307 | P0477307 | SHORT FRAME PIECE |
| 308 | P0477308 | SHORT BRACE |
| 309 | P0477309 | LONG FRAME PIECE |
| 310 | P0477310 | LONG BRACE |
| 311 | P0477311 | NOTCHED LEG |
| 312 | P0477312 | PLAIN LEG |
| 313 | P0477313 | RUBBER FOOT |
| 314 | P0477314 | RUBBER FOOT |
| 315 | PCB06M | CARRIAGE BOLT M8-1.25 X 16 |
| 316 | PFN01M | FLANGE NUT M8-1.25 |

| REF | PART # | DESCRIPTION |
|-----|-----------|-------------------------------|
| 317 | PB82M | HEX BOLT M8-1.25 X 80 |
| 318 | PN03M | HEX NUT M8-1.25 |
| 319 | PW01M | FLAT WASHER 8MM |
| 321 | PFH42M | FLAT HD SCR M8-1.25 X 40 |
| 322 | P0477322 | RUBBER CAP |
| 323 | P0477323 | MACHINE ID LABEL |
| 324 | PLABEL-11 | SAFETY GLASSES 2" X 3-5/16" |
| 325 | P0477325 | ROLLER PRESET LABEL |
| 326 | PLABEL-14 | ELECTRICITY LABEL |
| 327 | P0477327 | FEED ROLLER CAUTION LABEL |
| 328 | PLABEL-12 | READ MANUAL 2" X 3-5/16" |
| 329 | P0477329 | SPEED CHANGE CAUTION LABEL |
| 330 | P0477330 | CRANK HANDLE LABEL |
| 331 | P0477331 | CUTTERHEAD WARNING LABEL |
| 332 | P0477332 | POWER ADJUST LABEL |
| 333 | P0477333 | GRIZZLY.COM LABEL 1" X 4-1/4" |
| 334 | P0477334 | SPACER 8.5 X 14 X 57 |
| 335 | P1017134 | KEY SPROCKET |





WARRANTY CARD

Name _____
 Street _____
 City _____ State _____ Zip _____
 Phone # _____ Email _____
 Model # _____ Order # _____ Serial # _____

The following information is given on a voluntary basis. It will be used for marketing purposes to help us develop better products and services. **Of course, all information is strictly confidential.**

1. How did you learn about us?

Advertisement Friend Catalog
 Card Deck Website Other:

2. Which of the following magazines do you subscribe to?

| | | |
|---|--|---|
| <input type="checkbox"/> Cabinetmaker & FDM | <input type="checkbox"/> Popular Science | <input type="checkbox"/> Wooden Boat |
| <input type="checkbox"/> Family Handyman | <input type="checkbox"/> Popular Woodworking | <input type="checkbox"/> Woodshop News |
| <input type="checkbox"/> Hand Loader | <input type="checkbox"/> Precision Shooter | <input type="checkbox"/> Woodsmith |
| <input type="checkbox"/> Handy | <input type="checkbox"/> Projects in Metal | <input type="checkbox"/> Woodwork |
| <input type="checkbox"/> Home Shop Machinist | <input type="checkbox"/> RC Modeler | <input type="checkbox"/> Woodworker West |
| <input type="checkbox"/> Journal of Light Cont. | <input type="checkbox"/> Rifle | <input type="checkbox"/> Woodworker's Journal |
| <input type="checkbox"/> Live Steam | <input type="checkbox"/> Shop Notes | <input type="checkbox"/> Other: |
| <input type="checkbox"/> Model Airplane News | <input type="checkbox"/> Shotgun News | |
| <input type="checkbox"/> Old House Journal | <input type="checkbox"/> Today's Homeowner | |
| <input type="checkbox"/> Popular Mechanics | <input type="checkbox"/> Wood | |

3. What is your annual household income?

\$20,000-\$29,000 \$30,000-\$39,000 \$40,000-\$49,000
 \$50,000-\$59,000 \$60,000-\$69,000 \$70,000+

4. What is your age group?

20-29 30-39 40-49
 50-59 60-69 70+

5. How long have you been a woodworker/metalworker?

0-2 Years 2-8 Years 8-20 Years 20+ Years

6. How many of your machines or tools are Grizzly?

0-2 3-5 6-9 10+

7. Do you think your machine represents a good value? Yes No

8. Would you recommend Grizzly Industrial to a friend? Yes No

9. Would you allow us to use your name as a reference for Grizzly customers in your area?

Note: We never use names more than 3 times. Yes No

10. Comments: _____

CUT ALONG DOTTED LINE

FOLD ALONG DOTTED LINE



Place
Stamp
Here



GRIZZLY INDUSTRIAL, INC.
P.O. BOX 2069
BELLINGHAM, WA 98227-2069



FOLD ALONG DOTTED LINE

Send a Grizzly Catalog to a friend:

| |
|----------------------------------|
| Name _____ |
| Street _____ |
| City _____ State _____ Zip _____ |

TAPE ALONG EDGES--PLEASE DO NOT STAPLE

WARRANTY AND RETURNS

Grizzly Industrial, Inc. warrants every product it sells for a period of **1 year** to the original purchaser from the date of purchase. This warranty does not apply to defects due directly or indirectly to misuse, abuse, negligence, accidents, repairs or alterations or lack of maintenance. This is Grizzly's sole written warranty and any and all warranties that may be implied by law, including any merchantability or fitness, for any particular purpose, are hereby limited to the duration of this written warranty. We do not warrant or represent that the merchandise complies with the provisions of any law or acts unless the manufacturer so warrants. In no event shall Grizzly's liability under this warranty exceed the purchase price paid for the product and any legal actions brought against Grizzly shall be tried in the State of Washington, County of Whatcom.

We shall in no event be liable for death, injuries to persons or property or for incidental, contingent, special, or consequential damages arising from the use of our products.

To take advantage of this warranty, contact us by mail or phone and give us all the details. We will then issue you a "Return Number," which must be clearly posted on the outside as well as the inside of the carton. We will not accept any item back without this number. Proof of purchase must accompany the merchandise.

The manufacturers reserve the right to change specifications at any time because they constantly strive to achieve better quality equipment. We make every effort to ensure that our products meet high quality and durability standards and we hope you never need to use this warranty.

Please feel free to write or call us if you have any questions about the machine or the manual.

Thank you again for your business and continued support. We hope to serve you again soon.

grizzly.com[®]

TOOL WEBSITE

Buy Direct and Save with Grizzly[®] – Trusted, Proven and a Great Value!
~Since 1983~

***Visit Our Website Today For
Current Specials!***

**ORDER
24 HOURS A DAY!
1-800-523-4777**



Free Manuals Download Website

<http://myh66.com>

<http://usermanuals.us>

<http://www.somanuals.com>

<http://www.4manuals.cc>

<http://www.manual-lib.com>

<http://www.404manual.com>

<http://www.luxmanual.com>

<http://aubethermostatmanual.com>

Golf course search by state

<http://golfingnear.com>

Email search by domain

<http://emailbydomain.com>

Auto manuals search

<http://auto.somanuals.com>

TV manuals search

<http://tv.somanuals.com>