

# *Grizzly* *Industrial, Inc.*®

## **MODEL G0533 3HP DRY SPRAY BOOTH OWNER'S MANUAL**



COPYRIGHT © DECEMBER, 2005 BY GRIZZLY INDUSTRIAL, INC., REVISED APRIL, 2011 (TRTS)  
**WARNING: NO PORTION OF THIS MANUAL MAY BE REPRODUCED IN ANY SHAPE  
OR FORM WITHOUT THE WRITTEN APPROVAL OF GRIZZLY INDUSTRIAL, INC.**  
(FOR MACHINES MFG. SINCE 3/11) #BL5685 PRINTED IN TAIWAN



# **WARNING!**

**This manual provides critical safety instructions on the proper setup, operation, maintenance, and service of this machine/tool. Save this document, refer to it often, and use it to instruct other operators.**

**Failure to read, understand and follow the instructions in this manual may result in fire or serious personal injury—including amputation, electrocution, or death.**

**The owner of this machine/tool is solely responsible for its safe use. This responsibility includes but is not limited to proper installation in a safe environment, personnel training and usage authorization, proper inspection and maintenance, manual availability and comprehension, application of safety devices, cutting/sanding/grinding tool integrity, and the usage of personal protective equipment.**

**The manufacturer will not be held liable for injury or property damage from negligence, improper training, machine modifications or misuse.**



# **WARNING!**

**Some dust created by power sanding, sawing, grinding, drilling, and other construction activities contains chemicals known to the State of California to cause cancer, birth defects or other reproductive harm. Some examples of these chemicals are:**

- **Lead from lead-based paints.**
- **Crystalline silica from bricks, cement and other masonry products.**
- **Arsenic and chromium from chemically-treated lumber.**

**Your risk from these exposures varies, depending on how often you do this type of work. To reduce your exposure to these chemicals: Work in a well ventilated area, and work with approved safety equipment, such as those dust masks that are specially designed to filter out microscopic particles.**

# Table of Contents

<b>INTRODUCTION.....</b>	<b>2</b>	<b>SECTION 4: OPERATIONS .....</b>	<b>18</b>
Manual Accuracy .....	2	Filter Indicator .....	18
Contact Info.....	2	<b>SECTION 5: MAINTENANCE.....</b>	<b>20</b>
Data Sheet.....	3	Schedule .....	20
Identification.....	5	Exhaust Fan and Motor .....	20
<b>SECTION 1: SAFETY.....</b>	<b>6</b>	Ducting.....	20
Safety Instructions for Machinery .....	6	Air Filter Indicator.....	20
Additional Safety Instructions .....	8	Interior Booth Walls .....	20
for Dry Spray Booths .....	8	Exhaust Filters .....	20
<b>SECTION 2: POWER SUPPLY .....</b>	<b>9</b>	<b>SECTION 6: SERVICE .....</b>	<b>21</b>
Availability.....	9	Troubleshooting .....	21
Full-Load Current Rating .....	9	Motor and Electrical.....	21
Circuit Requirements for 230V .....	9	Spray Booth Operations .....	21
Connection Type .....	9	G0533 Wiring Diagram .....	22
<b>SECTION 3: SET UP .....</b>	<b>10</b>	Main Parts Breakdown.....	23
Needed for Set Up.....	10	Main Parts List.....	24
Unpacking .....	10	Safety Label Placement and Parts List.....	25
Inventory .....	11		
Hardware Recognition Chart .....	12		
Site Considerations.....	13		
Floor Load .....	13		
Working Clearances .....	13		
Exhaust Fan.....	13		
Outlet .....	14		
Support Bar.....	14		
Curtains.....	14		
Work Table.....	15		
Filters .....	16		
Ducting.....	16		
Air Filter Indicator.....	17		

# INTRODUCTION

## Manual Accuracy

We are proud to offer this manual with your new machine! We've made every effort to be exact with the instructions, specifications, drawings, and photographs of the machine we used when writing this manual. However, sometimes we still make an occasional mistake.

Also, owing to our policy of continuous improvement, **your machine may not exactly match the manual**. If you find this to be the case, and the difference between the manual and machine leaves you in doubt, check our website for the latest manual update or call technical support for help.

Before calling, find the manufacture date of your machine by looking at the date stamped into the machine ID label (see below). This will help us determine if the manual version you received matches the manufacture date of your machine.

**Grizzly Industrial** MODEL GXXXX  
MACHINE NAME

SPECIFICATIONS	WARNING!
Motor: Specification: Specification: Specification: Weight: <input type="text"/> Date <input type="text"/> Serial Number <small>Manufactured for Grizzly in Taiwan</small>	ing this machine: operation. s and respirator. sted/setup and suit before starting. 4. make sure the motor has stopped and disconnect power before adjustments, maintenance, or service. 5. DO NOT expose to rain or dampness. 6. DO NOT modify this machine in any way. 7. DO NOT remove safety guards. 8. Never leave machine running unattended. 9. DO NOT operate under the influence of drugs or alcohol. 10. Maintain machine carefully to prevent accidents.

For your convenience, we post all available manuals and manual updates for free on our website at [www.grizzly.com](http://www.grizzly.com). Any updates to your model of machine will be reflected in these documents as soon as they are complete.

## Contact Info

We stand behind our machines. If you have any questions or need help, use the information below to contact us. Before contacting, please get the serial number and manufacture date of your machine. This will help us help you faster.

Grizzly Technical Support  
1203 Lycoming Mall Circle  
Muncy, PA 17756  
Phone: (570) 546-9663  
Email: [techsupport@grizzly.com](mailto:techsupport@grizzly.com)

We want your feedback on this manual. What did you like about it? Where could it be improved? Please take a few minutes to give us feedback.

Grizzly Documentation Manager  
P.O. Box 2069  
Bellingham, WA 98227-2069  
Email: [manuals@grizzly.com](mailto:manuals@grizzly.com)





# MACHINE DATA SHEET

Customer Service #: (570) 546-9663 · To Order Call: (800) 523-4777 · Fax #: (800) 438-5901

## MODEL G0533 3 HP DRY SPRAY BOOTH

### Product Dimensions:

Weight..... 607 lbs.  
 Width (side-to-side) x Depth (front-to-back) x Height..... 63 x 52 x 100 in.  
 Footprint (Length x Width)..... 51 x 24 in.

### Shipping Dimensions:

Type..... Cardboard/Wood Runne  
 Content..... Machine  
 Weight..... 754 lbs  
 Length x Width x Height..... 52 x 27 x 77 in.

### Electrical:

Power Requirement..... 230V, Single-Phase, 60 Hz  
 Full-Load Current Rating..... 15A  
 Minimum Circuit Size..... 20A  
 Switch..... Magnetic  
 Switch Voltage..... 220V  
 Cord Length..... 4 ft.  
 Plug Included..... No  
 Recommended Plug/Outlet Type..... Hardwire

### Motors:

#### Main

Type..... Explosion Proof  
 Horsepower..... 3 HP  
 Voltage..... 230V  
 Phase..... Single  
 Amps..... 15A  
 Speed..... 1725 RPM  
 Cycle..... 60 Hz  
 Number of Speeds..... 1  
 Power Transfer ..... Direct Drive  
 Bearings..... Special Explosion Proof

### Main Specifications:

#### Operation Info

Air Suction Cap..... 1900 CFM  
 First Stage Filter Micron..... 30  
 Second Stage Filter Micron..... 10  
 Third Stage Filter Micron..... 5  
 Impeller Type..... Squirrel Cage  
 Impeller Size..... 12 in.  
 Inlet Hole Diameter..... 13 in.  
 Outlet Size..... 12 in.



**Filter Info**

No. Of First Stage Filters.....	6
First Stage Filter Length.....	19-1/2 in.
First Stage Filter Width.....	15-1/2 in.
First Stage Filter Thickness.....	1-3/4 in.
No. Of Second Stage Filters.....	6
Second Stage Filter Length.....	19-1/2 in.
Second Stage Filter Width.....	15-1/2 in.
Second Stage Filter Thickness.....	1-3/4 in.
No. Of Third Stage Filters.....	6
Third Stage Filter Length.....	15-1/2 in.
Third Stage Filter Width.....	15-1/2 in.
Third Stage Filter Thickness.....	1-3/4 in.

**Table Info**

Table Size Length.....	22 in.
Table Size Width.....	51 in.
Floor To Table Height.....	51 in.

**Construction Info**

Frame.....	16 gauge Steel
Base.....	Steel
Impeller.....	Aluminum
Table.....	14 gauge Steel
Side Wall.....	18 gauge Steel Frame
Filter.....	Pleated, Woven Fabric
Paint.....	Powder Coated

**Other Specifications:**

ISO 9001 Factory .....	Yes
Country Of Origin .....	Taiwan
Warranty .....	1 Year
Serial Number Location .....	Data Label on Machine Body
Customer Assembly & Setup Time .....	1 hour
Sound Rating .....	74 - 77 dB

**Features:**

- Foldable Deflectors
- 3-Stage Filter System
- USA Made Explosion Proof Motor
- Aluminum Impeller
- UL Listed



# Identification

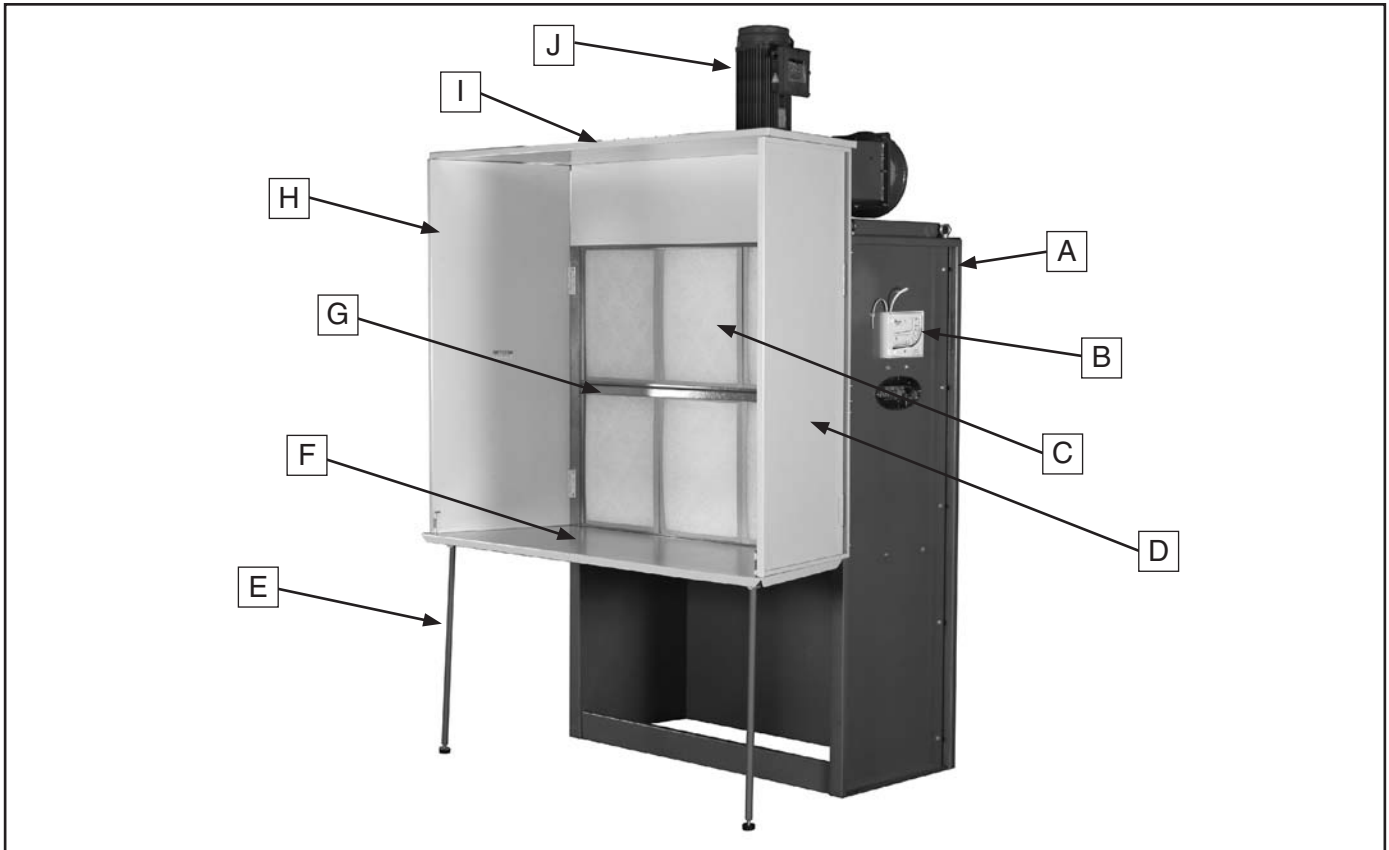

**Figure 1.** G0533 Identification.

- A. Spray Booth Frame
- B. Air Filter Indicator
- C. First Stage Filter
- D. Right Curtain
- E. Work Table Leg
- F. Work Table
- G. Support Bar
- H. Left Curtain
- I. Top Curtain
- J. Motor

# SECTION 1: SAFETY

## **WARNING**

### **For Your Own Safety, Read Instruction Manual Before Operating this Machine**

The purpose of safety symbols is to attract your attention to possible hazardous conditions. This manual uses a series of symbols and signal words intended to convey the level of importance of the safety messages. The progression of symbols is described below. Remember that safety messages by themselves do not eliminate danger and are not a substitute for proper accident prevention measures.



Indicates an imminently hazardous situation which, if not avoided, **WILL** result in death or serious injury.



Indicates a potentially hazardous situation which, if not avoided, **COULD** result in death or serious injury.



Indicates a potentially hazardous situation which, if not avoided, **MAY** result in minor or moderate injury. It may also be used to alert against unsafe practices.

### ***NOTICE***

This symbol is used to alert the user to useful information about proper operation of the machine.

## **WARNING**

### **Safety Instructions for Machinery**

**OWNER'S MANUAL.** Read and understand this owner's manual **BEFORE** using machine. Untrained users can be seriously hurt.

**EYE PROTECTION.** Always wear ANSI-approved safety glasses or a face shield when operating or observing machinery to reduce the risk of eye injury or blindness from flying particles. Everyday eyeglasses are not approved safety glasses.

**HAZARDOUS DUST.** Dust created while using machinery may cause cancer, birth defects, or long-term respiratory damage. Be aware of dust hazards associated with each workpiece material, and always wear a NIOSH-approved respirator to reduce your risk.

**WEARING PROPER APPAREL.** Do not wear clothing, apparel, or jewelry that can become entangled in moving parts. Always tie back or cover long hair. Wear non-slip footwear to avoid accidental slips which could cause a loss of workpiece control.

**HEARING PROTECTION.** Always wear hearing protection when operating or observing loud machinery. Extended exposure to this noise without hearing protection can cause permanent hearing loss.

**MENTAL ALERTNESS.** Be mentally alert when running machinery. Never operate under the influence of drugs or alcohol, when tired, or when distracted.





# WARNING

**DISCONNECTING POWER SUPPLY.** Always disconnect machine from power supply before servicing, adjusting, or changing cutting tools (bits, blades, cutters, etc.). Make sure switch is in OFF position before reconnecting to avoid an unexpected or unintentional start.

**APPROVED OPERATION.** Untrained operators can be seriously hurt by machinery. Only allow trained or properly supervised people to use machine. When machine is not being used, disconnect power, remove switch keys, or lock-out machine to prevent unauthorized use—especially around children. Make workshop kid proof!

**DANGEROUS ENVIRONMENTS.** Do not use machinery in wet or rainy locations, cluttered areas, around flammables, or in poorly-lit areas. Keep work area clean, dry, and well-lighted to minimize risk of injury.

**ONLY USE AS INTENDED.** Only use machine for its intended purpose. Never modify or alter machine for a purpose not intended by the manufacturer or serious injury may result!

**USE RECOMMENDED ACCESSORIES.** Consult this owner's manual or the manufacturer for recommended accessories. Using improper accessories will increase the risk of serious injury.

**CHILDREN & BYSTANDERS.** Keep children and bystanders a safe distance away from work area. Stop using machine if children or bystanders become a distraction.

**REMOVE ADJUSTING TOOLS.** Never leave adjustment tools, chuck keys, wrenches, etc. in or on machine—especially near moving parts. Verify removal before starting!

**SECURING WORKPIECE.** When required, use clamps or vises to secure workpiece. A secured workpiece protects hands and frees both of them to operate the machine.

**FEED DIRECTION.** Unless otherwise noted, feed work against the rotation of blades or cutters. Feeding in the same direction of rotation may pull your hand into the cut.

**FORCING MACHINERY.** Do not force machine. It will do the job safer and better at the rate for which it was designed.

**GUARDS & COVERS.** Guards and covers can protect you from accidental contact with moving parts or flying debris. Make sure they are properly installed, undamaged, and working correctly before using machine.

**NEVER STAND ON MACHINE.** Serious injury or accidental contact with cutting tool may occur if machine is tipped. Machine may be damaged.

**STABLE MACHINE.** Unexpected movement during operations greatly increases the risk of injury and loss of control. Verify machines are stable/secure and mobile bases (if used) are locked before starting.

**AWKWARD POSITIONS.** Keep proper footing and balance at all times when operating machine. Do not overreach! Avoid awkward hand positions that make workpiece control difficult or increase the risk of accidental injury.

**UNATTENDED OPERATION.** Never leave machine running while unattended. Turn machine **OFF** and ensure all moving parts completely stop before walking away.

**MAINTAIN WITH CARE.** Follow all maintenance instructions and lubrication schedules to keep machine in good working condition. An improperly maintained machine may increase the risk of serious injury.

**CHECK DAMAGED PARTS.** Regularly inspect machine for damaged parts, loose bolts, mis-adjusted or mis-aligned parts, binding, or any other conditions that may affect safe operation. Always repair or replace damaged or mis-adjusted parts before operating machine.

**EXPERIENCING DIFFICULTIES.** If at any time you are experiencing difficulties performing the intended operation, stop using the machine! Contact our Technical Support Department at (570) 546-9663.



# **WARNING**

## **Additional Safety Instructions for Dry Spray Booths**

**CODES AND STANDARDS.** Follow all local electrical, safety, and fire codes, National Fire Protection Association codes, the National Electrical Code, and the Occupational Safety and Health Act. Install your spray booth according to NFPA 33 and NEC 2005 standards.

**EXHAUST FAN.** Before using the spray booth, turn the exhaust fan **ON** and make sure it is operating correctly.

**BOOTH INTERLOCK.** A booth interlock, which disables spraying devices unless the exhaust fan is operating, may be required by local codes.

**RESPIRATOR.** Use an OSHA-approved paint spray respirator when spraying in the booth.

**FILTER PAD REPLACEMENT.** Do not operate the spray booth when the air filter indicator indicates the filter pad needs to be replaced.

**MOTOR TYPE.** Motors are for use in Class I, Division 1, Group D Hazardous Locations and should be installed in areas where paints, solvents and other materials are for Group D only.

**FLAMMABLE MATERIAL DISPOSAL.** Safely and properly dispose used filters or paint-contaminated items.

**DUCTING EXHAUST.** Do not operate the spray booth unless exhaust air has been properly ducted away from the work area to the outdoors using 20 gauge spiral welded or 18 gauge rolled galvanized steel ducts, lapped in the direction of the air flow, and using steel fasteners only.

**RECIRCULATING EXHAUST.** Do not place the exterior exhaust vent near air conditioning intakes, windows, or anything else that may recirculate exhaust indoors.

**VOC REDUCTION.** This spray booth is designed to only remove particulate matter. Additional optional equipment or coating reformulation will be necessary to reduce volatile organic compounds.

**FIRE PROTECTION.** This spray booth must be protected by an approved automatic fire protection system in accordance with Chapter 7 of NFPA 33.

### **WARNING**

Like all machinery there is potential danger when operating this machine. Accidents are frequently caused by lack of familiarity or failure to pay attention. Use this machine with respect and caution to decrease the risk of operator injury. If normal safety precautions are overlooked or ignored, serious personal injury may occur.

### **CAUTION**

No list of safety guidelines can be complete. Every shop environment is different. Always consider safety first, as it applies to your individual working conditions. Use this and other machinery with caution and respect. Failure to do so could result in serious personal injury, damage to equipment, or poor work results.



# SECTION 2: POWER SUPPLY

## Availability

Before installing the machine, consider the availability and proximity of the required power supply circuit. If an existing circuit does not meet the requirements for this machine, a new circuit must be installed. To minimize the risk of electrocution, fire, or equipment damage, installation work and electrical wiring must be done by a qualified electrician in accordance with all applicable codes and standards.

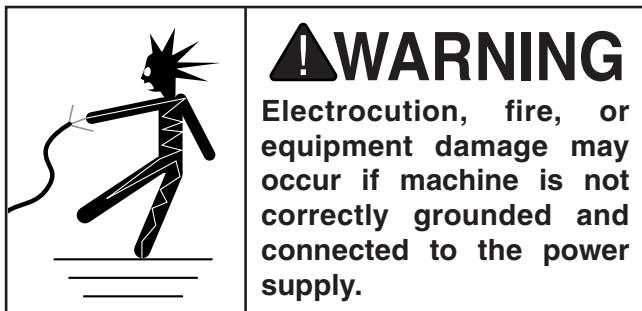

## Full-Load Current Rating

The full-load current rating is the amperage a machine draws at 100% of the rated output power. On machines with multiple motors, this is the amperage drawn by the largest motor or sum of all motors and electrical devices that might operate at one time during normal operations.

### Full-Load Current Rating at 230V ..... 15 Amps

The full-load current is not the maximum amount of amps that the machine will draw. If the machine is overloaded, it will draw additional amps beyond the full-load rating.

If the machine is overloaded for a sufficient length of time, damage, overheating, or fire may result—especially if connected to an undersized circuit. To reduce the risk of these hazards, avoid overloading the machine during operation and make sure it is connected to a power supply circuit that meets the requirements in the following section.

## Circuit Requirements for 230V

This machine is prewired to operate on a 230V power supply circuit that has a verified ground and meets the following requirements:

**Nominal Voltage** ..... 220V/240V  
**Cycle** ..... 60 Hz  
**Phase** ..... 1-Phase  
**Circuit Rating** ..... 20 Amps

A power supply circuit includes all electrical equipment between the breaker box or fuse panel in the building and the machine. The power supply circuit used for this machine must be sized to safely handle the full-load current drawn from the machine for an extended period of time. (If this machine is connected to a circuit protected by fuses, use a time delay fuse marked D.)



**Note:** *The circuit requirements listed in this manual apply to a dedicated circuit—where only one machine will be running at a time. If this machine will be connected to a shared circuit where multiple machines will be running at the same time, consult a qualified electrician to ensure that the circuit is properly sized for safe operation.*

## Connection Type

We recommend that you hardwire the dry spray booth directly to your circuit breaker. The ON/OFF switch must be installed a minimum of 10 feet from the booth unless specified for hazardous locations per NFPA 33 and NEC 2005.

It is the customer's responsibility to install wiring and a switch in the G0533. Because of the fire/explosion hazard potential of spray booths, you MUST have a qualified electrician connect the switch to the motor and hardwire the switch to a power source per NFPA 33 and NEC regulations, as well as all local and state regulations governing spray booths. Consult your local fire department for more information.



# SECTION 3: SET UP

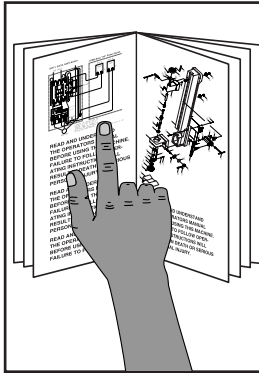

## **!WARNING**

This machine presents serious injury hazards to untrained users. Read through this entire manual to become familiar with the controls and operations before starting the machine!

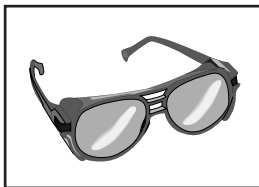

## **!WARNING**

Wear safety glasses during the entire setup process!

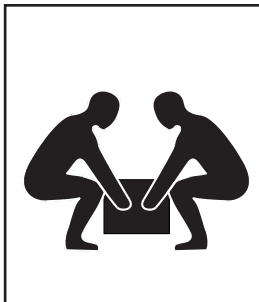

## **!WARNING**

This machine and its components are very heavy. Get lifting help or use power lifting equipment such as a forklift to move heavy items.

## Needed for Set Up

The following items are needed to complete the set up process, but are not included with your machine:

DESCRIPTION	Qty
• Assistants .....	2
• Hoist .....	1
• Safety Glasses (for each person) .....	1
• Phillips Head Screwdriver .....	1
• Open-End Wrench $\frac{7}{16}$ " .....	1
• Open-End Wrench $\frac{1}{2}$ " .....	1
• Ducting (length as needed, <b>Page 16</b> ) .....	1
• Switch and Wiring ..... (As per NFPA 33 and NEC regulations)	

## Unpacking

Your machine was carefully packaged for safe transportation. Remove the packaging materials from around your machine and inspect it. If you discover the machine is damaged, *please immediately call Customer Service at (570) 546-9663 for advice.*

Save the containers and all packing materials for possible inspection by the carrier or its agent. *Otherwise, filing a freight claim can be difficult.*

When you are completely satisfied with the condition of your shipment, inventory the contents.

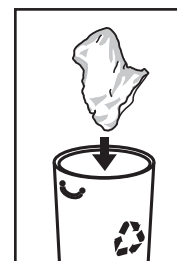

## **!WARNING**

### **SUFFOCATION HAZARD!**

Keep children and pets away from plastic bags or packing materials unpacked with this machine. Discard immediately.



# Inventory

The following is a description of the main components shipped with your machine. Lay the components out to inventory them.

If any non-proprietary parts are missing (e.g. a nut or a washer), we will gladly replace them; or for the sake of expediency, replacements can be obtained at your local hardware store.

<b>Shipping Inventory (Figure 2)</b>	<b>Qty</b>
A. Spray Booth.....	1
B. Curtain (Right) .....	1
C. Connector Bars .....	2
D. Air Filter Indicator (Manometer).....	1
E. Support Bar .....	1
F. Work Table .....	1
G. First Stage Filters .....	6
H. Second Stage Filters.....	6
I. Third Stage Filters.....	6
J. Outlet.....	1
K. Exhaust Fan .....	1
L. Curtain (Left) .....	1
M. Curtain (Upper).....	1
N. Curtain Brace (Left).....	1
O. Curtain Brace (Right).....	1

## Hardware and Tools (Not Shown)

- Hex Bolts  $\frac{5}{16}$ "-18 x 1" (Exhaust Fan, Outlet) 18
- Flat Washers  $\frac{5}{16}$ " (Exhaust Fan, Outlet)..... 28
- Inlet Gasket (Exhaust Fan) .....
- Outlet Gasket (Outlet) .....
- Hex Nuts  $\frac{5}{16}$ "-18 (Outlet) .....
- Flat Hd Screws  $\frac{1}{4}$ "-20 x  $\frac{5}{8}$ "  
(Support Bar, Curtains, Work Table) .....
- Hex Nuts  $\frac{1}{4}$ "-20  
(Support Bar, Curtains, Work Table).....
- Flat Washers  $\frac{1}{4}$ "  
(Support Bar, Curtains, Work Table).....
- Hex Bolts  $\frac{5}{16}$ "-18 x  $\frac{3}{4}$ " (Curtains).....
- Tubing (Manometer) .....
- Tubing Connector Fitting (Manometer).....
- Plastic Clip (Manometer) .....
- Tap Screw M4 x 12 (Manometer) .....
- Tap Screws M4 x 45 (Manometer) .....
- Red Gauge Oil (Manometer) .....
- Arrow Labels (Red and Green) .....

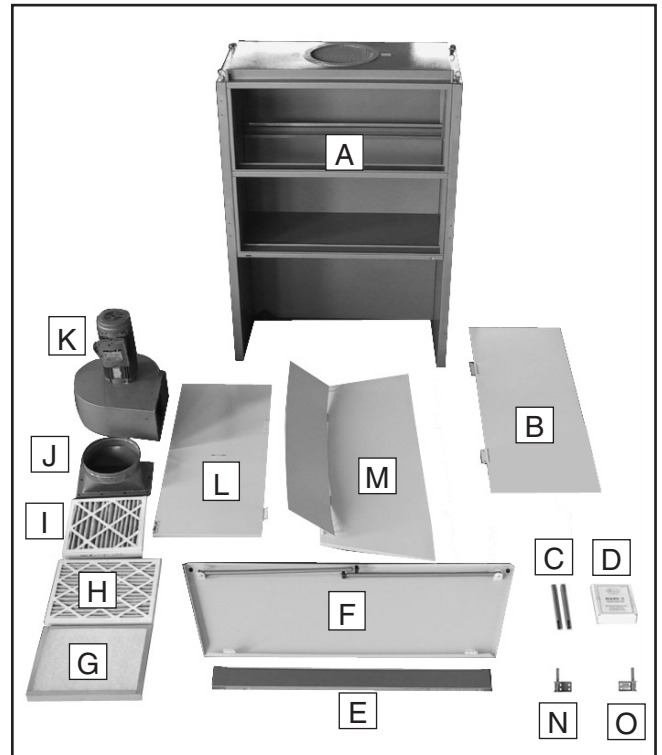

Figure 2. G0533 Inventory.

## NOTICE

If you cannot find an item on this list, check the mounting location on the machine or the packaging materials. Sometimes parts are pre-installed for shipping, or they become hidden by packaging materials.





# Hardware Recognition Chart

USE THIS CHART TO MATCH UP HARDWARE DURING THE ASSEMBLY PROCESS.

MEASURE BOLT DIAMETER BY PLACING INSIDE CIRCLE

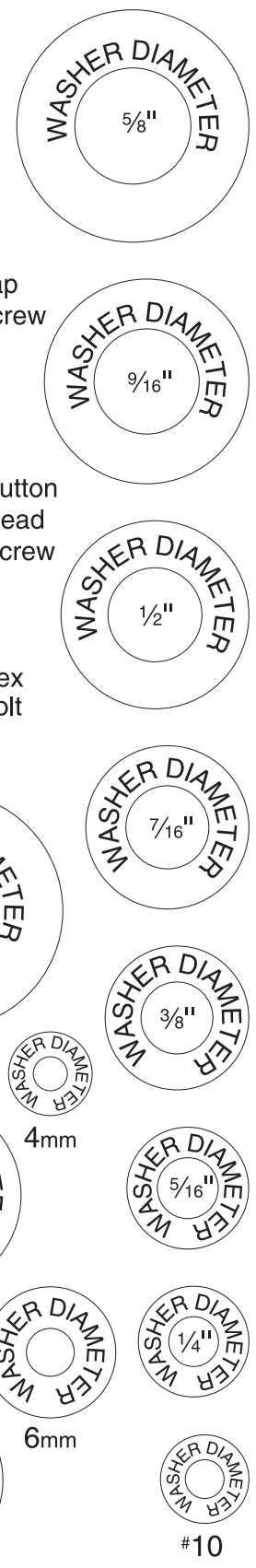
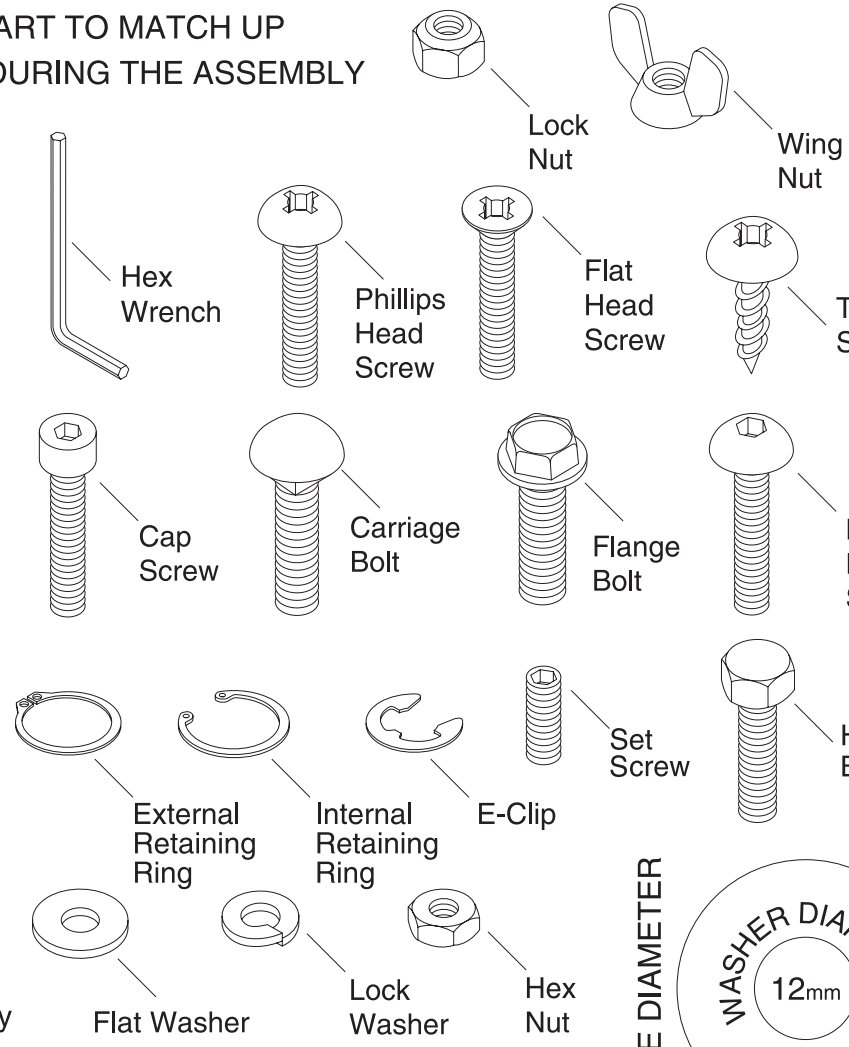
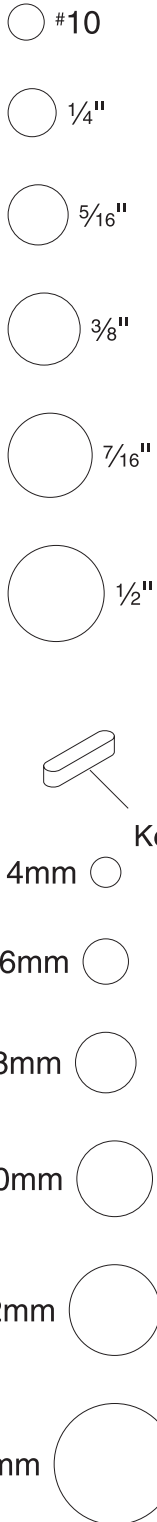

WASHERS ARE MEASURED BY THE INSIDE DIAMETER



# Site Considerations

## Floor Load

Refer to the **Machine Data Sheet** for the weight and footprint specifications of your machine. Some floors may require additional reinforcement to support both the machine and operator.

## Working Clearances

Consider existing and future needs, size of material to be processed through each machine, and space for auxiliary stands, work tables or other machinery when establishing a location for your new machine. Make a note of the exhaust fan location. (See **Safety on Page 8.**) See **Figure 3** for the minimum working clearances.

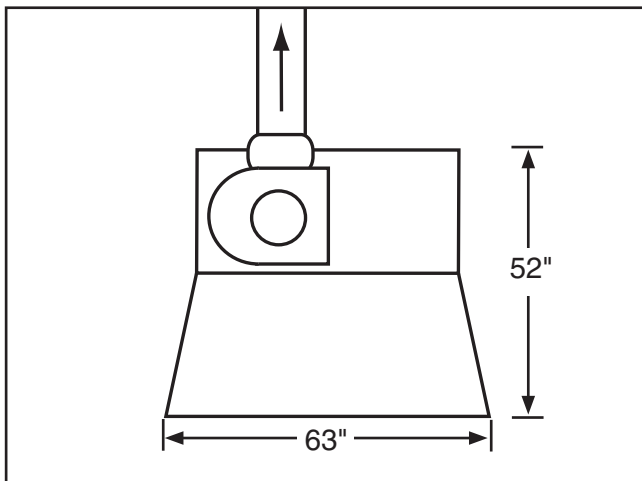

**Figure 3.** Minimum working clearances (top view).



# Exhaust Fan

To install the exhaust fan housing:

1. Place the inlet gasket over the exhaust fan inlet.



2. With the help of two strong assistants, or using a hoist, place the exhaust fan housing over the inlet gasket.
3. Rotate the exhaust fan housing so the outlet port is aimed toward the back of the spray booth.
4. Align the gasket and exhaust fan mounting holes, and fasten with eight  $\frac{5}{16}$ "-18 x 1" hex bolts and flat washers, as shown in **Figure 4**.

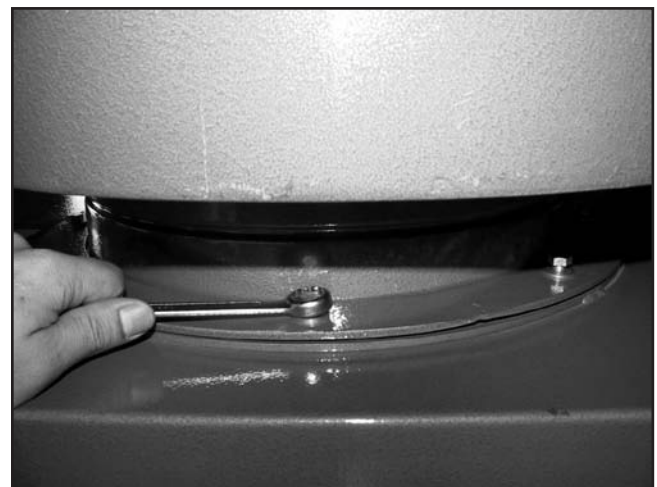
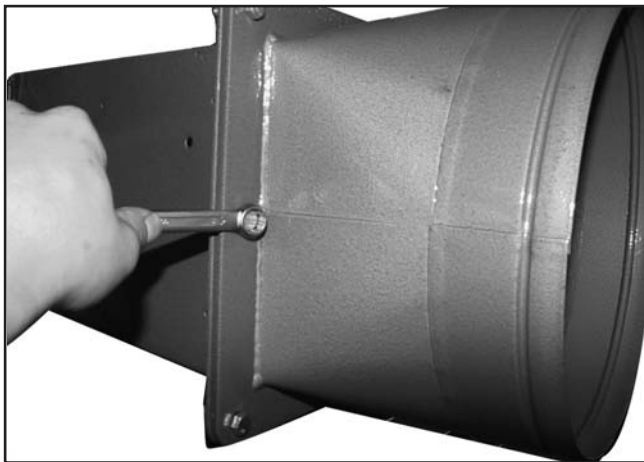

**Figure 4.** Installing exhaust fan onto spray booth.

# Outlet

## To install the exhaust fan outlet:

1. Place the outlet gasket and outlet over the exhaust fan, and secure with (10)  $\frac{5}{16}$ "-18 x 1" hex bolts, 20 flat washers, and 10 hex nuts, as shown in **Figure 5**.



**Figure 5.** Installing outlet.

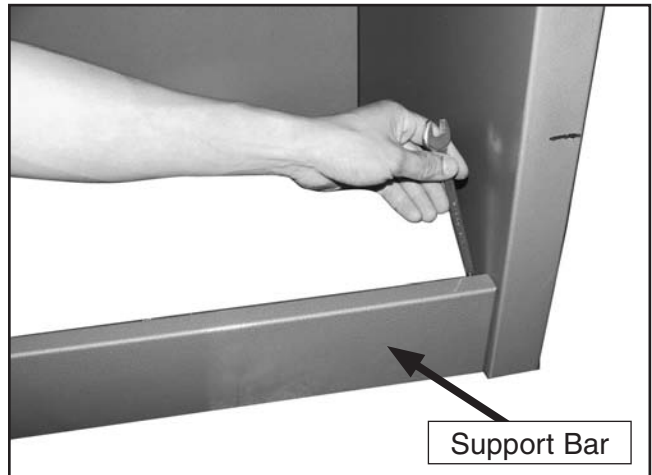
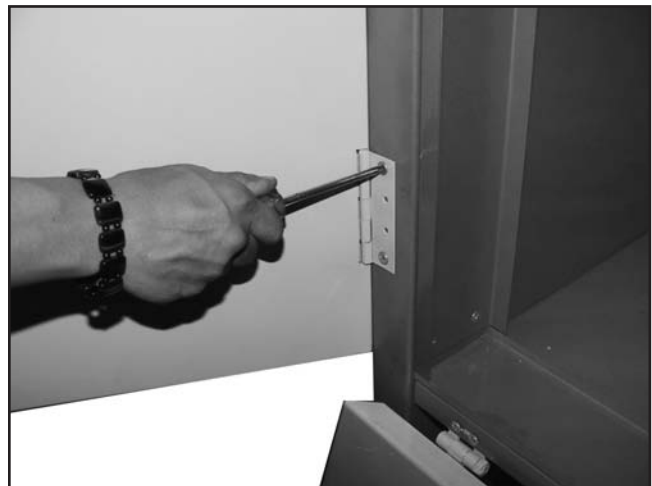

**Figure 6.** Support bar installed.

# Curtains

## To install the curtains:

1. Fasten the hinges (**Figure 7**) of the left curtain to the front left side of the spray booth, each with two  $\frac{1}{4}$ "-20 x  $\frac{5}{8}$ " flat head screws, flat washers and hex nuts.



**Figure 7.** Installing left curtain.

# Support Bar

## To install the support bar:

1. Place the support bar between the lower right and left edges of the spray booth (**Figure 6**), and fasten each side with two  $\frac{1}{4}$ "-20 x  $\frac{5}{8}$ " flat head screws, two flat washers, and two hex nuts.



2. Repeat **Step 1** with the right curtain.
3. Fasten each curtain brace to the top cover with four  $\frac{5}{16}$ "-18 x  $\frac{3}{4}$ " hex bolts as shown in **Figure 8**.

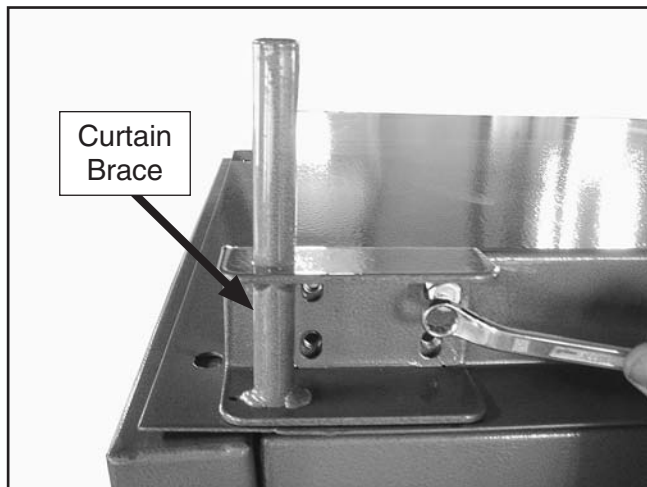

**Figure 8.** Installing curtain brace.

4. Insert a connector bar into the socket on each curtain brace, as shown in **Figure 9**.

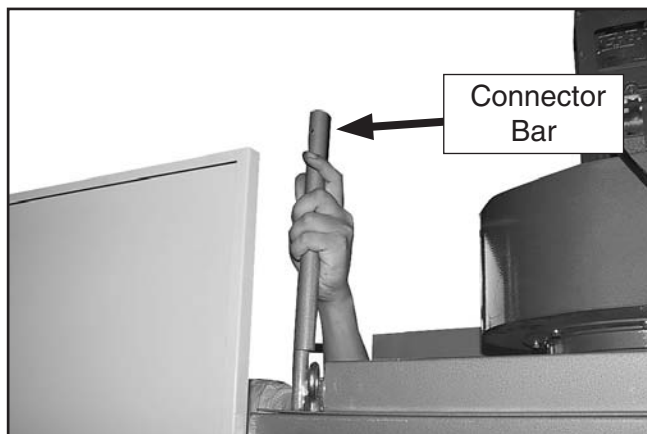

**Figure 9.** Inserting connector bar.

5. Insert the sockets on the top curtain into the connector bars, as shown in **Figure 10**.



**Figure 10.** Top curtain attached to connector bar.

## Work Table

### To install the work table:

1. Fasten each of the work table hinges to the spray booth with two  $\frac{1}{4}$ "-20 x  $\frac{5}{8}$ " flat head screws, flat washers, and hex nuts as shown in **Figure 11**.



**Figure 11.** Installing table.

2. Make sure the work table opens and closes smoothly.
3. Reach under the work table and fully extend the two support legs.
4. Lock the latches on the bottom of each curtain into the work table.

## Filters

### To install the filters:

1. Install the six third stage filters into the filter case as shown in **Figure 12**.

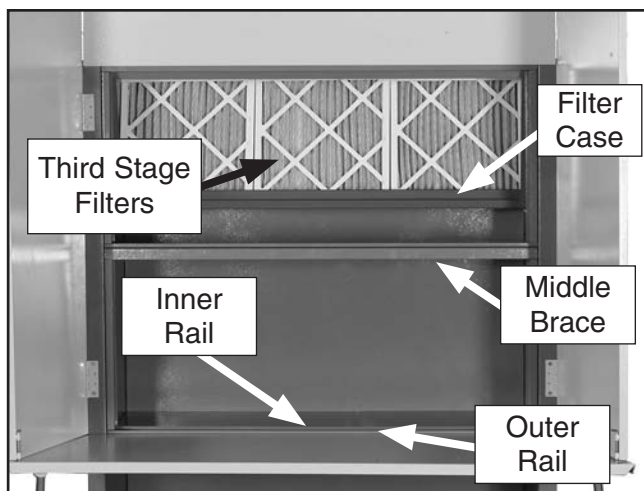

**Figure 12.** Third stage filters (only three shown).

2. Install six second-stage filters above and below the middle brace along the inner rails, as shown in **Figure 13**.



**Figure 13.** Second-stage filters.

3. Install six first stage filters (**Figure 14**) along the outer rails.



**Figure 14.** First stage filters.

## Ducting

The G0533 dry spray booth must be vented to the outside of your shop or building using 12" metal spiral wound ducting or 18 gauge rolled galvanized steel ducts in accordance with NFPA 33 guidelines.

# Air Filter Indicator

## To install the air filter indicator:

1. Mount the manometer to the side of the spray booth by threading the M4 x 45 tap screws into the pre-drilled holes (**Figure 15**).

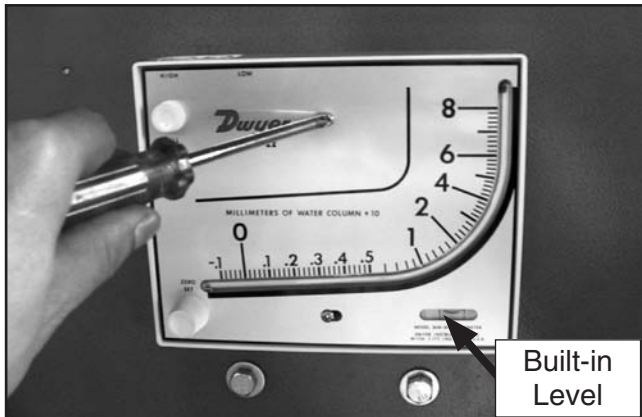

**Figure 15.** Mounting manometer to spray booth.

2. Adjust the manometer so the built-in level reads level (**Figure 15**).
3. Install a tubing connector fitting in the larger pre-drilled hole on the side of the booth near the manometer as shown in **Figure 16**.

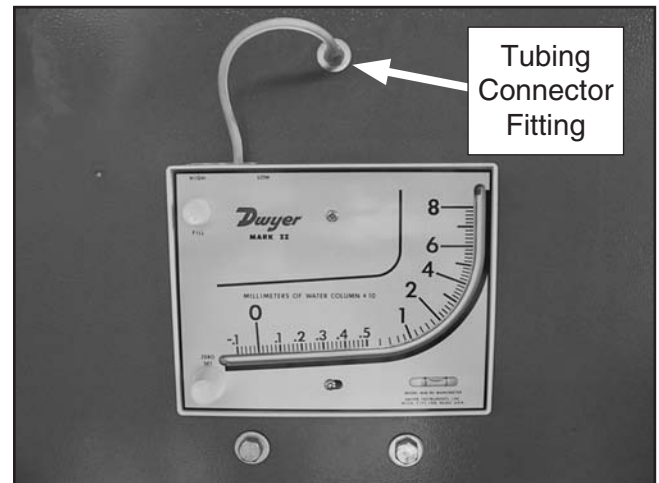

**Figure 16.** Tubing installed onto spray booth chamber.

4. Run tubing from the low pressure side (-) of the manometer to the tubing connector fitting as shown in **Figure 16**.
5. Install tubing into the high pressure side (+) of the manometer and secure it with the plastic clip and an M4 x 12 tap screw as shown in **Figure 17**.

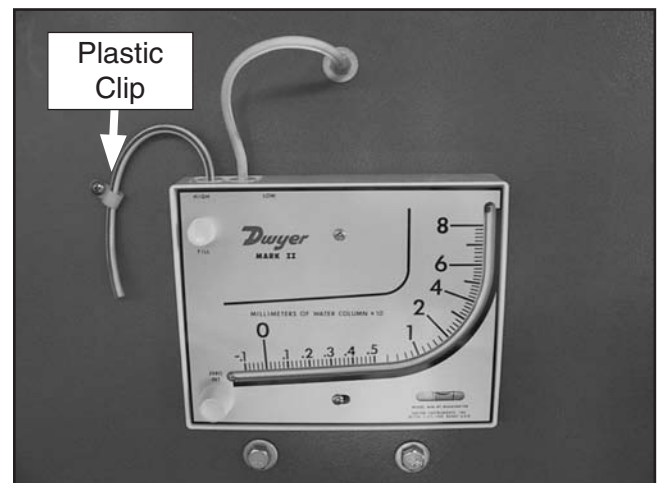
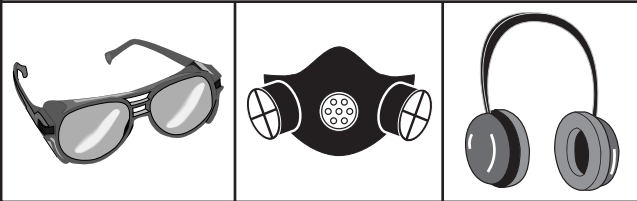

**Figure 17.** Tubing secured with clip.

# SECTION 4: OPERATIONS

## ! WARNING

Damage to your eyes, lungs, and ears could result from using this machine without proper protective gear. Always wear safety glasses, a respirator, and hearing protection when operating this machine.



## ! WARNING

Loose hair and clothing could get caught in machinery and cause serious personal injury. Keep loose clothing and long hair away from moving machinery.

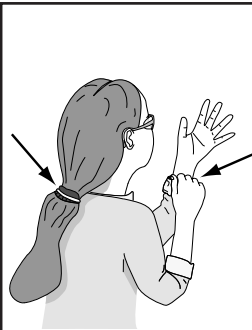

## NOTICE

If you have never used this type of machine or equipment before, WE STRONGLY RECOMMEND that you read books, trade magazines, or get formal training before beginning any projects. Regardless of the content in this section, Grizzly Industrial will not be held liable for accidents caused by lack of training, neglect or misuse.

## Filter Indicator

**NOTICE:** Never operate the spray booth without all of the air filters installed!

To fill the air filter indicator (manometer):

1. Turn the spray booth **OFF**!
2. DISCONNECT THE POWER!
3. Check to make sure the manometer body is level. Adjust as needed.
4. Rotate the zero adjustment knob counter-clockwise (**Figure 18**) until it stops, then turn it clockwise three turns.

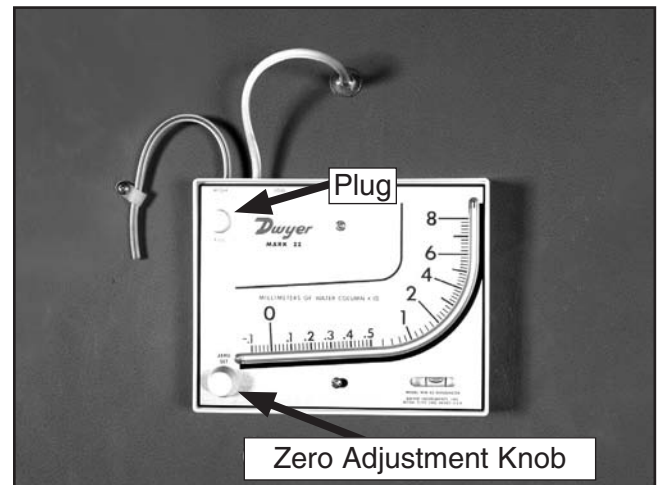

**Figure 18.** Air filter indicator controls.

5. Remove the plug (**Figure 18**) and fill the chamber with the included red gauge oil until the fluid level reaches zero on the indicator. Minor fluid level adjustments can be made using the zero adjustment knob.

**Note:** Only use Dwyer® red gauge oil to fill the manometer. If you need additional oil, order Grizzly part number P0533062.



6. With new filters installed, turn the spray booth **ON**, observe the rise in the reading, and mark with the supplied green arrow as shown in the example in **Figure 19**.



**Figure 19.** New filter installation mark example.

7. Multiply the reading from **Step 6** times 2 (2x) and mark with the supplied red arrow (**Figure 20**). This is the dirty filter indicator mark. When the fluid reaches the red arrow, install new filters.



**Figure 20.** Dirty filter mark example.

**Note:** Always make sure the fluid level is at zero before using the spray booth each time. Also, check the fluid level on a regular basis and re-fill as needed.



# SECTION 5: MAINTENANCE

---

---

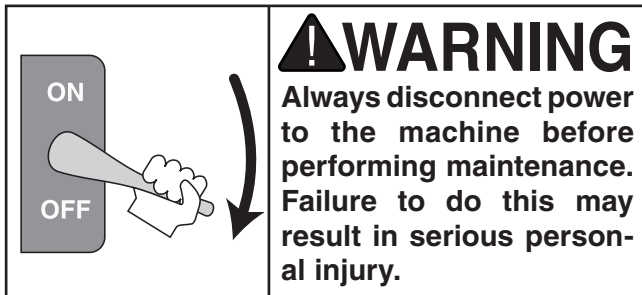

## Schedule

---

---

How often you perform maintenance checks depends upon the material type and amount being sprayed. Checking at regular intervals can reduce fire hazards, maintain spray booth efficiency, prevent newly painted objects from blemishing, and hinder rust.

## Exhaust Fan and Motor

---

---

Do not allow paint overspray to build up on the exhaust fan, as overspray deposits will hinder booth airflow. Remove overspray deposits as soon as possible with heavy-duty paint remover to keep the fan in balance. Remove and clean the fan as needed, but do not hammer or step on the fan, as it could be easily damaged. Always disconnect the machine from the power source, and turn **OFF** the breaker before accessing the fan compartment.

Never operate the exhaust fan without ducting installed.

## Ducting

---

---

Do not allow overspray to build up inside duct walls. Remove overspray as soon as possible with heavy-duty paint remover, when it builds up, to prevent a possible fire hazard.

## Air Filter Indicator

---

---

Check the air filter indicator fluid level periodically and refill as needed with Dwyer® red gauge oil. Clean the indicator with a soft, damp cloth.

## Interior Booth Walls

---

---

Do not allow overspray to build up on inner booth walls. Remove overspray deposits as soon as possible to prevent a possible fire hazard. Use a non-ferrous, non-sparking scraper to eliminate the possibility of igniting combustible material. Do not leave heaps of paint sweepings in the booth, as these could also cause a fire hazard.

The following products, which are available from a variety of manufacturers, can make it easier to keep the booth clean: special flame-resistant paper, a pre-coating, or clear peel. Consult the product manufacturer for more information about product installation.

## Exhaust Filters

---

---

Replace filters when the filter indicator shows they need to be changed.

The following replacement filters are available for the Model G0533:

- H5837, 30 micron first stage filter
- H5838, 10 micron second stage filter
- H5839, 5 micron third stage filter

Immediately remove used filters from the booth. Place them in a safe location far away from the booth, or place in a water-filled metal container to prevent a fire hazard. Disposal varies depending on the type of paint being captured. Consult local authorities for storage and disposal recommendations.



# SECTION 6: SERVICE

Review the troubleshooting and procedures in this section to fix or adjust your machine if a problem develops. If you need replacement parts or you are unsure of your repair skills, then feel free to call our Technical Support at (570) 546-9663.

## Troubleshooting

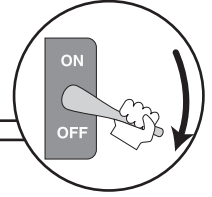

### Motor and Electrical

SYMPTOM	POSSIBLE CAUSE	POSSIBLE SOLUTION
Reduced performance with new filters.	1. Paint build-up on exhaust fan blades or exhaust duct.	1. Check exhaust fan blades and exhaust duct and, if needed, clean with heavy-duty paint remover.
Motor producing unusual noise or vibrations.	1. Motor mounting hardware loose or fan loose.	1. Tighten motor mounting hardware. Tighten fan.

### Spray Booth Operations

SYMPTOM	POSSIBLE CAUSE	POSSIBLE SOLUTION
Too little airflow in booth.	1. The filter is dirty. 2. Obstructions exist in front of the filters. 3. Filters do not meet design specifications. 4. Fan is dirty. 5. Filters not installed correctly.	1. Change the filters. 2. Remove obstructions. 3. Change filters to meet correct specifications. 4. Clean fan. 5. Make sure all filters are installed and properly seated.
Too much airflow in booth.	1. Filters are not correctly seated.	1. Make sure all filters are installed and properly seated.
The filter indicator does not work properly.	1. Fluid level is low. 2. Obstructions exist in hoses. 3. Air filter indicator is not level.	1. Check fluid level and add fluid as needed. 2. Remove obstructions from hoses. 3. Loosen manometer mounting hardware, level using sight glass, and tighten mounting hardware.



# G0533 Wiring Diagram

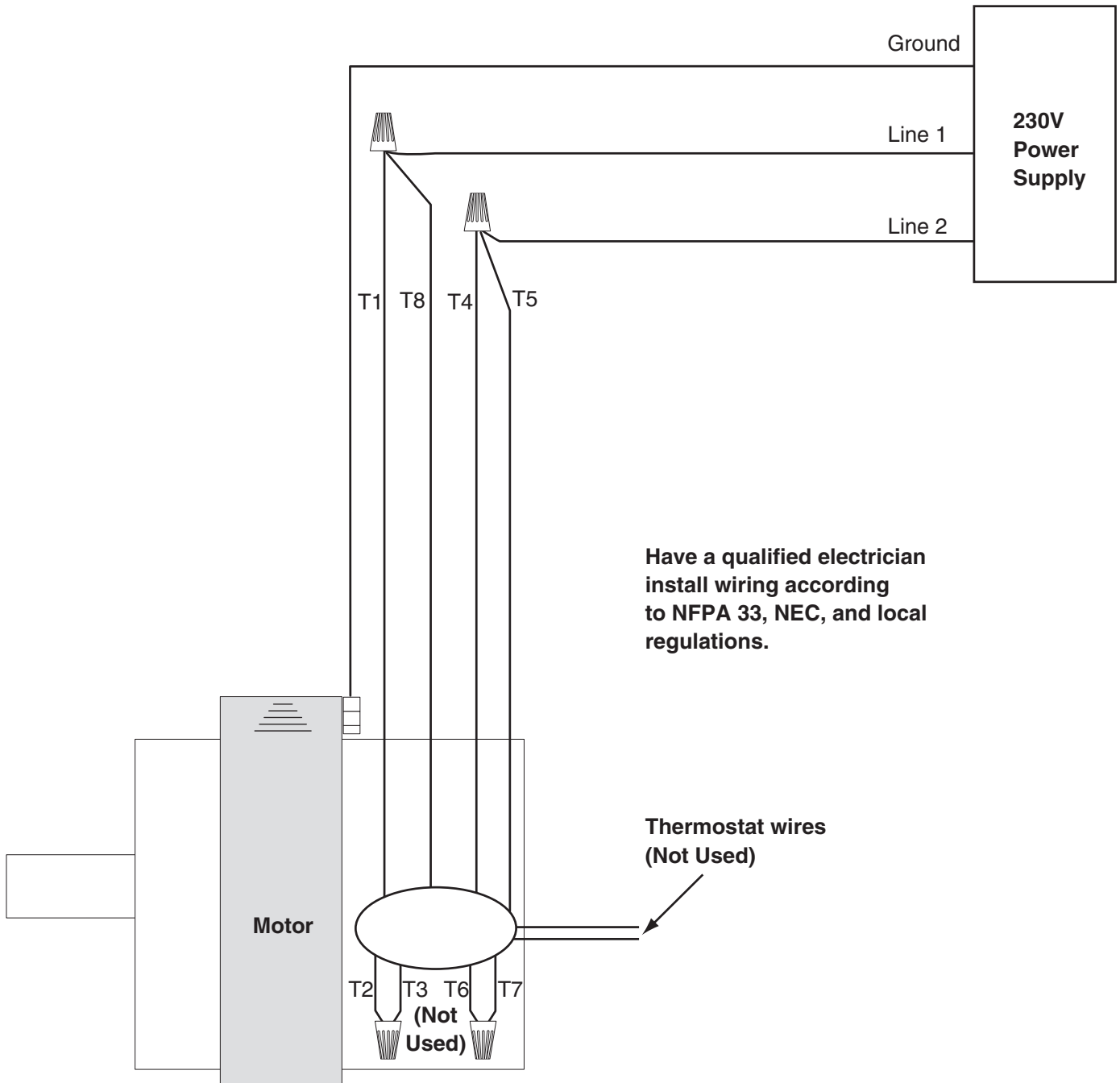



# Main Parts Breakdown

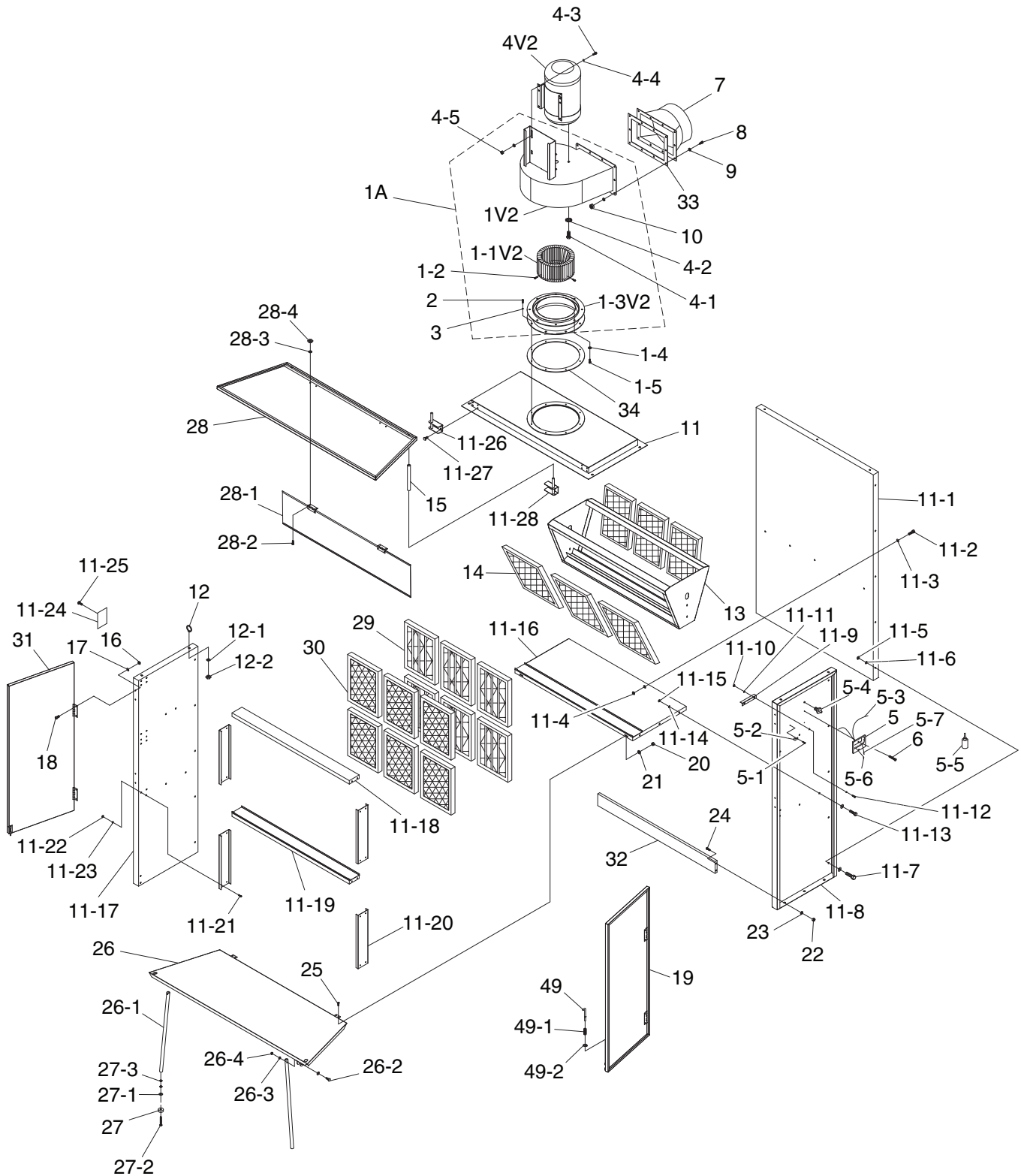

# Main Parts List

REF	PART #	DESCRIPTION
1AV2	P0533001AV2	BLOWER HOUSING ASSY V2.03.11
1V2	P0533001V2	BLOWER HOUSING V2.03.11
1-1V2	P0533001-1V2	IMPELLER 12" V2.03.11
1-2	PB21	HEX BOLT 3/8-16 X 3/4
1-3V2	P0533001-3V2	INTAKE PORT V2.03.11
1-4	PW07	FLAT WASHER 5/16
1-5	PB07	HEX BOLT 5/16-18 X 3/4
2	PB03	HEX BOLT 5/16-18 X 1
3	PW07	FLAT WASHER 5/16
4V2	P0533004V2	MOTOR 3HP 230V 1PH T3C V2.03.11
4-1	PB52	HEX BOLT 1/2-13 X 1
4-2	PTLW04	EXT TOOTH WASHER 1/2
4-3	PB18	HEX BOLT 3/8-16 X 1
4-4	PW02	FLAT WASHER 3/8
4-5	PN08	HEX NUT 3/8-16
5	P0533005	AIR FILTER INDICATOR
5-1	PHTEK39M	TAP SCREW M4 X 12
5-2	P0533005-2	CLIP PLASTIC
5-3	P0533005-3	TUBING
5-4	P0533005-4	TUBING CONNECTOR FITTING
5-5	P0533005-5	RED GAUGE OIL
5-6	P0533005-6	RED ARROW
5-7	P0533005-7	GREEN ARROW
6	PHTEK46M	TAP SCREW M4 X 45
7	P0533007	OUTLET 12"
8	PB03	HEX BOLT 5/16-18 X 1
9	PW07	FLAT WASHER 5/16
10	PN02	HEX NUT 5/16-18
11	P0533011	COVER TOP
11-1	P0533011-1	BACK COVER
11-2	PB21	HEX BOLT 3/8-16 X 3/4
11-3	PW02	FLAT WASHER 3/8
11-4	PN08	HEX NUT 3/8-16
11-5	PN08	HEX NUT 3/8-16
11-6	PW02	FLAT WASHER 3/8
11-7	PB21	HEX BOLT 3/8-16 X 3/4
11-8	P0533011-8	COVER RIGHT
11-9	P0533011-9	FILTER CASE BRACE
11-10	PN02	HEX NUT 5/16-18
11-11	PW07	FLAT WASHER 5/16
11-12	PB07	HEX BOLT 5/16-18 X 3/4
11-13	PB21	HEX BOLT 3/8-16 X 3/4
11-14	PW02	FLAT WASHER 3/8
11-15	PN08	HEX NUT 3/8-16
11-16	P0533011-16	FILTER CASE BASE
11-17	P0533011-17	COVER LEFT
11-18	P0533011-18	TOP FILTER CASE SUPPORT
11-19	P0533011-19	FILTER CASE SUPPORT MIDDLE

REF	PART #	DESCRIPTION
11-20	P0533011-20	SIDE FILTER CASE SUPPORT
11-21	PHTEK34	TAP SCREW 1/4 X 1/2
11-22	PN05	HEX NUT 1/4-20
11-23	PW06	FLAT WASHER 1/4 IN
11-24	P0533011-24	SWITCH BASE
11-25	PHTEK39M	TAP SCREW M4 X 12
11-26	P0533011-26	CURTAIN BRACE LEFT
11-27	PB07	HEX BOLT 5/16-18 X 3/4
11-28	P0533011-28	CURTAIN BRACE RIGHT
12	P0533012	HOOK 3/8-16
12-1	PW02	FLAT WASHER 3/8
12-2	PN08	HEX NUT 3/8-16
13	P0533013	FILTER CASE
14	P0533014	5 MICRON THIRD STAGE FILTER
15	P0533015	CONNECTOR BAR
16	PN05	HEX NUT 1/4-20
17	PW06	FLAT WASHER 1/4 IN
18	PFH04	FLAT HD SCR 1/4-20 X 5/8
19	P0533019	RIGHT STEEL CURTAIN
20	PN05	HEX NUT 1/4-20
21	PW06	FLAT WASHER 1/4 IN
22	PN05	HEX NUT 1/4-20
23	PW06	FLAT WASHER 1/4 IN
24	PFH04	FLAT HD SCR 1/4-20 X 5/8
25	PFH04	FLAT HD SCR 1/4-20 X 5/8
26	P0533026	WORK TABLE
26-1	P0533026-1	WORK TABLE LEG
26-2	PB06	HEX BOLT 5/16-18 X 2
26-3	PW07	FLAT WASHER 5/16
26-4	PN02	HEX NUT 5/16-18
27	P0533027	LEG CUSHION 3/8"
27-1	PW02	FLAT WASHER 3/8
27-2	PB60	HEX BOLT 3/8-16 X 3
27-3	PN08	HEX NUT 3/8-16
28	P0533028	CURTAIN TOP STEEL
28-1	P0533028-1	CURTAIN TOP SMALL
28-2	PHTEK34	TAP SCREW 1/4 X 1/2
28-3	PW06	FLAT WASHER 1/4 IN
28-4	PN05	HEX NUT 1/4-20
29	H5838	10 MICRON SECOND STAGE FILTER
30	H5837	30 MICRON FIRST STAGE FILTER
31	P0533031	LEFT STEEL CURTAIN
32	P0533032	SUPPORT BAR
33	P0533033	OUTLET GASKET
34	P0533034	INLET GASKET
49	P0533049	DOOR LATCH PIN
49-1	P0533049-1	COMPRESSION SPRING
49-2	P0533049-2	SPRING RETAINER



# Safety Label Placement and Parts List

## ⚠️ WARNING

Safety labels help reduce the risk of serious injury caused by machine hazards. If any label comes off or becomes unreadable, the owner of this machine **MUST** replace it in the original location before resuming operations. For replacements, contact (800) 523-4777 or [www.grizzly.com](http://www.grizzly.com).

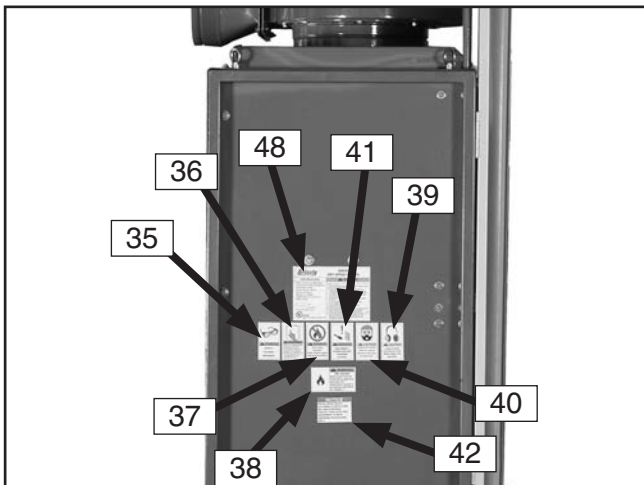
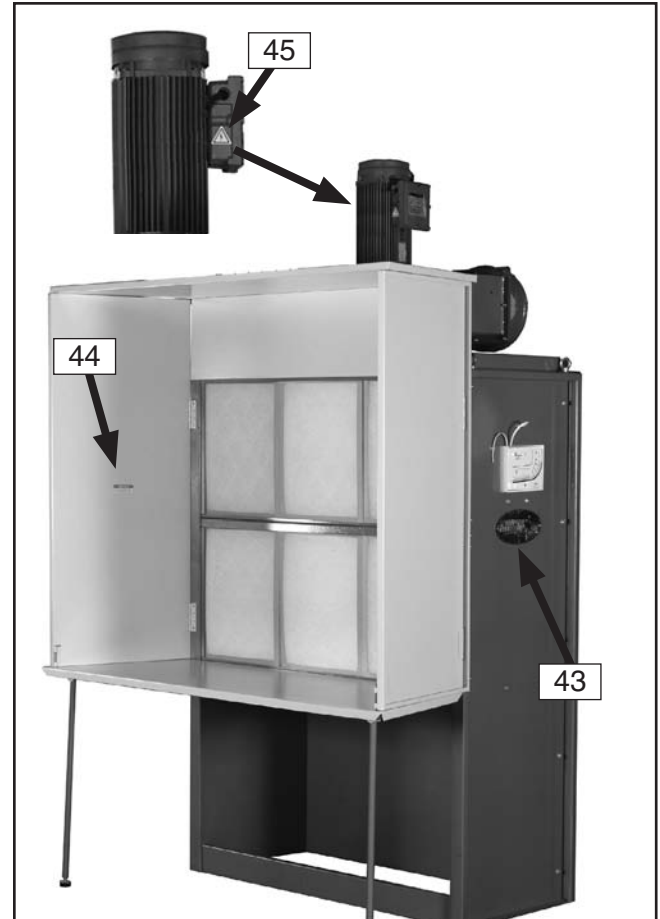
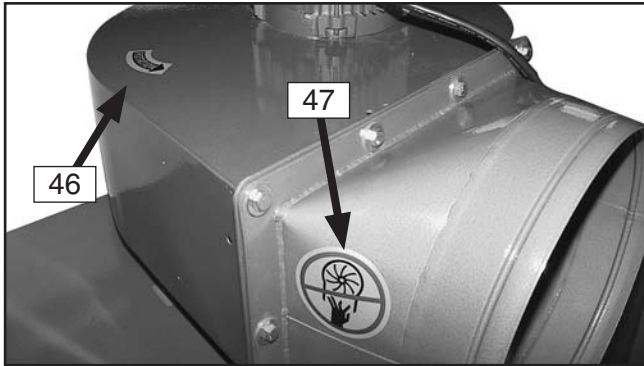

REF	PART #	DESCRIPTION
35	PLABEL-11	SAFETY GLASSES VL
36	PLABEL-12A	READ MANUAL VL
37	P0532068	EXPLOSION HAZARD LABEL
38	P0532063	FIRE HAZARD LABEL
40	PLABEL-15	EAR PROTECTION VL
41	P0533041	UNPLUG FILTER CHANGE LABEL
42	P0532067	NOTICE REGULATIONS LABEL

REF	PART #	DESCRIPTION
43	G8589	GRIZZLY NAMEPLATE-LARGE
44	P0532074	NOTICE FILTERS LABEL
45	PLABEL-14	ELECTRICITY
46	P0532073	ROTATION DIRECTION LABEL
47	P0533047	IMPELLER HAZARD LABEL
48	P0533048	MACHINE ID LABEL







# WARRANTY CARD

Name \_\_\_\_\_  
 Street \_\_\_\_\_  
 City \_\_\_\_\_ State \_\_\_\_\_ Zip \_\_\_\_\_  
 Phone # \_\_\_\_\_ Email \_\_\_\_\_ Invoice # \_\_\_\_\_  
 Model # \_\_\_\_\_ Order # \_\_\_\_\_ Serial # \_\_\_\_\_

The following information is given on a voluntary basis. It will be used for marketing purposes to help us develop better products and services. **Of course, all information is strictly confidential.**

1. How did you learn about us?
 

<input type="checkbox"/> Advertisement	<input type="checkbox"/> Friend	<input type="checkbox"/> Catalog
<input type="checkbox"/> Card Deck	<input type="checkbox"/> Website	<input type="checkbox"/> Other:
  
2. Which of the following magazines do you subscribe to?
 

<input type="checkbox"/> Cabinetmaker & FDM	<input type="checkbox"/> Popular Science	<input type="checkbox"/> Wooden Boat
<input type="checkbox"/> Family Handyman	<input type="checkbox"/> Popular Woodworking	<input type="checkbox"/> Woodshop News
<input type="checkbox"/> Hand Loader	<input type="checkbox"/> Precision Shooter	<input type="checkbox"/> Woodsmith
<input type="checkbox"/> Handy	<input type="checkbox"/> Projects in Metal	<input type="checkbox"/> Woodwork
<input type="checkbox"/> Home Shop Machinist	<input type="checkbox"/> RC Modeler	<input type="checkbox"/> Woodworker West
<input type="checkbox"/> Journal of Light Cont.	<input type="checkbox"/> Rifle	<input type="checkbox"/> Woodworker's Journal
<input type="checkbox"/> Live Steam	<input type="checkbox"/> Shop Notes	<input type="checkbox"/> Other:
<input type="checkbox"/> Model Airplane News	<input type="checkbox"/> Shotgun News	
<input type="checkbox"/> Old House Journal	<input type="checkbox"/> Today's Homeowner	
<input type="checkbox"/> Popular Mechanics	<input type="checkbox"/> Wood	
  
3. What is your annual household income?
 

<input type="checkbox"/> \$20,000-\$29,000	<input type="checkbox"/> \$30,000-\$39,000	<input type="checkbox"/> \$40,000-\$49,000
<input type="checkbox"/> \$50,000-\$59,000	<input type="checkbox"/> \$60,000-\$69,000	<input type="checkbox"/> \$70,000+
  
4. What is your age group?
 

<input type="checkbox"/> 20-29	<input type="checkbox"/> 30-39	<input type="checkbox"/> 40-49
<input type="checkbox"/> 50-59	<input type="checkbox"/> 60-69	<input type="checkbox"/> 70+
  
5. How long have you been a woodworker/metalworker?
 

<input type="checkbox"/> 0-2 Years	<input type="checkbox"/> 2-8 Years	<input type="checkbox"/> 8-20 Years	<input type="checkbox"/> 20+ Years
------------------------------------	------------------------------------	-------------------------------------	------------------------------------
  
6. How many of your machines or tools are Grizzly?
 

<input type="checkbox"/> 0-2	<input type="checkbox"/> 3-5	<input type="checkbox"/> 6-9	<input type="checkbox"/> 10+
------------------------------	------------------------------	------------------------------	------------------------------
  
7. Do you think your machine represents a good value?  Yes  No
8. Would you recommend Grizzly Industrial to a friend?  Yes  No
9. Would you allow us to use your name as a reference for Grizzly customers in your area?  
**Note: We never use names more than 3 times.**  Yes  No

10. Comments: \_\_\_\_\_  
 \_\_\_\_\_  
 \_\_\_\_\_  
 \_\_\_\_\_

CUT ALONG DOTTED LINE

FOLD ALONG DOTTED LINE

---

---

---



Place  
Stamp  
Here



GRIZZLY INDUSTRIAL, INC.  
P.O. BOX 2069  
BELLINGHAM, WA 98227-2069



FOLD ALONG DOTTED LINE

Send a Grizzly Catalog to a friend:

Name _____
Street _____
City _____ State _____ Zip _____

TAPE ALONG EDGES--PLEASE DO NOT STAPLE



# *grizzly.com*<sup>®</sup>

**TOOL WEBSITE**

Buy Direct and Save with Grizzly<sup>®</sup> – Trusted, Proven and a Great Value!  
~Since 1983~

*Visit Our Website Today For  
Current Specials!*

**ORDER  
24 HOURS A DAY!  
1-800-523-4777**





## Free Manuals Download Website

<http://myh66.com>

<http://usermanuals.us>

<http://www.somanuals.com>

<http://www.4manuals.cc>

<http://www.manual-lib.com>

<http://www.404manual.com>

<http://www.luxmanual.com>

<http://aubethermostatmanual.com>

Golf course search by state

<http://golfingnear.com>

Email search by domain

<http://emailbydomain.com>

Auto manuals search

<http://auto.somanuals.com>

TV manuals search

<http://tv.somanuals.com>