

INSTRUCTIONS FOR C1367 FINGER JOINT BIT

Grizzly

Industrial, Inc.®

⚠ WARNING

- Failure to follow the SE guidelines will result in serious personal injury.
- ALWAYS WEAR ANSI APPROVED EYE AND EAR PROTECTION WHEN USING THIS BIT.
- The use of a router table is strongly recommended.
- Never feed lumber with the rotation of the bit.
- Follow the safety guidelines set forth by the manufacturer of the router and router table.

⚠ CAUTION

These router bits have sharp edges. Use care while removing the waxy protective coating. Never turn on the router with the protective coating still on the bit.

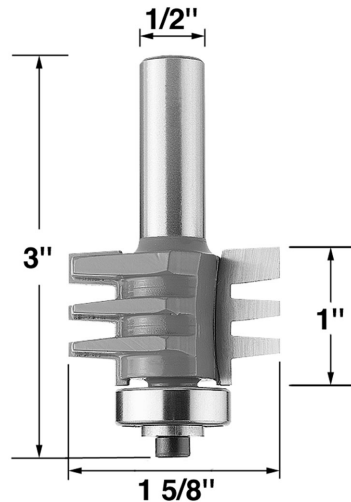

The Model C1367 Finger Joint Bit is designed specifically for creating strong, tight-fitting end joints in $\frac{3}{4}$ " thick stock. The bit features tough carbide cutting surfaces and a ball-bearing roller guide. This bit can be used in either a hand-held router or in a router table. For best results, we recommend using a router rated at a minimum of 1 horsepower, mounted in a router table to ensure maximum safety and efficiency.

The primary purpose of the Model C1367 router bit is to create extended lengths of $\frac{3}{4}$ " thick lumber by allowing the user to match and connect shorter lengths end-to-end. If handled carefully, clean, good-looking joints can be made which will stand up well to inspection.

⚠ WARNING

- Unplug shaper before installing or adjusting cutter.
- Keep all guards and anti-kick-back devices in place.
- Double check bit to insure it is tight and secure in spindle.
- Always inspect lumber and other wood materials for cracks, knots, or other imperfections that could cause lumber to kick or shatter while milling.

Make certain the ends of your stock have good clean cuts which are square to the the face and long edge. Lay out the pieces to be joined and match grain and color. It is unlikely that you will be able to match grains exactly, but a close match of color and grain width can be quite attractive. The care you take here will depend upon whether you plan to stain or paint the finished product. Once you have paired the butt ends, mark each piece on the faces which will be on the same side.

When using bit on a router table:

Set the router bit height so that the router bit is centered to the wood (See drawing). The lower portion of the cutter should protrude from the table surface exactly the same amount as the uppermost portion of the bit. The use of a

fence(s) will be required. Set the fence face to the bearing on the cutting side of the bit. Before cutting the workpiece, make some trial cuts using scrap lumber. It must be the same thickness as your workpiece. Make cuts on two boards and assemble these pieces to determine if the height of the bit needs correcting. Adjust height and test cut until the desired accuracy has been achieved.

**THE WORKPIECE
SHOULD CONTACT
THESE SURFACES
EQUALLY**

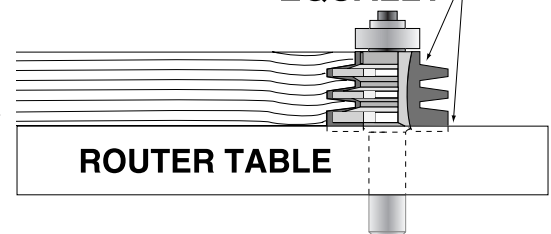

Helpful hint: For each paired joint, make your first cut with the marked face up. To make the matching cut on your second piece of lumber, turn it over so the marked face is down. When you have completed your second

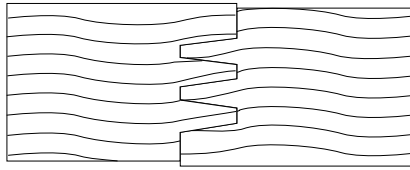

Mis-matched

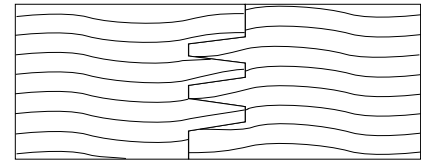

Matched

cut, turn the second board back over and check the fit of the joint. The two halves of the joint should fit tightly with no spaces in the fingers, and with the two faces perfectly even.

If there is any mismatch, first make certain that the router height adjustment is locked securely – any variation between cuts will result in a mis-matched joint. Also make sure when you move the piece through the cutter that the face stays firmly seated on the router table. Check to see that the guide bearing has a good clean surface along the edge to follow. Finally, if mismatch still persists check the wood to be sure the edges and face are square.

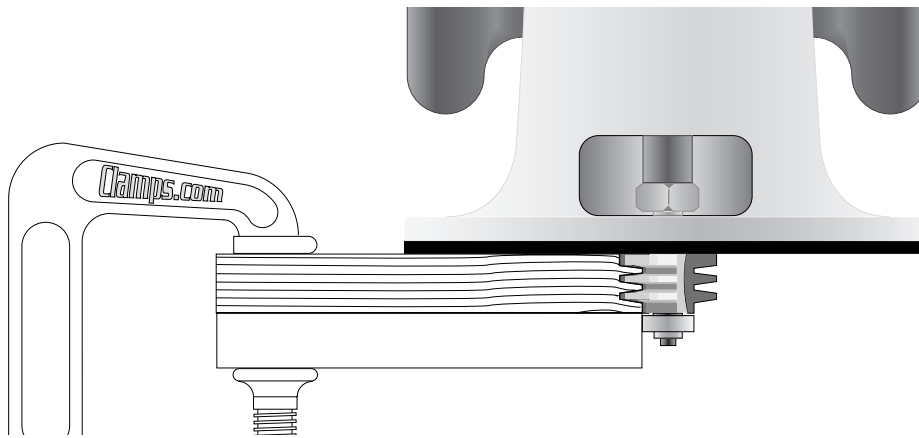

When using bit on a router without a table:

A bearing is provided with the DC1367 router bit that allows it to be used without a router table. Use 2 clamps and secure a straight board with a square edge onto the end of the workpiece. This will be used as a guide. Use a square to make sure that this guide board is square to the workpiece. Make sure the workpiece is flush to or protrudes from, the edge of the guide board a small amount- less than 1/8".

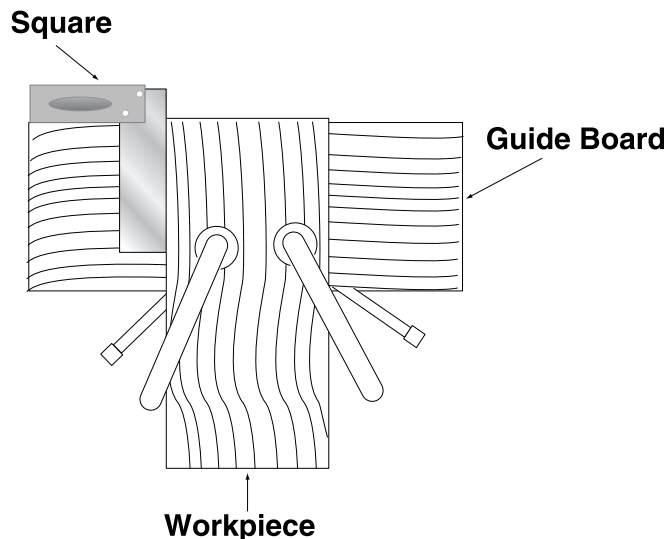

Free Manuals Download Website

<http://myh66.com>

<http://usermanuals.us>

<http://www.somanuals.com>

<http://www.4manuals.cc>

<http://www.manual-lib.com>

<http://www.404manual.com>

<http://www.luxmanual.com>

<http://aubethermostatmanual.com>

Golf course search by state

<http://golfingnear.com>

Email search by domain

<http://emailbydomain.com>

Auto manuals search

<http://auto.somanuals.com>

TV manuals search

<http://tv.somanuals.com>