

Grizzly **Industrial, Inc.**®

MODEL G0766 **22" X 42" VARIABLE-SPEED** **WOOD LATHE** **OWNER'S MANUAL** *(For models manufactured since 07/15)*



COPYRIGHT © MARCH, 2015 BY GRIZZLY INDUSTRIAL, INC., REVISED OCTOBER, 2015 (MN)
**WARNING: NO PORTION OF THIS MANUAL MAY BE REPRODUCED IN ANY SHAPE
OR FORM WITHOUT THE WRITTEN APPROVAL OF GRIZZLY INDUSTRIAL, INC.**
#MN17299 PRINTED IN CHINA

V2.09.15

 **WARNING!**

This manual provides critical safety instructions on the proper setup, operation, maintenance, and service of this machine/tool. Save this document, refer to it often, and use it to instruct other operators.

Failure to read, understand and follow the instructions in this manual may result in fire or serious personal injury—including amputation, electrocution, or death.

The owner of this machine/tool is solely responsible for its safe use. This responsibility includes but is not limited to proper installation in a safe environment, personnel training and usage authorization, proper inspection and maintenance, manual availability and comprehension, application of safety devices, cutting/sanding/grinding tool integrity, and the usage of personal protective equipment.

The manufacturer will not be held liable for injury or property damage from negligence, improper training, machine modifications or misuse.

 **WARNING!**

Some dust created by power sanding, sawing, grinding, drilling, and other construction activities contains chemicals known to the State of California to cause cancer, birth defects or other reproductive harm. Some examples of these chemicals are:

- **Lead from lead-based paints.**
- **Crystalline silica from bricks, cement and other masonry products.**
- **Arsenic and chromium from chemically-treated lumber.**

Your risk from these exposures varies, depending on how often you do this type of work. To reduce your exposure to these chemicals: Work in a well ventilated area, and work with approved safety equipment, such as those dust masks that are specially designed to filter out microscopic particles.

Table of Contents

INTRODUCTION	2	SECTION 5: ACCESSORIES	34
Contact Info.....	2	SECTION 6: MAINTENANCE.....	37
Manual Accuracy	2	Schedule	37
Identification.....	3	Cleaning & Protecting	37
Controls & Components.....	4	Lubrication	37
Glossary Of Terms.....	5	SECTION 7: SERVICE	38
SECTION 1: SAFETY	8	Troubleshooting	38
Safety Instructions for Machinery	8	Changing Belt	40
Additional Safety for Wood Lathes	10	SECTION 8: WIRING.....	41
SECTION 2: POWER SUPPLY	11	Wiring Safety Instructions	41
SECTION 3: SETUP	13	Wiring Diagram	42
Needed for Setup.....	13	Wiring Components	43
Unpacking	13	SECTION 9: PARTS	44
Inventory	14	Main Breakdown	44
Cleanup.....	15	Labels	46
Site Considerations.....	16	WARRANTY & RETURNS	49
Anchoring to Floor	17		
Assembly	17		
Test Run	19		
SECTION 4: OPERATIONS	20		
Operation Overview	20		
Workpiece Inspection.....	21		
Adjusting Headstock	21		
Adjusting Tailstock.....	22		
Adjusting Tool Rest.....	22		
Installing/Removing Headstock Center.....	24		
Installing/Removing Tailstock Center	25		
Installing Faceplate.....	26		
Changing Speed Ranges.....	26		
Indexing	28		
Spindle Turning.....	28		
Faceplate Turning.....	30		
Outboard Turning.....	31		
Sanding/Finishing	32		
Selecting Turning Tools.....	33		

INTRODUCTION

Contact Info

We stand behind our machines! If you have questions or need help, contact us with the information below. Before contacting, make sure you get the **serial number** and **manufacture date** from the machine ID label. This will help us help you faster.

Grizzly Technical Support
1815 W. Battlefield
Springfield, MO 65807
Phone: (570) 546-9663
Email: techsupport@grizzly.com

We want your feedback on this manual. What did you like about it? Where could it be improved? Please take a few minutes to give us feedback.

Grizzly Documentation Manager
P.O. Box 2069
Bellingham, WA 98227-2069
Email: manuals@grizzly.com

Manual Accuracy

We are proud to provide a high-quality owner's manual with your new machine!

We made every effort to be exact with the instructions, specifications, drawings, and photographs in this manual. Sometimes we make mistakes, but our policy of continuous improvement also means that **sometimes the machine you receive is slightly different than shown in the manual.**

If you find this to be the case, and the difference between the manual and machine leaves you confused or unsure about something, check our website for an updated version. We post current manuals and manual updates for free on our website at **www.grizzly.com**.

Alternatively, you can call our Technical Support for help. Before calling, make sure you write down the **Manufacture Date** and **Serial Number** from the machine ID label (see below). This information is required for us to provide proper tech support, and it helps us determine if updated documentation is available for your machine.

		MODEL GXXXX MACHINE NAME	
SPECIFICATIONS		▲ WARNING!	
Motor:	To reduce risk of serious injury when using this machine:		
Specification:	Read the manual before operation.		
Specification:	Wear safety glasses and respirator.		
Specification:	Ensure safety glasses/respirator are properly adjusted/setup and		
Specification:	power is connected to grounded circuit before starting.		
Weight:	4. Make sure the motor has stopped and disconnect power before adjustments, maintenance, or service.		
	5. DO NOT expose to rain or dampness.		
	6. DO NOT modify this machine in any way.		
	7.		
	8.		
	9. Do not drink or use alcohol while operating the machine.		
	10. Maintain machine carefully to prevent accidents.		

Manufactured for Grizzly in Taiwan



Identification

Become familiar with the names and locations of the controls and features shown below to better understand the instructions in this manual.

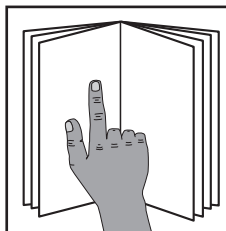
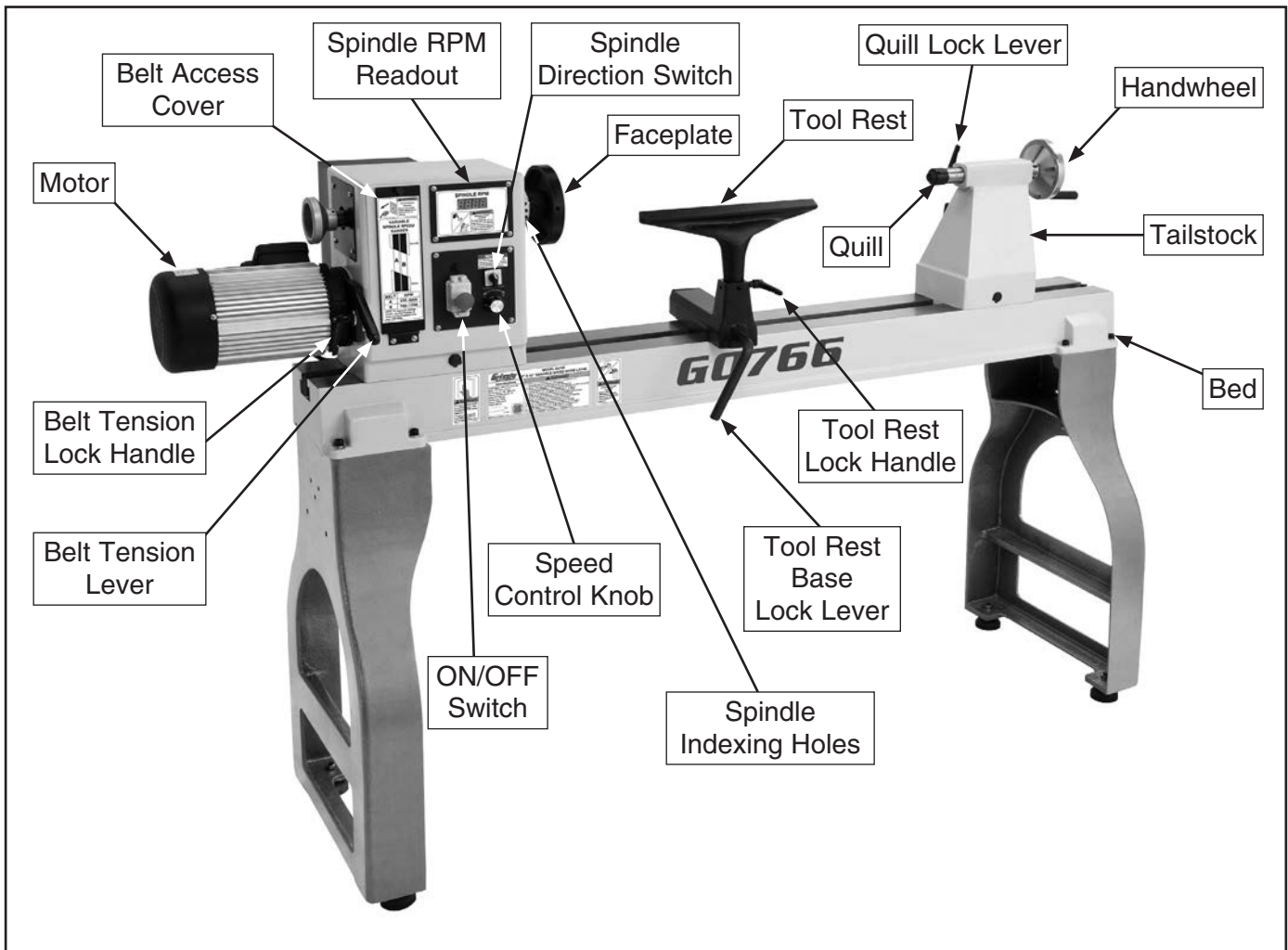

!WARNING

To reduce your risk of serious injury, read this entire manual **BEFORE** using machine.



Controls & Components

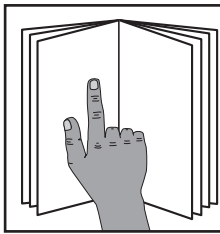

⚠️ WARNING

To reduce your risk of serious injury, read this entire manual **BEFORE** using machine.

Refer to **Figures 1–3** and the following descriptions to become familiar with the basic controls of this machine.

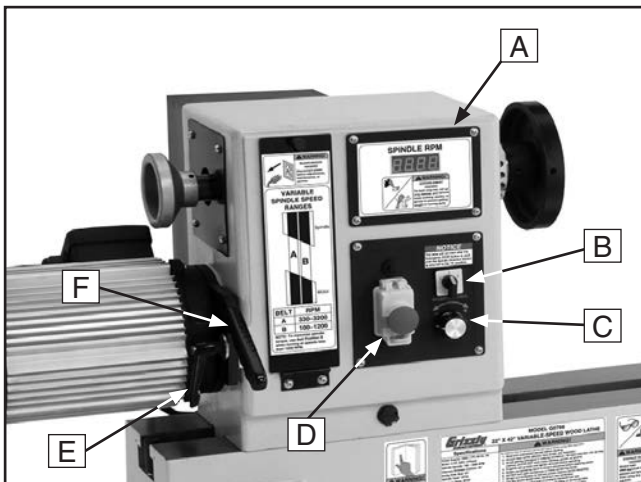

Figure 1. Headstock controls.

- A. Spindle RPM Readout:** Indicates spindle speed in rotations per minute (RPM).
- B. Spindle Direction Switch:** Toggles spindle direction between clockwise and counter-clockwise.
- C. Speed Control Knob:** Adjusts spindle speed from low to high within range governed by pulley belt position.
- D. ON/OFF Switch w/Emergency Stop Button:** Turns lathe ON and OFF.
- E. Belt Tension Lock Handle:** Locks belt tension lever in place.
- F. Belt Tension Lever:** Increases and decreases amount of tension on belt.

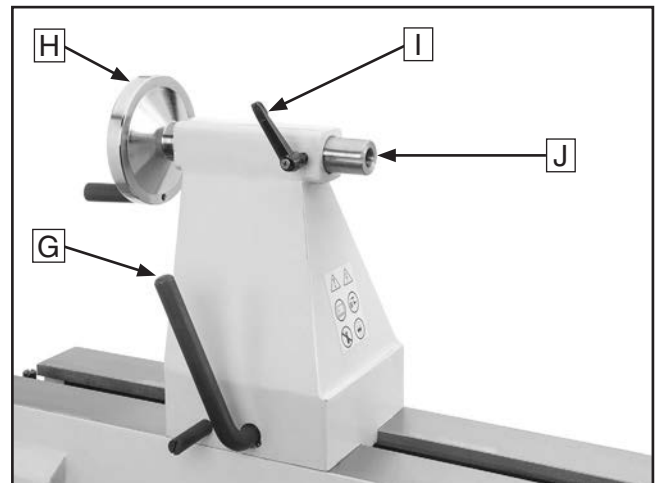

Figure 2. Tailstock controls.

- G. Tailstock Lock Lever:** Secures tailstock in position along bed.
- H. Tailstock Handwheel:** Moves quill toward or away from spindle.
- I. Quill Lock Handle:** Secures quill in position.
- J. Quill:** Holds centers or tooling. Can be moved toward and away from spindle.

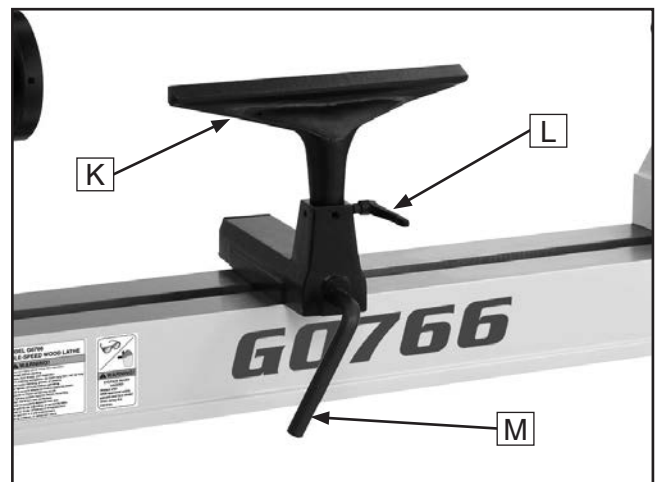

Figure 3. Tool rest controls.

- K. Tool Rest:** Provides stable platform for cutting tools.
- L. Tool Rest Lock Handle:** Secures tool rest in position.
- M. Tool Rest Base Lock Lever:** Secures tool rest base in position.



Glossary Of Terms

The following is a list of common definitions, terms and phrases used throughout this manual as they relate to this wood lathe and turning in general. Become familiar with these terms for assembling, adjusting or operating this machine. Your safety is **VERY** important to us at Grizzly!

Bed: The long, rail-like metal base to which the tailstock, tool base, and headstock are attached.

Chuck: A mechanical device that attaches to the spindle and holds the workpiece.

Faceplate: The metal disc that threads onto the headstock spindle.

Faceplate Turning: Turning situation in which the grain of the turning stock is at right angles to the lathe bed axis.

Backing Block: A sacrificial piece of wood glued to the base of the workpiece and screwed to the faceplate. Often used to prevent mounting marks from appearing on the completed workpiece.

Headstock: The cast metal box to which the motor is attached and contains the spindle, bearings, belts, and electrical components for operating the lathe.

Index Head: The mechanism that allows the headstock spindle to be locked at specific intervals for layout or other auxiliary tasks.

Offset Turning: A turning situation where the center of the workpiece is offset at various stages of the work to produce different shapes.

Outboard Turning: Turning of workpiece with the headstock situated at the far end of the lathe so the work done is not over the bed of the lathe.

Roughing Out: Taking stock from square billet to round blank.

Spindle: This term has two meanings. First, it refers to the threaded shaft in the headstock to which the faceplate is attached. Second, it refers to any work that is spindle-turned.

Spindle-Turning: Work performed where the grain and length of the workpiece are parallel to the axis of the bed.

Swing: The capacity of the lathe, measured by doubling the distance from the bed to the spindle center.

Tailstock: The metal component at the opposite end of the bed from the headstock containing a quill and live or dead centers. It maintains pressure on the spindle-turned workpiece.

Tool Base: The movable metal fixture attached to the bed upon which the tool rest is fixed.

Tool Rest: The adjustable metal arm upon which the tool rests during a turning operation.

Way: One of the metal rails that make up the bed of the lathe.





MACHINE DATA SHEET

Customer Service #: (570) 546-9663 · To Order Call: (800) 523-4777 · Fax #: (800) 438-5901

MODEL G0766 22" X 42" VARIABLE-SPEED WOOD LATHE

Product Dimensions:

Weight..... 496 lbs.
 Width (side-to-side) x Depth (front-to-back) x Height..... 81 x 23 x 49-1/2 in.
 Footprint (Length x Width)..... 65-1/2 x 20 in.

Shipping Dimensions:

Type..... Wood Box
 Content..... Machine
 Weight..... 662 lbs.
 Length x Width x Height..... 69 x 24 x 25 in.

Electrical:

Power Requirement..... 220V, Single-Phase, 60 Hz
 Full-Load Current Rating..... 4A
 Minimum Circuit Size..... 15A
 Connection Type..... Cord & Plug
 Power Cord Included..... Yes
 Power Cord Length..... 6 ft.
 Power Cord Gauge..... 14 AWG
 Plug Included..... Yes
 Included Plug Type..... NEMA 6-15
 Switch Type..... ON/OFF Push Button Switch w/Safety Cover
 Inverter Type..... Delta VFD-M
 Inverter Size..... 3 HP

Motors:

Main

Type..... TEFC Induction
 Horsepower..... 3 HP
 Phase..... 3-Phase
 Amps..... 4A
 Speed..... 1725 RPM
 Power Transfer Belt Drive
 Bearings..... Sealed & Permanently Lubricated

Main Specifications:

Operation Information

Swing Over Bed..... 22 in.
 Distance Between Centers..... 42 in.
 Swing Over Tool Rest..... 16 in.
 Swing Over Tool Rest Base..... 18 in.
 No of Spindle Speeds..... Variable
 Spindle Speed Range..... 100 – 3200 RPM
 Floor to Center Height..... 46-1/4 in.
 Headstock Rotation..... 180 deg.



Spindle Information

Spindle Taper.....	MT#2
Spindle Thread Size.....	1-1/4" x 8 TPI
Spindle Thread Direction.....	Right Hand
Spindle Bore.....	0.393 in.
Type of Included Spindle Center.....	Spur
Indexed Spindle Increments.....	10 deg.
No of Indexes.....	36

Tool Rest Information

Tool Rest Width.....	14 in.
Tool Rest Post Diameter.....	25 mm
Tool Rest Post Length.....	2-1/4 in.
Tool Rest Base Height.....	2 in.

Tailstock Information

Tailstock Taper.....	MT#2
Type of Included Tailstock Center.....	Live

Construction

Bed.....	Cast Iron
Frame.....	Cast Iron
Stand.....	Cast Iron
Base.....	Cast Iron
Headstock.....	Cast Iron
Tailstock.....	Cast Iron
Paint Type/Finish.....	Enamel

Other Related Information

Bed Width.....	10 in.
Faceplate Size.....	6 in.

Other Specifications:

Country of Origin	China
Warranty	1 Year
Approximate Assembly & Setup Time	1 Hour
Serial Number Location	ID Label
ISO 9001 Factory	Yes
Certified by a Nationally Recognized Testing Laboratory (NRTL)	No

Features:

Low speed range of 100–1200 RPM and high speed range of 330–3200 RPM
 Electronic variable-speed control with digital spindle-speed indicator
 Headstock rotates 180° and positions anywhere along the bed
 Single-phase frequency drive provides three-phase variable-speed control without three-phase power
 10° spindle indexing
 Tailstock, headstock, and tool rest support have lever-action cam locks for quick positioning
 Forward/reverse spindle control
 4-1/4" tailstock barrel travel

Accessories Included:

Spur center
 Cupped live center
 Knock-out tool
 Tool rest
 Faceplate 6"
 Indexing pin



SECTION 1: SAFETY

For Your Own Safety, Read Instruction Manual Before Operating This Machine

The purpose of safety symbols is to attract your attention to possible hazardous conditions. This manual uses a series of symbols and signal words intended to convey the level of importance of the safety messages. The progression of symbols is described below. Remember that safety messages by themselves do not eliminate danger and are not a substitute for proper accident prevention measures. Always use common sense and good judgment.

 **DANGER** Indicates an imminently hazardous situation which, if not avoided, **WILL** result in death or serious injury.

 **WARNING** Indicates a potentially hazardous situation which, if not avoided, **COULD** result in death or serious injury.

 **CAUTION** Indicates a potentially hazardous situation which, if not avoided, **MAY** result in minor or moderate injury. It may also be used to alert against unsafe practices.

NOTICE This symbol is used to alert the user to useful information about proper operation of the machine.

Safety Instructions for Machinery

WARNING

OWNER'S MANUAL. Read and understand this owner's manual **BEFORE** using machine.

TRAINED OPERATORS ONLY. Untrained operators have a higher risk of being hurt or killed. Only allow trained/supervised people to use this machine. When machine is not being used, disconnect power, remove switch keys, or lock-out machine to prevent unauthorized use—especially around children. Make workshop kid proof!

DANGEROUS ENVIRONMENTS. Do not use machinery in areas that are wet, cluttered, or have poor lighting. Operating machinery in these areas greatly increases the risk of accidents and injury.

MENTAL ALERTNESS REQUIRED. Full mental alertness is required for safe operation of machinery. Never operate under the influence of drugs or alcohol, when tired, or when distracted.

ELECTRICAL EQUIPMENT INJURY RISKS. You can be shocked, burned, or killed by touching live electrical components or improperly grounded machinery. To reduce this risk, only allow qualified service personnel to do electrical installation or repair work, and always disconnect power before accessing or exposing electrical equipment.

DISCONNECT POWER FIRST. Always disconnect machine from power supply **BEFORE** making adjustments, changing tooling, or servicing machine. This prevents an injury risk from unintended startup or contact with live electrical components.

EYE PROTECTION. Always wear ANSI-approved safety glasses or a face shield when operating or observing machinery to reduce the risk of eye injury or blindness from flying particles. Everyday eyeglasses are **NOT** approved safety glasses.



WARNING

WEARING PROPER APPAREL. Do not wear clothing, apparel or jewelry that can become entangled in moving parts. Always tie back or cover long hair. Wear non-slip footwear to reduce risk of slipping and losing control or accidentally contacting cutting tool or moving parts.

HAZARDOUS DUST. Dust created by machinery operations may cause cancer, birth defects, or long-term respiratory damage. Be aware of dust hazards associated with each workpiece material. Always wear a NIOSH-approved respirator to reduce your risk.

HEARING PROTECTION. Always wear hearing protection when operating or observing loud machinery. Extended exposure to this noise without hearing protection can cause permanent hearing loss.

REMOVE ADJUSTING TOOLS. Tools left on machinery can become dangerous projectiles upon startup. Never leave chuck keys, wrenches, or any other tools on machine. Always verify removal before starting!

USE CORRECT TOOL FOR THE JOB. Only use this tool for its intended purpose—do not force it or an attachment to do a job for which it was not designed. Never make unapproved modifications—modifying tool or using it differently than intended may result in malfunction or mechanical failure that can lead to personal injury or death!

AWKWARD POSITIONS. Keep proper footing and balance at all times when operating machine. Do not overreach! Avoid awkward hand positions that make workpiece control difficult or increase the risk of accidental injury.

CHILDREN & BYSTANDERS. Keep children and bystanders at a safe distance from the work area. Stop using machine if they become a distraction.

GUARDS & COVERS. Guards and covers reduce accidental contact with moving parts or flying debris. Make sure they are properly installed, undamaged, and working correctly **BEFORE** operating machine.

FORCING MACHINERY. Do not force machine. It will do the job safer and better at the rate for which it was designed.

NEVER STAND ON MACHINE. Serious injury may occur if machine is tipped or if the cutting tool is unintentionally contacted.

STABLE MACHINE. Unexpected movement during operation greatly increases risk of injury or loss of control. Before starting, verify machine is stable and mobile base (if used) is locked.

USE RECOMMENDED ACCESSORIES. Consult this owner's manual or the manufacturer for recommended accessories. Using improper accessories will increase the risk of serious injury.

UNATTENDED OPERATION. To reduce the risk of accidental injury, turn machine **OFF** and ensure all moving parts completely stop before walking away. Never leave machine running while unattended.

MAINTAIN WITH CARE. Follow all maintenance instructions and lubrication schedules to keep machine in good working condition. A machine that is improperly maintained could malfunction, leading to serious personal injury or death.

DAMAGED PARTS. Regularly inspect machine for damaged, loose, or mis-adjusted parts—or any condition that could affect safe operation. Immediately repair/replace **BEFORE** operating machine. For your own safety, **DO NOT** operate machine with damaged parts!

MAINTAIN POWER CORDS. When disconnecting cord-connected machines from power, grab and pull the plug—**NOT** the cord. Pulling the cord may damage the wires inside. Do not handle cord/plug with wet hands. Avoid cord damage by keeping it away from heated surfaces, high traffic areas, harsh chemicals, and wet/damp locations.

EXPERIENCING DIFFICULTIES. If at any time you experience difficulties performing the intended operation, stop using the machine! Contact our Technical Support at (570) 546-9663.



Additional Safety for Wood Lathes

WARNING

Serious injury or death can occur from getting entangled in, crushed between, or struck by rotating parts on a lathe! Rotating workpieces can come loose and strike operator or bystanders with deadly force if they are improperly secured, rotated too fast, or are not strong enough for the rotational forces required for turning. Improper tool setup or usage can cause tool kickback or grabbing, resulting in impact injury or entanglement. To reduce the risk of operator (or bystander) injury or death, anyone operating this machine **MUST** completely heed the hazards and warnings below.

CHECK WORKPIECE INTEGRITY. Verify each workpiece is free of knots, splits, nails, or foreign material to ensure it can safely rotate on spindle without breaking apart or causing tool kickback.

PROPERLY PREPARE WORKPIECE. Before mounting, cut off waste portions to balance workpiece for safe rotation and remove large edges that can catch on tooling.

SECURE LOCKS. Verify tool rest, headstock, and tailstock are secure before turning lathe **ON**.

SECURE WORKPIECE. Use proven setup techniques and always verify workpiece is well-secured before starting lathe. Only use high-quality fasteners with non-tapered heads for faceplate attachment.

ADJUST TOOL SUPPORT. An improperly supported tool may be grabbed or ejected. Adjust tool rest approximately $\frac{1}{4}$ " away from workpiece and $\frac{1}{8}$ " above workpiece center line to provide proper support for turning tool. Firmly hold turning tool with both hands against tool rest.

TEST NEW SETUPS. Test each new setup by starting spindle rotation at lowest speed and standing to side of lathe until workpiece reaches full speed and you can verify safe rotation.

REMOVE ADJUSTMENT TOOLS. Remove all chuck keys, wrenches, and adjustment tools before turning lathe **ON**. These items can become deadly projectiles when spindle is started.

CHECK CLEARANCES. Before starting spindle, verify workpiece has adequate clearance by hand-rotating it through its entire range of motion.

WEAR PROPER PPE. Always wear a face shield and safety glasses when operating lathe. Do not wear gloves, necktie or loose clothing. Keep long hair away from rotating spindle.

USE CORRECT SPEEDS. Select correct spindle speed for workpiece size, type, shape, and condition. Use low speeds when roughing or when turning large, long, or non-concentric workpieces. Allow spindle to reach full speed before turning.

AVOID TOOL KICKBACK. This occurs when turning tool is grabbed or ejected from workpiece with great force. Commonly caused by poor workpiece selection/preparation, improper tool usage, or improper machine setup or tool rest adjustment.

SAFELY PERFORM ROUGHING. Use correct tool. Take light cuts, use low speeds, and firmly support tool with both hands.

USE SHARP TOOLS. Sharp tools cut with less resistance than dull tools. Using dull tools increases the risk of tool kickback or grabbing.

SAFELY STOPPING ROTATION. Always allow rotating workpiece to stop on its own. Never put hands or another object on workpiece to stop it.

SAFELY MEASURE WORKPIECE. Only measure workpiece after it has stopped. Trying to measure a spinning workpiece increases entanglement risk.

SANDING/POLISHING. To reduce entanglement risk, remove tool rest before sanding. Never completely wrap sandpaper around workpiece.



SECTION 2: POWER SUPPLY

Availability

Before installing the machine, consider the availability and proximity of the required power supply circuit. If an existing circuit does not meet the requirements for this machine, a new circuit must be installed. To minimize the risk of electrocution, fire, or equipment damage, installation work and electrical wiring must be done by an electrician or qualified service personnel in accordance with all applicable codes and standards.

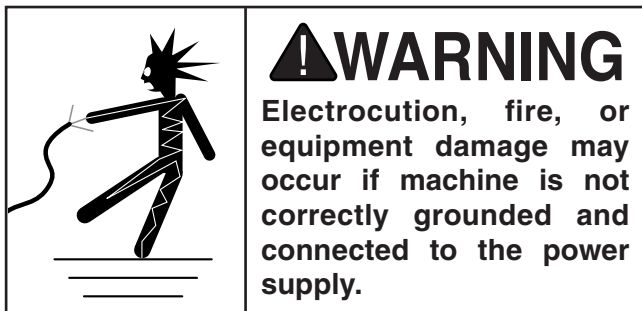

Full-Load Current Rating

The full-load current rating is the amperage a machine draws at 100% of the rated output power. On machines with multiple motors, this is the amperage drawn by the largest motor or sum of all motors and electrical devices that might operate at one time during normal operations.

Full-Load Current Rating at 220V 4 Amps

The full-load current is not the maximum amount of amps that the machine will draw. If the machine is overloaded, it will draw additional amps beyond the full-load rating.

If the machine is overloaded for a sufficient length of time, damage, overheating, or fire may result—especially if connected to an undersized circuit. To reduce the risk of these hazards, avoid overloading the machine during operation and make sure it is connected to a power supply circuit that meets the specified circuit requirements.

Circuit Information

A power supply circuit includes all electrical equipment between the breaker box or fuse panel in the building and the machine. The power supply circuit used for this machine must be sized to safely handle the full-load current drawn from the machine for an extended period of time. (If this machine is connected to a circuit protected by fuses, use a time delay fuse marked D.)

! CAUTION
For your own safety and protection of property, consult an electrician if you are unsure about wiring practices or electrical codes in your area.

Note: *Circuit requirements in this manual apply to a dedicated circuit—where only one machine will be running on the circuit at a time. If machine will be connected to a shared circuit where multiple machines may be running at the same time, consult an electrician or qualified service personnel to ensure circuit is properly sized for safe operation.*

Circuit Requirements

This machine is prewired to operate on a power supply circuit that has a verified ground and meets the following requirements:

Nominal Voltage 208V, 220V, 230V, 240V
Cycle 60 Hz
Phase Single-Phase
Power Supply Circuit 15 Amps
Plug/Receptacle NEMA 6-15



Grounding Requirements

This machine **MUST** be grounded. In the event of certain malfunctions or breakdowns, grounding reduces the risk of electric shock by providing a path of least resistance for electric current.

This machine is equipped with a power cord that has an equipment-grounding wire and a grounding plug. Only insert plug into a matching receptacle (outlet) that is properly installed and grounded in accordance with all local codes and ordinances. **DO NOT** modify the provided plug!

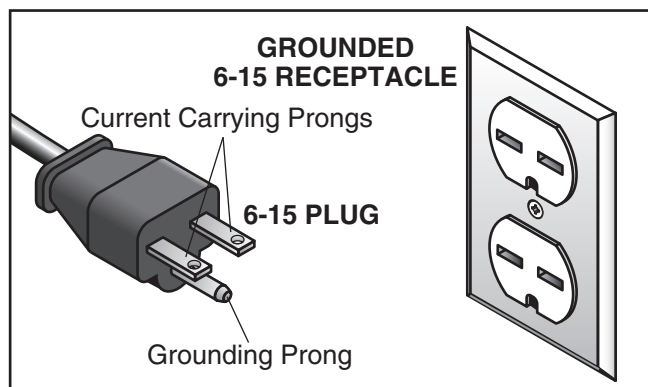
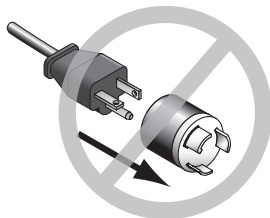

Figure 4. Typical 6-15 plug and receptacle.

CAUTION



No adapter should be used with plug. If plug does not fit available receptacle, or if machine must be reconnected for use on a different type of circuit, reconnection must be performed by an electrician or qualified service personnel, and it must comply with all local codes and ordinances.

WARNING

Serious injury could occur if you connect machine to power before completing setup process. DO NOT connect to power until instructed later in this manual.

Improper connection of the equipment-grounding wire can result in a risk of electric shock. The wire with green insulation (with or without yellow stripes) is the equipment-grounding wire. If repair or replacement of the power cord or plug is necessary, do not connect the equipment-grounding wire to a live (current carrying) terminal.

Check with a qualified electrician or service personnel if you do not understand these grounding requirements, or if you are in doubt about whether the tool is properly grounded. If you ever notice that a cord or plug is damaged or worn, disconnect it from power, and immediately replace it with a new one.

Extension Cords

We do not recommend using an extension cord with this machine. If you must use an extension cord, only use it if absolutely necessary and only on a temporary basis.

Extension cords cause voltage drop, which can damage electrical components and shorten motor life. Voltage drop increases as the extension cord size gets longer and the gauge size gets smaller (higher gauge numbers indicate smaller sizes).

Any extension cord used with this machine must be in good condition and contain a ground wire and matching plug/receptacle. Additionally, it must meet the following size requirements:

Minimum Gauge Size 14 AWG
Maximum Length (Shorter is Better).....50 ft.



SECTION 3: SETUP

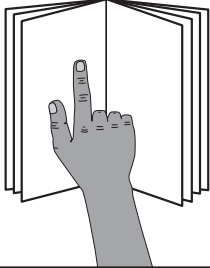

!WARNING
 This machine presents serious injury hazards to untrained users. Read through this entire manual to become familiar with the controls and operations before starting the machine!



!WARNING
 Wear safety glasses during the entire setup process!

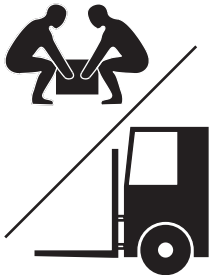

!WARNING
HEAVY LIFT!
 Straining or crushing injury may occur from improperly lifting machine or some of its parts. To reduce this risk, get help from other people and use a forklift (or other lifting equipment) rated for weight of this machine.

Needed for Setup

The following are needed to complete the setup process:

Description	Qty
• Level	1
• Safety Glasses (for each person).....	1
• Solvent/Cleaner	1
• Shop Rags.....	As Needed
• Additional People	As Needed

Unpacking

Your machine was carefully packaged for safe transportation. Remove the packaging materials from around your machine and inspect it. If you discover any damage, *please call us immediately at (570) 546-9663 for advice.*

Save the containers and all packing materials for possible inspection by the carrier or its agent. *Otherwise, filing a freight claim can be difficult.*

When you are completely satisfied with the condition of your shipment, inventory the contents.



!WARNING
SUFFOCATION HAZARD!
 Keep children and pets away from plastic bags or packing materials shipped with this machine. Discard immediately.



Inventory

The following is a list of items shipped with your machine. Before beginning setup, lay these items out and inventory them.

If any non-proprietary parts are missing (e.g. a nut or a washer), we will gladly replace them; or for the sake of expediency, replacements can be obtained at your local hardware store.

B.	Stand Legs	2
C.	Live Center MT#2	1
D.	Spur Center MT#2	1
E.	Indexing Pin.....	1
F.	Tool Rest	1
G.	Hex Wrenches 3, 4, 6, 8mm.....	1 Ea
H.	Machine Feet.....	4
I.	Knockout Tool.....	1
J.	Hardware (not shown)	
	—Cap Screws M8-1.25 x 35	10
	—Lock Washers 8mm.....	10
	—Hex Nuts M8-1.25	2

NOTICE

If you cannot find an item on this list, carefully check around/inside the machine and packaging materials. Often, these items get lost in packaging materials while unpacking or they are pre-installed at the factory.

After all the parts have been removed from the shipping containers, you should have the following items:

Inventory: (Figures 5–7)	Qty
A. Lathe Assembly	
—Headstock (mounted)	1
—Tool Rest Base (mounted)	1
—Tailstock (mounted).....	1
—Faceplate 6" (installed)	1

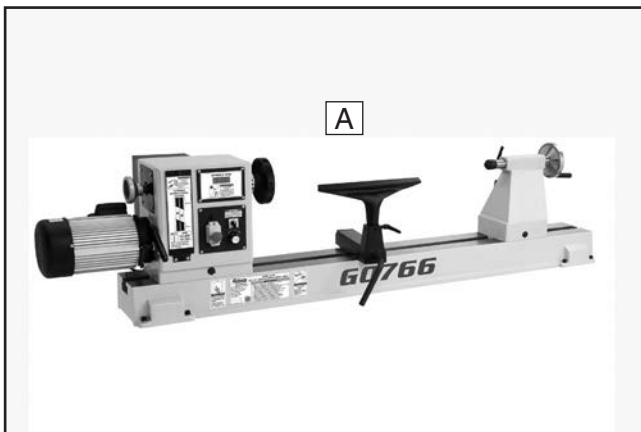

Figure 5. Lathe assembly.

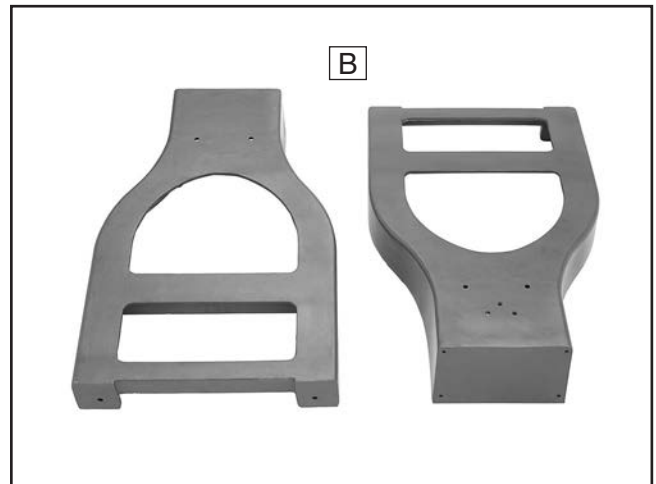

Figure 6. Stand legs.

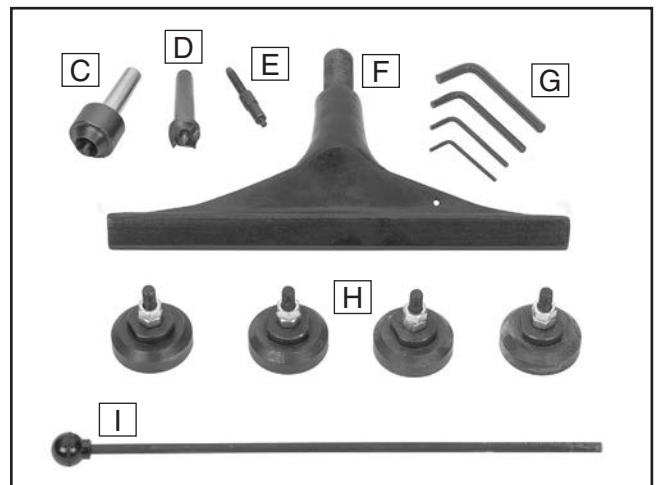

Figure 7. Loose inventory components.



Cleanup

The unpainted surfaces of your machine are coated with a heavy-duty rust preventative that prevents corrosion during shipment and storage. This rust preventative works extremely well, but it will take a little time to clean.

Be patient and do a thorough job cleaning your machine. The time you spend doing this now will give you a better appreciation for the proper care of your machine's unpainted surfaces.

There are many ways to remove this rust preventative, but the following steps work well in a wide variety of situations. Always follow the manufacturer's instructions with any cleaning product you use and make sure you work in a well-ventilated area to minimize exposure to toxic fumes.

Before cleaning, gather the following:

- Disposable rags
- Cleaner/degreaser (WD-40 works well)
- Safety glasses & disposable gloves
- Plastic paint scraper (optional)

Basic steps for removing rust preventative:

1. Put on safety glasses.
2. Coat the rust preventative with a liberal amount of cleaner/degreaser, then let it soak for 5–10 minutes.
3. Wipe off the surfaces. If your cleaner/degreaser is effective, the rust preventative will wipe off easily. If you have a plastic paint scraper, scrape off as much as you can first, then wipe off the rest with the rag.
4. Repeat **Steps 2–3** as necessary until clean, then coat all unpainted surfaces with a quality metal protectant to prevent rust.

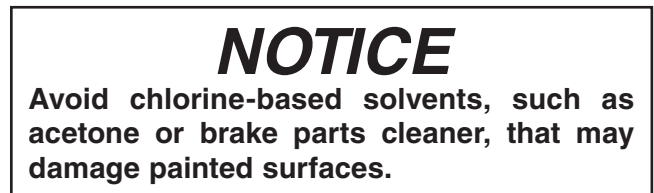
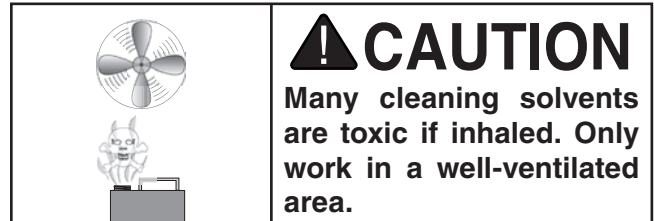
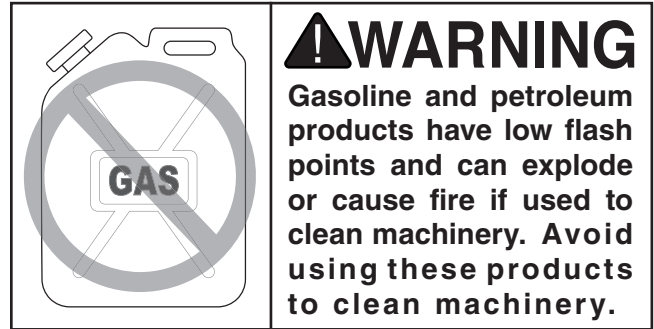

T23692—Orange Power Degreaser

A great product for removing the waxy shipping grease from your machine during clean up.



Figure 8. T23692 Orange Power Degreaser.



Site Considerations

Weight Load

Refer to the **Machine Data Sheet** for the weight of your machine. Make sure that the surface upon which the machine is placed will bear the weight of the machine, additional equipment that may be installed on the machine, and the heaviest workpiece that will be used. Additionally, consider the weight of the operator and any dynamic loading that may occur when operating the machine.

Space Allocation

Consider the largest size of workpiece that will be processed through this machine and provide enough space around the machine for adequate operator material handling or the installation of auxiliary equipment. With permanent installations, leave enough space around the machine to open or remove doors/covers as required by the maintenance and service described in this manual. **See below for required space allocation.**

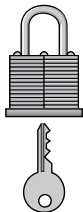
	<p>CAUTION</p> <p>Children or untrained people may be seriously injured by this machine. Only install in an access restricted location.</p>
---	--

Physical Environment

The physical environment where the machine is operated is important for safe operation and longevity of machine components. For best results, operate this machine in a dry environment that is free from excessive moisture, hazardous chemicals, airborne abrasives, or extreme conditions. Extreme conditions for this type of machinery are generally those where the ambient temperature range exceeds 41°–104°F; the relative humidity range exceeds 20%–95% (non-condensing); or the environment is subject to vibration, shocks, or bumps.

Electrical Installation

Place this machine near an existing power source. Make sure all power cords are protected from traffic, material handling, moisture, chemicals, or other hazards. Make sure to leave enough space around machine to disconnect power supply or apply a lockout/tagout device, if required.

Lighting

Lighting around the machine must be adequate enough that operations can be performed safely. Shadows, glare, or strobe effects that may distract or impede the operator must be eliminated.

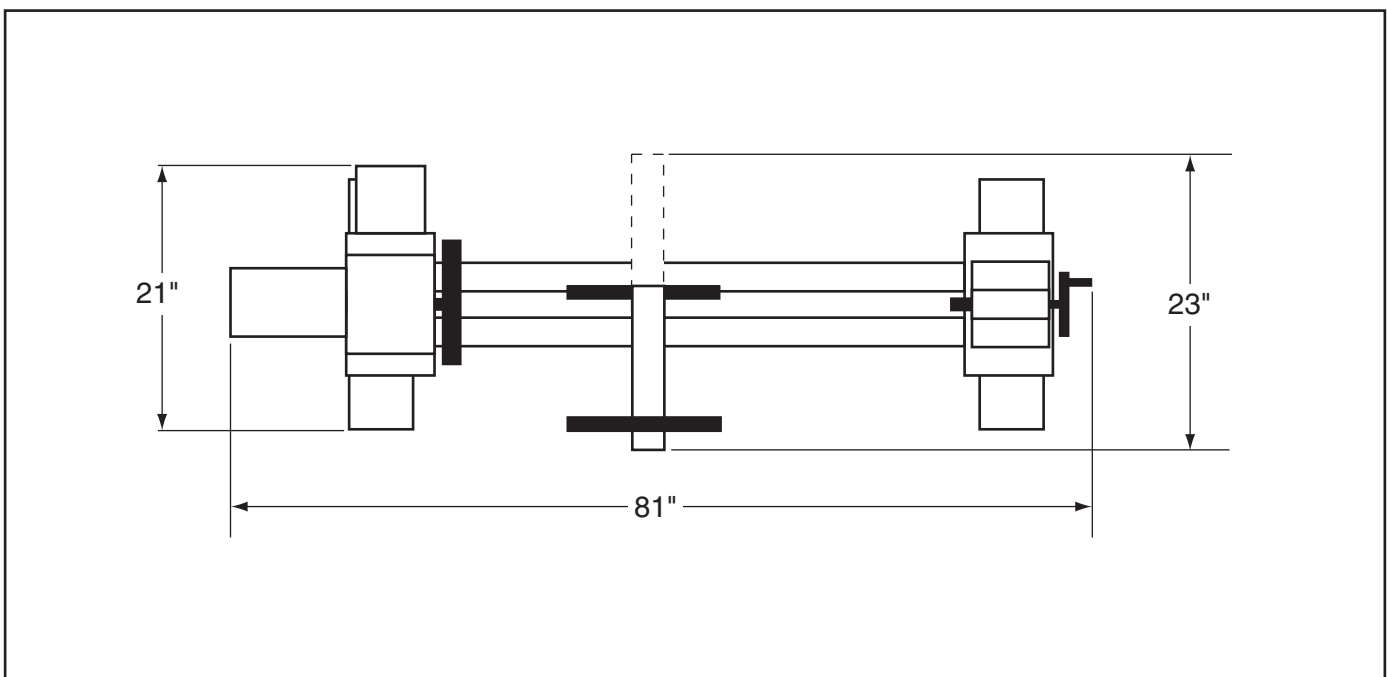

Figure 9. Minimum working clearances.



Anchoring to Floor

Number of Mounting Holes 4
Diameter of Mounting Hardware..... 1/2"

Anchoring machinery to the floor prevents tipping or shifting and reduces vibration that may occur during operation, resulting in a machine that runs slightly quieter and feels more solid.

If the machine will be installed in a commercial or workplace setting, or if it is permanently connected (hardwired) to the power supply, local codes may require that it be anchored to the floor.

If not required by any local codes, fastening the machine to the floor is an optional step. If you choose not to do this with your machine, we recommend placing it on machine mounts, as these provide an easy method for leveling and they have vibration-absorbing pads.

Anchoring to Concrete Floors

Lag shield anchors with lag screws (see below) are a popular way to anchor machinery to a concrete floor, because the anchors sit flush with the floor surface, making it easy to unbolt and move the machine later, if needed. However, anytime local codes apply, you **MUST** follow the anchoring methodology specified by the code.

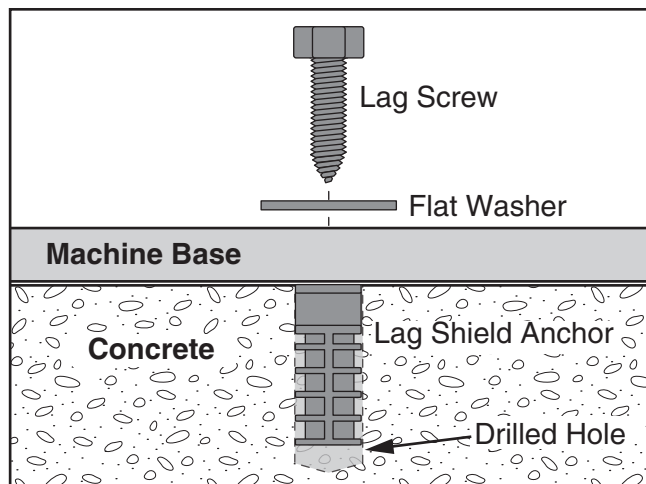

Figure 10. Popular method for anchoring machinery to a concrete floor.

Assembly

To assemble lathe:

1. Position stand legs upright approximately 58" apart, and get them reasonably aligned (see **Figure 11**).

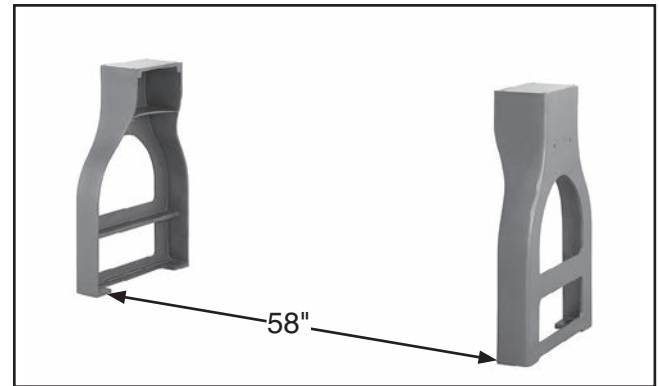

Figure 11. Supporting legs.

2. Carefully position lathe assembly on top of stands and align mounting holes.
3. Secure lathe assembly to stand legs with (8) M10-1.25 x 35 cap screws and 10mm lock washers, as shown in **Figure 12**.

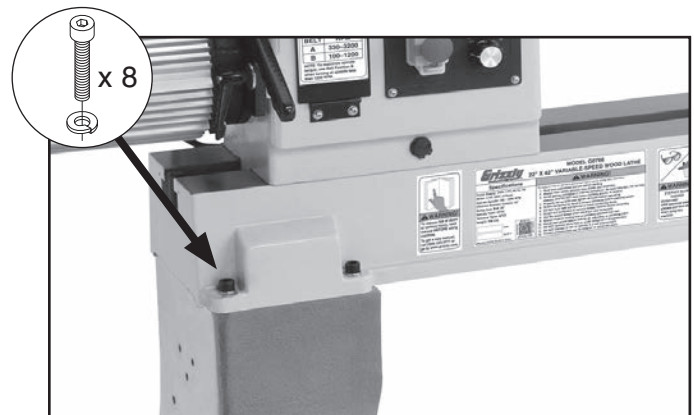

Figure 12. Securing lathe assembly.



4. If bolting lathe to floor, skip to **Step 7**. Otherwise, move tailstock, tool rest assembly, and headstock to one end of lathe bed way (refer to **Operations**, beginning on **Page 2020**).
5. Use assistants to lift one end of lathe onto support blocks and stabilize lathe in preparation for installing machine feet (see **Figure 13**).

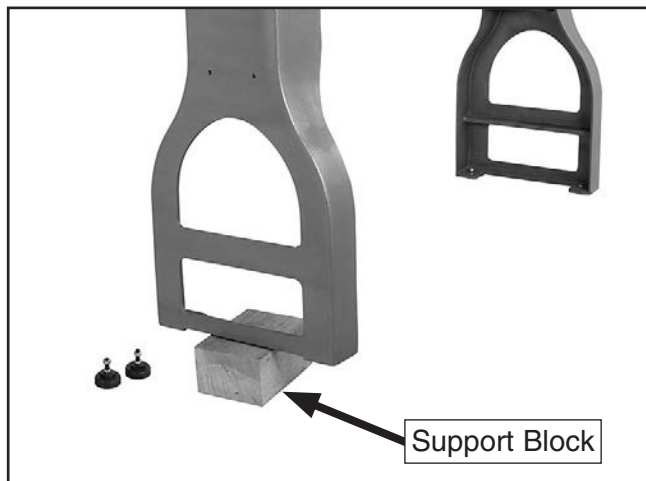

Figure 13. Legs supported for feet installation.

6. Remove top hex nut from feet, insert feet in mounting holes in leg (see **Figure 14**), then thread top hex nut back on. Do not tighten hex nuts yet. Remove supporting block and repeat **Steps 5–6** on other leg.



Figure 14. Machine feet installed.

7. Place level on lathe bed and make necessary adjustments so bed is level from side-to-side and front-to-back.
 - If you are using machine feet, adjust top and bottom hex nuts on each leg to level bed; then tighten hex nuts to secure these adjustments.
 - If you are bolting lathe to floor, use shims under legs to level bed; then tighten mounting fasteners.
8. Insert tool rest into tool rest base and tighten tool rest lock lever, as shown in **Figure 15**.

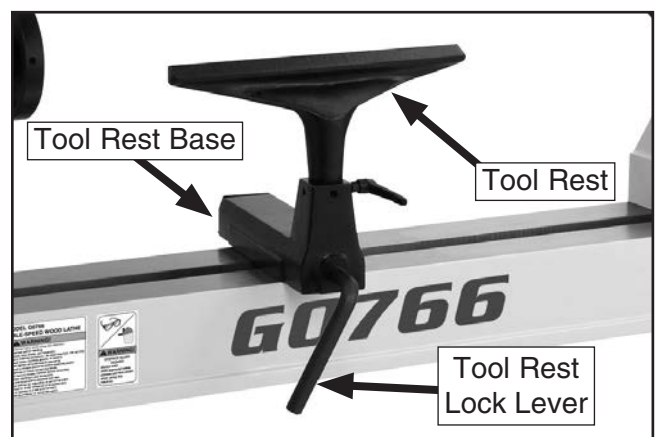

Figure 15. Tool rest installed on the tool rest base.



Test Run

Once assembly is complete, test run the machine to ensure it is properly connected to power and safety components are functioning correctly.

If you find an unusual problem during the test run, immediately stop the machine, disconnect it from power, and fix the problem BEFORE operating the machine again. The **Troubleshooting** table in the **SERVICE** section of this manual can help.

The test run consists of verifying the following:

- 1) The motor powers up and runs correctly, and
- 2) the safety disabling mechanism on the switch works correctly.

WARNING

Serious injury or death can result from using this machine BEFORE understanding its controls and related safety information. DO NOT operate, or allow others to operate, machine until the information is understood.

WARNING

DO NOT start machine until all preceding setup instructions have been performed. Operating an improperly set up machine may result in malfunction or unexpected results that can lead to serious injury, death, or machine/property damage.

To test run machine:

1. Clear all setup tools away from machine.
2. Connect machine to power supply.
3. Set spindle direction switch to neutral or "O" position and turn speed control knob all the way counterclockwise.
4. Squeeze tab on bottom of Emergency Stop button, lift button to open switch cover, and press green ON button to start machine.

5. Verify machine is operating correctly by turning spindle direction switch to "R" position, then slowly turn speed control knob to right.

— When operating correctly, machine runs smoothly with little or no vibration or rubbing noises.

— Investigate and correct strange or unusual noises or vibrations before operating machine further. Always disconnect machine from power when investigating or correcting potential problems.

6. Turn speed control knob all the way left.

7. Turn spindle direction switch to "L" position, and slowly turn speed control knob to right.

— When operating correctly, machine runs smoothly with little or no vibration or rubbing noises.

8. Move spindle direction switch to "O" position, and push in Emergency Stop button.

9. Without opening Emergency Stop button, turn spindle direction switch to "R" and "L" positions. Machine should not start at either position.

— If machine *does not* start, Emergency Stop button safety feature is working correctly. Test run is complete.

— If machine *does* start (with Emergency Stop button pushed in), immediately disconnect power to machine. Emergency Stop button safety feature is not working correctly. This safety feature must work properly before proceeding with regular operations. Call Tech Support for help.



SECTION 4: OPERATIONS

Operation Overview

The purpose of this overview is to provide the novice machine operator with a basic understanding of how the machine is used during operation, so the machine controls/components discussed later in this manual are easier to understand.

Due to the generic nature of this overview, it is **not** intended to be an instructional guide. To learn more about specific operations, read this entire manual and seek additional training from experienced machine operators, and do additional research outside of this manual by reading "how-to" books, trade magazines, or websites.

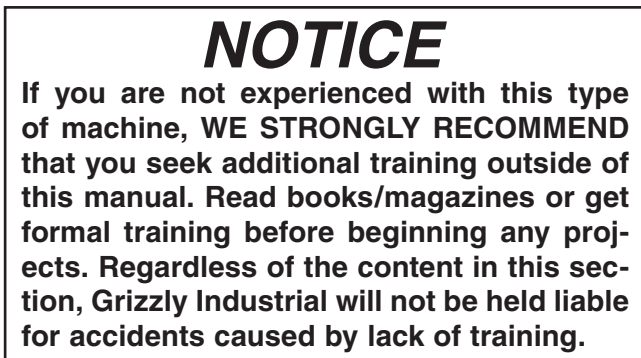
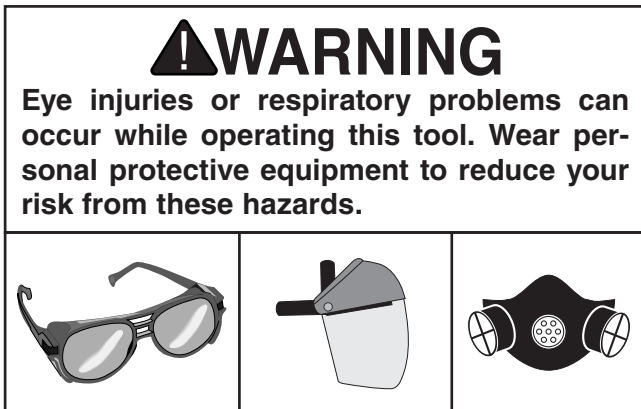

To complete a typical operation, the operator does the following:

1. Examines workpiece to make sure it is suitable for turning. No extreme bows, knots, or cracks should exist.
2. Prepares and trims up workpiece with a bandsaw or table saw to make it roughly concentric.
3. Installs workpiece between centers, or attaches it to faceplate or chuck.
4. Adjusts tool rest to $\frac{1}{8}$ " above workpiece centerline, and sets minimum clearance between workpiece and lip of tool rest to $\frac{1}{4}$ " gap.
5. Rotates workpiece by hand to verify spindle and workpiece rotate freely throughout full range of motion.
6. Verifies pulley ratio is set for type of wood and size of workpiece installed.
7. Verifies spindle speed dial is turned all the way counterclockwise so spindle does not start in high speed.
8. Verifies spindle direction switch is set for correct direction.
9. Puts on safety glasses, face shield, and respirator.
10. Turns lathe **ON**, adjusts lathe speed, and carefully begins turning operation, keeping chisel against tool rest entire time it is cutting.
11. Turns lathe **OFF** when cutting operation is complete.



Workpiece Inspection

Some workpieces are not safe to turn or may require modification before they are safe to turn.

Before turning, inspect all workpieces for the following:

- **Workpiece Type:**

This machine is intended for turning natural wood products. Never attempt to turn any composite wood materials, plastics, metal, stone, or rubber workpieces; turning these materials can lead to machine damage or severe injury.

- **Foreign Objects:**

Nails, staples, dirt, rocks and other foreign objects are often embedded in wood. While cutting, these objects can become dislodged and hit the operator, cause tool grab, or break the turning tool, which might then fly apart. Always visually inspect your workpiece for these items. If they can't be removed, DO NOT turn the workpiece.

- **Large/Loose Knots:**

Loose knots can become dislodged during the turning operation. Large knots can cause a workpiece to completely break in half during turning and cause machine damage and injury. Choose workpieces that do not have large/loose knots.

- **Excessive Warping:**

Workpieces with excessive bowing or twisting are unstable and unbalanced. Never turn these workpieces at high speed, or instability will be magnified and the workpiece can be ejected from the lathe causing injury. Only turn concentric workpieces!

Adjusting Headstock

The Model G0766 headstock is equipped with a cam-action clamping system to secure it to the lathe bed. When the lever is tightened, a locking plate lifts up underneath the bed and secures the tailstock in place. The headstock can be positioned anywhere along the lathe bed.

To position headstock along length of bed:

1. DISCONNECT MACHINE FROM POWER!
2. Loosen headstock lock lever (see **Figure 16**).

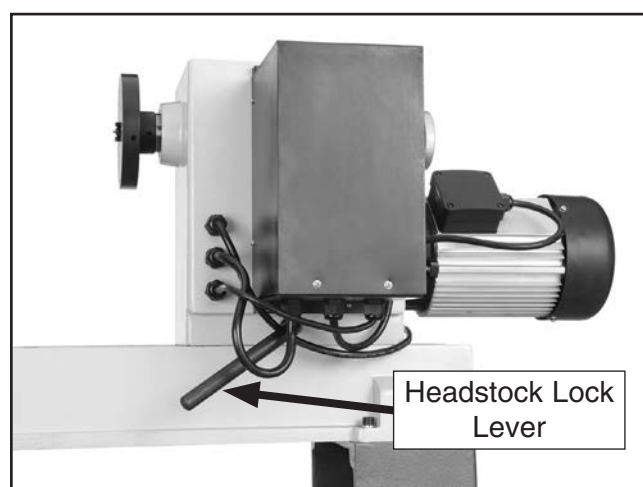

Figure 16. Headstock lock lever location.

3. Slide headstock to desired location on bed, and use headstock lock lever to secure headstock in position.

Note: *The large clamping hex nut underneath the headstock will require occasional adjusting to ensure proper clamping pressure of the headstock to the bed. Turn this hex nut in small increments to fine tune the clamping pressure as needed.*

!WARNING

Always operate lathe with headstock firmly locked to bed. Otherwise, serious personal injury may occur, as workpiece or faceplate could shift during operation or be ejected from lathe.



Adjusting Tailstock

The tailstock adjusts in the same manner as the headstock.

To position tailstock along length of bed:

1. Loosen tailstock lock lever and move tailstock to desired position along bed, as shown in **Figure 17**.

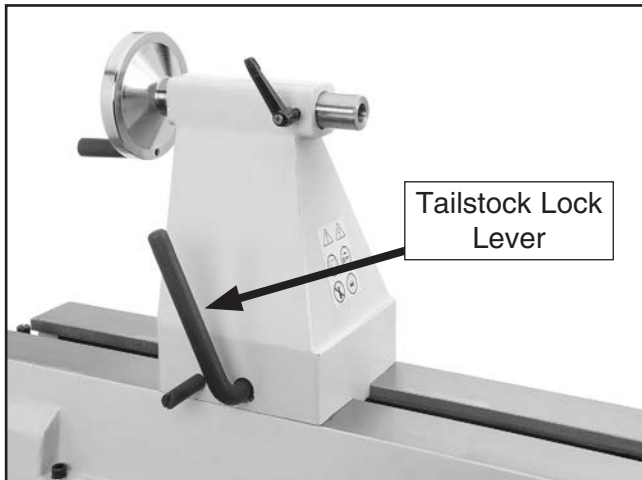

Figure 17. Tailstock lock lever location.

2. Re-tighten tailstock lock lever to secure tailstock to bed.

Note: *The large clamping hex nut underneath the tailstock will require occasional adjusting to ensure proper clamping pressure of the tailstock to the bed. Turn this hex nut in small increments to fine tune the clamping pressure as needed.*

!WARNING

Always operate lathe with tailstock firmly locked to bed. Otherwise, serious personal injury may occur by tailstock moving during operation and workpiece being ejected at high speed.

Adjusting Tool Rest

The tool rest assembly consists of two components: the tool rest base (or banjo) and the tool rest. The tool rest base moves forward/backward and along the length of the lathe bed. The tool rest rotates and moves up and down in the tool rest base. Locks for both components allow you to secure the tool rest in position as needed after making these adjustments.

When adjusting the tool rest, position it as close as possible to the workpiece without actually touching it. This maximizes support where the cutting occurs and minimizes leverage, reducing the risk of injury if a "catch" occurs.

Many woodturners typically set the height of the tool rest $\frac{1}{8}$ " above or below the centerline of the workpiece, depending on their height, the type of tool they're using, and the type of operation they're performing. As a rule of thumb: For most (spindle) turning operations, the cutting tool should contact the workpiece slightly above centerline. For most inside (bowl) turning operations, the cutting tool should contact the workpiece slightly below centerline.

Keeping all these factors in mind, your main goal when adjusting the tool rest should be providing maximum support for the type of tool being used, in a position that is safe and comfortable for you.

!WARNING

Improperly supported or positioned cutting tools can "catch" on workpiece, ejecting tool from your hands with great force. To reduce this risk, always ensure tool rest is properly positioned for each type of operation, cutting tool is firmly supported against tool rest **BEFORE** cutting, and cutting tool is properly positioned to cut at the correct angle for tool and operation type.



To position tool rest forward/backward and along the length of the bed:

1. Loosen tool rest base lock lever and move tool rest assembly to desired position on lathe bed, as shown in **Figure 18**.

Note: To maximize support, the tool rest base should always be locked on both sides of the bed. Never pull the tool rest so far back that it is only secured on one side.

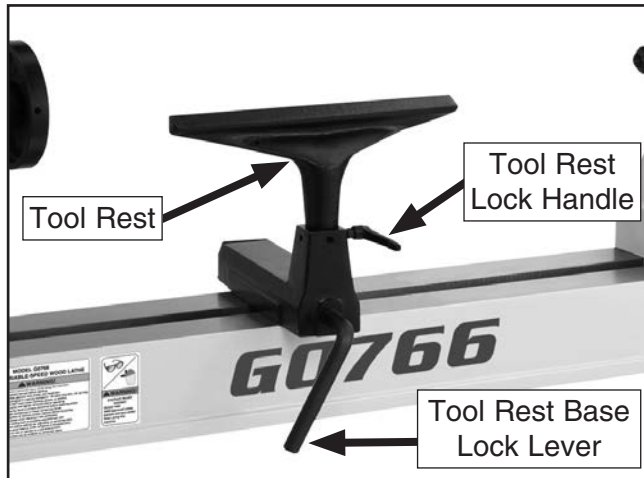

Figure 18. Tool rest controls.

2. Re-tighten tool rest base lock lever to secure tool rest assembly in position.

Note: The large clamping hex nut underneath the tool rest base will require occasional adjusting to ensure proper clamping pressure of the tool rest assembly to the bed. Turn this hex nut in small increments to fine tune the clamping pressure as needed.

!WARNING

Always operate lathe with tool rest assembly firmly locked in position. Otherwise, serious personal injury may occur by tool being pulled from operator's hands.

To adjust angle or height of tool rest:

1. Loosen tool rest lock handle (see **Figure 18**).
2. Position tool rest in desired location.
3. Re-tighten tool rest lock handle to secure tool rest in position.



Installing/Removing Headstock Center

The included spur center installs in the headstock spindle with an MT#2 tapered fit.

Installing Headstock Center

1. DISCONNECT MACHINE FROM POWER!
2. Make sure mating surfaces of center and spindle are free of debris and oily substances before inserting center to ensure a good fit and reduce runout.
3. Insert tapered end of center into spindle, and push it in with a quick, firm motion, as shown in **Figure 19**.

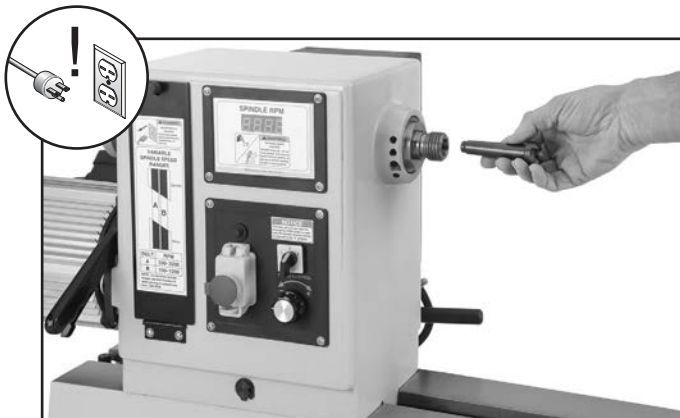

Figure 19. Installing center in headstock spindle.

4. Make sure center is securely installed by attempting to pull it out by hand—a properly installed center will not pull out easily.

Removing Headstock Center

1. DISCONNECT MACHINE FROM POWER!
2. Hold a clean rag under spindle or wear leather glove to catch center when you remove it.
3. Insert knockout tool through outbound end of spindle and firmly tap back of center, catching it as it falls, as shown in **Figure 20**.



Figure 20. Removing the headstock center.



Installing/Removing Tailstock Center

The included live center installs into the tailstock quill with an MT#2 tapered fit.

Installing Tailstock Center

1. Loosen quill lock handle, and rotate handwheel until quill extends about 1", as shown in **Figure 21**.

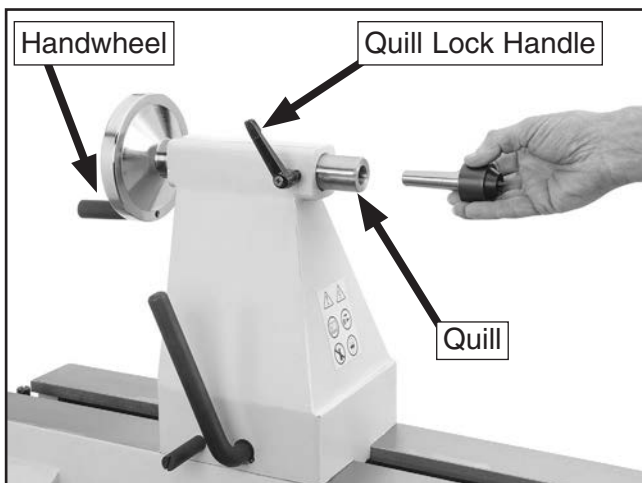

Figure 21. Installing center into tailstock quill.

2. Make sure mating surfaces of center and quill are free of debris and oily substances before inserting center to ensure a good fit and reduce runout.
3. Firmly insert tapered end of center into tailstock quill, as shown in **Figure 21**.
4. Make sure center is securely installed by attempting to pull it out by hand—a properly installed center will not pull out easily.

5. Make sure center of quill lock handle is aligned with quill keyway to ensure tailstock center and quill will not freely rotate under load (see **Figure 22**).

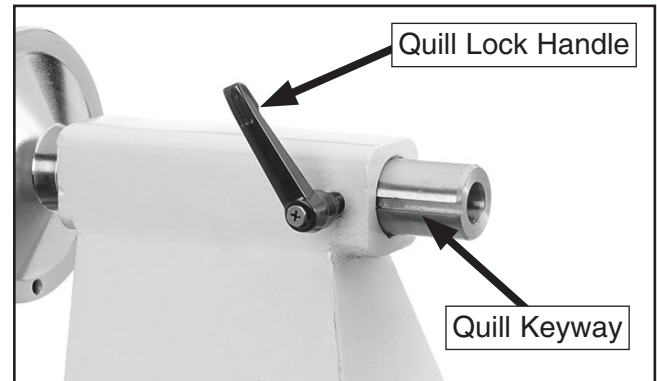

Figure 22. Quill lock handle aligned with quill keyway.

6. Secure quill in place by re-tightening quill lock handle.

Removing Tailstock Center

1. Loosen quill lock handle.
2. Hold a clean rag under spindle or wear a glove to catch center when you remove it.
3. Rotate handwheel counterclockwise—tailstock quill will retract back into quill, causing center to be forced out.

!WARNING

Tailstock quill must always be locked in place during lathe operation. Before tightening quill lock handle, it must be properly aligned with quill keyway. Otherwise, workpiece can be thrown from lathe causing serious personal injury or death.



Installing Faceplate

To install faceplate:

1. DISCONNECT MACHINE FROM POWER!
2. Insert indexing pin into an indexing hole and rotate spindle until pin engages to prevent spindle from turning while you tighten faceplate, as shown in **Figure 23**.

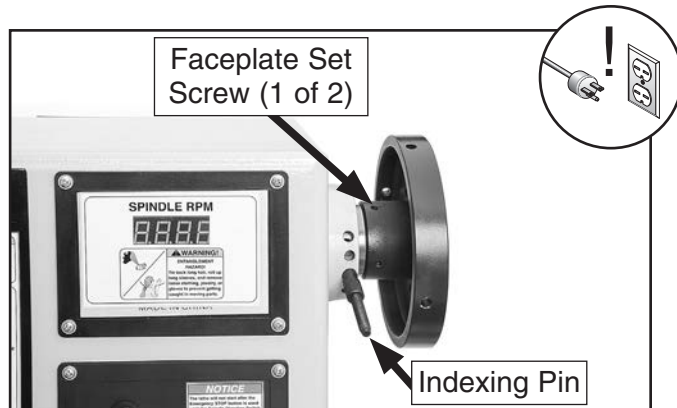

Figure 23. Locking spindle with indexing pin and faceplate set screw.

3. Thread faceplate onto spindle until it is snug.
4. Using included 4mm hex wrench, tighten two set screws along inside diameter of faceplate to secure it to spindle (see **Figure 23**).

!WARNING

To prevent faceplate and workpiece separating from spindle during operation, headstock faceplate **MUST** be firmly threaded onto spindle and secured in place by fully tightening the two faceplate set screws. If these instructions are not properly performed, serious personal injury could occur.

Note: To remove faceplate, disconnect lathe from power source and perform steps above in reverse.

Changing Speed Ranges

The Model G0766 pulley belt configurations provide two speed ranges (see **Figure 24**).

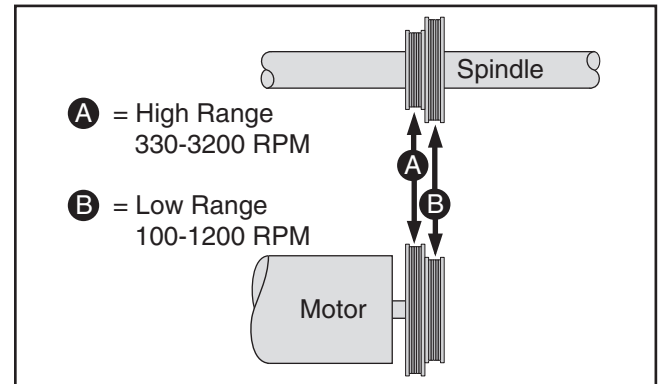

Figure 24. Speed range belt positions.

Note: To maximize spindle torque, use low spindle speed range for spindle speeds of 1200 RPM or less.

Refer to speed recommendations chart in **Figure 25** to choose appropriate RPM for your operation. Then choose speed range that will include selected RPM.

Diameter of Work-piece	Roughing RPM	General Cutting RPM	Finishing RPM
Under 2"	1520	3200	3200
2-4"	760	1600	2480
4-6"	510	1080	1650
6-8"	380	810	1240
8-10"	300	650	1000
10-12"	255	540	830
12-14"	220	460	710
14-16"	190	400	620

Figure 25. Model G0766 speed recommendations.



! WARNING

Always choose correct spindle speed for an operation. Using wrong speed may lead to workpiece being thrown at high speed, causing fatal or severe impact injuries.

To change speed ranges:

1. DISCONNECT MACHINE FROM POWER!
2. Open front belt access cover, as shown in **Figure 26**.

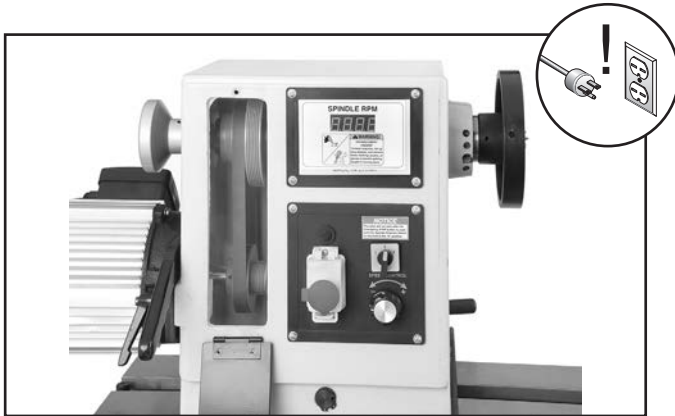

Figure 26. Belt access cover removed.

3. Loosen belt tension lock handle (see **Figure 27**).

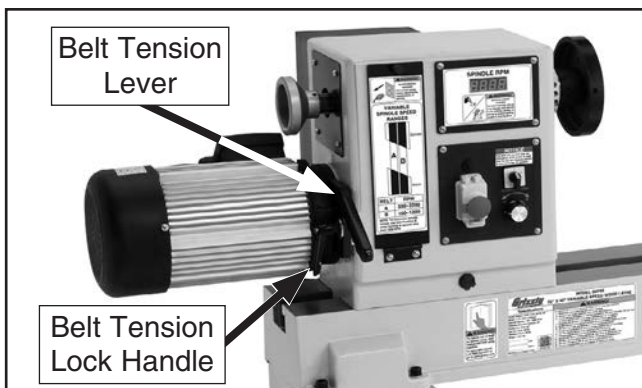

Figure 27. Motor tensioning handle and tension lock handle.

4. Use belt tension lever (see **Figure 27**) to lift motor assembly all the way up, then re-tighten belt tension lock handle—this will hold motor in place while you change belt position.

5. Reach into belt access cavity and roll belt onto desired set of pulleys, as shown in **Figure 28**.

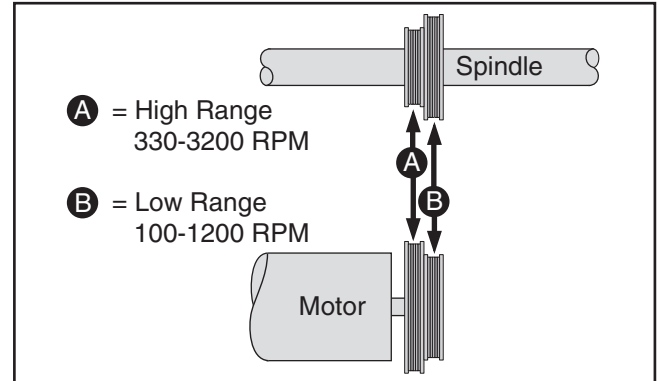

Figure 28. Speed range belt positions.

6. Loosen belt tension lock handle and lower motor.
7. Apply downward pressure on belt tension lever to properly tension drive belt, then re-tighten belt tension lock handle.

Note: When properly tensioned, belt should deflect about $\frac{1}{8}$ " when moderate pressure is applied to belt mid-way between upper and lower pulley, as shown in **Figure 29**.

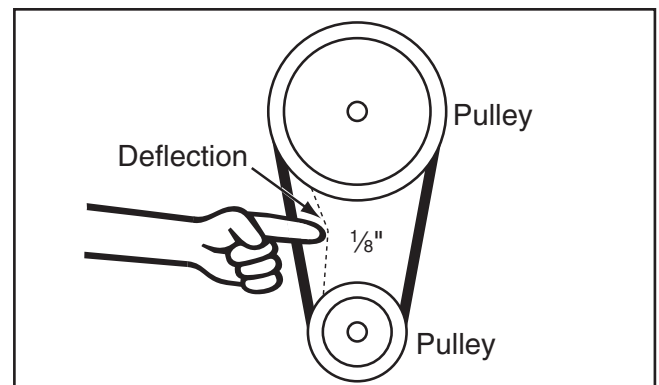

Figure 29. Testing for $\frac{1}{8}$ " belt deflection.

8. Replace front belt access cover.



Indexing

Indexing on a lathe is typically used for workpiece layout and other auxiliary operations that require equal distances around the workpiece circumference, such as clock faces or inlays.

By inserting the indexing pin into one of the four outer indexes of the Model G0766 spindle housing and engaging one of the 12 inner indexes in the spindle, the workpiece can be positioned in 10° increments, as shown in **Figures 30–31**.

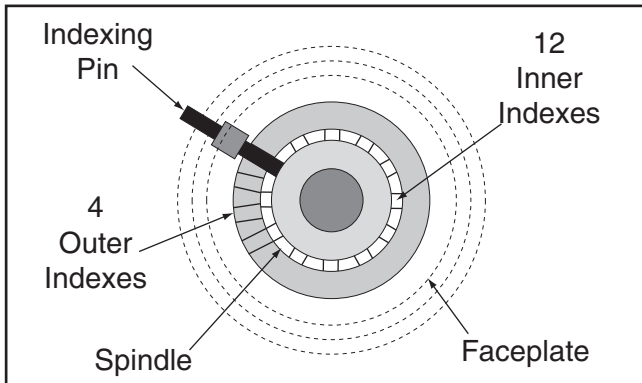

Figure 30. Model G0766 indexing configuration.

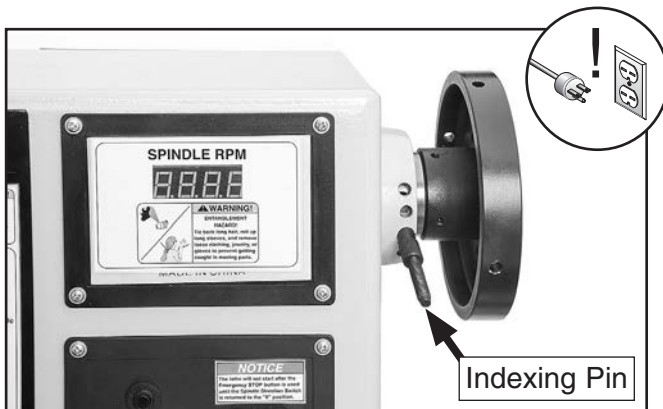

Figure 31. Indexing pin and indexing holes.

CAUTION

Always disconnect lathe from power before using indexing feature. **DO NOT** start lathe with indexing pin inserted into spindle; otherwise entanglement injury and property damage could occur.

Spindle Turning

Spindle turning is the operation performed when a workpiece is mounted between the headstock and the tailstock, as shown in **Figure 32**.

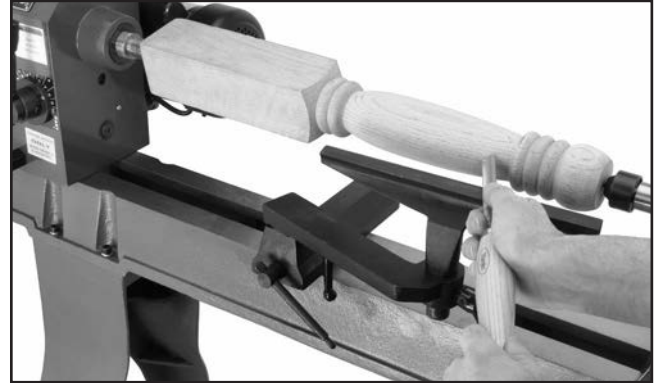

Figure 32. Typical spindle turning operation.

WARNING

Damage to your eyes and lungs could result from using this machine without proper protective gear. Always wear safety glasses, a face shield, and a respirator when operating this machine.

To set up a spindle turning operation:

1. Find center point of both ends of your workpiece by drawing diagonal lines from corner to corner across end of workpiece, as shown in **Figure 33**.

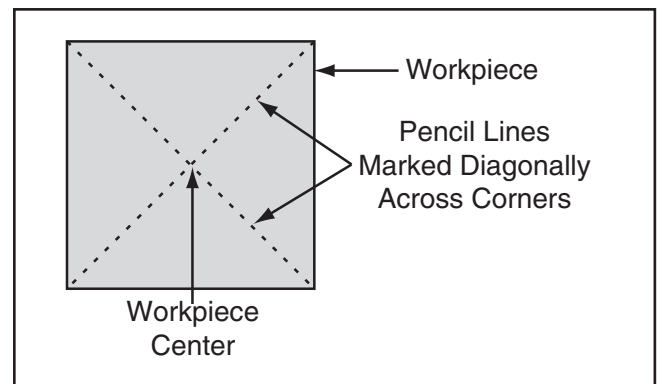

Figure 33. Workpiece marked diagonally from corner to corner to determine the center.



2. Make a center mark by using a wood mallet and tapping point of spur center into center of workpiece on both ends.
3. Using a 1/4" drill bit, drill a 1/4" deep hole at center mark on end of the workpiece to be mounted on headstock spur center.
4. To help embed spur center into workpiece, cut 1/8" deep saw kerfs in headstock end of workpiece along diagonal lines marked in **Step 1**.
5. If your workpiece is over 2" x 2", cut corners off workpiece lengthwise to make turning safer and easier (see **Figure 34**).

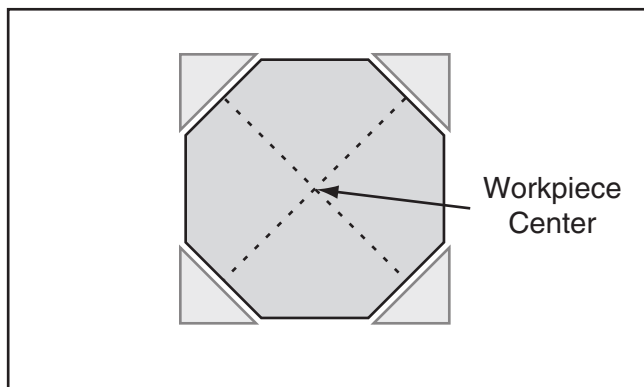

Figure 34. Corners of workpiece removed.

6. Drive spur center into end center mark of workpiece with a wood mallet to embed it at least 1/4" into workpiece, as shown in **Figure 35**.

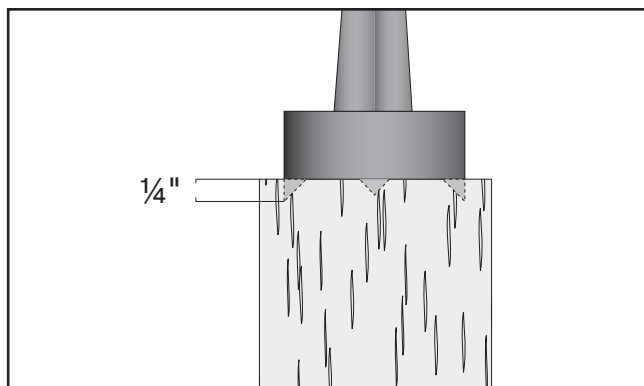

Figure 35. Spur center properly embedded.

7. With workpiece still attached, insert spur center into headstock spindle (refer to **Installing/Removing Headstock Center** on **Page 24** for additional instructions).

Note: Use tool rest to support opposite end of workpiece so that workpiece and spur center do not separate during installation.

8. Install live center into tailstock quill and tighten quill lock handle to lock quill in position (refer to **Page 25** for additional instructions).
9. Slide tailstock toward workpiece until point of live center touches workpiece center mark, then lock tailstock in this position.
10. Loosen quill lock handle and rotate tailstock handwheel to push live center into workpiece at least 1/4".

!WARNING

Do not press the workpiece too firmly with the tailstock or the bearings will bind and overheat. Do not adjust the tailstock too loosely or the workpiece will spin off the lathe. Use good judgment and care, otherwise, serious personal injury could result from the workpiece being ejected at high speeds.

11. Properly adjust tool rest to workpiece (see **Adjusting Tool Rest** on **Page 22**).
12. Before beginning lathe operation, rotate workpiece by hand to ensure there is safe clearance on all sides.

!WARNING

Keep lathe tool resting on tool rest the ENTIRE time it is in contact with workpiece or when preparing to make contact between lathe tool and workpiece. Otherwise, spinning workpiece could force lathe tool out of your hands or entangle your hands with workpiece. Failure to heed this warning could result in serious personal injury.



Spindle Turning Tips:

- When turning the lathe **ON**, stand away from the path of the spinning workpiece until the spindle reaches full speed and you can verify that the workpiece will not come loose.
- Use the slowest speed when starting or stopping the lathe.
- Select the right speed for the size of workpiece that you are turning (refer to **Figure 25** on **Page 26**).
- Keep the turning tool on the tool rest the **ENTIRE** time that it is in contact with the workpiece.
- Learn the correct techniques for each tool you will use. If you are unsure about how to use the lathe tools, read books or magazines about lathe techniques, and seek training from experienced and knowledgeable lathe users.

!WARNING

Eye injuries or respiratory problems can occur while operating this tool. Wear personal protective equipment to reduce your risk from these hazards.

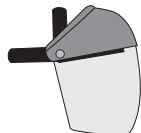

Faceplate Turning

Faceplate turning is when a workpiece is mounted to the faceplate, which is then mounted to the headstock spindle, as shown in **Figure 36**. This type of turning is usually done with open-faced workpieces like bowls or plates.

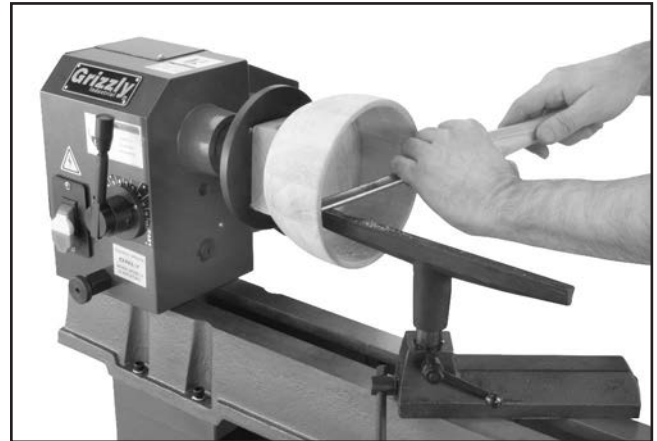

Figure 36. Typical faceplate turning operation.

Mounting Workpiece on Faceplate

1. Mark workpiece center in same manner as described in **Spindle Turning** (see **Page 28**).

Note: Cut off corners of workpiece to make it as close to "round" as possible, as described in **Spindle Turning, Step 5** (see **Page 29**).

2. Center faceplate on workpiece and attach it (see **Figure 37**) with wood screws.



Figure 37. Typical attachment of faceplate to workpiece.



NOTICE

Only use screws with non-tapered heads (see Figure 38) to attach faceplate to the workpiece. Screws with tapered heads can split faceplate or snap off during operation.

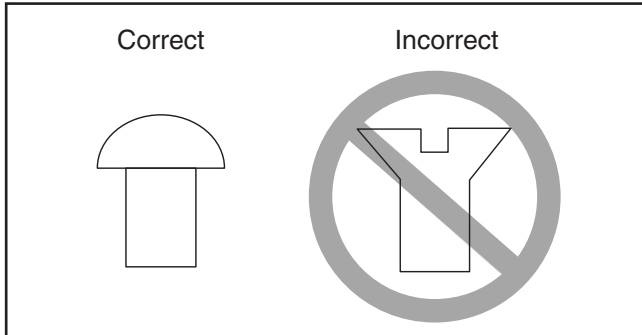

Figure 38. Correct and incorrect screw types.

3. Thread and secure faceplate onto headstock spindle (refer to **Installing Faceplate** on **Page 26**).

— If wood screws cannot be placed in workpiece, faceplate can be mounted to a backing block attached to workpiece (see **Mounting the Workpiece to a Backing Block**).

Mounting Workpiece to Backing Block

1. Make backing block from a suitable size piece of scrap wood.

Note: *Faces of backing block must be flat and parallel to each other, or uneven surfaces will cause workpiece to spin eccentrically, causing unnecessary vibration and runout. It is best to mount backing block to faceplate and turn other surface flat prior to mounting.*

2. Locate and mark center of workpiece and backing block.
3. Drill a ¼" hole through center of backing block.
4. Look through hole in backing block to line up center with workpiece and glue and clamp backing block to workpiece.

Note: *Allow glue to cure according to manufacturer's instructions.*

5. Follow **Steps 1–3** under **Mounting Workpiece on Faceplate** (see **Page 30**) to attach backing block to faceplate.

Outboard Turning

Outboard turning is a variation of faceplate turning and is accomplished with the headstock positioned so the faceplate is not directly over the bed, allowing a larger turning capacity than the swing specification of the lathe.

The only way to rotate the headstock on this machine is to remove it from the bed first, which can be a heavy and cumbersome task. A much simpler alternative to removing the headstock is to remove the tailstock and slide the headstock to the other end of the bed. This will position the spindle so it is not directly over the bed whereby outboard turning can safely be accomplished.



To outboard turn:

1. DISCONNECT MACHINE FROM POWER!
2. Remove tailstock and tool base from machine by removing hex nuts and clamp washers located underneath assemblies, then lifting them from lathe bed.
3. Loosen headstock, then move it all the way to tail end of lathe bed, as shown in **Figure 39**.

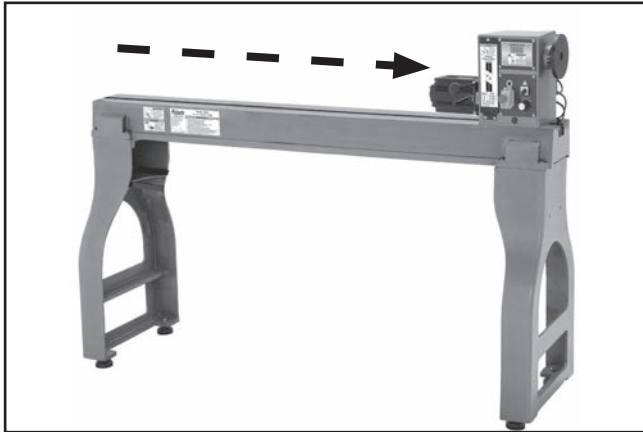

Figure 39. Example of lathe prepared for outboard turning.

4. Re-tighten headstock to bed.

!WARNING

When outboard turning, **ALWAYS** use a floor-mounted tool rest and keep tool in contact with rest during all turning operations. Failure to do so could cause tool to be pulled out of operator's control and ejected at high speed.

Sanding/Finishing

After the turning operations are complete, the workpiece can be sanded and finished before removing it from the lathe, as shown in **Figure 40**.

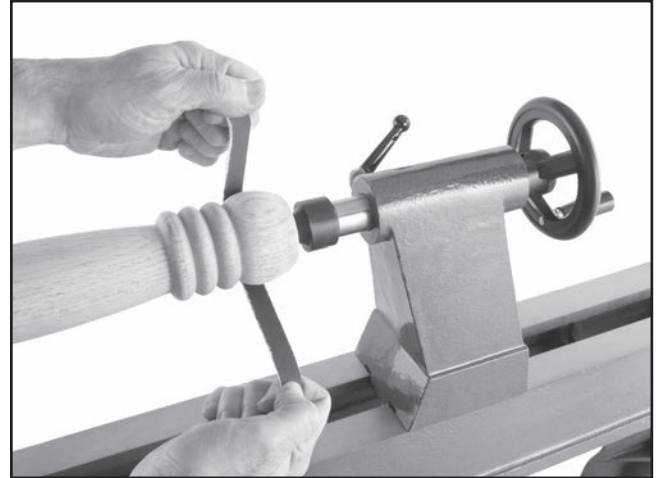

Figure 40. Typical sanding operation.

Note: Whenever sanding or finishing, move tool rest holder out of the way to increase personal safety and gain adequate working room.

A diagram showing a cross-section of a lathe workpiece. A piece of sandpaper is wrapped around the workpiece. Labels 'Sandpaper' and 'Workpiece' point to their respective parts. A diagonal line is drawn across the diagram, indicating that this practice is prohibited.	<h3>!WARNING</h3> <p>Wrapping sandpaper completely around workpiece could pull your hands into moving workpiece and may cause serious injury. Never wrap sandpaper or finishing materials completely around workpiece.</p>
---	---



Selecting Turning Tools

Lathe tools come in a variety of shapes and sizes, and usually fall into five major categories.

- **Gouges**—Mainly used for rough cutting, detail cutting, and cove profiles. The rough gouge is a hollow, double-ground tool with a round nose, and the detail gouge is a hollow, double-ground tool with either a round or pointed nose.

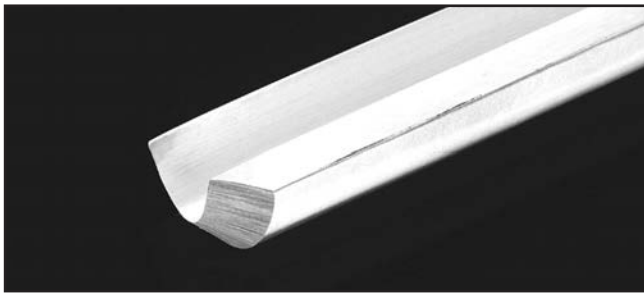

Figure 41. Example of a gouge.

- **Skew Chisel**—A very versatile tool that can be used for planing, squaring, V-cutting, beading, and parting off. The skew chisel is flat, double-ground with one side higher than the other (usually at an angle of 20°–40°).

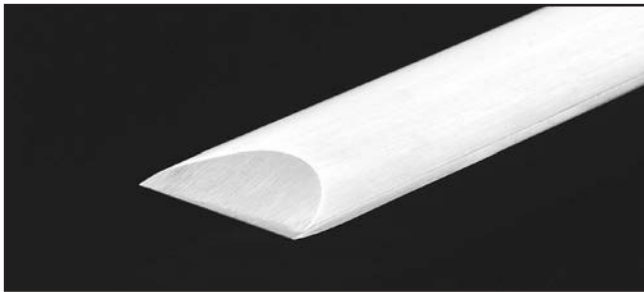

Figure 42. Example of a skew chisel.

- **Scrapers**—Typically used where access for other tools is limited, such as hollowing operations. This is a flat, double-ground tool that comes in a variety of profiles (round nose, spear point, square nose, etc.) to match many different contours.



Figure 43. Example of a round nose scraper.

- **Parting Tools**—Used for sizing and cutting off work. This is a flat tool with a sharp pointed nose that may be single- or double-ground.



Figure 44. Example of a parting tool.

- **Specialty Tools**—These are the unique, special function tools to aid in hollowing, bowl making, cutting profiles, etc. The Swan Neck Hollowing Tool shown on **Page 34** is a good example of a speciality tool.



SECTION 5: ACCESSORIES

!WARNING

Installing unapproved accessories may cause machine to malfunction, resulting in serious personal injury or machine damage. To reduce this risk, only install accessories recommended for this machine by Grizzly.

NOTICE

Refer to our website or latest catalog for additional recommended accessories.

Sovereign Turning System

Sovereign is a new handle and tool system allowing the turner to customize the tools they need for the type of turning they do. Sold with or without $\frac{3}{8}$ " and $\frac{1}{2}$ " collet options, plus the gamut of tool tips will make you wonder how you managed without a Sovereign. All tools are high speed steel construction for long life and dependable use. Below are just some of the options available with this system.

- T21644—16" Sovereign System w/Collets**
- T21645—22" Sovereign System w/Collets**
- T21648—Sovereign $\frac{3}{8}$ " Collets**
- T21649—Sovereign $\frac{1}{2}$ " Collets**
- T21654— $\frac{1}{4}$ " Bowl Gouge**
- T21655— $\frac{3}{8}$ " Bowl Gouge**
- T21656— $\frac{1}{2}$ " Bowl Gouge**
- T21660— $\frac{3}{4}$ " Bowl Gouge**



Figure 45. Sovereign 16" and 22" handles.

D3788—Shop Fox 5-pc. Lathe Chisel Set

With massive high speed steel blades and long ash handles, this set includes a 1" roughing gouge, $\frac{3}{8}$ " straight chisel, swan neck hollowing tool, $\frac{3}{8}$ " spindle gouge, and $\frac{1}{8}$ " parting tool. Also includes a fitted aluminum case.

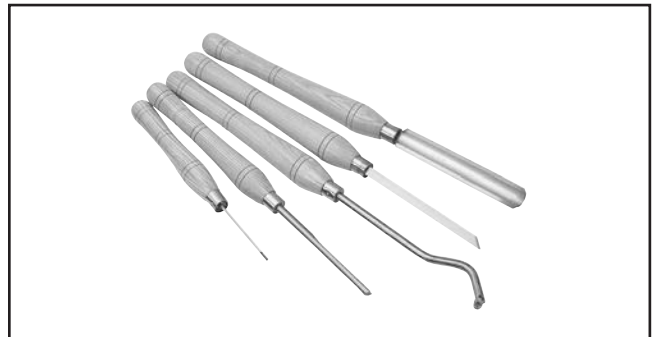

Figure 46. Model T23311 Shop Fox 5-pc. chisel set.

Basic Eye Protection

- T20501—Face Shield Crown Protector 4"**
- T20502—Face Shield Crown Protector 7"**
- T20503—Face Shield Window**
- T20451—"Kirova" Clear Safety Glasses**
- T20452—"Kirova" Anti-Reflective S. Glasses**
- H7194—Bifocal Safety Glasses 1.5**
- H7195—Bifocal Safety Glasses 2.0**
- H7196—Bifocal Safety Glasses 2.5**



Figure 47. Assortment of basic eye protection.

order online at www.grizzly.com or call 1-800-523-4777



T21771—Woodturning : A Foundation Course

Designed to improve your turning skills, this DVD provides basic turning techniques and practices in detailed step-by-step demonstrations you can follow along with. Topics include suitable workpiece and tool selection, copy turning, turning between centers of faceplate, sanding and fine finishing, and maintaining and edge on your tools.

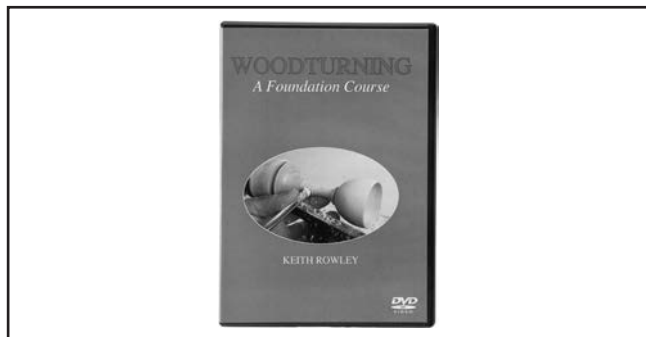

Figure 48. Model T21771 Woodturning DVD: A Foundation Course.

T10117—Big Mouth Dust Hood with Stand

Capture dust from any machine operation with this Big Mouth Dust Hood. Simply attach a 4" dust collection hose and adjust the hood right where you need it. The free standing base eliminates complicated machine set-ups and the tilting $16\frac{3}{8}$ " x $12\frac{7}{8}$ " hood adjusts from 23" to 43" high. Every shop needs one of these!



Figure 49. Model T10117 Big Mouth Dust Hood.

G9274—6" Stainless Steel Outside Calipers

G9275—8" Stainless Steel Outside Calipers

G9276—10" Stainless Steel Outside Calipers

G9277—12" Stainless Steel Outside Calipers

G9278—16" Stainless Steel Outside Calipers

Spring Calipers with quick adjustment nut provide fast determination of external measurements. Ideal for physically transferring dimensions from originals. Five different sizes allow you to match the best caliper for your shop needs.



Figure 50. Model G9278 16" Stainless Steel Calipers.

H5884—8" Pencil Divider

H5885—10" Pencil Divider

H5886—12" Pencil Divider

H5887—16" Pencil Divider

Transfer precise distances for highly accurate layouts. Bisect angles for precise angle measurements. Steel legs with fine points scribe most materials. Pencil holder converts dividers to a compass. Knurled knob locks dividers from 0–90°. Size indicates leg lengths.



Figure 51. Models H5884–H5887 Pencil Dividers.

order online at www.grizzly.com or call 1-800-523-4777



H7940—3-pc. Lathe Scraper Set

This set is ideal for bowl turning and detail work. Each chisel measures roughly 16" long with 10" ash handles and high speed steel blades. Set includes one round, one curved, and one 90° corner chisel.



Figure 52. Model H7940 3 Pc. Scraper Set.

G1069—Live Center Set

A blend of quality and convenience, this Live Center Set offers seven interchangeable tips. High quality needle bearings prolong tool life and special tool steel body and tips are precision-ground. Supplied in box. Morse Taper: #2.



Figure 53. Model G1069 Live Center.

Recommended Metal Protectants

G5562—SLIPIT® 1 Qt. Gel

G5563—SLIPIT® 12 Oz. Spray

G2871—Boeshield® T-9 12 Oz. Spray

G2870—Boeshield® T-9 4 Oz. Spray

H3788—G96® Gun Treatment 12 Oz. Spray

H3789—G96® Gun Treatment 4.5 Oz. Spray



Figure 54. Recommended products for protecting unpainted cast iron/steel part on machinery.

T21884—Turning Basics for Furniture Makers

As a veteran furniture maker, Steve Shanesy took up turning to expand the repertoire of his wood-working skills. After several years, and hundreds of projects later, Steve decided to create a DVD that would demonstrate the basics of spindle turning so that you too can expand the types of projects you build. This "trailer" shows all of the projects you'll learn to build and the skills you'll learn to master in this essential DVD.

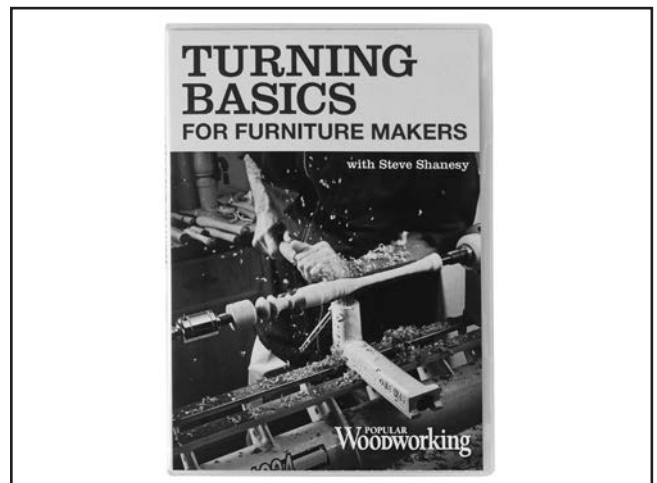
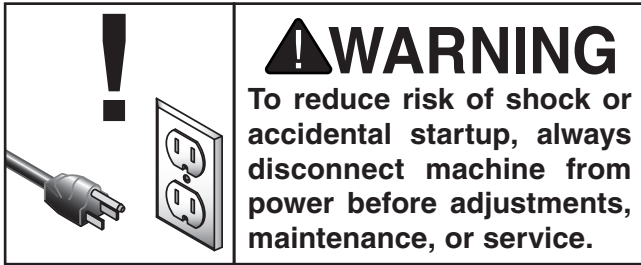

Figure 55. Model T21884 Turning Basics for Furniture Makers.



SECTION 6: MAINTENANCE



Schedule

For optimum performance from your machine, follow this maintenance schedule and refer to any specific instructions given in this section.

Ongoing:

- Loose faceplate or mounting bolts.
- Damaged center or tooling.
- Worn or damaged wires.
- Loose machine components.
- Any other unsafe condition.

Daily:

- Clean off dust buildup.
- Clean and lubricate lathe bed, spindle, and quill.

Monthly:

- Belt tension, damage, or wear.
- Clean out dust buildup from inside belt/pulley cavity.

Cleaning & Protecting

Cleaning the Model G0766 is relatively easy. Vacuum excess wood chips and sawdust, and wipe off the remaining dust with a dry cloth. If any resin has built up, use a resin dissolving cleaner to remove it.

Protect the unpainted cast iron surfaces by wiping them clean after every use—this ensures moisture from wood dust does not remain on bare metal surfaces. Keep the surfaces rust-free with regular applications of products like G96® Gun Treatment, SLIPIT®, or Boeshield® T-9 (see **Page 36** for more details).

Lubrication

All bearings for the Model G0766 are lubricated and sealed at the factory, and do not need additional lubrication.

Wipe a lightly oiled shop rag on the outside of the headstock spindle. **DO NOT** allow any oil to get on the inside mating surfaces of the spindle.

Use the tailstock handwheel to extend the quill out to the furthest position and apply a thin coat of white lithium grease to the outside of the quill. **DO NOT** allow any oil or grease to get on the inside mating surfaces of the quill.



SECTION 7: SERVICE

Review the troubleshooting and procedures in this section if a problem develops with your machine. If you need replacement parts or additional help with a procedure, call our Technical Support. **Note:** *Please gather the serial number and manufacture date of your machine before calling.*

Troubleshooting

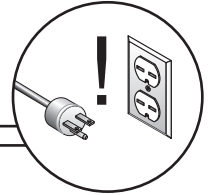

Motor & Electrical

Symptom	Possible Cause	Possible Solution
Machine does not start or a breaker trips.	<ol style="list-style-type: none"> Emergency stop button depressed/at fault. Incorrect power supply voltage or circuit size. Power supply circuit breaker tripped or fuse blown. Motor wires connected incorrectly. Wiring open/has high resistance. ON/OFF switch at fault. Potentiometer/variable-speed dial controller at fault. Inverter/control box at fault. Motor at fault. 	<ol style="list-style-type: none"> Press side tab in and lift switch cover. Press ON button to reset; replace if not working properly. Ensure correct power supply voltage and circuit size. Ensure circuit is sized correctly and free of shorts. Reset circuit breaker or replace fuse. Correct motor wiring connections. Check/fix broken, disconnected, or corroded wires. Replace switch. Test/replace. Inspect inverter/controller box; replace. Test/repair/replace.
Machine stalls or is underpowered.	<ol style="list-style-type: none"> Machine undersized for task (Wood). Workpiece material not suitable for machine. Feed rate/cutting speed too fast. Belt(s) slipping. Oil/grease on belt(s). Motor wired incorrectly. Plug/receptacle at fault. Motor overheated. Pulley slipping on shaft. 	<ol style="list-style-type: none"> Use sharp chisels; reduce feed rate/depth of cut. Only cut wood/ensure moisture is below 20%. Decrease feed rate/cutting speed. Tension/replace belt(s); ensure pulleys are aligned. Clean belt(s). Wire motor correctly. Test for good contacts/correct wiring. Clean motor, let cool, and reduce workload. Replace loose pulley/shaft.
Machine has vibration or noisy operation.	<ol style="list-style-type: none"> Motor or component loose. Belt worn or loose. Motor fan rubbing on fan cover. Motor mount loose/broken. Pulley loose. Machine incorrectly mounted or sits unevenly on floor. Motor bearings at fault. Belt slapping cover. Workpiece/faceplate at fault. 	<ol style="list-style-type: none"> Inspect/replace damaged bolts/nuts, and retighten with thread locking fluid. Inspect/replace belt. Fix/replace fan cover; replace loose/damaged fan. Tighten/replace. Re-align/replace shaft, pulley set screw, and key. Tighten/replace anchor studs in floor; relocate/shim machine; adjust feet. Test by rotating shaft; rotational grinding/loose shaft requires bearing replacement. Replace/realign belt. Center workpiece in chuck/faceplate; reduce RPM.



Wood Lathe Operation

Symptom	Possible Cause	Possible Solution
Bad surface finish.	<ol style="list-style-type: none"> 1. Spindle speed is wrong. 2. Dull tooling or wrong tool selection. 3. Tool height is not at spindle centerline. 4. Belts are bad. 	<ol style="list-style-type: none"> 1. Adjust for appropriate spindle speed. 2. Sharpen tooling or select a better tool for intended operation. 3. Adjust tool rest so tool is even with spindle centerline. 4. Replace belts.
Excessive vibration upon startup (when workpiece is installed).	<ol style="list-style-type: none"> 1. Workpiece is mounted incorrectly. 2. Workpiece is hitting stationary object. 3. Headstock, tailstock, or tool rest is not securely clamped to lathe bed. 4. Workpiece is warped, out of round, or flawed. 5. Spindle speed is set too fast for mounted workpiece. 6. Belt pulleys are not properly aligned. 7. Lathe is resting on an uneven surface. 8. Motor mount bolts are loose. 9. Belt is worn or damaged. 10. Spindle bearings are worn. 	<ol style="list-style-type: none"> 1. Remount workpiece, making sure that centers are embedded in true center of workpiece. 2. Stop lathe and fix interference problem. 3. Check clamp levers and tighten if necessary. 4. Cut workpiece to correct, or use a different workpiece. 5. Reduce spindle speed. 6. Align belt pulleys. 7. Shim stand or adjust feet on stand to remove any wobbling. 8. Tighten motor mount bolts. 9. Replace belt. 10. Replace spindle bearings.
Chisels grab or dig into workpiece.	<ol style="list-style-type: none"> 1. Wrong chisel/tool is being used. 2. Chisel/tool is dull. 3. Tool rest is set too low. 4. Tool rest is set too far from workpiece. 	<ol style="list-style-type: none"> 1. Use correct chisel/tool. 2. Sharpen or replace chisel/tool. 3. Set tool rest higher. 4. Move tool rest closer to workpiece.
Tailstock moves under load.	<ol style="list-style-type: none"> 1. Tailstock mounting bolt is loose. 2. Bed surface is oily or greasy. 	<ol style="list-style-type: none"> 1. Tighten mounting bolt. 2. Clean bed surface to remove excess oil/grease.
Spindle lacks turning power or starts up slowly.	<ol style="list-style-type: none"> 1. Belt is slipping. 	<ol style="list-style-type: none"> 1. Tighten/Adjust belt.
Quill will not move forward when handwheel is turned	<ol style="list-style-type: none"> 1. Keyway is not aligned with quill lock lever. 	<ol style="list-style-type: none"> 1. Align quill keyway and quill lock lever and slightly tighten lever to engage keyway.



Changing Belt

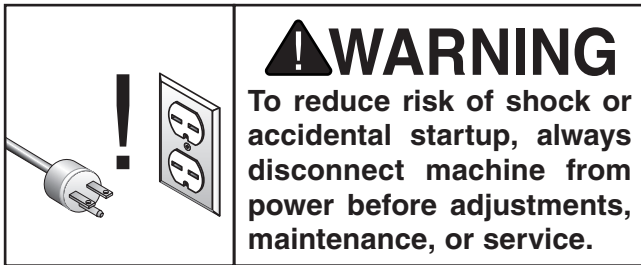

To change belt:

1. DISCONNECT MACHINE FROM POWER!
2. Open front belt access cover (see **Figure 56**).



Figure 56. Belt access cover opened.

3. Loosen belt tension lock handle (see **Figure 57**).

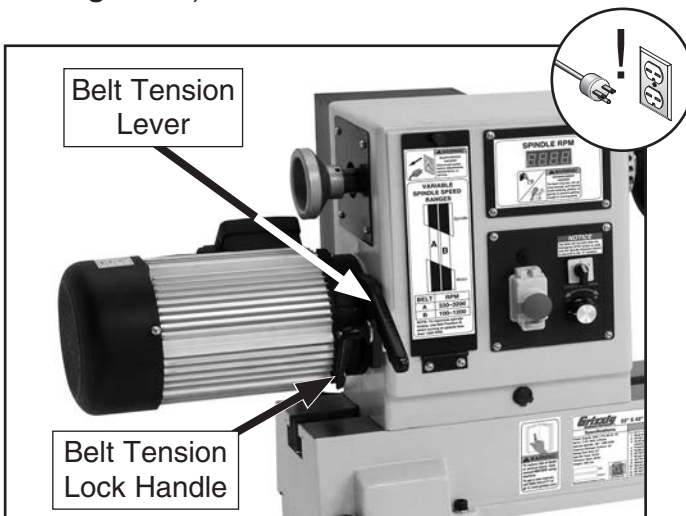

Figure 57. Location of belt tension lever and belt tension lock handle.

4. Use belt tension lever (see **Figure 57**) to lift motor assembly all the way up, then re-tighten motor tension lock handle—this will hold motor in place while you change belt position.
5. Reach into belt access cavity and roll belt off motor (lower) pulleys, then pull belt off spindle pulleys and through side of headstock.
6. Install new belt by performing **Step 5** in reverse.
7. Apply downward pressure on belt tension lever to properly tension drive belt, then re-tighten belt tension lock handle.

Note: When properly tensioned, belt should deflect about $\frac{1}{8}$ " when moderate pressure is applied to belt mid-way between upper and lower pulley, as illustrated in **Figure 58**.

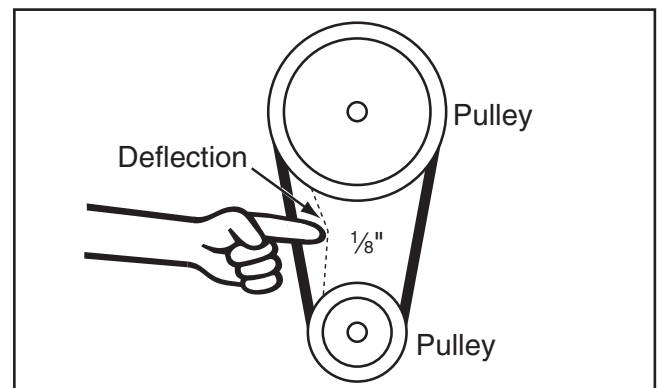

Figure 58. Testing for $\frac{1}{8}$ " belt deflection.

8. Ensure belt ribs are fully seated in pulley grooves, then secure front belt access cover.



SECTION 8: WIRING

These pages are current at the time of printing. However, in the spirit of improvement, we may make changes to the electrical systems of future machines. Compare the manufacture date of your machine to the one stated in this manual, and study this section carefully.

If there are differences between your machine and what is shown in this section, call Technical Support at (570) 546-9663 for assistance BEFORE making any changes to the wiring on your machine. An updated wiring diagram may be available. **Note:** *Please gather the serial number and manufacture date of your machine before calling. This information can be found on the main machine label.*

WARNING

Wiring Safety Instructions

SHOCK HAZARD. Working on wiring that is connected to a power source is extremely dangerous. Touching electrified parts will result in personal injury including but not limited to severe burns, electrocution, or death. Disconnect the power from the machine before servicing electrical components!

MODIFICATIONS. Modifying the wiring beyond what is shown in the diagram may lead to unpredictable results, including serious injury or fire. This includes the installation of unapproved after-market parts.

WIRE CONNECTIONS. All connections must be tight to prevent wires from loosening during machine operation. Double-check all wires disconnected or connected during any wiring task to ensure tight connections.

CIRCUIT REQUIREMENTS. You MUST follow the requirements at the beginning of this manual when connecting your machine to a power source.

WIRE/COMPONENT DAMAGE. Damaged wires or components increase the risk of serious personal injury, fire, or machine damage. If you notice that any wires or components are damaged while performing a wiring task, replace those wires or components.

MOTOR WIRING. The motor wiring shown in these diagrams is current at the time of printing but may not match your machine. If you find this to be the case, use the wiring diagram inside the motor junction box.















CAPACITORS/INVERTERS. Some capacitors and power inverters store an electrical charge for up to 10 minutes after being disconnected from the power source. To reduce the risk of being shocked, wait at least this long before working on capacitors.

EXPERIENCING DIFFICULTIES. If you are experiencing difficulties understanding the information included in this section, contact our Technical Support at (570) 546-9663.

NOTICE

The photos and diagrams included in this section are best viewed in color. You can view these pages in color at www.grizzly.com.

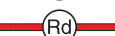
COLOR KEY

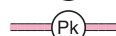
BLACK		BLUE		YELLOW		LIGHT BLUE	
WHITE		BROWN		YELLOW GREEN		BLUE WHITE	
GREEN		GRAY		PURPLE		TURQUOISE	
RED		ORANGE		PINK			



Wiring Diagram

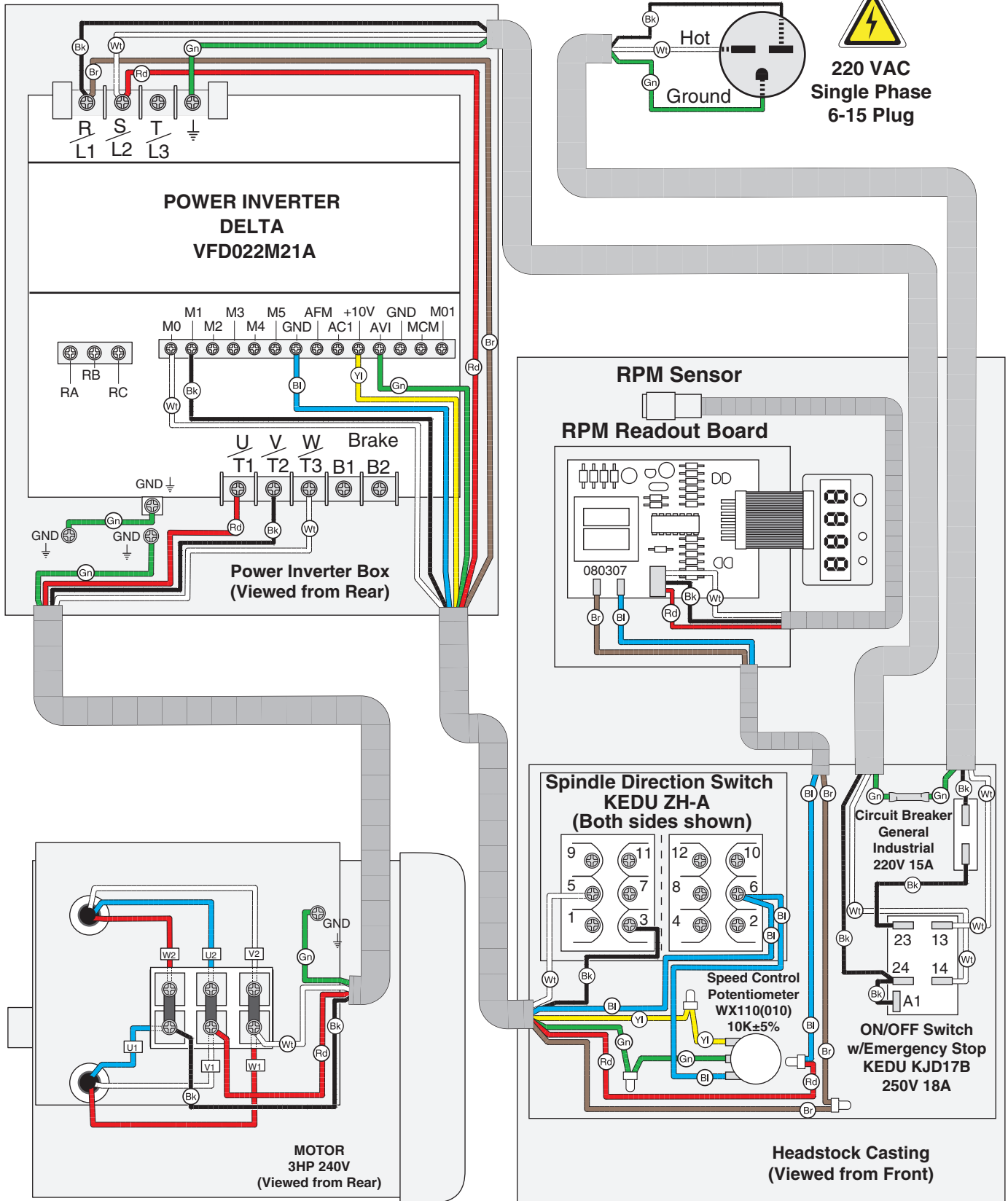

Wiring Components



Figure 59. Inverter box and motor box locations.



Figure 60. RPM readout display board and control panel wiring.

SECTION 9: PARTS

Main Breakdown

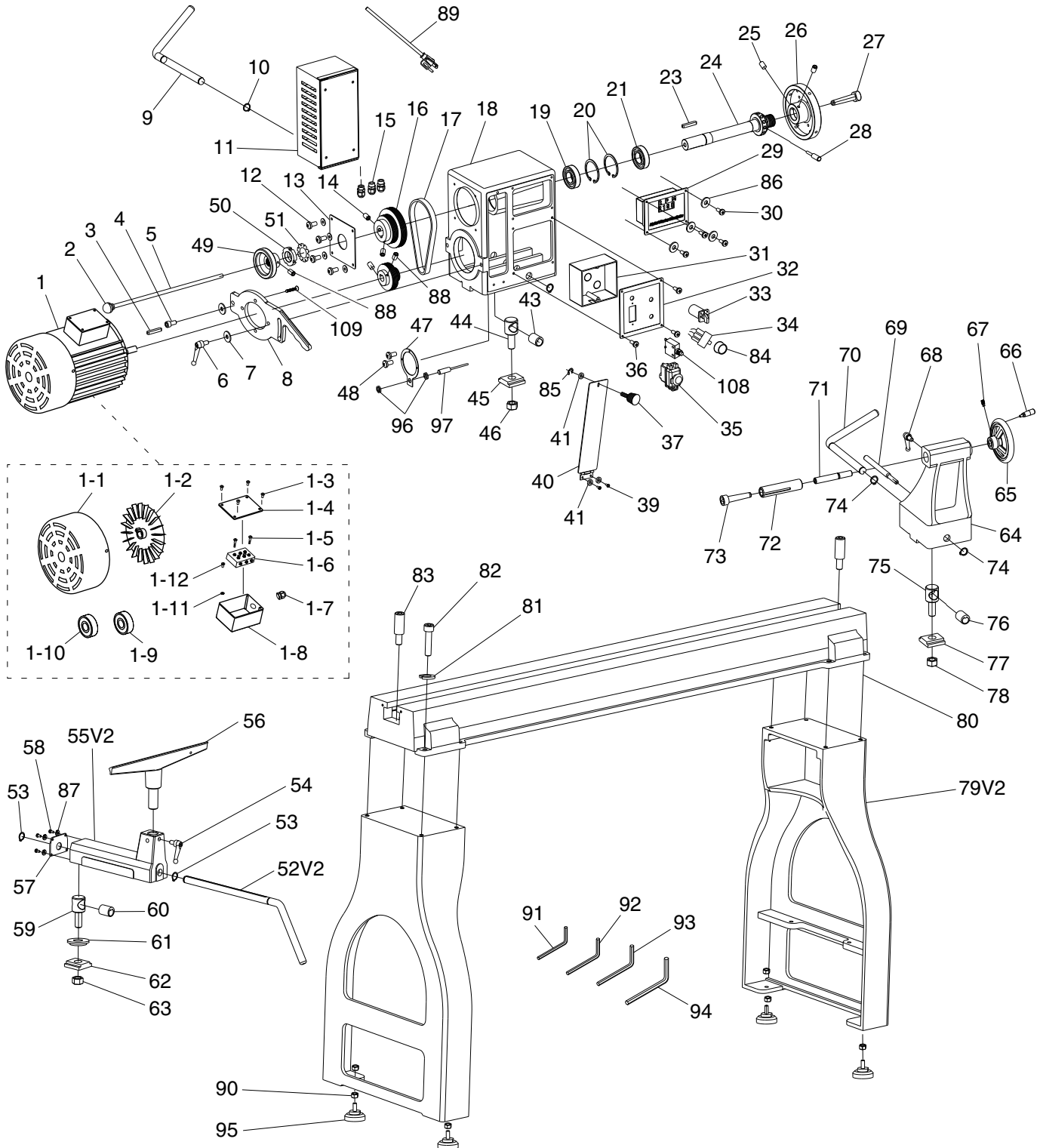

Please Note: We do our best to stock replacement parts whenever possible, but we cannot guarantee that all parts shown here are available for purchase. Call (800) 523-4777 or visit our online parts store at www.grizzly.com to check for availability.



Main Parts List

REF	PART #	DESCRIPTION
1	P0766001	MOTOR 3HP 240V 3-PH
1-1	P0766001-1	MOTOR FAN COVER
1-2	P0766001-2	MOTOR FAN
1-3	P0766001-3	TAP SCREW M4-.7 X 18
1-4	P0766001-4	MOTOR TERMINAL BOX COVER
1-5	P0766001-5	PHLP HD SCR M4-.7 X 20
1-6	P0766001-6	MOTOR TERMINAL
1-7	P0766001-7	STRAIN RELIEF PG13.5 TYPE-3
1-8	P0766001-8	MOTOR TERMINAL BOX
1-9	P0766001-9	BALL BEARING 6205ZZ (FRONT)
1-10	P0766001-10	BALL BEARING 6204ZZ (REAR)
1-11	P0766001-11	FLAT WASHER 4MM
1-12	P0766001-12	PHLP HD SCR M4-.7 X 8
2	P0766002	ROUND KNOB M8-1.25
3	P0766003	KEY 6 X 6 X 60
4	P0766004	CAP SCREW M10-1.5 X 30
5	P0766005	KNOCKOUT ROD M8-1.25 X 14, 369L
6	P0766006	BELT TENSION LOCK LEVER
7	P0766007	FENDER WASHER 10MM
8	P0766008	MOTOR PLATE
9	P0766009	HEADSTOCK LOCK LEVER
10	P0766010	EXT RETAINING RING 19MM
11	P0766011	POWER INVERTER DELTA VFD022M21A
12	P0766012	PHLP HD SCR M5-.8 X 12
13	P0766013	SPINDLE PULLEY COVER
14	P0766014	SET SCREW M8-1.25 X 10
15	P0766015	STRAIN RELIEF PG13.5 TYPE-3
16	P0766016	SPINDLE PULLEY
17	P0766017	V-BELT 220J6
18	P0766018	HEADSTOCK CASTING
19	P0766019	BALL BEARING 6206ZZ
20	P0766020	INT RETAINING RING 62MM
21	P0766021	BALL BEARING 6206ZZ
23	P0766023	KEY 8 X 8 X 45
24	P0766024	SPINDLE
25	P0766025	SET SCREW M6-1 X 12 DOG-PT
26	P0766026	FACEPLATE 153MM DIA
27	P0766027	SPUR CENTER
28	P0766028	INDEXING PIN
29	P0766029	DIGITAL READOUT
30	P0766030	PHLP HD SCR M4-.7 X 8
31	P0766031	SWITCH BOX
32	P0766032	PANEL COVER
33	P0766033	ROTARY SWITCH KEDU ZH-A FOR/OFF/REV
34	P0766034	POTENTIOMETER WX110 B10K
35	P0766035	ON/OFF SWITCH KJD178 250V 18A
36	P0766036	PHLP HD SCR M4-.7 X 6
37	P0766037	KNURLED THUMB SCREW M5-.8 X 8
39	P0766039	PHLP HD SCR M5-.8 X 8
40	P0766040	BELT DOOR
41	P0766041	FLAT WASHER 5MM
43	P0766043	BUSHING
44	P0766044	HEADSTOCK CLAMP BOLT M18-2.5 X 44
45	P0766045	HEADSTOCK CLAMP

REF	PART #	DESCRIPTION
46	P0766046	HEX NUT M18-2.5
47	P0766047	RPM SENSOR BRACKET
48	P0766048	PHLP HD SCR M4-.7 X 8
49	P0766049	HANDWHEEL 49MM DIA DISHED
50	P0766050	SPANNER NUT M30-1.5
51	P0766051	SPANNER NUT WASHER 30MM
52V2	P0766052V2	TOOL REST BASE LOCK LEVER V2.07.15
53	P0766053	EXT RETAINING RING 19MM
54	P0766054	TOOL REST LOCK LEVER
55V2	P0766055V2	TOOL REST BASE (BANJO) V2.07.15
56	P0766056	TOOL REST
57	P0766057	TOOL REST BASE PLATE
58	P0766058	PHLP HD SCR M5-.8 X 12
59	P0766059	TOOL REST CLAMP BOLT M18-2.5 X 44
60	P0766060	ECCENTRIC BUSHING
61	P0766061	TOOL REST SUPPORT BRACKET
62	P0766062	CLAMP PLATE
63	P0766063	HEX NUT M18-2.5
64	P0766064	TAILSTOCK CASTING
65	P0766065	HANDWHEEL 137MM DIA DISHED
66	P0766066	HANDWHEEL HANDLE M8-1.25 X 13, 94L
67	P0766067	SET SCREW M8-1.25 X 12
68	P0766068	QUILL LOCK LEVER
69	P0766069	STOP PIN M8-1.25 X 10, 152L
70	P0766070	TAILSTOCK LOCK LEVER
71	P0766071	LEADSCREW
72	P0766072	QUILL
73	P0766073	LIVE CENTER
74	P0766074	EXT RETAINING RING 19MM
75	P0766075	TAILSTOCK CLAMP BOLT M18-2.5 X 44
76	P0766076	ECCENTRIC BUSHING
77	P0766077	CLAMP PLATE
78	P0766078	HEX NUT M18-2.5
79V2	P0766079V2	STAND V2.07.15
80	P0766080	BED
81	P0766081	LOCK WASHER 10MM
82	P0766082	CAP SCREW M10-1.5 X 35
83	P0766083	BED STOP
84	P0766084	VARIABLE SPEED DIAL
85	P0766085	E-CLIP 5MM
86	P0766086	FLAT WASHER 4MM
87	P0766087	LOCK WASHER 5MM
88	P0766088	SET SCREW M6-1 X 10
89	P0766089	POWER CORD 14G 3W 72" 6-15P
90	P0766090	HEX NUT M10-1.5
91	P0766091	HEX WRENCH 3MM
92	P0766092	HEX WRENCH 4MM
93	P0766093	HEX WRENCH 6MM
94	P0766094	HEX WRENCH 8MM
95	P0766095	FOOT M10-1.5 X 18
96	P0766096	HEX NUT M12-1.5 THIN
97	P0766097	CONDUIT M12-1.5 X 35
108	P0766108	CIRCUIT BREAKER GEN. IND. 220V 15A
109	P0766109	FLAT HD CAP SCR M8-1.25 X 20



Labels

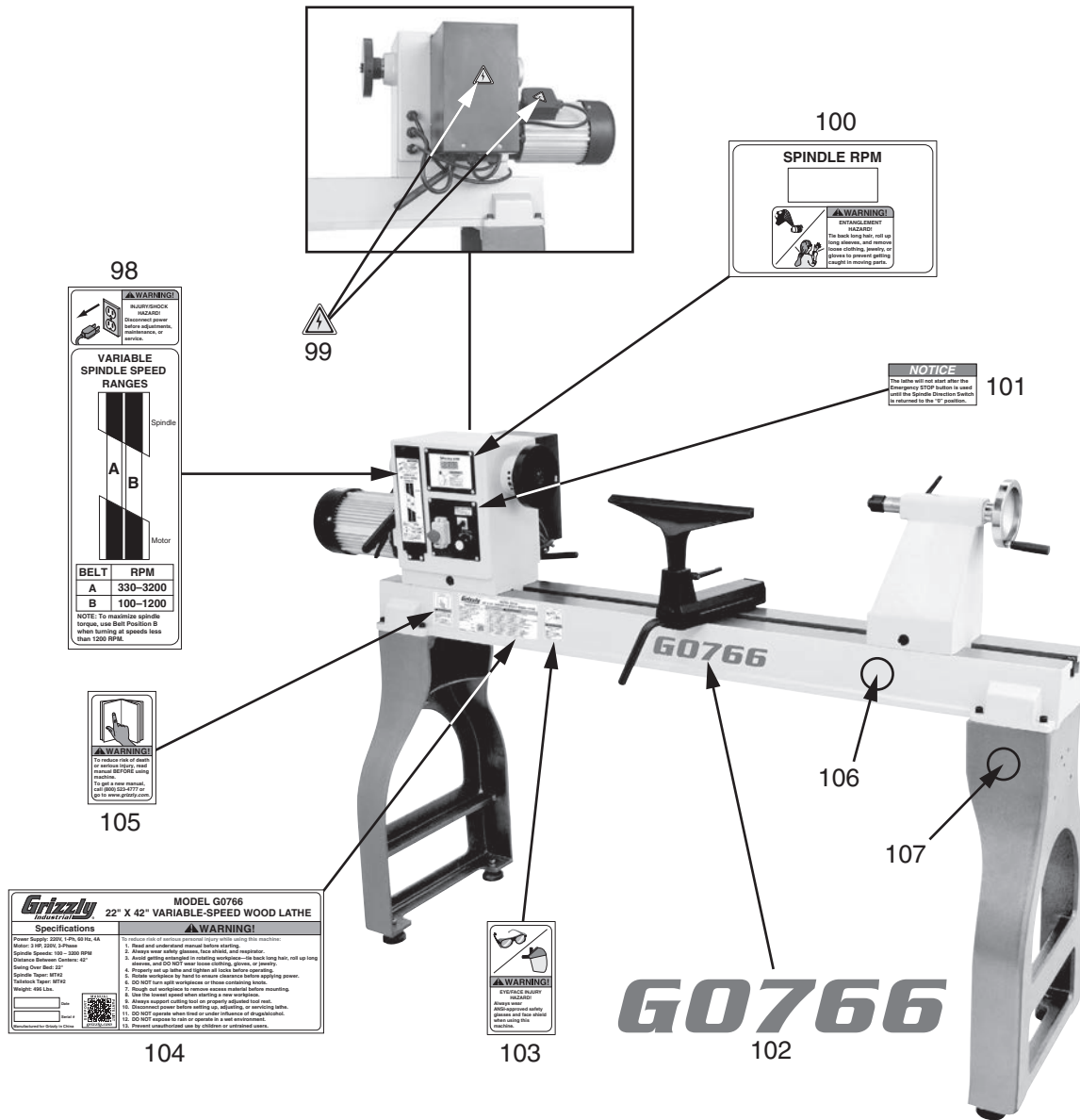

REF	PART #	DESCRIPTION
98	P0766098	SPINDLE SPEED CHART
99	P0766099	ELECTRICITY LABEL
100	P0766100	SPINDLE RPM LABEL
101	P0766101	SPINDLE DIRECTION SWITCH NOTICE
102	P0766102	MODEL NUMBER LABEL

REF	PART #	DESCRIPTION
103	P0766103	EYE/FACE INJURY HAZARD LABEL
104	P0766104	MACHINE ID LABEL
105	P0766105	READ MANUAL LABEL
106	P0766106	BEIGE TOUCH-UP PAINT
107	P0766107	GRIZZLY GREEN TOUCH-UP PAINT

WARNING

Safety labels help reduce the risk of serious injury caused by machine hazards. If any label comes off or becomes unreadable, the owner of this machine **MUST** replace it in the original location before resuming operations. For replacements, contact (800) 523-4777 or www.grizzly.com.





WARRANTY CARD

Name _____
 Street _____
 City _____ State _____ Zip _____
 Phone # _____ Email _____
 Model # _____ Order # _____ Serial # _____

The following information is given on a voluntary basis. It will be used for marketing purposes to help us develop better products and services. **Of course, all information is strictly confidential.**

1. How did you learn about us?

<input type="checkbox"/> Advertisement	<input type="checkbox"/> Friend	<input type="checkbox"/> Catalog
<input type="checkbox"/> Card Deck	<input type="checkbox"/> Website	<input type="checkbox"/> Other: _____

2. Which of the following magazines do you subscribe to?

<input type="checkbox"/> Cabinetmaker & FDM	<input type="checkbox"/> Popular Science	<input type="checkbox"/> Wooden Boat
<input type="checkbox"/> Family Handyman	<input type="checkbox"/> Popular Woodworking	<input type="checkbox"/> Woodshop News
<input type="checkbox"/> Hand Loader	<input type="checkbox"/> Precision Shooter	<input type="checkbox"/> Woodsmith
<input type="checkbox"/> Handy	<input type="checkbox"/> Projects in Metal	<input type="checkbox"/> Woodwork
<input type="checkbox"/> Home Shop Machinist	<input type="checkbox"/> RC Modeler	<input type="checkbox"/> Woodworker West
<input type="checkbox"/> Journal of Light Cont.	<input type="checkbox"/> Rifle	<input type="checkbox"/> Woodworker's Journal
<input type="checkbox"/> Live Steam	<input type="checkbox"/> Shop Notes	<input type="checkbox"/> Other: _____
<input type="checkbox"/> Model Airplane News	<input type="checkbox"/> Shotgun News	
<input type="checkbox"/> Old House Journal	<input type="checkbox"/> Today's Homeowner	
<input type="checkbox"/> Popular Mechanics	<input type="checkbox"/> Wood	

3. What is your annual household income?

<input type="checkbox"/> \$20,000-\$29,000	<input type="checkbox"/> \$30,000-\$39,000	<input type="checkbox"/> \$40,000-\$49,000
<input type="checkbox"/> \$50,000-\$59,000	<input type="checkbox"/> \$60,000-\$69,000	<input type="checkbox"/> \$70,000+

4. What is your age group?

<input type="checkbox"/> 20-29	<input type="checkbox"/> 30-39	<input type="checkbox"/> 40-49
<input type="checkbox"/> 50-59	<input type="checkbox"/> 60-69	<input type="checkbox"/> 70+

5. How long have you been a woodworker/metalworker?

<input type="checkbox"/> 0-2 Years	<input type="checkbox"/> 2-8 Years	<input type="checkbox"/> 8-20 Years	<input type="checkbox"/> 20+ Years
------------------------------------	------------------------------------	-------------------------------------	------------------------------------

6. How many of your machines or tools are Grizzly?

<input type="checkbox"/> 0-2	<input type="checkbox"/> 3-5	<input type="checkbox"/> 6-9	<input type="checkbox"/> 10+
------------------------------	------------------------------	------------------------------	------------------------------

7. Do you think your machine represents a good value? Yes No
8. Would you recommend Grizzly Industrial to a friend? Yes No
9. Would you allow us to use your name as a reference for Grizzly customers in your area?
Note: We never use names more than 3 times. Yes No

10. Comments: _____

CUT ALONG DOTTED LINE

FOLD ALONG DOTTED LINE



Place Stamp Here



GRIZZLY INDUSTRIAL, INC.
P.O. BOX 2069
BELLINGHAM, WA 98227-2069



FOLD ALONG DOTTED LINE

Send a Grizzly Catalog to a friend:

Name _____
Street _____
City _____ State _____ Zip _____

TAPE ALONG EDGES--PLEASE DO NOT STAPLE

WARRANTY & RETURNS

Grizzly Industrial, Inc. warrants every product it sells for a period of **1 year** to the original purchaser from the date of purchase. This warranty does not apply to defects due directly or indirectly to misuse, abuse, negligence, accidents, repairs or alterations or lack of maintenance. This is Grizzly's sole written warranty and any and all warranties that may be implied by law, including any merchantability or fitness, for any particular purpose, are hereby limited to the duration of this written warranty. We do not warrant or represent that the merchandise complies with the provisions of any law or acts unless the manufacturer so warrants. In no event shall Grizzly's liability under this warranty exceed the purchase price paid for the product and any legal actions brought against Grizzly shall be tried in the State of Washington, County of Whatcom.

We shall in no event be liable for death, injuries to persons or property or for incidental, contingent, special, or consequential damages arising from the use of our products.

To take advantage of this warranty, contact us by mail or phone and give us all the details. We will then issue you a "Return Number," which must be clearly posted on the outside as well as the inside of the carton. We will not accept any item back without this number. Proof of purchase must accompany the merchandise.

The manufacturers reserve the right to change specifications at any time because they constantly strive to achieve better quality equipment. We make every effort to ensure that our products meet high quality and durability standards and we hope you never need to use this warranty.

Please feel free to write or call us if you have any questions about the machine or the manual.

Thank you again for your business and continued support. We hope to serve you again soon.

grizzly.com[®]

TOOL WEBSITE

Buy Direct and Save with Grizzly[®] – Trusted, Proven and a Great Value!
~Since 1983~

*Visit Our Website Today For
Current Specials!*

**ORDER
24 HOURS A DAY!
1-800-523-4777**



Free Manuals Download Website

<http://myh66.com>

<http://usermanuals.us>

<http://www.somanuals.com>

<http://www.4manuals.cc>

<http://www.manual-lib.com>

<http://www.404manual.com>

<http://www.luxmanual.com>

<http://aubethermostatmanual.com>

Golf course search by state

<http://golfingnear.com>

Email search by domain

<http://emailbydomain.com>

Auto manuals search

<http://auto.somanuals.com>

TV manuals search

<http://tv.somanuals.com>