

Grizzly *Industrial, Inc.*®

MODEL T24463/T24464 6" BENCH GRINDERS OWNER'S MANUAL

(For models manufactured since 01/12)



Model T24463



Model T24464

COPYRIGHT © MAY, 2012 BY GRIZZLY INDUSTRIAL, INC.
**WARNING: NO PORTION OF THIS MANUAL MAY BE REPRODUCED IN ANY SHAPE
OR FORM WITHOUT THE WRITTEN APPROVAL OF GRIZZLY INDUSTRIAL, INC.**
#KN14983 PRINTED IN CHINA

 **WARNING!**

This manual provides critical safety instructions on the proper setup, operation, maintenance, and service of this machine/tool. Save this document, refer to it often, and use it to instruct other operators.

Failure to read, understand and follow the instructions in this manual may result in fire or serious personal injury—including amputation, electrocution, or death.

The owner of this machine/tool is solely responsible for its safe use. This responsibility includes but is not limited to proper installation in a safe environment, personnel training and usage authorization, proper inspection and maintenance, manual availability and comprehension, application of safety devices, cutting/sanding/grinding tool integrity, and the usage of personal protective equipment.

The manufacturer will not be held liable for injury or property damage from negligence, improper training, machine modifications or misuse.

 **WARNING!**

Some dust created by power sanding, sawing, grinding, drilling, and other construction activities contains chemicals known to the State of California to cause cancer, birth defects or other reproductive harm. Some examples of these chemicals are:

- **Lead from lead-based paints.**
- **Crystalline silica from bricks, cement and other masonry products.**
- **Arsenic and chromium from chemically-treated lumber.**

Your risk from these exposures varies, depending on how often you do this type of work. To reduce your exposure to these chemicals: Work in a well ventilated area, and work with approved safety equipment, such as those dust masks that are specially designed to filter out microscopic particles.

Table of Contents

INTRODUCTION	2	SECTION 4: OPERATIONS	16
Manual Accuracy	2	Operation Overview	16
Contact Info.....	2	Wheel Selection	17
Machine Description	2	Wheel Inspection	18
Identification.....	3	Wheel Dressing.....	18
Machine Data Sheet	4	Wheel Removal & Installation.....	19
SECTION 1: SAFETY	5	SECTION 5: ACCESSORIES	20
Safety Instructions for Machinery	5	SECTION 6: MAINTENANCE	21
Additional Safety Instructions for Grinders	7	Schedule	21
SECTION 2: POWER SUPPLY	8	Grinding Wheels	21
Availability.....	8	Wheel Dressing.....	21
Full-Load Current Rating	8	SECTION 7: SERVICE	22
Circuit Requirements	8	Troubleshooting	22
Grounding & Plug Requirements.....	9	Motor & Electrical	22
Extension Cords	9	SECTION 8: WIRING	23
SECTION 3: SETUP	10	Wiring Safety Instructions	23
Needed for Setup.....	10	T24463 Wiring.....	24
Unpacking	10	T24464 Wiring.....	25
Inventory	11	SECTION 9: PARTS	26
Model T24463 Inventory.....	11	T24463 Breakdown.....	26
Model T24464 Inventory.....	11	T24463 Parts List.....	27
Site Considerations.....	12	T24464 Breakdown.....	28
Weight Load	12	T24464 Parts List.....	29
Space Allocation.....	12	T24463/T24464 Labels	30
Physical Environment.....	12	WARRANTY & RETURNS	33
Electrical Installation.....	12		
Lighting	12		
Mounting	13		
Through Mount with Rubber Feet	13		
Through Mounting	13		
Surface Mounting	13		
Assembly	14		
Spark Deflector Adjustment.....	14		
Tool Rest Adjustment	14		
Power Connection.....	15		
Connecting Power	15		
Disconnecting Power.....	15		
Test Run	15		

INTRODUCTION

Manual Accuracy

We are proud to offer this manual with your new machine! We've made every effort to be exact with the instructions, specifications, drawings, and photographs of the machine we used when writing this manual. However, sometimes we still make an occasional mistake.

Also, owing to our policy of continuous improvement, **your machine may not exactly match the manual**. If you find this to be the case, and the difference between the manual and machine leaves you in doubt, check our website for the latest manual update or call technical support for help.

Before calling, find the manufacture date of your machine by looking at the date stamped into the machine ID label (see below). This will help us determine if the manual version you received matches the manufacture date of your machine.

		MODEL GXXXX MACHINE NAME	
SPECIFICATIONS		WARNING!	
Motor:		Manufacture Date of Your Machine When using this machine: operation. Use safety glasses and respirator. Read and understand the manual before starting. 4. make sure the motor has stopped and disconnect power before adjustments, maintenance, or service. 5. DO NOT expose to rain or dampness. 6. DO NOT modify this machine in any way. 7. DO NOT remove safety guards. 8. Never leave machine running unattended. 9. DO NOT operate under the influence of drugs or alcohol. 10. Maintain machine carefully to prevent accidents.	
Specification:			
Specification:			
Specification:			
Weight:			
<input type="text"/>	Date		
<input type="text"/>	Serial Number		
Manufactured for Grizzly in Taiwan			

For your convenience, we post all available manuals and manual updates for free on our website at www.grizzly.com. Any updates to your model of machine will be reflected in these documents as soon as they are complete.

Contact Info

We stand behind our machines. If you have any questions or need help, use the information below to contact us. Before contacting, please get the serial number and manufacture date of your machine. This will help us help you faster.

Grizzly Technical Support
1203 Lycoming Mall Circle
Muncy, PA 17756
Phone: (570) 546-9663
Email: techsupport@grizzly.com

We want your feedback on this manual. What did you like about it? Where could it be improved? Please take a few minutes to give us feedback.

Grizzly Documentation Manager
P.O. Box 2069
Bellingham, WA 98227-2069
Email: manuals@grizzly.com

Machine Description

The Model T24463 6" Bench Grinder is a great grinder for the hobbyist or small shop. Model T24463 gives the user a lot of options with features like a wire wheel, a grinding wheel, wheel dressing tool, worklight, and coolant tray.

Model T24464 is a dedicated grinder with two wheel grits included on the machine. Its straightforward, compact design will make it an indispensable machine for your shop.

Identification

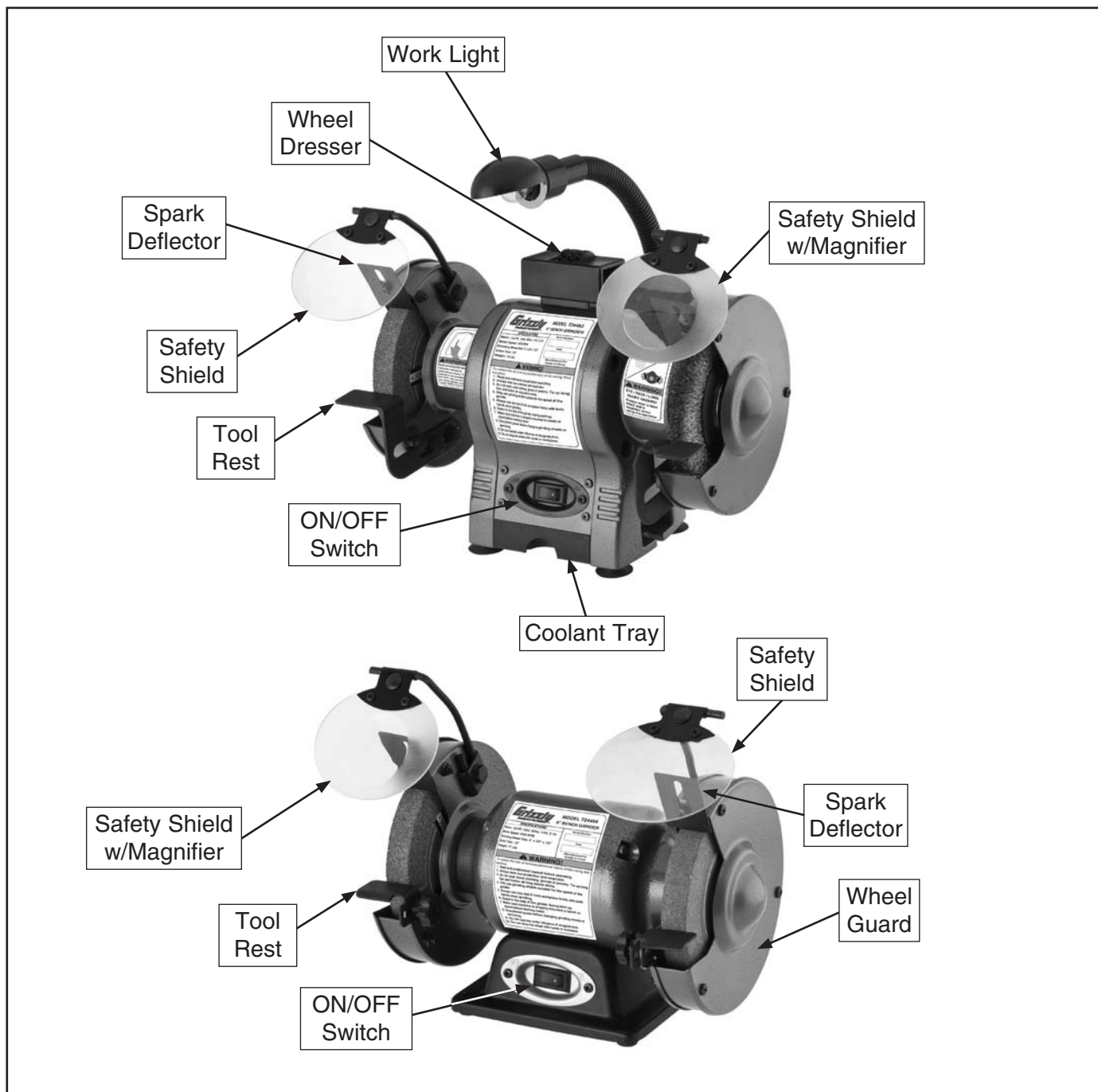
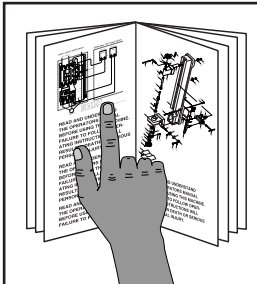

Figure 2. Machine identification.

	<p>!WARNING To reduce the risk of serious injury when using this machine, read and understand this entire manual before beginning any operations.</p>
---	--





MACHINE DATA SHEET

© Grizzly Industrial, Inc. • Customer Service: (800) 523-4777 • Tech Support: (570) 546-9663

MODEL T24463, T24464 6" Bench Grinders

Model Number	T24463	T24464
Product Dimensions		
Weight	19 lbs.	17 lbs.
Width (side-to-side)/Depth (front-to-back)/Height	7½" x 13¾" x 9"	8¼" x 14¾" x 10¼"
Foot Print (Width/Depth)	5" x 24"	5½" x 4¾"
Shipping Dimensions		
Type	Cardboard	
Weight	21 lbs.	19 lbs.
Width (side-to-side)/Depth (front-to-back)/Height	11" x 17" x 12"	10" x 14" x 10"
Electrical		
Power Requirement	120V, Single-Phase, 60 Hz	
Switch Voltage	120V	
Cord Length	6½ ft.	
Cord Gauge	16AWG	
Minimum Circuit Size	15 Amp	
Included Plug Type	NEMA 5-15	
Main		
Spindle Diameter	½"	
Grinding Wheel Grit	36	36/60
Grinding Wheel Size (Diameter x Width x Bore)	6" x ¾" x ½"	
Grinding Wheel Material	Aluminum Oxide	
Wheel Speed	3450 RPM	
Motor		
Type	TEFC Capacitor Start Induction	
Horsepower	⅓ HP	
Amps	2.1A	
Phase	Single	
Voltage	120V	
Cycle	60 Hz	
Speed	3450 RPM	
Other		
Country of Origin	China	
Warranty	1 Year	



SECTION 1: SAFETY

WARNING

For Your Own Safety, Read Instruction Manual Before Operating this Machine

The purpose of safety symbols is to attract your attention to possible hazardous conditions. This manual uses a series of symbols and signal words intended to convey the level of importance of the safety messages. The progression of symbols is described below. Remember that safety messages by themselves do not eliminate danger and are not a substitute for proper accident prevention measures.

 **DANGER** Indicates an imminently hazardous situation which, if not avoided, **WILL** result in death or serious injury.

 **WARNING** Indicates a potentially hazardous situation which, if not avoided, **COULD** result in death or serious injury.

 **CAUTION** Indicates a potentially hazardous situation which, if not avoided, **MAY** result in minor or moderate injury. It may also be used to alert against unsafe practices.

NOTICE This symbol is used to alert the user to useful information about proper operation of the machine.

WARNING

Safety Instructions for Machinery

OWNER'S MANUAL. Read and understand this owner's manual **BEFORE** using machine. Untrained users can be seriously hurt.

EYE PROTECTION. Always wear ANSI-approved safety glasses or a face shield when operating or observing machinery to reduce the risk of eye injury or blindness from flying particles. Everyday eyeglasses are not approved safety glasses.

HAZARDOUS DUST. Dust created while using machinery may cause cancer, birth defects, or long-term respiratory damage. Be aware of dust hazards associated with each workpiece material, and always wear a NIOSH-approved respirator to reduce your risk.

WEARING PROPER APPAREL. Do not wear clothing, apparel, or jewelry that can become entangled in moving parts. Always tie back or cover long hair. Wear non-slip footwear to avoid accidental slips which could cause a loss of workpiece control.

HEARING PROTECTION. Always wear hearing protection when operating or observing loud machinery. Extended exposure to this noise without hearing protection can cause permanent hearing loss.

MENTAL ALERTNESS. Be mentally alert when running machinery. Never operate under the influence of drugs or alcohol, when tired, or when distracted.



WARNING

DISCONNECTING POWER SUPPLY. Always disconnect machine from power supply before servicing, adjusting, or changing cutting tools (bits, blades, cutters, etc.). Make sure switch is in OFF position before reconnecting to avoid an unexpected or unintentional start.

APPROVED OPERATION. Untrained operators can be seriously hurt by machinery. Only allow trained or properly supervised people to use machine. When machine is not being used, disconnect power, remove switch keys, or lock-out machine to prevent unauthorized use—especially around children. Make workshop kid proof!

DANGEROUS ENVIRONMENTS. Do not use machinery in wet or rainy locations, cluttered areas, around flammables, or in dark areas. Keep work area clean, dry, and well-lighted.

ONLY USE AS INTENDED. Only use machine for its intended purpose. Never modify machine for a purpose not intended by the manufacturer!

USE RECOMMENDED ACCESSORIES. Consult this owner's manual or the manufacturer for recommended accessories. Using improper accessories will increase the risk of serious injury.

CHILDREN & BYSTANDERS. Keep children and bystanders a safe distance away from work area. Stop using machine if children or bystanders become a distraction.

REMOVE ADJUSTING TOOLS. Never leave adjustment tools, chuck keys, wrenches, etc. in or on machine—especially near moving parts. Verify removal before starting!

SECURING WORKPIECE. When required, use clamps or vises to secure workpiece. A secured workpiece protects hands and frees both of them to operate the machine.

FEED DIRECTION. Unless otherwise noted, feed work against the rotation of blades or cutters. Feeding in the same direction of rotation may pull your hand into the cut.

FORCING MACHINERY. Do not force machine. It will do the job safer and better at the rate for which it was designed.

GUARDS & COVERS. Guards and covers can protect you from accidental contact with moving parts or flying debris. Make sure they are properly installed, undamaged, and working correctly before using machine.

NEVER STAND ON MACHINE. Serious injury or accidental contact with cutting tool may occur if machine is tipped. Machine may be damaged.

STABLE MACHINE. Unexpected movement during operations greatly increases risk of injury or loss of control. Before starting, verify machines are stable and mobile base (if used) is locked.

AWKWARD POSITIONS. Keep proper footing and balance at all times when operating machine. Do not overreach! Avoid awkward hand positions that make workpiece control difficult or increase the risk of accidental injury.

UNATTENDED OPERATION. Never leave machine running while unattended. Turn machine **OFF** and ensure all moving parts completely stop before walking away.

MAINTAIN WITH CARE. Follow all maintenance instructions and lubrication schedules to keep machine in good working condition. An improperly maintained machine increases risk of injury.

CHECK DAMAGED PARTS. Regularly inspect machine for damaged parts, loose bolts, mis-adjusted or mis-aligned parts, binding, or any other conditions that may affect safe operation. Always repair or replace damaged or mis-adjusted parts before operating machine.

MAINTAIN POWER CORDS. When disconnecting cord-connected machines from power, grab and pull the plug—NOT the cord. Pulling the cord may damage the wires inside. Do not handle cord/plug with wet hands. Avoid cord damage by keeping it away from heated surfaces, high traffic areas, harsh chemicals, and wet/damp locations.

EXPERIENCING DIFFICULTIES. If at any time you are experiencing difficulties performing the intended operation, stop using the machine! Contact our Technical Support Department at (570) 546-9663.



WARNING

Additional Safety Instructions for Grinders

SAFE MOUNTING & WORK AREA. An unsecured grinder may become dangerously out of control during operation. Before use, verify the grinder is **FIRMLY** secured, and that no explosive or flammable materials are nearby.

RING TEST. Perform a "ring test" on grinding wheels before installation to ensure that they are safe to use. A wheel that does not pass the ring test may break or fly apart during operation.

WHEEL SPEED RATING. Wheels operated at a faster speed than rated for may break or burst. Before mounting a new wheel, be sure the wheel RPM rating is equal or higher than the speed of the grinder. Never use unmarked wheels.

SPARK DEFLECTOR. Keep the gap between the end of the spark deflector and the grinding wheel between $\frac{1}{8}$ " and $\frac{1}{4}$ ". If the gap is larger, excessive sparks and abrasives can be expelled toward the operator.

TOOL REST. If the tool rest is too far away from the wheel, the workpiece may be pulled down, causing loss of control and pulling your hand into the grinding wheel. Keep the tool rest within $\frac{1}{8}$ " from the wheel when operating. Replace the grinding wheel when the tool rest gap is wider than $\frac{1}{8}$ " and no additional adjustment can be made.

WHEEL FLANGES. Only use the flanges included with the grinder when mounting wheels. Other flanges may not properly secure the wheel and cause an accident.

EYE, FACE, & LUNG PROTECTION. Grinding ejects small particles at a high rate of speed. These particles can cause blindness, skin injuries or respiratory damage. **ALWAYS** wear approved clothing, safety goggles, face shield, and a respirator for the type of grinding to be done.

SIDE & TOP GRINDING. Grinding on the side of wheels can cause the them to crack and burst—unless the wheel is rated for side grinding. Grinding on the top of wheels greatly increases the risk of workpiece kickback. Always grind on the downward part of the wheel.

HAND & WHEEL CONTACT. Keep a firm grip on the workpiece and position your hands a safe distance away when grinding. Anticipate when the workpiece will heat up, and cool it before it becomes too hot to hold, or use an appropriate clamp. Avoid wearing gloves as they may get caught in the grinding wheel and cause even more serious entanglement injuries.

STARTING GRINDER. If a wheel is damaged, it will usually fly apart shortly after start-up. To protect yourself, always stand to the side of the grinder when turning it **ON** and allow it to run a full minute before standing in front of it.

WARNING

Like all machinery there is potential danger when operating this bench grinder. Accidents are frequently caused by lack of familiarity or failure to pay attention. Use this bench grinder with respect and caution to lessen the possibility of operator injury. If normal safety precautions are overlooked or ignored, serious personal injury may occur.

CAUTION

No list of safety guidelines can be complete. Every shop environment is different. Always consider safety first, as it applies to your individual working conditions. Use this and other machinery with caution and respect. Failure to do so could result in serious personal injury, damage to equipment, or poor work results.



SECTION 2: POWER SUPPLY

Availability

Before installing the machine, consider the availability and proximity of the required power supply circuit. If an existing circuit does not meet the requirements for this machine, a new circuit must be installed. To minimize the risk of electrocution, fire, or equipment damage, installation work and electrical wiring must be done by a qualified electrician in accordance with all applicable codes and standards.

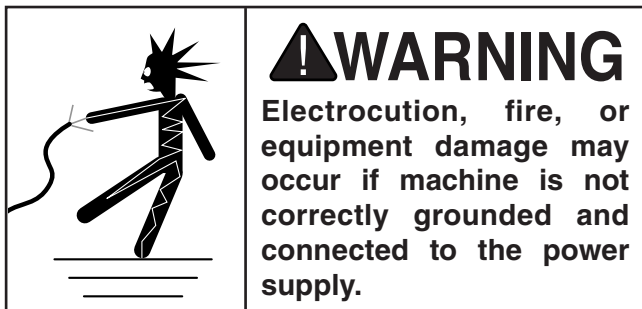

Full-Load Current Rating

The full-load current rating is the amperage a machine draws at 100% of the rated output power. On machines with multiple motors, this is the amperage drawn by the largest motor or sum of all motors and electrical devices that might operate at one time during normal operations.

Full-Load Current Rating at 120V 2.1 Amps

The full-load current is not the maximum amount of amps that the machine will draw. If the machine is overloaded, it will draw additional amps beyond the full-load rating.

If the machine is overloaded for a sufficient length of time, damage, overheating, or fire may result—especially if connected to an undersized circuit. To reduce the risk of these hazards, avoid overloading the machine during operation and make sure it is connected to a power supply circuit that meets the requirements in the following section.

! WARNING

Serious injury could occur if you connect the machine to power before completing the setup process. DO NOT connect to power until instructed later in this manual.

Circuit Requirements

This machine is prewired to operate on a 120V power supply circuit that has a verified ground and meets the following requirements:

Nominal Voltage 120V
Cycle 60 Hz
Phase Single-Phase
Power Supply Circuit 15 Amps

A power supply circuit includes all electrical equipment between the breaker box or fuse panel in the building and the machine. The power supply circuit used for this machine must be sized to safely handle the full-load current drawn from the machine for an extended period of time. (If this machine is connected to a circuit protected by fuses, use a time delay fuse marked D.)

! CAUTION

For your own safety and protection of property, consult an electrician if you are unsure about wiring practices or electrical codes in your area.

Note: *The circuit requirements listed in this manual apply to a dedicated circuit—where only one machine will be running at a time. If this machine will be connected to a shared circuit where multiple machines will be running at the same time, consult a qualified electrician to ensure that the circuit is properly sized for safe operation.*



Grounding & Plug Requirements

This machine **MUST** be grounded. In the event of certain malfunctions or breakdowns, grounding reduces the risk of electric shock by providing a path of least resistance for electric current.

This machine is equipped with a power cord that has an equipment-grounding wire and a grounding plug (similar to the figure below). The plug must only be inserted into a matching receptacle (outlet) that is properly installed and grounded in accordance with all local codes and ordinances.

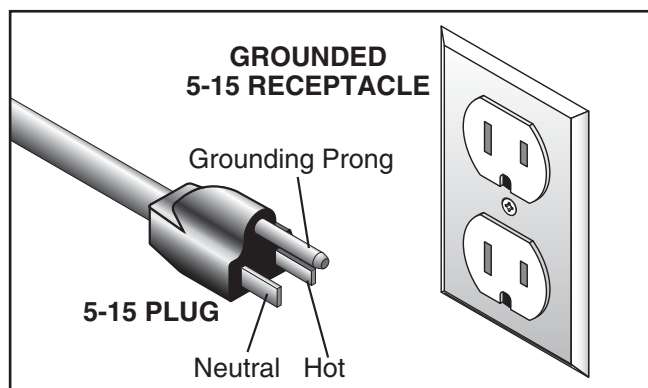

Figure 3. Typical 5-15 plug and receptacle.

⚠ CAUTION

SHOCK HAZARD!
Two-prong outlets do not meet the grounding requirements for this machine. Do not modify or use an adapter on the plug provided—if it will not fit the outlet, have a qualified electrician install the proper outlet with a verified ground.

Improper connection of the equipment-grounding wire can result in a risk of electric shock. The wire with green insulation (with or without yellow stripes) is the equipment-grounding wire. If repair or replacement of the power cord or plug is necessary, do not connect the equipment-grounding wire to a live (current carrying) terminal.

Check with a qualified electrician or service personnel if you do not understand these grounding requirements, or if you are in doubt about whether the tool is properly grounded. If you ever notice that a cord or plug is damaged or worn, disconnect it from power, and immediately replace it with a new one.

Extension Cords

We do not recommend using an extension cord with this machine. If you must use an extension cord, only use it if absolutely necessary and only on a temporary basis.

Extension cords cause voltage drop, which may damage electrical components and shorten motor life. Voltage drop increases as the extension cord size gets longer and the gauge size gets smaller (higher gauge numbers indicate smaller sizes).

Any extension cord used with this machine must contain a ground wire, match the required plug and receptacle, and meet the following requirements:

Minimum Gauge Size16 AWG
Maximum Length (Shorter is Better).....50 ft.



SECTION 3: SETUP

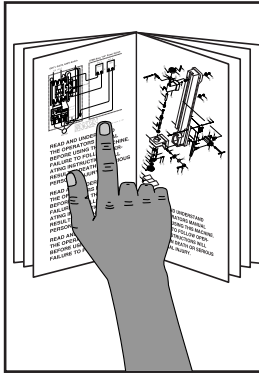

!WARNING

This machine presents serious injury hazards to untrained users. Read through this entire manual to become familiar with the controls and operations before starting the machine!

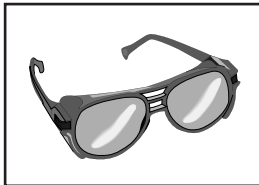

!WARNING

Wear safety glasses during the entire setup process!

Needed for Setup

The following are needed to complete the setup process, but are not included with your machine.

Description	Qty
• Safety Glasses	1
• Wrench 8mm	1
• Wrench 14mm	1
• Phillips Screwdriver #2	1
• 3/8" Mounting Fasteners	2

Unpacking

Your machine was carefully packaged for safe transportation. Remove the packaging materials from around your machine and inspect it. If you discover any damage, *please call us immediately at (570) 546-9663 for advice.*

Save the containers and all packing materials for possible inspection by the carrier or its agent. *Otherwise, filing a freight claim can be difficult.*

When you are completely satisfied with the condition of your shipment, inventory the contents.



!WARNING

SUFFOCATION HAZARD!

Keep children and pets away from plastic bags or packing materials shipped with this machine. Discard immediately.



Inventory

The following is a description of the main components shipped with your machine. Lay the components out to inventory them.

If any non-proprietary parts are missing (e.g. a nut or a washer), we will gladly replace them; or for the sake of expediency, replacements can be obtained at your local hardware store.

Model T24463 Inventory

Box 1: (Figure 4)	Qty
A. Bench Grinder w/Grinding and Brush Wheel (Not Shown).....	1
B. Safety Shield Brackets	2
C. Safety Shield w/Magnifier.....	1
D. Safety Shield	1
E. Safety Shield Arms (Right and Left).....	1 Ea.
F. Spark Deflectors.....	2
G. Tool Rests (Right and Left).....	1 Ea.
H. Arm Brackets.....	2
I. Wheel Dresser.....	1
J. Hardware (Not Shown)	
—Hex Bolt M8-1.25 x 14	2
—Hex Bolt M8-1.25 x 10	4
—Flat Washer 8mm	6
—Phillips Head Screws M5-.8 x 10.....	2
—Lock Washer 5mm.....	2
—Flat Washer 5mm	2

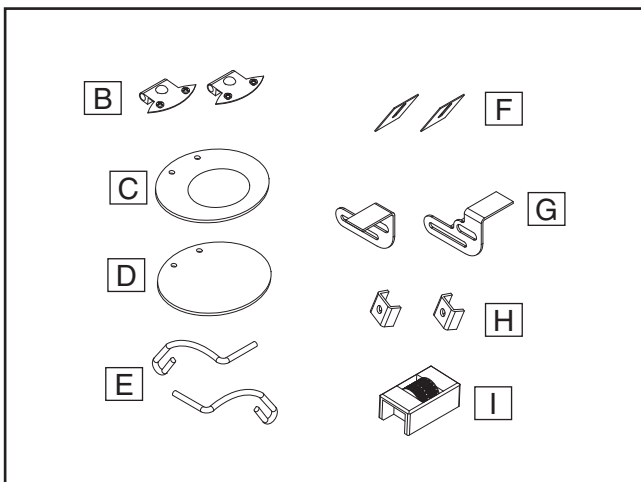

Figure 4. Model T24463 inventory.

Model T24464 Inventory

Box 1: (Figure 5)	Qty
A. Bench Grinder w/Grinding Wheels (Not Shown)	1
B. Safety Shield Brackets	2
C. Safety Shield w/ Magnifier.....	1
D. Safety Shield	1
E. Safety Shield Arms (Right and Left).....	1 Ea.
F. Spark Deflectors.....	2
G. Tool Rests (Right and Left).....	1 Ea.
H. Tool Rest Knobs M6-1	2
I. Arm Brackets.....	2
J. Hardware (Not Shown)	
—Phillips Head Screws M5-.8 x 10.....	2
—Lock Washer 5mm.....	2
—Flat Washer 5mm	2
—Carriage Bolt M6-1 x 14.....	2
—Hex Bolt M8-1.25 x 14	2
—Flat Washer 8mm	2

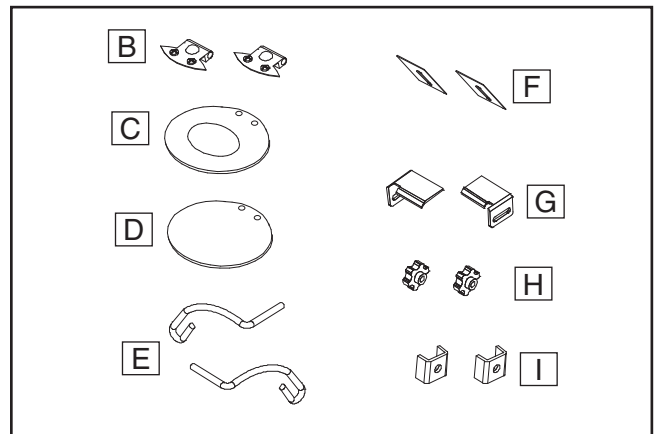

Figure 5. Model T24464 inventory.

NOTICE

If you cannot find an item on this list, carefully check the machine and the packaging materials. Some of these items may be pre-installed for shipping or become misplaced during unpacking.



Site Considerations

Weight Load

Refer to the **Machine Data Sheet** for the weight of your machine. Make sure that the surface upon which the machine is placed will bear the weight of the machine, additional equipment that may be installed on the machine, and the heaviest workpiece that will be used. Additionally, consider the weight of the operator and any dynamic loading that may occur when operating the machine.

Space Allocation

Consider the largest size of workpiece that will be processed through this machine and provide enough space around the machine for adequate operator material handling or the installation of auxiliary equipment. With permanent installations, leave enough space around the machine to open or remove doors/covers as required by the maintenance and service described in this manual. **See below for required space allocation.**

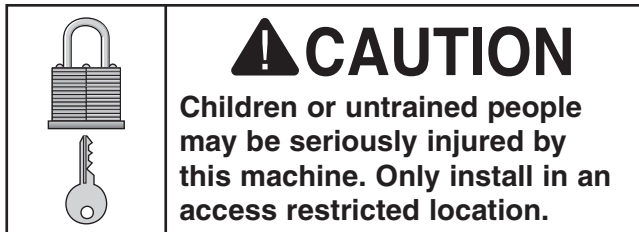

Physical Environment

The physical environment where the machine is operated is important for safe operation and longevity of machine components. For best results, operate this machine in a dry environment that is free from excessive moisture, hazardous chemicals, airborne abrasives, or extreme conditions. Extreme conditions for this type of machinery are generally those where the ambient temperature range exceeds 41°–104°F; the relative humidity range exceeds 20–95% (non-condensing); or the environment is subject to vibration, shocks, or bumps.

Electrical Installation

Place this machine near an existing power source. Make sure all power cords are protected from traffic, material handling, moisture, chemicals, or other hazards. Make sure to leave access to a means of disconnecting the power source or engaging a lockout/tagout device, if required.

Lighting

Lighting around the machine must be adequate enough that operations can be performed safely. Shadows, glare, or strobe effects that may distract or impede the operator must be eliminated.

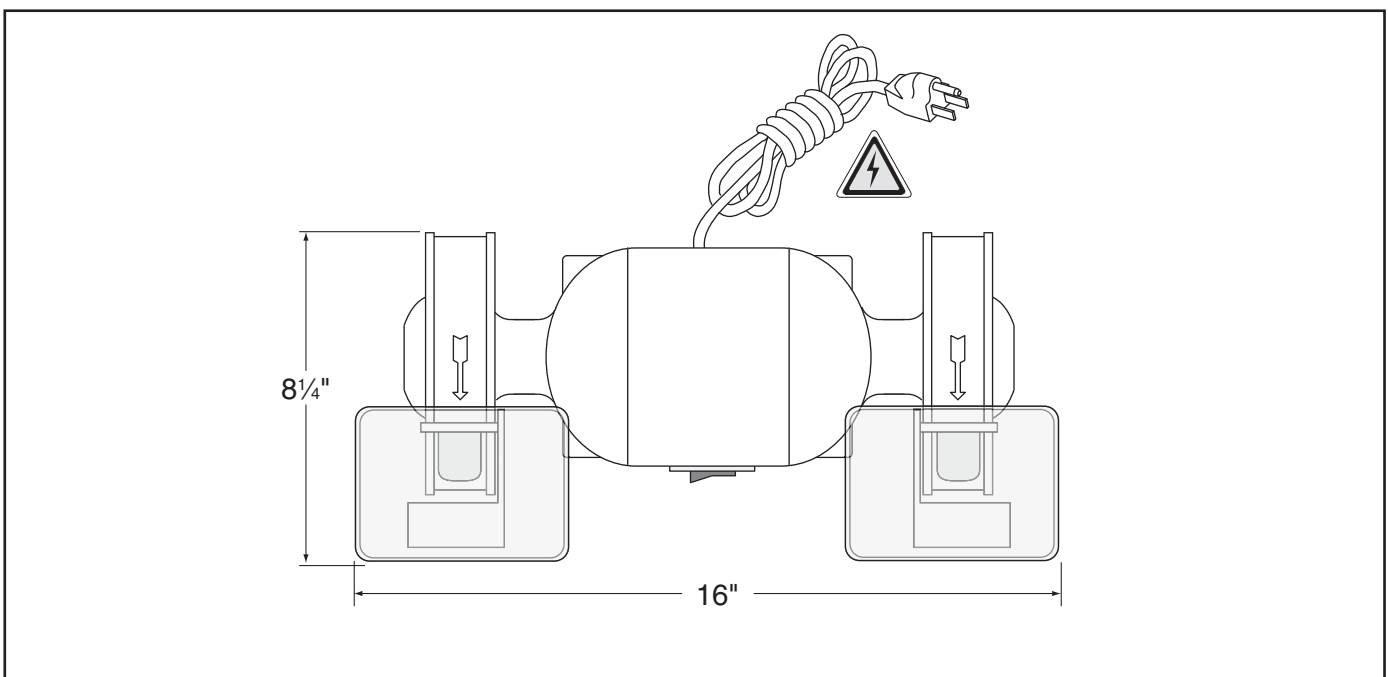

Figure 6. Minimum working clearances.



Mounting

The grinder must be mounted to a solid surface to prevent unexpected movement during operation that could result in injury or property damage. Below are three of the most common options for mounting grinders.

Through Mount with Rubber Feet

Mounting with rubber feet results in quieter operation and less workbench vibration. In these set-ups, feet are typically compressed about 25%. Locking hex nuts must be used to prevent the mounting bolts from loosening.

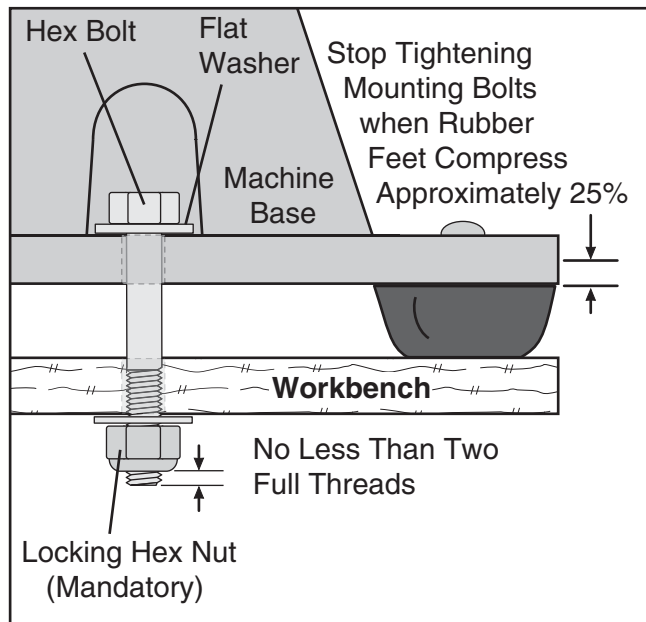

Figure 7. "Through Mount" with rubber feet installed.

Through Mounting

This is a common option for large grinders or high-precision operations when maximum rigidity is required to prevent an out-of-round grinding wheel or workpiece hop.

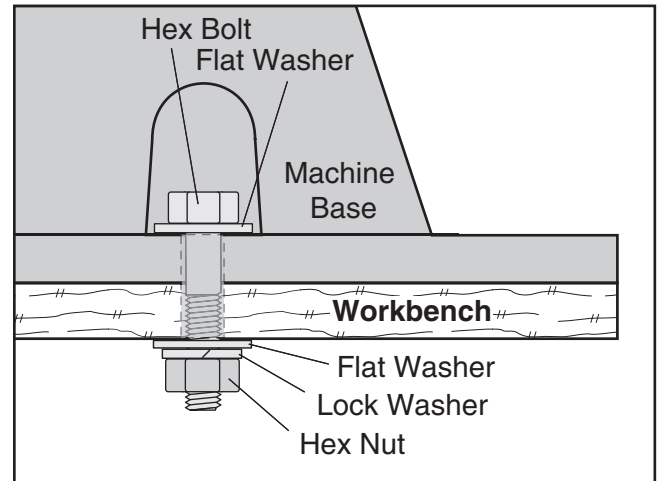

Figure 8. Through mount using nuts and bolts.

Surface Mounting

Popular option for smaller fractional HP grinders. Lag screws are installed into pre-drilled holes in the table top. Sometimes glue is applied to serve as thread lock to prevent fasteners loosening from vibration.

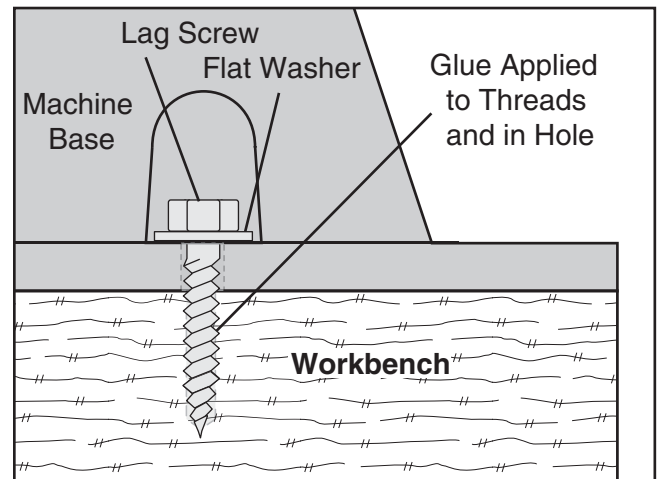

Figure 9. Surface mount using lag screws.



Assembly

Using the hardware from the **Inventory** list on **Page 11**, assemble the tool rest and safety shield as they are shown in **Figure 10**.

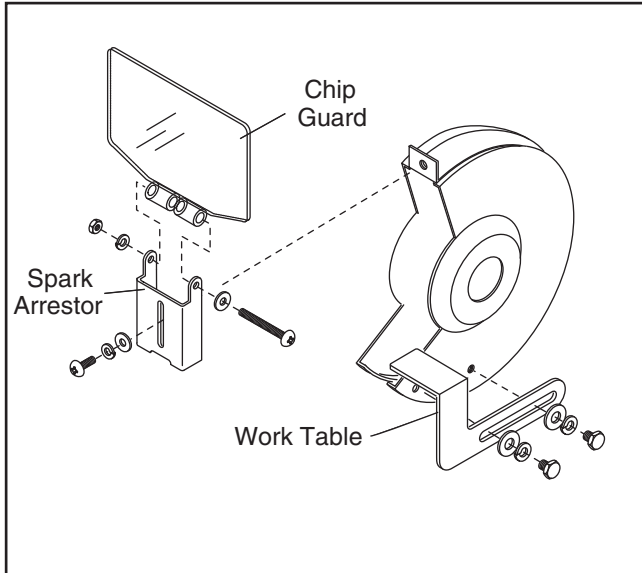

Figure 10. Model T24463 spark deflector, safety shield, and tool rest installation.

Note: The tool rests on Model T24464 attach using (1) M6-1 knob and (1) M6-1 x 14 carriage bolt.

Spark Deflector Adjustment

The spark deflector prevents sparks from showering the top of the workpiece. As the wheel wears, adjust the spark deflector closer to the grinding wheel to maintain a gap of $\frac{1}{8}$ "– $\frac{1}{4}$ " (see **Figure 11**). When the gap reaches $\frac{1}{4}$ " and no additional adjustments can be made, replace the grinding wheel.

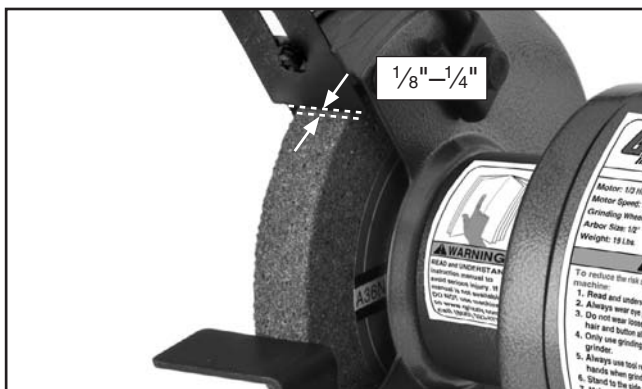

Figure 11. Spark deflector gap.

Tool Rest Adjustment

The tool rest stabilizes the workpiece when grinding. It must always be positioned correctly when using the grinder. As the grinding wheel wears, adjust the tool rest closer to the grinding wheel to maintain a gap of $\frac{1}{16}$ "– $\frac{1}{8}$ " (see **Figure 10**). When the gap reaches $\frac{1}{8}$ " and no additional adjustments can be made, replace the grinding wheel.



Figure 12. Model T24463 tool rest gap.

⚠ CAUTION

NEVER grind without the tool rest in place and properly positioned. "Free hand" grinding or too large of a gap between the wheel and the tool rest increases the risk of kick-back, which may lead to serious injury.

NOTICE

Some grinding wheels must be replaced before the spark deflector or the tool rest reach their final adjustment. As the diameter of a grinding wheel is reduced, so is the available surface speed. Grinding under these conditions can lead to faster abrasive loss and poor grinding results. Always follow the wheel manufacturer's directions.



Power Connection

After you have completed all previous setup instructions and circuit requirements, the machine is ready to be connected to the power supply.

To avoid unexpected startups or cord damage, use the following steps whenever connecting or disconnecting the machine.

Connecting Power

1. Turn the machine power switch **OFF**.
2. Insert the power cord plug into a matching power supply receptacle. The machine is now connected to the power source.

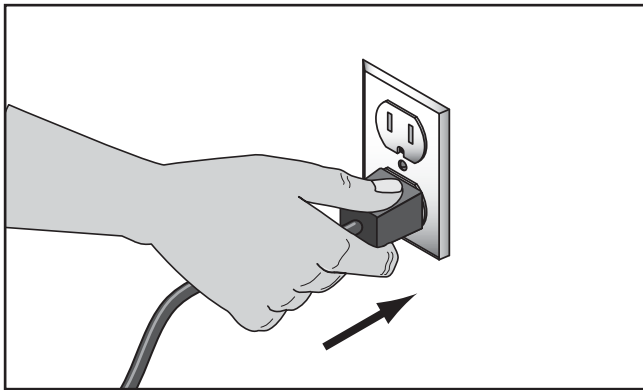

Figure 13. Connecting power.

Disconnecting Power

1. Turn the machine power switch **OFF**.
2. Grasp the molded plug and pull it completely out of the receptacle. Do not pull by the cord as this may damage the wires inside.

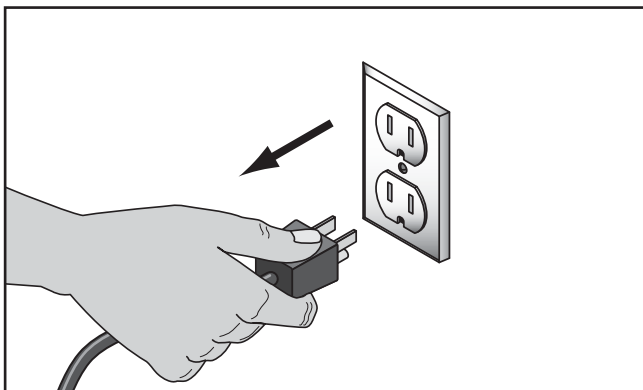

Figure 14. Disconnecting power.

Test Run

Once the assembly is complete, test run your machine to make sure it runs properly and is ready for regular operation.

If, during the test run, you cannot easily locate the source of an unusual noise or vibration, stop using the machine immediately, then review **Troubleshooting on Page 22**.

If you still cannot remedy a problem, contact our Tech Support at (570) 546-9663 for assistance.

To test run the machine:

1. Connect the machine to the power source.
2. Make sure you have read the safety instructions at the beginning of the manual and that the machine is setup properly.
3. Make sure all tools and objects used during setup are cleared away from the machine.
4. Verify that the machine is operating correctly by turning it **ON**.

—When operating correctly, the machine runs smoothly with little or no vibration or rubbing noises.

—Investigate and correct strange or unusual noises or vibrations before operating the machine further. Always disconnect the machine from power when investigating or correcting potential problems.

5. Turn the machine **OFF**.



SECTION 4: OPERATIONS

Operation Overview

The purpose of this overview is to provide the novice machine operator with a basic understanding of how the machine is used during operation, so the machine controls/components discussed later in this manual are easier to understand.

Due to the generic nature of this overview, it is **not** intended to be an instructional guide. To learn more about specific operations, read this entire manual and seek additional training from experienced machine operators, and do additional research outside of this manual by reading "how-to" books, trade magazines, or websites.

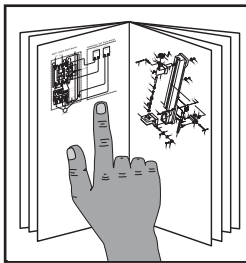

!WARNING
To reduce the risk of serious injury when using this bench grinder, read and understand this entire manual before operating.

!WARNING

Damage to your eyes, lungs, and ears could result from using this machine without proper protective gear. Always wear safety goggles, a face shield, and a respirator when operating this machine.

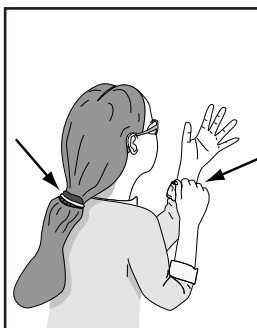
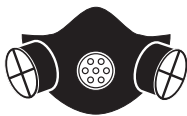
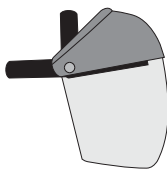

!WARNING
Loose hair and clothing could get caught in machinery and cause serious personal injury. Keep loose clothing and long hair away from moving machinery.

To complete a typical operation, the operator does the following:

1. Examines the workpiece to make sure it is suitable for grinding.
2. Selects the correct grinding wheel for the type of workpiece grinding, inspects the wheel, performs a "ring test", and installs the wheel.
3. Verifies/adjusts the tool rest position so it is perpendicular to the grinding wheel and the gap is $\frac{1}{16}$ " to $\frac{1}{8}$ ".
4. Verifies/adjusts the spark deflector and wheel gap is between $\frac{1}{8}$ " to $\frac{1}{4}$ ".
5. Positions the safety shield for safe grinding.
6. Double checks that no combustibles or flammable materials are near and removes all potential ignition hazards.
7. Ensures that the ON/OFF switch is in the **OFF** position, and connects the grinder to power.
8. Puts on safety goggles, face shield, and respirator.
9. Stands aside, starts the grinder, and allows it to reach full speed.
10. Places the workpiece on the tool rest and positions it for grinding.
11. Using just enough force to allow the wheel to warm up evenly and get the job done, the operator gradually feeds the workpiece into the grinding wheel and moves the workpiece left and right to prevent grooves in the wheel.
12. Quenches the workpiece as required to prevent surface hardening or temper loss.
13. Stops the bench grinder.



WARNING

DO NOT use this grinder with a liquid cooling system required for wet grinding wheel operations. The electrical system is not waterproof. Ignoring this warning can lead to electrocution or machine damage.

Some workpieces are not suitable for grinding on a bench grinder. **Before grinding, inspect all workpieces for the following:**

- **Hard Workpiece:** Workpieces that are made of stone, carbide, stainless steel, ceramics, glass, or have hardened welds will wear out most general grade grinding wheels quickly. If hard materials are to be ground, you must install the correct type of grinding wheel.
- **Soft Workpiece:** Workpieces that are made of aluminum, brass, lead, and other nonferrous metals will load up in the grinding wheel and render the abrasive useless. Grinding wood, plastics, rubber, fiberglass, or other soft materials can also cause the same problem and lead to the wheel overheating and may burst during use if ignored. To restore a loaded grinding wheel surface redress with a dressing tool.
- **Flexible/Unstable Workpiece:** Grinding on the side or the ends of cable, chain, or round workpieces creates the hazard of workpiece twist or grab leading to entanglement with the wheel or shaft. This hazard must be avoided.
- **Loose Parts:** Make sure that the workpiece is free of any parts like springs, pins, balls, or other components that may loosen or dislodge during grinding, and hit the operator.
- **Strength:** Make sure that the workpiece is strong enough to be ground. Should it break, the broken piece may dig into the wheel and cause kickback or severe injury.

Wheel Selection

The Model T24463/T24464 only accepts Type 1 wheels with a 1/2" bore.

Aluminum oxide and silicon carbide wheels are marked in a somewhat uniform manner by all the major manufacturers. Understanding these markings will help you understand the capabilities of various wheels. Always refer to the manufacturer's grinding recommendations when selecting a wheel for your project.

The basic format for wheel numbering is:

Prefix	Abrasive Type	Grit Size	Grade	Bond Type
1	A	60	L	V

The **Prefix** is the manufacturer's designation for a particular wheel type (eg, Type 1 wheels).

The most common **Abrasive Types** used are A for Aluminum Oxide, C for Silicon Carbide, and occasionally SG for Seeded Gel.

The **Grit Size** is a number that refers to the size of the abrasive grain in the wheel. The lower the number, the coarser the wheel. Ten is a very coarse wheel for roughing and 220 is usually the upper range for fine finish work.

Grade is an indication of the hardness of the wheel—"A" being the softest and "Z" being the hardest.

Bond Type refers to the type of bonding material used to hold the abrasive material. Most general purpose wheels will have a "V" indicating Vitrified Clay is used. Vitrified Clay provides high strength and good porosity. The other common bond type is "B" for resin where synthetic resins are used. These are used to grind cemented carbide and ceramic materials.

Note: *There may be other numbers inserted that have meaning for a particular type of wheel. Refer to the manufacturer's technical data for a complete explanation.*



Wheel Inspection

Before mounting a new grinding wheel, it must be inspected. Do not assume that a wheel is in sound condition just because it is new—often damage can occur in shipping, with age, or with exposure to moisture.

First, do a **Visual Inspection**. Look for any cracks, chips, nicks or dents in the surface of the wheel. If you see any of these, **DO NOT** use the wheel.

Second, do a **Ring Test**. This test will give you an indication of any internal damage that may not be obvious during a visual inspection.

To perform a Ring Test:

1. Make sure the wheel that you test is clean and dry; otherwise, you may get false results.
2. If size permits, balance the wheel with your finger in the hole. If this is not possible, hang the wheel in the air with a piece of cord or string looped through the hole in the center.
3. At the spots shown in **Figure 15**, gently tap the wheel with a light non-metallic device such as the handle of a screwdriver or a wooden mallet.

Note: Finding the exact spot to tap will take several attempts.

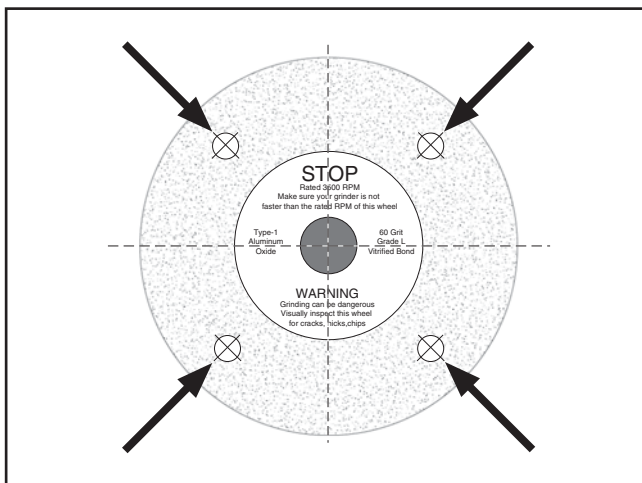

Figure 15. Tapping locations when performing a ring test.

4. An undamaged wheel will emit a clear metallic ring or “ping” sound in each of these spots. A damaged wheel will respond with a dull thud that has no clear tone.
5. If you determine from the ring test that the wheel is damaged, **DO NOT** use it!

Wheel Dressing

Depending on the type of grinding you do, the grinding wheel may require periodic dressing.

There are several different types of wheel dressing devices available on the market (see **Page 20** for one example). Dressing restores the abrasive quality of the wheel surface and brings the wheel edge back to a square form.

For Model T24464:

Refer to the instructions that accompany your dressing accessory for complete details on how to properly dress the wheel.

For Model T24463:

1. Turn the grinder **ON**.
2. Place the wheel dresser on the tool rest with the dressing wheels toward the grinding wheel.
3. Slowly move the dressing wheel toward the grinding wheel and maintain slight pressure until a clear grinding surface appears on the wheel.
4. Turn the grinder **OFF**.
5. Adjust the spark deflector and tool rest per the instructions on **Page 14**.

CAUTION

Always adjust the tool rest and spark deflector after dressing or replacing the grinding wheel. Failure to do so could lead to workpiece kickback and injury.



Wheel Removal & Installation

⚠ CAUTION

ALWAYS visually inspect and perform a “ring test” on a wheel before assembly. **DO NOT** use damaged wheels!

Before installing any wheel, perform a “ring test” to make sure it is free of cracks. Never use a wheel which is suspected of having cracks, is damp, or if there are visual chips, nicks or dents in the wheel surface. Refer to the in-depth safety warnings in the **Safety Section** before installing the wheel.

To remove and install a grinding wheel:

1. DISCONNECT MACHINE FROM POWER!
2. Remove the three Phillips head screws and nuts which go through the outer guard.
3. Remove the outer guard and rim guard (as shown in **Figure 4**).
4. Use a 3/4" or 19mm open end wrench to remove the spindle nut. Hold the wheel from turning with the other hand.

Note: The spindle on the left side of the machine has left hand threads. Turn it clockwise to loosen.

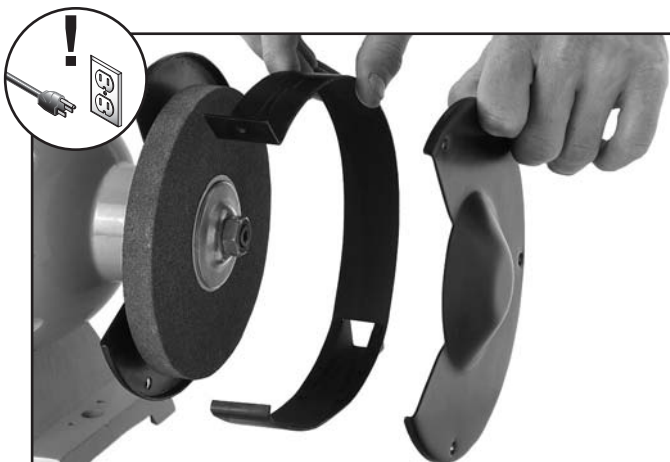

Figure 16. Model T24464 wheel guard components.

5. Remove the outer wheel flange and the paper disc.
6. Remove the wheel from the spindle. Notice the paper or fiber disc between the wheel flanges and the wheel itself. This helps to spread the rotational forces across the inner area of the wheel (see **Figure 17**).

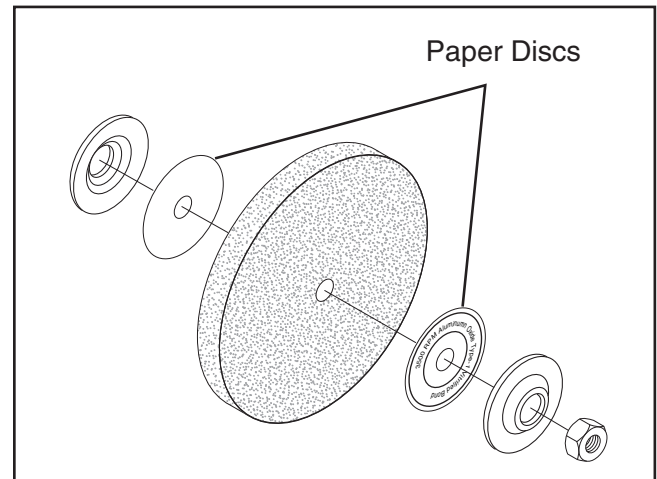

Figure 17. Assembly order for wheel installation.

⚠ CAUTION

NEVER assemble a grinding wheel on the arbor without paper or fiber discs between the wheel and the flange. Not using the discs can put stress on the wheel, causing it to crack and possibly fall apart.

7. Mount the new wheel in the order shown in **Figure 17**. Tighten the nut snugly but do not over tighten. Over tightening can crack the wheel.
8. While standing clear of the line of rotation, turn the machine **ON** and run the new wheel for at least 1-2 minutes.

—If grinder runs smoothly then the wheel may now be used.

—If the wheel appears to wobble, the grinder vibrates excessively, or any other unsafe condition appears with the new wheel, stop the grinder and refer to **Troubleshooting** on **Page 22**.



SECTION 5: ACCESSORIES

Aluminum Oxide Grinding Wheels -Type 1

Model G7408—6" x 3/4" (1/2" Bore) 24 Grit

Model G7409—6" x 3/4" (1/2" Bore) 36 Grit

Model G7410—6" x 3/4" (1/2" Bore) 46 Grit

Model G7411—6" x 3/4" (1/2" Bore) 60 Grit

Silicon Carbide Grinding Wheel

Model G1981—6" x 3/4" (1/2" Bore) 120 Grit

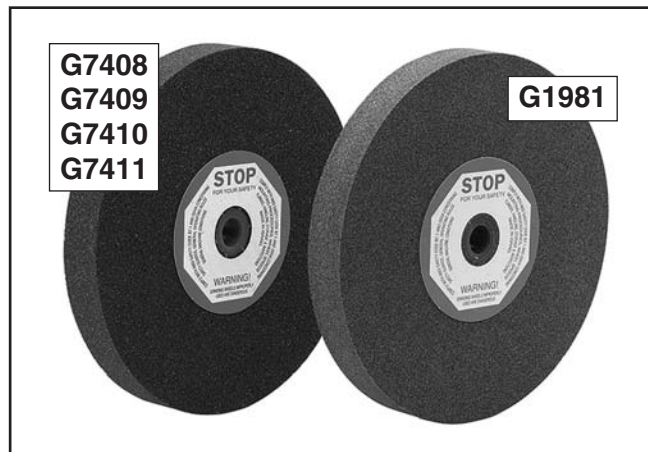

Figure 18. Replacement grinding wheels.

H5891—1/2 Carat Diamond Dresser

H5892—3/4 Carat Diamond Dresser

Industrial diamond for dressing grinding wheels. 8 1/4" long round body with knurled grip for maximum control. Includes protective rubber end cap.

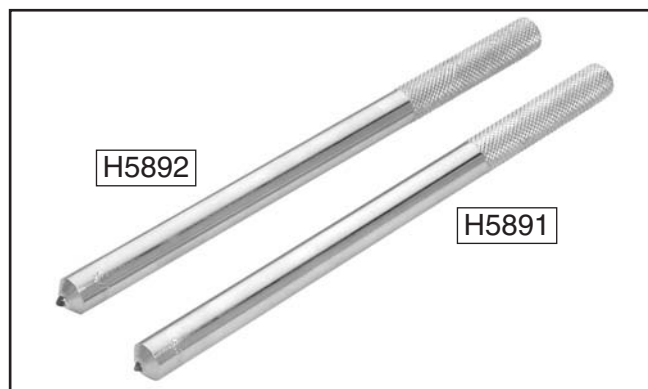

Figure 19. Diamond dressing tools.

Steel Wire Wheels

Model G8765—Knotted Steel Wire Wheel
6" x 1" (1/2" Bore) 0.020" Wire Dia.

Model G8762—Brass Coated Wire Wheel
6" x 1" (1/2" Bore) 0.0125" Wire Dia.

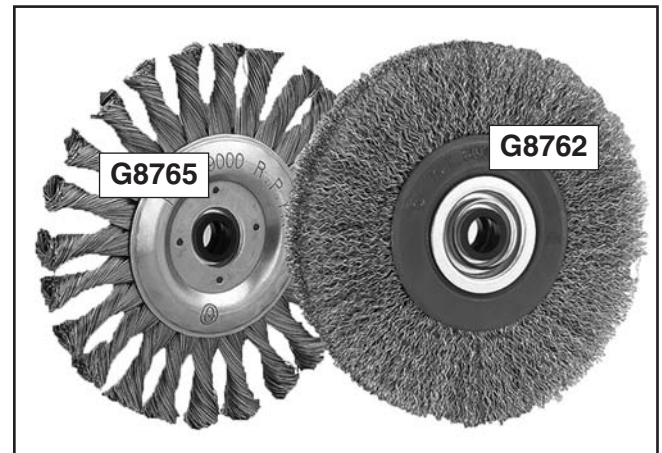

Figure 20. Wire wheels.

Model H5944—#0 Wheel Dresser

Model H5945—#1 Wheel Dresser

Model H5946—#2 Wheel Dresser

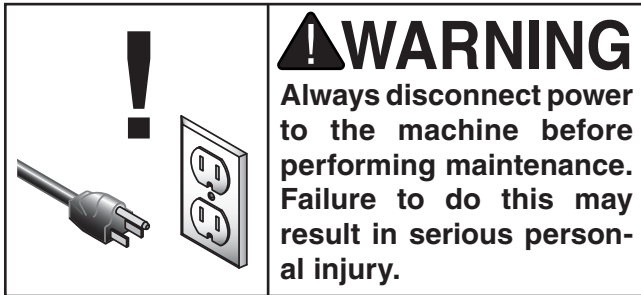

Figure 21. Rotary type dressing tools.

Call 1-800-523-4777 To Order



SECTION 6: MAINTENANCE



Schedule

For optimum performance from your machine, follow this maintenance schedule and refer to any specific instructions given in this section. Routinely check the condition of the following items and repair or replace as necessary:

- Cracked or loose grinding wheel.
- Loose mounting bolts.
- Worn switch.
- Worn or damaged cords and plugs.
- Any other condition that could hamper the safe operation of this machine.

Grinding Wheels

The grinding wheel should be inspected before every use. Use the ring test method noted in **Wheel Inspection** on **Page 18** to verify the structural integrity. Take care in storing grinding wheels to keep them free from potential damage by being dropped or having other items drop on them.

Replace the wheel when the spark deflector or tool rest has no more adjustment and the gap has exceeded the safe limit.

Wheel Dressing

Depending on the type of grinding you do, the grinding wheel may require periodic dressing.

Several different kinds of wheel dressing devices are available. Dressing restores the abrasive quality of the wheel surface and squares up the wheel edge.

For Model T24464, refer to the instructions that accompany your dressing accessory for complete details on how to properly dress a wheel. For Model T24463, refer to **Page 18** for detailed instructions.

Replacing Light Bulb

Replacement BulbPT24463062

To remove the bulb, gently push the bulb down and turn it counter clockwise.

Insert the new bulb by pressing down gently and turning it clockwise until it stops.



SECTION 7: SERVICE

Review the troubleshooting and procedures in this section if a problem develops with your machine. If you need replacement parts or additional help with a procedure, call our Technical Support at (570) 546-9663.

Note: Please gather the serial number and manufacture date of your machine before calling.

Troubleshooting

Symptom	Possible Cause	Possible Solution
Motor will not start.	<ol style="list-style-type: none"> 1. Low voltage. 2. Open circuit in motor or loose connections. 	<ol style="list-style-type: none"> 1. Check power line for proper voltage. 2. Inspect all lead connections on motor for loose or open connections.
Motor will not start; fuses or circuit breakers blow.	<ol style="list-style-type: none"> 1. Short circuit in line cord or plug. 2. Short circuit in motor or loose connections. 3. Incorrect fuses or circuit breakers in power line. 	<ol style="list-style-type: none"> 1. Inspect cord or plug for damaged insulation and shorted wires. 2. Inspect all connections on motor for loose or shorted terminals or worn insulation. 3. Install correct fuses or circuit breakers.
Motor overheats.	<ol style="list-style-type: none"> 1. Motor overloaded. 	<ol style="list-style-type: none"> 1. Reduce load on motor.
Motor stalls (resulting in blown fuses or tripped circuit).	<ol style="list-style-type: none"> 1. Short circuit in motor or loose connections. 2. Low voltage. 3. Incorrect fuses or circuit breakers in power line. 4. Motor overloaded. 	<ol style="list-style-type: none"> 1. Inspect connections on motor for loose or shorted terminals or worn insulation. 2. Correct the low voltage conditions. 3. Install correct fuses or circuit breakers. 4. Reduce load on motor.
Machine slows when operating.	<ol style="list-style-type: none"> 1. Operator is using too much pressure. 	<ol style="list-style-type: none"> 1. Use less pressure when grinding.
Wavy condition on surface of workpiece.	<ol style="list-style-type: none"> 1. Machine vibrating. 2. Workpiece not being held firmly. 3. Wheel face uneven. 4. Wheel is too hard. 	<ol style="list-style-type: none"> 1. Make sure machine is securely mounted on a solid surface. 2. Use a holding device to firmly retain the workpiece. 3. Dress the grinding wheel. 4. Use softer wheel, or reduce the feed rate.
Lines on surface of workpiece.	<ol style="list-style-type: none"> 1. Impurity on wheel surface. 	<ol style="list-style-type: none"> 1. Dress the grinding wheel.
Burning spots or cracks in the workpiece.	<ol style="list-style-type: none"> 1. Improper type of grinding wheel. 2. Improper feed rate. 3. Coolant required. 	<ol style="list-style-type: none"> 1. Try a wheel which is softer style or a coarser grit. 2. Slow down the rate of movement of the workpiece into wheel. 3. Introduce coolant by hand.
Wheel dulls quickly, grit falls off.	<ol style="list-style-type: none"> 1. Depth of cut too great. 2. Wheel is too soft. 3. Wheel diameter too small. 4. Bad wheel dress. 5. Defective wheel bonding. 	<ol style="list-style-type: none"> 1. Slow down the rate of movement of the workpiece into wheel. 2. Wheel too soft for the material being ground, select harder bond. 3. Replace the wheel. 4. Dress the wheel. 5. Consult manufacturer of grinding wheel.



SECTION 8: WIRING

These pages are current at the time of printing. However, in the spirit of improvement, we may make changes to the electrical systems of future machines. Compare the manufacture date of your machine to the one stated in this manual, and study this section carefully.

If there are differences between your machine and what is shown in this section, call Technical Support at (570) 546-9663 for assistance BEFORE making any changes to the wiring on your machine. An updated wiring diagram may be available. **Note:** *Please gather the serial number and manufacture date of your machine before calling. This information can be found on the main machine label.*

WARNING

Wiring Safety Instructions

SHOCK HAZARD. Working on wiring that is connected to a power source is extremely dangerous. Touching electrified parts will result in personal injury including but not limited to severe burns, electrocution, or death. Disconnect the power from the machine before servicing electrical components!

MODIFICATIONS. Modifying the wiring beyond what is shown in the diagram may lead to unpredictable results, including serious injury or fire. This includes the installation of unapproved after-market parts.

WIRE CONNECTIONS. All connections must be tight to prevent wires from loosening during machine operation. Double-check all wires disconnected or connected during any wiring task to ensure tight connections.

CIRCUIT REQUIREMENTS. You MUST follow the requirements at the beginning of this manual when connecting your machine to a power source.

WIRE/COMPONENT DAMAGE. Damaged wires or components increase the risk of serious personal injury, fire, or machine damage. If you notice that any wires or components are damaged while performing a wiring task, replace those wires or components.

MOTOR WIRING. The motor wiring shown in these diagrams is current at the time of printing but may not match your machine. If you find this to be the case, use the wiring diagram inside the motor junction box.







CAPACITORS/INVERTERS. Some capacitors and power inverters store an electrical charge for up to 10 minutes after being disconnected from the power source. To reduce the risk of being shocked, wait at least this long before working on capacitors.

EXPERIENCING DIFFICULTIES. If you are experiencing difficulties understanding the information included in this section, contact our Technical Support at (570) 546-9663.

NOTICE

The photos and diagrams included in this section are best viewed in color. You can view these pages in color at www.grizzly.com.

COLOR KEY

BLACK 	BLUE 	YELLOW 	LIGHT BLUE 
WHITE 	BROWN 	YELLOW GREEN 	BLUE WHITE 
GREEN 	GRAY 	PURPLE 	TURQUOISE 
RED 	ORANGE 	PINK 	



T24464 Wiring

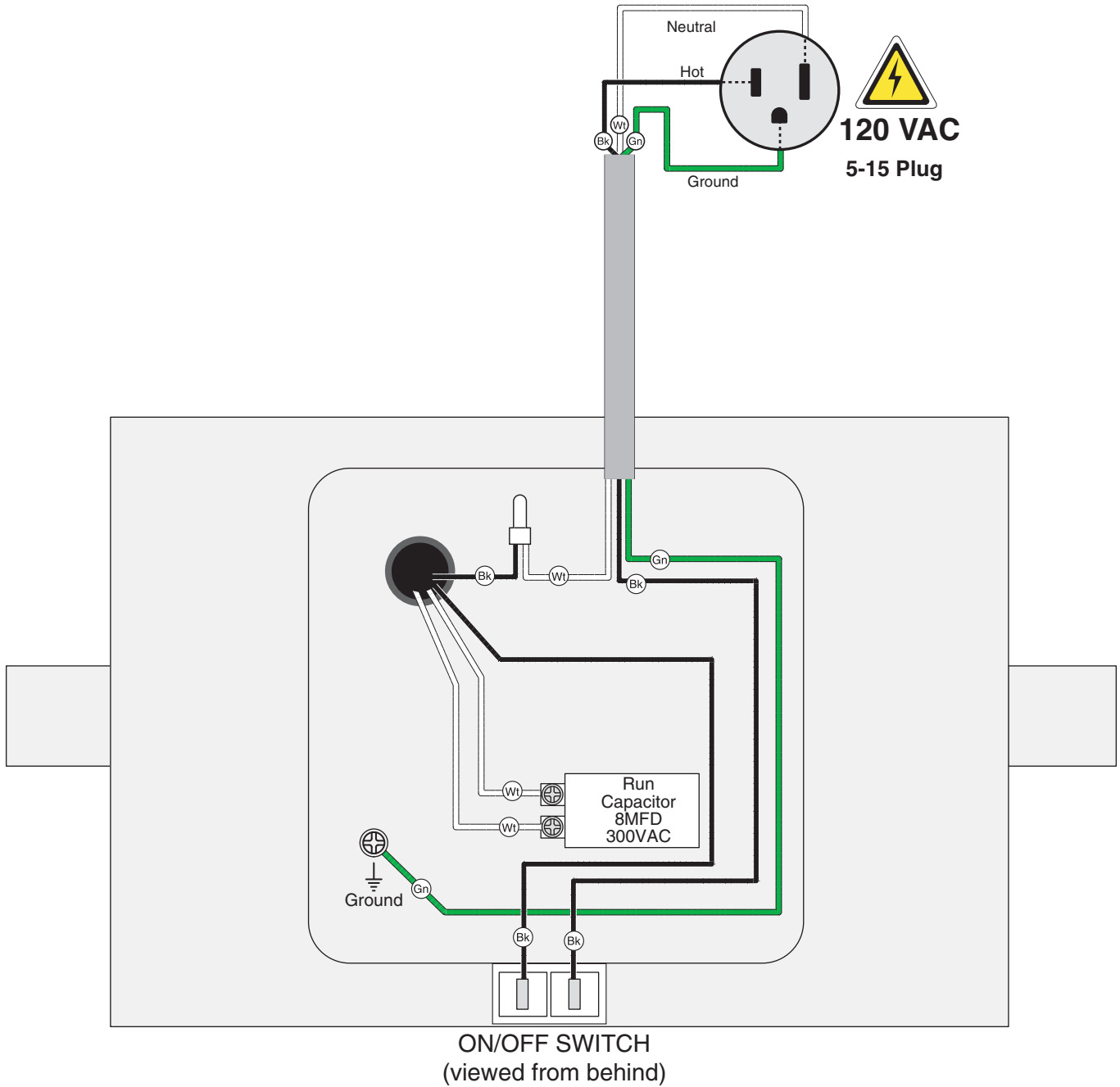

SECTION 9: PARTS

T24463 Breakdown

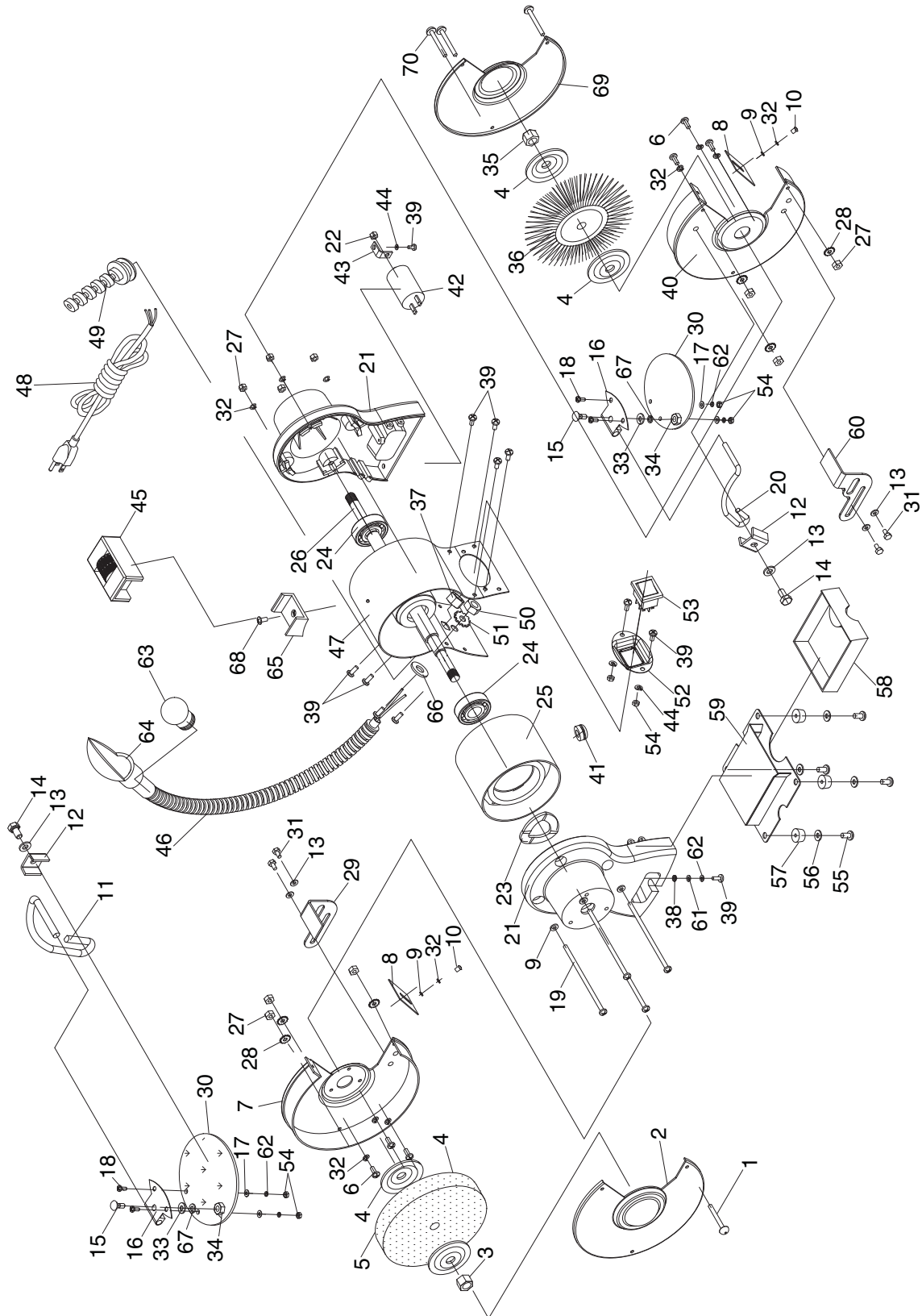

T24463 Parts List

REF	PART #	DESCRIPTION
1	PS54M	PHLP HD SCR M5-.8 X 45
2	PT24463002	LEFT WHEEL COVER
3	PN09M	HEX NUT M12-1.75
4	PT24463004	WHEEL FLANGE
5	PT24463005	WHEEL 6 X 3/4 X 1/2 36-GRIT
6	PS09M	PHLP HD SCR M5-.8 X 10
7	PT24463007	LEFT GUARD
8	PT24463008	SPARK DEFLECTOR
9	PW02M	FLAT WASHER 5MM
10	PS05M	PHLP HD SCR M5-.8 X 8
11	PT24463011	LEFT SAFETY SHIELD ARM
12	PT24463012	ARM BRACKET
13	PW01M	FLAT WASHER 8MM
14	PB84M	HEX BOLT M8-1.25 X 14
15	PCB22M	CARRIAGE BOLT M6-1 X 16
16	PT24463016	SAFETY SHIELD BRACKET
17	PW05M	FLAT WASHER 4MM
18	PS38M	PHLP HD SCR M4-.7 X 10
19	PS120M	PHLP HD SCR M5-.8 X 124
20	PT24463020	RIGHT SAFETY SHIELD ARM
21	PT24463021	END BELL
22	PN03M	HEX NUT M8-1.25
23	PT24463023	DISC SPRING
24	P6202ZZ	BALL BEARING 6202ZZ
25	PT24463025	STATOR
26	PT24463026	ROTOR
27	PN06M	HEX NUT M5-.8
28	PLW01M	LOCK WASHER 5MM
29	PT24463029	LEFT TOOL REST
30	PT24463030	SAFETY SHIELD
31	PB192M	HEX BOLT M8-1.25 X 8
32	PLW01M	LOCK WASHER 5MM
33	PW03M	FLAT WASHER 6MM
34	PN01M	HEX NUT M6-1
35	PT24463035	NUT M12-1.75

REF	PART #	DESCRIPTION
36	PT24463036	WIRE WHEEL 6 X 3/4 X 1/2
37	PT24463037	LOCK NUT 16MM
38	PTLW01M	EXT TOOTH WASHER 4MM
39	PS07M	PHLP HD SCR M4-.7 X 8
40	PT24463040	RIGHT GUARD
41	PT24463041	CORD GROMMET
42	PT24463042	CAPACITOR 8M 300V
43	PT24463043	CAPACITOR SUPPORT
44	PLW02M	LOCK WASHER 4MM
45	PT24463045	WHEEL DRESSING TOOL
46	PT24463046	LAMP NECK
47	PT24463047	MAIN HOUSING
48	PT24463048	POWER CORD 16AWG 3W 5-15 78"
49	PT24463049	CORD GRIP
50	PN02M	HEX NUT M10-1.5
51	PTLW08M	EXT TOOTH WASHER 10MM
52	PT24463052	SWITCH PLATE
53	PT24463053	SWITCH KTL T85 120V
54	PN04M	HEX NUT M4-.7
55	PS56M	PHLP HD SCR M4-.7 X 16
56	PW05M	FLAT WASHER 4MM
57	PT24463057	RUBBER FOOT
58	PT24463058	COOLANT TRAY
59	PT24463059	BOTTOM PLATE
60	PT24463060	RIGHT TOOL REST
61	PW05M	FLAT WASHER 4MM
62	PLW02M	LOCK WASHER 4MM
63	PT24463063	LIGHT BULB 120V 10W BAS25 INC
64	PT24463064	LAMP ASSEMBLY
65	PT24463065	WHEEL DRESSING TOOL BASE
66	PW04M	FLAT WASHER 10MM
67	PLW03M	LOCK WASHER 6MM
68	PS05M	PHLP HD SCR M5-.8 X 8
69	PT24463069	RIGHT WHEEL COVER
70	PS102M	PHLP HD SCR M5-.8 X 50



T24464 Breakdown

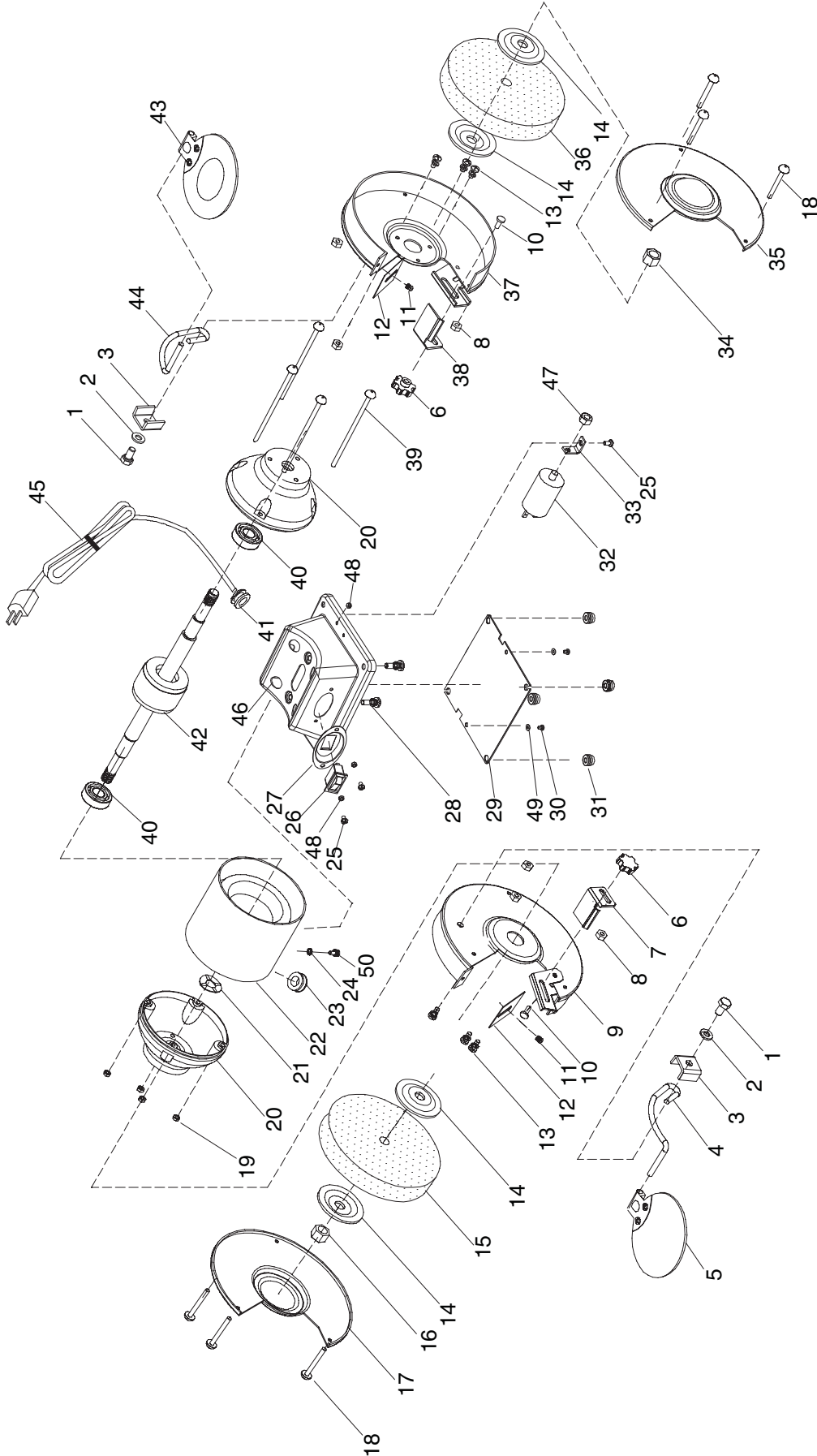

T24464 Parts List

REF	PART #	DESCRIPTION
1	PB84M	HEX BOLT M8-1.25 X 14
2	PW01M	FLAT WASHER 8MM
3	PT24464003	BRACKET
4	PT24464004	LEFT SAFETY SHIELD SUPPORT
5	PT24464005	PLATE SAFETY SHIELD ASSY
6	PT24464006	STAR KNOB M6-1 6PT
7	PT24464007	LEFT TOOL REST
8	PN06M	HEX NUT M5-.8
9	PT24464009	LEFT WHEEL GUARD
10	PT24464010	CARRIAGE BOLT M6-1 X 14
11	PS09M	PHLP HD SCR M5-.8 X 10
12	PT24464012	SPARK DEFLECTOR
13	PS09M	PHLP HD SCR M5-.8 X 10
14	PT24464014	WHEEL FLANGE
15	PT24464015	WHEEL 6 X 3/4 X 1/2 36-GRIT
16	PN09M	HEX NUT M12-1.75
17	PT24464017	LEFT WHEEL COVER
18	PT24464018	PHLP HD SCR M5-.8 X 40
19	PT24464019	FLANGE HEX NUT M4-.7
20	PT24464020	END BELL
21	PT24464021	DISC SPRING 1/2
22	PT24464022	STATOR
23	PT24464023	CORD GROMMET
24	PLW02M	LOCK WASHER 4MM
25	PS07M	PHLP HD SCR M4-.7 X 8

REF	PART #	DESCRIPTION
26	PT24464026	SWITCH KTL T85 120V
27	PT24464027	SWITCH PLATE
28	PS07M	PHLP HD SCR M4-.7 X 8
29	PT24464029	BOTTOM PLATE
30	PS05M	PHLP HD SCR M5-.8 X 8
31	PT24464031	RUBBER FOOT
32	PT24464032	R CAPACITOR 8M 300V
33	PT24464033	CAPACITOR SUPPORT
34	PN09M	HEX NUT M12-1.75
35	PT24464035	RIGHT WHEEL COVER
36	PT24464036	WHEEL 6 X 3/4 X 1/2 60-GRIT
37	PT24464037	RIGHT WHEEL GUARD
38	PT24464038	RIGHT TOOL REST
39	PS119M	PHLP HD SCR M4-.7 X 118
40	P6002ZZ	BALL BEARING 6002ZZ
41	PT24464041	CORD CLIP
42	PT24464042	ROTOR
43	PT24464043	MAGNIFIED SAFETY SHIELD ASSY
44	PT24464044	RIGHT SAFETY SHIELD SUPPORT
45	PT24464045	POWER CORD 16AWG 3W 5-15 78"
46	PT24464046	BASE
47	PN03M	HEX NUT M8-1.25
48	PT24464048	FLANGE HEX NUT M4-.7
49	PW02M	FLAT WASHER 5MM
50	PS07M	PHLP HD SCR M4-.7 X 8



T24463/T24464 Labels



REF	PART #	DESCRIPTION
101	PLABEL-14A	ELECTRICITY LABEL 0.7W X 0.6H
102	PPAINT-1	GRIZZLY GREEN TOUCH-UP PAINT
103	PLABEL-56A	FACE SHIELD/RESPIRATOR LABEL

REF	PART #	DESCRIPTION
104	PT24463104	MACHINE ID LABEL (T24463)
104	PT24464104	MACHINE ID LABEL (T24464)
105	PLABEL-12C	READ MANUAL LABEL

⚠️ WARNING

Safety labels help reduce the risk of serious injury caused by machine hazards. If any label comes off or becomes unreadable, the owner of this machine **MUST** replace it in the original location before resuming operations. For replacements, contact (800) 523-4777 or www.grizzly.com.





WARRANTY CARD

Name _____
 Street _____
 City _____ State _____ Zip _____
 Phone # _____ Email _____ Invoice # _____
 Model # _____ Order # _____ Serial # _____

The following information is given on a voluntary basis. It will be used for marketing purposes to help us develop better products and services. **Of course, all information is strictly confidential.**

1. How did you learn about us?

<input type="checkbox"/> Advertisement	<input type="checkbox"/> Friend	<input type="checkbox"/> Catalog
<input type="checkbox"/> Card Deck	<input type="checkbox"/> Website	<input type="checkbox"/> Other: _____

2. Which of the following magazines do you subscribe to?

<input type="checkbox"/> Cabinetmaker & FDM	<input type="checkbox"/> Popular Science	<input type="checkbox"/> Wooden Boat
<input type="checkbox"/> Family Handyman	<input type="checkbox"/> Popular Woodworking	<input type="checkbox"/> Woodshop News
<input type="checkbox"/> Hand Loader	<input type="checkbox"/> Precision Shooter	<input type="checkbox"/> Woodsmith
<input type="checkbox"/> Handy	<input type="checkbox"/> Projects in Metal	<input type="checkbox"/> Woodwork
<input type="checkbox"/> Home Shop Machinist	<input type="checkbox"/> RC Modeler	<input type="checkbox"/> Woodworker West
<input type="checkbox"/> Journal of Light Cont.	<input type="checkbox"/> Rifle	<input type="checkbox"/> Woodworker's Journal
<input type="checkbox"/> Live Steam	<input type="checkbox"/> Shop Notes	<input type="checkbox"/> Other: _____
<input type="checkbox"/> Model Airplane News	<input type="checkbox"/> Shotgun News	
<input type="checkbox"/> Old House Journal	<input type="checkbox"/> Today's Homeowner	
<input type="checkbox"/> Popular Mechanics	<input type="checkbox"/> Wood	

3. What is your annual household income?

<input type="checkbox"/> \$20,000-\$29,000	<input type="checkbox"/> \$30,000-\$39,000	<input type="checkbox"/> \$40,000-\$49,000
<input type="checkbox"/> \$50,000-\$59,000	<input type="checkbox"/> \$60,000-\$69,000	<input type="checkbox"/> \$70,000+

4. What is your age group?

<input type="checkbox"/> 20-29	<input type="checkbox"/> 30-39	<input type="checkbox"/> 40-49
<input type="checkbox"/> 50-59	<input type="checkbox"/> 60-69	<input type="checkbox"/> 70+

5. How long have you been a woodworker/metalworker?

<input type="checkbox"/> 0-2 Years	<input type="checkbox"/> 2-8 Years	<input type="checkbox"/> 8-20 Years	<input type="checkbox"/> 20+ Years
------------------------------------	------------------------------------	-------------------------------------	------------------------------------

6. How many of your machines or tools are Grizzly?

<input type="checkbox"/> 0-2	<input type="checkbox"/> 3-5	<input type="checkbox"/> 6-9	<input type="checkbox"/> 10+
------------------------------	------------------------------	------------------------------	------------------------------

7. Do you think your machine represents a good value? Yes No
8. Would you recommend Grizzly Industrial to a friend? Yes No
9. Would you allow us to use your name as a reference for Grizzly customers in your area?
Note: We never use names more than 3 times. Yes No

10. Comments: _____

CUT ALONG DOTTED LINE

FOLD ALONG DOTTED LINE



Place Stamp Here



GRIZZLY INDUSTRIAL, INC.
P.O. BOX 2069
BELLINGHAM, WA 98227-2069



FOLD ALONG DOTTED LINE

Send a Grizzly Catalog to a friend:

Name _____
Street _____
City _____ State _____ Zip _____

TAPE ALONG EDGES--PLEASE DO NOT STAPLE

WARRANTY & RETURNS

Grizzly Industrial, Inc. warrants every product it sells for a period of **1 year** to the original purchaser from the date of purchase. This warranty does not apply to defects due directly or indirectly to misuse, abuse, negligence, accidents, repairs or alterations or lack of maintenance. This is Grizzly's sole written warranty and any and all warranties that may be implied by law, including any merchantability or fitness, for any particular purpose, are hereby limited to the duration of this written warranty. We do not warrant or represent that the merchandise complies with the provisions of any law or acts unless the manufacturer so warrants. In no event shall Grizzly's liability under this warranty exceed the purchase price paid for the product and any legal actions brought against Grizzly shall be tried in the State of Washington, County of Whatcom.

We shall in no event be liable for death, injuries to persons or property or for incidental, contingent, special, or consequential damages arising from the use of our products.

To take advantage of this warranty, contact us by mail or phone and give us all the details. We will then issue you a "Return Number," which must be clearly posted on the outside as well as the inside of the carton. We will not accept any item back without this number. Proof of purchase must accompany the merchandise.

The manufacturers reserve the right to change specifications at any time because they constantly strive to achieve better quality equipment. We make every effort to ensure that our products meet high quality and durability standards and we hope you never need to use this warranty.

Please feel free to write or call us if you have any questions about the machine or the manual.

Thank you again for your business and continued support. We hope to serve you again soon.

grizzly.com[®]

TOOL WEBSITE

Buy Direct and Save with Grizzly[®] – Trusted, Proven and a Great Value!
~Since 1983~

*Visit Our Website Today For
Current Specials!*

**ORDER
24 HOURS A DAY!
1-800-523-4777**



Free Manuals Download Website

<http://myh66.com>

<http://usermanuals.us>

<http://www.somanuals.com>

<http://www.4manuals.cc>

<http://www.manual-lib.com>

<http://www.404manual.com>

<http://www.luxmanual.com>

<http://aubethermostatmanual.com>

Golf course search by state

<http://golfingnear.com>

Email search by domain

<http://emailbydomain.com>

Auto manuals search

<http://auto.somanuals.com>

TV manuals search

<http://tv.somanuals.com>