

Grizzly *Industrial, Inc.*®

MODEL T23096 INDUSTRIAL 1/4" DIE GRINDER OWNER'S MANUAL



COPYRIGHT © APRIL, 2011 BY GRIZZLY INDUSTRIAL, INC.
**WARNING: NO PORTION OF THIS MANUAL MAY BE REPRODUCED IN ANY SHAPE
OR FORM WITHOUT THE WRITTEN APPROVAL OF GRIZZLY INDUSTRIAL, INC.**
#CR14037 PRINTED IN CHINA



WARNING!

This manual provides critical safety instructions on the proper setup, operation, maintenance, and service of this machine/tool. Save this document, refer to it often, and use it to instruct other operators.

Failure to read, understand and follow the instructions in this manual may result in fire or serious personal injury—including amputation, electrocution, or death.

The owner of this machine/tool is solely responsible for its safe use. This responsibility includes but is not limited to proper installation in a safe environment, personnel training and usage authorization, proper inspection and maintenance, manual availability and comprehension, application of safety devices, cutting/sanding/grinding tool integrity, and the usage of personal protective equipment.

The manufacturer will not be held liable for injury or property damage from negligence, improper training, machine modifications or misuse.



WARNING!

Some dust created by power sanding, sawing, grinding, drilling, and other construction activities contains chemicals known to the State of California to cause cancer, birth defects or other reproductive harm. Some examples of these chemicals are:

- **Lead from lead-based paints.**
- **Crystalline silica from bricks, cement and other masonry products.**
- **Arsenic and chromium from chemically-treated lumber.**

Your risk from these exposures varies, depending on how often you do this type of work. To reduce your exposure to these chemicals: Work in a well ventilated area, and work with approved safety equipment, such as those dust masks that are specially designed to filter out microscopic particles.

Table of Contents

SAFETY	2
Safety Instructions for Pneumatic Tools	2
Additional Safety Instructions for Pneumatic Die Grinders	3
SECTION 1: INTRODUCTION	4
Foreword	4
Specifications	4
Contact Info	4
Identification	5
SECTION 2: SETUP	6
Unpacking	6
Inventory	6
Assembly	6
SECTION 3: OPERATIONS	7
Operation Overview	7
SECTION 4: ACCESSORIES	8
SECTION 5: MAINTENANCE	10
SECTION 6: SERVICE	11
Troubleshooting	11
SECTION 7: PARTS	13
Main Parts Diagram	13
Main Parts List	13
WARRANTY	14

SAFETY

WARNING

For Your Own Safety Read Instruction Manual Before Operating This Equipment

The purpose of safety symbols is to attract your attention to possible hazardous conditions. This manual uses a series of symbols and signal words which are intended to convey the level of importance of the safety messages. The progression of symbols is described below. Remember that safety messages by themselves do not eliminate danger and are not a substitute for proper accident prevention measures.

DANGER

Indicates an imminent hazardous situation which, if not avoided, **WILL** result in death or serious injury.

WARNING

Indicates a potentially hazardous situation which, if not avoided, **COULD** result in death or serious injury.

CAUTION

Indicates a potentially hazardous situation which, if not avoided, **MAY** result in minor or moderate injury. It may also be used to alert against unsafe practices.

NOTICE

This symbol is used to alert the user to useful information about proper operation of the equipment.

WARNING

Safety Instructions for Pneumatic Tools

KEEP ALL SAFETY DEVICES IN PLACE and in working order.

DO NOT FORCE TOOL. It will do the job better and safer at the rate for which it was designed.

REMOVE ADJUSTING KEYS AND WRENCHES. Form habit of checking to see that keys and adjusting wrenches are removed from tool before operation.

USE THE RIGHT TOOL. Do not force tool or attachment to do a job for which it was not designed.

KEEP WORK AREA CLEAN. Cluttered areas and benches invite accidents.

DO NOT USE UNDER THE INFLUENCE OF DRUGS OR ALCOHOL, OR WHEN TIRED.

KEEP CHILDREN AND VISITORS AWAY. All children and visitors should be kept at a safe distance from work area.

USE CORRECT AIR PRESSURE.

Exceeding the maximum PSI rating of this tool may cause seal damage, unpredictable operation, or line burst.

MAKE WORKSHOP CHILD PROOF. Make sure to lock your shop and shut-**OFF** the power and air supply.

WARNING

USE PROPER AIR HOSE for the tool. Make sure your air hose is in good condition and is long enough to reach your work without stretching.

SECURE WORK. Use clamps or a vise to hold work when practical. It is safer than using your hand and frees both hands to operate tool.

MAINTAIN TOOLS WITH CARE. Cracked grinding stones may break and fly apart during operation. Inspect grinding bits for cracks before each use and replace cracked wheels immediately!

PREVENT ACCIDENTAL OPERATION. Do not carry tool with hand on trigger and always disconnect from air when not in use.

ELECTRICAL SHOCK HAZARD. Cutting into workpieces with hidden wiring can result in shock or electrocution. Check for hidden wiring before making any cuts.

BE AWARE OF HOSE LOCATION. Hoses can easily become a tripping hazard when laid across the floor in a disorganized fashion.

SPEED RATING. Grinding bits and cut-off wheels operated at a faster speed than rated, may break or fly apart. Before installing, make sure the maximum allowable speed for the grinding stone or cut-off wheel is equal or higher than the speed of the tool.

AIR LINE CONNECTION INSPECTION. An air line that becomes disconnected from a tool can whip violently, causing severe injury. Verify that air line is properly connected and the fittings are tight and leak free. Leaking fittings can indicate the fitting is cracked and is about to fail.

WEAR PROPER APPAREL. Do not wear loose clothing, gloves, neckties, rings, bracelets, or other jewelry that may get caught in moving parts. Non-slip footwear is recommended. Wear a protective hair covering to contain long hair.

USE SAFETY GOGGLES. Also use a face or dust mask if cutting operation is dusty. Everyday eyeglasses only have impact resistant lenses, they are NOT safety glasses.

WARNING

Additional Safety Instructions for Pneumatic Die Grinders

CHANGING BITS. When swapping grinding bits, disconnect the grinder from air to prevent an accidental start-up injury.

TOOL STABILITY. To establish the best control possible when grinding, hold the grinder with two hands, and stabilize your hands and body against a fixed object. Free-grinding (using one hand and no support) can allow the tooling to grab the workpiece and cause you to lose your grip on the grinder, leading to severe injury.

CAUTION

No list of safety guidelines can be complete. Every shop environment is different. Always consider safety first, as it applies to your individual working conditions. Use this and other tools with caution and respect. Failure to do so could result in serious personal injury, damage to equipment or poor work results.

SECTION 1: INTRODUCTION

Foreword

We are proud to offer this manual with your new T23096! We've made every effort to be exact with the instructions, specifications, drawings, and photographs of the T23096 we used when writing this manual. However, sometimes we still make an occasional mistake.

Also, owing to our policy of continuous improvement, your T23096 may not exactly match the manual. If you find this to be the case, and the difference between the manual and T23096 leaves you in doubt, check our website for the latest manual update or call technical support for help.

For your convenience, we post all available manuals and manual updates for free on our website at www.grizzly.com. Any updates to your model of tool will be reflected in these documents as soon as they are complete.

Contact Info

We stand behind our products. If you have any service questions, parts requests or general questions about the product, please call or write us at the location listed below.

Grizzly Industrial, Inc.
1203 Lycoming Mall Circle
Muncy, PA 17756
Phone: (570) 546-9663
E-Mail: techsupport@grizzly.com

We want your feedback on this manual. If you can take the time, please email or write to us at the address below and tell us how we did:

Grizzly Industrial, Inc.
C/O Technical Documentation Manager
P.O. Box 2069
Bellingham, WA 98227-2069
Email: manuals@grizzly.com

Specifications

Tool Bit Shank Size.....	1/4"
Free Speed.....	25,000 RPM
Average Air Consumption	3 CFM
Operating Air Pressure.....	90 PSI
Maximum Air Pressure.....	100 PSI
Air Inlet Size	1/4" NPT
Minimum Air Hose Inside Diameter.....	3/8"
Weighted Sound Pressure Level.....	84.1 dB(A)
Sound Power Level	95.1 dB(A)
Handle Vibration Rating	0.8 m/s ²
Net Weight.....	0.88 lbs
Shipping Weight	1.10 lbs

Identification

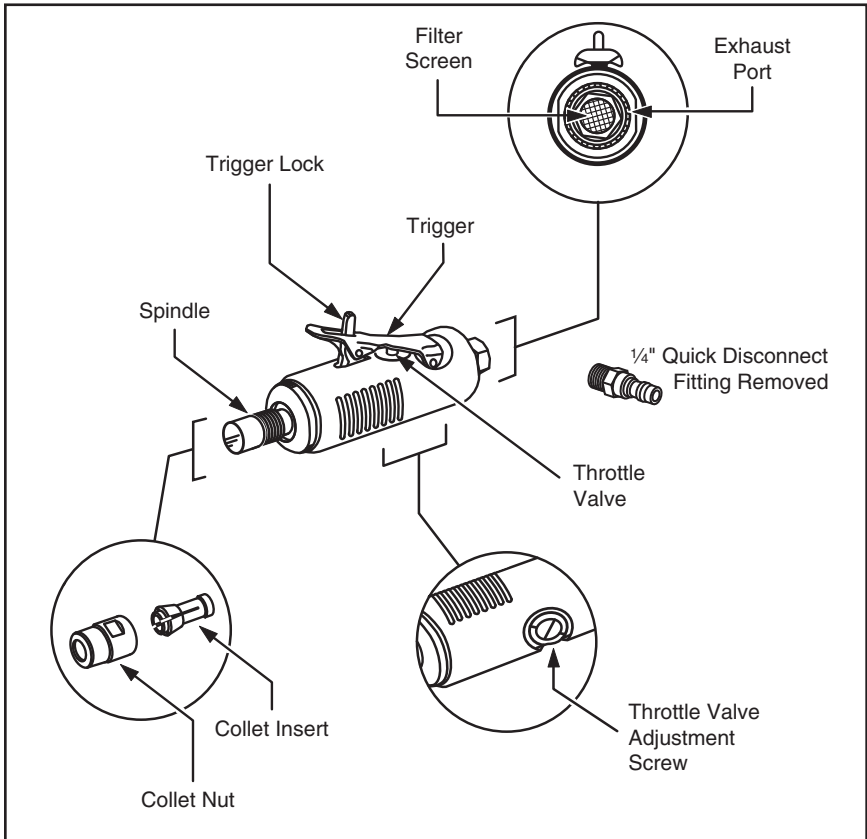

Figure 1. Components and controls.

⚠ WARNING

This tool presents serious injury hazards to untrained users. Read through this entire manual to become familiar with the controls and operations before using the tool!

SECTION 2: SETUP

Unpacking

Your tool was carefully packaged for safe transportation. Remove the packaging materials from around your tool and inspect it. If you discover the tool is damaged, please immediately call Customer Service at (570) 546-9663 for advice.

Save the containers and all packing materials for possible inspection by the carrier or its agent. Otherwise, filing a freight claim can be difficult. When you are completely satisfied with the condition of your shipment, inventory the contents.

If any non-proprietary parts are missing (e.g., a nut or a washer), we will gladly replace them; or for the sake of expediency, replacements can be obtained at your local hardware store.

Inventory

Model T23096 Inventory (Figure 2)

- A. Die Grinder..... 1
- B. Quick Disconnect Air Fitting..... 1
- C. Bottle for Oil..... 1
- D. Spindle Wrench 1/2"..... 1
- E. Collet Nut Wrench 1 1/16"..... 1

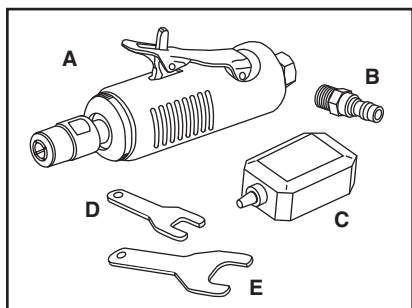

Figure 2. Inventory.

Assembly

To assemble the grinder:

1. Remove the plastic plug from the grinder air inlet.
2. Apply pipe sealant on the quick disconnect fitting threads, and install the fitting into the grinder air inlet.
3. Insert the shank of the desired grinding bit into the collet until it bottoms, and tighten the collet nut (see **Figure 1**) using the spindle and collet wrenches.
4. Release the trigger lock, depress the trigger, place a few drops of air tool oil into the air inlet, and release the trigger. The grinder is ready for use.

Air supply setup tips:

- If the air hose is longer than 25-feet, increase the air pressure to 100 PSI to compensate for air flow restriction.
- For consistent air flow, use air hoses with an inside diameter of 3/8" or larger.
- To eliminate air system moisture and maintain automatic lubrication, install a main or in-line filter water separator as far as possible from the air compressor, but before any automatic in-line oiler. See examples in **Figure 3**.

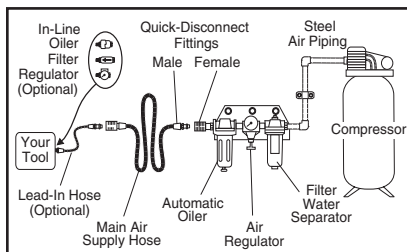
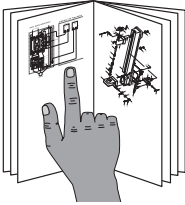

Figure 3. Typical air supply system.

SECTION 3: OPERATIONS

⚠ WARNING



This tool presents serious injury hazards to untrained users. Read through this entire manual to become familiar with the controls and operations before using the tool!

⚠ WARNING



EYE INJURY HAZARD!
Wear safety goggles with full eye protection from all sides when using this grinder.

⚠ WARNING



LUNG/EAR INJURY HAZARD!
Wear protective equipment when using this tool.

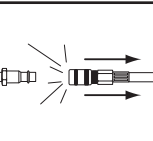

ACCIDENTAL START HAZARD!
Disconnect before service or tool changes.



AIR PRESSURE HAZARD!
Never exceed max PSI rating for tool.

Operation Overview

To complete a typical cutting or grinding operation:

1. Secure the workpiece in a vise.
2. Remove all combustibles, flammable materials, and ignition hazards from the area.
3. Verify the cutter or grinding bit is free of chips or cracks, and install it if it is safe to use.
4. Put on safety goggles, a face shield, and respirator.
5. Make sure that the grinder trigger is in the fully released position (fully out).
6. Place a few drops of air tool oil into the air supply inlet, and connect the grinder to the air supply.
7. Hold the grinder body with both hands, stabilize your body and hands against a fixed object. Next position the grinding bit next to the workpiece.
8. Slowly press the trigger, and carefully feed the cutter or grinding bit into the workpiece. Apply just enough force to remove material while maintaining a high tool RPM.
 - If tool hop or vibration makes the grinder hard to control, adjust the throttle valve screw (see **Figure 1**) to reduce grinder RPM.
9. When finished, or if leaving the area, disconnect the grinder from air, and store it away from children.

SECTION 4: ACCESSORIES

G8210—50-Pc. Stone Set

A great selection of high-quality grinding stones in the most common shapes for detailed die-grinding work. Stones are equipped with 1/4" mounting shanks.

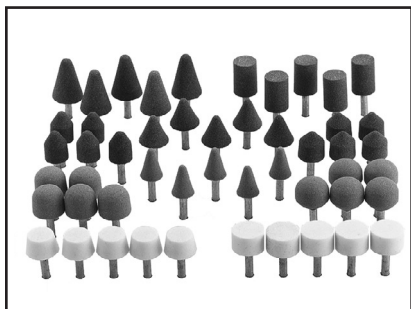

Figure 4. 50-Pc. stone set.

H7573—2" Mini Clamp Vise

This small vise mounts to any work surface up to 1 1/8" thick with its sturdy C-clamp mounting mechanism. Other features include V-groove jaws for holding tubing and round stock, 7/8" x 1 1/2" anvil face and alloy steel construction. Maximum jaw opening is 2".

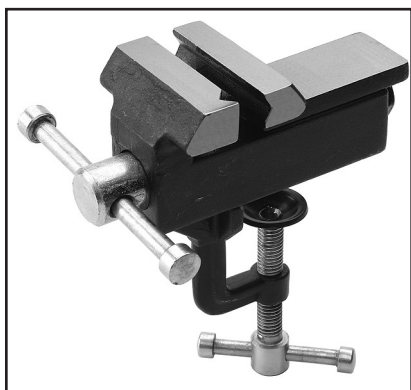

Figure 5. Mini clamp vise.

T20881—In-Line Lubricator 1/4" NPT

T20887—Pressure Regulator 1/4" NPT

G6261—Water Filter 1/4" NPT

Install an in-line lubricator to apply oil automatically. Install an air regulator right at the tool for precise air control. Install a filter in your air supply line to prevent water from traveling into your expensive air tools, and ruining them.

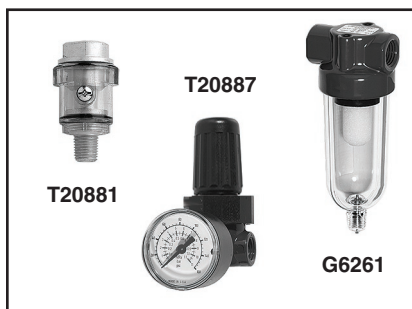

Figure 6. In-line pneumatic accessories.

T20554—Compressor Oil 32 Oz

T20555—Tool Oil 8 Oz

This Porter Cable air compressor and tool oil offers outstanding heat displacement and friction reduction without eating away at O-rings and other rubber components like detergent motor oils.



Figure 7. Air tool oil.

Call 1-800-523-4777 To Order

H3105—Clamp Style Magnifying Lamp
 Mount this lamp to your work table or machine stand for highly detailed viewing. Spring-loaded parallelogram arm design provides full adjustability. Magnifying power is 1.75 times. Great for close-up grinding. Includes two 9 watt bulbs.



Figure 8. Illuminated magnifying.

H0736—Shop Fox® Safety Glasses
H7194—Bifocal Safety Glasses 1.5
H7195—Bifocal Safety Glasses 2.0
H7196—Bifocal Safety Glasses 2.5
T20502—Face Shield Crown Protector
T20503—Face Shield Window
T20451—"Kirova" Clear Safety Glasses
T20452—"Kirova" Anti-Reflective Safety Glasses

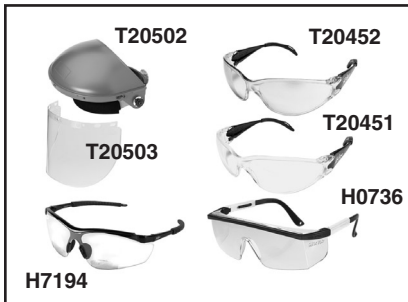

Figure 9. Eye protection assortment.

T20928—Nuisance Dust Mask
T21767—Smart Mask
G7870—Half Mask Respirator: Oil / Organic Vapor
G7871—Particulate Filter
G7872—Filter Retainer
G7866—Particulate Respirator
G7867—Particulate Respirator w/Valve

These maintenance-free Half Mask Respirators come completely and permanently assembled with cartridges so they're ready to use. Each features a soft, lightweight elastomeric face piece, cradle suspension, easy-adjust head straps and low profile for greater field of vision with use of eyeglasses or goggles. The particulate respirators have custom-designed shapes, nosepieces and head straps for superior fit and have collapse resistant, double-shell construction. The T21767 smart mask is individually packaged and features a large 3D-cup shape for better fit and 40% less breathing resistance.



Figure 10. Personal air filtration.

Call 1-800-523-4777 To Order

SECTION 5: MAINTENANCE

⚠️ WARNING



EYE INJURY HAZARD!
Wear safety goggles with full eye protection from all sides when using or servicing this grinder.

Daily Maintenance

Before and after each use:

- Check for leaking or cracked air fittings; bubbled, cut, or worn hoses; and replace as required.
- Place a few drops of air tool oil (not motor oil) in the air inlet fitting.
- Drain the air supply compressor tank and the water filter separator reservoirs.
- Make sure the trigger lock is operational and that the collet holds the tooling tightly. Verify that the collet nut and insert are free of cracks and wear.

Periodically as required:

- Remove the quick disconnect fitting and clean the filter screen. See **Figure 1** on **Page 5** for location.
- Wipe the grinder housing and the shanks of the tool bits with a lightly oiled cloth.
- Check and adjust the automatic in-line oiler.

⚠️ WARNING

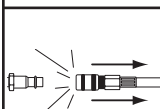

ACCIDENTAL START HAZARD!
Disconnect before service or tool changes.

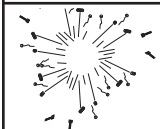

AIR PRESSURE HAZARD!
Never exceed max PSI rating for tool.

Lubrication

In most cases for periodic tool use, manual lubrication is sufficient. However, if the tool is to be used on a consistent basis, we recommend installing an automatic oiler to eliminate dry runs and ensure maximum tool life. The two methods are explained below.

Manual Lubrication: Every two hours of use, place a few drops of air tool oil in the air inlet fitting and at all pivot points. Do not use motor oil as the additives can corrode the tool seals. Next, connect the tool to the air line and cover the exhaust port (see **Figure 1**, on **Page 5**) with a rag. Position the end of the tool safely away from you, and run the tool for 30 seconds to completely circulate the oil through the tool and into the rag.

Automatic Lubrication: Adjust the automatic in-line oiler. Place a sheet of paper next to the exhaust port, run the tool at three or four 30-second intervals. When finished, the paper should show a slight oil stain. If no oil is seen or excessive oil drips from the paper, adjust the oiler and repeat this process until the adjustment is correct. See **Figure 3** for location.

SECTION 6: SERVICE

Troubleshooting

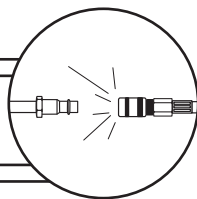

IMPORTANT: Air tool repairs must be completed by a qualified service person.

Symptom	Possible Cause	Solution
Tool runs at normal speed but bogs down when grinding, or tool runs slowly with little air exiting the exhaust.	<ol style="list-style-type: none">1. Grinder is being overloaded.2. Tool adjustment at fault.3. Trigger or lock is bent and binding the trigger.4. Intake filter screen is clogged.5. Insufficient air supply volume or pressure.6. Tool shank or collet insert is worn, causing tool to slip inside collet.7. Incorrect lubrication is affecting tool.8. Water is entering tool.9. Air tool motor clogged with an oil-water sludge.	<ol style="list-style-type: none">1. Reduce feed pressure; install a new or a smaller diameter bit.2. Re-adjust the throttle valve screw to the fully open position.3. Bend the trigger lock or trigger back into position so the trigger fully depresses the throttle valve.4. Clean the filter screen behind the air supply fitting (see Figure 1, on Page 5).5. Set the regulator to 90 PSI, or 100 PSI if the air hose is longer than 25 feet. Repair any leaking fittings, remove all restrictions and hose kinks. Ensure that all hoses and lines have an inside diameter of at least $\frac{3}{8}$".6. Replace worn items. If cutting wheel is used, verify mounting arbor is tight.7. Make sure tool is lubricated correctly and does not run dry. Prevent oil from flooding the air tool by re-adjusting the automatic oiler.8. Service or reposition the air filter water separator as far as possible from the compressor. This allows for maximum air cooling and water condensation for the water separator.9. Clean or rebuild the air tool as required, and correct moisture or lubrication problem in the air supply system.

Symptom	Possible Cause	Solution
Tool does not operate when the trigger is pressed, but air runs freely from exhaust.	1. Motor is at fault.	1. Motor may be stuck in position from improper storage. Lubricate the air tool and rotate spindle by hand a few times. Next use the trigger to operate the air tool while re-oiling several times in the process to flush the tool.
Tool runs slowly, and only a small amount of air exits from the exhaust port.	1. Air regulator or tool adjustment is at fault. 2. Trigger throttle valve is obstructed. 3. Intake filter screen is clogged. 4. Motor loaded with moisture or oil sludge.	1. Adjust the air regulator to 90 PSI, or 100 PSI if the air hose is longer than 25 feet. Re-adjust the throttle valve screw to the fully open position. 2. Disassemble the throttle valve and clean out sludge and contaminants. 3. Clean the filter screen behind the air supply fitting (see Figure 1 , on Page 5). 4. Disassemble air tool, clean, and relubricate. Lubricate air tool and rotate spindle by hand a few times. Next use the trigger to operate the air tool, re-oiling several times in the process to flush the system.
Tool does not shut OFF when trigger is released.	1. Trigger bent or throttle valve at fault. 2. Throttle valve stuck open.	1. Bend trigger back to its normal position so throttle valve is free to return to fully released or OFF position. 2. Replace throttle valve spring or O-rings.
Air tool becomes hot or noisy during operation.	1. Air tool heats up from insufficient lubrication or a worn bearing.	1. Repair air tool, and correct in-line oiler lubrication adjustment, or follow manual lubrication requirements.
Air tool becomes too cold to hold, or ice crystals form at exhaust port.	1. The intake of moisture and the pressure drop is causing moisture to freeze in the tool.	1. Keep compressor tank drained, service, reposition, or add additional water separators in the supply system.

SECTION 7: PARTS

Main Parts Diagram

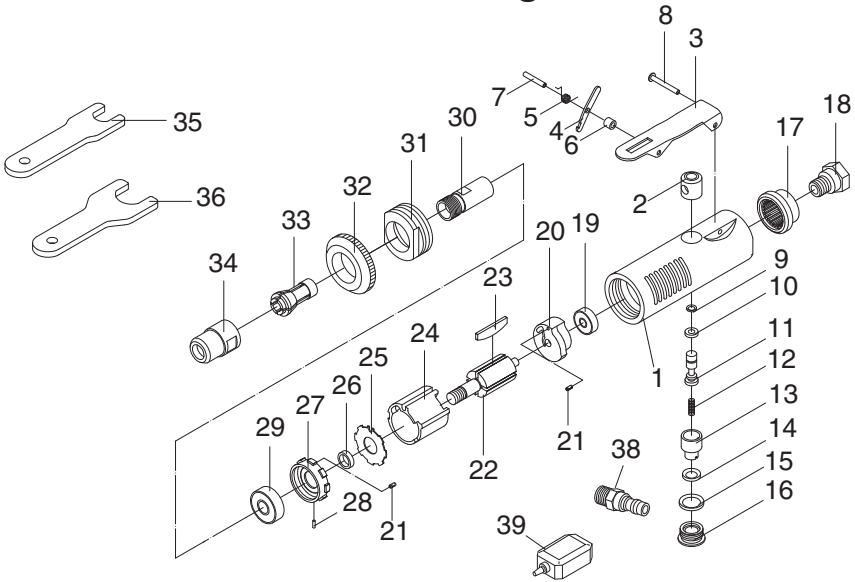

Main Parts List

REF	PART #	DESCRIPTION
1	N/A	HOUSING
2	N/A	THROTTLE VALVE CYLINDER
3	N/A	TRIGGER
4	N/A	TRIGGER LOCK
5	N/A	TORSION SPRING
6	N/A	SPACER
7	PRP01M	ROLL PIN 4 X 18MM
8	N/A	CLEVIS PIN 3 X 22MM
9	N/A	O-RING 3.3 X 1.5MM
10	N/A	O-RING 4 X 22MM
11	N/A	VALVE STEM
12	N/A	COMPRESSION SPRING
13	N/A	REGULATOR
14	N/A	O-RING 7 X 2MM
15	N/A	O-RING 11 X 2MM
16	N/A	THREADED RETAINER
17	N/A	EXHAUST MUFFLER
18	N/A	SCREENED FITTING
19	P626Z	BALL BEARING 626 Z

REF	PART #	DESCRIPTION
20	N/A	ENDPLATE
21	N/A	LOCK PIN 2 X 6MM
22	N/A	ROTOR
23	N/A	VANE SET
24	N/A	CYLINDER
25	N/A	THRUST WASHER
26	N/A	BUSHING
27	N/A	FRONT COVER
28	N/A	LOCK PIN 1.5 X 4MM
29	P608Z	BALL BEARING 608 Z
30	N/A	COLLET SEAT
31	N/A	LOCK RING
32	N/A	RUBBER BUMPER
33	N/A	COLLET INSERT 1/4"
34	N/A	COLLET NUT
35	N/A	SPINDLE WRENCH 1/2"
36	N/A	COLLET WRENCH 11/16"
37	N/A	OIL BOTTLE
38	N/A	QUICK DISCONNECT 1/4"

*Parts breakdown provided for reference only.
Not all parts shown are available for purchase.*

WARRANTY

Grizzly Industrial, Inc. warrants every product it sells for a period of **1 year** to the original purchaser from the date of purchase. This warranty does not apply to defects due directly or indirectly to misuse, abuse, negligence, accidents, repairs or alterations or lack of maintenance. This is Grizzly's sole written warranty and any and all warranties that may be implied by law, including any merchantability or fitness, for any particular purpose, are hereby limited to the duration of this written warranty. We do not warrant or represent that the merchandise complies with the provisions of any law or acts unless the manufacturer so warrants. In no event shall Grizzly's liability under this warranty exceed the purchase price paid for the product and any legal actions brought against Grizzly shall be tried in the State of Washington, County of Whatcom.

We shall in no event be liable for death, injuries to persons or property or for incidental, contingent, special, or consequential damages arising from the use of our products.

To take advantage of this warranty, contact us by mail or phone and give us all the details. We will then issue you a "Return Number," which must be clearly posted on the outside as well as the inside of the carton. We will not accept any item back without this number. Proof of purchase must accompany the merchandise.

The manufacturers reserve the right to change specifications at any time because they constantly strive to achieve better quality equipment. We make every effort to ensure that our products meet high quality and durability standards and we hope you never need to use this warranty.

Please feel free to write or call us if you have any questions about the machine or the manual.

Thank you again for your business and continued support. We hope to serve you again soon.

Free Manuals Download Website

<http://myh66.com>

<http://usermanuals.us>

<http://www.somanuals.com>

<http://www.4manuals.cc>

<http://www.manual-lib.com>

<http://www.404manual.com>

<http://www.luxmanual.com>

<http://aubethermostatmanual.com>

Golf course search by state

<http://golfingnear.com>

Email search by domain

<http://emailbydomain.com>

Auto manuals search

<http://auto.somanuals.com>

TV manuals search

<http://tv.somanuals.com>