

# Grizzly

**Industrial, Inc.** ®

## MODEL H8126 WIDE WHEEL GRINDER OWNER'S MANUAL



COPYRIGHT © JANUARY, 2007 BY GRIZZLY INDUSTRIAL, INC.  
**WARNING: NO PORTION OF THIS MANUAL MAY BE REPRODUCED IN ANY SHAPE  
OR FORM WITHOUT THE WRITTEN APPROVAL OF GRIZZLY INDUSTRIAL, INC.**  
#BL8859 PRINTED IN CHINA

# **WARNING!**

**This manual provides critical safety instructions on the proper setup, operation, maintenance and service of this machine/equipment.**

**Failure to read, understand and follow the instructions given in this manual may result in serious personal injury, including amputation, electrocution or death.**

**The owner of this machine/equipment is solely responsible for its safe use. This responsibility includes but is not limited to proper installation in a safe environment, personnel training and usage authorization, proper inspection and maintenance, manual availability and comprehension, application of safety devices, blade/cutter integrity, and the usage of personal protective equipment.**

**The manufacturer will not be held liable for injury or property damage from negligence, improper training, machine modifications or misuse.**

# **WARNING!**

**Some dust created by power sanding, sawing, grinding, drilling, and other construction activities contains chemicals known to the State of California to cause cancer, birth defects or other reproductive harm. Some examples of these chemicals are:**

- **Lead from lead-based paints.**
- **Crystalline silica from bricks, cement and other masonry products.**
- **Arsenic and chromium from chemically-treated lumber.**

**Your risk from these exposures varies, depending on how often you do this type of work. To reduce your exposure to these chemicals: Work in a well ventilated area, and work with approved safety equipment, such as those dust masks that are specially designed to filter out microscopic particles.**

# Table of Contents

<b>INTRODUCTION.....</b>	<b>2</b>
Foreword .....	2
Contact Info.....	2
Data Sheet .....	3
Identification .....	4
<b>SECTION 1: SAFETY .....</b>	<b>5</b>
Safety Instructions for Machinery.....	5
Additional Safety Instructions for Grinders.....	7
<b>SECTION 2: CIRCUIT REQUIREMENTS .....</b>	<b>8</b>
110V Operation .....	8
<b>SECTION 3: SET UP .....</b>	<b>9</b>
Set Up Safety .....	9
Items Needed for Setup .....	9
Unpacking .....	9
Inventory.....	10
Hardware Recognition Chart.....	11
Site Considerations .....	12
Mounting.....	12
Tool Rest and Eye Shield .....	13
Test Run.....	14
<b>SECTION 4: OPERATIONS .....</b>	<b>15</b>
Operation Safety .....	15
Grinding Tips.....	15
Wheel Care .....	16
Wheel Selection .....	16
Wheel Inspection.....	17
Wheel Dressing.....	17
Wheel Replacement.....	17
<b>SECTION 5: ACCESSORIES .....</b>	<b>19</b>
<b>SECTION 6: MAINTENANCE .....</b>	<b>20</b>
Schedule .....	20
Grinding Wheels.....	20
Maintenance Log.....	21
<b>SECTION 7: SERVICE .....</b>	<b>22</b>
Troubleshooting.....	22
Wiring Diagram .....	23
Parts Breakdown.....	24
Parts List .....	25
<b>WARRANTY AND RETURNS .....</b>	<b>26</b>

# INTRODUCTION

---

---

## Foreword

---

---

We are proud to offer the Model H8126 Wide Wheel Grinder. This machine is part of a growing Grizzly family of fine woodworking and metalworking machinery. When used according to the guidelines set forth in this manual, you can expect years of trouble-free, enjoyable operation and proof of Grizzly's commitment to customer satisfaction.

The specifications, drawings, and photographs illustrated in this manual represent the Model H8126 when the manual was prepared. However, owing to Grizzly's policy of continuous improvement, changes may be made at any time with no obligation on the part of Grizzly.

For your convenience, we always keep current Grizzly manuals available on our website at **www.grizzly.com**. Any updates to your machine will be reflected in these manuals as soon as they are complete. Visit our site often to check for the latest updates to this manual!

## Contact Info

---

---

If you have any comments regarding this manual, please write to us at the address below:

Grizzly Industrial, Inc.  
c/o Technical Documentation Manager  
P.O. Box 2069  
Bellingham, WA 98227-2069  
Email: manuals@grizzly.com

We stand behind our machines. If you have any service questions or parts requests, please call or write us at the location listed below.

Grizzly Industrial, Inc.  
1203 Lycoming Mall Circle  
Muncy, PA 17756  
Phone: (570) 546-9663  
Fax: (800) 438-5901  
E-Mail: techsupport@grizzly.com  
Web Site: <http://www.grizzly.com>





# MACHINE DATA SHEET

Customer Service #: (570) 546-9663 • To Order Call: (800) 523-4777 • Fax #: (800) 438-5901

## MODEL H8126 WIDE WHEEL GRINDER

Design Type ..... Bench Model

### Overall Dimensions:

Height ..... 9"  
 Width ..... 14"  
 Depth ..... 8½"  
 Shipping Weight ..... 20 lbs.  
 Net Weight ..... 18¾ lbs.  
 Box Size ..... 9½" D x 13" W x 9" H  
 Footprint ..... 14" W x 8½" D  
 Arbor Diameter ..... ½"  
 Wheel Size ..... 6" Dia. x (½" to ¾" W) and 6" Dia x (¾" to 1½" W)  
 Wheel Type ..... Type 1

### Motor:

Type ..... TEFC Capacitor-Start Induction  
 Horsepower ..... ¼ HP  
 Phase / Voltage ..... Single-Phase / 110V  
 Amps ..... 2.5A  
 Cycle / RPM ..... 60 Hertz / 1725 RPM  
 Bearings ..... Shielded & Permanently Lubricated

### Features:

..... Wheel Flanges  
 ..... Rocker-Type Switch  
 ..... Included 36 Grit Aluminum Oxide Grinding Wheel  
 ..... Included 100 Grit Aluminum Oxide Grinding Wheel

*Specifications, while deemed accurate, are not guaranteed.*



# Identification

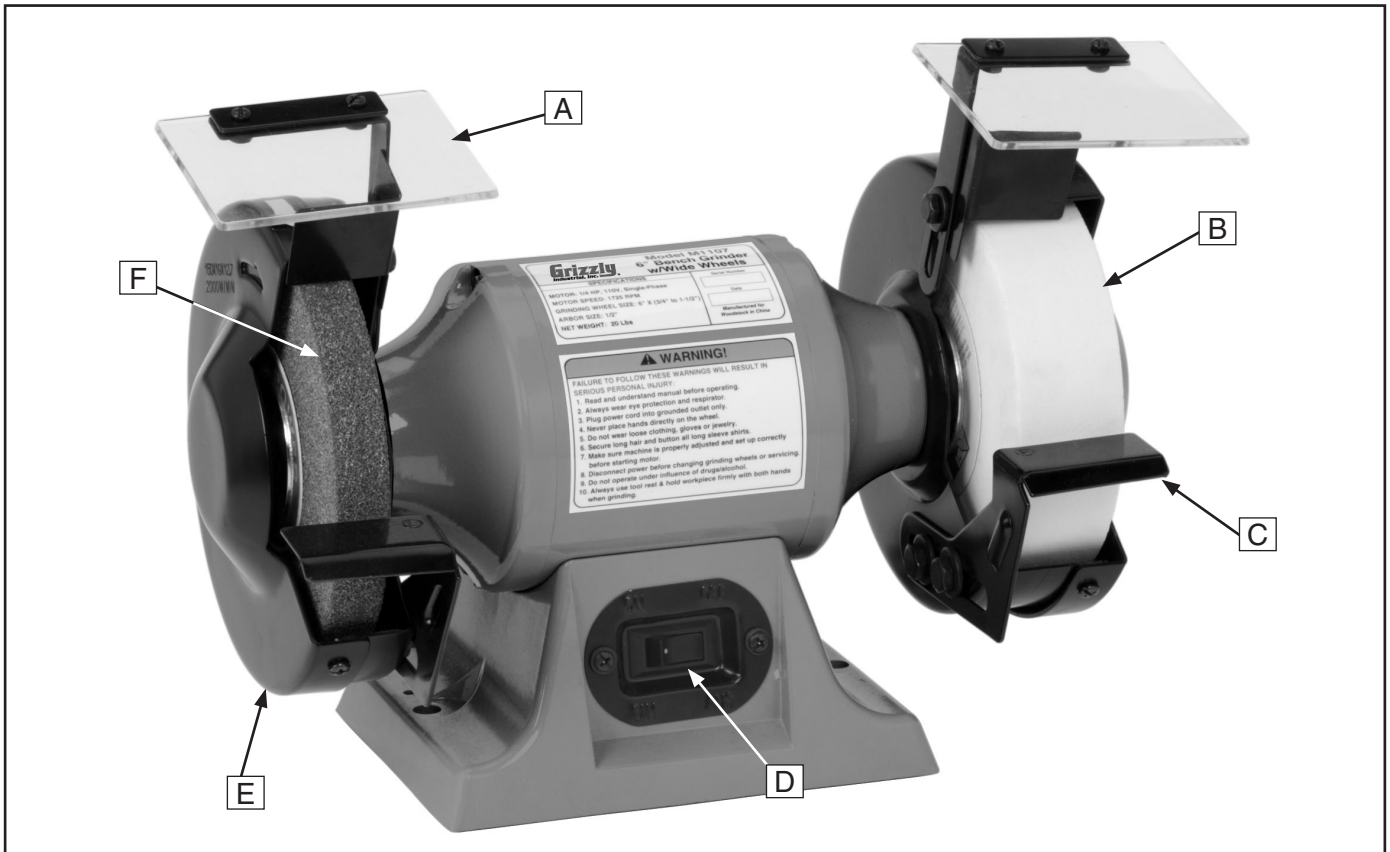

Figure 1. Model H8126 identification.

- A. Eye Shield (to be used WITH safety glasses)
- B. Wide Grinding Wheel, 100 Grit
- C. Tool Rest
- D. ON/OFF Switch
- E. Wheel Safety Guard
- F. Regular Grinding Wheel, 36 Grit



# SECTION 1: SAFETY

## WARNING

### For Your Own Safety, Read Instruction Manual Before Operating this Machine

The purpose of safety symbols is to attract your attention to possible hazardous conditions. This manual uses a series of symbols and signal words intended to convey the level of importance of the safety messages. The progression of symbols is described below. Remember that safety messages by themselves do not eliminate danger and are not a substitute for proper accident prevention measures.



Indicates an imminently hazardous situation which, if not avoided, **WILL** result in death or serious injury.



Indicates a potentially hazardous situation which, if not avoided, **COULD** result in death or serious injury.



Indicates a potentially hazardous situation which, if not avoided, **MAY** result in minor or moderate injury. It may also be used to alert against unsafe practices.

**NOTICE**

This symbol is used to alert the user to useful information about proper operation of the machine.

## WARNING

### Safety Instructions for Machinery

- 1. READ THE ENTIRE MANUAL BEFORE STARTING MACHINERY.** Machinery presents serious injury hazards to untrained users.
- 2. ALWAYS USE ANSI APPROVED SAFETY GLASSES WHEN OPERATING MACHINERY.** Everyday eyeglasses only have impact resistant lenses—they are NOT safety glasses.
- 3. ALWAYS WEAR A NIOSH APPROVED RESPIRATOR WHEN OPERATING MACHINERY THAT PRODUCES DUST.** Wood dust can cause severe respiratory illnesses.
- 4. ALWAYS USE HEARING PROTECTION WHEN OPERATING MACHINERY.** Machinery noise can cause permanent hearing loss.
- 5. WEAR PROPER APPAREL. DO NOT** wear loose clothing, gloves, neckties, rings, or jewelry that can catch in moving parts. Wear protective hair covering to contain long hair and wear non-slip footwear.
- 6. NEVER OPERATE MACHINERY WHEN TIRED OR UNDER THE INFLUENCE OF DRUGS OR ALCOHOL.** Be mentally alert at all times when running machinery.



# WARNING

## Safety Instructions for Machinery

7. **ONLY ALLOW TRAINED AND PROPERLY SUPERVISED PERSONNEL TO OPERATE MACHINERY.** Make sure operation instructions are safe and clearly understood.
8. **KEEP CHILDREN AND VISITORS AWAY.** Keep all children and visitors a safe distance from the work area.
9. **MAKE WORKSHOP CHILDPROOF.** Use padlocks, master switches, and remove start switch keys.
10. **NEVER LEAVE WHEN MACHINE IS RUNNING.** Turn power **OFF** and allow all moving parts to come to a complete stop before leaving machine unattended.
11. **DO NOT USE IN DANGEROUS ENVIRONMENTS.** DO NOT use machinery in damp, wet locations, or where any flammable or noxious fumes may exist.
12. **KEEP WORK AREA CLEAN AND WELL LIGHTED.** Clutter and dark shadows may cause accidents.
13. **USE A GROUNDED EXTENSION CORD RATED FOR THE MACHINE AMPERAGE.** Grounded cords minimize shock hazards. Undersized cords create excessive heat. Always replace damaged extension cords.
14. **ALWAYS DISCONNECT FROM POWER SOURCE BEFORE SERVICING MACHINERY.** Make sure switch is in OFF position before reconnecting.
15. **MAINTAIN MACHINERY WITH CARE.** Keep blades sharp and clean for best and safest performance. Follow instructions for lubricating and changing accessories.
16. **MAKE SURE GUARDS ARE IN PLACE AND WORK CORRECTLY BEFORE USING MACHINERY.**
17. **REMOVE ADJUSTING KEYS AND WRENCHES.** Make a habit of checking for keys and adjusting wrenches before turning machinery **ON**.
18. **CHECK FOR DAMAGED PARTS BEFORE USING MACHINERY.** Check for binding or misaligned parts, broken parts, loose bolts, and any other conditions that may impair machine operation. Repair or replace damaged parts before operation.
19. **USE RECOMMENDED ACCESSORIES.** Refer to the instruction manual for recommended accessories. Improper accessories increase risk of injury.
20. **DO NOT FORCE MACHINERY.** Work at the speed for which the machine or accessory was designed.
21. **SECURE WORKPIECE.** Use clamps or a vise to hold the workpiece when practical. A secured workpiece protects your hands and frees both hands to operate the machine.
22. **DO NOT OVERREACH.** Maintain stability and balance at all times.
23. **MANY MACHINES CAN EJECT WORKPIECES TOWARD OPERATOR.** Know and avoid conditions that cause the workpiece to "kickback."
24. **ALWAYS LOCK MOBILE BASES (IF USED) BEFORE OPERATING MACHINERY.**
25. **CERTAIN DUST MAY BE HAZARDOUS** to the respiratory systems of people and animals, especially fine dust. Be aware of the type of dust you are exposed to and always wear a respirator designed to filter that type of dust.





## **WARNING**

# Additional Safety Instructions for Grinders

- 1. EYE PROTECTION.** Grinding causes small particles to become airborne at a high rate of speed. **ALWAYS** wear safety glasses when using this machine.
- 2. MOUNTING TO BENCH/STAND.** An unsecured grinder may become dangerously out of control during operation. Make sure grinder is **FIRMLY** secured to a bench/stand before use.
- 3. WHEEL SPEED RATING.** Wheels operated at a faster speed than rated for may break or fly apart. Before mounting a new wheel, be sure the wheel RPM rating is equal to or higher than the speed of the grinder.
- 4. WHEEL FLANGES.** Only use the flanges included with the grinder when mounting wheels. Other flanges may not properly secure the wheel and cause an accident.
- 5. RING TEST.** Perform a “ring test” on grinding wheels before installation to ensure that they are safe to use. A wheel that does not pass the ring test may break or fly apart during operation.
- 6. STARTING GRINDER.** If a wheel IS damaged, it will usually fly apart shortly after start-up. To protect yourself, always stand to the side of the grinder when turning it **ON**, allow it to gain full speed and wait for at least 1 minute before standing in front of it.
- 7. LUNG PROTECTION.** Grinding produces hazardous dust, which may cause long-term respiratory problems if inhaled. Always wear a NIOSH approved dust mask or respirator when grinding.
- 8. SIDE GRINDING.** Grinding on the side of wheels can cause them to break and fly apart—unless the wheel is rated for side grinding.
- 9. TOP GRINDING.** Grinding on the top of wheels greatly increases the risk of workpiece kickback. Always grind on the downward part of the wheel.
- 10. HAND/WHEEL CONTACT.** Grinding wheels have the capability of removing a lot of skin fast. Keep a firm grip on the workpiece and position your hands a safe distance away when grinding. Avoid wearing gloves as they may get caught in the grinding wheel and cause even more serious entanglement injuries.
- 11. TOOL REST POSITION.** If the tool rest is too far away from the wheel, the workpiece may be pulled down, causing loss of control and pulling your hand into the grinding wheel. Keep the tool rest within  $\frac{1}{8}$ " from the wheel when operating.

## **WARNING**

Like all machinery there is potential danger when operating this machine. Accidents are frequently caused by lack of familiarity or failure to pay attention. Use this machine with respect and caution to lessen the possibility of operator injury. If normal safety precautions are overlooked or ignored, serious personal injury may occur.

## **CAUTION**

No list of safety guidelines can be complete. Every shop environment is different. Always consider safety first, as it applies to your individual working conditions. Use this and other machinery with caution and respect. Failure to do so could result in serious personal injury, damage to equipment, or poor work results.



# SECTION 2: CIRCUIT REQUIREMENTS

## 110V Operation

### **!WARNING**

Serious personal injury could occur if you connect the machine to the power source before you have completed the set up process. **DO NOT** connect the machine to the power source until instructed to do so.

### Amperage Draw

The Model H8126 motor draws the following amps under maximum load:

Motor Draw .....2.5 Amps

### Circuit Recommendations

We recommend connecting your machine to a dedicated and grounded circuit that is rated for the amperage given below. Never replace a circuit breaker on an existing circuit with one of higher amperage without consulting a qualified electrician to ensure compliance with wiring codes. **If you are unsure about the wiring codes in your area or you plan to connect your machine to a shared circuit, consult a qualified electrician.**

110V Circuit..... 15 Amps

### Plug/Receptacle Type

Included Plug Type..... NEMA 5-15

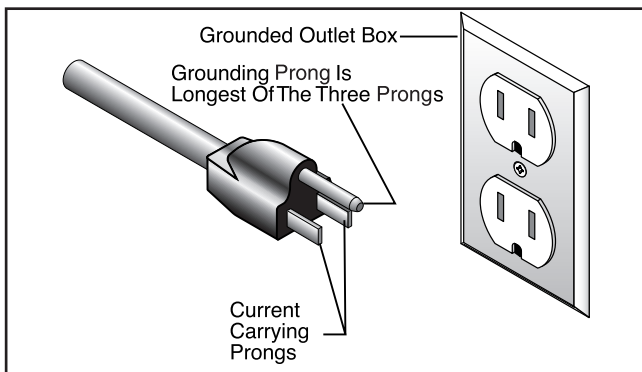

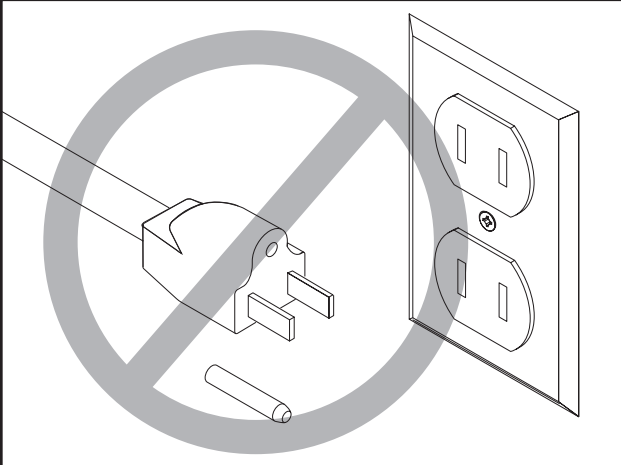

Figure 2. Typical type 5-15 plug and receptacle.



### **!WARNING**

Electrocution or fire could result if this machine is not grounded correctly or if your electrical configuration does not comply with local and state codes. Ensure compliance by checking with a qualified electrician!



### **!CAUTION**

This machine must have a ground prong in the plug to help ensure that it is grounded. **DO NOT** remove ground prong from plug to fit into a two-pronged outlet! If the plug will not fit the outlet, have the proper outlet installed by a qualified electrician.

### Extension Cords

We do not recommend the use of extension cords, but if you find it absolutely necessary:

- Use at least a 16 gauge cord that does not exceed 50 feet in length!
- The extension cord must also contain a ground wire and plug pin.
- A qualified electrician **MUST** size cords over 50 feet long to prevent motor damage.



# SECTION 3: SET UP

## Set Up Safety

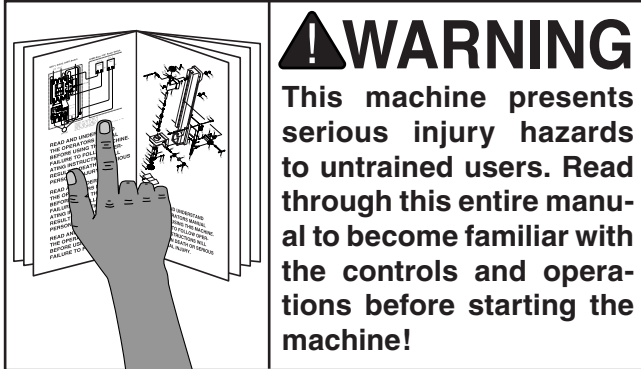

## Items Needed for Setup

The following items are needed to complete the setup process, but are not included with your machine:

Description	Qty
• Safety Glasses (for each person) .....	1
• Wrench $\frac{7}{16}$ " .....	1
• Wrench $1\frac{1}{32}$ " .....	1
• Wrench $\frac{1}{2}$ " .....	1
• Phillips Head Screwdriver #2 .....	1

## Unpacking

The Model H8126 was carefully packed when it left our warehouse. If you discover the machine is damaged after you have signed for delivery, *please immediately call Customer Service at (570) 546-9663 for advice.*

Save the containers and all packing materials for possible inspection by the carrier or its agent. *Otherwise, filing a freight claim can be difficult.*

When you are completely satisfied with the condition of your shipment, inventory the contents.



# Inventory

After all the parts have been removed from the box, you should have the following items:

<b>Box Contents: (Figures 3 &amp; 4)</b>	<b>Qty</b>
<b>A.</b> Wide Wheel Grinder (Not Shown).....	1
<b>B.</b> Left Spark Guard .....	1
Right Spark Guard (Not Shown) .....	1
<b>C.</b> Eye Shields .....	2
<b>D.</b> Nut Plates.....	2
<b>E.</b> Bracket .....	2
<b>F.</b> Left Tool Rest .....	1
Right Tool Rest (Not Shown) .....	1
<b>G. Hardware and Tools (Not Shown):</b>	<b>Qty</b>
—Hex Bolts 1/4"-20 x 3/8" (Eye Shield).....	2
—Phillip Head Screws 8-32 x 3/8" (Eye Shield) .....	4
—Flat Washers 4mm (Eye Shield).....	4
—Hex Nuts #8-32 (Eye Shield).....	4
—Flat Washers 1/4" (Eye shield).....	2
—Flat Washers 5/16" (Tool Rest).....	4
—Hex Bolts 5/16"-18 x 3/8" (Tool Rest) .....	4

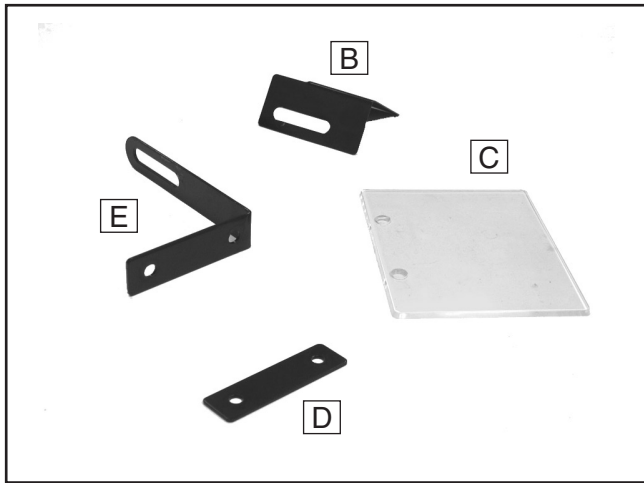

**Figure 3.** Left eye shield assembly.

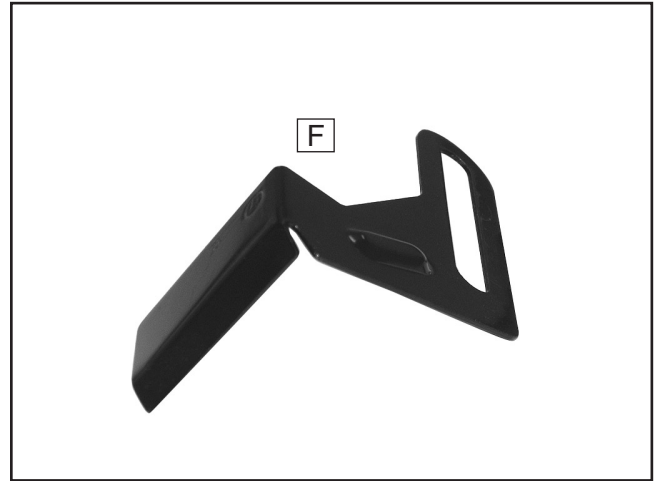

**Figure 4.** Left tool rest.

If any nonproprietary parts are missing (e.g. a nut or a washer), we will gladly replace them; or for the sake of expediency, replacements can be obtained at your local hardware store.

## ***NOTICE***







**Some hardware/fasteners on the inventory list may arrive pre-installed. Check mounting locations before assuming that any items from the inventory list are missing.**









# Hardware Recognition Chart

USE THIS CHART TO MATCH UP HARDWARE DURING THE ASSEMBLY PROCESS.

MEASURE BOLT DIAMETER BY PLACING INSIDE CIRCLE

-  #10
-  1/4"
-  5/16"
-  3/8"
-  7/16"
-  1/2"

-  4mm
-  6mm
-  8mm
-  10mm
-  12mm
-  16mm

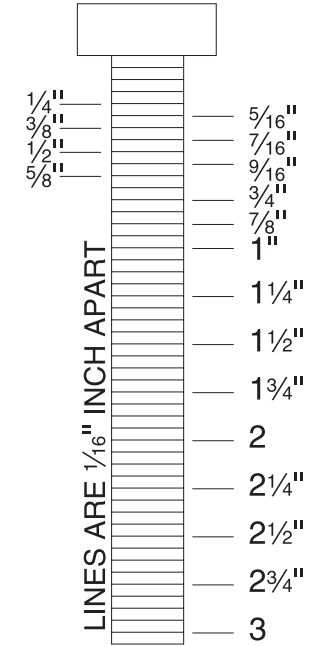
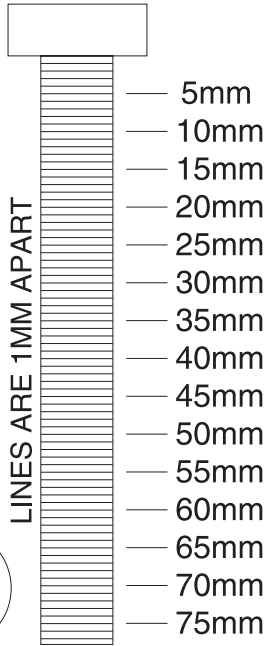
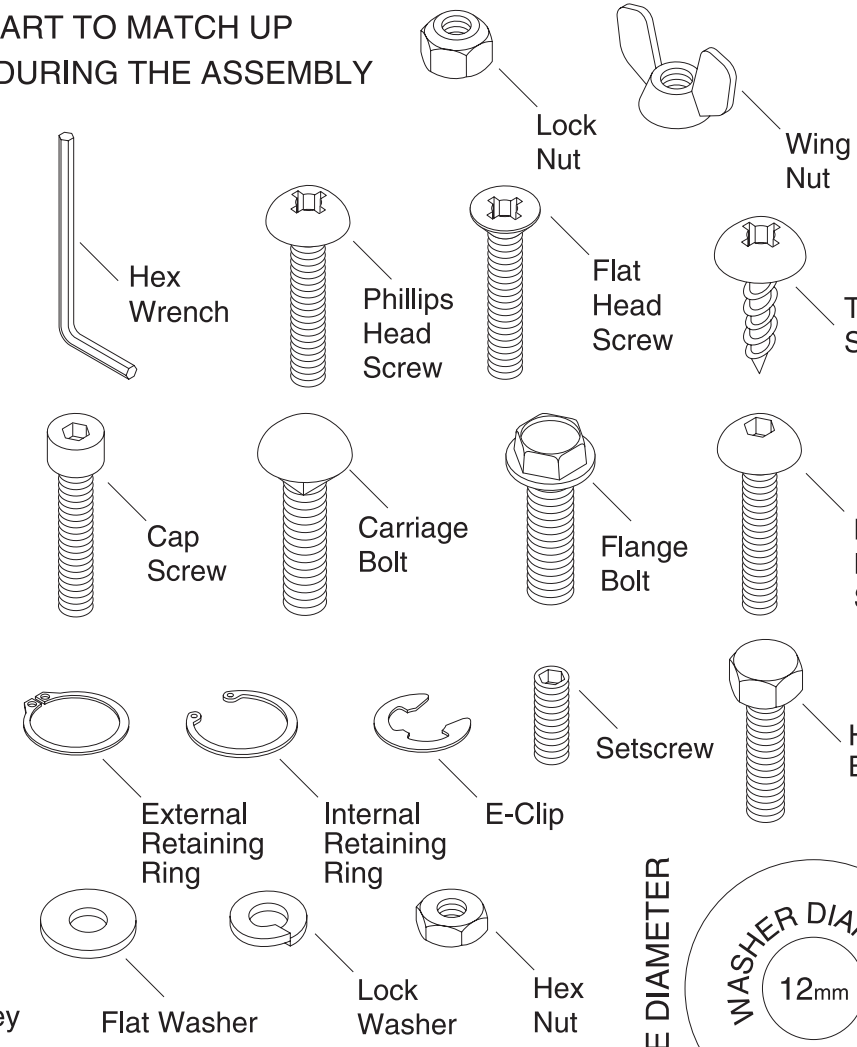

WASHERS ARE MEASURED BY THE INSIDE DIAMETER

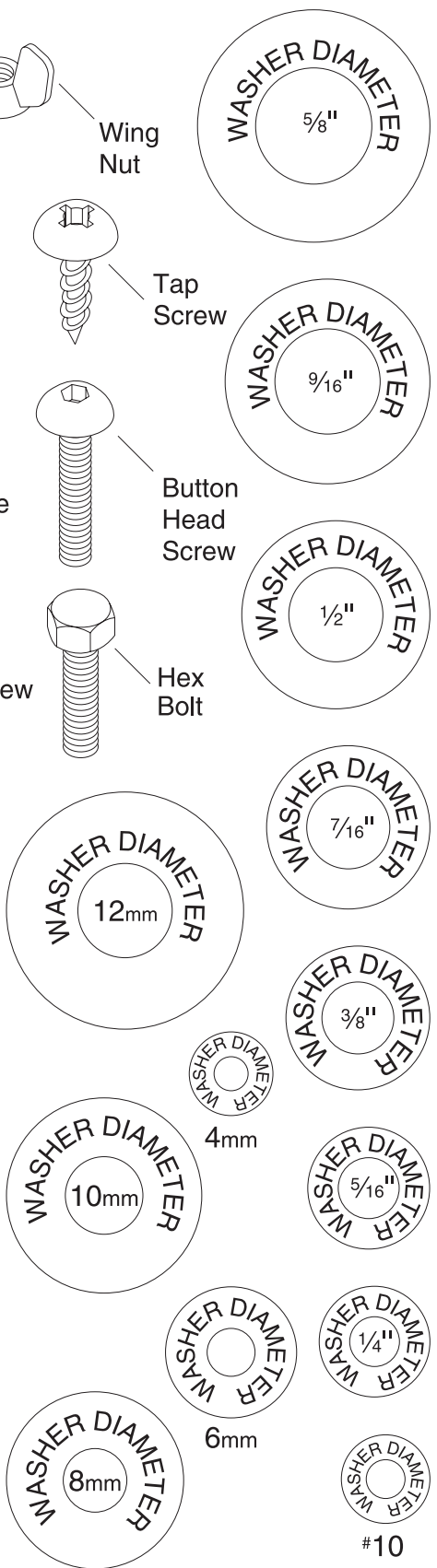

# Site Considerations

## Bench Load

Refer to the **Machine Data Sheet** for the weight and footprint specifications of your machine. Some workbenches may require additional reinforcement to support both the machine and the workpiece.

## Placement Location

Consider existing and anticipated needs, size of material to be processed through each machine, and space for auxiliary stands, work tables or other machinery when establishing a location for your new machine. See **Figure 5** for the minimum working clearances.

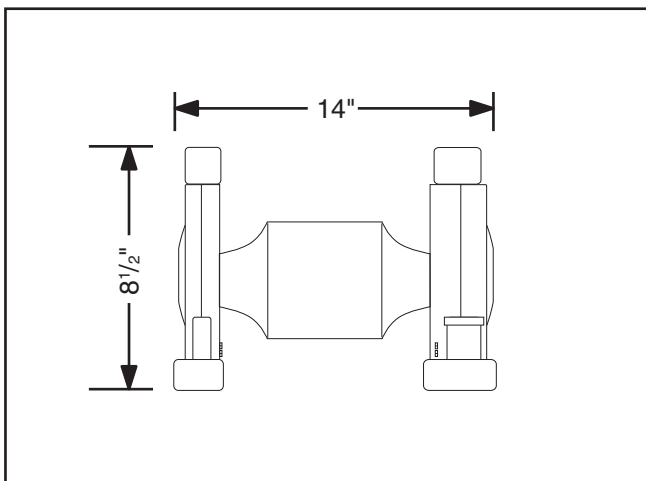

**Figure 5.** Minimum working clearances.

	<p><b>⚠ CAUTION</b></p> <p>Children and visitors may be seriously injured if unsupervised. Lock all entrances to the shop when you are away. <b>DO NOT</b> allow unsupervised children or visitors in your shop at any time!</p>
---	--

# Mounting

The Model H8126 must be mounted to a workbench to avoid accidental tipping. If you intend to use the grinder for portable applications, mount it to a heavy plywood base (at least 1" thick) that is wide enough to prevent tipping or rocking during use, then clamp the plywood base to the workbench or table.

## To mount the grinder:

1. Once you have confirmed that your grinder is running properly, mount it to a workbench through the holes in the base using the dimensions in **Figure 6**. **DO NOT** overtighten the mounting bolts or you will crack the base.

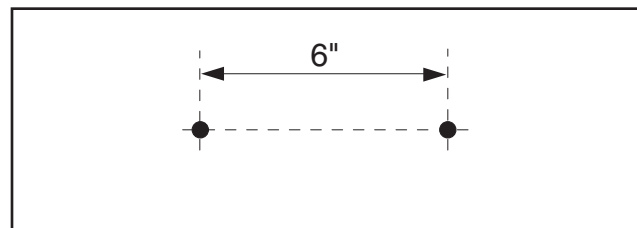

**Figure 6.** Bench grinder mounting bolt pattern.



The strongest mounting option is a "Through Mount" where holes are drilled all the way through the workbench, and hex bolts, washers, and hex nuts are used to secure the grinder to the workbench.

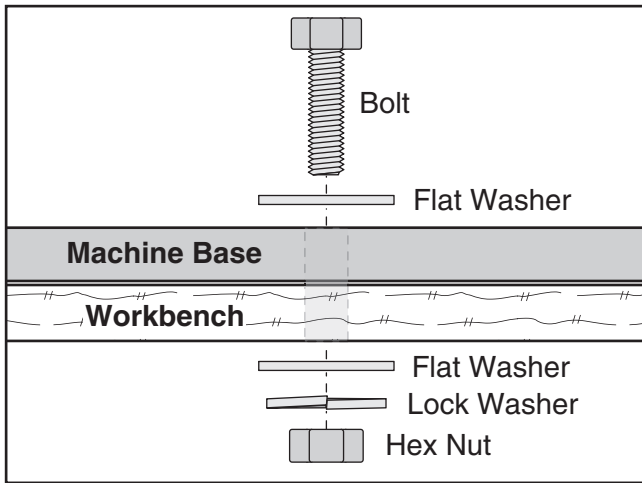

**Figure 7.** Example of a through mount setup.

Another option for mounting is a "Direct Mount" where the machine is simply secured to the workbench with a lag screw.

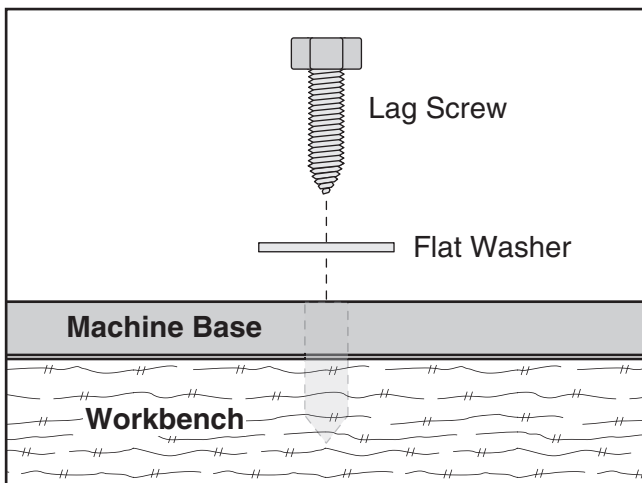

**Figure 8.** Example of a direct mount setup.

2. Check the stability of the mounted grinder to make sure it is stable.
3. Always make sure the grinder is bolted or clamped to the workbench, table, or grinder stand before use.

## Tool Rest and Eye Shield

The tool rest supports the workpiece during grinding. Jigs or accessories may be attached to the tool rest to grind the workpiece at complex angles.

The eye shield must be installed and positioned between the grinding wheel and your face during grinding. The eye shield is NOT a substitute for safety glasses or a safety face shield. You must wear ANSI approved face and eye protection.

### To assemble the tool rest and eye shield:

1. Using the hardware from the inventory list on **Page 10**, assemble the left tool rest and eye shield as shown in **Figures 9 & 10**.

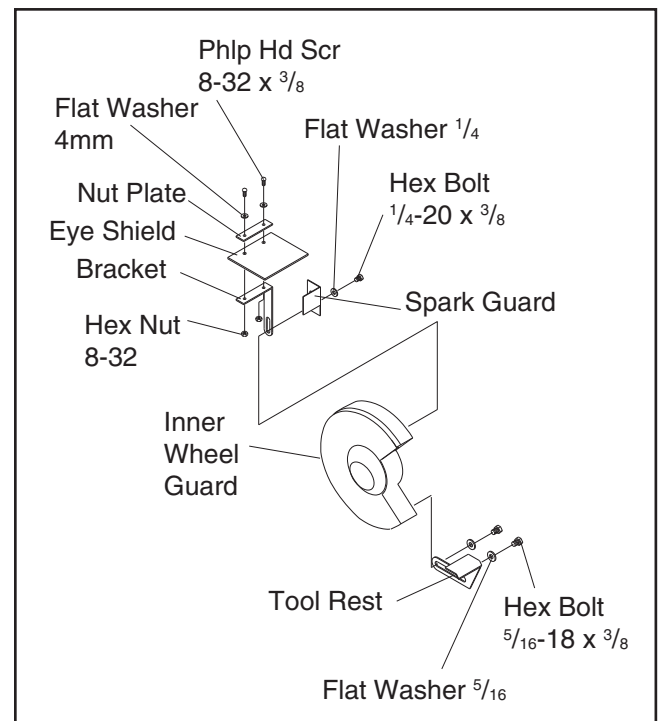

**Figure 9.** Left eye shield and tool rest assembly.



# Test Run

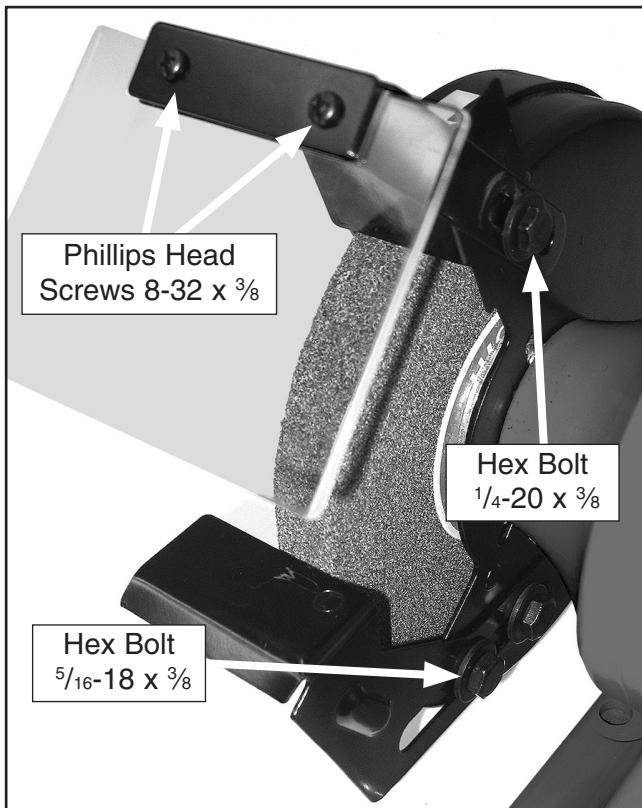

**Figure 10.** Left tool rest and eye shield assembly.

2. Assemble the right tool rest and eye shield in the same manner.

When your machine is mounted and assembly is complete, test run your machine to make sure it runs properly.

If, during the test run, you cannot easily locate the source of an unusual noise or vibration, stop using the machine immediately, review the **Troubleshooting** on **Page 22**, and correct the problem.

If you cannot remedy a problem, contact our Tech Support at (570) 546-9663 for assistance.

## To test run the machine:

1. Make sure you have read the safety instructions at the beginning of the manual and that the grinder is setup properly.
2. Make sure the switch is in the OFF position.
3. Connect the grinder to the power source.
4. Make sure all tools and objects used during set up are cleared away from the grinder.
5. Turn the grinder **ON**. Keep your hand poised over the switch in case you need to quickly turn the machine **OFF**.
6. Listen to and watch for abnormal noises. Under normal conditions, the grinder will hum or vibrate little.  
  
—Investigate the cause of unusual noises and eliminate them before operating the machine further. Always disconnect the machine from power before investigating or correcting potential problems.
7. Turn the grinder **OFF**.





# SECTION 4: OPERATIONS

## Operation Safety

### **!WARNING**

Damage to your eyes, lungs, and ears could result from using this machine without proper protective gear. Always wear safety glasses, a respirator, and hearing protection when operating this machine.

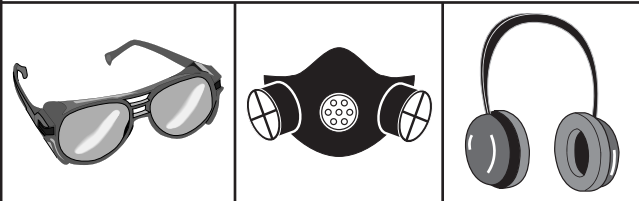

### **!WARNING**

Loose hair and clothing could get caught in machinery and cause serious personal injury. Keep loose clothing and long hair away from moving machinery.

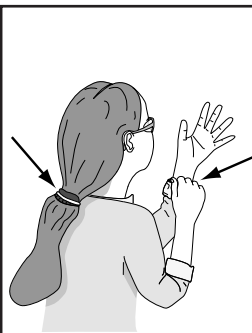

### **!WARNING**

**DO NOT** use this grinder with a liquid cooling system required for wet grinding wheel operations. The electrical system is not waterproof. Ignoring this warning can lead to electrocution.

### **NOTICE**

If you have never used this type of machine or equipment before, **WE STRONGLY RECOMMEND** that you read books, trade magazines, or get formal training before beginning any projects. Regardless of the content in this section, Grizzly Industrial will not be held liable for accidents caused by lack of training.

## Grinding Tips

The grinder is a safe tool when used properly. In addition to the safety instructions in this manual, the most important safety consideration is to use common sense at all times. What may be okay in one situation, can be dangerous in another.

**Here are some tips to keep in mind while grinding:**

- Make sure all guards are in place.
- Remember that grinding often produces sparks. **DO NOT** allow anyone to stand in the path of the sparks.
- **DO NOT** grind near flammable materials.
- Maintain proper care of your wheels. Read the **Wheel Care** instructions on **Page 16** for ideas on how to do this.
- Wear the proper protective clothing. Particles flying off of a grinding wheel will be traveling very fast—prepare for this. Wear safety glasses/face shield, a dust mask, earplugs, a leather apron, and heavy leather boots.
- Grasp the workpiece firmly and properly support it on the tool rest during grinding. Maintain even pressure and control of the workpiece when grinding.
- Concentrate on the task at hand. **STOP** grinding if other people are distracting you or your mind is on something else.
- **DO NOT** grind on the side of the wheel. The wheels provided with the Model H8126 are not designed for side grinding.



# Wheel Care

Your safety when grinding depends, in large part, on the condition of the wheel. A wheel in poor condition may break apart during rotation, injuring the operator and damaging property.

## Here are some tips to help you avoid breaking the wheel:

- Always transport, store and handle wheels with care. Wheels may be damaged if they are dropped or if heavy objects are stacked on them.
- Select the right grinding wheel for the job. DO NOT grind material inappropriate for the wheel type.
- Select the right wheel for the machine. If a grinding wheel rotates faster than its RPM rating, it may fly apart.
- Mount wheels properly. (See the **Wheel Replacement** instructions on **Page 17** for guidance.) Never use a wheel with the wrong arbor size for the grinder.
- Do not abuse the wheel by jamming the work into the grinding wheel with excessive force.
- Learn how to use the grinder and the grinding wheels properly. Ask a trusted person with experience or consult with your local library to learn more.
- Do not store wheels in damp or wet locations.
- Grinding on the side of the wheel may cause wheel damage.
- Replace wheels when the diameter becomes 2" smaller than its original size.

# Wheel Selection

The Model H8126 only accepts Type 1 wheels with a 1/2" bore.

Aluminum oxide and silicon carbide wheels are marked in a somewhat uniform manner by all major manufacturers. Understanding these markings will help you understand the capabilities of various wheels. Always refer to the manufacturer's grinding recommendations when selecting a wheel for your project.

## The basic format for wheel numbering is:

Prefix	Abrasive Type	Grit Size	Grade	Bond Type
1	A	60	L	V

The **Prefix** is the manufacturer's designation for a particular wheel type (eg, Type 1 wheels).

The most common **Abrasive Types** used are 'A' for Aluminum Oxide, 'C' for Silicon Carbide, and occasionally 'SG' for Seeded Gel.

The **Grit Size** is a number that refers to the size of the abrasive grain in the wheel. The lower the number, the coarser the wheel. Ten is a very coarse wheel for roughing and 220 is usually the upper range for fine finish work.

**Grade** is an indication of the hardness of the wheel—'A' being the softest and 'Z' being the hardest.

**Bond Type** refers to the type of bonding material used to hold the abrasive material. Most general purpose wheels will have a 'V' indicating Vitrified Clay is used. Vitrified Clay provides high strength and good porosity. The other common bond type is 'B' for resin where synthetic resins are used. These are used to grind cemented carbide and ceramic materials.

**Note:** *There may be other numbers inserted that have meaning for a particular type of wheel. Refer to the manufacturer's technical data for a complete explanation.*



# Wheel Inspection

Do not assume that a wheel is in sound condition just because it is new—often damage can occur in shipping, with age, or with exposure to moisture. Inspect every wheel for damage.

First, do a **Visual Inspection**. Look for any cracks, chips, nicks or dents in the surface of the wheel. If you see any of these, **DO NOT** use the wheel.

Second, do a **Ring Test**, by following **Steps 1-5** below. This test will give you an indication of any internal damage that may not be obvious during a visual inspection.

Always be sure to use a wheel that is rated for 3450 RPM or greater.

## To perform a Ring Test:

1. Make sure the wheel that you test is clean and dry; otherwise, you may get false results.
2. If size permits, balance the wheel with your finger in the hole. If this is not possible, hang the wheel in the air with a piece of cord or string looped through the hole in the center.
3. At the spots shown in **Figure 11**, gently tap the wheel with a light non-metallic device such as the handle of a screwdriver or a wooden mallet.

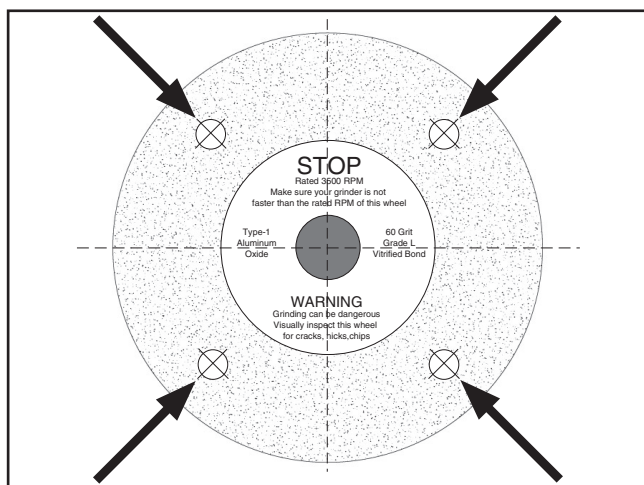

**Figure 11.** Tapping locations when performing a ring test.

4. An undamaged wheel will emit a clear metallic ring or “ping” sound in each of these spots. A damaged wheel will respond with a dull thud that has no clear tone.
5. If you determine from the ring test that the wheel is damaged, **DO NOT** use it!

# Wheel Dressing

Depending on the type of grinding you do, the grinding wheel may require periodic dressing.

Several different kinds of wheel dressing devices are available (see **Page 19**). Dressing restores the abrasive quality of the wheel surface and squares up the wheel edge.

Refer to the instructions that accompany your dressing accessory for complete details on how to properly dress a wheel.

# Wheel Replacement

The wheel guard assembly must be removed in order to mount or dismount a grinding wheel.

## To replace a grinding wheel:

1. **DISCONNECT THE GRINDER FROM POWER!**
2. Remove the three Phillips head screws and nuts that go through the outer guard, and remove the outer guard.
3. Block the wheel from turning, then remove the arbor nut that secures the wheel.

**Note:** *The arbor shaft and nut on the left side of the grinder (as you face front) has left hand threads; to loosen this nut, turn it clockwise.*

4. Remove the outer wheel flange and the paper disc. Pull the wheel free from the arbor, but leave the paper disc and a wheel flange on the other side of the wheel.

## **CAUTION**

**NEVER** assemble a grinding wheel on the arbor without paper or fiber discs between the wheel and the flange. Omitting the discs can put uneven stress on the wheel, causing it to crack and possibly fly apart. **ALWAYS** "ring test" a wheel before assembly to make certain it has no cracks or flaws.

5. Mount the new wheel as shown in **Figure 12**. Always make certain there is a paper or fiber disc between the wheel flanges and the wheel itself. Tighten the arbor nut snugly but **DO NOT** over-tighten. Over-tightening can crack the wheel.

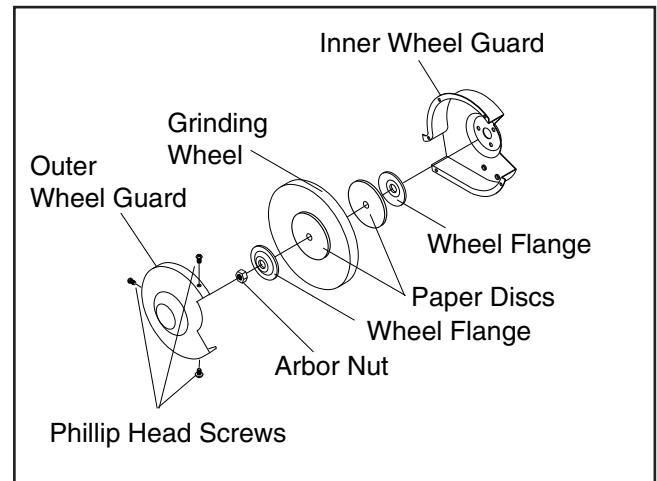

**Figure 12.** Typical assembly order for wheel installation.

6. Run a new wheel for at least one minute while standing clear of the line of rotation. If a wheel does have defects it will generally fail as soon as it gets up to full speed.

# SECTION 5: ACCESSORIES

## G7120—Heavy Duty Grinder Stand

This is one of the most stable bench grinder stands on the market. Once you have one, you'll wonder how you ever got along without it. 32½" high. Universal mounting plate may require modifications for some bench grinders. Buffer/Sander not included. 49 lbs.



Figure 13. Model G7120.

## H5891—½ Carat Diamond Dresser

## H5892—¾ Carat Diamond Dresser

Industrial diamond for dressing grinding wheels. 8¼" long round body with knurled grip for maximum control. Includes protective rubber end cap.

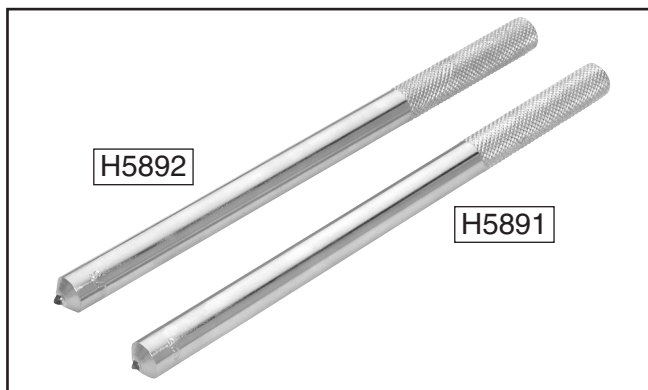

Figure 14. Diamond Dressers.

## Type 1 Aluminum Oxide Replacement Wheels

G1979—6" Wheel, 36 Grit, ½ Bore

G1980—6" Wheel, 60 Grit, ½ Bore

## G7984—Face Shield

H1298—Dust Sealed Safety Glasses

H1300—UV Blocking, Clear Safety Glasses

H2347—Uvex® Spitfire Safety Glasses

H0736—Shop Fox® Safety Glasses

Safety Glasses are essential to every shop. If you already have a pair, buy extras for visitors or employees. You can't be too careful when it comes to shop safety!

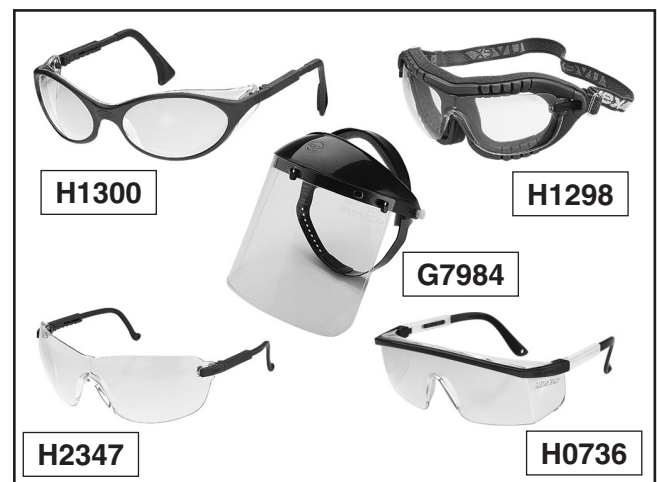

Figure 15. Our most popular safety glasses.

**Call 1-800-523-4777 To Order**

# SECTION 6: MAINTENANCE

---

---

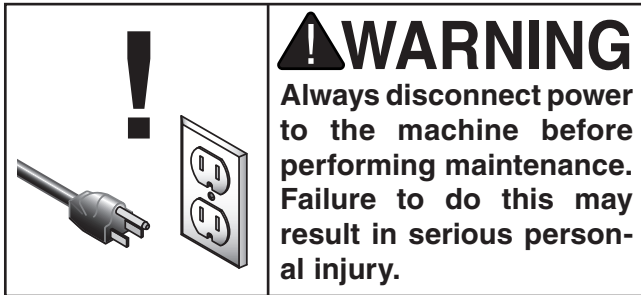

## Schedule

---

For optimum performance from your machine, follow this maintenance schedule and refer to any specific instructions given in this section. Routinely check the condition of the following items and repair or replace as necessary:

- Cracked or loose grinding wheel.
- Loose mounting bolts.
- Worn switch.
- Worn or damaged cords and plugs.
- Any other condition that could hamper the safe operation of this machine.

## Grinding Wheels

---

---

The grinding wheel should be inspected before every use. Use the ring test method noted in **Wheel Inspection** on **Page 17** to verify the structural integrity. Take care in storing grinding wheels to keep them free from potential damage by being dropped or having other items drop on them.

Replace the wheel when the wheel diameter is reduced to 2" smaller than its original size. Operating at anything less than this diameter does not allow the proper surface speed for grinding or spacing of the tool rest and the eye shield, and the grinding wheel may fly apart.







# SECTION 7: SERVICE

Review the troubleshooting and procedures in this section to fix or adjust your machine if a problem develops. If you need replacement parts or you are unsure of your repair skills, then feel free to call our Technical Support at (570) 546-9663.

## Troubleshooting

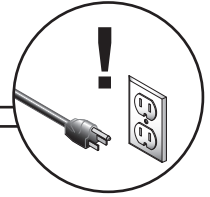

### Motor & Electrical

Symptom	Possible Cause	Possible Solution
Motor will not start; fuses or circuit breakers blow.	<ol style="list-style-type: none"> <li>1. Switch is at fault.</li> <li>2. Open circuit in motor or loose connections.</li> <li>3. Incorrect fuses or circuit breakers in power supply.</li> <li>4. Start capacitor is at fault.</li> <li>5. Short circuit in motor or loose connections.</li> </ol>	<ol style="list-style-type: none"> <li>1. Replace switch.</li> <li>2. Inspect/repair all lead connections on motor for loose or open connections.</li> <li>3. Install correct fuses or circuit breakers.</li> <li>4. Replace start capacitor.</li> <li>5. Inspect all connections on motor for loose or shorted terminals or worn insulation.</li> </ol>
Motor overheats, stalls (resulting in blown fuses or tripped circuit).	<ol style="list-style-type: none"> <li>1. Motor overloaded.</li> <li>2. Short circuit in motor or loose connections.</li> </ol>	<ol style="list-style-type: none"> <li>1. Slow down feed rate of workpiece.</li> <li>2. Inspect connections on motor for loose or shorted terminals or worn insulation.</li> </ol>

### Grinder Operations

Symptom	Possible Cause	Possible Solution
Wavy condition on surface of workpiece.	<ol style="list-style-type: none"> <li>1. Machine vibrating.</li> <li>2. Wheel face uneven.</li> <li>3. Workpiece is not held in place firmly.</li> <li>4. Wheel is too hard.</li> </ol>	<ol style="list-style-type: none"> <li>1. Make sure machine is securely mounted on a solid surface.</li> <li>2. Dress the grinding wheel.</li> <li>3. Use a holding device to firmly retain the workpiece.</li> <li>4. Use softer wheel, or reduce the feed rate.</li> </ol>
Lines on surface of workpiece.	<ol style="list-style-type: none"> <li>1. Impurity on wheel surface.</li> <li>2. Workpiece not being held tightly.</li> </ol>	<ol style="list-style-type: none"> <li>1. Dress the grinding wheel.</li> <li>2. Use a holding device to firmly retain the workpiece.</li> </ol>
Burning spots or cracks in the workpiece.	<ol style="list-style-type: none"> <li>1. Improper type of grinding wheel.</li> <li>2. Improper feed rate.</li> </ol>	<ol style="list-style-type: none"> <li>1. Try a wheel that is softer style or a coarser grit.</li> <li>2. Slow down the rate of movement of the workpiece into wheel.</li> </ol>
Wheel dulls quickly, grit falls off.	<ol style="list-style-type: none"> <li>1. Depth of cut too great.</li> <li>2. Wheel is too soft.</li> <li>3. Wheel diameter too small.</li> <li>4. Bad wheel dress.</li> </ol>	<ol style="list-style-type: none"> <li>1. Slow down the rate of movement of the workpiece into wheel.</li> <li>2. Wheel too soft for the material being ground, select harder bond.</li> <li>3. Replace the wheel.</li> <li>4. Dress the wheel.</li> </ol>
Wheel clogs and workpiece shows burn marks.	<ol style="list-style-type: none"> <li>1. Wheel is too hard.</li> <li>2. Feed rate too slow.</li> <li>3. Bad wheel dress.</li> <li>4. Wrong material is being ground.</li> </ol>	<ol style="list-style-type: none"> <li>1. Wheel too hard for the material being ground, select softer bond.</li> <li>2. Increase the rate of movement of the workpiece into wheel.</li> <li>3. Dress the wheel.</li> <li>4. Grind ferrous metals only.</li> </ol>





# Wiring Diagram

**Grizzly**  
Industrial, Inc.

**⚠ DANGER**  
Disconnect power before performing any electrical service. Electricity presents serious shock hazards that will result in severe personal injury and even death!

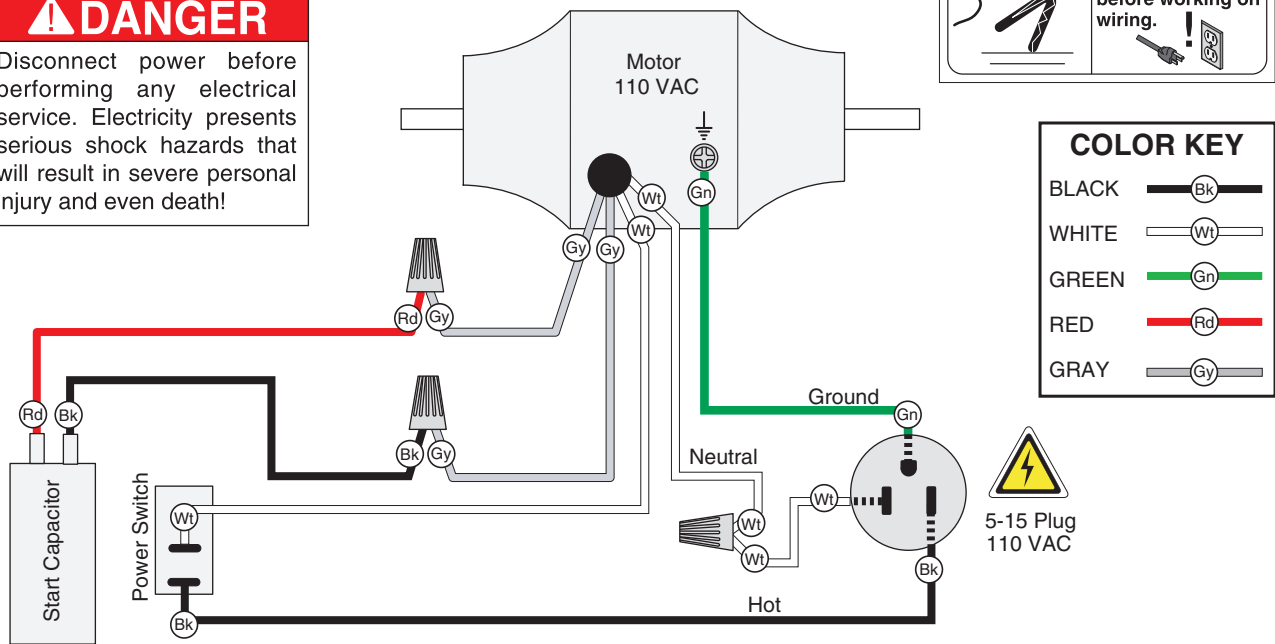

**COLOR KEY**

BLACK	
WHITE	
GREEN	
RED	
GRAY	



5-15 Plug  
110 VAC

 This wiring diagram can be viewed online in color at [www.grizzly.com](http://www.grizzly.com).



Figure 16. H8126 Wiring.



# Parts Breakdown

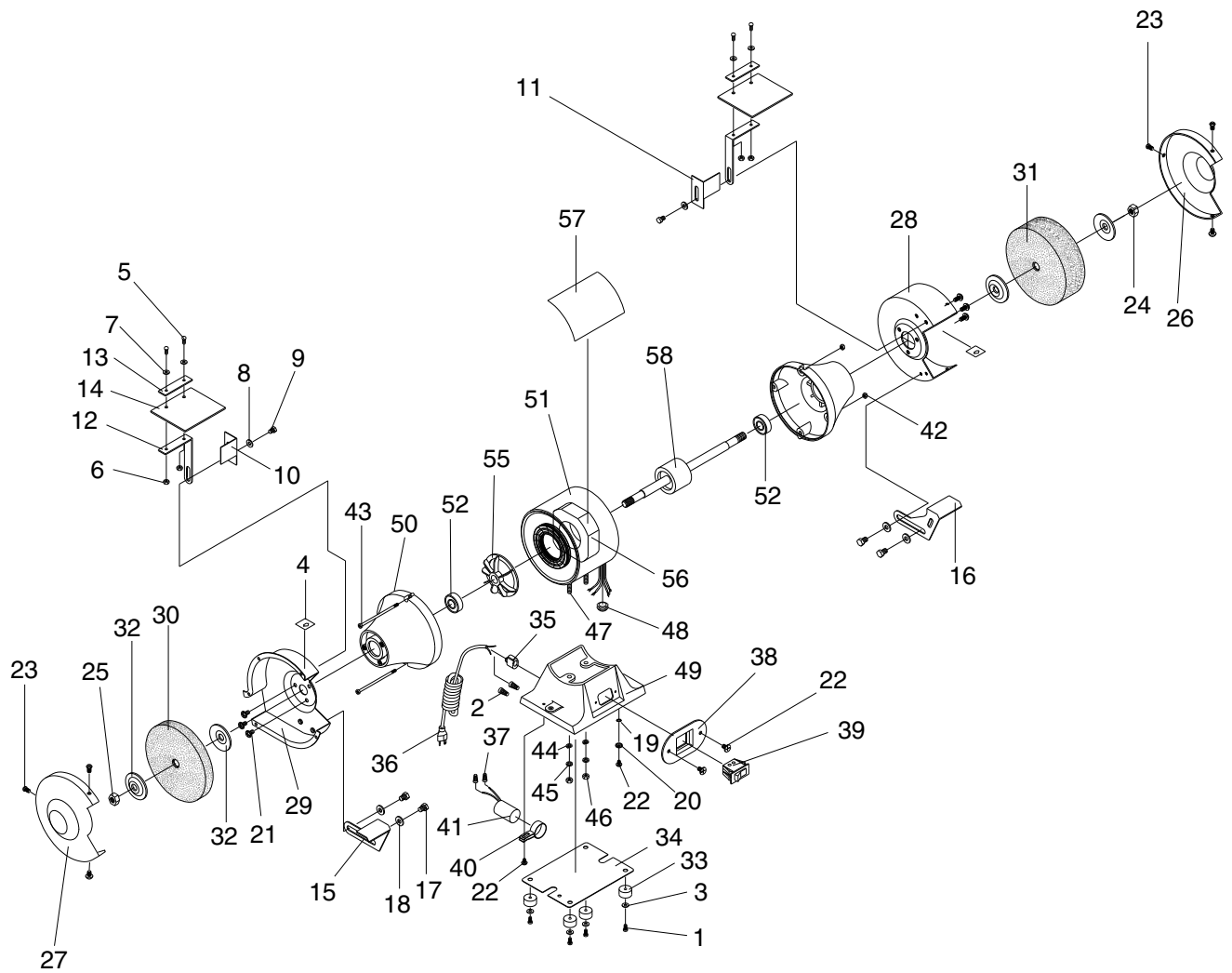

# Parts List

REF	PART #	DESCRIPTION
1	PS06	PHLP HD SCR 10-24 X 3/8
2	PH8126002	WIRE NUT
3	PW02M	FLAT WASHER 5MM
4	PH8126004	ARROW LABEL
5	PS24	PHLP HD SCR 8-32 X 3/8
6	PN14	HEX NUT 8-32
7	PW05M	FLAT WASHER 4MM
8	PW06	FLAT WASHER 1/4
9	PB51	HEX BOLT 1/4-20 X 3/8
10	PH8126010	LEFT SPARK GUARD
11	PH8126011	RIGHT SPARK GUARD
12	PH8126012	BRACKET
13	PH8126013	NUT PLATE
14	PH8126014	EYE SHIELD
15	PH8126015	LEFT TOOL REST
16	PH8126016	RIGHT TOOL REST
17	PB15	HEX BOLT 5/16-18 X 3/8
18	PW07	FLAT WASHER 5/16
19	PLW01M	LOCK WASHER 5MM
20	PH8126020	COPPER WASHER 5MM
21	PH8126021	SPECIAL TOOTH SCR 1/4-20 X 3/8
22	PH8126022	SPECIAL TOOTH SCR 10-24 X 1/4
23	PS18	PHLP HD SCR 10-24 X 1/4
24	PH8126024	RIGHT 1/2" ARBOR NUT
25	PH8126025	LEFT 1/2" ARBOR NUT
26	PH8126026	RIGHT OUTER WHEEL GUARD
27	PH8126027	LEFT OUTER WHEEL GUARD
28	PH8126028	RIGHT INNER WHEEL GUARD
29	PH8126029	LEFT INNER WHEEL GUARD

REF	PART #	DESCRIPTION
30	PH8126030	GRAY GRINDING WHEEL #36
31	PH8126031	WHITE GRINDING WHEEL #100
32	PH8126032	WHEEL FLANGE
33	PH8126033	RUBBER FOOT
34	PH8126034	BOTTOM PLATE
35	PH8126035	STRAIN RELIEF
36	PH8126036	110V POWER CORD
37	PH8126037	WIRE NUT
38	PH8126038	SWITCH PLATE
39	PH8126039	ROCKER SWITCH SW-155-BB2
40	PH8126040	CAPACITOR RETAINER
41	PH8126041	CAPACITOR 6MFD 250VAC
42	PN07	HEX NUT 10-24
43	PH8126043	PHLP HD SCR 10-24 X 4-1/4
44	PW06	FLAT WASHER 1/4
45	PLW02	LOCK WASHER 1/4
46	PN05	HEX NUT 1/4-20
47	PSS06	SET SCREW 1/4-20 X 3/4
48	PH8126048	STRAIN RELIEF
49	PH8126049	BASE
50	PH8126050	END COVER
51	PH8126051	MOTOR CASE
52	P6202	BALL BEARING 6202ZZ
55	PH8126055	FAN
56	PH8126056	STATOR
57	PH8126057	DATA/WARNING LABEL
58	PH8126058	ROTOR AND SHAFT
*59	PPAINT-1	PAINT-GRIZZLY GREEN

\*Not shown on parts diagram.

## WARNING

Safety labels warn about machine hazards and ways to prevent injury. The owner of this machine **MUST** maintain the original location and readability of the labels on the machine. If any label is removed or becomes unreadable, **REPLACE** that label before using the machine again. Contact Grizzly at (800) 523-4777 or [www.grizzly.com](http://www.grizzly.com) to order new labels.



# WARRANTY AND RETURNS

---

Grizzly Industrial, Inc. warrants every product it sells for a period of **1 year** to the original purchaser from the date of purchase. This warranty does not apply to defects due directly or indirectly to misuse, abuse, negligence, accidents, repairs or alterations or lack of maintenance. This is Grizzly's sole written warranty and any and all warranties that may be implied by law, including any merchantability or fitness, for any particular purpose, are hereby limited to the duration of this written warranty. We do not warrant or represent that the merchandise complies with the provisions of any law or acts unless the manufacturer so warrants. In no event shall Grizzly's liability under this warranty exceed the purchase price paid for the product and any legal actions brought against Grizzly shall be tried in the State of Washington, County of Whatcom.

We shall in no event be liable for death, injuries to persons or property or for incidental, contingent, special, or consequential damages arising from the use of our products.

To take advantage of this warranty, contact us by mail or phone and give us all the details. We will then issue you a "Return Number," which must be clearly posted on the outside as well as the inside of the carton. We will not accept any item back without this number. Proof of purchase must accompany the merchandise.

The manufacturers reserve the right to change specifications at any time because they constantly strive to achieve better quality equipment. We make every effort to ensure that our products meet high quality and durability standards and we hope you never need to use this warranty.

Please feel free to write or call us if you have any questions about the machine or the manual.

Thank you again for your business and continued support. We hope to serve you again soon.





# WARRANTY CARD

Name \_\_\_\_\_

Street \_\_\_\_\_

City \_\_\_\_\_ State \_\_\_\_\_ Zip \_\_\_\_\_

Phone # \_\_\_\_\_ Email \_\_\_\_\_ Invoice # \_\_\_\_\_

Model # \_\_\_\_\_ Order # \_\_\_\_\_ Serial # \_\_\_\_\_

The following information is given on a voluntary basis. It will be used for marketing purposes to help us develop better products and services. **Of course, all information is strictly confidential.**

1. How did you learn about us?

- Advertisement
- Card Deck
- Friend
- Website
- Catalog
- Other:

2. Which of the following magazines do you subscribe to?

- |   |  |   |
|---|--|---|
| <input type="checkbox"/> Cabinet Maker          | <input type="checkbox"/> Popular Mechanics   | <input type="checkbox"/> Today's Homeowner    |
| <input type="checkbox"/> Family Handyman        | <input type="checkbox"/> Popular Science     | <input type="checkbox"/> Wood                 |
| <input type="checkbox"/> Hand Loader            | <input type="checkbox"/> Popular Woodworking | <input type="checkbox"/> Wooden Boat          |
| <input type="checkbox"/> Handy                  | <input type="checkbox"/> Practical Homeowner | <input type="checkbox"/> Woodshop News        |
| <input type="checkbox"/> Home Shop Machinist    | <input type="checkbox"/> Precision Shooter   | <input type="checkbox"/> Woodsmith            |
| <input type="checkbox"/> Journal of Light Cont. | <input type="checkbox"/> Projects in Metal   | <input type="checkbox"/> Woodwork             |
| <input type="checkbox"/> Live Steam             | <input type="checkbox"/> RC Modeler          | <input type="checkbox"/> Woodworker West      |
| <input type="checkbox"/> Model Airplane News    | <input type="checkbox"/> Rifle               | <input type="checkbox"/> Woodworker's Journal |
| <input type="checkbox"/> Modeltec               | <input type="checkbox"/> Shop Notes          | <input type="checkbox"/> Other:               |
| <input type="checkbox"/> Old House Journal      | <input type="checkbox"/> Shotgun News        |   |

3. What is your annual household income?

- \$20,000-\$29,000
- \$30,000-\$39,000
- \$40,000-\$49,000
- \$50,000-\$59,000
- \$60,000-\$69,000
- \$70,000+

4. What is your age group?

- 20-29
- 30-39
- 40-49
- 50-59
- 60-69
- 70+

5. How long have you been a woodworker/metalworker?

- 0-2 Years
- 2-8 Years
- 8-20 Years
- 20+ Years

6. How many of your machines or tools are Grizzly?

- 0-2
- 3-5
- 6-9
- 10+

7. Do you think your machine represents a good value?  Yes  No

8. Would you recommend Grizzly Industrial to a friend?  Yes  No

9. Would you allow us to use your name as a reference for Grizzly customers in your area?  
**Note:** We never use names more than 3 times.  Yes  No

10. Comments: \_\_\_\_\_

\_\_\_\_\_  
\_\_\_\_\_

CUT ALONG DOTTED LINE

FOLD ALONG DOTTED LINE

\_\_\_\_\_

\_\_\_\_\_

\_\_\_\_\_



Place  
Stamp  
Here



**GRIZZLY INDUSTRIAL, INC.**  
**P.O. BOX 2069**  
**BELLINGHAM, WA 98227-2069**



FOLD ALONG DOTTED LINE

Send a Grizzly Catalog to a friend:

Name _____
Street _____
City _____ State _____ Zip _____

TAPE ALONG EDGES--PLEASE DO NOT STAPLE



# *grizzly.com*

**TOOL WEBSITE**

Buy Direct and Save with Grizzly® – Trusted, Proven and a Great Value!

*Visit Our Website Today And Discover  
Why Grizzly® Is The Industry Leader!*

- SECURE ORDERING
- ORDERS SHIPPED WITHIN 24 HOURS
- E-MAIL RESPONSE WITHIN ONE HOUR

-OR-

Call Today For A **FREE**  
Full Color Catalog

**1-800-523-4777**





## Free Manuals Download Website

<http://myh66.com>

<http://usermanuals.us>

<http://www.somanuals.com>

<http://www.4manuals.cc>

<http://www.manual-lib.com>

<http://www.404manual.com>

<http://www.luxmanual.com>

<http://aubethermostatmanual.com>

Golf course search by state

<http://golfingnear.com>

Email search by domain

<http://emailbydomain.com>

Auto manuals search

<http://auto.somanuals.com>

TV manuals search

<http://tv.somanuals.com>