

# Grizzly<sup>®</sup>

**Industrial, Inc.**

## MODEL H7758/H7759

### 8" & 10" Grinders

### OWNER'S MANUAL



COPYRIGHT © DECEMBER, 2005 BY GRIZZLY INDUSTRIAL, INC. REVISED APRIL, 2007

**WARNING: NO PORTION OF THIS MANUAL MAY BE REPRODUCED IN ANY SHAPE OR FORM WITHOUT THE WRITTEN APPROVAL OF GRIZZLY INDUSTRIAL, INC.**

#TR7764 PRINTED IN CHINA

 **WARNING!**

**This manual provides critical safety instructions on the proper setup, operation, maintenance and service of this machine/equipment.**

**Failure to read, understand and follow the instructions given in this manual may result in serious personal injury, including amputation, electrocution or death.**

**The owner of this machine/equipment is solely responsible for its safe use. This responsibility includes but is not limited to proper installation in a safe environment, personnel training and usage authorization, proper inspection and maintenance, manual availability and comprehension, application of safety devices, blade/cutter integrity, and the usage of personal protective equipment.**

**The manufacturer will not be held liable for injury or property damage from negligence, improper training, machine modifications or misuse.**

 **WARNING!**

**Some dust created by power sanding, sawing, grinding, drilling, and other construction activities contains chemicals known to the State of California to cause cancer, birth defects or other reproductive harm. Some examples of these chemicals are:**

- **Lead from lead-based paints.**
- **Crystalline silica from bricks, cement and other masonry products.**
- **Arsenic and chromium from chemically-treated lumber.**

**Your risk from these exposures varies, depending on how often you do this type of work. To reduce your exposure to these chemicals: Work in a well ventilated area, and work with approved safety equipment, such as those dust masks that are specially designed to filter out microscopic particles.**

# Table of Contents

<b>INTRODUCTION</b> .....	<b>2</b>
Foreword .....	2
Contact Info .....	2
H7758 Machine Data Sheet .....	3
H7759 Machine Data Sheet .....	4
Identification .....	5
<b>SECTION 1: SAFETY</b> .....	<b>6</b>
Safety Instructions for Machinery .....	6
<b>SECTION 2: CIRCUIT REQUIREMENTS</b> .....	<b>9</b>
110V Operation .....	9
<b>SECTION 3: SET UP</b> .....	<b>10</b>
Set Up Safety .....	10
Items Needed for Set Up .....	10
Unpacking .....	10
Inventory & Assembly .....	11
<b>SECTION 4: OPERATIONS</b> .....	<b>13</b>
Operation Safety .....	13
Wheel Care .....	14
Wheel Selection .....	14
Wheel Inspection.....	15
Wheel Replacement.....	15
Accessories .....	16
<b>SECTION 5: SERVICE</b> .....	<b>17</b>
Troubleshooting.....	17
H7758 Parts Breakdown .....	18
H7758 Parts List.....	19
H7759 Parts Breakdown .....	20
H7759 Parts List.....	21
<b>WARRANTY AND RETURNS</b> .....	<b>22</b>

# INTRODUCTION

---

---

## Foreword

---

---

We are proud to offer the Model H7758/H7759 8" & 10" Bench Grinders. These machines are part of a growing Grizzly family of fine woodworking machinery. When used according to the guidelines set forth in this manual, you can expect years of trouble-free, enjoyable operation and proof of Grizzly's commitment to customer satisfaction.

We are pleased to provide this manual with the Model H7758/H7759. It was written to guide you through assembly, review safety considerations, and cover general operating procedures.

The specifications, drawings, and photographs illustrated in this manual represent the Model H7758/H7759 as supplied when the manual was prepared. For your convenience, we always keep current Grizzly manuals available on our website at **www.grizzly.com**. Any updates to your machine will be reflected in these manuals as soon as they are complete.

## Contact Info

---

---

If you have any comments regarding this manual, please write to us at the address below:

Grizzly Industrial, Inc.  
c/o Technical Documentation Manager  
P.O. Box 2069  
Bellingham, WA 98227-2069  
Email: manuals@grizzly.com

We stand behind our machines. If you have any service questions or parts requests, please call or write us at the location listed below.

Grizzly Industrial, Inc.  
1203 Lycoming Mall Circle  
Muncy, PA 17756  
Phone: (570) 546-9663  
Fax: (800) 438-5901  
E-Mail: techsupport@grizzly.com  
Web Site: <http://www.grizzly.com>





# MACHINE DATA SHEET

Customer Service #: (570) 546-9663 • To Order Call: (800) 523-4777 • Fax #: (800) 438-5901

## MODEL H7758 3/4 HP 8" BENCH GRINDER

Design Type ..... Bench Model

### Overall Dimensions:

Height ..... 12½"  
 Width ..... 15¼"  
 Depth ..... 8⅞"  
 Shipping Weight ..... 37 lbs.  
 Net Weight ..... 34 lbs.  
 Box Size ..... 16⅜" D x 11¼" W x 10⅞" H  
 Footprint ..... 7½" x 5½"  
 Arbor ..... ⅝"  
 Wheel Size ..... 8" x 1"

### Motor:

Type ..... TEFC Capacitor-Start Induction  
 Horsepower ..... ¾ HP  
 Phase / Voltage ..... Single-Phase / 110V  
 Amps (No Load) ..... 5A  
 Cycle / RPM ..... 60 Hertz / 3450 RPM  
 Bearings ..... Shielded & Permanently Lubricated

### Features:

..... Wheel Flanges  
 ..... Standard Tool Rest  
 ..... Tool Rest w/Drill Bit Sharpening Guide  
 ..... Rocker-Type Switch  
 ..... Included 36 Grit Aluminum Oxide Grinding Wheel  
 ..... Included 60 Grit Aluminum Oxide Grinding Wheel

*Specifications, while deemed accurate, are not guaranteed.*





# MACHINE DATA SHEET

Customer Service #: (570) 546-9663 • To Order Call: (800) 523-4777 • Fax #: (800) 438-5901

## MODEL H7759 1 HP 10" BENCH GRINDER

Design Type ..... Bench Model

### Overall Dimensions:

Height ..... 13"  
 Width ..... 18<sup>3</sup>/<sub>4</sub>"  
 Depth ..... 10<sup>5</sup>/<sub>8</sub>"  
 Shipping Weight ..... 70 lbs.  
 Net Weight ..... 67 lbs.  
 Box Size ..... 21" D x 16<sup>1</sup>/<sub>4</sub>" W x 15" H  
 Footprint ..... 9" x 6<sup>1</sup>/<sub>2</sub>"  
 Arbor ..... 1<sup>1</sup>/<sub>4</sub>"  
 Wheel Size ..... 10" x 1"

### Motor:

Type ..... TEFC Capacitor-Start Induction  
 Horsepower ..... 1 HP  
 Phase / Voltage ..... Single-Phase / 110V  
 Amps ..... 10.5  
 Cycle / RPM ..... 60 Hertz / 1725 RPM  
 Bearings ..... Shielded & Permanently Lubricated

### Features:

..... Wheel Flanges  
 ..... Tool Rests  
 ..... Toggle Switch  
 ..... Included 36 Grit Aluminum Oxide Grinding Wheel  
 ..... Included 60 Grit Aluminum Oxide Grinding Wheel

*Specifications, while deemed accurate, are not guaranteed.*



# Identification

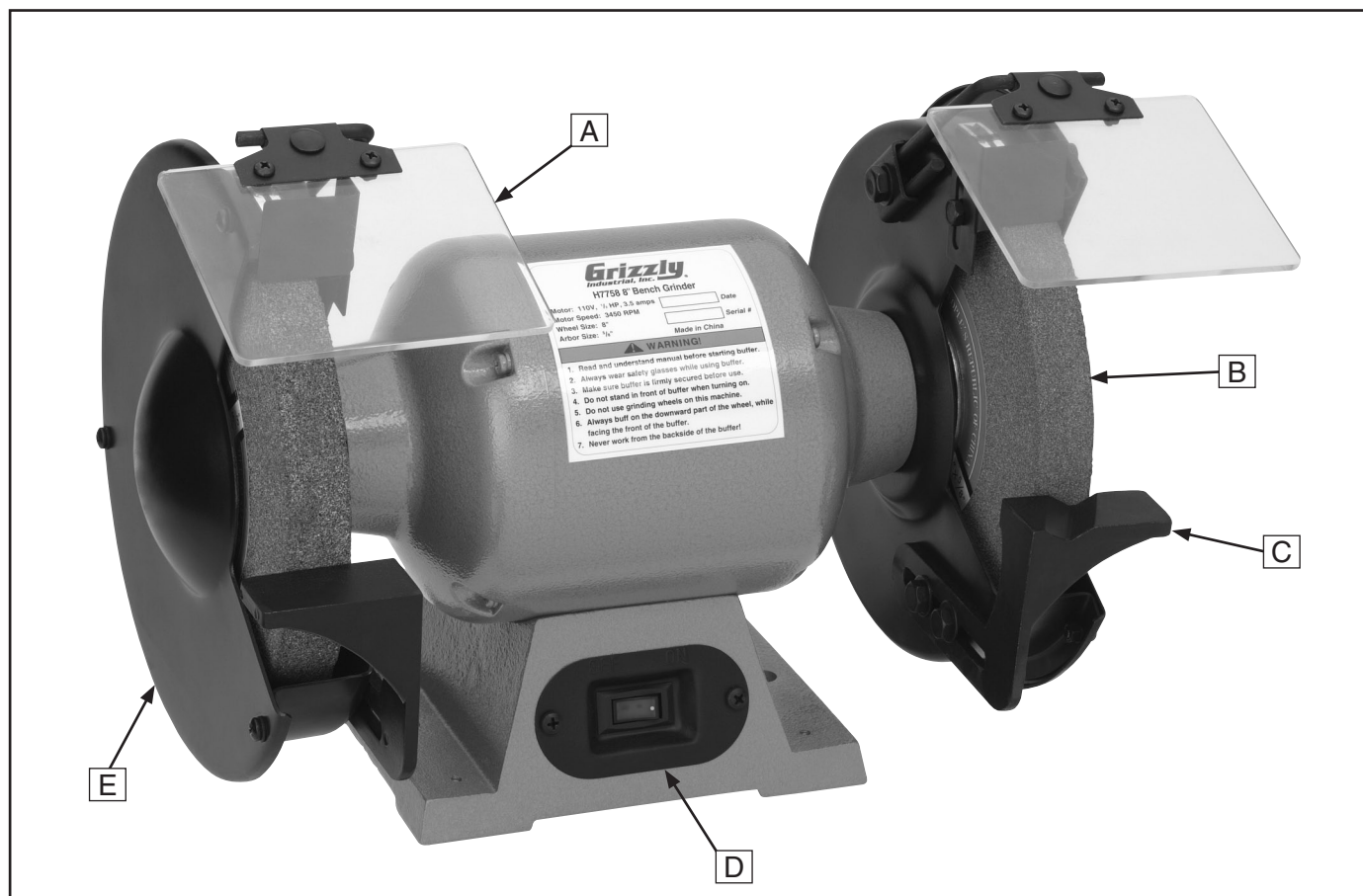

- A. Eye Shield (to be used WITH safety glasses)
- B. Grinding Wheel
- C. Tool Rest
- D. ON/OFF Switch
- E. Wheel Safety Guard



# SECTION 1: SAFETY

## WARNING

### For Your Own Safety, Read Instruction Manual Before Operating this Machine

The purpose of safety symbols is to attract your attention to possible hazardous conditions. This manual uses a series of symbols and signal words which are intended to convey the level of importance of the safety messages. The progression of symbols is described below. Remember that safety messages by themselves do not eliminate danger and are not a substitute for proper accident prevention measures.

 **DANGER** Indicates an imminently hazardous situation which, if not avoided, WILL result in death or serious injury.

 **WARNING** Indicates a potentially hazardous situation which, if not avoided, COULD result in death or serious injury.

 **CAUTION** Indicates a potentially hazardous situation which, if not avoided, MAY result in minor or moderate injury. It may also be used to alert against unsafe practices.

**NOTICE** This symbol is used to alert the user to useful information about proper operation of the machine.

## WARNING

### Safety Instructions for Machinery

- 1. READ THROUGH THE ENTIRE MANUAL BEFORE STARTING MACHINERY.** Machinery presents serious injury hazards to untrained users.
- 2. ALWAYS USE ANSI APPROVED SAFETY GLASSES WHEN OPERATING MACHINERY.** Everyday eyeglasses only have impact resistant lenses, they are NOT safety glasses.
- 3. ALWAYS WEAR AN ANSI APPROVED RESPIRATOR WHEN OPERATING MACHINERY THAT PRODUCES DUST.** Wood dust is a carcinogen and can cause cancer and severe respiratory illnesses.
- 4. ALWAYS USE HEARING PROTECTION WHEN OPERATING MACHINERY.** Machinery noise can cause permanent hearing damage.
- 5. WEAR PROPER APPAREL. DO NOT** wear loose clothing, gloves, neckties, rings, or jewelry which may get caught in moving parts. Wear protective hair covering to contain long hair and wear non-slip footwear.
- 6. NEVER OPERATE MACHINERY WHEN TIRED, OR UNDER THE INFLUENCE OF DRUGS OR ALCOHOL.** Be mentally alert at all times when running machinery.





# WARNING

## Safety Instructions for Machinery

7. **ONLY ALLOW TRAINED AND PROPERLY SUPERVISED PERSONNEL TO OPERATE MACHINERY.** Make sure operation instructions are safe and clearly understood.
8. **KEEP CHILDREN AND VISITORS AWAY.** Keep all children and visitors a safe distance from the work area.
9. **MAKE WORKSHOP CHILD PROOF.** Use padlocks, master switches, and remove start switch keys.
10. **NEVER LEAVE WHEN MACHINE IS RUNNING.** Turn power **OFF** and allow all moving parts to come to a complete stop before leaving machine unattended.
11. **DO NOT USE IN DANGEROUS ENVIRONMENTS.** DO NOT use machinery in damp, wet locations, or where any flammable or noxious fumes may exist.
12. **KEEP WORK AREA CLEAN AND WELL LIT.** Clutter and dark shadows may cause accidents.
13. **USE A GROUNDED EXTENSION CORD RATED FOR THE MACHINE AMPERAGE.** Undersized cords overheat and lose power. Replace extension cords if they become damaged. DO NOT use extension cords for 220V machinery.
14. **ALWAYS DISCONNECT FROM POWER SOURCE BEFORE SERVICING MACHINERY.** Make sure switch is in OFF position before reconnecting.
15. **MAINTAIN MACHINERY WITH CARE.** Keep blades sharp and clean for best and safest performance. Follow instructions for lubricating and changing accessories.
16. **MAKE SURE GUARDS ARE IN PLACE AND WORK CORRECTLY BEFORE USING MACHINERY.**
17. **REMOVE ADJUSTING KEYS AND WRENCHES.** Make a habit of checking for keys and adjusting wrenches before turning machinery **ON**.
18. **CHECK FOR DAMAGED PARTS BEFORE USING MACHINERY.** Check for binding and alignment of parts, broken parts, part mounting, loose bolts, and any other conditions that may affect machine operation. Repair or replace damaged parts.
19. **USE RECOMMENDED ACCESSORIES.** Refer to the instruction manual for recommended accessories. The use of improper accessories may cause risk of injury.
20. **DO NOT FORCE MACHINERY.** Work at the speed for which the machine or accessory was designed.
21. **SECURE WORKPIECE.** Use clamps or a vise to hold the workpiece when practical. A secured workpiece protects your hands and frees both hands to operate the machine.
22. **DO NOT OVERREACH.** Keep proper footing and balance at all times.
23. **MANY MACHINES WILL EJECT THE WORKPIECE TOWARD THE OPERATOR.** Know and avoid conditions that cause the workpiece to "kickback."
24. **ALWAYS LOCK MOBILE BASES (IF USED) BEFORE OPERATING MACHINERY.**
25. **BE AWARE THAT CERTAIN DUST MAY BE HAZARDOUS** to the respiratory systems of people and animals, especially fine dust. Make sure you know the hazards associated with the type of dust you will be exposed to and always wear a respirator approved for that type of dust.



## **WARNING**

# Additional Safety Instructions for Grinders

- 1. EYE PROTECTION.** Grinding ejects small particles at a high rate of speed. **ALWAYS** wear safety glasses when using this machine.
- 2. MOUNTING TO BENCH/STAND.** An unsecured grinder may become dangerously out of control during operation. Make sure grinder is **FIRMLY** secured to a bench/stand before use.
- 3. WHEEL SPEED RATING.** Wheels operated at a faster speed than rated for may break or fly apart. Before mounting a new wheel, be sure the wheel RPM rating is equal or higher than the speed of the grinder.
- 4. WHEEL FLANGES.** Only use the flanges included with the grinder when mounting wheels. Other flanges may not properly secure the wheel and cause an accident.
- 5. RING TEST.** Perform a "ring test" on grinding wheels before installation to ensure that they are safe to use. A wheel that does not pass the ring test may break or fly apart during operation.
- 6. STARTING GRINDER.** If a wheel is damaged, it will usually fly apart shortly after start-up. To protect yourself, always stand to the side of the grinder when turning it **ON** and allow it to gain full speed before standing in front of it.
- 7. LUNG PROTECTION.** Grinding produces hazardous dust, which may cause long-term respiratory problems. Always wear a NIOSH approved dust mask or respirator when grinding.
- 8. SIDE GRINDING.** Grinding on the side of wheels can cause the them to break and fly apart—unless the wheel is rated for side grinding.
- 9. TOP GRINDING.** Grinding on the top of wheels greatly increases the risk of workpiece kickback. Always grind on the downward part of the wheel.
- 10. HAND/WHEEL CONTACT.** Grinding wheels can remove a lot of skin fast. Keep a firm grip on the workpiece and position your hands a safe distance away when grinding. Avoid wearing gloves as they may get caught in the grinding wheel and cause even more serious entanglement injuries.
- 11. TOOL REST POSITION.** If the tool rest is too far away from the wheel, the workpiece may be pulled down, causing loss of control and pulling your hand into the grinding wheel. Keep the tool rest within  $\frac{1}{8}$ " from the wheel when operating.
- 12. CRACKED WHEEL.** Cracked wheels may break and fly apart during operation. Replace cracked wheels immediately!

## **WARNING**

Like all machinery there is potential danger when operating this machine. Accidents are frequently caused by lack of familiarity or failure to pay attention. Use this machine with respect and caution to lessen the possibility of operator injury. If normal safety precautions are overlooked or ignored, serious personal injury may occur.

## **CAUTION**

No list of safety guidelines can be complete. Every shop environment is different. Always consider safety first, as it applies to your individual working conditions. Use this and other machinery with caution and respect. Failure to do so could result in serious personal injury, damage to equipment, or poor work results.



# SECTION 2: CIRCUIT REQUIREMENTS

## 110V Operation

### **!WARNING**

Serious personal injury could occur if you connect the machine to the power source before you have completed the set up process. **DO NOT** connect the machine to the power source until instructed to do so.



### **!WARNING**

Electrocution or fire could result if this machine is not grounded correctly or if your electrical configuration does not comply with local and state codes. Ensure compliance by checking with a qualified electrician!

### Amperage Draw

Model H7758 ..... 5 Amps  
Model H7759 ..... 10.5 Amps

### Circuit Requirements

We recommend connecting this machine to a dedicated circuit with a verified ground, using the circuit breaker size given below. Never replace a circuit breaker with one of higher amperage without consulting a qualified electrician to ensure compliance with wiring codes. **If you are unsure about the wiring codes in your area or you plan to connect your machine to a shared circuit, you may create a fire hazard—consult a qualified electrician to reduce this risk.**

Circuit Breaker..... 15 Amps

### Plug/Receptacle Type

Included Plug Type..... NEMA 5-15

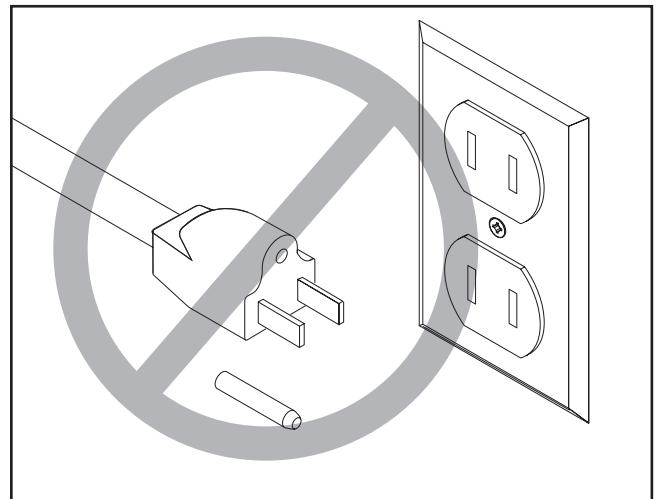

### **!CAUTION**

This machine must have a ground prong in the plug to help ensure that it is grounded. **DO NOT** remove ground prong from plug to fit into a two-pronged outlet! If the plug will not fit the outlet, have the proper outlet installed by a qualified electrician.

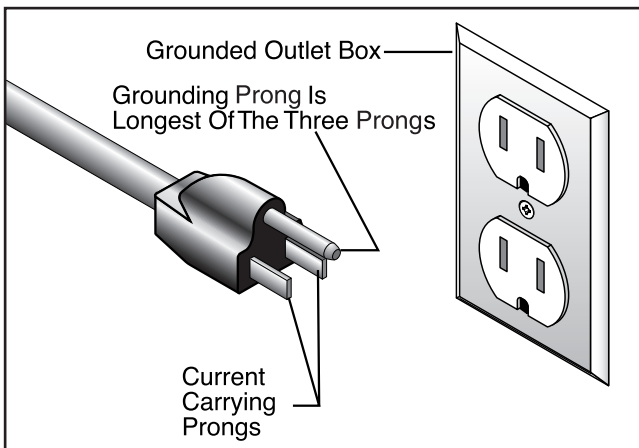

Figure . Typical type 5-15 plug and receptacle.

### Extension Cords

We do not recommend the use of extension cords, if you find it absolutely necessary:

- Use at least a 14 gauge cord that does not exceed 50 feet in length!
- The extension cord must also contain a ground wire and plug pin.
- A qualified electrician **MUST** size cords over 50 feet long to prevent motor damage.



# SECTION 3: SET UP

## Set Up Safety

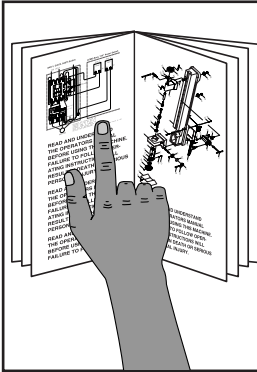

**!WARNING**  
This machine presents serious injury hazards to untrained users. Read through this entire manual to become familiar with the controls and operations before starting the machine!

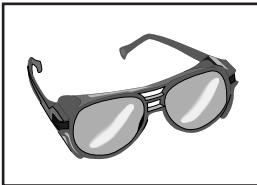

**!WARNING**  
Wear safety glasses during the entire set up process!

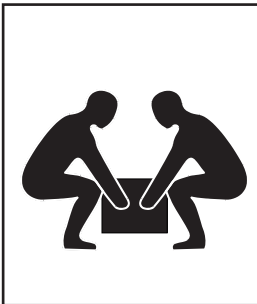

**!WARNING**  
The Model H7758/H7759 is a heavy machine. DO NOT over-exert yourself while unpacking or moving your machine—get assistance.

## Items Needed for Set Up

The following items are needed to complete the set up process, but are not included with your machine:

Description	Qty
• Wrench or Socket 12mm.....	1
• Wrench or Socket 10mm.....	1
• Wrench or Socket 8mm.....	1
• Wrench or Socket 7mm.....	1
• Safety Glasses (for each person) .....	1
• Phillips Screwdriver #2.....	1

## Unpacking

The Model H7758/H7759 was carefully packed when it left our warehouse. If you discover the machine is damaged after you have signed for delivery, *please immediately call Customer Service at (570) 546-9663 for advice.*

Save the containers and all packing materials for possible inspection by the carrier or its agent. *Otherwise, filing a freight claim can be difficult.*

When you are completely satisfied with the condition of your shipment, you should inventory the contents.



# Inventory & Assembly

Use the list below and **Figures 1 & 2** to inventory and assemble your grinder.

H7758 Box Inventory	Qty
A. Grinder .....	1
B. Eye Shields (DO NOT OVERTIGHTEN)....	2
C. Support Arms .....	2
D. Support Retainers .....	2
E. Eyeshield Bracket Assemblies .....	2
F. Tool Rests .....	2
G. Hex Bolts M8-1.25 X 14 .....	2
H. Hex Bolts M8-1.25 X 10 .....	2
I. Hex Bolts M6-1 X 6 .....	2
J. Flat Washers 8mm .....	6
K. Flat Washers 6mm .....	2
L. Spark Deflectors .....	2
M. Phillips Head Screws M4-.7 X 10.....	4
N. Flat Washers 4mm .....	4
O. Lock Washers 4mm .....	4
P. Hex Nuts M4-.7 .....	4

**⚠ WARNING**

**EYE SHIELDS** are the first level of protection from flying debris or sparks and **MUST** be installed before operating the grinder.

H7759 Box Inventory	Qty
A. Grinder .....	1
B. Eye Shields (DO NOT OVERTIGHTEN)....	2
C. Support Arms .....	2
D. Support Retainers .....	2
E. Eyeshield Bracket Assemblies .....	2
F. Tool Rests .....	2
G. Hex Bolts M8-1.25 X 14 .....	2
H. Star Knobs M6-1 x 10 .....	2
I. Flat Washers 8mm .....	2
J. *Spark Deflectors .....	2
K. Phillips Head Screws M4-.7 X 10.....	4
L. Flat Washers 4mm .....	4
M. Lock Washers 4mm .....	4
N. Hex Nuts M4-.7 .....	4

\* The Spark Deflectors (J) attach with the screw, hex nut, and washer that holds the wheel cover in place.

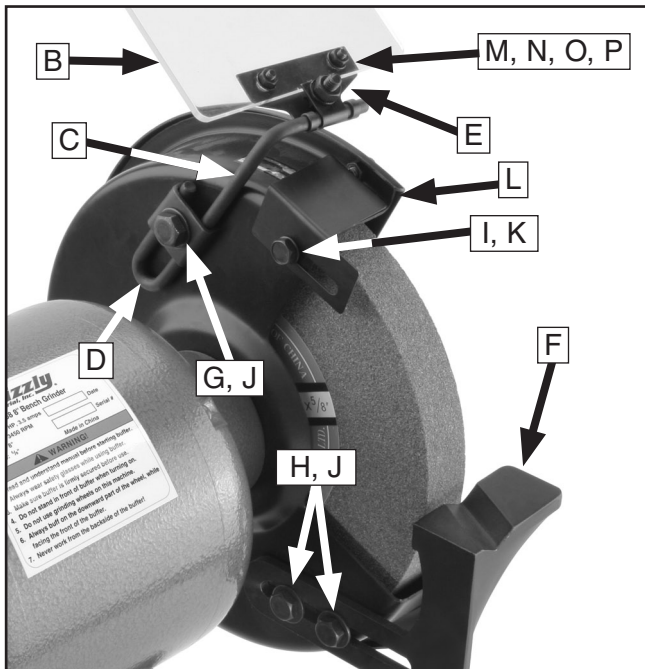

**Figure 1.** H7758 assembly.

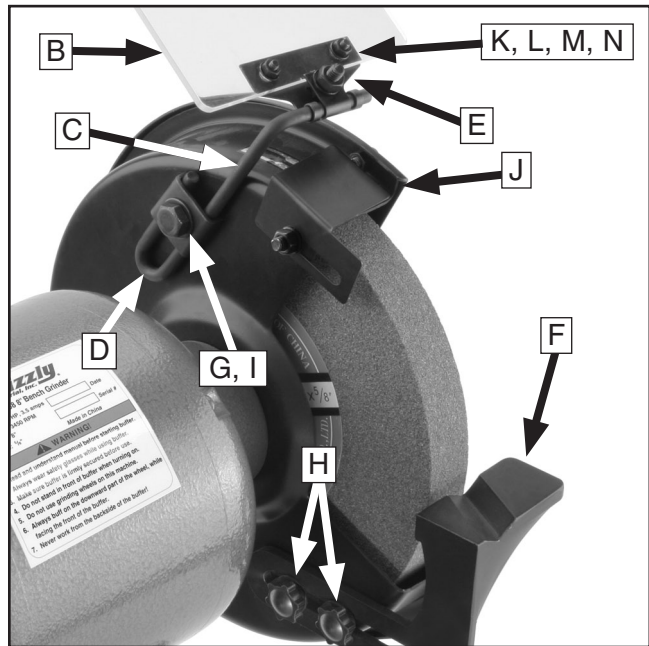

**Figure 2.** H7759 assembly.

In the event that any nonproprietary parts are missing (e.g. a nut or a washer), we would be glad to replace them, or for the sake of expediency, replacements can be obtained at your local hardware store.

**NOTICE**

Some hardware/fasteners in the inventory list may arrive pre-installed on the machine. Check these locations before assuming any items from the inventory list are missing.



# Mounting

---

Mount the grinder on a workbench or stand (see **Page 16**) that is sturdy enough to hold the weight of the machine and any downward pressure that may be applied during operation.

The workbench should have a level surface and be heavy, or attached to the floor, so it will not move during operation.

The grinder can be mounted by drilling a holes in your workbench and securing the grinder with hex bolts, washers, and hex nuts. Or, you can secure it directly into the workbench with lag screws and flat washers. (Mounting hardware is not provided due to the many possible set ups and workbench thicknesses.)

## When locating your grinder, remember:

- You'll need room for potentially large workpieces.
- Grinding spreads dust in the immediate vicinity of the grinder.
- Grinding creates flying sparks that **MUST** be out of reach of any flammables.
- You'll need a lot of light around the grinding wheel.

# Test Run

---

The test run ensures that the grinder and wheels did not get damaged during shipping.

## To test run the grinder:

1. Review and understand the grinder safety information on **Page 6**.
2. Plug the grinder into the power source.
3. Stand away from the line of rotation of the wheel, turn the grinder **ON**, and allow it to run for one minute.

—The grinder should run smoothly.

—If there is an obvious problem with the way the grinder is running, turn it **OFF** immediately and troubleshoot the problem, using the troubleshooting table on **Page 17**. **DO NOT** operate the grinder until it is fixed.



# SECTION 4: OPERATIONS

## Operation Safety

### **!WARNING**

Damage to your eyes, lungs, and ears could result from using this machine without proper protective gear. Always wear safety glasses, a respirator, and hearing protection when operating this machine.

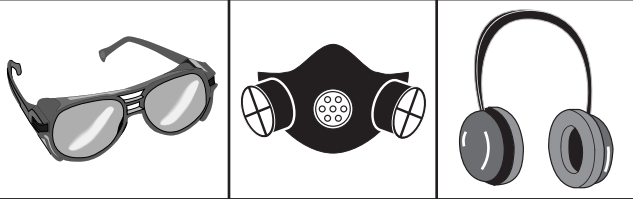

### **!WARNING**

Loose hair and clothing could get caught in machinery and cause serious personal injury. Keep loose clothing and long hair away from moving machinery.

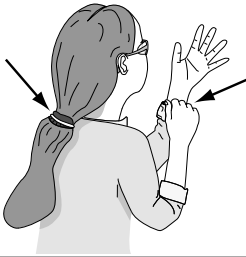

### **NOTICE**

If you have never used this type of machine or equipment before, WE STRONGLY RECOMMEND that you read books, trade magazines, or get formal training before beginning any projects. Regardless of the content in this section, Grizzly Industrial will not be held liable for accidents caused by lack of training.

## Grinding Tips

The grinder is a safe tool when used properly. In addition to the safety instructions in this manual, the most important safety consideration is to use common sense at all times. What may be okay in one situation, may not be safe in another.

Here are some tips to keep in mind while grinding:

- Make sure all guards are in place.
- Remember that grinding often produces sparks. DO NOT allow anyone to stand in the path of the sparks. DO NOT grind near flammable materials.
- Maintain proper care of your wheels. Read the **Wheel Care** instructions for ideas on how to do this.
- Wear the proper protective clothing. Particles flying off of a grinding wheel will be traveling very fast—prepare for this. Wear safety glasses/face shield, a dust mask, earplugs, a leather apron, and heavy leather boots.
- Grasp the workpiece firmly and properly support it on the tool rest during grinding. Maintain even pressure and control of the workpiece when grinding.
- Concentrate on the task at hand. STOP grinding if other people are distracting you or your mind is on something else.
- DO NOT grind on the side of the wheel. The wheels provided with the Model H7758/H7759 are not designed for side grinding.



# Wheel Care

Your safety when grinding depends, on a large part, on the condition of the wheel during grinding. A wheel in poor condition presents the possibility of breaking apart during rotation and injuring the operator and possibly causing property damage.

## Here are some tips to help you avoid breaking the wheel:

- Always transport, store and handle wheels with care. Wheels may be damaged if they are dropped or if heavy objects are stacked on them.
- Select the right grinding wheel for the job. DO NOT grind material inappropriate for the wheel type.
- Select the right wheel for the machine. A machine that rotates at a higher RPM than the wheel is rated for may cause the wheel to fly apart.
- Mount the wheels properly. (See the **Wheel Replacement** instructions on **Page 15** for guidance.) Never use a wheel with the wrong arbor size for the grinder.
- Do not abuse the wheel by jamming the work into the grinding wheel with excessive force.
- Learn how to use the grinder and the grinding wheels properly. Ask a trusted person with experience or consult with your local library to learn more.
- Always spin water/coolant out of the wheel before turning the grinder **OFF**. This may take 5–10 minutes. (If moisture is left on the wheel, the wheel may warp.)
- Do not store wheels in damp or wet locations.
- Grinding on side of the wheel may cause wheel damage.
- Replace wheels when the diameter becomes 2" smaller than its original size.

# Wheel Selection

The Model H7758 only accepts Type 1 wheels with a  $\frac{5}{8}$ " bore. The Model H7759 only accepts Type 1 wheels with a  $1\frac{1}{4}$ " bore.

Aluminum oxide and silicon carbide wheels are marked in a somewhat uniform manner by all the major manufacturers. Understanding these markings will help you understand the capabilities of various wheels. Always refer to the manufacturer's grinding recommendations when selecting a wheel for your project.

## The basic format for wheel numbering is:

Prefix	Abrasive Type	Grit Size	Grade	Bond Type
1	A	60	L	V

The **Prefix** is the manufacturer's designation for a particular wheel type (eg, Type 1 wheels).

The most common **Abrasive Types** used are A for Aluminum Oxide, C for Silicon Carbide, and occasionally SG for Seeded Gel.

The **Grit Size** is a number that refers to the size of the abrasive grain in the wheel. The lower the number, the coarser the wheel. Ten is a very coarse wheel for roughing and 220 is usually the upper range for fine finish work.

**Grade** is an indication of the hardness of the wheel—"A" being the softest and "Z" being the hardest.

**Bond Type** refers to the type of bonding material used to hold the abrasive material. Most general purpose wheels will have a "V" indicating Vitrified Clay is used. Vitrified Clay provides high strength and good porosity. The other common bond type is "B" for resin where synthetic resins are used. These are used to grind cemented carbide and ceramic materials.

**Note:** *There may be other numbers inserted that have meaning for a particular type of wheel. Refer to the manufacturer's technical data for a complete explanation.*





# Wheel Inspection

Before mounting a new grinding wheel, it must be inspected. Do not assume that a wheel is in sound condition just because it is new—often damage can occur in shipping, with age, or with exposure to moisture.

First, do a **Visual Inspection**. Look for any cracks, chips, nicks or dents in the surface of the wheel. If you see any of these, **DO NOT** use the wheel.

Second, do a **Ring Test**. This test will give you an indication of any internal damage that may not be obvious during a visual inspection.

## To perform a Ring Test:

1. Make sure the wheel that you test is clean and dry; otherwise, you may get false results.
2. If size permits, balance the wheel with your finger in the hole. If this is not possible, hang the wheel in the air with a piece of cord or string looped through the hole in the center.
3. At the spots shown in **Figure 3**, gently tap the wheel with a light non-metallic device such as the handle of a screwdriver or a wooden mallet.

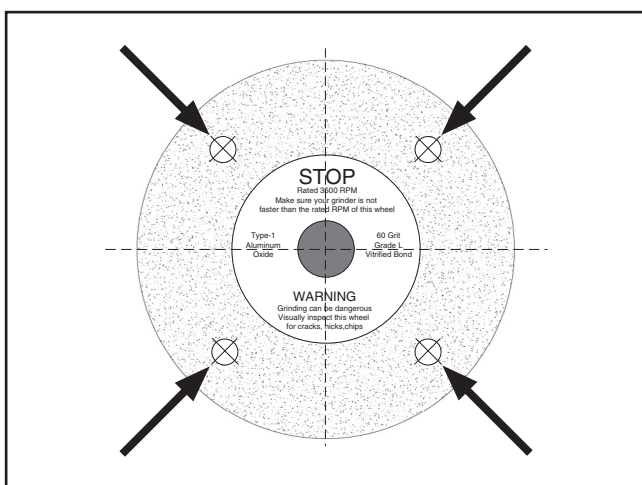

**Figure 3.** Tapping locations when performing a ring test.

4. An undamaged wheel will emit a clear metallic ring or “ping” sound in each of these spots. A damaged wheel will respond with a dull thud that has no clear tone.
5. If you determine from the ring test that the wheel is damaged, **DO NOT** use it!

# Wheel Dressing

Depending on the type of grinding you do, the grinding wheel may require periodic dressing.

There are several different types of wheel dressing devices available on the market (see **Page 16**). Dressing restores the abrasive quality of the wheel surface and brings the wheel edge back to a square form.

Refer to the instructions that accompany your dressing accessory for complete details on how to properly dress a wheel.

# Wheel Replacement

The wheel guard assembly must be removed in order to mount or dismount a grinding wheel.

## To replace a grinding wheel:

1. **UNPLUG THE GRINDER!**
2. Remove the three Phillips head screws and nuts that go through the outer guard. Take off the outer guard and the rim guard.
3. Use a wrench on the nut that holds the wheel on the arbor. Hold the wheel from turning with your other hand. Note that the wheel on the left-hand side of the machine has left-handed threads, so the arbor nut on that side must be turned clockwise to loosen.
4. Remove the outer wheel flange and the paper disc. Pull the wheel free from the arbor. There will also be a paper disc and a wheel flange on the other side of the wheel.

## **CAUTION**

**ALWAYS** visually inspect and perform a "ring test" on a wheel before assembly. **DO NOT** use damaged wheels!

5. Mount the new wheel as shown in **Figure 4**. Always make certain there is a paper or fiber disc between the wheel flanges and the wheel itself. Tighten the nut snugly but **DO NOT** over-tighten. Over-tightening can crack the wheel.

## **CAUTION**

**NEVER** assemble a grinding wheel on the arbor without paper or fiber discs between the wheel and the flange. Not using the discs can put undue stress on the wheel, causing it to crack and possibly fall apart.

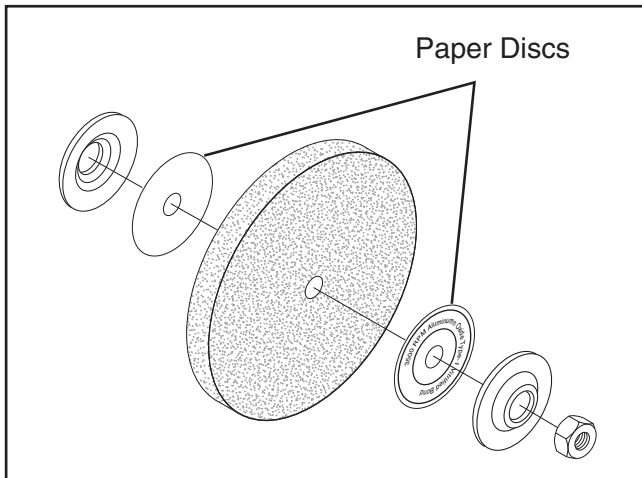

**Figure 4.** Assembly order for wheel installation.

6. Re-install the spark deflectors and eye-shields.
7. Run a new wheel for at least one minute while standing clear of the line of rotation. If a wheel does have defects it will generally fail as soon as it gets up to full speed.

### **H7758 Replacement Wheels**

**Model G1982—8" Aluminum Oxide 36 Grit**  
**Model G1983—8" Aluminum Oxide 60 Grit**  
**Model G1984—8" Silicon Carbide 120 Grit**

## **Accessories**

### **Model H7763—Heavy Duty Grinder Stand**



### **Model H5891—1/2 Carat Diamond Dresser** **Model H5892—3/4 Carat Diamond Dresser**

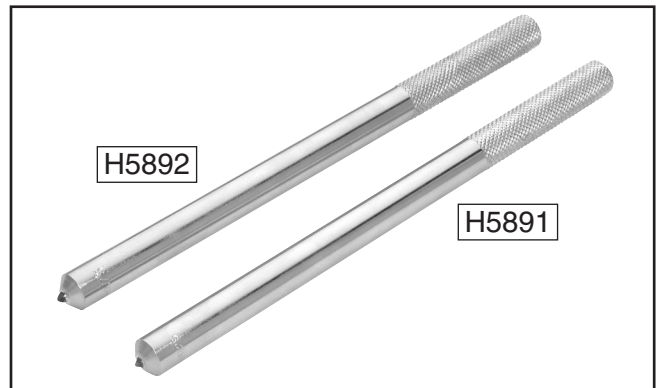

### **H7759 Replacement Wheels**

**Model H8872—10" Aluminum Oxide 36 Grit**  
**Model H8874—10" Aluminum Oxide 60 Grit**

# SECTION 5: SERVICE

Review the troubleshooting and procedures in this section to fix your machine if a problem develops. If you need replacement parts or you are unsure of your repair skills, then feel free to call our Technical Support at (570) 546-9663.

## Troubleshooting

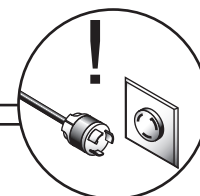

### Motor & Electrical

Symptom	Possible Cause	Possible Solution
Motor will not start.	<ol style="list-style-type: none"> <li>1. Low voltage.</li> <li>2. Open circuit in motor or loose connections.</li> </ol>	<ol style="list-style-type: none"> <li>1. Check power line for proper voltage.</li> <li>2. Inspect all lead connections on motor for loose or open connections.</li> </ol>
Motor will not start; fuses or circuit breakers blow.	<ol style="list-style-type: none"> <li>1. Short circuit in line cord or plug.</li> <li>2. Short circuit in motor or loose connections.</li> <li>3. Incorrect fuses or circuit breakers in power line.</li> </ol>	<ol style="list-style-type: none"> <li>1. Inspect cord or plug for damaged insulation and shorted wires.</li> <li>2. Inspect all connections on motor for loose or shorted terminals or worn insulation.</li> <li>3. Install correct fuses or circuit breakers.</li> </ol>
Motor overheats.	<ol style="list-style-type: none"> <li>1. Motor overloaded.</li> </ol>	<ol style="list-style-type: none"> <li>1. Reduce load on motor.</li> </ol>
Motor stalls (resulting in blown fuses or tripped circuit).	<ol style="list-style-type: none"> <li>1. Short circuit in motor or loose connections.</li> <li>2. Low voltage.</li> <li>3. Incorrect fuses or circuit breakers in power line.</li> <li>4. Motor overloaded.</li> </ol>	<ol style="list-style-type: none"> <li>1. Inspect connections on motor for loose or shorted terminals or worn insulation.</li> <li>2. Correct the low voltage conditions.</li> <li>3. Install correct fuses or circuit breakers.</li> <li>4. Reduce load on motor.</li> </ol>
Machine slows when operating.	<ol style="list-style-type: none"> <li>1. Operator is using too much pressure.</li> </ol>	<ol style="list-style-type: none"> <li>1. Use less pressure when grinding.</li> </ol>
Wavy condition on surface of workpiece.	<ol style="list-style-type: none"> <li>1. Machine vibrating.</li> <li>2. Workpiece not being held firmly.</li> <li>3. Wheel face uneven.</li> <li>4. Wheel is too hard.</li> </ol>	<ol style="list-style-type: none"> <li>1. Make sure machine is securely mounted on a solid surface.</li> <li>2. Use a holding device to firmly retain the workpiece.</li> <li>3. Dress the grinding wheel.</li> <li>4. Use softer wheel, or reduce the feed rate.</li> </ol>
Lines on surface of workpiece.	<ol style="list-style-type: none"> <li>1. Impurity on wheel surface.</li> <li>2. Workpiece not being held tightly.</li> </ol>	<ol style="list-style-type: none"> <li>1. Dress the grinding wheel.</li> <li>2. Use a holding device to firmly retain the workpiece.</li> </ol>
Burning spots or cracks in the workpiece.	<ol style="list-style-type: none"> <li>1. Improper type of grinding wheel.</li> <li>2. Improper feed rate.</li> <li>3. Coolant required.</li> </ol>	<ol style="list-style-type: none"> <li>1. Try a wheel which is softer style or a coarser grit.</li> <li>2. Slow down the rate of movement of the workpiece into wheel.</li> <li>3. Add optional coolant system or introduce coolant by hand.</li> </ol>
Wheel dulls quickly, grit falls off.	<ol style="list-style-type: none"> <li>1. Depth of cut too great.</li> <li>2. Wheel is too soft.</li> <li>3. Wheel diameter too small.</li> <li>4. Bad wheel dress.</li> <li>5. Defective wheel bonding.</li> </ol>	<ol style="list-style-type: none"> <li>1. Slow down the rate of movement of the workpiece into wheel.</li> <li>2. Wheel too soft for the material being ground, select harder bond.</li> <li>3. Replace the wheel.</li> <li>4. Dress the wheel.</li> <li>5. Consult manufacturer of grinding wheel.</li> </ol>
Wheel clogs and workpiece shows burn marks.	<ol style="list-style-type: none"> <li>1. Wheel is too hard.</li> <li>2. Feed rate too slow.</li> <li>3. Bad wheel dress.</li> <li>4. Coolant required.</li> </ol>	<ol style="list-style-type: none"> <li>1. Wheel too hard for the material being ground, select softer bond.</li> <li>2. Increase the rate of movement of the workpiece into wheel.</li> <li>3. Dress the wheel.</li> <li>4. Add optional coolant system or introduce coolant by hand.</li> </ol>



# H7758 Parts Breakdown

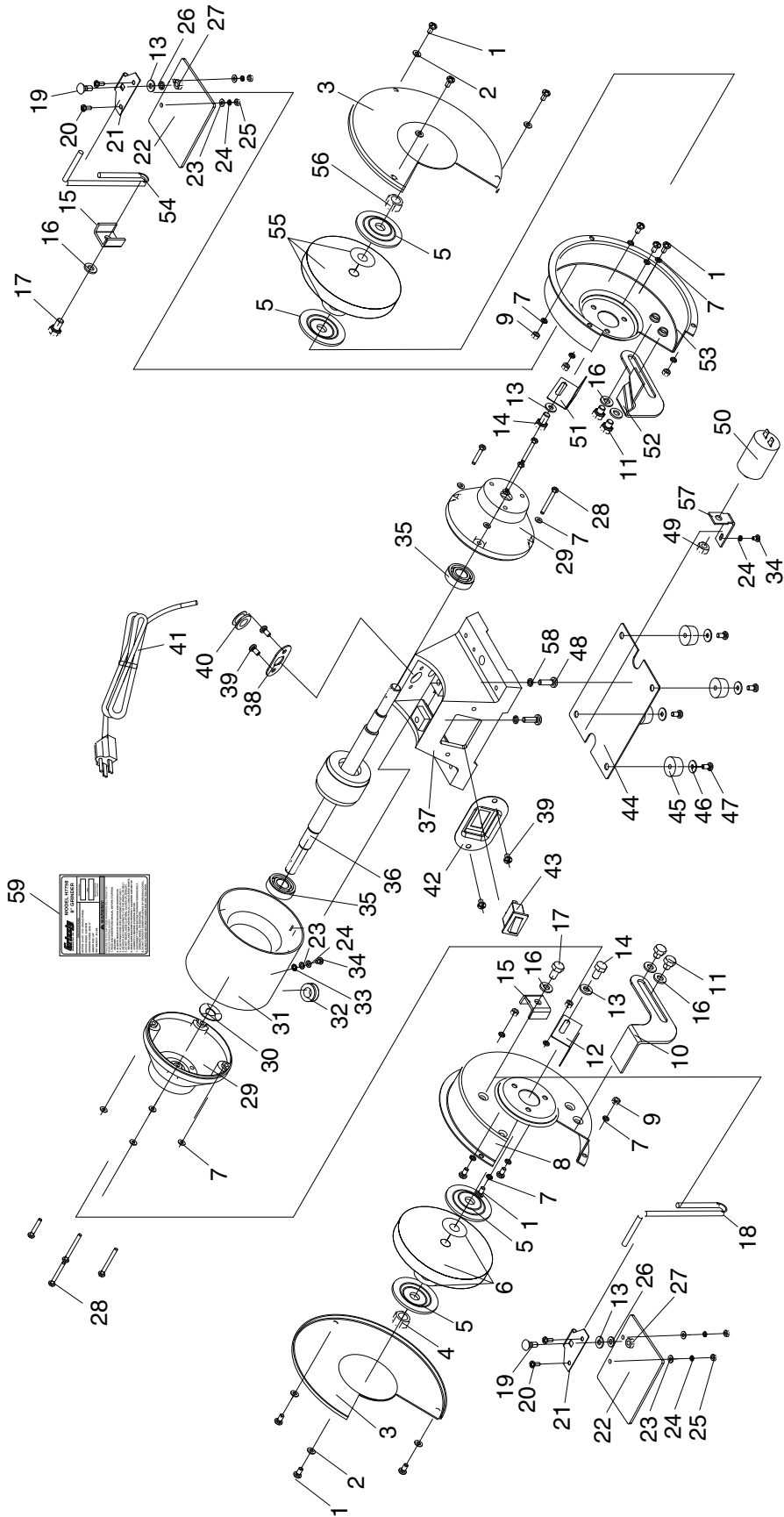

# H7758 Parts List

REF	PART #	DESCRIPTION
1	PS09M	PHLP HD SCR M5-.8 X 10
2	PW02M	FLAT WASHER 5MM
3	PH7758003	WHEEL COVER
4	PN21M	HEX NUT M16-2 (LH)
5	PH7758005	WHEEL FLANGE
6	PH7758006	WHEEL TYPE-1 36-GRIT 8" X 1" X 5/8"
7	PLW01M	LOCK WASHER 5MM
8	PH7758008	LEFT SAFE GUARD
9	PN06M	HEX NUT M5-.8
10	PH7758010	LEFT TOOL REST
11	PB17M	HEX BOLT M8-1.25 X 10
12	PH7758012	LEFT SPARK DEFLECTOR
13	PW03M	FLAT WASHER 6MM
14	PB88M	HEX BOLT M6-1 X 6
15	PH7758015	BRACKET
16	PW01M	FLAT WASHER 8MM
17	PB84M	HEX BOLT M8-1.25 X 14
18	PH7758018	LEFT EYESHIELD MOUNTING ROD
19	PCB22M	CARRIAGE BOLT M6-1 X 16
20	PS38M	PHLP HD SCR M4-.7 X 10
21	PH7758021	EYESHIELD PRESSURE PLATE
22	PH7758022	EYESHIELD
23	PW05M	FLAT WASHER 4MM
24	PLW02M	LOCK WASHER 4MM
25	PN04M	HEX NUT M4-.7
26	PLW03M	LOCK WASHER 6MM
27	PN01M	HEX NUT M6-1
28	PS105M	PHLP HD SCR M5-.8 X 60
29	PH7758029	END BELL
30	PH7758030	WAVE LOCK WASHER 40MM

REF	PART #	DESCRIPTION
31	PH7758031	STATOR
32	PH7758032	CORD CLIP
33	PTLW01M	EXT TOOTH WASHER 4MM
34	PS07M	PHLP HD SCR M4-.7 X 8
35	P6203	BALL BEARING 6203
36	PH7758036	ROTOR
37	PH7758037	BASE
38	PH7758038	CORD BUSHING FIXED PLATE
39	PS05M	PHLP HD SCR M5-.8 X 8
40	PH7758040	CORD CLIP FIXED PLATE
41	PH7758041	CORD AND PLUG
42	PH7758042	SWITCH PLATE
43	PH7758043	SWITCH
44	PH7758044	BASE BOTTOM COVER
45	PH7758045	RUBBER FOOT
46	PH7758046	FENDER WASHER 5MM
47	PS40M	PHLP HD SCR M5-.8 X 16
48	PS04M	PHLP HD SCR M8-1.25 X 20
49	PN03M	HEX NUT M8-1.25
50	PH7758050	CAPACITOR 20M 300VAC 2.5"L X 1.5"D
51	PH7758051	RIGHT SPARK DEFLECTOR
52	PH7758052	RIGHT TOOL REST
53	PH7758053	RIGHT SAFE GUARD
54	PH7758054	RIGHT EYESHIELD MOUNTING ROD
55	PH7758055	WHEEL TYPE-1 60-GRIT 8" X 1" X 5/8"
56	PN13M	HEX NUT M16-2
57	PH7758057	CAPACITOR HOLDER
58	PLW04M	LOCK WASHER 8MM
59	PH7758059	MACHINE ID LABEL

## WARNING

Safety labels warn about machine hazards and ways to prevent injury. The owner of this machine **MUST** maintain the original location and readability of the labels on the machine. If any label is removed or becomes unreadable, **REPLACE** that label before using the machine again. Contact Grizzly at (800) 523-4777 or [www.grizzly.com](http://www.grizzly.com) to order new labels.





# H7759 Parts List

REF	PART #	DESCRIPTION
1	PS06M	PHLP HD SCR M5-.8 X 20
2	PW02M	FLAT WASHER 5MM
3	PH7759003	RUBBER FOOT
4	PH7759004	BASE PLATE
5	PB07M	HEX BOLT M8-1.25 X 25
6	PLW04M	LOCK WASHER 8MM
7	PH7759007	BASE
8	PS05M	PHLP HD SCR M5-.8 X 8
9	PH7759009	SELF-LOCK SWITCH
10	PH7759010	CORD CLIP FIXED PLATE
11	PS05M	PHLP HD SCR M5-.8 X 8
12	PH7759012	WIRE BUSHING
13	PH7759013	POWER CORD
14	PS38M	PHLP HD SCR M4-.7 X 10
15	PW05M	FLAT WASHER 4MM
16	PTLW01M	EXT TOOTH WASHER 4MM
17	PH7759017	CORD CLIP
18	PH7759018	OUTER WHEEL FLANGE
19	PH7759019	WHEEL TYPE-1 60 GRIT 10" X 1" X 1-1/4"
20	PN28M	HEX NUT M20-2.5
21	PH7759021	RIGHT WHEEL GUARD COVER
22	PS105M	PHLP HD SCR M5-.8 X 60
23	PS47M	PHLP HD SCR M6-1 X 25
24	PLW03M	LOCK WASHER 6MM
25	PH7759025	LEFT END CAP
26	PH7759026	WAVE LOCK WASHER 52MM
27	P6205	BEARING 6205
28	PH7759028	LOCK WASHER
29	PH7759029	CENTRIFUGAL SWITCH
30	PH7759030	STATOR
31	PH7759031	ROTOR

REF	PART #	DESCRIPTION
32	PH7759032	RIGHT END CAP
33	PH7759033	STAR KNOB M6-1 X 10
34	PH7759034	RIGHT WORK REST
35	PN06M	HEX NUT M5-.8
36	PH7759036	RIGHT SAFE GUARD
37	PS11M	PHLP HD SCR M6-1 X 16
38	PH7759038	EYESHIELD MOUNTING ROD
39	PH7759039	EYESHIELD
40	PS09M	PHLP HD SCR M5-.8 X 10
41	PH7759041	SWITCH PLATE
42	PH7759042	CAPACITOR HOLDER
43	PH7759043	LEFT SAFE COVER
44	PN36M	HEX NUT M20-2.5 LH
45	PH7759045	WHEEL TYPE-1 36 GRIT 10" X 1" X 1-1/4"
46	PH7759046	LEFT WHEEL GUARD
47	PH7759047	LEFT WORK REST
48	PH7759048	CAPACITOR 150M 125V 1.375"D X 3.125"L
49	PH7759049	RIGHT SPARK DEFECTOR
50	PH7759050	LEFT SPARK DEFECTOR
51	PLW02M	LOCK WASHER 4MM
52	PH7759052	INNER WHEEL FLANGE
53	PH7759053	FENDER WASHER 5MM
54	PS07M	PHLP HD SCR M4-.7 X 8
55	PN04M	HEX NUT M4-.7
56	PH7759056	DOME BOLT
57	PH7759057	PRESSURE PLATE
58	PH7759058	BIG FLAT WASHER 8MM
59	PS106M	PHLP HD SCR M8-1.25 X 14
60	PH7759060	EYESHIELD PRESSURE PLATE
61	PH7759061	MACHINE ID LABEL

## WARNING

Safety labels warn about machine hazards and ways to prevent injury. The owner of this machine **MUST** maintain the original location and readability of the labels on the machine. If any label is removed or becomes unreadable, **REPLACE** that label before using the machine again. Contact Grizzly at (800) 523-4777 or [www.grizzly.com](http://www.grizzly.com) to order new labels.



# WARRANTY AND RETURNS

---

Grizzly Industrial, Inc. warrants every product it sells for a period of **1 year** to the original purchaser from the date of purchase. This warranty does not apply to defects due directly or indirectly to misuse, abuse, negligence, accidents, repairs or alterations or lack of maintenance. This is Grizzly's sole written warranty and any and all warranties that may be implied by law, including any merchantability or fitness, for any particular purpose, are hereby limited to the duration of this written warranty. We do not warrant or represent that the merchandise complies with the provisions of any law or acts unless the manufacturer so warrants. In no event shall Grizzly's liability under this warranty exceed the purchase price paid for the product and any legal actions brought against Grizzly shall be tried in the State of Washington, County of Whatcom.

We shall in no event be liable for death, injuries to persons or property or for incidental, contingent, special, or consequential damages arising from the use of our products.

To take advantage of this warranty, contact us by mail or phone and give us all the details. We will then issue you a "Return Number," which must be clearly posted on the outside as well as the inside of the carton. We will not accept any item back without this number. Proof of purchase must accompany the merchandise.

The manufacturers reserve the right to change specifications at any time because they constantly strive to achieve better quality equipment. We make every effort to ensure that our products meet high quality and durability standards and we hope you never need to use this warranty.

Please feel free to write or call us if you have any questions about the machine or the manual.

Thank you again for your business and continued support. We hope to serve you again soon.







# WARRANTY CARD

Name \_\_\_\_\_  
 Street \_\_\_\_\_  
 City \_\_\_\_\_ State \_\_\_\_\_ Zip \_\_\_\_\_  
 Phone # \_\_\_\_\_ Email \_\_\_\_\_ Invoice # \_\_\_\_\_  
 Model # \_\_\_\_\_ Order # \_\_\_\_\_ Serial # \_\_\_\_\_

The following information is given on a voluntary basis. It will be used for marketing purposes to help us develop better products and services. **Of course, all information is strictly confidential.**

1. How did you learn about us?

Advertisement                       Friend                       Catalog  
 Card Deck                               Website                       Other:

2. Which of the following magazines do you subscribe to?

<input type="checkbox"/> Cabinet Maker	<input type="checkbox"/> Popular Mechanics	<input type="checkbox"/> Today's Homeowner
<input type="checkbox"/> Family Handyman	<input type="checkbox"/> Popular Science	<input type="checkbox"/> Wood
<input type="checkbox"/> Hand Loader	<input type="checkbox"/> Popular Woodworking	<input type="checkbox"/> Wooden Boat
<input type="checkbox"/> Handy	<input type="checkbox"/> Practical Homeowner	<input type="checkbox"/> Woodshop News
<input type="checkbox"/> Home Shop Machinist	<input type="checkbox"/> Precision Shooter	<input type="checkbox"/> Woodsmith
<input type="checkbox"/> Journal of Light Cont.	<input type="checkbox"/> Projects in Metal	<input type="checkbox"/> Woodwork
<input type="checkbox"/> Live Steam	<input type="checkbox"/> RC Modeler	<input type="checkbox"/> Woodworker West
<input type="checkbox"/> Model Airplane News	<input type="checkbox"/> Rifle	<input type="checkbox"/> Woodworker's Journal
<input type="checkbox"/> Modeltec	<input type="checkbox"/> Shop Notes	<input type="checkbox"/> Other:
<input type="checkbox"/> Old House Journal	<input type="checkbox"/> Shotgun News	

3. What is your annual household income?

\$20,000-\$29,000                       \$30,000-\$39,000                       \$40,000-\$49,000  
 \$50,000-\$59,000                       \$60,000-\$69,000                       \$70,000+

4. What is your age group?

20-29                                       30-39                                       40-49  
 50-59                                       60-69                                       70+

5. How long have you been a woodworker/metalworker?

0-2 Years                       2-8 Years                       8-20 Years                       20+ Years

6. How many of your machines or tools are Grizzly?

0-2                       3-5                       6-9                       10+

7. Do you think your machine represents a good value?

Yes                       No

8. Would you recommend Grizzly Industrial to a friend?

Yes                       No

9. Would you allow us to use your name as a reference for Grizzly customers in your area?

**Note: We never use names more than 3 times.**                       Yes                       No

10. Comments: \_\_\_\_\_  
 \_\_\_\_\_  
 \_\_\_\_\_

CUT ALONG DOTTED LINE

FOLD ALONG DOTTED LINE

\_\_\_\_\_

\_\_\_\_\_

\_\_\_\_\_



Place  
Stamp  
Here



**GRIZZLY INDUSTRIAL, INC.**  
**P.O. BOX 2069**  
**BELLINGHAM, WA 98227-2069**



FOLD ALONG DOTTED LINE

Send a Grizzly Catalog to a friend:

Name _____
Street _____
City _____ State _____ Zip _____

TAPE ALONG EDGES--PLEASE DO NOT STAPLE



# *grizzly.com*

**TOOL WEBSITE**

Buy Direct and Save with Grizzly® – Trusted, Proven and a Great Value!

*Visit Our Website Today And Discover  
Why Grizzly® Is The Industry Leader!*

- SECURE ORDERING
- ORDERS SHIPPED WITHIN 24 HOURS
- E-MAIL RESPONSE WITHIN ONE HOUR

-OR-

Call Today For A **FREE**  
Full Color Catalog

**1-800-523-4777**



## Free Manuals Download Website

<http://myh66.com>

<http://usermanuals.us>

<http://www.somanuals.com>

<http://www.4manuals.cc>

<http://www.manual-lib.com>

<http://www.404manual.com>

<http://www.luxmanual.com>

<http://aubethermostatmanual.com>

Golf course search by state

<http://golfingnear.com>

Email search by domain

<http://emailbydomain.com>

Auto manuals search

<http://auto.somanuals.com>

TV manuals search

<http://tv.somanuals.com>