

G4787 Breakdown

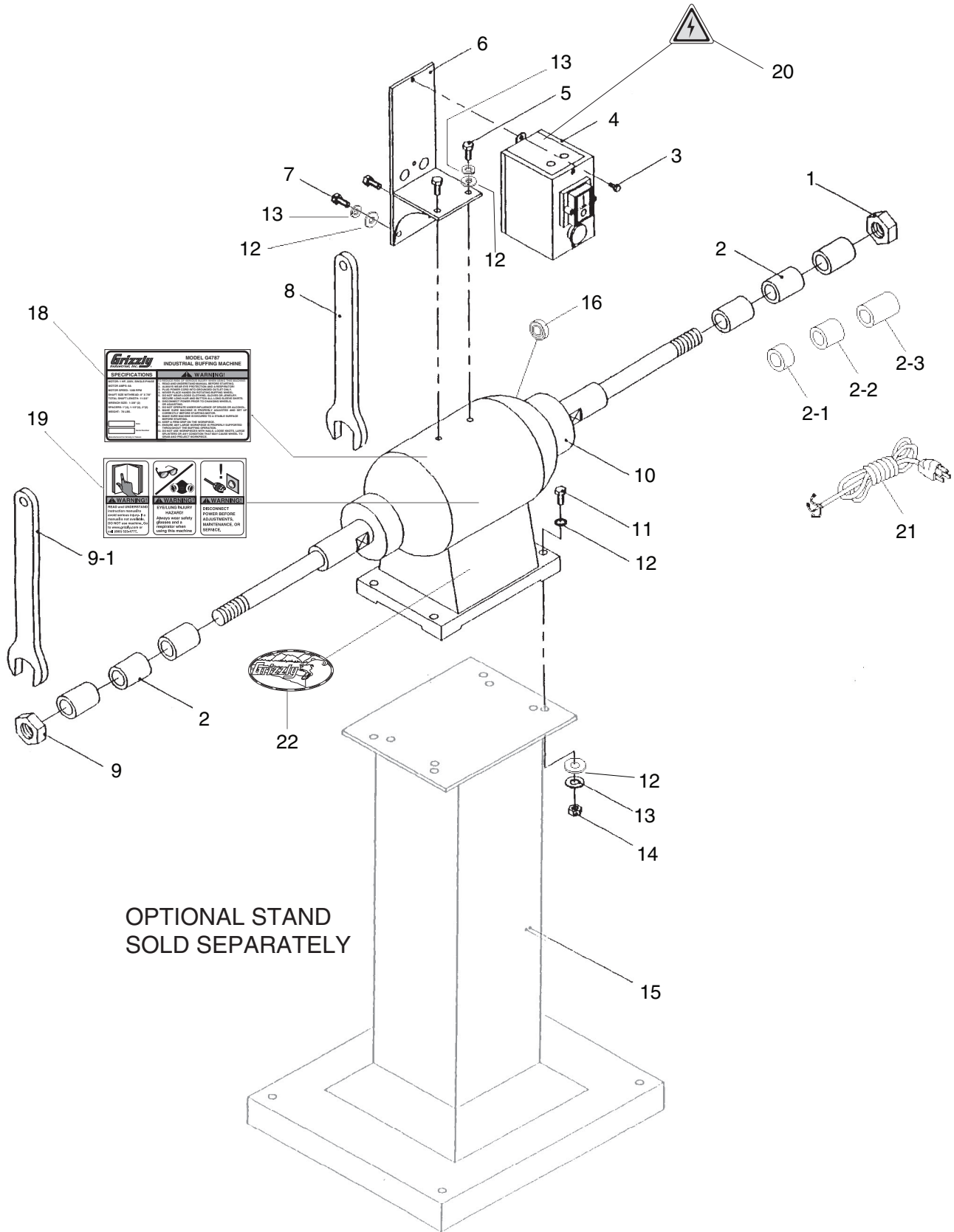

G4787 Parts List

REF	PART #	DESCRIPTION
1	PN36	HEX NUT 1-1/4"-7
2	P4787002	COMPLETE SPACER SET
2-1	P3623002-1	SPACER 1-1/4" X 1"
2-2	P3623002-2	SPACER 1-1/4" X 1-1/2"
2-3	P3623002-3	SPACER 1-1/4" X 2"
3	PS06	PHLP HD SCR 10-24 X 3/8
4	P4787004	SWITCH MS-11-3PV (3HP-3PH)
5	PB07	HEX BOLT 5/16-18 X 3/4
6	P4787006	SWITCH SUPPORT
7	PB07	HEX BOLT 5/16-18 X 3/4
8	P3623008	WRENCH 1-1/2"
9	PN37	HEX NUT 1-1/4"-7 LH
9-1	PWR2	WRENCH 2"

REF	PART #	DESCRIPTION
10	P4787010	MOTOR 3HP, 220V, 3-PH
11	PB06	HEX BOLT 5/16-18 X 2
12	PW07	FLAT WASHER 5/16
13	PLW01	LOCK WASHER 5/16
14	PN02	HEX NUT 5/16"-18
15	G4789	STAND (OPTIONAL)
16	P6209	BALL BEARING 6209ZZ
18	P4787018	MACHINE ID LABEL
19	P3622019	SAFETY WARNING LABELS
20	P3622020	ELECTRICITY LABEL 0.7W X 0.6H
21	P3708021	POWER CORD 12AWG x 4C
22	G9987	SMALL GRIZZLY NAMEPLATE

WARNING

Safety labels warn about machine hazards and ways to prevent injury. The owner of this machine **MUST** maintain the original location and readability of the labels on the machine. If any label is removed or becomes unreadable, **REPLACE** that label before using the machine again. Contact Grizzly at (800) 523-4777 or www.grizzly.com to order new labels.



Free Manuals Download Website

<http://myh66.com>

<http://usermanuals.us>

<http://www.somanuals.com>

<http://www.4manuals.cc>

<http://www.manual-lib.com>

<http://www.404manual.com>

<http://www.luxmanual.com>

<http://aubethermostatmanual.com>

Golf course search by state

<http://golfingnear.com>

Email search by domain

<http://emailbydomain.com>

Auto manuals search

<http://auto.somanuals.com>

TV manuals search

<http://tv.somanuals.com>