

# *Grizzly* *Industrial, Inc.*®

## MODEL G0596/G0597/G0598/G0599 INDUSTRIAL BENCH GRINDER OWNER'S MANUAL



COPYRIGHT © JANUARY, 2006 BY GRIZZLY INDUSTRIAL, INC.  
**WARNING: NO PORTION OF THIS MANUAL MAY BE REPRODUCED IN ANY SHAPE  
OR FORM WITHOUT THE WRITTEN APPROVAL OF GRIZZLY INDUSTRIAL, INC.**  
#PC7907 PRINTED IN TAIWAN

# **WARNING!**

**This manual provides critical safety instructions on the proper setup, operation, maintenance and service of this machine/equipment.**

**Failure to read, understand and follow the instructions given in this manual may result in serious personal injury, including amputation, electrocution or death.**

**The owner of this machine/equipment is solely responsible for its safe use. This responsibility includes but is not limited to proper installation in a safe environment, personnel training and usage authorization, proper inspection and maintenance, manual availability and comprehension, application of safety devices, blade/cutter integrity, and the usage of personal protective equipment.**

**The manufacturer will not be held liable for injury or property damage from negligence, improper training, machine modifications or misuse.**

# **WARNING!**

**Some dust created by power sanding, sawing, grinding, drilling, and other construction activities contains chemicals known to the State of California to cause cancer, birth defects or other reproductive harm. Some examples of these chemicals are:**

- **Lead from lead-based paints.**
- **Crystalline silica from bricks, cement and other masonry products.**
- **Arsenic and chromium from chemically-treated lumber.**

**Your risk from these exposures varies, depending on how often you do this type of work. To reduce your exposure to these chemicals: Work in a well ventilated area, and work with approved safety equipment, such as those dust masks that are specially designed to filter out microscopic particles.**

# Table of Contents

<b>INTRODUCTION</b> .....	<b>2</b>
Foreword .....	2
Contact Info.....	2
Machine Data Sheet.....	3
Identification .....	3
<b>SECTION 1: SAFETY</b> .....	<b>4</b>
Safety Instructions for Machinery.....	4
<b>SECTION 2: CIRCUIT REQUIREMENTS</b> .....	<b>7</b>
Operation.....	7
Grounding.....	8
Extension Cords.....	8
Phase Converter .....	8
<b>SECTION 3: SET UP</b> .....	<b>9</b>
Set Up Safety .....	9
Items Needed for Set Up .....	9
Unpacking .....	9
Inventory.....	10
Eye Shields .....	10
Hardware Recognition Chart.....	12
<b>SECTION 4: OPERATIONS</b> .....	<b>13</b>
Operation Safety .....	13
Wheel Care .....	14
Wheel Selection .....	14
Wheel Inspection.....	15
Wheel Replacement.....	16
<b>SECTION 5: ACCESSORIES</b> .....	<b>17</b>
<b>SECTION 6: SERVICE</b> .....	<b>18</b>
Troubleshooting.....	18
110V Wiring Diagram G0596 .....	19
Single Phase .....	19
220V Wiring Diagram G0597/G0598 .....	20
Single Phase .....	20
220V Wiring Diagram G0599 .....	21
3-Phase .....	21
Parts Breakdown Main .....	22
Parts Breakdown Shield.....	23
Parts List G0596-G0597 .....	24
Parts List G0598-G0599 .....	25
<b>WARRANTY AND RETURNS</b> .....	<b>26</b>

# INTRODUCTION

---

---

## Foreword

---

---

We are proud to offer the Model G0596/G0597/G0598/G0599 Industrial Bench Grinder. This machine is part of a growing Grizzly family of fine metalworking machinery. When used according to the guidelines set forth in this manual, you can expect years of trouble-free, enjoyable operation and proof of Grizzly's commitment to customer satisfaction.

We are pleased to provide this manual with the Model G0596/G0597/G0598/G0599. It was written to guide you through assembly, review safety considerations, and cover general operating procedures. It represents our effort to produce the best documentation possible.

The specifications, drawings, and photographs illustrated in this manual represent the Model G0596/G0597/G0598/G0599 as supplied when the manual was prepared. However, owing to Grizzly's policy of continuous improvement, changes may be made at any time with no obligation on the part of Grizzly. For your convenience, we always keep current Grizzly manuals available on our website at **www.grizzly.com**. Any updates to your machine will be reflected in these manuals as soon as they are complete. Visit our site often to check for the latest updates to this manual!

## Contact Info

---

---

If you have any comments regarding this manual, please write to us at the address below:

Grizzly Industrial, Inc.  
c/o Technical Documentation Manager  
P.O. Box 2069  
Bellingham, WA 98227-2069

We stand behind our machines. If you have any service questions or parts requests, please call or write us at the location listed below.

Grizzly Industrial, Inc.  
1203 Lycoming Mall Circle  
Muncy, PA 17756  
Phone: (570) 546-9663  
Fax: (800) 438-5901  
E-Mail: [techsupport@grizzly.com](mailto:techsupport@grizzly.com)  
Web Site: <http://www.grizzly.com>



## MODEL G0596/G0597/G0598/G0599

	G0596	G0597	G0598	G0599
Motor HP	1	1½	2	3
Voltage/Phase	110, 1-PH	220V, 1-PH	220V, 1-PH	220V, 3-PH
Amps	14A	8.5A	12A	10A
RPM	1800	1800	1200	1200
Wheel Size	8 x 1 x 1"	10 x 1 x 1"	12 x 1½ x 1¼"	12 x 2 x 1¼"
Wheel Type	Type 1	Type 1	Type 1	Type 1
Arbor Size	1"	1"	1¼"	1¼"
Height	18½"	18½"	22"	22"
Width	24"	24"	30"	30"
Depth	16"	17½"	19"	19"
Dust Port Diameter	2½"	2½"	3"	3"
Net Weight	118 Lbs.	132 Lbs.	220 Lbs.	226 Lbs.
Shipping Weight	140 Lbs.	155 Lbs.	264 Lbs.	270 Lbs.
Shipping Dimensions	28 x 20 x 16"	28 x 22 x 18"	34 x 24 x 20"	34 x 24 x 20"

## Identification

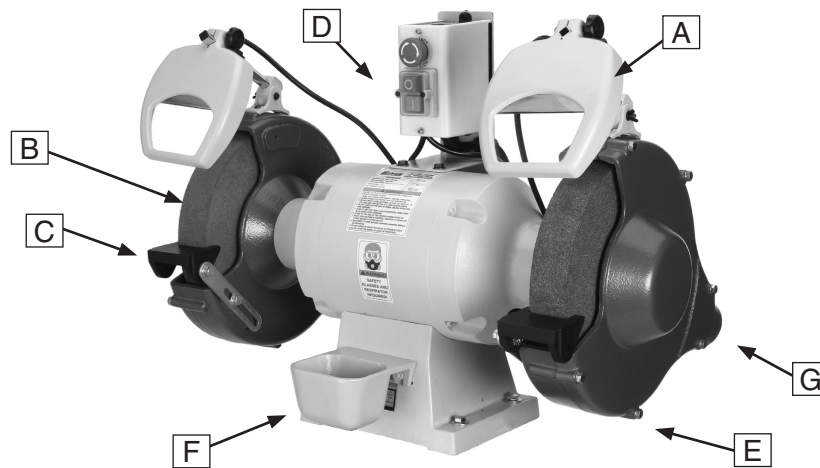

- A. Lighted Eye Shield (to be used WITH safety glasses and face shield)
- B. Grinding Wheel
- C. Tool Rest

- D. ON/OFF Switch
- E. Wheel Safety Guard
- F. Coolant Cup
- G. Dust Port

# SECTION 1: SAFETY

## WARNING

### For Your Own Safety, Read Instruction Manual Before Operating this Machine

The purpose of safety symbols is to attract your attention to possible hazardous conditions. This manual uses a series of symbols and signal words which are intended to convey the level of importance of the safety messages. The progression of symbols is described below. Remember that safety messages by themselves do not eliminate danger and are not a substitute for proper accident prevention measures.

 **DANGER** Indicates an imminently hazardous situation which, if not avoided, **WILL** result in death or serious injury.

 **WARNING** Indicates a potentially hazardous situation which, if not avoided, **COULD** result in death or serious injury.

 **CAUTION** Indicates a potentially hazardous situation which, if not avoided, **MAY** result in minor or moderate injury. It may also be used to alert against unsafe practices.

**NOTICE** This symbol is used to alert the user to useful information about proper operation of the machine.

## WARNING

### Safety Instructions for Machinery

- 1. READ THROUGH THE ENTIRE MANUAL BEFORE STARTING MACHINERY.** Machinery presents serious injury hazards to untrained users.
- 2. ALWAYS USE ANSI APPROVED SAFETY GLASSES WHEN OPERATING MACHINERY.** Everyday eyeglasses only have impact resistant lenses—they are NOT safety glasses.
- 3. ALWAYS WEAR AN ANSI APPROVED RESPIRATOR WHEN OPERATING MACHINERY THAT PRODUCES DUST.** Wood dust is a carcinogen and can cause cancer and severe respiratory illnesses.
- 4. ALWAYS USE HEARING PROTECTION WHEN OPERATING MACHINERY.** Machinery noise can cause permanent hearing damage.
- 5. WEAR PROPER APPAREL. DO NOT** wear loose clothing, gloves, neckties, rings, or jewelry which may get caught in moving parts. Wear protective hair covering to contain long hair and wear non-slip footwear.
- 6. NEVER OPERATE MACHINERY WHEN TIRED, OR UNDER THE INFLUENCE OF DRUGS OR ALCOHOL.** Be mentally alert at all times when running machinery.



# WARNING

## Safety Instructions for Machinery

7. **ONLY ALLOW TRAINED AND PROPERLY SUPERVISED PERSONNEL TO OPERATE MACHINERY.** Make sure operation instructions are safe and clearly understood.
8. **KEEP CHILDREN AND VISITORS AWAY.** Keep all children and visitors a safe distance from the work area.
9. **MAKE WORKSHOP CHILD PROOF.** Use padlocks, master switches, and remove start switch keys.
10. **NEVER LEAVE WHEN MACHINE IS RUNNING.** Turn power **OFF** and allow all moving parts to come to a complete stop before leaving machine unattended.
11. **DO NOT USE IN DANGEROUS ENVIRONMENTS.** DO NOT use machinery in damp, wet locations, or where any flammable or noxious fumes may exist.
12. **KEEP WORK AREA CLEAN AND WELL LIT.** Clutter and dark shadows may cause accidents.
13. **USE A GROUNDED EXTENSION CORD RATED FOR THE MACHINE AMPERAGE.** Undersized cords overheat and lose power. Replace extension cords if they become damaged. DO NOT use extension cords for 220V machinery.
14. **ALWAYS DISCONNECT FROM POWER SOURCE BEFORE SERVICING MACHINERY.** Make sure switch is in OFF position before reconnecting.
15. **MAINTAIN MACHINERY WITH CARE.** Keep blades sharp and clean for best and safest performance. Follow instructions for lubricating and changing accessories.
16. **MAKE SURE GUARDS ARE IN PLACE AND WORK CORRECTLY BEFORE USING MACHINERY.**
17. **REMOVE ADJUSTING KEYS AND WRENCHES.** Make a habit of checking for keys and adjusting wrenches before turning machinery **ON**.
18. **CHECK FOR DAMAGED PARTS BEFORE USING MACHINERY.** Check for binding and alignment of parts, broken parts, part mounting, loose bolts, and any other conditions that may affect machine operation. Repair or replace damaged parts.
19. **USE RECOMMENDED ACCESSORIES.** Refer to the instruction manual for recommended accessories. The use of improper accessories may cause risk of injury.
20. **DO NOT FORCE MACHINERY.** Work at the speed for which the machine or accessory was designed.
21. **SECURE WORKPIECE.** Use clamps or a vise to hold the workpiece when practical. A secured workpiece protects your hands and frees both hands to operate the machine.
22. **DO NOT OVERREACH.** Keep proper footing and balance at all times.
23. **MANY MACHINES WILL EJECT THE WORKPIECE TOWARD THE OPERATOR.** Know and avoid conditions that cause the workpiece to "kickback."
24. **ALWAYS LOCK MOBILE BASES (IF USED) BEFORE OPERATING MACHINERY.**
25. **BE AWARE THAT CERTAIN DUST MAY BE HAZARDOUS** to the respiratory systems of people and animals, especially fine dust. Make sure you know the hazards associated with the type of dust you will be exposed to and always wear a respirator approved for that type of dust.





## **WARNING**

# Additional Safety Instructions for Grinders

- 1. EYE PROTECTION.** Grinding ejects small particles at a high rate of speed. ALWAYS wear safety glasses when using this machine.
- 2. MOUNTING TO BENCH/STAND.** An unsecured grinder may become dangerously out of control during operation. Make sure grinder is FIRMLY secured to a bench/stand before use.
- 3. WHEEL SPEED RATING.** Wheels operated at a faster speed than rated for may break or fly apart. Before mounting a new wheel, be sure the wheel RPM rating is equal or higher than the speed of the grinder.
- 4. WHEEL FLANGES.** Only use the flanges included with the grinder when mounting wheels. Other flanges may not properly secure the wheel and cause an accident.
- 5. RING TEST.** Perform a "ring test" on grinding wheels before installation to ensure that they are safe to use. A wheel that does not pass the ring test may break or fly apart during operation.
- 6. STARTING GRINDER.** If a wheel is damaged, it will usually fly apart shortly after start-up. To protect yourself, always stand to the side of the grinder when turning it **ON** and allow it to run a full minute before standing in front of it.
- 7. LUNG PROTECTION.** Grinding produces hazardous dust, which may cause long-term respiratory problems. Always wear a NIOSH-approved dust mask or respirator when grinding.
- 8. SIDE GRINDING.** Grinding on the side of wheels can cause the them to break and fly apart—unless the wheel is rated for side grinding.
- 9. TOP GRINDING.** Grinding on the top of wheels greatly increases the risk of workpiece kickback. Always grind on the downward part of the wheel.
- 10. HAND/WHEEL CONTACT.** Grinding wheels can remove a lot of skin fast. Keep a firm grip on the workpiece and position your hands a safe distance away when grinding. DO NOT wear gloves as they may get caught in the grinding wheel and cause even more serious injuries.
- 11. TOOL REST POSITION.** If the tool rest is too far away from the wheel, the workpiece may be pulled down, causing loss of control and pulling your hand into the grinding wheel. Keep the tool rest within  $\frac{1}{8}$ " from the wheel when operating.
- 12. CRACKED WHEEL.** Cracked wheels may break and fly apart during operation. Replace cracked wheels immediately!

## **WARNING**

Like all machinery there is potential danger when operating this machine. Accidents are frequently caused by lack of familiarity or failure to pay attention. Use this machine with respect and caution to lessen the possibility of operator injury. If normal safety precautions are overlooked or ignored, serious personal injury may occur.

## **CAUTION**

No list of safety guidelines can be complete. Every shop environment is different. Always consider safety first, as it applies to your individual working conditions. Use this and other machinery with caution and respect. Failure to do so could result in serious personal injury, damage to equipment, or poor work results.





# SECTION 2: CIRCUIT REQUIREMENTS

## Operation

### **!WARNING**

Serious personal injury could occur if you connect the machine to the power source before you have completed the set up process. **DO NOT** connect the machine to the power source until instructed to do so.

### Amperage Draw

The motor for your machine may draw the following amps at maximum load.

G0596 at 110V Single-Phase .....	14 Amps
G0597 at 220V Single-Phase.....	8.5 Amps
G0598 at 220V Single-Phase.....	12 Amps
G0599 at 220V 3-Phase.....	10 Amps

### Circuit Requirements

We recommend connecting this machine to a dedicated circuit with a verified ground, using the circuit breaker size given below. Never replace a circuit breaker with one of higher amperage without consulting a qualified electrician to ensure compliance with wiring codes. **If you are unsure about the wiring codes in your area or you plan to connect your machine to a shared circuit, you may create a fire hazard—consult a qualified electrician to reduce this risk.**

G0596 at 110V.....	15 Amp Circuit Breaker
G0597 at 220V .....	15 Amp Circuit Breaker
G0598 at 220V .....	15 Amp Circuit Breaker
G0599 at 220V 3-Phase.	15 Amp Circuit Breaker

### Plug Type

With the exception of the G0596, the cord set enclosed does not have a plug as the style of plug you require will depend upon the type of service you currently have or plan to install. We recommend using the following plugs for your machine on a dedicated circuit only (see **Figures 1–3** for examples):

G0597 at 220V .....	NEMA 6-15 Plug
G0598 at 220V .....	NEMA 6-15 Plug
G0599 at 220V 3-Phase..	NEMA 15-15R Plug or ..220V Locking Shut-Off Switch (recommended)

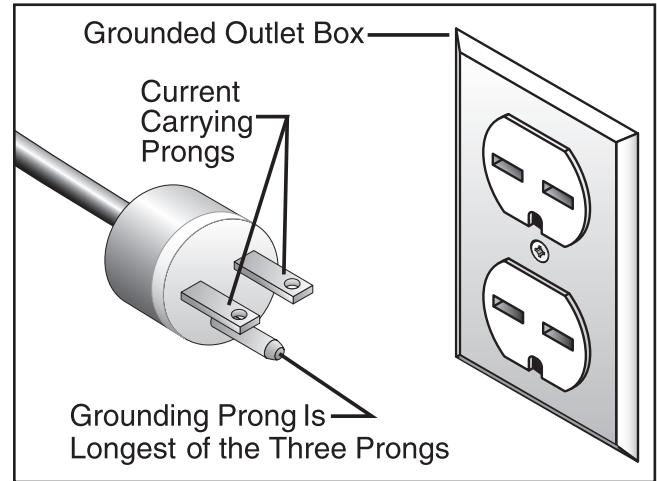

Figure 1. NEMA 6-15 plug and receptacle.

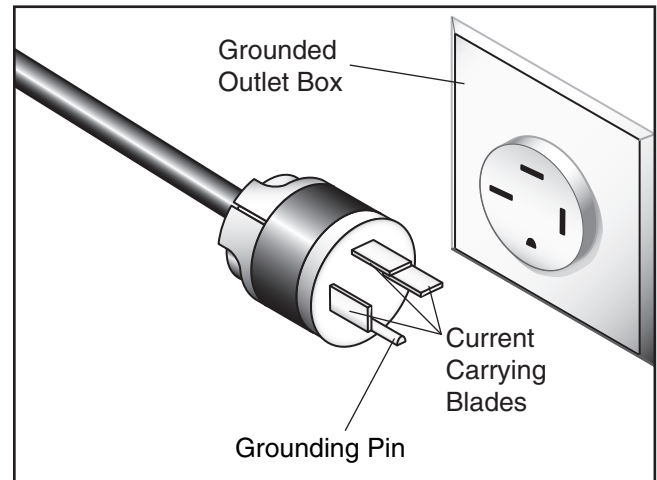
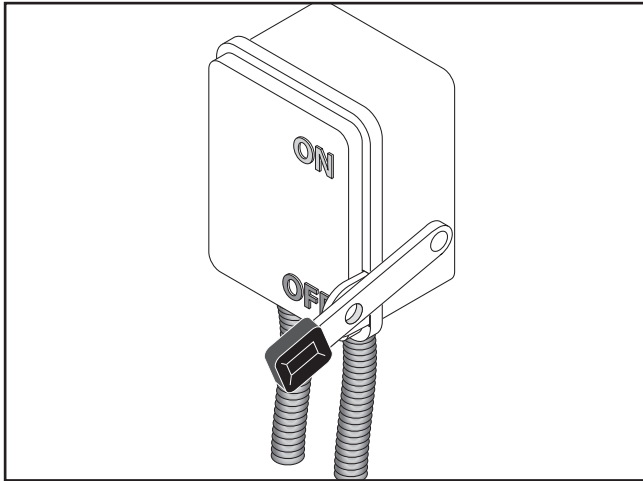
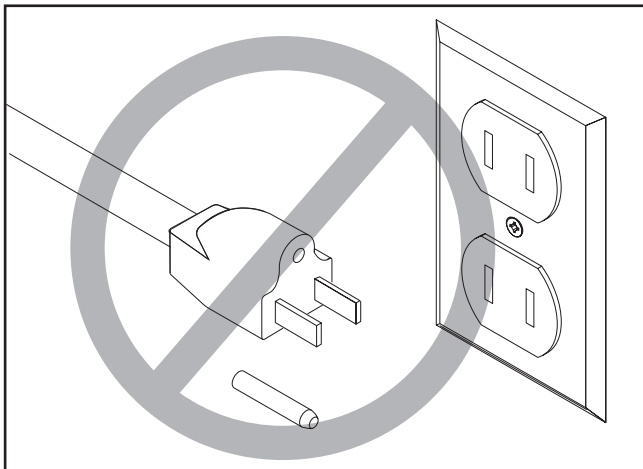

Figure 2. NEMA 15-15R plug and receptacle.





**Figure 3.** A locking shut-off switch near the machine.



## **⚠ CAUTION**

**This machine must have a ground prong in the plug to help ensure that it is grounded. DO NOT remove ground prong from plug to fit into a two-pronged outlet! If the plug will not fit the outlet, have the proper outlet installed by a qualified electrician.**

# Grounding

In the event of an electrical short, grounding reduces the risk of electric shock. The grounding wire in the power cord must be properly connected to the grounding prong on the plug; likewise, the outlet must be properly installed and grounded. All electrical connections must be made in accordance with local codes and ordinances.

# Extension Cords

We do not recommend the use of extension cords. Instead, arrange the placement of your equipment and the installed wiring to eliminate the need for extension cords.

If you find it absolutely necessary to use an extension cord with your machine, the extension cord must also contain a ground wire and plug pin.

## 110V Operation

Use at least a 12 gauge cord that does not exceed 50 feet in length!

## 220V Operation

Use at least a 12 gauge cord that does not exceed 50 feet in length!

# Phase Converter

When using a phase converter for 3-phase, the power from the manufactured power leg (sometimes called the wild wire) can fluctuate. Connect the manufactured power leg to the S terminal to prevent damage. The wire from the S terminal can handle some fluctuation because it goes directly to the motor. The power going to the R and T terminals goes to the transformer and must be consistent to prevent damage.



# SECTION 3: SET UP

## Set Up Safety

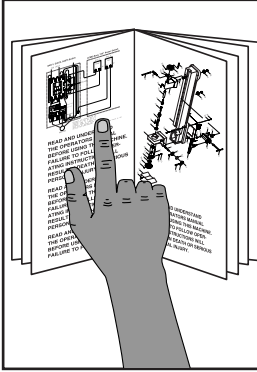

### **!WARNING**

This machine presents serious injury hazards to untrained users. Read through this entire manual to become familiar with the controls and operations before starting the machine!

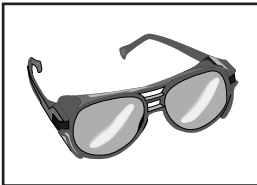

### **!WARNING**

Wear safety glasses during the entire set up process!



### **!WARNING**

The Model G0596/G0597/G0598/G0599 is a heavy machine. DO NOT over-exert yourself while unpacking or moving your machine—get assistance.

## Items Needed for Set Up

The following items are needed to complete the set up process, but are not included with your machine:

Description	Qty
• Wrench or Socket 12mm.....	1
• Wrench or Socket 8mm.....	1
• Safety Glasses (for each person) .....	1
• Phillips Screwdriver #2.....	1
• Assistant.....	1-2

## Unpacking

The Model G0596/G0597/G0598/G0599 was carefully packed when it left our warehouse. If you discover the machine is damaged after you have signed for delivery, *please immediately call Customer Service at (570) 546-9663 for advice.*

Save the containers and all packing materials for possible inspection by the carrier or its agent. *Otherwise, filing a freight claim can be difficult.*

When you are completely satisfied with the condition of your shipment, you should inventory the contents.



# Inventory

After all the parts have been removed from the box you should have the following items:

Box 1:	Qty
A. Grinder .....	1
B. Wrench 25mm (G0596/G0597).....	1
C. Wrench 50mm (G0598/G0599).....	1

## NOTICE

Some hardware/fasteners on the inventory list may arrive pre-installed on the machine. Check these locations before assuming that any items from the inventory list are missing.

# Eye Shields

The eye shields on the Model G0596/G0597/ G0598/G0599 may come pre-mounted from the factory. If they do not, attach them at this time with the two Phillips head screws provided.

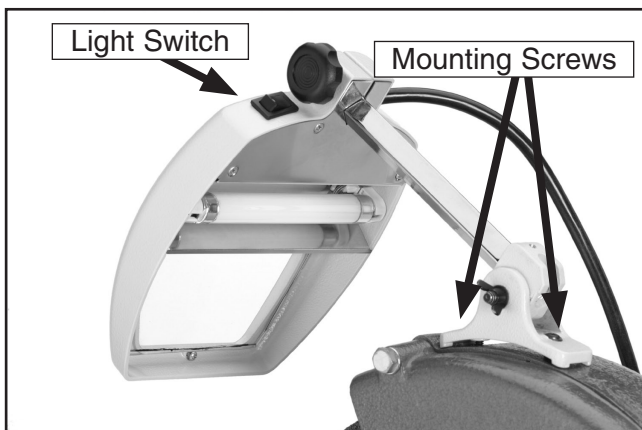

Figure 4. Eye shield.

## WARNING

DO NOT operate this grinder without the eye shields or wheel guards in place. Failure to properly use these safety devices could lead to serious injury!

# Mounting

Mount the grinder on the optional H7834 stand (see **Page 17**), or a workbench that is sturdy enough to hold the weight of the machine and any downward pressure that may be applied during operation.

The stand or workbench should be level, rigid, and attached to the floor, so it will not move during operation.

For proper safety, drill holes in your workbench and secure the grinder with hex bolts, washers, and hex nuts, or with lag screws and flat washers. (Mounting hardware is not provided due to the many possible set ups and workbench thicknesses.)

### When locating your grinder, remember:

- You will need room for potentially large workpieces.
- Maintain easy access to dust ports for attaching dust collection system.
- Grinding without dust collection system spreads dust in the immediate vicinity of the grinder.
- Grinding creates flying sparks that MUST be out of reach of any flammables.
- You will need a lot of light around the grinding wheel in addition to the lighted eye shields.

# Dust Collection

## **⚠ CAUTION**

**DO NOT** operate the Model G0596/G0597/G0598/G0599 without an adequate dust collection system. This grinder creates substantial amounts of dust while operating. Failure to use a dust collection system can result in short and long-term respiratory illness.

The Model G0596/G0597/G0598/G0599 features a dust port at the rear of the grinding wheel. If a dust collection system is not attached, both ports have spark deflectors that direct sparks downward.

### To connect a dust collection hose:

1. Remove the spark deflector.
2. Fit the dust hose over the dust port, as shown in **Figure 5**, and secure in place with a hose clamp.
3. Tug the hose to make sure it does not come off. **Note:** *A tight fit is necessary for proper performance.*

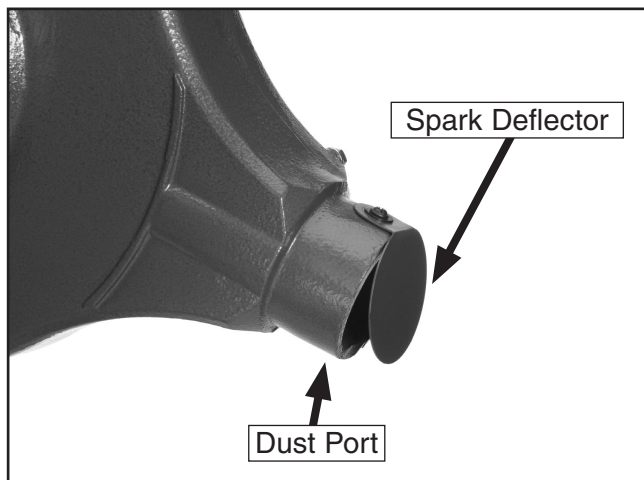

**Figure 5.** Dust port.

## **⚠ CAUTION**

**FIRE AND EXPLOSION HAZARD! DO NOT** attach dust ports to a dust collection system designed or used for wood dust collection.

# Test Run

The test run ensures that the grinder and grinder wheels were not damaged during shipping.

### To test run the grinder:

1. Review and understand all grinder safety information.
2. Remove the wheels and closely inspect the overall conditions. Follow this by performing a "Ring Test" (see **Wheel Inspection** on **Page 15** and **Wheel Replacement** on **Page 16**).
3. Plug the grinder into the power source.
4. Put on safety glasses and face shield.
5. Stand to the side of the line of the wheels rotation, turn the grinder **ON**, and allow it to run a least one minute, before standing in front of it.

—The grinder should run smoothly.

—Grinding wheels should run true without noticeable vibration.

—If there is an obvious problem with the way the grinder is running, turn it **OFF** immediately and troubleshoot the problem, using the troubleshooting table on **Page 18**. **DO NOT** operate the grinder until it is fixed.

# Hardware Recognition Chart

USE THIS CHART TO MATCH UP  
HARDWARE DURING THE ASSEMBLY  
PROCESS!

MEASURE BOLT DIAMETER BY PLACING INSIDE CIRCLE

- #10
- 1/4"
- 5/16"
- 3/8"
- 7/16"
- 1/2"

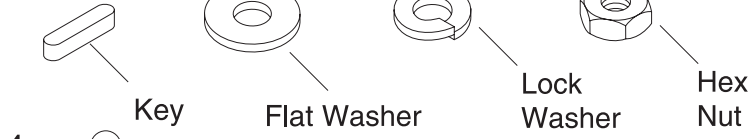
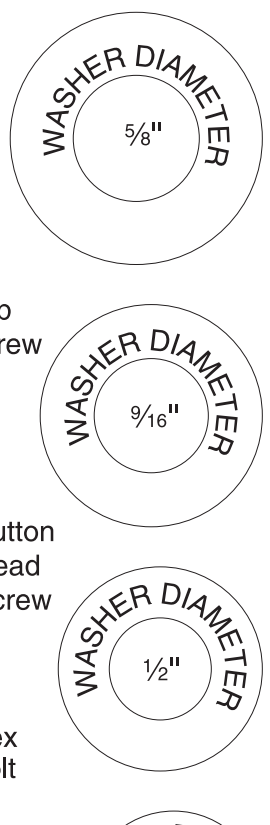
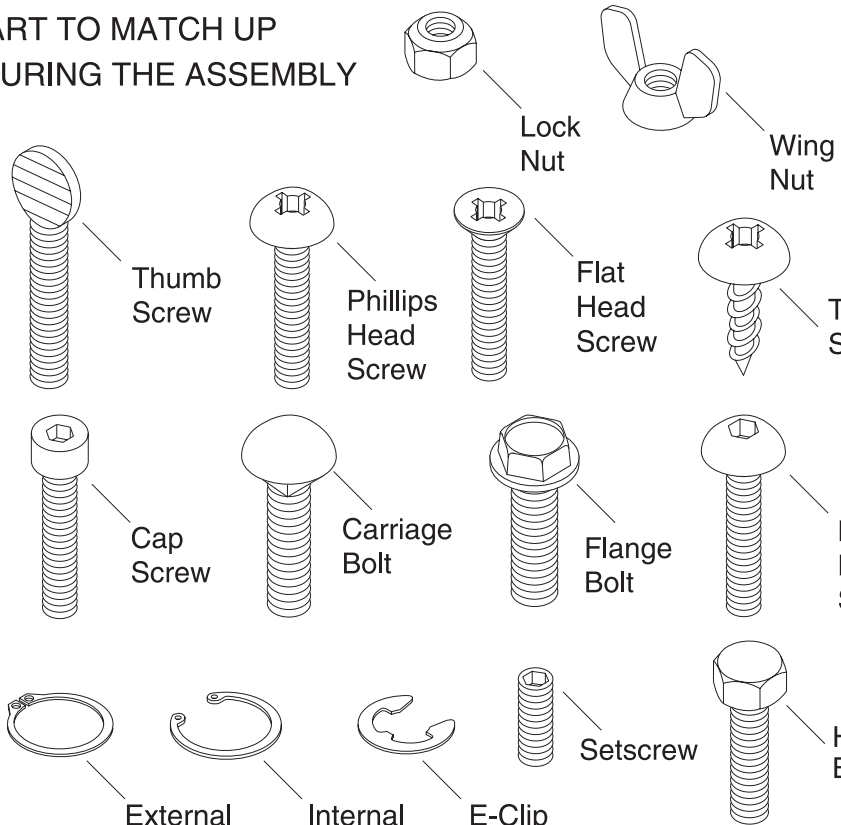

- 4mm
- 6mm
- 8mm
- 10mm
- 12mm
- 16mm

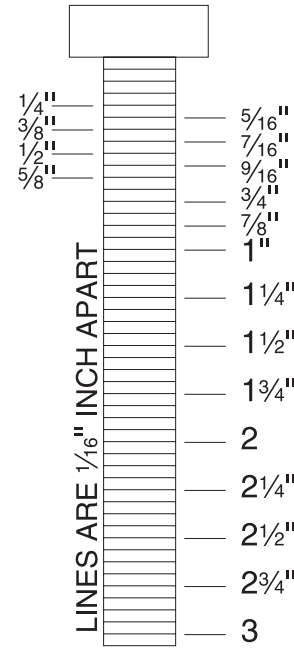
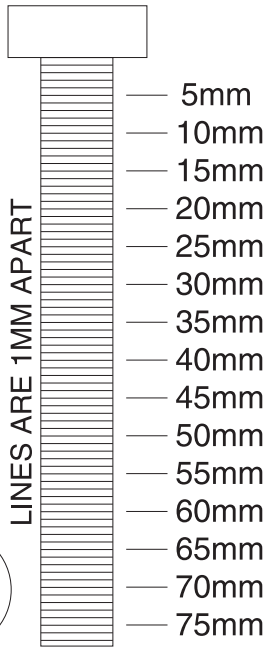

WASHERS ARE MEASURED BY THE INSIDE DIAMETER

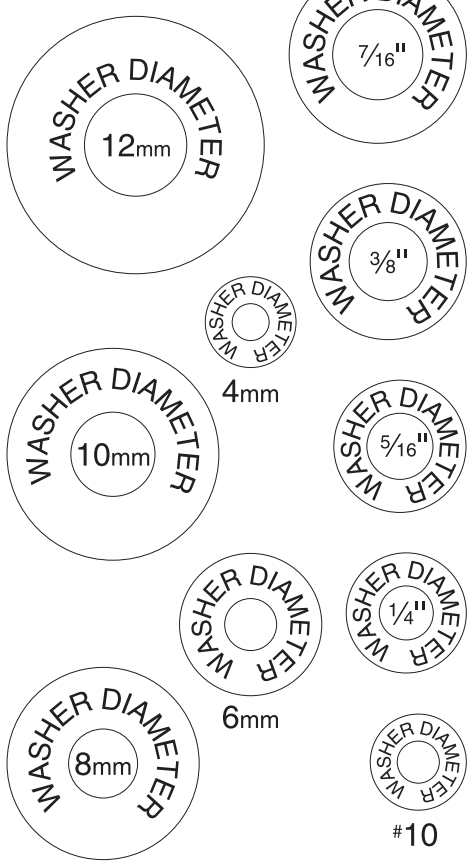



# SECTION 4: OPERATIONS

## Operation Safety

### **!WARNING**

Damage to your eyes, lungs, and ears could result from using this machine without proper protective gear. Always wear safety glasses with face shield, a respirator, and hearing protection when operating this machine.

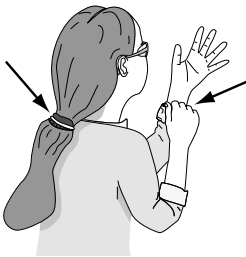
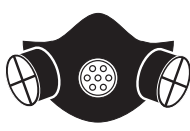

### **!WARNING**

Loose hair and clothing could get caught in machinery and cause serious personal injury. Keep loose clothing and long hair away from moving machinery.

### **NOTICE**

If you have never used this type of machine or equipment before, WE STRONGLY RECOMMEND that you read books, trade magazines, or get formal training before beginning any projects. Regardless of the content in this section, Grizzly Industrial will not be held liable for accidents caused by lack of training.

## Grinding Tips

The grinder is a safe tool when used properly. In addition to the safety instructions in this manual, the most important safety consideration is to use common sense at all times. What may be okay in one situation, may not be safe in another.

Here are some tips to keep in mind while grinding:

- DO NOT grind on the side of the wheel. The wheels provided with the Model G0596/G05967/G0598/G0599 are not designed for side grinding. Grinding on the side greatly stresses the wheel and may cause it to shatter.
- Wear the proper protective clothing. Particles flying off of a grinding wheel will be traveling very fast—prepare for this. Wear safety glasses/face shield, a dust mask, earplugs, a leather apron, and heavy leather boots.
- Make sure all guards are in place.
- Remember that grinding often produces sparks. DO NOT allow anyone to stand in the path of the sparks. DO NOT grind near flammable materials.
- Maintain proper care of your wheels. Read the **Wheel Care** on **Page 14**.
- Grasp the workpiece firmly and properly support it on the tool rest during grinding. Maintain even pressure and control of the workpiece when grinding.
- Concentrate on the task at hand. STOP grinding if you are distracted.
- DO NOT grind workpieces that are heavier than the wheel itself. This stresses the wheel. In these cases use a handheld grinder instead.





# Wheel Care

Your safety when grinding depends, on a large part, on the condition of the wheel during grinding. A wheel in poor condition presents the possibility of breaking apart during rotation and injuring the operator and others in the area.

## Here are some tips to help you avoid breaking the wheel:

- Always transport, store and handle wheels with care. Wheels may be damaged if they are dropped or if heavy objects are stacked on them.
- Select the right grinding wheel for the job. DO NOT grind material inappropriate for the wheel type.
- Select the right wheel for the machine. A machine that rotates at a higher RPM than the wheel is rated for may cause the wheel to fly apart.
- Mount the wheels properly. (See the **Wheel Replacement** instructions on **Page 16** for guidance.)
- Do not abuse the wheel by jamming the work into the grinding wheel with excessive force that causes the grinder to bog down, or apply pressure to stop the wheel after turning the grinder **OFF**.
- Dress the wheel when necessary. Do not allow it to become glazed.
- Always spin water/coolant out of the wheel before turning the grinder **OFF**. This may take 5–10 minutes. (If moisture is left on the wheel, the wheel may warp.)
- Do not store wheels in damp or wet locations.
- Do not grind on the side of the wheel unless wheel is designed for side grinding.
- Do not overtighten the nut when mounting the wheel.

# Wheel Selection

The Model G0596/G0597 only accepts Type 1 wheels with a 1" bore. The Model G0598/G0599 only accepts Type 1 wheels with a 1¼" bore.

Aluminum oxide and silicon carbide wheels are marked in a somewhat uniform manner by all the major manufacturers. Understanding these markings will help you understand the capabilities of various wheels. Always refer to the manufacturer's grinding recommendations when selecting a wheel for your project.

## The basic format for wheel numbering is:

Prefix	Abrasive Type	Grit Size	Grade	Bond Type
1	A	60	L	V

The **Prefix** is the manufacturer's designation for a particular wheel type (eg, Type 1 wheels).

The most common **Abrasive Types** used are A for Aluminum Oxide, C for Silicon Carbide, and occasionally SG for Seeded Gel.

The **Grit Size** is a number that refers to the size of the abrasive grain in the wheel. The lower the number, the coarser the wheel. Ten is a very coarse wheel for roughing and 220 is usually the upper range for fine finish work.

**Grade** is an indication of the hardness of the wheel—"A" being the softest and "Z" being the hardest.

**Bond Type** refers to the type of bonding material used to hold the abrasive material. Most general purpose wheels will have a "V" indicating Vitrified Clay is used. Vitrified Clay provides high strength and good porosity. The other common bond type is "B" for resin where synthetic resins are used. These are used to grind cemented carbide and ceramic materials.

**Note:** *There may be other numbers inserted that have meaning for a particular type of wheel. Refer to the manufacturer's technical data for a complete explanation.*



# Wheel Inspection

Before mounting a new grinding wheel, it must be inspected. Do not assume that a wheel is in sound condition just because it is new—often damage can occur in shipping, with age, or with exposure to moisture.

First, do a **Visual Inspection**. Look for any cracks, chips, nicks or dents in the surface of the wheel. If you see any of these, **DO NOT** use the wheel.

Second, do a **Ring Test**. This test will give you an indication of any internal damage that may not be obvious during a visual inspection.

## To perform a Ring Test:

1. Make sure the wheel that you test is clean and dry; otherwise, you may get false results.
2. If size permits, balance the wheel with your finger in the hole. If this is not possible, hang the wheel in the air with a piece of cord or string looped through the hole in the center.
3. At the spots shown in **Figure 6**, gently tap the wheel with a light non-metallic device such as the handle of a screwdriver or a wooden mallet.

**Note:** Finding the exact spot to tap will take several attempts.

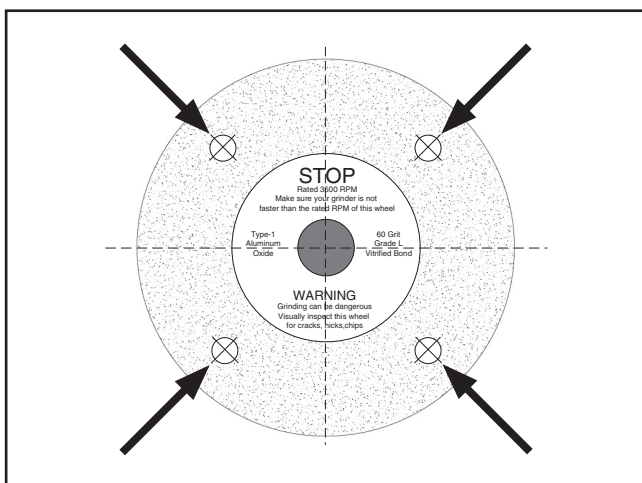

**Figure 6.** Tapping locations when performing a ring test.

4. An undamaged wheel will emit a clear metallic ring or “ping” sound in each of these spots. A damaged wheel will respond with a dull thud that has no clear tone.
5. If you determine from the ring test that the wheel is damaged, **DO NOT** use it!

# Wheel Dressing

Depending on the type of grinding you do, the grinding wheel may require periodic dressing.

There are several different types of wheel dressing devices available on the market (see **Page 17**). Dressing restores the abrasive quality of the wheel surface and brings the wheel edge back to a square form.

Refer to the instructions that accompany your dressing accessory for complete details on how to properly dress a wheel.

# Wheel Replacement

## **⚠ CAUTION**

**ALWAYS** visually inspect and perform a “ring test” on a wheel before assembly. **DO NOT** use damaged wheels!

The wheel guard must be removed in order to mount or dismount a grinding wheel.

### To replace a grinding wheel:

1. UNPLUG THE GRINDER!
2. Remove the wheel guard.
3. Use a wrench on the arbor nut. Hold the wheel from turning with your other hand. Note that the wheel on the left-hand side of the machine has left-handed threads, so the arbor nut on that side must be turned clockwise to loosen.
4. Remove the outer wheel flange and the paper disc. Pull the wheel free from the arbor. There will also be a paper disc and a wheel flange on the other side of the wheel.
5. Mount the new wheel as shown in **Figure 7**. Always make certain there is a paper or fiber disc between the wheel flanges and the wheel itself. Tighten the nut snugly but **DO NOT** over-tighten. Over-tightening can crack the wheel (see **Figure 8**).

## **⚠ CAUTION**

**NEVER** assemble a grinding wheel on the arbor without paper or fiber discs between the wheel and the flange. Not using the discs can put stress on the wheel, causing it to crack and possibly fall apart.

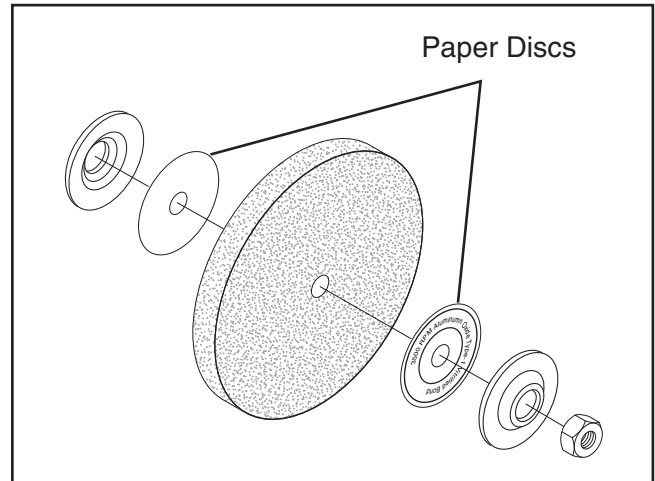

**Figure 7.** Assembly order for wheel installation.

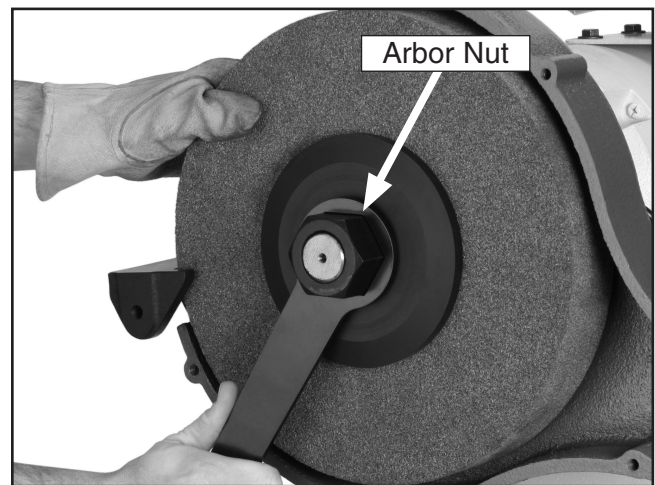

**Figure 8.** Nut removal/tightening.

6. Re-install the wheel guard.
7. Run a new wheel for at least one minute while standing clear of the line of rotation. If a wheel does have defects it will generally fail within that time.

# SECTION 5: ACCESSORIES

## G0596 Replacement Wheels

Model H8880—8 x 1 x 1" Al Oxide 24 Grit

Model H8881—8 x 1 x 1" Al Oxide 36 Grit

## G0597 Replacement Wheels

Model H8882—10 x 1 x 1" Al Oxide 24 Grit

Model H8883—10 x 1 x 1" Al Oxide 36 Grit

## G0598 Replacement Wheels

Model H8884—12 x 1½ x 1¼" Al Oxide 24 Grit

Model H8885—12 x 1½ x 1¼" Al Oxide 36 Grit

## G0599 Replacement Wheels

Model H8886—12 x 2 x 1¼" Al Oxide 24 Grit

Model H8887—12 x 2 x 1¼" Al Oxide 36 Grit



Model H5891—¼ Carat Diamond Dresser

Model H5892—¾ Carat Diamond Dresser

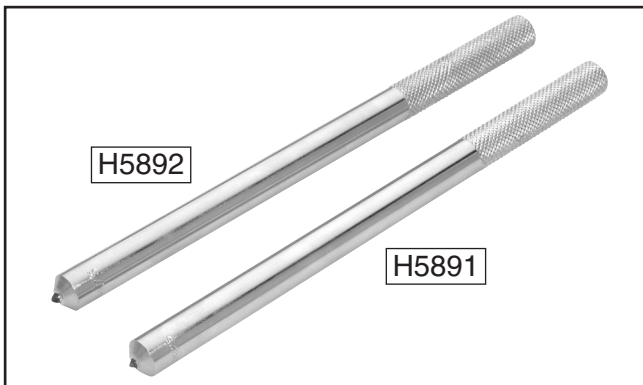

Model H7834—34½" Stand for Industrial Bench Grinders.



Model H5944—#0 Wheel Dresser

Model H5945—#1 Wheel Dresser

Model H5946—#2 Wheel Dresser



Model G3446—Accu-Sharp Jigs

Model G4570—Accu-Sharp Stubby Chisel Jig

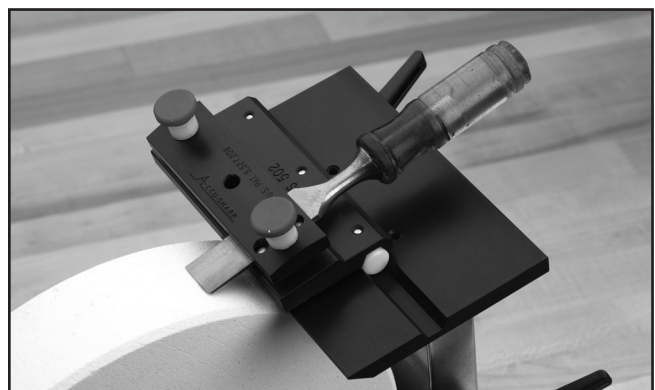

Call 1-800-523-4777 To Order

G0596-G0599 Industrial Bench Grinders



# SECTION 6: SERVICE

Review the troubleshooting and procedures in this section to fix your machine if a problem develops. If you need replacement parts or you are unsure of your repair skills, then feel free to call our Technical Support at (570) 546-9663.

## Troubleshooting

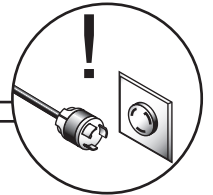

### Motor & Electrical

Symptom	Possible Cause	Possible Solution
Motor will not start.	<ol style="list-style-type: none"> <li>1. Low voltage.</li> <li>2. Open circuit in motor or loose connections.</li> </ol>	<ol style="list-style-type: none"> <li>1. Check power line for proper voltage.</li> <li>2. Inspect all lead connections on motor for loose or open connections.</li> </ol>
Motor will not start; fuses or circuit breakers blow.	<ol style="list-style-type: none"> <li>1. Short circuit in line cord or plug.</li> <li>2. Short circuit in motor or loose connections.</li> <li>3. Incorrect fuses or circuit breakers in power line.</li> </ol>	<ol style="list-style-type: none"> <li>1. Inspect cord or plug for damaged insulation and shorted wires.</li> <li>2. Inspect all connections on motor for loose or shorted terminals or worn insulation.</li> <li>3. Install correct fuses or circuit breakers.</li> </ol>
Motor overheats.	<ol style="list-style-type: none"> <li>1. Motor overloaded.</li> </ol>	<ol style="list-style-type: none"> <li>1. Reduce load on motor.</li> </ol>
Motor stalls (resulting in blown fuses or tripped circuit).	<ol style="list-style-type: none"> <li>1. Short circuit in motor or loose connections.</li> <li>2. Low voltage.</li> <li>3. Incorrect fuses or circuit breakers in power line.</li> <li>4. Motor overloaded.</li> </ol>	<ol style="list-style-type: none"> <li>1. Inspect connections on motor for loose or shorted terminals or worn insulation.</li> <li>2. Correct the low voltage conditions.</li> <li>3. Install correct fuses or circuit breakers.</li> <li>4. Reduce load on motor.</li> </ol>
Machine slows when operating.	<ol style="list-style-type: none"> <li>1. Operator is using too much pressure.</li> </ol>	<ol style="list-style-type: none"> <li>1. Use less pressure when grinding.</li> </ol>
Wavy condition on surface of workpiece.	<ol style="list-style-type: none"> <li>1. Machine vibrating.</li> <li>2. Workpiece not being held firmly.</li> <li>3. Wheel face uneven.</li> <li>4. Wheel is too hard.</li> </ol>	<ol style="list-style-type: none"> <li>1. Make sure machine is securely mounted on a solid surface.</li> <li>2. Use a holding device to firmly retain the workpiece.</li> <li>3. Dress the grinding wheel.</li> <li>4. Use softer wheel, or reduce the feed rate.</li> </ol>
Lines on surface of workpiece.	<ol style="list-style-type: none"> <li>1. Impurity on wheel surface.</li> <li>2. Workpiece not being held tightly.</li> </ol>	<ol style="list-style-type: none"> <li>1. Dress the grinding wheel.</li> <li>2. Use a holding device to firmly retain the workpiece.</li> </ol>
Burning spots or cracks in the workpiece.	<ol style="list-style-type: none"> <li>1. Improper type of grinding wheel.</li> <li>2. Improper feed rate.</li> <li>3. Coolant required.</li> </ol>	<ol style="list-style-type: none"> <li>1. Try a wheel which is softer style or a coarser grit.</li> <li>2. Slow down the rate of movement of the workpiece into wheel.</li> <li>3. Add optional coolant system or introduce coolant by hand.</li> </ol>
Wheel dulls quickly, grit falls off.	<ol style="list-style-type: none"> <li>1. Depth of cut too great.</li> <li>2. Wheel is too soft.</li> <li>3. Wheel diameter too small.</li> <li>4. Bad wheel dress.</li> <li>5. Defective wheel bonding.</li> </ol>	<ol style="list-style-type: none"> <li>1. Slow down the rate of movement of the workpiece into wheel.</li> <li>2. Wheel too soft for the material being ground, select harder bond.</li> <li>3. Replace the wheel.</li> <li>4. Dress the wheel.</li> <li>5. Consult manufacturer of grinding wheel.</li> </ol>



# 110V Wiring Diagram G0596 Single Phase

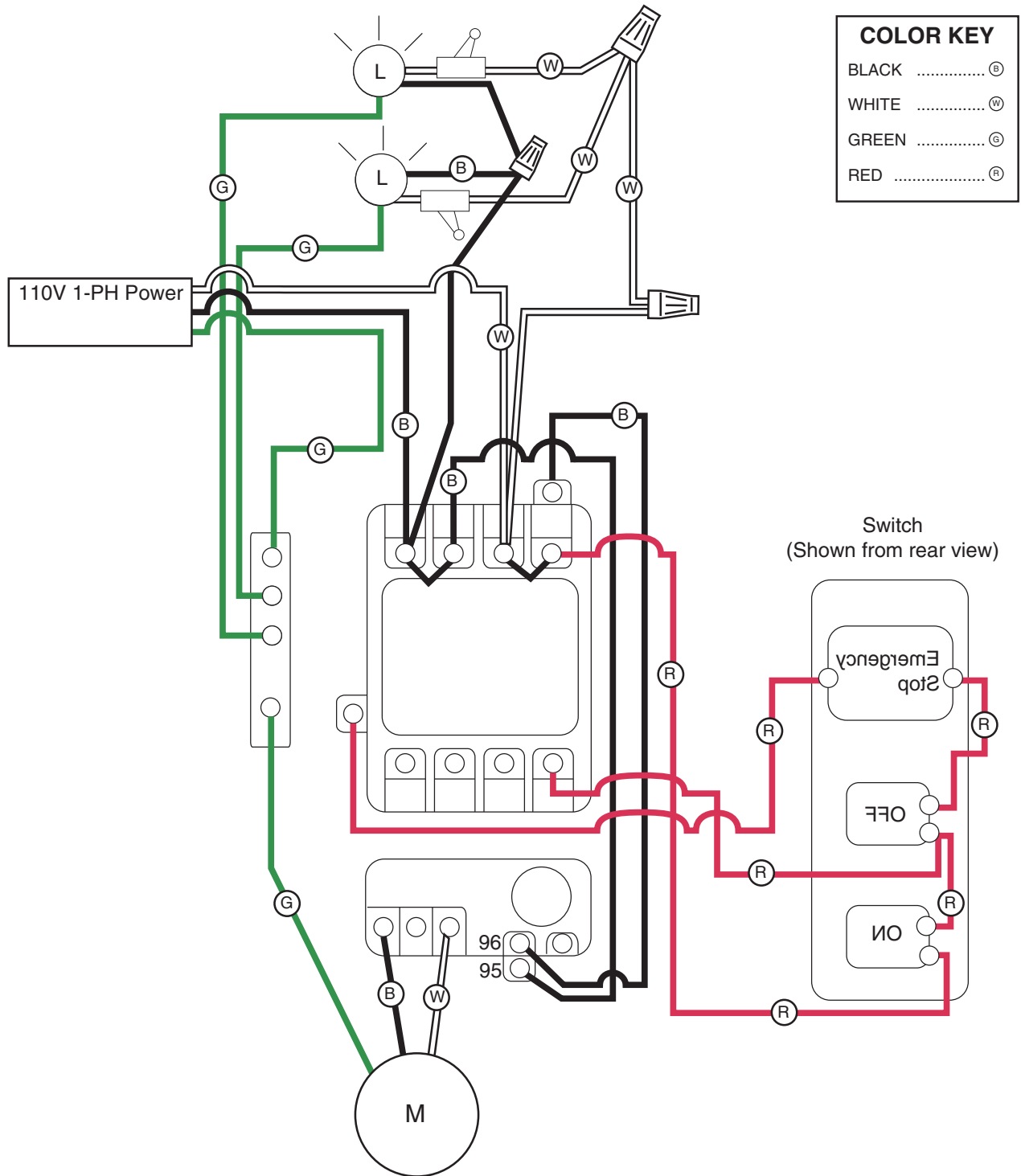



# 220V Wiring Diagram G0597/G0598 Single Phase

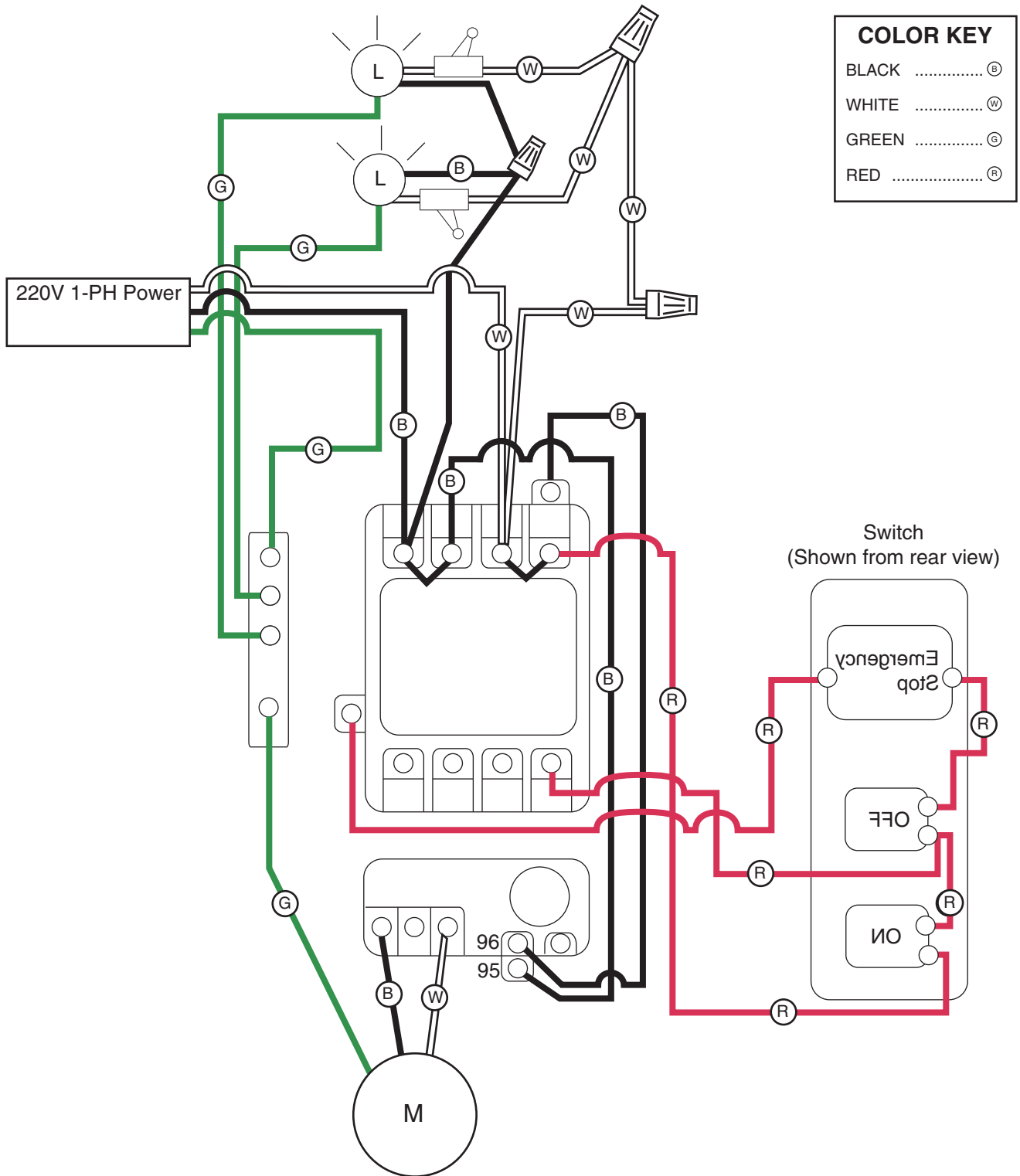



# 220V Wiring Diagram G0599 3-Phase

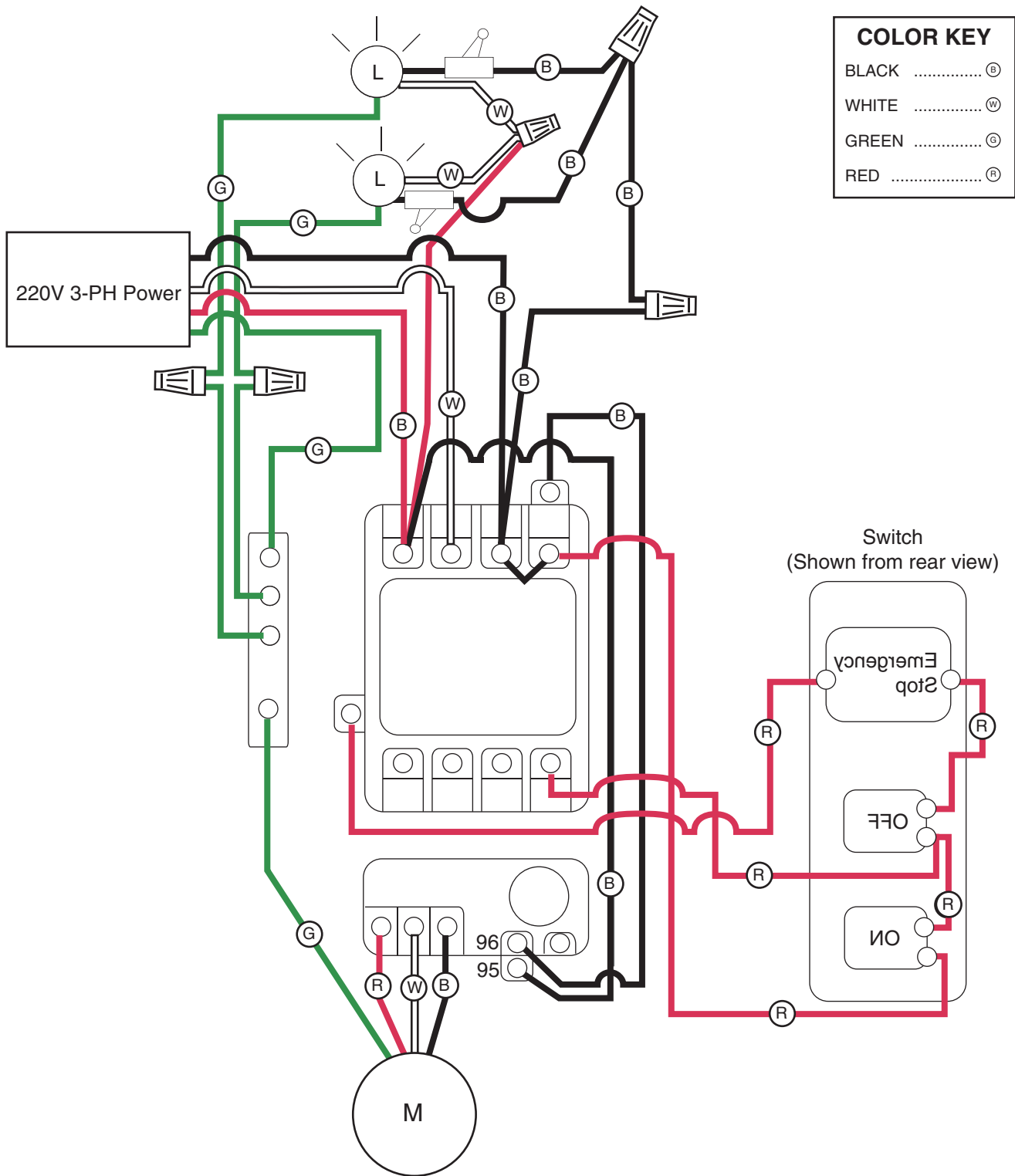

# Parts Breakdown Main

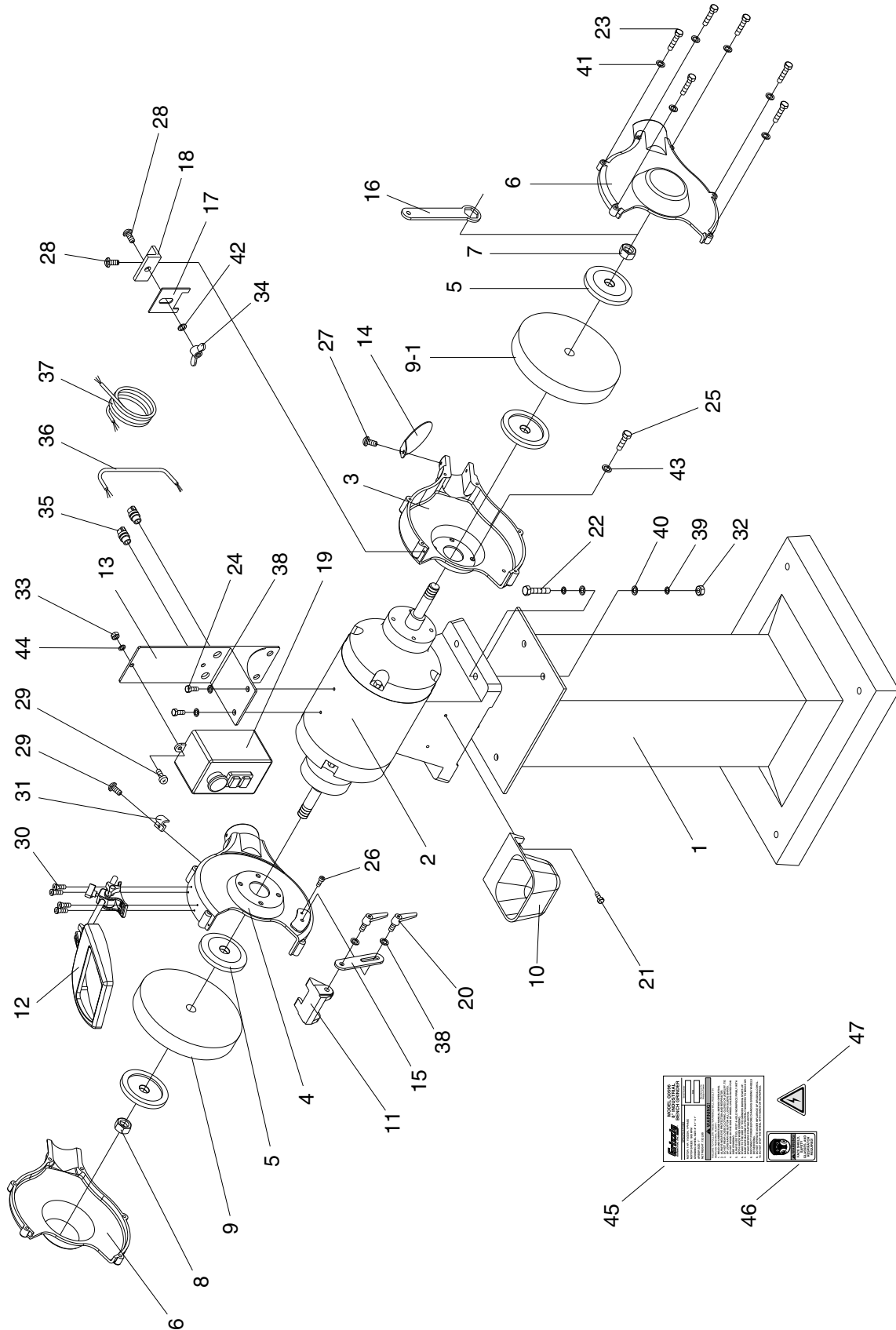

# Parts Breakdown Shield

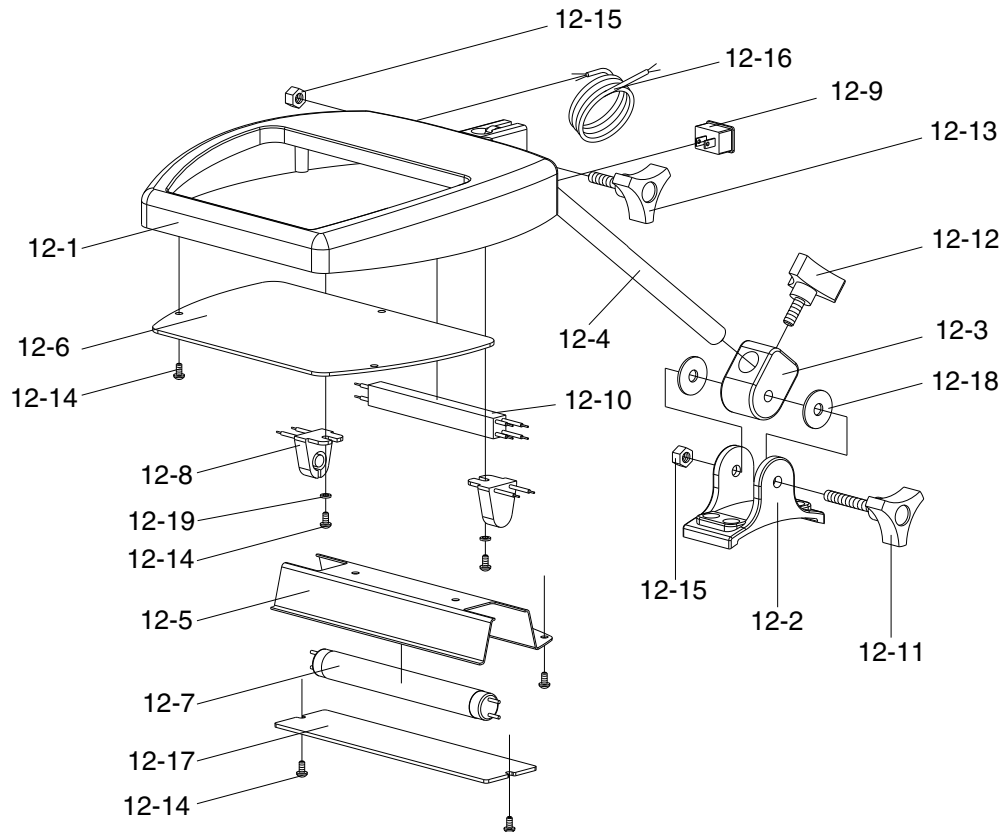

## WARNING

Safety labels warn about machine hazards and ways to prevent injury. The owner of this machine **MUST** maintain the original location and readability of the labels on the machine. If any label is removed or becomes unreadable, **REPLACE** that label before using the machine again. Contact Grizzly at (800) 523-4777 or [www.grizzly.com](http://www.grizzly.com) to order new labels.



# Parts List G0596-G0597

REF	PART #	DESCRIPTION
1	H7834	STAND (OPTIONAL)
2	P0596002	MOTOR 1HP,110,1PH (G0596)
2-1	P0596002-1	CAPACITOR 30MFD-250VAC
2	P0597002	MOTOR 1.5HP, 220V,1PH (G0597)
2-1	P0597002-1	CAPACITOR 50MFD-250VAC
3	P0596003	WHEEL GUARD, RIGHT (G0596)
3	P0597003	WHEEL GUARD, RIGHT (G0597)
4	P0596004	WHEEL GUARD, LEFT (G0596)
4	P0597004	WHEEL GUARD, LEFT (G0597)
5	P0596005	WHEEL FLANGE
6	P0596006	WHEEL COVER (G0596)
6	P0597006	WHEEL COVER (G0597)
7	PN22	HEX NUT 1-8 (G0596-G0597)
8	PN18	HEX NUT 1-8 LH (G0596-G0597)
9	H8880	WHEEL 8 X 1 X 1, 24 GRIT
9-1	H8881	WHEEL 8 X 1 X 1, 36 GRIT
9	H8882	WHEEL 10 X 1 X 1, 24 GRIT
9-1	H8883	WHEEL 10 X 1 X 1, 36 GRIT
10	P0596010	WATER TRAY
11	P0596011	TOOL REST
12	P0596012	EYE SHIELD ASSY (G0596)
12	P0597012A	EYE SHIELD ASSY (G0597-G0599)
12-1	P0596012-1	FRAME
12-2	P0596012-2	MOUNT
12-3	P0596012-3	PIVOT SUPPORT
12-4	P0596012-4	ARM
12-5	P0596012-5	BAFFLE
12-6	P0596012-6	CLEAR SHIELD
12-7	P0596012-7	FLUORESCENT TUBE (G0596)
12-7	P0597012-7	FLUORESCENT TUBE (G0597)
12-8	P0596012-8	LAMP CONTACT
12-9	P0596012-9	SWITCH
12-10	P0596012-10	BALLAST (G0596)
12-10	P0597012-10	BALLAST (G0597)
12-11	P0596012-11	KNOB 1/4-20 X 1-3/4
12-12	P0596012-12	KNOB 1/4-20 X 1/2
12-13	P0596012-13	KNOB 1/4-20 X 1
12-14	PHTEK33	TAP SCREW 8-32 X 1/4
12-15	PN05	HEX NUT 1/4-20
12-16	P0596012-16	POWER SUPPLY CORD

REF	PART #	DESCRIPTION
12-17	P0596012-17	LAMP COVER
12-18	P0596012-18	SPECIAL WASHER
12-19	PW08	FLAT WASHER #8
13	P0596013	SWITCH BRACKET
14	P0596014	SPARK HOOD
15	P0596015	TOOL REST SUPPORT
16	P0596016	WRENCH 25MM (G0596-G0597)
17	P0596017	SPARK SHIELD (G0596-G0597)
18	P0596018	SPARK SHIELD BRACKET
19	P0596019	MAGNETIC SWITCH (G0596)
19	P0597019	MAGNETIC SWITCH (G0597)
20	P0596020	HANDLE 5/16-18 X 5/8
21	PFB13	FLANGE BOLT 1/4-20 X 1
22	PB58	HEX BOLT 3/8-16 X 2
23	PB155	HEX BOLT 10-24 X 1-1/4
24	PB09	HEX BOLT 5/16-18 X 1/2
25	PB07M	HEX BOLT M8-1.25 X 25
26	PSB17	CAP SCREW 1/4-20 X 3/8
27	PS06	PHLP HD SCR 10-24 X 3/8
28	PS04	PHLP HD SCR 1/4-20 X 1/2
29	PS01	PHLP HD SCR 10-24 X 1/2
30	PFH21	FLAT HD SCR 10-24 X 3/4
31	P0596031	NYLON CLIP 8MM
32	PN08	HEX NUT 3/8-16
33	PN05	HEX NUT 1/4-20
34	PWN02	WING NUT 1/4-20
35	P0596035	STRAIN RELIEF
36	P0596036	MOTOR CORD
37	P0596037	POWER CORD
38	PW07	FLAT WASHER 5/16
39	PLW04	LOCK WASHER 3/8
40	PW02	FLAT WASHER 3/8
41	PLW03	LOCK WASHER 3/16
42	PW06	FLAT WASHER 1/4
43	PLW04M	LOCK WASHER 8MM
44	PLW03	LOCK WASHER 3/16
45	P0596045	MACHINE ID LABEL (G0596)
45	P0597045	MACHINE ID LABEL (G0597)
46	P0596046	FACE SHEILD LABEL
47	PLABEL-14	ELECTRICITY LABEL



# Parts List G0598-G0599

REF	PART #	DESCRIPTION
1	H7834	STAND (OPTIONAL)
2	P0598002	MOTOR 2HP, 1PH, 220V(G0598)
2-1	P0597002-1	CAPACITOR 50MFD-250VAC
2	P0599002	MOTOR 3HP, 3PH, 220V(G0599)
3	P0598003	WHEEL GUARD, RIGHT
4	P0598004	WHEEL GUARD, LEFT
5	P0598005	WHEEL FLANGE
6	P0598006	WHEEL COVER
7	PN36	HEX NUT 1-1/4-7 (G0598-G0599)
8	PN37	HEX NUT 1-1/4-7 LH (G0598-G0599)
9	H8884	WHEEL 12 X 1.5 X1-1/4, 24 GRIT
9-1	H8885	WHEEL 12 X 1.5 X1-1/4, 36 GRIT
9	H8885	WHEEL 12 X 2 X 1-1/4, 24 GRIT
9-1	H8887	WHEEL 12 X 2 X 1-1/4, 36 GRIT
10	P0596010	WATER TRAY
11	P0598011	TOOL REST (G0598)
11	P0599011	TOOL REST (G0599)
12	P0597012A	EYE SHIELD W/ LIGHT ASSY
12-1	P0596012-1	FRAME
12-2	P0596012-2	MOUNT
12-3	P0596012-3	PIVOT SUPPORT
12-4	P0596012-4	ARM
12-5	P0596012-5	BAFFLE
12-6	P0596012-6	CLEAR SHIELD
12-7	P0597012-7	FLUORESCENT TUBE
12-8	P0596012-8	LAMP CONTACT
12-9	P0596012-9	SWITCH
12-10	P0597012-10	BALLAST
12-11	P0596012-11	KNOB 1/4-20 X 1-3/4
12-12	P0596012-12	KNOB 1/4-20 X 1/2
12-13	P0596012-13	KNOB 1/4-20 X 1
12-14	PHTEK33	TAP SCREW 8-32 X 1/4
12-15	PN05	HEX NUT 1/4-20
12-16	P0596012-16	POWER SUPPLY CORD
12-17	P0596012-17	LAMP COVER
12-18	P0596012-18	SPECIAL WASHER
12-19	PW08	FLAT WASHER #8
13	P0596013	SWITCH BRACKET

REF	PART #	DESCRIPTION
14	P0596014	SPARK HOOD
15	P0598015	TOOL REST SUPPORT
16	P0598016	WRENCH 50MM (G0598-G0599)
17	P0598017	SPARK SHIELD(G0598)
17	P0599017	SPARK SHIELD(G0599)
18	P0596018	SPARK SHIELD BRACKET
19	P0598019	MAGNETIC SWITCH 2HP(G0598)
19	P0599019	MAGNETIC SWITCH 3HP(G0599)
20	P0596020	HANDLE 5/16-18 X 5/8
21	PFB13	FLANGE BOLT 1/4-20 X 1
22	PB58	HEX BOLT 3/8-16 X 2
23	PB93	HEX BOLT 10-24 X 1-1/2
24	PB09	HEX BOLT 5/16-18 X 1/2
25	PB07M	HEX BOLT M8-1.25 X 25
26	PSB17	CAP SCREW 1/4-20 X 3/8
27	PS06	PHLP HD SCR 10-24 X 3/8
28	PS04	PHLP HD SCR 1/4-20 X 1/2
29	PS01	PHLP HD SCR 10-24 X 1/2
30	PFH21	FLAT HD SCR 10-24 X 3/4
31	P0596031	NYLON CLIP 8MM
32	PN08	HEX NUT 3/8-16
33	PN05	HEX NUT 1/4-20
34	PWN02	WING NUT 1/4-20
35	P0596035	STRAIN RELIEF
36	P0598036	MOTOR CORD
37	P0598037	POWER CORD
38	PW07	FLAT WASHER 5/16
39	PLW04	LOCK WASHER 3/8
40	PW02	FLAT WASHER 3/8
41	PLW03	LOCK WASHER 3/16
42	PW06	FLAT WASHER 1/4
43	PLW04M	LOCK WASHER 8MM
44	PLW03	LOCK WASHER 3/16
45	P0598045	MACHINE ID LABEL (G0598)
45	P0599045	MACHINE ID LABEL (G0599)
46	P0596046	FACE SHIELD LABEL
47	PLABEL-14	ELECTRICITY LABEL



# WARRANTY AND RETURNS

---

Grizzly Industrial, Inc. warrants every product it sells for a period of **1 year** to the original purchaser from the date of purchase. This warranty does not apply to defects due directly or indirectly to misuse, abuse, negligence, accidents, repairs or alterations or lack of maintenance. This is Grizzly's sole written warranty and any and all warranties that may be implied by law, including any merchantability or fitness, for any particular purpose, are hereby limited to the duration of this written warranty. We do not warrant or represent that the merchandise complies with the provisions of any law or acts unless the manufacturer so warrants. In no event shall Grizzly's liability under this warranty exceed the purchase price paid for the product and any legal actions brought against Grizzly shall be tried in the State of Washington, County of Whatcom.

We shall in no event be liable for death, injuries to persons or property or for incidental, contingent, special, or consequential damages arising from the use of our products.

To take advantage of this warranty, contact us by mail or phone and give us all the details. We will then issue you a "Return Number," which must be clearly posted on the outside as well as the inside of the carton. We will not accept any item back without this number. Proof of purchase must accompany the merchandise.

The manufacturers reserve the right to change specifications at any time because they constantly strive to achieve better quality equipment. We make every effort to ensure that our products meet high quality and durability standards and we hope you never need to use this warranty.

Please feel free to write or call us if you have any questions about the machine or the manual.

Thank you again for your business and continued support. We hope to serve you again soon.





# WARRANTY CARD

Name \_\_\_\_\_  
 Street \_\_\_\_\_  
 City \_\_\_\_\_ State \_\_\_\_\_ Zip \_\_\_\_\_  
 Phone # \_\_\_\_\_ Email \_\_\_\_\_ Invoice # \_\_\_\_\_  
 Model # \_\_\_\_\_ Order # \_\_\_\_\_ Serial # \_\_\_\_\_

The following information is given on a voluntary basis. It will be used for marketing purposes to help us develop better products and services. **Of course, all information is strictly confidential.**

1. How did you learn about us?

Advertisement                       Friend                       Catalog  
 Card Deck                               Website                       Other:

2. Which of the following magazines do you subscribe to?

<input type="checkbox"/> Cabinet Maker	<input type="checkbox"/> Popular Mechanics	<input type="checkbox"/> Today's Homeowner
<input type="checkbox"/> Family Handyman	<input type="checkbox"/> Popular Science	<input type="checkbox"/> Wood
<input type="checkbox"/> Hand Loader	<input type="checkbox"/> Popular Woodworking	<input type="checkbox"/> Wooden Boat
<input type="checkbox"/> Handy	<input type="checkbox"/> Practical Homeowner	<input type="checkbox"/> Woodshop News
<input type="checkbox"/> Home Shop Machinist	<input type="checkbox"/> Precision Shooter	<input type="checkbox"/> Woodsmith
<input type="checkbox"/> Journal of Light Cont.	<input type="checkbox"/> Projects in Metal	<input type="checkbox"/> Woodwork
<input type="checkbox"/> Live Steam	<input type="checkbox"/> RC Modeler	<input type="checkbox"/> Woodworker West
<input type="checkbox"/> Model Airplane News	<input type="checkbox"/> Rifle	<input type="checkbox"/> Woodworker's Journal
<input type="checkbox"/> Modeltec	<input type="checkbox"/> Shop Notes	<input type="checkbox"/> Other:
<input type="checkbox"/> Old House Journal	<input type="checkbox"/> Shotgun News	

3. What is your annual household income?

\$20,000-\$29,000                       \$30,000-\$39,000                       \$40,000-\$49,000  
 \$50,000-\$59,000                       \$60,000-\$69,000                       \$70,000+

4. What is your age group?

20-29                                       30-39                                       40-49  
 50-59                                       60-69                                       70+

5. How long have you been a woodworker/metalworker?

0-2 Years                       2-8 Years                       8-20 Years                       20+ Years

6. How many of your machines or tools are Grizzly?

0-2                       3-5                       6-9                       10+

7. Do you think your machine represents a good value?

Yes                       No

8. Would you recommend Grizzly Industrial to a friend?

Yes                       No

9. Would you allow us to use your name as a reference for Grizzly customers in your area?

**Note:** We never use names more than 3 times.

Yes                       No

10. Comments: \_\_\_\_\_

\_\_\_\_\_  
 \_\_\_\_\_

CUT ALONG DOTTED LINE



FOLD ALONG DOTTED LINE

\_\_\_\_\_

\_\_\_\_\_

\_\_\_\_\_



Place  
Stamp  
Here



**GRIZZLY INDUSTRIAL, INC.**  
P.O. BOX 2069  
BELLINGHAM, WA 98227-2069



FOLD ALONG DOTTED LINE

Send a Grizzly Catalog to a friend:

Name _____
Street _____
City _____ State _____ Zip _____

TAPE ALONG EDGES--PLEASE DO NOT STAPLE



# *grizzly.com*

**TOOL WEBSITE**

Buy Direct and Save with Grizzly® – Trusted, Proven and a Great Value!

*Visit Our Website Today And Discover  
Why Grizzly® Is The Industry Leader!*

- SECURE ORDERING
- ORDERS SHIPPED WITHIN 24 HOURS
- E-MAIL RESPONSE WITHIN ONE HOUR

-OR-

Call Today For A **FREE**  
Full Color Catalog

**1-800-523-4777**



## Free Manuals Download Website

<http://myh66.com>

<http://usermanuals.us>

<http://www.somanuals.com>

<http://www.4manuals.cc>

<http://www.manual-lib.com>

<http://www.404manual.com>

<http://www.luxmanual.com>

<http://aubethermostatmanual.com>

Golf course search by state

<http://golfingnear.com>

Email search by domain

<http://emailbydomain.com>

Auto manuals search

<http://auto.somanuals.com>

TV manuals search

<http://tv.somanuals.com>