

# *Grizzly* *Industrial, Inc.*®

## MODEL G0462 WOOD LATHE w/DIGITAL READOUT OWNER'S MANUAL



COPYRIGHT © APRIL, 2010 BY GRIZZLY INDUSTRIAL, INC.  
**WARNING: NO PORTION OF THIS MANUAL MAY BE REPRODUCED IN ANY SHAPE  
OR FORM WITHOUT THE WRITTEN APPROVAL OF GRIZZLY INDUSTRIAL, INC.**  
FOR MODELS MANUFACTURED SINCE 3/10 #TS12792 PRINTED IN CHINA

# **WARNING!**

**This manual provides critical safety instructions on the proper setup, operation, maintenance and service of this machine/equipment.**

**Failure to read, understand and follow the instructions given in this manual may result in serious personal injury, including amputation, electrocution or death.**

**The owner of this machine/equipment is solely responsible for its safe use. This responsibility includes but is not limited to proper installation in a safe environment, personnel training and usage authorization, proper inspection and maintenance, manual availability and comprehension, application of safety devices, blade/cutter integrity, and the usage of personal protective equipment.**

**The manufacturer will not be held liable for injury or property damage from negligence, improper training, machine modifications or misuse.**

# **WARNING!**

**Some dust created by power sanding, sawing, grinding, drilling, and other construction activities contains chemicals known to the State of California to cause cancer, birth defects or other reproductive harm. Some examples of these chemicals are:**

- **Lead from lead-based paints.**
- **Crystalline silica from bricks, cement and other masonry products.**
- **Arsenic and chromium from chemically-treated lumber.**

**Your risk from these exposures varies, depending on how often you do this type of work. To reduce your exposure to these chemicals: Work in a well ventilated area, and work with approved safety equipment, such as those dust masks that are specially designed to filter out microscopic particles.**

# Table of Contents

<b>INTRODUCTION.....</b>	<b>2</b>	<b>SECTION 5: ACCESSORIES.....</b>	<b>28</b>
Manual Accuracy .....	2	<b>SECTION 6: MAINTENANCE.....</b>	<b>30</b>
Contact Info.....	2	Schedule .....	30
Machine Description .....	2	Cleaning.....	30
Identification.....	3	Lathe Bed.....	30
Machine Data Sheet .....	4	Tailstock.....	30
<b>SECTION 1: SAFETY.....</b>	<b>6</b>	Lubrication .....	30
Safety Instructions for Machinery .....	6	<b>SECTION 7: SERVICE .....</b>	<b>31</b>
Additional Safety for Wood Lathes .....	8	Troubleshooting .....	31
<b>SECTION 2: CIRCUIT REQUIREMENTS .....</b>	<b>9</b>	Aligning Centers.....	33
110V Operation.....	9	Replacing V-Belt .....	33
<b>SECTION 3: SETUP .....</b>	<b>10</b>	<b>SECTION 8: WIRING &amp; ELECTRICAL .....</b>	<b>34</b>
Needed for Setup.....	10	Wiring Safety Instructions .....	34
Unpacking .....	10	Electrical Components & Wiring Diagram ...	35
Inventory .....	11	<b>SECTION 9: PARTS .....</b>	<b>36</b>
Cleanup.....	12	Main .....	36
Site Considerations.....	13	Machine Labels.....	38
Mounting .....	14	<b>WARRANTY AND RETURNS .....</b>	<b>41</b>
Assembly .....	15		
Power Connection.....	16		
Test Run .....	16		
<b>SECTION 4: OPERATIONS .....</b>	<b>18</b>		
Adjusting Head.....	18		
Adjusting Tailstock Position .....	19		
Adjusting Tool Rest.....	20		
Installing/Removing Spur Center .....	20		
Installing/Removing Live Center .....	21		
Installing/Removing Faceplate.....	22		
Selecting Turning Tools .....	23		
Spindle Turning.....	24		
Faceplate Turning.....	26		
Outboard Turning.....	27		
Sanding/Finishing Using the Lathe .....	27		

# INTRODUCTION

## Manual Accuracy

We are proud to offer this manual with your new machine! We've made every effort to be exact with the instructions, specifications, drawings, and photographs of the machine we used when writing this manual. However, sometimes we still make an occasional mistake.

Also, owing to our policy of continuous improvement, **your machine may not exactly match the manual**. If you find this to be the case, and the difference between the manual and machine leaves you in doubt, check our website for the latest manual update or call technical support for help.

Before calling, find the manufacture date of your machine by looking at the date stamped into the machine ID label (see below). This will help us determine if the manual version you received matches the manufacture date of your machine.

		MODEL GXXXX MACHINE NAME
SPECIFICATIONS		▲ WARNING!
Motor: Specification: Specification: Specification: Weight:	<b>Manufacture Date of Your Machine</b>	ing this machine: operation. s and respirator. sted/setup and suit before starting.
<input type="text"/> Date <input type="text"/> Serial Number	4. make sure the motor has stopped and disconnect power before adjustments, maintenance, or service. 5. DO NOT expose to rain or dampness. 6. DO NOT modify this machine in any way. 7. DO NOT remove safety guards. 8. Never leave machine running unattended. 9. DO NOT operate under the influence of drugs or alcohol. 10. Maintain machine carefully to prevent accidents.	
Manufactured for Grizzly in Taiwan		

For your convenience, we post all available manuals and manual updates for free on our website at [www.grizzly.com](http://www.grizzly.com). Any updates to your model of machine will be reflected in these documents as soon as they are complete.

## Contact Info

We stand behind our machines. If you have any service questions, parts requests or general questions about the machine, please call or write us at the location listed below.

Grizzly Industrial, Inc.  
1203 Lycoming Mall Circle  
Muncy, PA 17756  
Phone: (570) 546-9663  
E-Mail: [techsupport@grizzly.com](mailto:techsupport@grizzly.com)

We want your feedback on this manual. If you can take the time, please email or write to us at the address below and tell us how we did:

Grizzly Industrial, Inc.  
c/o Technical Documentation Manager  
P.O. Box 2069  
Bellingham, WA 98227-2069  
Email: [manuals@grizzly.com](mailto:manuals@grizzly.com)

## Machine Description

The Model G0462 Wood Lathe is designed to turn wood stock so the operator can remove material with a hand-held cutting tool or chisel.

The variable speed allows for infinite spindle speed adjustment from 600–2400 RPM, and the digital readout provides a precise reading of the current spindle speed.

The ability to rotate and move the head allows for turning workpieces with diameters larger than 10" on the outboard side of the lathe.

The heavy-duty tailstock provides substantial stability when mounting the workpiece between centers.



# Identification

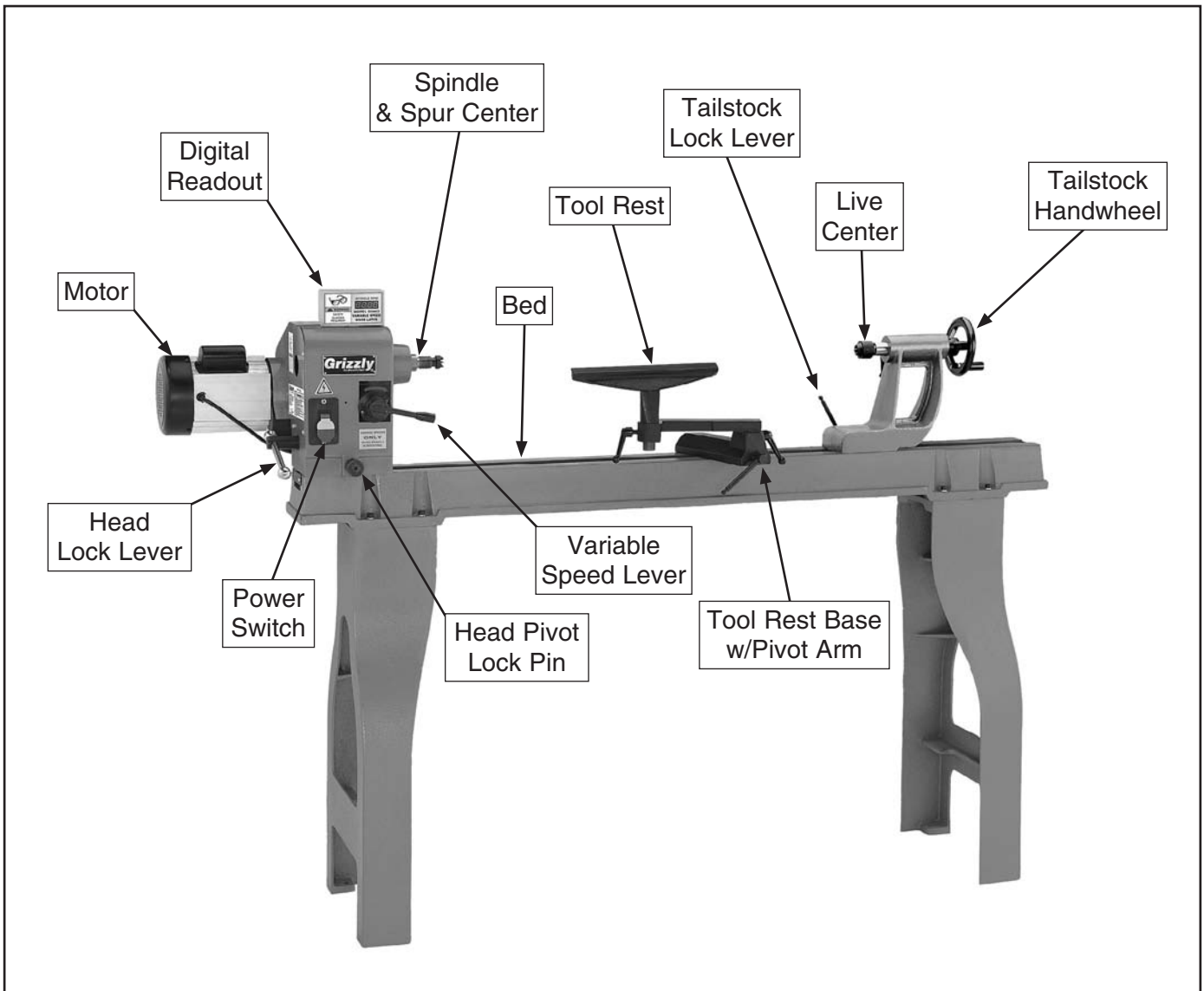

Figure 1. Model G0462 identification.





# MACHINE DATA SHEET

Customer Service #: (570) 546-9663 · To Order Call: (800) 523-4777 · Fax #: (800) 438-5901

## MODEL G0462 WOOD LATHE WITH DIGITAL READOUT

### Product Dimensions:

Weight..... 287 lbs.  
 Length/Width/Height..... 72-1/2 x 19 x 48 in.  
 Foot Print (Length/Width)..... 54 x 13-3/4 in.

### Shipping Dimensions:

Type..... Cardboard  
 Content..... Machine  
 Weight..... 294 lbs.  
 Length/Width/Height..... 63-1/2 x 17-1/2 x 20-1/2 in.

### Electrical:

Switch..... Paddle with Lockout Key  
 Switch Voltage..... 110V  
 Cord Length..... 8 ft.  
 Cord Gauge..... 16 gauge  
 Minimum Circuit Size..... 20 amp  
 Plug Included..... Yes

### Motors:

#### Main

Type..... TEFC Capacitor Start Induction  
 Horsepower..... 2 HP  
 Voltage..... 110V  
 Prewired..... 110V  
 Phase..... Single  
 Amps..... 14A  
 Speed..... 1725 RPM  
 Cycle..... 60 Hz  
 Number Of Speeds..... 1  
 Power Transfer ..... V-Belt Drive  
 Bearings..... Shielded and Lubricated

### Main Specifications:

#### Operation Information

Swing Over Bed..... 16 in.  
 Dist Between Centers..... 46 in.  
 Swing Over Tool Rest..... 13 in.  
 No Of Spindle Speeds..... Variable  
 Spindle Speeds..... 600 - 2400 RPM  
 Floor To Center Height..... 43 in.  
 Headstock Rotation..... 0, 60, 90, 120, 180 deg.



**Spindle Information**

Spindle Type..... Right Hand  
Spindle Taper..... MT#2  
Spindle Size..... 1 in.  
Spindle Bore..... 3/8 in.  
Spindle Center..... Spur  
Spindle TPI..... 8

**Tailstock Information**

Tailstock Taper..... MT#2  
Tailstock Center..... Live

**Construction**

Bed Construction..... Precision Ground Cast Iron  
Frame Construction..... Cast Iron  
Stand Construction..... Cast Iron  
Base Construction..... Cast Iron  
Headstock Construction..... Cast Iron  
Tailstock Construction..... Cast Iron  
Paint..... Powder Coated

**Other Related Information**

Mobile Base..... G7315Z, G8685Z

**Other Specifications:**

Country Of Origin ..... China  
Warranty ..... 1 Year  
Serial Number Location ..... Grizzly ID Label  
Assembly Time ..... 1 hour

**Features:**

Heavy Duty, Precision Ground Cast Iron Bed and Cast Iron Legs Ensures Stability and Minimal Vibration  
Quick Lock/Release Levers for Tailstock and Headstock  
Outboard Turning is Easy with Standard Tool Rest Extension  
Spindle Tachometer with Digital Readout



# SECTION 1: SAFETY

## WARNING

### For Your Own Safety, Read Instruction Manual Before Operating this Machine

The purpose of safety symbols is to attract your attention to possible hazardous conditions. This manual uses a series of symbols and signal words intended to convey the level of importance of the safety messages. The progression of symbols is described below. Remember that safety messages by themselves do not eliminate danger and are not a substitute for proper accident prevention measures.



Indicates an imminently hazardous situation which, if not avoided, **WILL** result in death or serious injury.



Indicates a potentially hazardous situation which, if not avoided, **COULD** result in death or serious injury.



Indicates a potentially hazardous situation which, if not avoided, **MAY** result in minor or moderate injury. It may also be used to alert against unsafe practices.

**NOTICE**

This symbol is used to alert the user to useful information about proper operation of the machine.

## WARNING

### Safety Instructions for Machinery

**OWNER'S MANUAL.** Read and understand this owner's manual **BEFORE** using machine. Untrained users can be seriously hurt.

**EYE PROTECTION.** Always wear ANSI-approved safety glasses or a face shield when operating or observing machinery. to reduce the risk of eye injury or blindness from flying particles Everyday eyeglasses are not approved safety glasses.

**HAZARDOUS DUST.** Dust created while using machinery may cause cancer, birth defects, or long-term respiratory damage. Be aware of dust hazards associated with each workpiece material, and always wear a NIOSH-approved respirator to reduce your risk.

**WEARING PROPER APPAREL.** Do not wear clothing, apparel, or jewelry that can become entangled in moving parts. Always tie back or cover long hair. Wear non-slip footwear to avoid accidental slips which could cause a loss of work-piece control.

**HEARING PROTECTION.** Always wear hearing protection when operating or observing loud machinery. Extended exposure to this noise without hearing protection can cause permanent hearing loss.

**MENTAL ALERTNESS.** Be mentally alert when running machinery. Never operate under the influence of drugs or alcohol, when tired, or when distracted.





# WARNING

## Safety Instructions for Machinery

**DISCONNECTING POWER SUPPLY.** Always disconnect machine from power supply before servicing, adjusting, or changing cutting tools (bits, blades, cutters, etc.). Make sure switch is in OFF position before reconnecting to avoid an unexpected or unintentional start.

**INTENDED USE.** Only use the machine for its intended purpose and only use recommended accessories. Never stand on machine, modify it for an alternative use, or outfit it with non-approved accessories.

**STABLE MACHINE.** Unexpected movement during operations greatly increases the risk of injury and loss of control. Verify machines are stable/secure and mobile bases (if used) are locked before starting.

**FORCING MACHINERY.** Do not force machine. It will do the job safer and better at the rate for which it was designed.

**GUARDS & COVERS.** Guards and covers can protect you from accidental contact with moving parts or flying debris. Make sure they are properly installed, undamaged, and working correctly before using machine.

**REMOVING TOOLS.** Never leave adjustment tools, chuck keys, wrenches, etc. in or on machine—especially near moving parts. Verify removal before starting!

**AWKWARD POSITIONS.** Keep proper footing and balance at all times when operating machine. Do not overreach! Avoid awkward hand positions that make workpiece control difficult or increase the risk of accidental injury.

**DANGEROUS ENVIRONMENTS.** Do not use machinery in wet locations, cluttered areas, around flammables, or in poorly-lit areas. Keep work area clean, dry, and well lighted to minimize risk of injury.

**APPROVED OPERATION.** Untrained operators can be seriously hurt by machinery. Only allow trained or properly supervised people to use machine. When machine is not being used, disconnect power, remove switch keys, or lock-out machine to prevent unauthorized use—especially around children. Make workshop kid proof!

**CHILDREN & BYSTANDERS.** Keep children and bystanders a safe distance away from work area. Stop using machine if children or bystanders become a distraction.

**FEED DIRECTION.** Unless otherwise noted, feed work against the rotation of blades or cutters. Feeding in the same direction of rotation may pull your hand into the cut.

**SECURING WORKPIECE.** When required, use clamps or vises to secure workpiece. A secured workpiece protects hands and frees both of them to operate the machine.

**UNATTENDED OPERATION.** Never leave machine running while unattended. Turn machine **OFF** and ensure all moving parts completely stop before walking away.

**MAINTENANCE & INSPECTION.** A machine that is not properly maintained may operate unpredictably. Follow all maintenance instructions and lubrication schedules to keep machine in good working condition. Regularly inspect machine for loose bolts, alignment of critical parts, binding, or any other conditions that may affect safe operation. Always repair or replace damaged or mis-adjusted parts before operating machine.

**EXPERIENCING DIFFICULTIES.** If at any time you are experiencing difficulties performing the intended operation, stop using the machine! Contact our Technical Support Department at (570) 546-9663.



## **WARNING**

# Additional Safety for Wood Lathes

- 1. KEEPING GUARDS IN PLACE.** To prevent entanglement hazards, make sure all doors and guards are secured in place and that the lathe sits on a flat, stable surface.
- 2. EYE/FACE PROTECTION.** Airborne wood dust and debris can be hazardous to the eyes/face and may cause allergies or long-term respiratory health problems. Always wear eye protection or a face shield and a respirator when operating the lathe.
- 3. USING CENTERS.** When using centers, be certain the workpiece has been properly embedded on them and that there is adequate clearance for the full rotation.
- 4. ADJUSTING TOOL REST.** To prevent the turning tool and your hands being pulled into the spinning workpiece, always adjust the tool rest to provide proper support for the turning tool you will be using. Test the tool rest clearance by rotating workpiece by hand before connecting the lathe to power.
- 5. TURNING SPEED.** Select the correct turning speed for your work, and allow the lathe to gain full speed before using.
- 6. USING SHARP CHISELS.** Keep lathe chisels properly sharpened and held firmly on the tool rest when turning.
- 7. OPERATING DAMAGED LATHE.** Never operate the lathe with damaged or worn parts that fly apart during operation.
- 8. WORKPIECE CONDITION.** To prevent the workpiece breaking apart and flying at the operator, always inspect the condition of the workpiece. DO NOT turn pieces with knots, splits, and other potentially dangerous conditions. Make sure joints of glued-up pieces have high quality bonds and will not fly apart during operation.
- 9. STOPPING LATHE.** DO NOT stop the lathe by using your hand against the workpiece which could cause serious injury. Allow the lathe to stop on its own.
- 10. SANDING/POLISHING.** To maintain an adequate and safe working area, always remove the tool rest when performing sanding or polishing operations on the rotating workpiece.
- 11. MATERIAL REMOVAL RATE.** Attempting to remove too much material at once may cause the workpiece to fly out of the lathe.
- 12. PREVENTING THROWN WORKPIECE.** Make sure that lathe is in its lowest speed when starting up. An out-of-balance workpiece or high RPM start can eject the workpiece.
- 13. FACEPLATE TURNING.** When faceplate turning, make sure the faceplate is securely attached to the workpiece and it is properly attached to the spindle. Always use lathe chisels on the downward spinning side of the workpiece only.

## **WARNING**

Like all machinery there is potential danger when operating this lathe. Accidents are frequently caused by lack of familiarity or failure to pay attention. Use this lathe with respect and caution to reduce the risk of operator injury. If normal safety precautions are overlooked or ignored, serious personal injury may occur.



# SECTION 2: CIRCUIT REQUIREMENTS

## 110V Operation

### **!WARNING**

Serious personal injury could occur if you connect the machine to power before completing the setup process. **DO NOT** connect the machine to the power until instructed later in this manual.



### **!WARNING**

Electrocution or fire could result if machine is not grounded and installed in compliance with electrical codes. Compliance **MUST** be verified by a qualified electrician!

### Full Load Amperage Draw

This machine draws the following amps under maximum load:

Amp Draw..... 14 Amps

### Power Supply Circuit Requirements

The power supply circuit for your machine **MUST** be grounded and rated for the amperage given below. Never replace a circuit breaker on an existing circuit with one of higher amperage without consulting a qualified electrician to ensure compliance with wiring codes. **If you are unsure about the wiring codes in your area or you plan to connect your machine to a shared circuit, consult a qualified electrician.**

Minimum Circuit Size.....20 Amps

### Power Connection Device

The Model G0462 comes prewired with a NEMA 5-15 plug, as shown in **Figure 2**.

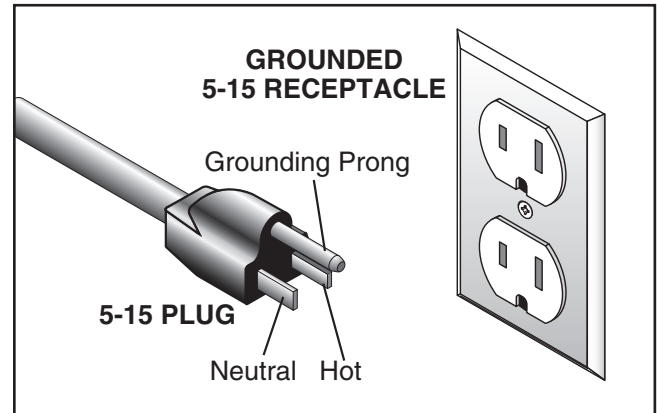

**Figure 2.** NEMA 5-15 plug and receptacle.

### Extension Cords

Using extension cords may reduce the life of the motor. Instead, place the machine near a power source. If you must use an extension cord:

- Use at least a 14 gauge cord that does not exceed 50 feet in length!
- The extension cord must also have a ground wire and plug pin.
- A qualified electrician **MUST** size cords over 50 feet long to prevent motor damage.



# SECTION 3: SETUP

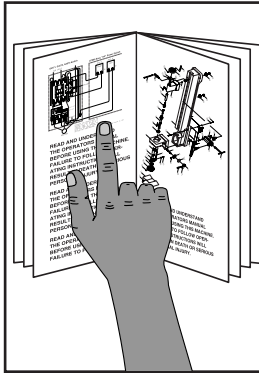

## **!WARNING**

This machine presents serious injury hazards to untrained users. Read through this entire manual to become familiar with the controls and operations before starting the machine!

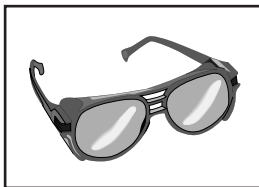

## **!WARNING**

Wear safety glasses during the entire setup process!

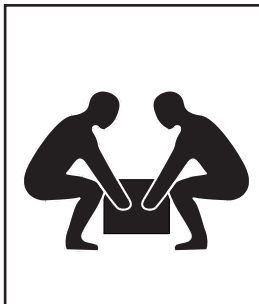

## **!WARNING**

This machine and its components are very heavy. Get lifting help or use power lifting equipment such as a forklift to move heavy items.

## Needed for Setup

The following are needed to complete the setup process, but are not included with your machine.

Description	Qty
• Additional People .....	At Least 2
• Safety Glasses .....	1 For Each Person
• Cleaner/Degreaser ( <b>Page 12</b> ) ....	As Needed
• Disposable Shop Rags.....	As Needed
• Mounting Hardware ( <b>Page 14</b> ) ...	As Needed
• Precision Level .....	1
• Measuring Tape.....	1

## Unpacking

Your machine was carefully packaged for safe transportation. Remove the packaging materials from around your machine and inspect it. If you discover the machine is damaged, *please immediately call Customer Service at (570) 546-9663 for advice.*

Save the containers and all packing materials for possible inspection by the carrier or its agent. *Otherwise, filing a freight claim can be difficult.*

When you are completely satisfied with the condition of your shipment, inventory the contents.



# Inventory

The following is a list of the small components shipped with your machine. Lay the components out to inventory them.

**Note:** *If you can't find an item on this list, check the mounting location on the machine or examine the packaging materials carefully. Occasionally we pre-install certain components for shipping purposes.*

<b>Box 1 Inventory (Figure 3)</b>	<b>Qty</b>
A. Lathe Unit.....	1
B. Faceplate 6".....	1
C. Hardware Bag.....	1
D. Knockout Tool.....	1
E. Flat Wrenches 32mm.....	2

<b>Hardware Bag Inventory (Figure 4)</b>	<b>Qty</b>
F. Spur Center.....	1
G. Live Center.....	1
H. Tool Rest Lock Lever.....	1
I. Hex Wrenches 3, 4, 6mm.....	1 Each
J. Cap Screws M8-1.25 x 35.....	8
K. Quill Lock Lever.....	1
L. Lock Washers 8mm.....	8

<b>Box 2 Inventory (Figure 5)</b>	<b>Qty</b>
M. Stand Legs.....	2

If any nonproprietary parts are missing (e.g. a nut or a washer), we will gladly replace them; or for the sake of expediency, replacements can be obtained at your local hardware store.

	<p><b>⚠ WARNING</b>  <b>SUFFOCATION HAZARD!</b>          Immediately discard all plastic bags and packing materials to eliminate choking/suffocation hazards for children and animals.</p>
---	--

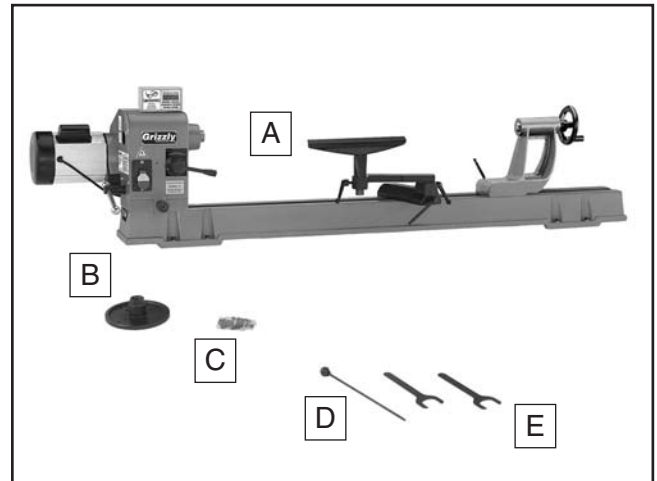

Figure 3. Box 1 inventory.



Figure 4. Hardware bag inventory.

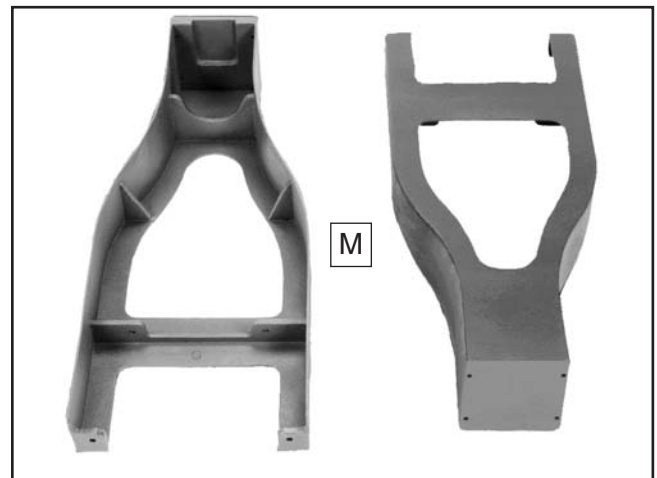

Figure 5. Box 2 inventory.

# Cleanup

The unpainted surfaces of your machine are coated with a heavy-duty rust preventative that prevents corrosion during shipment and storage.

This rust preventative has been your machine's close ally and guardian since it left the factory. If your machine arrived to you free of rust, then be thankful that the rust preventative protected it during its journey...and try to stay thankful as you clean it off, because it can be challenging to remove if you are unprepared and impatient.

Plan on spending some time cleaning your machine. The time you spend doing this will reward you with smooth sliding parts and a better appreciation for the proper care of your machine's unpainted surfaces.

Although there are many ways to successfully remove the rust preventative, these instructions walk you through what works well for us.

## Before cleaning, gather the following:

- Disposable Rags
- Cleaner/degreaser (see below)
- Safety glasses & disposable gloves

## H9692—Orange Power Cleaner & Degreaser

One of the best cleaners we've found for quickly and easily removing rust preventative.



**Figure 6.** Model H9692 Industrial Orange Power Cleaner/Degreaser (99.9% biodegradable).

**Note:** *In a pinch, automotive degreasers, mineral spirits or WD•40 can be used to remove rust preventative. Before using these products, though, test them on an inconspicuous area of your paint to make sure they will not damage it.*

	<b>WARNING</b> Gasoline and petroleum products have low flash points and can explode or cause fire if used to clean machinery. Avoid using these products to clean machinery.
--	--

	<b>CAUTION</b> Many cleaning solvents are toxic if inhaled. Minimize your risk by only using these products in a well ventilated area.
--	---

<b>NOTICE</b> Avoid chlorine-based solvents, such as acetone or brake parts cleaner that may damage painted surfaces. Always follow the manufacturer's instructions when using any type of cleaning product.
---

## Basic steps for removing rust preventative:

1. Put on safety glasses and disposable gloves.
2. Coat all surfaces that have rust preventative with a liberal amount of your cleaner/degreaser and let them soak for few minutes.
3. Wipe off the surfaces. If your cleaner/degreaser is effective, the rust preventative will wipe off easily.

**Note:** *To clean off thick coats of rust preventative on flat surfaces, such as tables, use a PLASTIC paint scraper to scrape off the majority of the coating before wiping it off with your rag. (Do not use a metal scraper or you may scratch your machine.)*

4. Repeat **Steps 2–3** as necessary until clean, then coat all unpainted surfaces with a quality metal protectant to prevent rust.



# Site Considerations

## Weight Load

Refer to the **Machine Data Sheet** for the weight of your machine. Make sure that the surface upon which the machine is placed will bear the weight of the machine, additional equipment that may be installed on the machine, and the heaviest workpiece that will be used. Additionally, consider the weight of the operator and any dynamic loading that may occur when operating the machine.

## Space Allocation

Consider the largest size of workpiece that will be processed through this machine and provide enough space around the machine for adequate operator material handling or the installation of auxiliary equipment. With permanent installations, leave enough space around the machine to open or remove doors/covers as required by the maintenance and service described in this manual. **See below for required space allocation.**

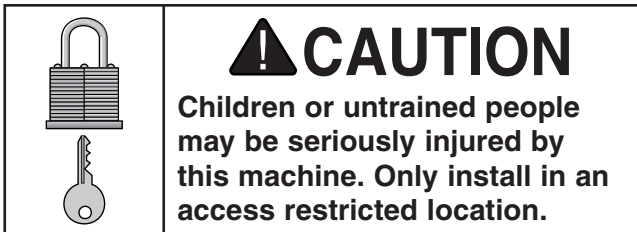

## Physical Environment

The physical environment where your machine is operated is important for safe operation and the longevity of its components. For best results, operate this machine in a dry environment that is free from excessive moisture, hazardous chemicals, airborne abrasives, or extreme conditions. Extreme conditions for this type of machinery are generally those where the ambient temperature range exceeds 41°–104°F; the relative humidity range exceeds 20–95% (non-condensing); or the environment is subject to vibration, shocks, or bumps.

## Electrical Installation

Place this machine near an existing power source. Make sure all power cords are protected from traffic, material handling, moisture, chemicals, or other hazards. Make sure to leave access to a means of disconnecting the power source or engaging a lockout/tagout device.

## Lighting

Lighting around the machine must be adequate enough that operations can be performed safely. Shadows, glare, or strobe effects that may distract or impede the operator must be eliminated.

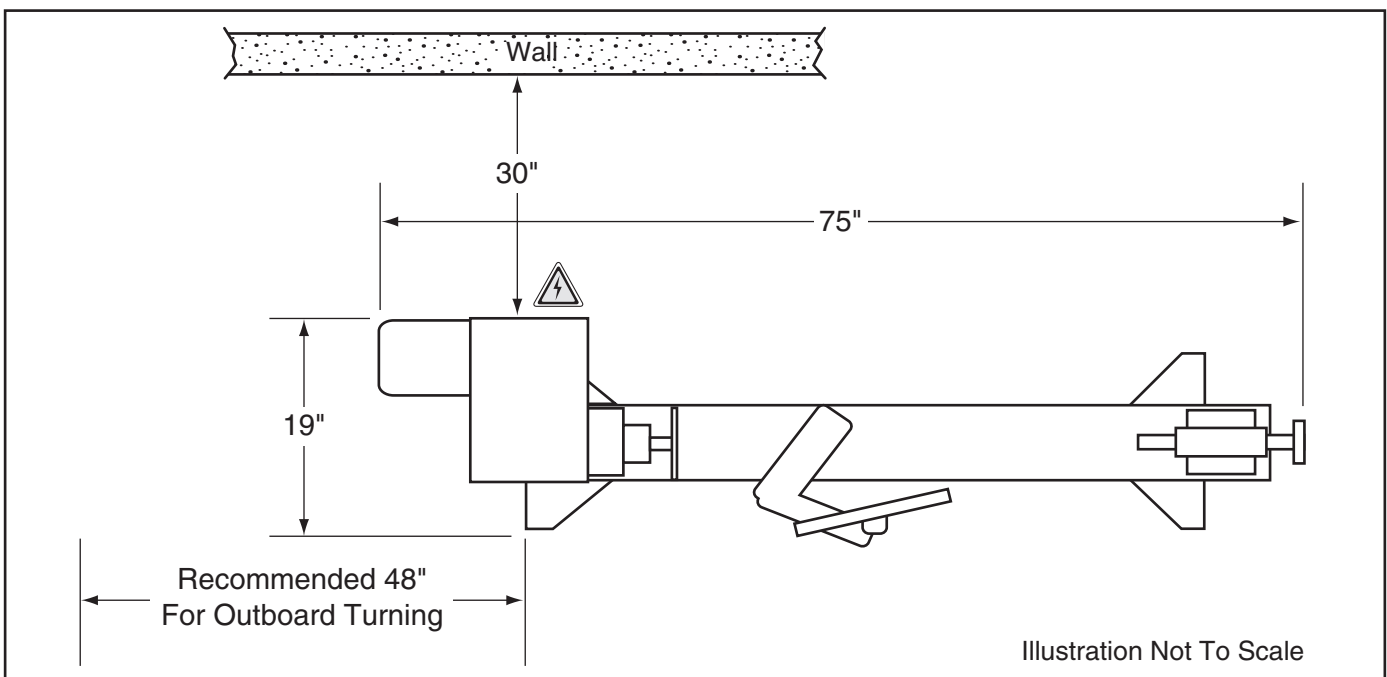

**Figure 7.** Minimum working clearances.



# Mounting

Although not required, we recommend that you mount your new machine to the floor. Because this is an optional step and floor materials may vary, floor mounting hardware is not included. Generally, you can either bolt your machine to the floor or mount it on machine mounts. Both options are described below. Whichever option you choose, it is necessary to level your machine with a precision level.

## Bolting to Concrete Floors

Anchor studs and lag shield anchors with lag screws (Figure 8) are two popular methods for anchoring an object to a concrete floor. We suggest you research the many options and methods for mounting your machine and choose the best that fits your specific application.

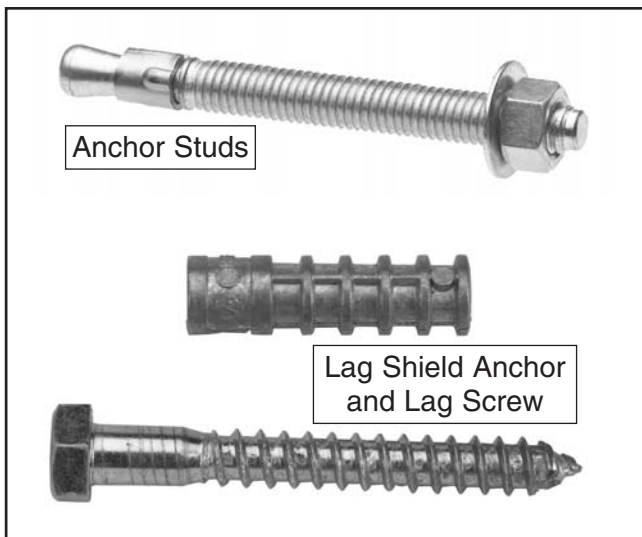

Figure 8. Typical fasteners for mounting to concrete floors.

## NOTICE

Anchor studs are stronger and more permanent alternatives to lag shield anchors; however, they will stick out of the floor, which may cause a tripping hazard if you decide to move your machine.

## Using Machine Mounts

Using machine mounts, shown in Figure 9, gives the advantage of fast leveling and vibration reduction. The large size of the foot pads distributes the weight of the machine to reduce strain on the floor.



Figure 9. Machine mount example.

## NOTICE

We strongly recommend securing your machine to the floor if it is hardwired to the power source. Consult with your electrician to ensure compliance with local codes.



# Assembly

## To mount the lathe to the stand:

1. Stand the legs up approximately 41" apart, then get them reasonably aligned, as shown in **Figure 10**.

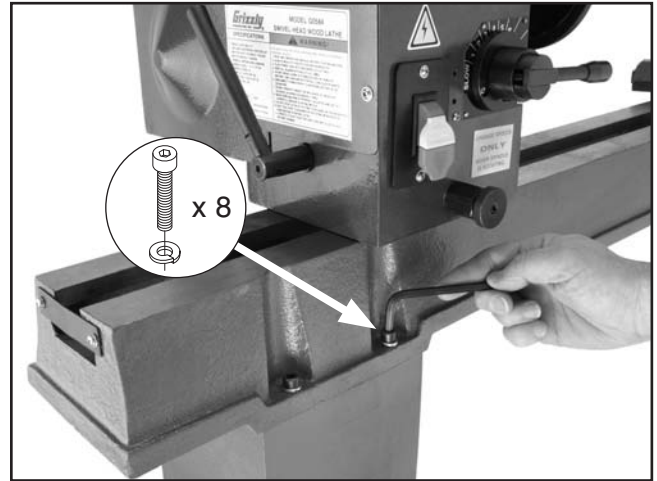

**Figure 10.** Stand legs approximately 41" apart to prepare for mounting the lathe.

2. Use the help of additional people to carefully lift the lathe onto the legs and align the mounting holes.

**Note:** *The headstock end is the heaviest and usually requires two people lifting at that end.*

3. Secure the lathe to the legs with the (8) M8-1.25 x 35 cap screws and 8mm lock washers, as shown in **Figure 11**.



**Figure 11.** Securing lathe to the stand leg.

4. Install the tool rest lock lever to secure the tool rest, as shown in **Figure 12**.

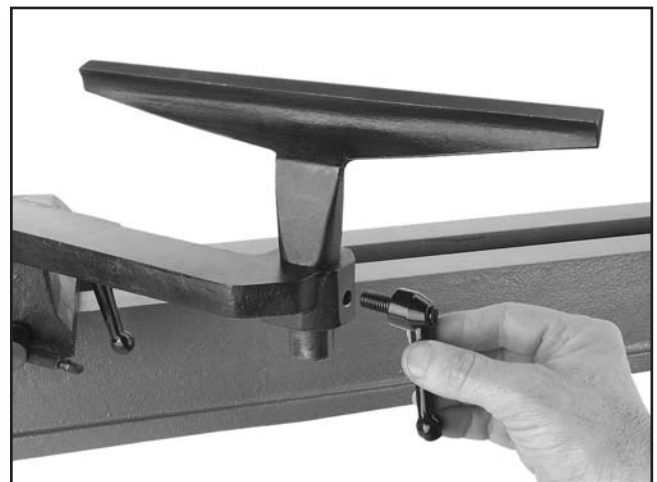

**Figure 12.** Installing handle into tool rest.

5. Align the quill keyway with the entry hole of the quill lock lever (see **Figure 13**), then install the lever into the tailstock so that the end of it mates with the quill keyway.

**Note:** Make sure the dog-point end of the lock lever fits into the quill keyway so that the quill can move in and out of the tailstock without rotating.

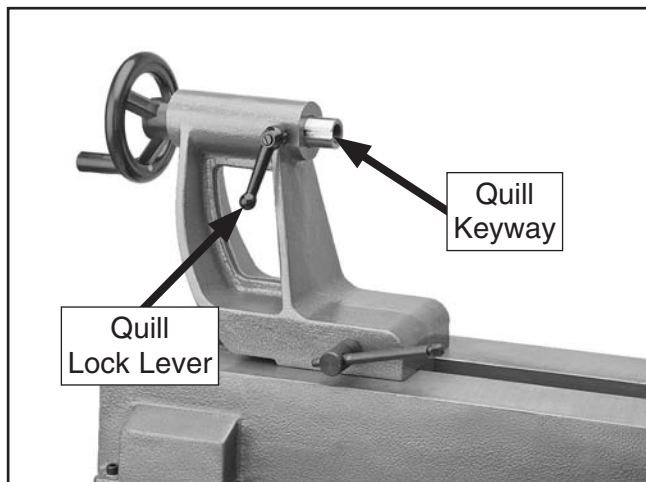

**Figure 13.** Quill lock lever.

6. Attach the digital readout to the top of the head with the pre-installed Phillips head screws, lock washers, and flat washers, as shown in **Figure 14**.

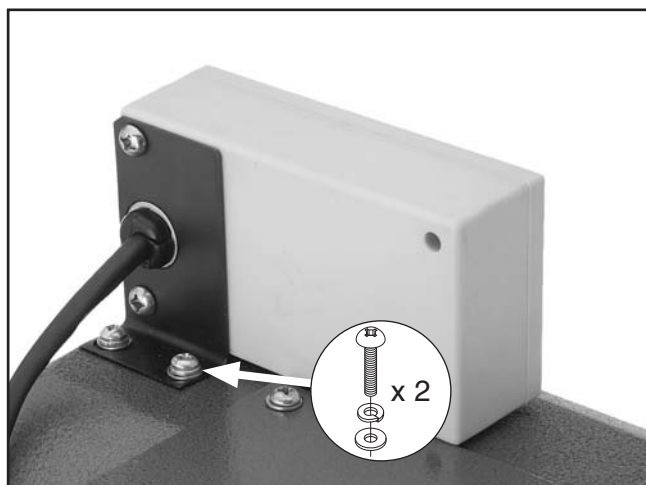

**Figure 14.** Digital readout installed.

## Power Connection

Before the machine can be connected to the power source, an electrical circuit must be made available that meets the minimum specifications given in the **Circuit Requirements** on **Page 9**. If a power circuit has not been prepared for the machine, do that now. To ensure a safe and code-compliant setup, we strongly recommend that all electrical work be done by a qualified electrician.

## Test Run

Once the assembly is complete, test run your machine to make sure it runs properly.

If, during the test run, you cannot easily locate the source of an unusual noise or vibration, stop using the machine immediately, then review the **Troubleshooting** on **Page 31**.

If you still cannot remedy a problem, contact our Tech Support at (570) 546-9663 for assistance.

### To test run the machine:

1. Make sure you have read the safety instructions at the beginning of the manual and that the machine is set up properly.
2. Make sure all tools and objects used during setup are cleared away from the machine.
3. Plug the lathe into the power source.
4. Flip the paddle up to turn the lathe **ON**.

**Note:** Make sure that your hand stays poised over the switch in case you need to quickly turn the machine **OFF**.

5. Listen to and watch for abnormal noises or actions. The lathe should run smoothly with little or no vibration or rubbing noises.

—Strange or unnatural noises should be investigated and corrected before operating the machine further. Always unplug the machine when investigating or correcting any situation with the machine.

6. Turn the lathe **OFF**, then remove the yellow switch disabling key from the paddle switch, as shown in **Figure 15**.

7. Try to start the machine with the paddle switch.

—If the machine does not start, the switch disabling feature is working as designed.

—If the machine starts, immediately stop the machine. The switch disabling feature is not working correctly. This safety feature must work properly before proceeding with regular operations. Call our Tech Support at (570) 546-9663 for help

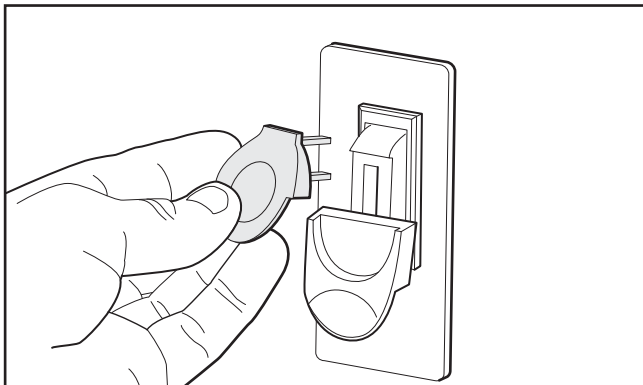

**Figure 15.** Removing switch disabling key from the paddle switch.

## NOTICE

The spindle speed levers adjust the pulley width to change the spindle speed. To prevent damage to this mechanism, the lathe **MUST** be running before using the variable speed lever.

8. Turn the lathe **ON**.

9. Test the variable speed by pulling out the speed lever (**Figure 16**) and slowly turning the speed up, then down.



**Figure 16.** Variable speed lever.

—The machine should speed up and slow down as you move the lever. If this is the case, then the test run is over and your machine is ready for normal operations.

—If the lathe has problems changing speeds, turn the lathe **OFF**, disconnect it from power, and refer to the troubleshooting chart on **Page 31**, or call our Tech Support at (570) 546-9663 for additional help.

# SECTION 4: OPERATIONS

## ⚠️ WARNING

Damage to your eyes and lungs could result from using this machine without proper protective gear. Always wear safety glasses and a respirator when operating this machine.



## ⚠️ WARNING

Loose hair and clothing could get caught in machinery and cause serious personal injury. Keep loose clothing and long hair away from moving machinery.

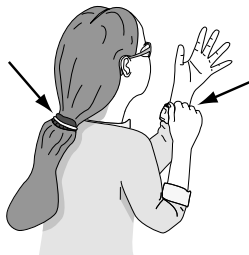

## NOTICE

If you have never used this type of machine or equipment before, WE STRONGLY RECOMMEND that you read books, trade magazines, or get formal training before beginning any projects. Regardless of the content in this section, Grizzly Industrial will not be held liable for accidents caused by lack of training.

## Adjusting Head

The Model G0462 headstock can be positioned anywhere along the bed and pivoted up to 180°.

To position the headstock along the length of the bed:

1. DISCONNECT LATHE FROM POWER!
2. Loosen the head lock lever shown in Figure 17.



Figure 17. Head lock lever.

3. Slide the headstock to the desired position, then re-tighten the lock lever.

**Note:** The large hex nut under the headstock may require occasional adjustment to ensure proper clamping pressure to the bed. Turn the hex nut in small increments to fine tune the clamping pressure, as needed.

## ⚠️ CAUTION

If the lathe head unexpectedly moves during operation, the tool and your hand could be drawn into the spinning workpiece resulting in personal injury. ALWAYS make sure the head lock lever is tight and the head pivot pin is seated before operation.



## To pivot the headstock:

1. DISCONNECT LATHE FROM POWER!
2. Make sure the head lock lever is tight.
3. Pull the pivot lock pin out (see **Figure 18**) and pivot the headstock clockwise  $90^\circ$  or  $180^\circ$ , as shown in **Figure 19**.

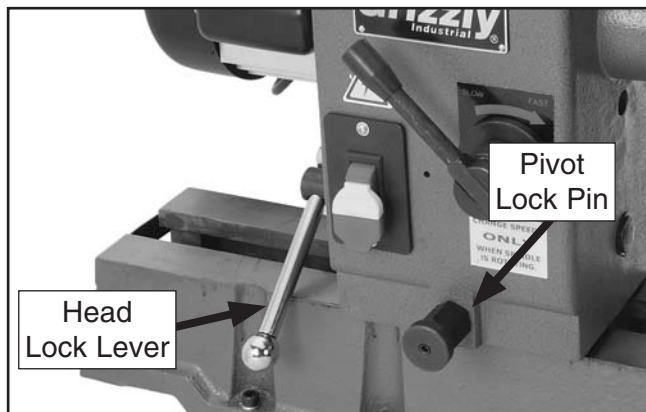

**Figure 18.** Pivot lock pin location.



**Figure 19.** Head set at  $90^\circ$  and  $180^\circ$ .

4. Release the pivot lock pin. Make sure the pin has engaged in its detent by trying to rotate the headstock.

## Adjusting Tailstock Position

The tailstock is equipped with a cam-action clamping system to secure it. When the lock lever is tightened, a locking plate lifts up and secures the tool rest to the bed.

To re-position the tailstock along the bed, loosen the tailstock lock lever (see **Figure 20**), move the tailstock to the desired position, then re-tighten the lock lever.

**Note:** *If the lock lever will not securely clamp the tailstock down onto the bed (either too loose or too tight), loosen or tighten the hex nut located on the underside of the tailstock in small increments to achieve the proper clamping pressure.*

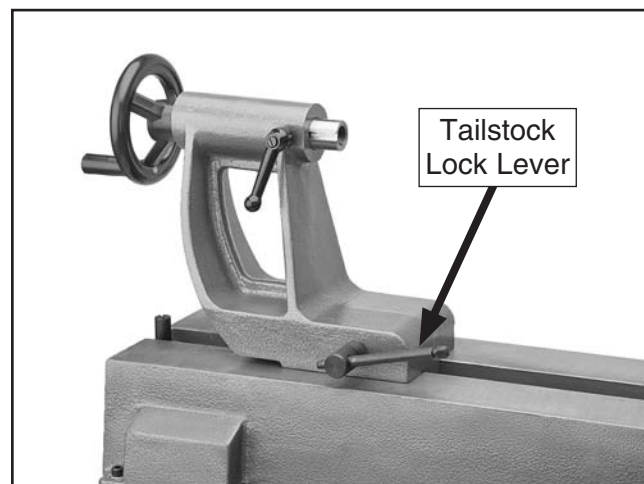

**Figure 20.** Tailstock lock lever.

# Adjusting Tool Rest

The tool rest is equipped with a cam-action clamping system to secure it. When the base lock lever is tightened, a clamping plate lifts up and secures the tool rest to the bed.

## ⚠ CAUTION

If the tool rest unexpectedly moves during operation, the tool and your hand could be drawn into the spinning workpiece resulting in personal injury. ALWAYS make sure all of the tool rest locks are tight before beginning operation.

The Model G0462 comes with a three-way adjustable tool rest (see **Figure 21**).

- Use the base lock lever to secure the tool rest along the length of the bed.
- Use the pivot arm lock lever to secure the tool rest at a working distance from the workpiece.
- Use the tool rest lock lever to adjust the height and angle of the tool rest relative to the workpiece.

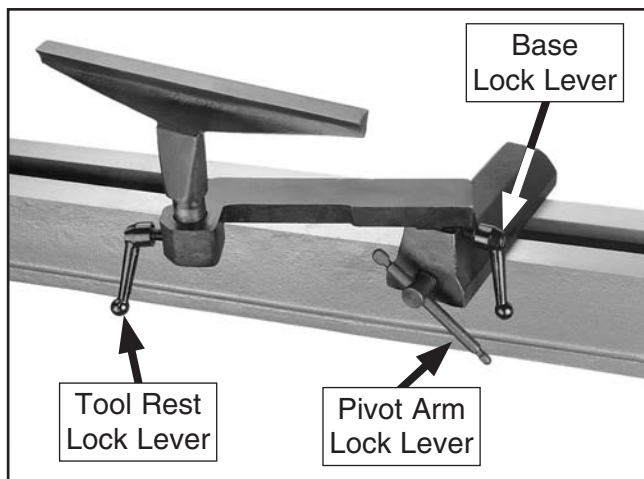

**Figure 21.** Tool rest controls.

For safe and good turning results, we recommend positioning the tool rest approximately  $\frac{1}{4}$ " away from the workpiece, and approximately  $\frac{1}{8}$ " above the workpiece center line (see **Figure 22**).

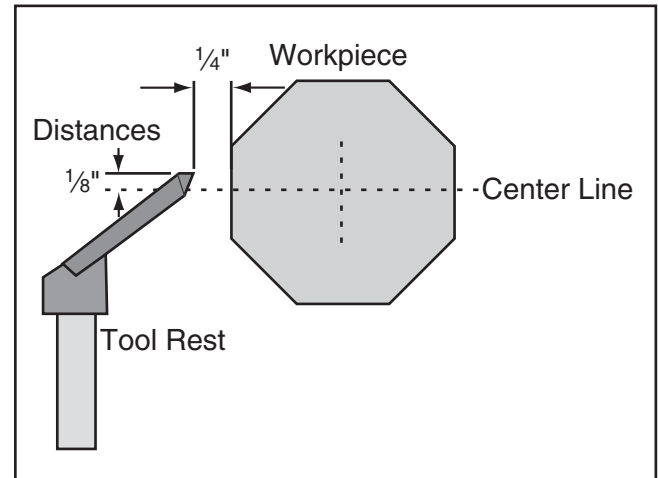

**Figure 22.** Tool rest position relative to the workpiece.

# Installing/Removing Spur Center

The included MT#2 spur center installs in the spindle and forces the workpiece to spin with the spindle.

Typically, the spur center is driven into the workpiece (see **Spindle Turning** on **Page 24** for detailed instructions), then the center is inserted with the workpiece into the spindle.

## To install the spur center:

1. DISCONNECT LATHE FROM POWER!
2. Move the tailstock and tool rest a safe working distance from the headstock.
3. If the faceplate is installed, remove it (refer to **Page 22** for detailed instructions).
4. Make sure the spur center and the inside of the spindle are free of debris and oily substances that could interfere with proper mating of the parts.



5. Insert the tapered end of the center into the spindle, then push it in with a quick, firm motion (see **Figure 23**).

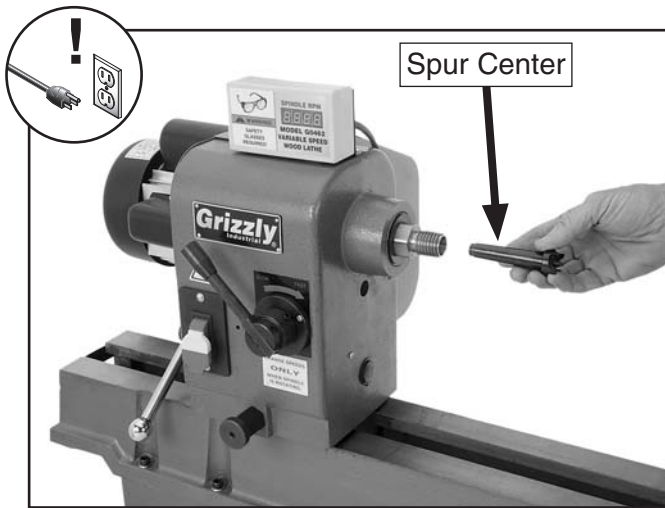
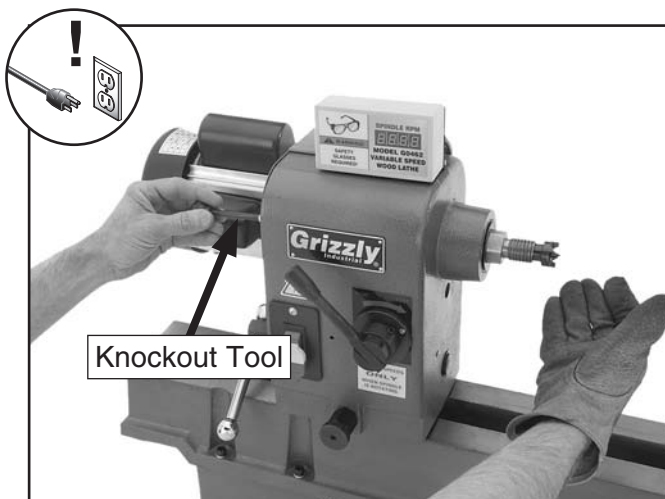

**Figure 23.** Inserting spur center into spindle.

6. Make sure the center is securely installed by attempting to pull it out by hand—a properly installed center will not pull out by hand.

#### To remove the spur center:

1. DISCONNECT LATHE FROM POWER!
2. Hold a clean rag under the spindle or wear a glove to catch the center when you remove it.
3. Insert the knockout tool through the outboard end of the spindle and firmly tap the center until it breaks loose (see **Figure 24**).



**Figure 24.** Removing spur center using the knockout tool.

## ⚠️ WARNING

Before beginning any turning operation that uses the live center installed into the tailstock quill, make sure the spur and live centers are properly aligned (refer to *Aligning Centers* on Page 33 for detailed instructions). Failure to heed this warning could result in the workpiece being thrown from the lathe, resulting in death or serious personal injury.

## Installing/Removing Live Center

The MT#2 live center installs into the tailstock quill and rotates with the workpiece.

#### To install the live center:

1. Move the tailstock a safe working distance from the head and tool rest.
2. Loosen the quill lock lever, then rotate the quill handwheel clockwise until the quill extends out from the tailstock about 1", as shown in **Figure 25**.

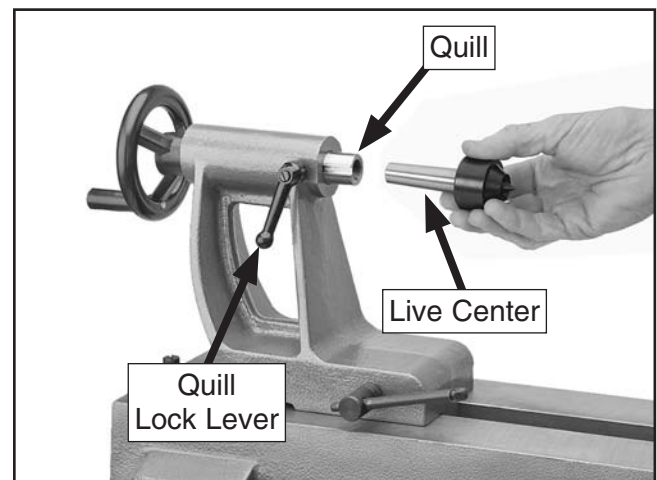

**Figure 25.** Installing the live center into the tailstock.

3. Make sure the live center and the inside of the quill are free of debris and oil substances that could interfere with the proper mating of these parts.
4. Insert the tapered end of the live center into the quill with a quick, firm motion.
5. Make sure the center is secure by attempting to pull it out by hand—a properly installed center will not pull out by hand.
6. Rotate the quill handwheel to draw the quill back into the tailstock as far as possible without forcing the center to release.

**Note:** *The more the quill is drawn back into the tailstock, the greater the workpiece support.*

7. Tighten the quill lock lever (see **Figure 25** on the previous page) to hold the quill and center in place.

## **!WARNING**

The tailstock quill lock lever **MUST** be tight and firmly secure the quill in place before beginning operation. Also, the quill should not protrude from the tailstock more than 2" or the quill will not adequately support the workpiece. Otherwise, the workpiece could come loose and fly at the operator or bystanders resulting in death or serious personal injury.

### To remove the live center:

1. Loosen the quill lock lever.
2. Hold a clean rag under the center or wear a glove to catch the center when you remove it.
3. Rotate the quill handwheel counterclockwise to retract the quill back into the tailstock until the center is forced out.

# Installing/Removing Faceplate

The faceplate is used when you need to remove material from the face of the workpiece, such as during hollowing operations. The faceplate can be installed only if the spur center is removed from the spindle.

### To install the faceplate:

1. **DISCONNECT LATHE FROM POWER!**
2. If the spur center is installed, remove it (refer to **Page 21** for detailed instructions).
3. Make sure the internal threads of the faceplate and the threads of the spindle are free of any debris, then wipe the threads with a lightly oiled rag to aid in the installation and removal.
4. Use the two included 32mm flat wrenches to tighten the faceplate, as shown in **Figure 26**.



**Figure 26.** Tightening the faceplate onto the spindle.

To remove the faceplate, perform **Steps 3–4** in reverse.

For detailed instructions on mounting a workpiece to the faceplate, refer to **Faceplate Turning** on **Page 26**.



# Selecting Turning Tools

Lathe tools come in a variety of shapes and sizes and usually fall into five major categories.

Refer to **Accessories** on **Page 28** for examples of recommended wood chisels from Grizzly.

- **Gouges**—Mainly used for rough cutting, detail cutting, and cove profiles. The rough gouge is a hollow, double-ground tool with a round nose, and the detail gouge is a hollow, double-ground tool with either a round or pointed nose. **Figure 27** shows an example of a gouge.

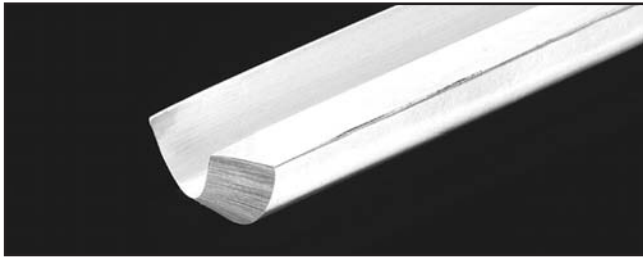

**Figure 27.** Gouge.

- **Skew Chisel**—A very versatile tool that can be used for planing, squaring, V-cutting, beading, and parting off. The skew chisel is flat, double-ground with one side higher than the other (usually at an angle of 20-40°). **Figure 28** shows an example of a skew chisel.

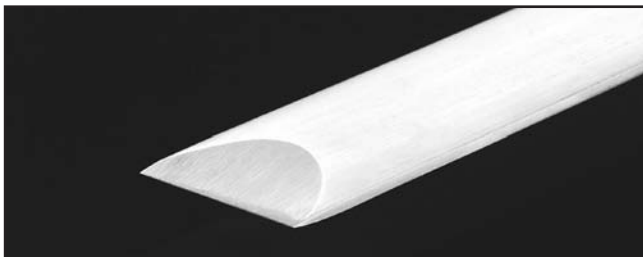

**Figure 28.** Skew chisel.

- **Scrapers**—Mainly used where access for other tools is limited, such as hollowing operations. This is a flat, double-ground tool that comes in a variety of profiles (Round Nose, Spear Point, Square Nose, etc.) to match many different contours. **Figure 29** shows an example of a round nose scraper.



**Figure 29.** Round nose scraper.

- **Parting Tools**—Used for sizing and cutting off work. This is a flat tool with a sharp pointed nose that may be single- or double-ground. **Figure 30** shows an example of a parting tool.



**Figure 30.** Parting tool.

- **Specialty Tools**—These are the unique, special function tools to aid in hollowing, bowl making, cutting profiles, etc. The Swan Neck Hollowing Tool shown on **Page 29** is a good example of a specialty tool.

# Spindle Turning

Spindle turning, as shown in **Figure 31**, is the operation performed when a workpiece is mounted between the spindle and quill centers.



**Figure 31.** Typical spindle turning operation.

## **⚠️ WARNING**

Before beginning any turning operation that uses the live center installed into the tailstock quill, make sure the spur and live centers are properly aligned (refer to *Aligning Centers* on Page 33 for detailed instructions). Failure to heed this warning could result in the workpiece being thrown from the lathe resulting in death or serious personal injury.

To set up a spindle turning operation:

1. Mark both ends of your workpiece by drawing diagonal lines from corner to corner. The intersection point of these lines will show you the center of your workpiece. See the illustration in **Figure 32** for details.

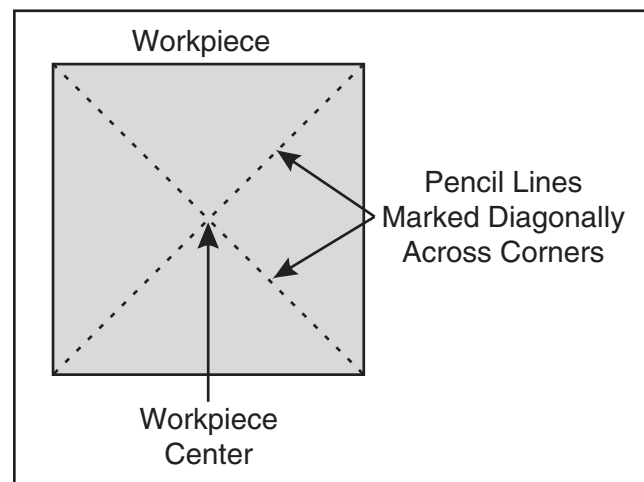

**Figure 32.** Workpiece marked diagonally from corner to corner to determine the center.

2. Use a wood mallet to tap the point of the spur center into the workpiece where the lines intersect so that it leaves a center mark, then remove the center. Do this to both ends of the workpiece.
3. Use a  $\frac{1}{4}$ " drill bit to make a  $\frac{1}{4}$ " deep hole at the center mark on the workpiece end that will be mounted on the spindle spur center.
4. To help embed the spur center into the workpiece, cut  $\frac{1}{8}$ " deep saw kerfs into the same workpiece end along the diagonal lines marked in **Step 1**.
5. If your workpiece is over 2" x 2", cut the corners off the workpiece length-wise to make turning the corners safer and easier.

- Use a wood mallet to embed the spur center at least  $\frac{1}{4}$ " into the workpiece end center mark, as illustrated in **Figure 33**.

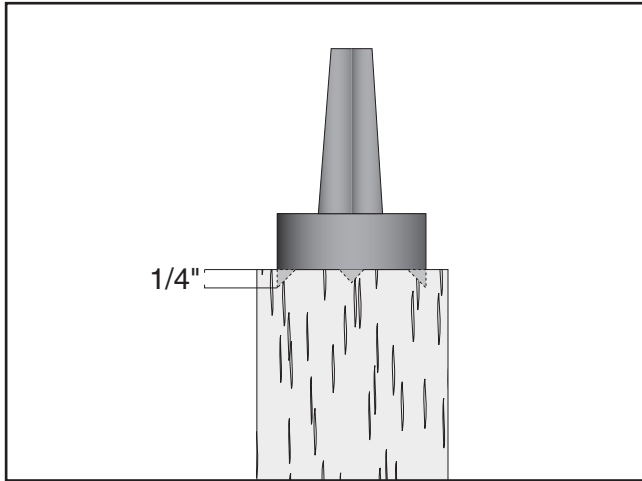

**Figure 33.** Spur center properly embedded.

- With the workpiece still attached, insert the spur center into the spindle.
- With the live center installed in the quill, draw the quill back into the spindle as far as possible without forcing the center to release.

**Note:** *This will give the quill and center the greatest amount of support to safely hold the workpiece during operation.*

- Loosen the tailstock lock lever, slide the tailstock toward the workpiece until the live center touches the workpiece centerpoint, then lock the tailstock in this position.
- Use the quill handwheel to push the live center into the workpiece at least a  $\frac{1}{4}$ ", then tighten the quill lock lever to secure the center and quill in place.

## **⚠️ WARNING**

**Do not press the live center into the workpiece too firmly or the center bearings will bind and overheat. Likewise, do not press the center too lightly or the workpiece could come loose and spin off the lathe. Use good judgement. Serious personal injury could result if care is not taken in this procedure.**

- Position the tool rest approximately  $\frac{1}{4}$ " away from the workpiece and approximately  $\frac{1}{8}$ " above the center line, as illustrated in **Figure 34**.

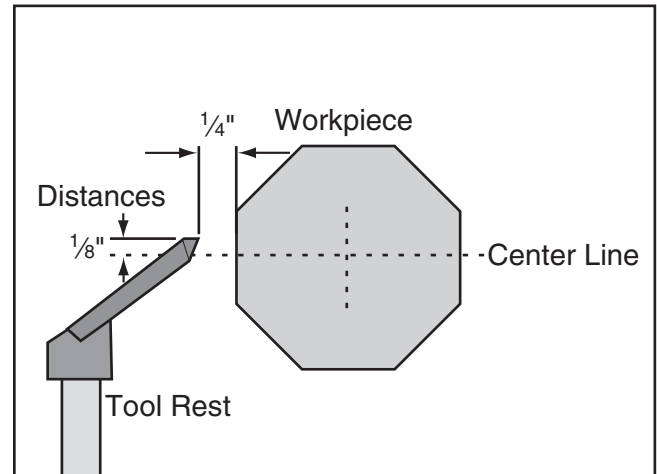

**Figure 34.** Tool rest set  $\frac{1}{8}$ " above the center line and  $\frac{1}{4}$ " away from workpiece.

- Test the setup by hand-turning the workpiece to make sure there is enough clearance all the way around before turning the lathe **ON**.

## **Spindle Turning Tips:**

- When turning the lathe **ON**, stand to the side of the spinning direction until the lathe reaches full speed and you can verify that the lathe will not throw the workpiece.
- Use the slowest speed when starting or stopping the lathe, and when rough cutting.
- Select the correct speed for the size of the workpiece you are turning. Use slower speeds for large workpieces (4" diameter and over); use the middle range speeds for medium sized workpieces (2"–4" diameter); and use faster speeds for small sized workpieces (under 2" in diameter).
- Keep the turning tool on the tool rest the ENTIRE time that it is approaching the workpiece and is in contact with it.
- Learn the correct techniques for each tool you will use. If you are unsure, read books or magazines about lathe techniques and seek training from experienced users.

# Faceplate Turning

Faceplate turning, as shown in **Figure 35**, is when a workpiece is mounted to the faceplate that is then mounted to the spindle. This type of turning is usually done with open-faced workpieces like bowls or plates.

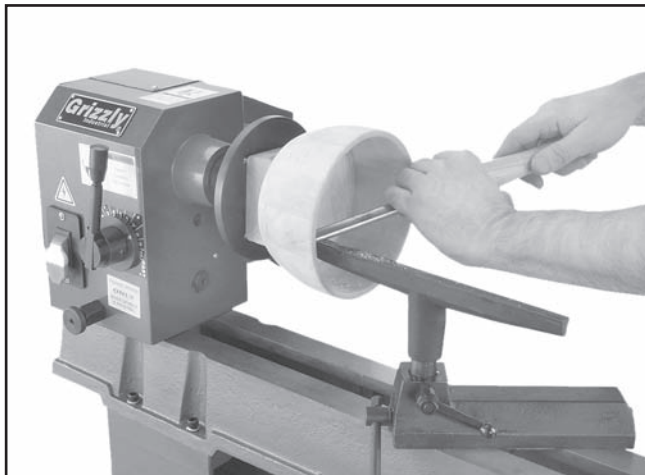

**Figure 35.** Typical faceplate turning operation.

## Attaching Faceplate to Workpiece

1. Mark the center of the workpiece back in the same manner as in **Spindle Turning** on **Page 24**.

**Note:** *Cut off the excess corners of the workpiece to make it as close to "round" as possible.*

## NOTICE

**DO NOT** use screws with tapered heads to attach the faceplate because they could split the faceplate, or the screws could snap off during operation. See the illustration in **Figure 36** for examples.

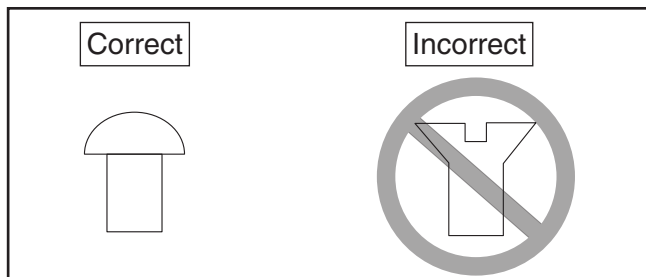

**Figure 36.** Correct screw type for faceplate attachment.

2. Use the mark made in **Step 1** to center the faceplate onto the workpiece back, then attach it with wood screws that do not have tapered heads (see **Figure 37** for an example).

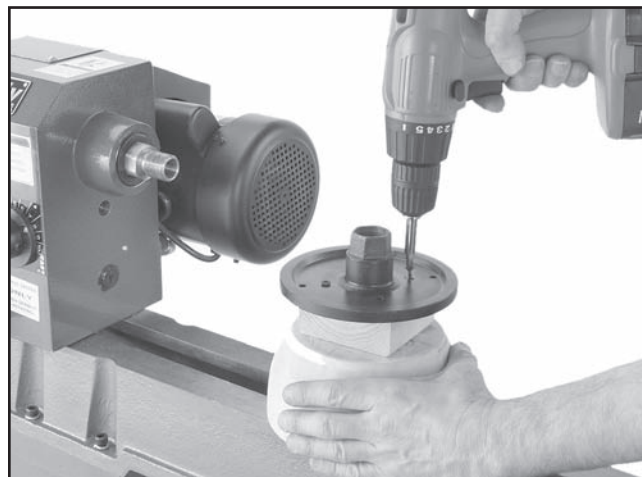

**Figure 37.** Attaching the faceplate to a backing block, which is glued to the workpiece.

3. Thread the faceplate onto the spindle and tighten securely.

## Using a Backing Block

If wood screws cannot be used to attach the faceplate to the workpiece, then use a backing block that is securely glued to the workpiece.

### To mount your workpiece to a backing block:

1. Make the backing block from a piece of scrap wood that is flat on both sides and free of knots or splits.
2. Locate and mark the center of both the workpiece and the backing block.
3. Drill a  $\frac{1}{4}$ " hole completely through the center of the backing block.
4. Looking through the hole in the backing block to line it up with the center of the workpiece, glue and clamp the backing block to the workpiece.

**Note:** *Allow the glue joint to completely cure according to the manufacturer's instructions.*

5. Follow the instructions above to attach the faceplate to the backing block.



# Outboard Turning

Outboard turning is a variation of faceplate turning and is usually done when stock diameter is greater than 12". For the size of the Model G0462 and its minimum turning speed, we recommend a maximum diameter of 17" for outboard turning.

The lathe setup at 90° for outboard turning uses the tool rest with the pivot arm extended, as shown in **Figure 38**.

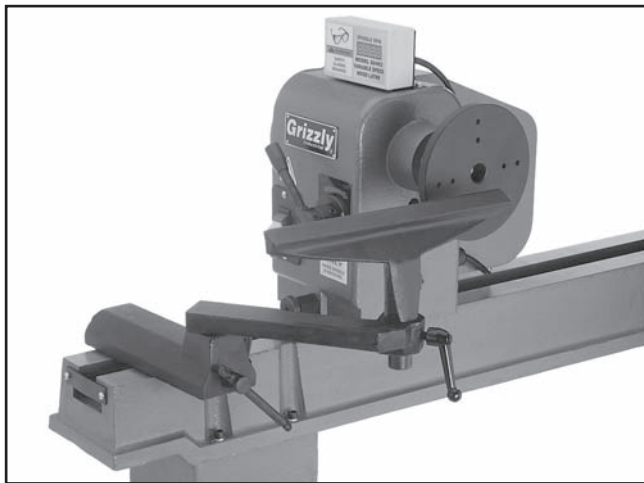

**Figure 38.** Headstock set at 90°.

**Figure 39** depicts the lathe setup at 180° for outboard turning.

**Note:** When turning in this manner, you must use a free standing tool rest (not supplied).

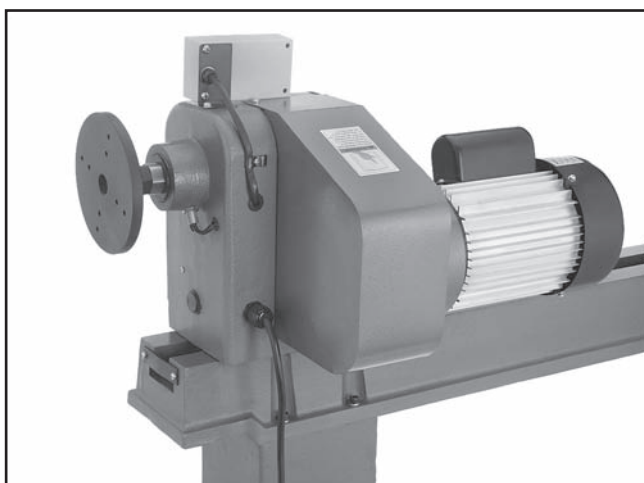
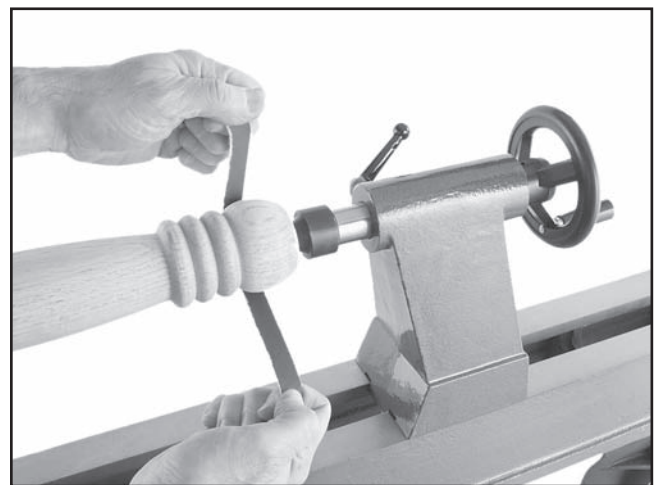

**Figure 39.** Headstock set at 180°.

# Sanding/Finishing Using the Lathe

The lathe can be used for finishing procedures after the turning operations are complete and before removing the workpiece from the lathe, such as sanding, polishing, and applying finishes by hand (see **Figure 40** for an example).

**Note:** When using the lathe to sand or finish the workpiece, remove the tool rest to prevent entanglement hazards. Use the slowest speed for safer control and better results.



**Figure 40.** Typical sanding operation.

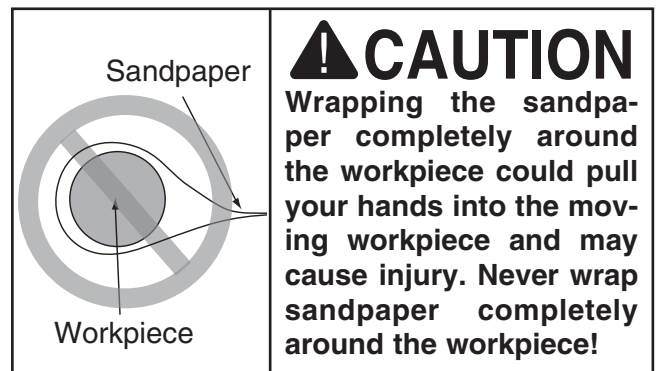

# SECTION 5: ACCESSORIES

## **⚠️ WARNING**

Using accessories not recommended for this machine could cause the machine to function differently than intended, which may increase the risk of serious personal injury. Only use recommended accessories for this machine.

### **G1194—3-Jaw Chuck**

A "must have" for the serious wood turner. This 3-jaw chuck is a self-centering style chuck used mostly for round work. All three jaws tighten together at the same time. Jaws are reversible for expanded work holding capacity. *Threaded insert required for mounting!*



**Figure 41.** Model G1194 3-Jaw Chuck.

### **G1082—4-Jaw Chuck**

Another "must have" for the serious wood turner. This 4-jaw chuck is an independent type chuck that is used for square and odd-shaped pieces. Each jaw tightens individually and can be turned around to hold larger dimension workpieces. *Threaded insert required for mounting!*

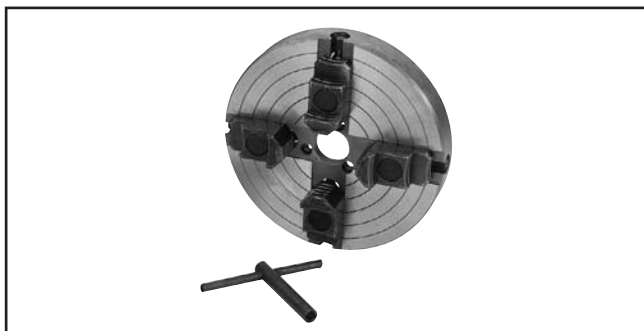

**Figure 42.** Model G1082 4-Jaw Chuck.

### **G3165—1" x 12 TPI RH Threaded Insert**

This threaded insert is required to mount a 3- or 4-jaw chuck to your wood lathe.

### **H5569—Steady Rest w/Ball Bearing Guides**

Perfect for stabilizing thin workpieces and eliminating chatter. Turning capacity is 1/8"–3/4".

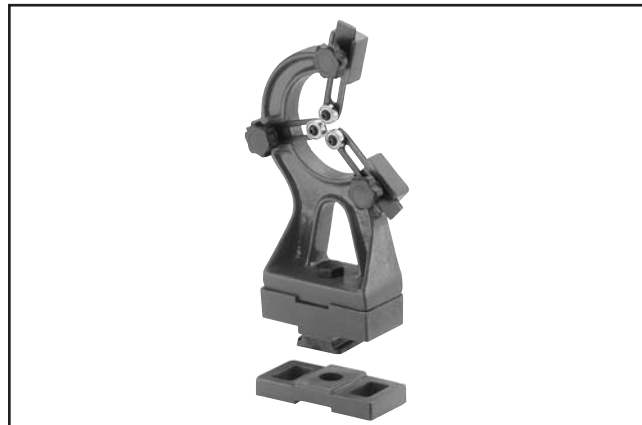

**Figure 43.** Model H5569 Steady Rest.

### **H1064—6-PC Deluxe HSS Lathe Chisel Set**

This deluxe chisel set features beefy ash handles for unsurpassed control, brass ferrules and high speed steel blades. Includes: a 17" long 13/16" Parting Tool, 13/16" Round Nose and 3/8" Gouge; a 19" long 1" Skew, a 5/8" Gouge and a 22 3/4" long 3/8" Gouge. Comes in a beautiful blow molded carrying case. An extremely popular set!



**Figure 44.** Model H1064 6-PC Chisel Set.

**Call 1-800-523-4777 To Order**



**H6542—Robert Sorby HSS 8-PC Turning Set**  
 If quality is king, then start bowing. Made in England, these Robert Sorby lathe tools are especially for the perfectionist wood turner. Includes  $\frac{3}{4}$ " roughing gouge,  $\frac{3}{8}$ " &  $\frac{1}{2}$ " spindle gouge,  $\frac{3}{8}$ " bowl gouge,  $\frac{3}{4}$ " standard skew,  $\frac{3}{16}$ " diamond side cut scraper, 1" square scraper and  $\frac{1}{2}$ " round scraper. Full size handles are 16"–19".



**Figure 45.** Model H6542 Robert Sorby 8-PC Set.

**G9863—8-PC HSS Lathe Chisel Set**  
 This chisel set features beautiful 8" ash handles with brass ferrules and  $3\frac{1}{2}$ " long, high speed steel blades. Chisels include:  $\frac{1}{2}$ " parting tool,  $\frac{1}{2}$ " straight chisel,  $\frac{1}{2}$ " double bevel skew,  $\frac{1}{2}$ " roundnose,  $\frac{3}{4}$ " gouge,  $\frac{3}{8}$ " gouge,  $\frac{1}{2}$ " diamond point and  $\frac{3}{8}$ " veiner. Set comes in fitted wooden case, and is very competitively priced!



**Figure 46.** Model G9863 8-PC Chisel Set.

**H6204—Precision Drill Chuck  $\frac{1}{32}$ "– $\frac{5}{8}$ " x JT#3**  
**G1676—Drill Chuck Arbor MT#2 x JT#3**  
 The best way to bore holes with your lathe!

**H0507—20" Swan Neck Hollowing Tool**  
**H0508—24" Swan Neck Hollowing Tool**  
 An excellent choice for blind turning or undercutting where reach is restricted. H0507 is designed for end grain use while H0508 (with a more substantial steel cross section) is designed for both end grain and side grain (bowl) use.



**Figure 47.** Swan Neck Hollowing Tools.

**H5954—Robert Sorby Stebcentre MT#2**  
 Razor sharp teeth bite into the workpiece for secure operation and the spring loaded center point controls the amount of drive or slip. This patented feature helps avoid the problem of "dig-in." Production turners can also load and unload their work while the lathe is still running!



**Figure 48.** Robert Sorby Stebcentre.

**Call 1-800-523-4777 To Order**

# SECTION 6: MAINTENANCE

---

---



## Schedule

---

---

For optimum performance from your machine, follow this maintenance schedule and refer to any specific instructions given in this section.

### Daily Check:

- Loose mounting bolts.
- Worn switch.
- Worn or damaged wires.
- Damaged V-belt.
- Any other unsafe condition.

## Cleaning

---

---

Cleaning the Model G0462 is relatively easy. Vacuum excess wood chips and sawdust, and wipe off the remaining dust with a dry cloth. If any resin has built up, use a resin dissolving cleaner to remove it.

Remove any debris or oily substances from inside the spindle and quill.

## Lathe Bed

---

---

Protect the unpainted cast iron lathe bed by wiping it clean after every use—this ensures moisture from wood dust does not remain on the bare metal surfaces. Keep your lathe bed rust-free with regular applications of quality lubricants.

## Tailstock

---

---

To remove the quill from the tailstock, loosen the set screw above the quill handwheel, then completely unthread the handwheel clockwise from the quill threads. Loosen the quill lock lever and remove the quill from the tailstock housing. Thoroughly clean all of the unpainted parts with mineral spirits. After these surfaces are dry, apply a thin coat of light machine oil.

To re-assemble the quill and handwheel, insert the quill into the casting, then thread the handwheel counterclockwise onto the quill until it moves against the casting. Tighten down the set screw that secures the handwheel, then back the set screw off one full turn so that the handwheel can freely rotate.

## Lubrication

---

---

Since all the bearings for the Model G0462 are sealed and permanently lubricated, simply leave them alone unless they need to be replaced. Do not lubricate them.

Wipe a lightly oiled shop rag on the outside spindle threads. DO NOT allow any oil to get on the inside mating surface of the spindle.

Use the quill handwheel to extend the quill all the way out, then wipe the outside of the quill with a lightly oiled shop rag. DO NOT allow any oil to get on the inside quill mating surfaces.





# SECTION 7: SERVICE

Review the troubleshooting and procedures in this section to fix or adjust your machine if a problem develops. If you need replacement parts or you are unsure of your repair skills, then feel free to call our Technical Support at (570) 546-9663.

## Troubleshooting



### Motor & Electrical

Symptom	Possible Cause	Possible Solution
Motor will not start, or it growls on start up.	<ol style="list-style-type: none"> <li>1. Power supply fuse or circuit breaker has tripped.</li> <li>2. Motor fan cover is dented, stopping the fan from being able to spin.</li> <li>3. Paddle switch is broken or at fault.</li> <li>4. Start capacitor is at fault.</li> <li>5. Motor is at fault.</li> </ol>	<ol style="list-style-type: none"> <li>1. Disconnect power, and inspect circuit for electrical shorts and repair. Replace circuit breaker if it is old or has tripped many times.</li> <li>2. Replace or adjust fan cover. Inspect motor fan and replace if damaged.</li> <li>3. Disconnect power, and use an ohmmeter to check switch terminals for continuity, and replace switch if required.</li> <li>4. Replace start capacitor.</li> <li>5. Replace motor.</li> </ol>
Fuses or circuit breakers trip open.	<ol style="list-style-type: none"> <li>1. Short circuit in line cord or plug.</li> <li>2. Short circuit in motor or loose connections.</li> <li>3. Incorrect fuses or circuit breakers in power supply.</li> </ol>	<ol style="list-style-type: none"> <li>1. Short circuit in line cord or plug.</li> <li>2. Short circuit in motor or loose connections.</li> <li>3. Incorrect fuses or circuit breakers in power supply.</li> </ol>
Vibration noise while machine is running; noise changes when speed is changed.	<ol style="list-style-type: none"> <li>1. V-Belt cover loose.</li> <li>2. V-Belt cover bent or dented and is making contact with the motor pulley or V-belt.</li> <li>3. Bad spindle bearing(s).</li> </ol>	<ol style="list-style-type: none"> <li>1. Tighten the four screws that mount the V-belt cover; if necessary, install a soft, vibration dampening material between the V-belt cover and the headstock casting.</li> <li>2. Remove V-belt cover and inspect the inside for dents, bends, or indications of rubbing. Tap out the dent with a rubber mallet, bend back into proper shape, or shim V-belt cover away from the motor pulley.</li> <li>3. Replace spindle bearing(s).</li> </ol>
Vibration noise while machine is running; noise remains constant when speed is changed.	<ol style="list-style-type: none"> <li>1. Dented fan cover on motor.</li> <li>2. Bad spindle bearing(s).</li> </ol>	<ol style="list-style-type: none"> <li>1. Replace or adjust fan cover. Inspect motor fan and replace if damaged.</li> <li>2. Replace spindle bearing(s).</li> </ol>
Bad surface finish.	<ol style="list-style-type: none"> <li>1. Wrong spindle speed.</li> <li>2. Dull chisel or wrong chisel being used for the operation.</li> </ol>	<ol style="list-style-type: none"> <li>1. Use trial-and-error to find a better spindle speed.</li> <li>2. Sharpen chisel or try a different chisel.</li> </ol>



Symptom	Possible Cause	Possible Solution
Inaccurate turning results from one end of the workpiece to the other.	1. Headstock and tailstock are not properly aligned with each other.	1. Realign the tailstock to the headstock ( <b>Page 33</b> ).
Can't remove tapered tool from quill.	1. Quill has not retracted all the way back into the tailstock. 2. Debris was not removed from taper before inserting into quill.	1. Turn the quill handwheel until it forces taper out of quill. 2. Always make sure that taper surfaces are clean.
Quill will not move forward into workpiece when handwheel is turned.	1. Keyway not aligned with the quill lock lever.	1. Align the quill keyway with the quill lock lever as shown in <b>Figure 13</b> , on <b>Page 16</b> and slightly tighten the lever to engage the keyway.



# Aligning Centers

To ensure accurate and safe results, make sure that the spindle and quill centers are aligned before beginning operations.

## To align the centers:

1. DISCONNECT LATHE FROM POWER!
2. Remove the tool rest from the bed.
3. Install the centers, then slide the tailstock up to the head so that the centers are facing each other, as illustrated in **Figure 49**.

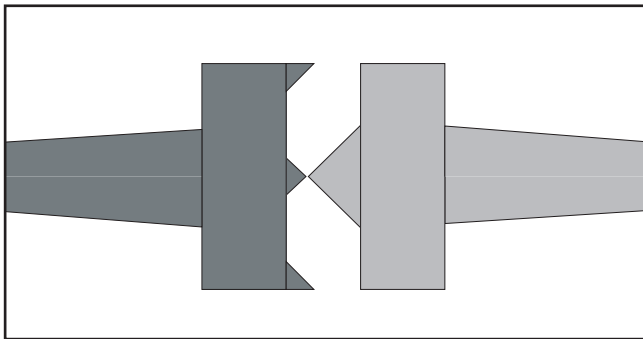

**Figure 49.** Center tips touching to ensure alignment.

4. Loosen the head lock lever, adjust the head position so that center tips touch, then re-tighten the lock lever to hold the head in place.

**Note:** If the spur center is lower than the live center, use shims under the head. If the live center is lower, use shims under the tailstock.

# Replacing V-Belt

The pulley system that allows the Model G0462 to operate at variable speeds also keeps the V-belt properly tensioned. However, if the V-belt shows signs of cracking, splitting, or any other damage, we recommend you replace it to ensure optimum power transmission.

## To replace the V-belt:

1. DISCONNECT LATHE FROM POWER!
2. Remove the V-belt safety cover from the back of the lathe.
3. Pull the motor pulley plates apart so that the V-belt slips down to the motor arbor, as shown in **Figure 50**. This will decrease the V-belt tension.

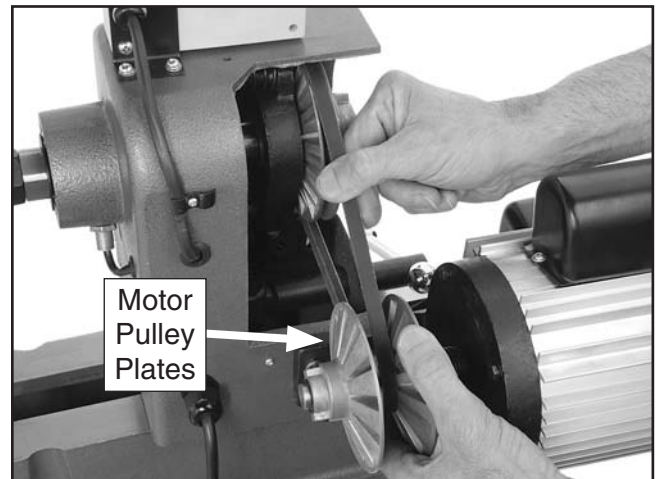

**Figure 50.** Replacing the V-belt.

4. While keeping the tension off the V-belt, roll it off the spindle pulley and remove it.
5. Install the new V-belt by reversing **Steps 3–4**.
6. Re-install the V-belt safety cover before connecting the lathe to power.



# SECTION 8: WIRING & ELECTRICAL

These pages are current at the time of printing. However, in the spirit of improvement, we may make changes to the electrical systems of future machines. Study this section carefully. If there are differences between your machine and what is shown in this section, call Technical Support at (570) 546-9663 for assistance BEFORE making any changes to the wiring on your machine.

## WARNING















### Wiring Safety Instructions

- SHOCK HAZARD.** Working on wiring that is connected to a power source is extremely dangerous. Touching electrified parts will result in personal injury including but not limited to severe burns, electrocution, or death. Disconnect the power from the machine before servicing electrical components!
- MODIFICATIONS.** Modifying the wiring beyond what is shown in the diagram may lead to unpredictable results, including serious injury or fire. This includes the installation of unapproved aftermarket parts.
- WIRE CONNECTIONS.** All connections must be tight to prevent wires from loosening during machine operation. Double-check all wires disconnected or connected during any wiring task to ensure tight connections.
- CIRCUIT REQUIREMENTS.** You MUST follow the requirements at the beginning of this manual when connecting your machine to a power source.
- WIRE/COMPONENT DAMAGE.** Damaged wires or components increase the risk of serious personal injury, fire, or machine damage. If you notice that any wires or components are damaged while performing a wiring task, replace those wires or components.
- MOTOR WIRING.** The motor wiring shown in these diagrams is current at the time of printing but may not match your machine. If you find this to be the case, use the wiring diagram inside the motor junction box.
- CAPACITORS/INVERTERS.** Some capacitors and power inverters store an electrical charge for up to 10 minutes after being disconnected from the power source. To reduce the risk of being shocked, wait at least this long before working on capacitors.
- EXPERIENCING DIFFICULTIES.** If you are experiencing difficulties understanding the information included in this section, contact our Technical Support at (570) 546-9663.

#### NOTICE

The photos and diagrams included in this section are best viewed in color. You can view these pages in color at [www.grizzly.com](http://www.grizzly.com).

#### COLOR KEY

BLACK 	BLUE 	YELLOW 	LIGHT BLUE 
WHITE 	BROWN 	YELLOW GREEN 	BLUE WHITE 
GREEN 	GRAY 	PURPLE 	TURQUOISE 
RED 	ORANGE 	PINK 	



# Electrical Components & Wiring Diagram



Figure 51. Paddle switch wiring.



Figure 52. Motor wiring.

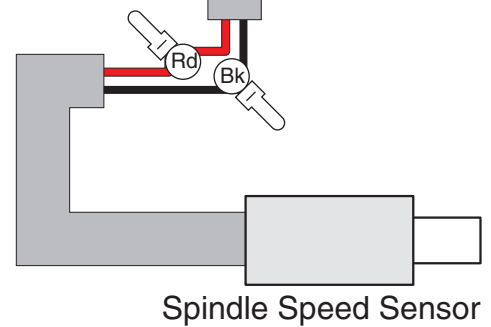
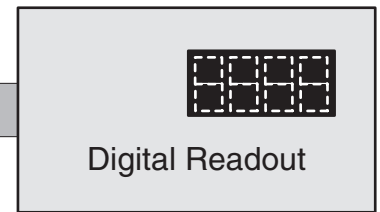
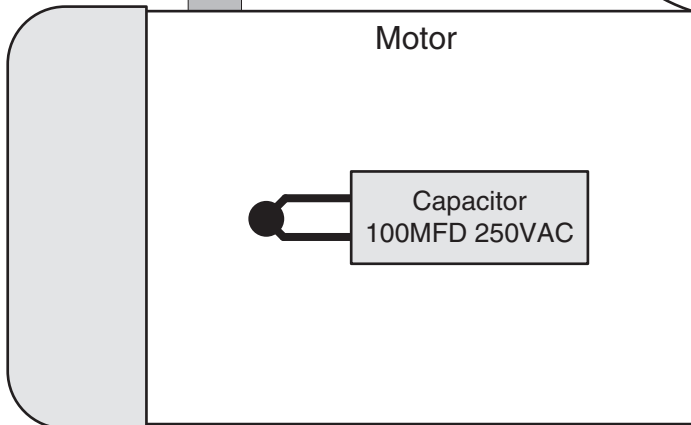
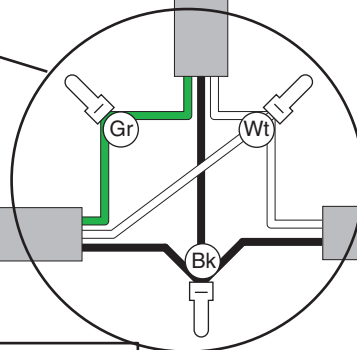
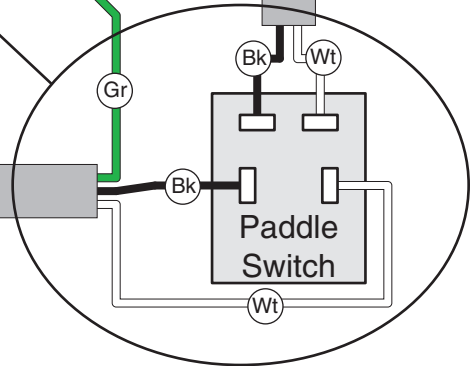
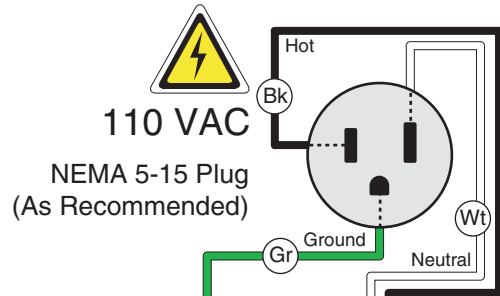

# SECTION 9: PARTS

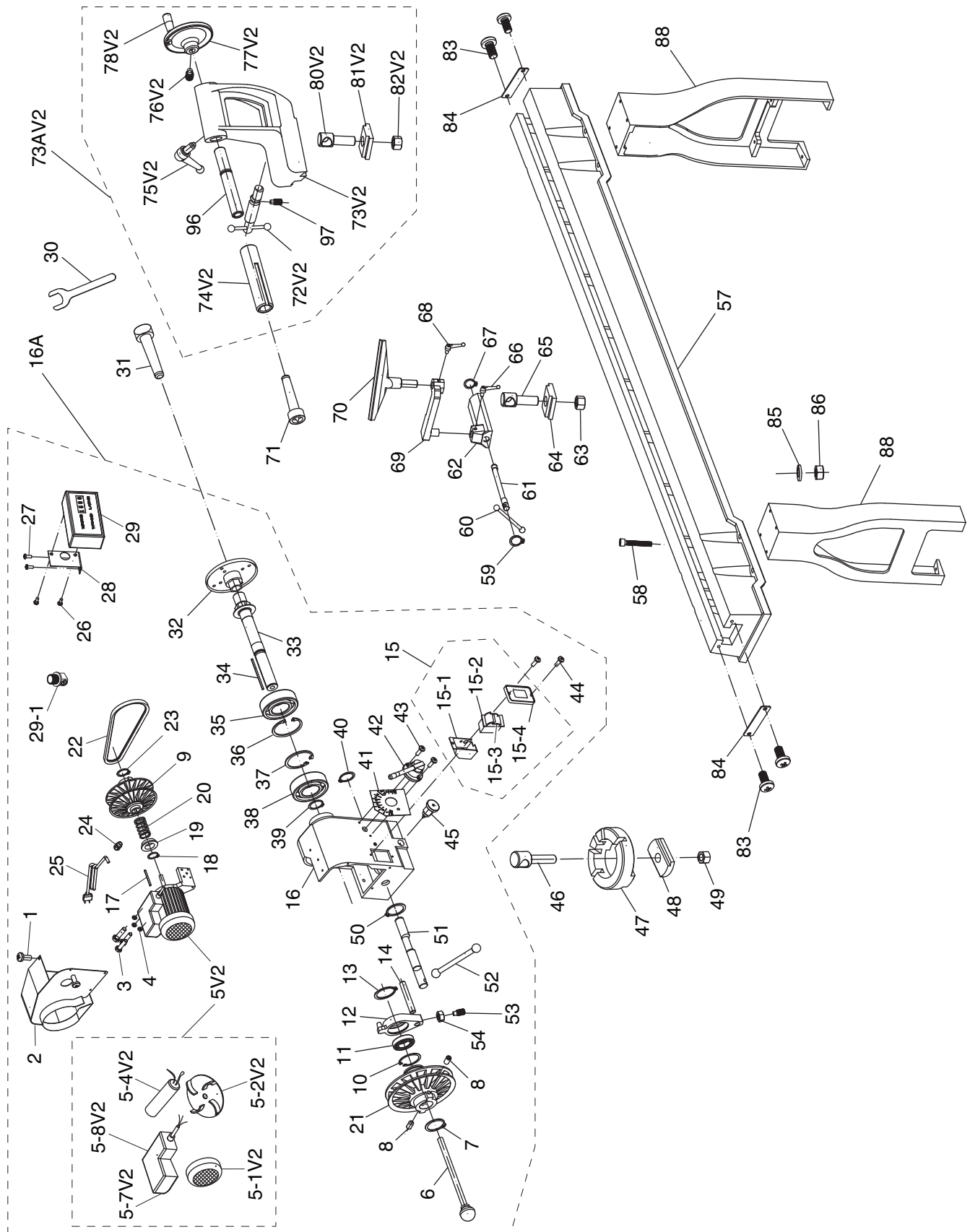

# Parts List

REF	PART #	DESCRIPTION
1	PS05M	PHLP HD SCR M5-.8 X 8
2	P0462002	MOTOR COVER
3	PB26M	HEX BOLT M8-1.25 X 30
4	PLW04M	LOCK WASHER 8MM
5V2	P0462005V2	MOTOR 2HP 110V 60HZ V2.01.09
5-1V2	P0462005-1V2	FAN COVER 156 X 68MM V2.01.09
5-2V2	P0462005-2V2	FAN 150 X 30MM V2.01.09
5-4V2	P0462005-4V2	S CAPACITOR 100M 250V V2.01.09
5-7V2	P0462005-7V2	MOTOR JUNCTION BOX V2.01.09
6	P0584022	KNOCKOUT TOOL
7	PR12M	EXT RETAINING RING 35MM
8	P0584026	CENTER-DRILLED SET SCR M6 X 10
9	P0462009	MOTOR PULLEY SET
10	PR38M	INT RETAINING RING 62MM
11	P6007ZZ	BALL BEARING 6007 ZZ
12	P0584009	SHIFTING LEVER BRACKET
13	PR12M	EXT RETAINING RING 35MM
14	P0462014	RACK
15	P0462015	SWITCH ASSEMBLY
15-1	P0584070	SWITCH BOX
15-2	G8988	GRIZZLY PADDLE SWITCH W/KEY
15-3	PSW09-1	PADDLE SWITCH KEY
15-4	P0584072	SWITCH BOX PLATE
16	P0462016	HEADSTOCK CASTING
16A	P0462016A	HEADSTOCK ASSEMBLY
17	PK93M	KEY 4 X 4 X 80
18	PR06M	EXT RETAINING RING 16MM
19	P0584020	MOTOR SHAFT SLEEVE
20	P0584019	COMPRESSION SPRING
21	P0462021	SPINDLE PULLEY SET
22	PVM24.5	V-BELT M24.5 3L245
23	PR06M	EXT RETAINING RING 16MM
24	P0462024	STRAIN RELIEF M20-1.5
25	P0462025	POWER CORD 16G 3W 5-15 PLUG
26	PS68M	PHLP HD SCR M6-1 X 10
27	PS68M	PHLP HD SCR M6-1 X 10
28	P0462028	DIGITAL READOUT BRACKET
29	P0462029	DIGITAL READOUT ASSEMBLY
29-1	P0462029-1	RPM SENSOR
30	P0584084	FLAT WRENCH 32MM
31	P0584003	SPUR CENTER MT#2
32	P0462032	FACEPLATE 6"
33	P0462033	SPINDLE 1" X 8"
34	PK93M	KEY 4 X 4 X 80
35	P6205ZZ	BALL BEARING 6205ZZ
36	PR26M	INT RETAINING RING 52MM
37	PR26M	INT RETAINING RING 52MM
38	P6205ZZ	BALL BEARING 6205ZZ
39	PR11M	EXT RETAINING RING 25MM

REF	PART #	DESCRIPTION
40	PR58M	EXT RETAINING RING 24MM
41	P0462041	SPEED CHANGE LABEL
42	P0584048	SPEED CONTROL LEVER ASSY
43	PS08M	PHLP HD SCR M5-.8 X 12
44	PS02M	PHLP HD SCR M4-.7 X 12
45	P0584045	HEAD PIVOT LOCKING PIN
46	P0462046	HEADSTOCK PIVOT BOLT
47	P0584037	HEAD PIVOT BASE
48	P0584043	HEAD CLAMP PLATE
49	PN29M	HEX NUT M18-2.5
50	PR58M	EXT RETAINING RING 24MM
51	P0462051	HEADSTOCK ECCENTRIC SHAFT
52	P0462052	HEAD LOCK LEVER
53	PSS21M	SET SCREW M8-1.25 X 25
54	PN03M	HEX NUT M8-1.25
57	P0584038	BED
58	PCAP12M	CAP SCREW M8-1.25 X 40
59	PR08M	EXT RETAINING RING 19MM
60	P0462060	BALL LEVER
61	P0584055	TOOL REST ECCENTRIC SHAFT
62	P0584056	TOOL REST BASE
63	PN29M	HEX NUT M18-2.5
64	P0462064	TOOL REST CLAMP PLATE
65	P0462065	TOOL REST PIVOT BOLT
66	P0584057	LOCK HANDLE ASSY M10-1.5 X 15
67	PR08M	EXT RETAINING RING 19MM
68	P0584057	LOCK HANDLE ASSY M10-1.5 X 15
69	P0584058	TOOL REST PIVOT ARM
70	P0462070	TOOL REST 12-1/8"L X 6-1/2"H
71	P0584061	TAILSTOCK LIVE CENTER MT#2
72V2	G0462072V2	TAILSTOCK LOCK LEVER V2.11.09
73V2	P0462073V2	TAILSTOCK CASTING V2.11.09
73AV2	P0462073AV2	TAILSTOCK ASSEMBLY V2.11.09
74V2	P0462074V2	TAILSTOCK QUILL V2.11.09
75V2	P0462075V2	QUILL LOCK HANDLE ASSY V2.11.09
76V2	P0462076V2	HANDWHEEL SET SCREW V2.11.09
77V2	P0462077V2	TAILSTOCK HANDWHEEL V2.11.09
78V2	P0462078V2	HANDWHEEL HANDLE V2.11.09
80V2	P0462080V2	TAILSTOCK PIVOT BOLT V2.11.09
81V2	P0462081V2	TAILSTOCK CLAMP PLATE V2.11.09
82V2	PN29M	HEX NUT M18-2.5
83	PS08M	PHLP HD SCR M5-.8 X 12
84	P0462084	BED END PLATE
85	PLW04M	LOCK WASHER 8MM
86	PN03M	HEX NUT M8-1.25
88	P0462088	STAND LEG LEFT/RIGHT
96V2	P0462096V2	TAILSTOCK LEADSCREW V2.11.09
97	PSS04M	SET SCREW M6-1 X 12



# Machine Labels

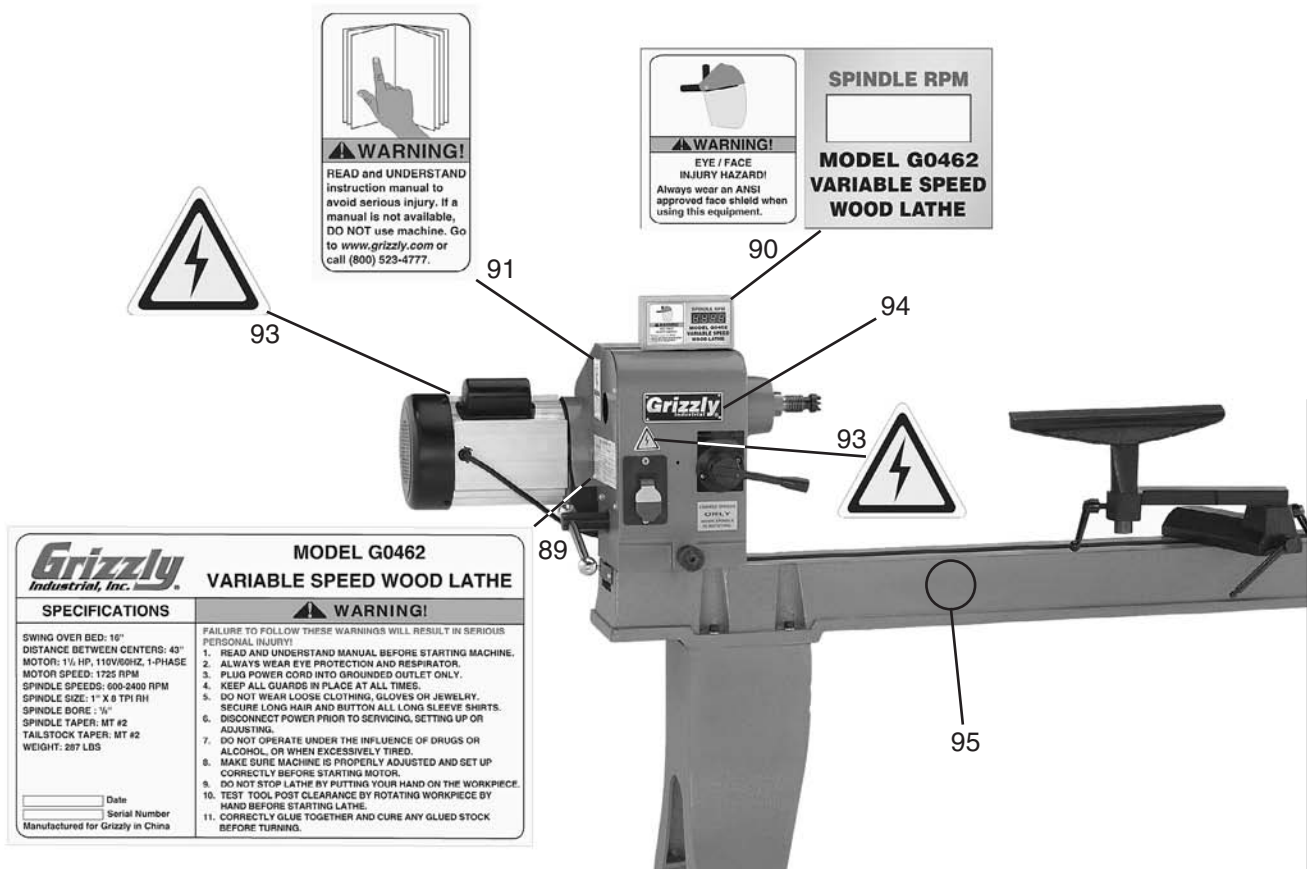

<b>MODEL G0462 VARIABLE SPEED WOOD LATHE</b>	
<b>SPECIFICATIONS</b> SWING OVER BED: 16" DISTANCE BETWEEN CENTERS: 43" MOTOR: 1/2 HP, 115V/60HZ, 1-PHASE MOTOR SPEED: 1725 RPM SPINDLE SPEEDS: 600-2400 RPM SPINDLE SIZE: 1" X 8 TPI RH SPINDLE BORE: 1/2" SPINDLE TAPER: MT #2 TAILSTOCK TAPER: MT #2 WEIGHT: 287 LBS	<b>WARNING!</b> FAILURE TO FOLLOW THESE WARNINGS WILL RESULT IN SERIOUS PERSONAL INJURY! 1. READ AND UNDERSTAND MANUAL BEFORE STARTING MACHINE. 2. ALWAYS WEAR EYE PROTECTION AND RESPIRATOR. 3. PLUG POWER CORD INTO GROUNDED OUTLET ONLY. 4. KEEP ALL GUARDS IN PLACE AT ALL TIMES. 5. DO NOT WEAR LOOSE CLOTHING, GLOVES OR JEWELRY. SECURE LONG HAIR AND BUTTON ALL LONG SLEEVE SHIRTS. 6. DISCONNECT POWER PRIOR TO SERVICING, SETTING UP OR ADJUSTING. 7. DO NOT OPERATE UNDER THE INFLUENCE OF DRUGS OR ALCOHOL, OR WHEN EXCESSIVELY TIRED. 8. MAKE SURE MACHINE IS PROPERLY ADJUSTED AND SET UP CORRECTLY BEFORE STARTING MOTOR. 9. DO NOT STOP LATHE BY PUTTING YOUR HAND ON THE WORKPIECE. 10. TEST TOOL POST CLEARANCE BY ROTATING WORKPIECE BY HAND BEFORE STARTING LATHE. 11. CORRECTLY GLUE TOGETHER AND CURE ANY GLUED STOCK BEFORE TURNING.
_____ Date _____ Serial Number Manufactured for Grizzly in China	

REF	PART #	DESCRIPTION
89	P0462089	MACHINE ID LABEL
90	P0462090	RPM DISPLAY/FACE SHIELD LABEL
91	PLABEL-12A	READ MANUAL LABEL
92	P0462041	SPEED CHANGE LABEL

REF	PART #	DESCRIPTION
93	PLABEL-14	ELECTRICITY LABEL
94	P0584079	GRIZZLY LOGO LABEL
95	PPAINT-01	GRIZZLY GREEN TOUCH-UP PAINT

## WARNING

Safety labels warn about machine hazards and ways to prevent injury. The owner of this machine **MUST** maintain the original location and readability of the labels on the machine. If any label is removed or becomes unreadable, **REPLACE** that label before using the machine again. Contact Grizzly at (800) 523-4777 or [www.grizzly.com](http://www.grizzly.com) to order new labels.







# WARRANTY CARD

Name \_\_\_\_\_  
 Street \_\_\_\_\_  
 City \_\_\_\_\_ State \_\_\_\_\_ Zip \_\_\_\_\_  
 Phone # \_\_\_\_\_ Email \_\_\_\_\_ Invoice # \_\_\_\_\_  
 Model # \_\_\_\_\_ Order # \_\_\_\_\_ Serial # \_\_\_\_\_

The following information is given on a voluntary basis. It will be used for marketing purposes to help us develop better products and services. **Of course, all information is strictly confidential.**

- How did you learn about us?
 

<input type="checkbox"/> Advertisement	<input type="checkbox"/> Friend	<input type="checkbox"/> Catalog
<input type="checkbox"/> Card Deck	<input type="checkbox"/> Website	<input type="checkbox"/> Other:
- Which of the following magazines do you subscribe to?
 

<input type="checkbox"/> Cabinetmaker & FDM	<input type="checkbox"/> Popular Science	<input type="checkbox"/> Wooden Boat
<input type="checkbox"/> Family Handyman	<input type="checkbox"/> Popular Woodworking	<input type="checkbox"/> Woodshop News
<input type="checkbox"/> Hand Loader	<input type="checkbox"/> Precision Shooter	<input type="checkbox"/> Woodsmith
<input type="checkbox"/> Handy	<input type="checkbox"/> Projects in Metal	<input type="checkbox"/> Woodwork
<input type="checkbox"/> Home Shop Machinist	<input type="checkbox"/> RC Modeler	<input type="checkbox"/> Woodworker West
<input type="checkbox"/> Journal of Light Cont.	<input type="checkbox"/> Rifle	<input type="checkbox"/> Woodworker's Journal
<input type="checkbox"/> Live Steam	<input type="checkbox"/> Shop Notes	<input type="checkbox"/> Other:
<input type="checkbox"/> Model Airplane News	<input type="checkbox"/> Shotgun News	
<input type="checkbox"/> Old House Journal	<input type="checkbox"/> Today's Homeowner	
<input type="checkbox"/> Popular Mechanics	<input type="checkbox"/> Wood	
- What is your annual household income?
 

<input type="checkbox"/> \$20,000-\$29,000	<input type="checkbox"/> \$30,000-\$39,000	<input type="checkbox"/> \$40,000-\$49,000
<input type="checkbox"/> \$50,000-\$59,000	<input type="checkbox"/> \$60,000-\$69,000	<input type="checkbox"/> \$70,000+
- What is your age group?
 

<input type="checkbox"/> 20-29	<input type="checkbox"/> 30-39	<input type="checkbox"/> 40-49
<input type="checkbox"/> 50-59	<input type="checkbox"/> 60-69	<input type="checkbox"/> 70+
- How long have you been a woodworker/metalworker?
 

<input type="checkbox"/> 0-2 Years	<input type="checkbox"/> 2-8 Years	<input type="checkbox"/> 8-20 Years	<input type="checkbox"/> 20+ Years
------------------------------------	------------------------------------	-------------------------------------	------------------------------------
- How many of your machines or tools are Grizzly?
 

<input type="checkbox"/> 0-2	<input type="checkbox"/> 3-5	<input type="checkbox"/> 6-9	<input type="checkbox"/> 10+
------------------------------	------------------------------	------------------------------	------------------------------
- Do you think your machine represents a good value?  Yes  No
- Would you recommend Grizzly Industrial to a friend?  Yes  No
- Would you allow us to use your name as a reference for Grizzly customers in your area?  
**Note: We never use names more than 3 times.**  Yes  No

10. Comments: \_\_\_\_\_  
 \_\_\_\_\_  
 \_\_\_\_\_  
 \_\_\_\_\_

CUT ALONG DOTTED LINE

FOLD ALONG DOTTED LINE

\_\_\_\_\_

\_\_\_\_\_

\_\_\_\_\_



Place  
Stamp  
Here



GRIZZLY INDUSTRIAL, INC.  
P.O. BOX 2069  
BELLINGHAM, WA 98227-2069



FOLD ALONG DOTTED LINE

Send a Grizzly Catalog to a friend:

Name _____
Street _____
City _____ State _____ Zip _____

TAPE ALONG EDGES--PLEASE DO NOT STAPLE

# WARRANTY AND RETURNS

---

Grizzly Industrial, Inc. warrants every product it sells for a period of **1 year** to the original purchaser from the date of purchase. This warranty does not apply to defects due directly or indirectly to misuse, abuse, negligence, accidents, repairs or alterations or lack of maintenance. This is Grizzly's sole written warranty and any and all warranties that may be implied by law, including any merchantability or fitness, for any particular purpose, are hereby limited to the duration of this written warranty. We do not warrant or represent that the merchandise complies with the provisions of any law or acts unless the manufacturer so warrants. In no event shall Grizzly's liability under this warranty exceed the purchase price paid for the product and any legal actions brought against Grizzly shall be tried in the State of Washington, County of Whatcom.

We shall in no event be liable for death, injuries to persons or property or for incidental, contingent, special, or consequential damages arising from the use of our products.

To take advantage of this warranty, contact us by mail or phone and give us all the details. We will then issue you a "Return Number," which must be clearly posted on the outside as well as the inside of the carton. We will not accept any item back without this number. Proof of purchase must accompany the merchandise.

The manufacturers reserve the right to change specifications at any time because they constantly strive to achieve better quality equipment. We make every effort to ensure that our products meet high quality and durability standards and we hope you never need to use this warranty.

Please feel free to write or call us if you have any questions about the machine or the manual.

Thank you again for your business and continued support. We hope to serve you again soon.

# *grizzly.com*<sup>®</sup>

**TOOL WEBSITE**

Buy Direct and Save with Grizzly<sup>®</sup> – Trusted, Proven and a Great Value!  
~Since 1983~

*Visit Our Website Today For  
Current Specials!*

**ORDER  
24 HOURS A DAY!  
1-800-523-4777**



## Free Manuals Download Website

<http://myh66.com>

<http://usermanuals.us>

<http://www.somanuals.com>

<http://www.4manuals.cc>

<http://www.manual-lib.com>

<http://www.404manual.com>

<http://www.luxmanual.com>

<http://aubethermostatmanual.com>

Golf course search by state

<http://golfingnear.com>

Email search by domain

<http://emailbydomain.com>

Auto manuals search

<http://auto.somanuals.com>

TV manuals search

<http://tv.somanuals.com>