

# *Grizzly* **Industrial, Inc.**®

## **MODEL G0671/G0672/G0673 DUST COLLECTOR OWNER'S MANUAL**



COPYRIGHT © MAY, 2008 BY GRIZZLY INDUSTRIAL, INC.  
**WARNING: NO PORTION OF THIS MANUAL MAY BE REPRODUCED IN ANY SHAPE  
OR FORM WITHOUT THE WRITTEN APPROVAL OF GRIZZLY INDUSTRIAL, INC.**

#BLJB10749 PRINTED IN TAIWAN

# **WARNING!**

**This manual provides critical safety instructions on the proper setup, operation, maintenance and service of this machine/equipment.**

**Failure to read, understand and follow the instructions given in this manual may result in serious personal injury, including amputation, electrocution or death.**

**The owner of this machine/equipment is solely responsible for its safe use. This responsibility includes but is not limited to proper installation in a safe environment, personnel training and usage authorization, proper inspection and maintenance, manual availability and comprehension, application of safety devices, blade/cutter integrity, and the usage of personal protective equipment.**

**The manufacturer will not be held liable for injury or property damage from negligence, improper training, machine modifications or misuse.**

# **WARNING!**

**Some dust created by power sanding, sawing, grinding, drilling, and other construction activities contains chemicals known to the State of California to cause cancer, birth defects or other reproductive harm. Some examples of these chemicals are:**

- **Lead from lead-based paints.**
- **Crystalline silica from bricks, cement and other masonry products.**
- **Arsenic and chromium from chemically-treated lumber.**

**Your risk from these exposures varies, depending on how often you do this type of work. To reduce your exposure to these chemicals: Work in a well ventilated area, and work with approved safety equipment, such as those dust masks that are specially designed to filter out microscopic particles.**

# Table of Contents

<b>INTRODUCTION.....</b>	<b>2</b>	<b>SECTION 5: OPERATIONS .....</b>	<b>34</b>
Foreword.....	2	Operation Safety .....	34
Contact Info.....	2	Basic Controls.....	34
Functional Overview .....	2	General .....	34
Identification.....	3	<b>SECTION 6: ACCESSORIES.....</b>	<b>35</b>
G0671 Machine Data Sheet .....	4	<b>SECTION 7: MAINTENANCE.....</b>	<b>37</b>
G0672 Machine Data Sheet .....	7	Schedule .....	37
G0673 Machine Data Sheet .....	10	Lubrication .....	37
<b>SECTION 1: SAFETY.....</b>	<b>13</b>	Bag Cleaning .....	37
Safety Instructions for Machinery .....	13	<b>SECTION 8: SERVICE .....</b>	<b>38</b>
Additional Safety for Dust Collectors .....	15	Troubleshooting .....	38
<b>SECTION 2: CIRCUIT REQUIREMENTS .....</b>	<b>16</b>	<b>SECTION 9: WIRING.....</b>	<b>40</b>
Operation .....	16	Electrical Safety Instructions.....	40
<b>SECTION 3: SETUP .....</b>	<b>17</b>	G0671/G0672 Wiring Diagram .....	41
Setup Safety .....	17	G0673 Wiring Diagram .....	42
Items Needed for Setup.....	17	G0673 Electrical Components .....	43
Unpacking.....	17	<b>SECTION 10: PARTS.....</b>	<b>44</b>
G0671/G0672 Inventory.....	18	G0671 Parts Breakdown.....	44
G0673 Inventory .....	19	G0672 Parts Breakdown.....	46
Hardware Recognition Chart .....	20	G0673 Parts Breakdown.....	48
Site Considerations.....	21	Label Placement .....	50
Assembly .....	21	<b>WARRANTY AND RETURNS .....</b>	<b>53</b>
Test Run .....	25		
<b>SECTION 4: DESIGNING THE SYSTEM.....</b>	<b>26</b>		
General .....	26		
Duct Material.....	26		
System Design.....	28		
System Grounding .....	33		

# INTRODUCTION

---

---

## Foreword

---

---

We are proud to offer the Model G0671/G0672/G0673 Dust Collector. This machine is part of a growing Grizzly family of fine woodworking machinery. When used according to the guidelines set forth in this manual, you can expect years of trouble-free, enjoyable operation and proof of Grizzly's commitment to customer satisfaction.

The specifications, drawings, and photographs illustrated in this manual represent the Model G0671/G0672/G0673 when the manual was prepared. However, owing to Grizzly's policy of continuous improvement, changes may be made at any time with no obligation on the part of Grizzly. For your convenience, we always keep current Grizzly manuals available on our website at **www.grizzly.com**. Any updates to your machine will be reflected in these manuals as soon as they are complete. Visit our site often to check for the latest updates to this manual!

## Contact Info

---

---

We stand behind our machines. If you have any service questions, parts requests or general questions about the machine, please call or write us at the location listed below.

Grizzly Industrial, Inc.  
1203 Lycoming Mall Circle  
Muncy, PA 17756  
Phone: (570) 546-9663  
Fax: (800) 438-5901  
E-Mail: techsupport@grizzly.com

If you have any comments regarding this manual, please write to us at the address below:

Grizzly Industrial, Inc.  
c/o Technical Documentation Manager  
P.O. Box 2069  
Bellingham, WA 98227-2069  
Email: manuals@grizzly.com

## Functional Overview

---

---

This machine is designed to capture dust and wood chips from multiple woodworking machines at the same time, such as table saws, jointers, and planers.

The primary components of this dust collector are the motor, impeller, and lower dust collection and upper filtration bags.

This dust collector is designed to connect to a duct system in which each woodworking machine is connected to a single mainline via smaller branch lines. Alternatively, each intake port on the collector can be connected to an individual woodworking machine with flexible hose or rigid duct.

When the dust collector is turned on, the impeller rotates, pulling air in through the intake ports and forcing it out through the collection and filtration bags. The vacuum created draws air, dust, and chips produced from attached woodworking machines through the duct system to the impeller housing and into the collectors. Here, heavier particles fall into the collection bags while air and the remaining fine particles are forced into the filter bags. These bags capture most particles while still allowing the air to escape. To capture smaller particles, a fine filter can be purchased separately.

The dust collector should not be located near open flames, to reduce the risk of an explosion as a result of dust being dispersed into the air. The dust collection system must also be properly grounded to safely discharge static electrical buildup and prevent the risk of fire or explosions.

A wide variety of accessories for setting up a stationary or mobile dust collection system are available through Grizzly.



# Identification

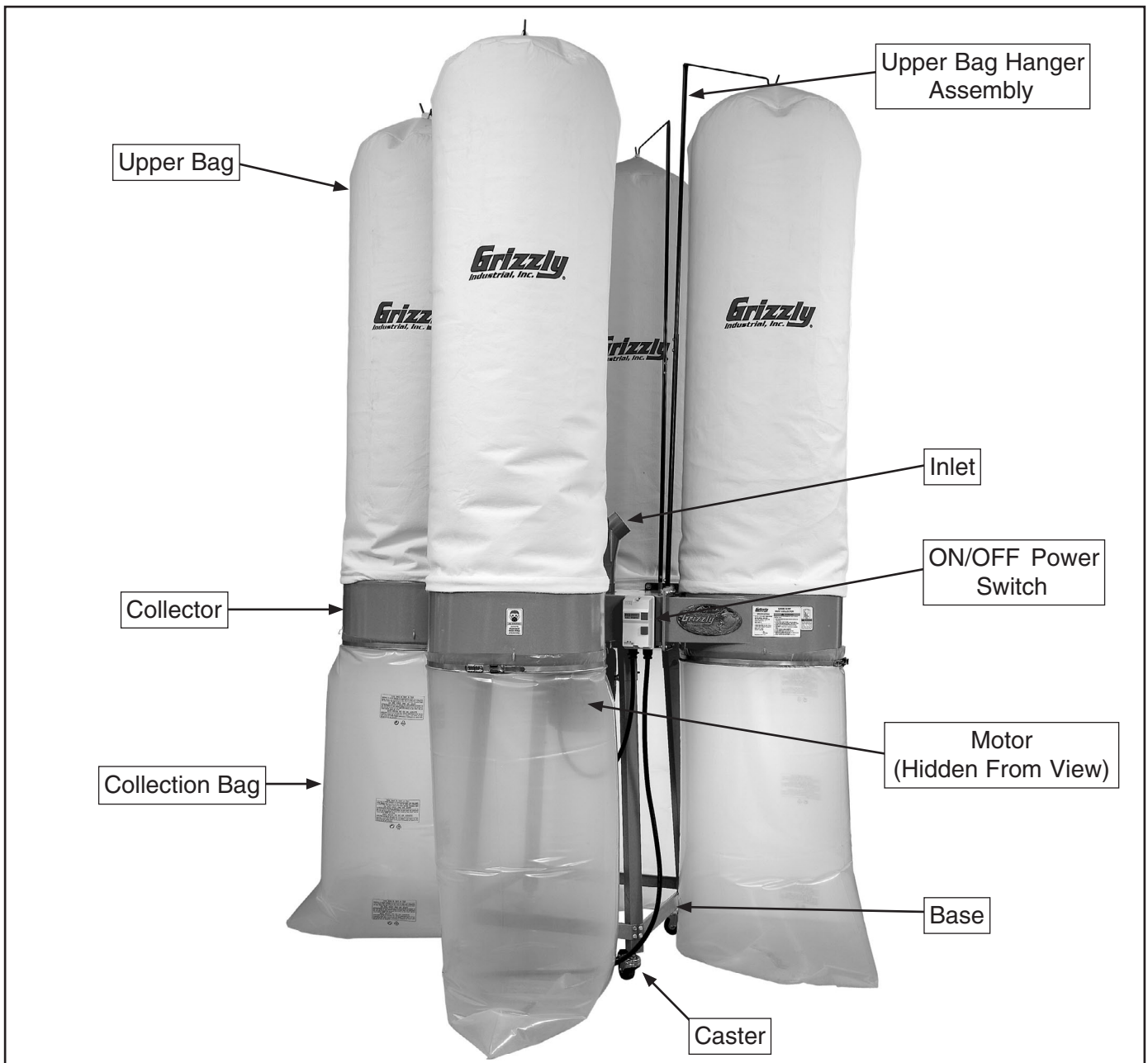

Figure 5. Model G0673 dust collector, front view.





# MACHINE DATA SHEET

Customer Service #: (570) 546-9663 • To Order Call: (800) 523-4777 • Fax #: (800) 438-5901

## MODEL G0671 4 HP DUST COLLECTOR

### Product Dimensions:

Weight ..... 370 lbs.  
Length/Width/Height ..... 73<sup>7</sup>/<sub>8</sub>" x 31<sup>3</sup>/<sub>8</sub>" x 101<sup>1</sup>/<sub>8</sub>"  
Foot Print (Length/Width)..... 73<sup>7</sup>/<sub>8</sub>" x 31<sup>3</sup>/<sub>8</sub>"

### Shipping Dimensions:

Type ..... Cardboard & Wood Frame  
Content..... Machine  
Weight ..... 315 lbs.  
Length/Width/Height..... 29" x 15" x 42"

### Electrical:

Switch..... ON/OFF Magnetic with Thermal Overload Protector  
Switch Voltage ..... 220V  
Cord Length ..... 12 ft.  
Cord Gauge ..... 12 gauge  
Minimum Circuit Requirement..... 40A  
Included Plug ..... No  
Recommended Power Connection ..... Hardwired with Safety Lock-Out Switch

### Motor:

Type ..... TEFC Capacitor Start Induction  
Horsepower..... 4 HP  
Voltage ..... 220V  
Phase ..... Single Phase  
Amps ..... 32A  
Speed..... 3450 RPM  
Cycle ..... 60 Hz  
Number Of Speeds ..... 1  
Power Transfer ..... Direct Drive  
Bearings ..... Shielded and Permanently Sealed



**Main Specifications:**

**Operational Information**

Air Suction Capacity .....	3552 CFM
Max CFM (10" pipe) .....	3552 CFM @4.72 SP
Main Intake Diameter .....	10"
Number of Manifold Ports .....	4
Manifold Port Diameter.....	4"
Sound Level .....	90 dB @ 10 ft.

**Bag Information**

Number of Upper Bags .....	2
Upper Bag Dimensions .....	23 <sup>5</sup> / <sub>8</sub> " x 47 <sup>1</sup> / <sub>4</sub> "
Upper Bag Material .....	Woven Fabric
Upper Bag Filter Capacity .....	30 Micron Particles
Number of Collection Bags .....	2
Collection Bag Dimensions .....	23 <sup>5</sup> / <sub>8</sub> " x 47 <sup>1</sup> / <sub>4</sub> "
Collection Bag Material .....	Woven Fabric
Collection Bag Capacity .....	12 cu. ft. Each

**Impeller Information**

Type.....	Curve
Size.....	14 <sup>1</sup> / <sub>2</sub> "
Blade Thickness .....	1/4"

**Construction Information**

Stand .....	Pre-Formed Steel
Blower Housings .....	Formed Steel
Intake Manifold .....	Formed Steel
Impeller.....	Welded & Balanced Steel
Paint .....	Powder Coat

**Other Specifications**

ISO Factory .....	ISO 9001
Country of Origin .....	Taiwan
Warranty .....	1 Year
Serial Number Location.....	ID Label on Front of Machine
Assembly Time .....	1 Hour

**Features:**

- Four-Port Intake Manifold for Even Distribution to Collection Bags
- Upper Bag Filter Capacity to 30 Micron Particles
- Heavy-Duty Stand with 4" Casters and Brakes
- Sturdy Collection Bags with 24 cu. ft. Total Capacity



## MODEL G0671 4 HP DUST COLLECTOR

Performance Curve

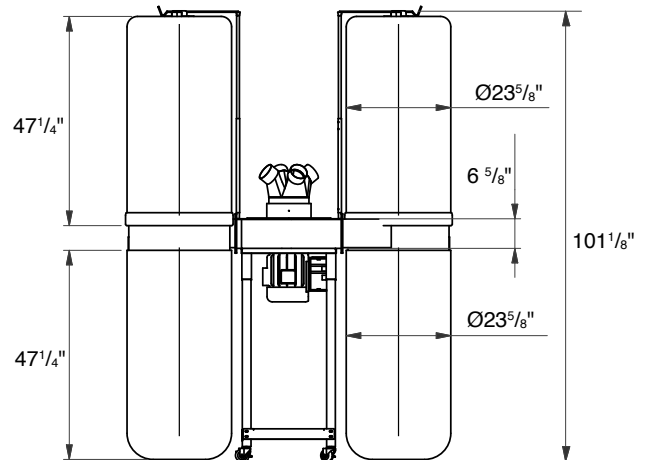
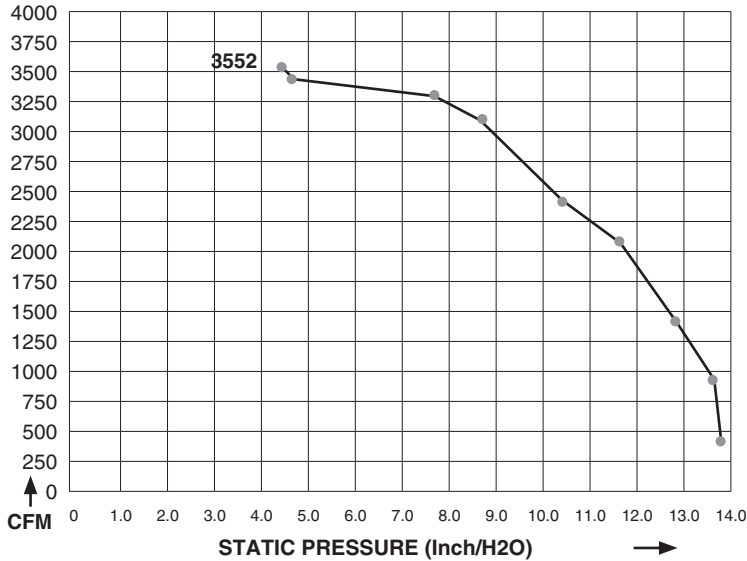

4 HP DUST COLLECTOR PERFORMANCE RESULTS					
Max CFM	Max SP	HP	Volts	Inlet	Impeller
3551.6	13.5	4 HP	220V	10"	14 1/2"

Inlet Dia. (inch)	10"	9"	8"	7"	6"	5"	4"	3"	2"
CFM	3551.6	3454.8	3282.6	2916.6	2475.4	2098.7	1452.9	979.4	484.3
Static Pressure (Inch/H2O)	4.72	4.82	6.98	8.5	10.3	11.1	12.53	13.2	13.5
Amps	30	29.5	27.5	24	21	16.8	12.5	11	8.6
Air Speed (m/s)	33	32.1	30.5	27.1	23	19.5	13.5	9.1	4.5

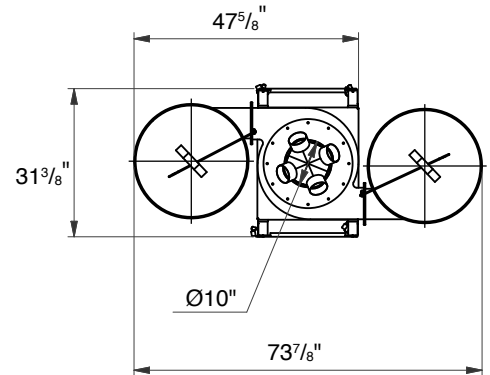

Test run using 30 micron upper and lower bag.







# MACHINE DATA SHEET

Customer Service #: (570) 546-9663 • To Order Call: (800) 523-4777 • Fax #: (800) 438-5901

## MODEL G0672 5 HP DUST COLLECTOR

### Product Dimensions:

Weight ..... 286 lbs.  
 Length/Width/Height ..... 73<sup>7</sup>/<sub>8</sub>" x 31<sup>3</sup>/<sub>8</sub>" x 134"  
 Foot Print (Length/Width)..... 73<sup>7</sup>/<sub>8</sub>" x 31<sup>3</sup>/<sub>8</sub>"

### Shipping Dimensions:

Type ..... Cardboard & Wood Frame  
 Content..... Machine  
 Weight..... 338 lbs.  
 Length/Width/Height..... 29" x 26" x 42"

### Electrical:

Switch..... ON/OFF Magnetic with Thermal Overload Protector  
 Switch Voltage ..... 220V  
 Cord Length ..... 12 ft.  
 Cord Gauge ..... 10 gauge  
 Minimum Circuit Requirement..... 50A  
 Included Plug ..... No  
 Recommended Power Connection ..... Hardwired with Safety Lock-Out Switch

### Motor:

Type ..... TEFC Capacitor Start Induction  
 Horsepower..... 5 HP  
 Voltage ..... 220V  
 Phase ..... Single Phase  
 Amps ..... 34A  
 Speed..... 3450 RPM  
 Cycle ..... 60 Hz  
 Number Of Speeds ..... 1  
 Power Transfer ..... Direct Drive  
 Bearings..... Shielded and Permanently Sealed



**Main Specifications:**

**Operational Information**

Air Suction Capacity .....	3961 CFM
Max CFM (10" Pipe).....	3961 CFM @5.36 SP
Main Intake Diameter .....	10"
Number of Manifold Ports .....	4
Manifold Port Diameter.....	4"
Sound Level .....	90 dB @ 10 ft.

**Bag Information**

Number of Upper Bags .....	2
Upper Bag Dimensions .....	23 <sup>5</sup> / <sub>8</sub> " x 70"
Upper Bag Material .....	Polyester Fabric
Upper Bag Filter Capacity .....	2.5 Micron Particles
Number of Collection Bags .....	2
Collection Bag Dimensions .....	23 <sup>5</sup> / <sub>8</sub> " x 57"
Collection Bag Material .....	Heavy-Duty Plastic
Collection Bag Capacity .....	12 cu. ft. Each

**Impeller Information**

Type.....	Curve
Size.....	15"
Blade Thickness .....	1/4"

**Construction Information**

Stand .....	Pre-Formed Steel
Blower Housings .....	Formed Steel
Intake Manifold .....	Formed Steel
Impeller.....	Welded & Balanced Steel
Paint .....	Powder Coat

**Other Specifications**

ISO Factory .....	ISO 9001
Country of Origin .....	Taiwan
Warranty .....	1 Year
Serial Number Location.....	ID Label on Front of Machine
Assembly Time .....	1 Hour

**Features:**

- Four-Port Intake Manifold for Even Distribution to Collection Bags
- Upper Bag Filter Capacity to 2.5 Micron Particles
- Heavy-Duty Stand with 4" Casters and Brakes
- Sturdy Collection Bags with 24 cu. ft. Total Capacity



## MODEL G0672 5 HP DUST COLLECTOR

### Performance Curve

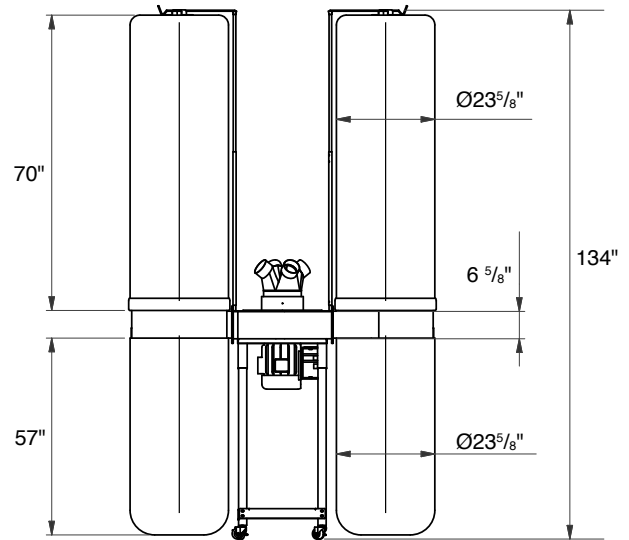
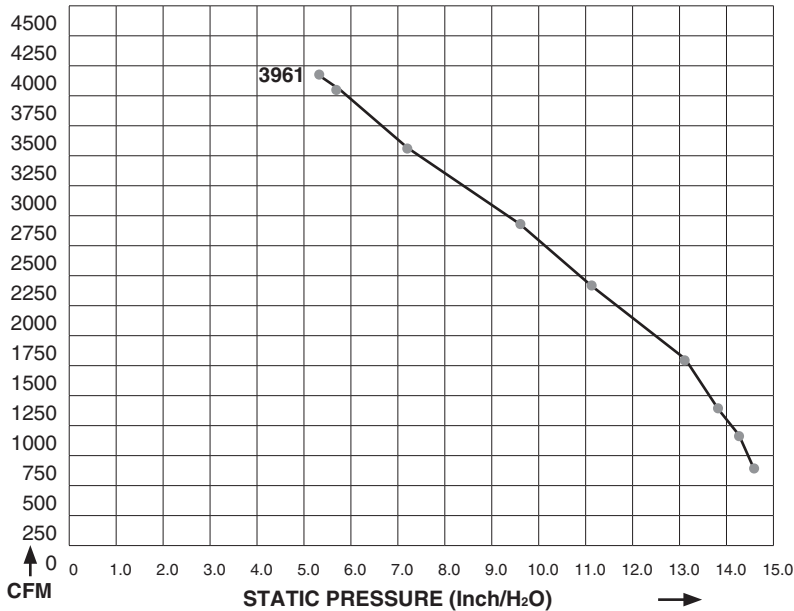

### 5 HP DUST COLLECTOR PERFORMANCE RESULTS

Max CFM	Max SP	HP	Volts	Inlet	Impeller
3960.6	14.6	5HP	220V	10"	15"

Inlet Dia. (inch)	10"	9"	8"	7"	6"	5"	4"	3"	2"
CFM	3960.6	3809.9	3336.4	2744.4	2206.3	1560.6	1140.8	861.0	656.5
Static Pressure (Inch/H <sub>2</sub> O)	5.36	5.6	7.2	9.64	11.4	13.04	13.84	14.08	14.6
Amps	33.2	32.5	30	25.5	21.7	17.4	13.5	10.7	9.5
Air Speed (m/s)	36.8	35.4	31	25.5	20.5	14.5	10.6	8	6.1

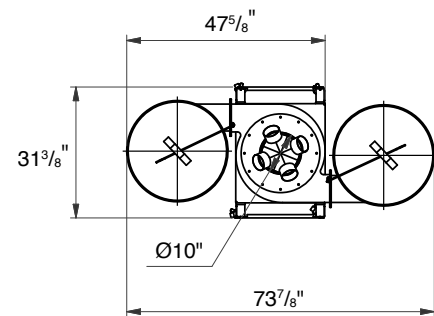

Test run using 2.5 micron upper bag and plastic lower collection bag.  
 Max amp draw after adding 10" x 4" x 4" inlet: 30.3A.



# MACHINE DATA SHEET

Customer Service #: (570) 546-9663 • To Order Call: (800) 523-4777 • Fax #: (800) 438-5901

## MODEL G0673 10 HP INDUSTRIAL DUST COLLECTOR

### Product Dimensions:

Weight ..... 410 lbs.  
 Length/Width/Height ..... 80<sup>3</sup>/<sub>8</sub>" x 80<sup>3</sup>/<sub>8</sub>" x 135<sup>1</sup>/<sub>2</sub>"  
 Foot Print (Length/Width)..... 80<sup>3</sup>/<sub>8</sub>" x 80<sup>3</sup>/<sub>8</sub>"

### Shipping Dimensions:

Type ..... Cardboard & Wood Frame  
 Content..... Machine  
 Weight ..... 506 lbs.  
 Length/Width/Height..... 47" x 53" x 31"

### Electrical:

Switch..... ON/OFF Magnetic with Thermal Overload Protector  
 Switch Voltage ..... 220V  
 Cord Length ..... 12 ft.  
 Cord Gauge ..... 10 gauge  
 Minimum Circuit Requirement..... 40A  
 Included Plug ..... No  
 Recommended Power Connection ..... Hardwired with Safety Lock-Out Switch  
 Conversion to 440V ..... G8296  
 Phase Converter ..... G7979

### Motor:

Type ..... TEFC Capacitor Start Induction  
 Horsepower..... 10 HP  
 Voltage ..... 220V/440V  
 Prewired..... 220V  
 Phase ..... 3 Phase  
 Amps ..... 30A/15A  
 Speed..... 3450 RPM  
 Cycle ..... 60 Hz  
 Number Of Speeds ..... 1  
 Power Transfer ..... Direct Drive  
 Bearings..... Shielded and Permanently Sealed



## Main Specifications:

### Operational Information

Air Suction Capacity .....	5360 CFM
Max CFM (10" Pipe).....	5360 CFM @ 10.08 SP
Main Intake Diameter .....	10"
Number of Manifold Ports .....	5
Manifold Port Diameter.....	4"
Sound Level .....	92.5 db @ 10ft.

### Bag Information

Number of Upper Bags .....	4
Upper Bag Dimensions .....	23 <sup>5</sup> / <sub>8</sub> " x 70"
Upper Bag Material .....	Woven Fabric
Upper Bag Filter Capacity .....	2.5 Micron Particles
Number of Collection Bags .....	4
Collection Bag Dimensions .....	23 <sup>5</sup> / <sub>8</sub> " x 57"
Collection Bag Material .....	Plastic
Collection Bag Capacity .....	12 cu. ft. Each

### Impeller Information

Type.....	Balanced Radial Fin
Size.....	17"
Blade Thickness .....	1/4"

### Construction Information

Stand .....	Pre-Formed Steel
Blower Housings .....	Formed Steel
Intake Manifold .....	Formed Steel
Impeller.....	Welded & Balanced Steel
Paint .....	Powder Coat

### Other Specifications

ISO Factory .....	ISO 9001
Country of Origin .....	Taiwan
Warranty .....	1 Year
Serial Number Location.....	ID Label on Front of Machine
Assembly Time.....	1 1/2 Hour

## Features:

- Five-Port Intake Manifold for Even Distribution to Collection Bags
- Upper Bag Filter Capacity to 2.5 Micron Particles
- Heavy-Duty Stand with 4" Casters and Brakes
- Sturdy Collection Bags with 48 cu. ft. Total Capacity



## MODEL G0673 10 HP DUST COLLECTOR

Performance Curve

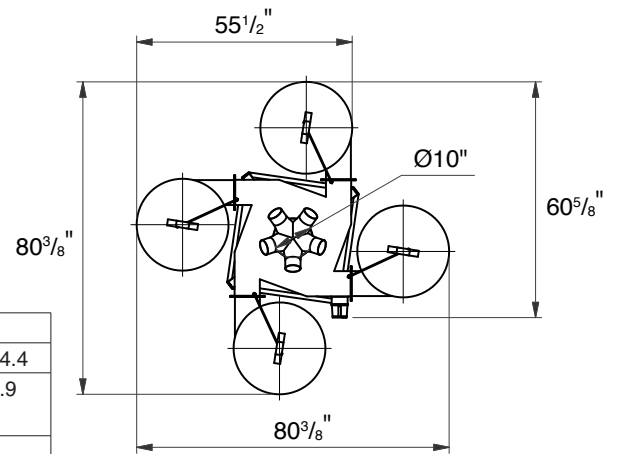
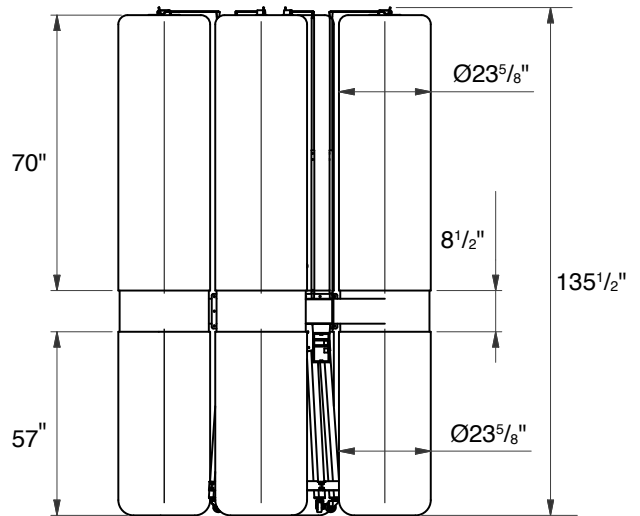
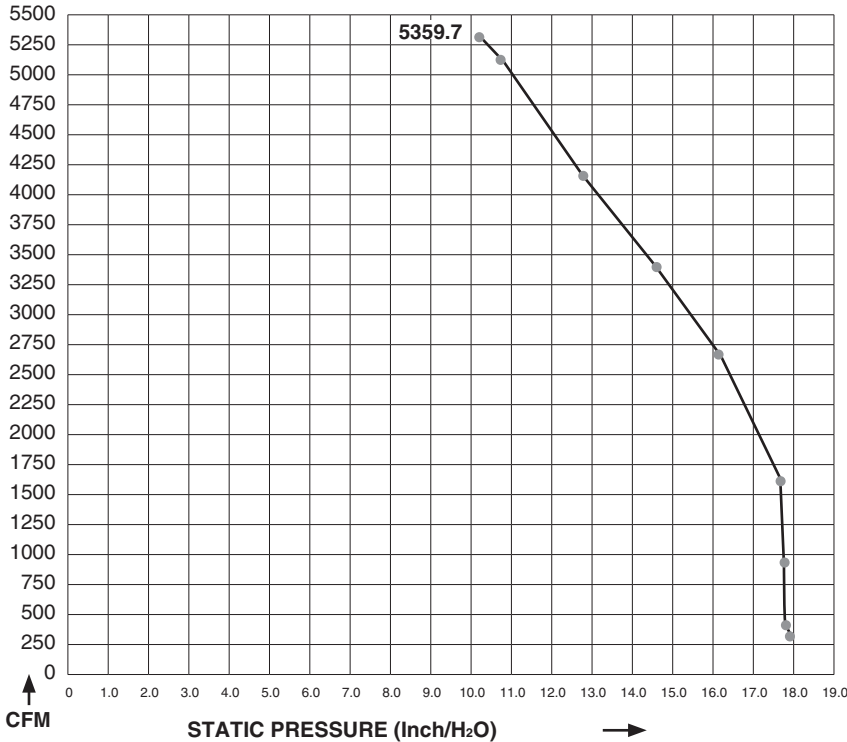

10 HP DUST COLLECTOR PERFORMANCE RESULTS					
Max CFM	Max SP	HP	Volts	Inlet	Impeller
5359.7	17.9	10HP	220V	10"	17"

Inlet Dia. (inch)	10"	9"	8"	7"	6"	5"	4"	3"	2"
CFM	5359.7	5176.8	4229.7	3390.2	2604.5	1678.9	968.6	430.5	344.4
Static Pressure (Inch/H <sub>2</sub> O)	10.08	10.64	12.96	14.72	16.08	17.68	17.72	17.8	17.9
Amps	32.6	32.1	30	26.6	23.1	18.7	15.4	13.1	12
Air Speed (m/s)	49.8	48.1	39.3	31.5	24.2	15.6	9	4	3.2

Test run using 2.5 micron upper bag and plastic lower collection bag.  
Max amp draw after adding 10" x 4" x 5 inlet: 30.5A.



# SECTION 1: SAFETY

## WARNING

### For Your Own Safety, Read Instruction Manual Before Operating this Machine

The purpose of safety symbols is to attract your attention to possible hazardous conditions. This manual uses a series of symbols and signal words intended to convey the level of importance of the safety messages. The progression of symbols is described below. Remember that safety messages by themselves do not eliminate danger and are not a substitute for proper accident prevention measures.



Indicates an imminently hazardous situation which, if not avoided, **WILL** result in death or serious injury.



Indicates a potentially hazardous situation which, if not avoided, **COULD** result in death or serious injury.



Indicates a potentially hazardous situation which, if not avoided, **MAY** result in minor or moderate injury. It may also be used to alert against unsafe practices.

### **NOTICE**

This symbol is used to alert the user to useful information about proper operation of the machine.

## WARNING

### Safety Instructions for Machinery

- 1. READ THE ENTIRE MANUAL BEFORE STARTING MACHINERY.** Machinery presents serious injury hazards to untrained users.
- 2. ALWAYS USE ANSI APPROVED SAFETY GLASSES WHEN OPERATING MACHINERY.** Everyday eyeglasses only have impact resistant lenses—they are NOT safety glasses.
- 3. ALWAYS WEAR A NIOSH APPROVED RESPIRATOR WHEN OPERATING MACHINERY THAT PRODUCES DUST.** Most types of dust (wood, metal, etc.) can cause severe respiratory illnesses.
- 4. ALWAYS USE HEARING PROTECTION WHEN OPERATING MACHINERY.** Machinery noise can cause permanent hearing loss.
- 5. WEAR PROPER APPAREL. DO NOT** wear loose clothing, gloves, neckties, rings, or jewelry that can catch in moving parts. Wear protective hair covering to contain long hair and wear non-slip footwear.
- 6. NEVER OPERATE MACHINERY WHEN TIRED OR UNDER THE INFLUENCE OF DRUGS OR ALCOHOL.** Be mentally alert at all times when running machinery.



# WARNING

## Safety Instructions for Machinery

7. **ONLY ALLOW TRAINED AND PROPERLY SUPERVISED PERSONNEL TO OPERATE MACHINERY.** Make sure operation instructions are safe and clearly understood.
8. **KEEP CHILDREN AND VISITORS AWAY.** Keep all children and visitors a safe distance from the work area.
9. **MAKE WORKSHOP CHILDPROOF.** Use padlocks, master switches, and remove start switch keys.
10. **NEVER LEAVE WHEN MACHINE IS RUNNING.** Turn power **OFF** and allow all moving parts to come to a complete stop before leaving machine unattended.
11. **DO NOT USE IN DANGEROUS ENVIRONMENTS.** DO NOT use machinery in damp, wet locations, or where any flammable or noxious fumes may exist.
12. **KEEP WORK AREA CLEAN AND WELL LIGHTED.** Clutter and dark shadows may cause accidents.
13. **USE A GROUNDED EXTENSION CORD RATED FOR THE MACHINE AMPERAGE.** Grounded cords minimize shock hazards. Undersized cords create excessive heat. Always replace damaged extension cords.
14. **ALWAYS DISCONNECT FROM POWER SOURCE BEFORE SERVICING MACHINERY.** Make sure switch is in OFF position before reconnecting.
15. **MAINTAIN MACHINERY WITH CARE.** Keep blades sharp and clean for best and safest performance. Follow instructions for lubricating and changing accessories.
16. **MAKE SURE GUARDS ARE IN PLACE AND WORK CORRECTLY BEFORE USING MACHINERY.**
17. **REMOVE ADJUSTING KEYS AND WRENCHES.** Make a habit of checking for keys and adjusting wrenches before turning machinery **ON**.
18. **CHECK FOR DAMAGED PARTS BEFORE USING MACHINERY.** Check for binding or misaligned parts, broken parts, loose bolts, and any other conditions that may impair machine operation. Repair or replace damaged parts before operation.
19. **USE RECOMMENDED ACCESSORIES.** Refer to the instruction manual for recommended accessories. Improper accessories increase risk of injury.
20. **DO NOT FORCE MACHINERY.** Work at the speed for which the machine or accessory was designed.
21. **SECURE WORKPIECE.** Use clamps or a vise to hold the workpiece when practical. A secured workpiece protects your hands and frees both hands to operate the machine.
22. **DO NOT OVERREACH.** Maintain stability and balance at all times.
23. **MANY MACHINES CAN EJECT WORKPIECES TOWARD OPERATOR.** Know and avoid conditions that cause the workpiece to "kickback."
24. **ALWAYS LOCK MOBILE BASES (IF USED) BEFORE OPERATING MACHINERY.**
25. **CERTAIN DUST MAY BE HAZARDOUS** to the respiratory systems of people and animals, especially fine dust. Be aware of the type of dust you are exposed to and always wear a respirator designed to filter that type of dust.





## **WARNING**

# Additional Safety for Dust Collectors

- 1. MACHINE USE.** This machine only is intended to collect wood dust/chips from woodworking machines. Do not use this dust collector as a vacuum. Do not use this dust collector with machines producing dust/chips from metal, asbestos products, lead paint, silica or any products that are not natural wood or man-made wood products such as plywood or particle board.
- 2. WEAR RESPIRATOR.** This machine may blow fine dust particles into the air during operation. Always wear an approved respirator during and for a short time after machine operation!
- 3. SUSPENDED DUST PARTICLES AND IGNITION SOURCES.** Do not operate the dust collector in areas where explosion risks would be high if dust were dispersed into the area. Areas of high risk include, but are not limited to, areas near pilot lights or open flames.
- 4. EMPTYING DUST.** When emptying dust from the collection bags or drum, wear a respirator and safety glasses. Empty dust into an approved container and dispose of properly.
- 5. SAFE SERVICING.** Disconnect power and allow impeller to completely stop before servicing or working on the dust collector or the ducting system, especially if clearing a clogged duct.
- 6. AVOIDING FIRES.** Do not allow steel to strike against the impeller—this may produce a spark. Sparks can smolder in wood dust for a long time before fire or flame is detected. If you accidentally collect metal during operation, immediately turn off the dust collector, unplug the power cord from the outlet or flip the disconnect switch and wait for all moving parts to stop. Remove collection bags and empty the dust into an approved air tight metal container. Prevent any chance of accidentally collecting metal again before resuming operations.
- 7. KEEPING FINGERS SAFE.** Do not place your hands or tools near the open inlet during operation for any reason. The powerful suction could cause accidental contact with the impeller which will cause serious personal injury or damage to the machine.
- 8. OPERATIONAL QUESTIONS.** If at any time you are experiencing difficulties performing the intended operation, stop using the machine! Then contact our Tech Support or ask a qualified expert how the operation should be performed.
- 9. DUST HAZARD.** Be aware that certain woods may cause an allergic reaction in people and animals, especially when exposed to fine dust. Make sure you know what type of wood dust you will be exposed to in case there is a possibility of an allergic reaction.

## **WARNING**

Like all machines there is danger associated with this machine. Accidents are frequently caused by lack of familiarity or failure to pay attention. Use this machine with respect and caution to lessen the possibility of operator injury. If normal safety precautions are overlooked or ignored, serious personal injury may occur.

## **CAUTION**

No list of safety guidelines can be complete. Every shop environment is different. Always consider safety first, as it applies to your individual working conditions. Use this and other machinery with caution and respect. Failure to do so could result in serious personal injury, damage to equipment, or poor work results.



# SECTION 2: CIRCUIT REQUIREMENTS

## Operation

### **!WARNING**

Serious personal injury could occur if you connect the machine to power before completing the setup process. **DO NOT** connect the machine to the power until instructed later in this manual.

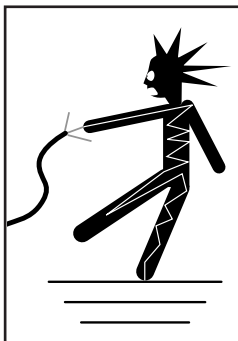

### **!WARNING**

Electrocution or fire could result if machine is not grounded and installed in compliance with electrical codes. Compliance **MUST** be verified by a qualified electrician!

### **NOTICE**

The Model G0671/G0672/G0673 is prewired for 220V operation. If you plan to use your Model G0673 at 440V, you **MUST** have a qualified electrician perform the 440V conversion described on this page.

### Full Load Amperage Draw

G0671 @ 220V.....	32 Amps
G0672 @ 220V.....	34 Amps
G0673 @ 220V.....	30 Amps
G0673 @ 440V.....	15 Amps

### Power Supply Circuit Requirements

You **MUST** connect your machine to a grounded circuit that is rated for the amperage given below. Never replace a circuit breaker on an existing circuit with one of higher amperage without consulting a qualified electrician to ensure compliance with wiring codes. **If you are unsure about the wiring codes in your area or you plan to connect your machine to a shared circuit, consult a qualified electrician.**

G0671 Minimum Circuit Size.....	40 Amps
G0672 Minimum Circuit Size.....	50 Amps
G0673 Minimum Circuit Size (220V) .....	40 Amps
G0673 Minimum Circuit Size (440V) .....	20 Amps

### Power Connection Device

We recommend having an electrician hardwire the machine (using a metal conduit setup) directly to a locking disconnect switch (**Figure 6**), which is directly connected to the power source.

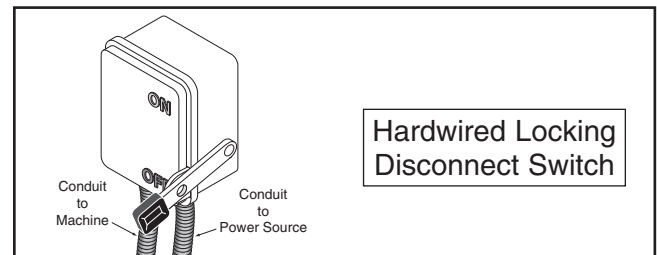

**Figure 6.** Hardwired locking disconnect switch.

### 440V Conversion

The Model G0673 can be converted for 440V operation. This conversion job consists of disconnecting the dust collector from the power source, changing the magnetic switch, and rewiring the motor for 440V operation, as shown on **Page 42**.

The necessary magnetic switch for this procedure can be purchased by calling Grizzly Customer Service at (800) 523-4777 and ordering Model G8296 (3-Phase 440V 10HP Mag Switch).

All wiring changes must be inspected by a qualified electrician before the dust collector is connected to the power source. If, at any time during this procedure you need help, call Grizzly Tech Support at (570) 546-9663.



# SECTION 3: SETUP

## Setup Safety

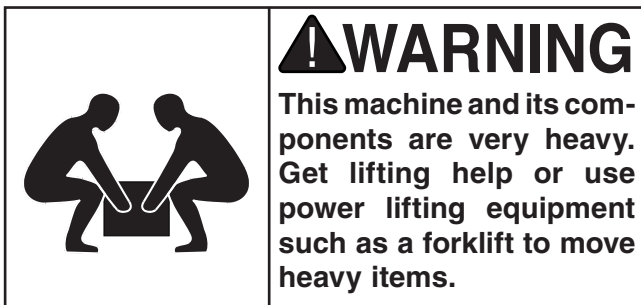
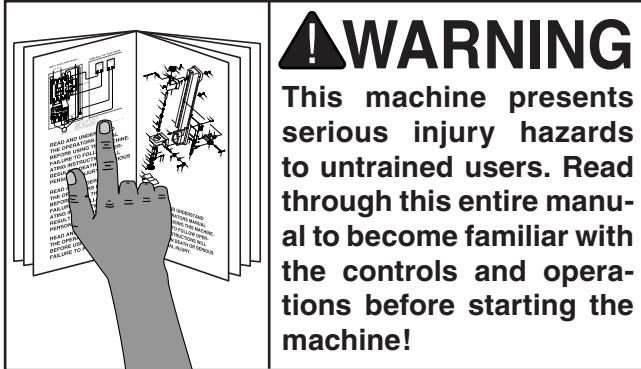

## Items Needed for Setup

The following items are needed to complete the setup process, but are not included with your machine:

Description	Qty
• Assistant.....	1 or more
• Safety Glasses (for each person).....	1
• Gloves (for each person).....	1
• Phillips Head Screwdriver.....	1
• Wrench 10mm.....	1
• Wrenches 12mm.....	2
• Ladder (for hanging upper bag).....	1

## Unpacking

Your machine was carefully packaged for safe transportation. Remove the packaging materials from around your machine and inspect it. If you discover the machine is damaged, *please immediately call Customer Service at (570) 546-9663 for advice.*

Save the containers and all packing materials for possible inspection by the carrier or its agent. *Otherwise, filing a freight claim can be difficult.*

When you are completely satisfied with the condition of your shipment, inventory the contents.



# G0671/G0672 Inventory

The following is a description of the main components shipped with your machine. Lay the components out to inventory them.

**Note:** If you can't find an item on this list, check the mounting location on the machine or examine the packaging materials carefully. Occasionally we pre-install certain components for shipping purposes.

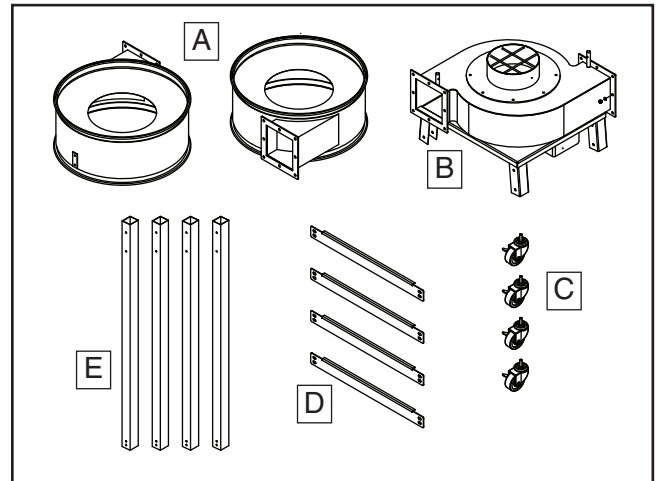

Figure 7. G0671/G0672 inventory 1.

Contents (Figures 7 & 8)	Qty
A. Collectors .....	2
B. Impeller Housing with Motor.....	1
C. Casters .....	4
D. Leg Braces .....	4
E. Legs.....	4
F. Gaskets .....	2
G. 4-in-1 Inlet Adapter.....	1
H. Hangers.....	2
I. Hanger Supports.....	2
J. Lower Collection Bags, G0671 (fabric).....	2
J. Lower Collection Bags, G0672 (plastic) .....	2
K. Upper Filter Bags (fabric) .....	2

Fasteners (where used) (not shown)	Qty
• Hex Bolts $\frac{5}{16}$ "-18 x $2\frac{1}{2}$ " (legs).....	8
• Hex Nuts $\frac{5}{16}$ "-18 (legs/collectors) .....	24
• Hex Bolts $\frac{5}{16}$ "-18 x $\frac{1}{2}$ " (leg braces).....	16
• Hex Bolts $\frac{5}{16}$ "-18 x 1" (collectors) .....	16
• Hex Bolts $\frac{1}{4}$ "-20 x $\frac{1}{2}$ " (hangers).....	6
• Flat Washers $\frac{5}{16}$ " (collectors) .....	32
• Phillips Head Screw 10-24 X $\frac{3}{8}$ " (inlet) .....	1
• Bag Clamps (bags).....	4

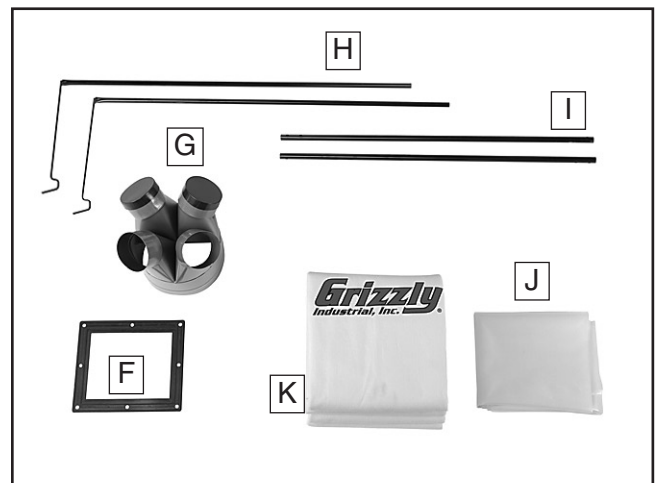

Figure 8. G0671/G0672 inventory 2.

If any nonproprietary parts are missing (e.g. a nut or a washer), we will gladly replace them; or for the sake of expediency, replacements can be obtained at your local hardware store.



# G0673 Inventory

The following is a description of the main components shipped with your machine. Lay the components out to inventory them.

**Note:** If you can't find an item on this list, check the mounting location on the machine or examine the packaging materials carefully. Occasionally we pre-install certain components for shipping purposes.

Contents (Figures 9–11)	Qty
A. Collectors .....	4
B. 5-in-1 Inlet Adapter .....	1
C. G0673 Impeller Housing with Motor.....	1
D. Legs.....	4
E. Leg Braces .....	4
F. Casters .....	4
G. Upper Filter Bags (fabric) .....	4
H. Lower Collection Bags (plastic).....	4
I. Hangers.....	4
J. Hanger Supports .....	4
K. Rubber Gaskets .....	4
L. Bag Clamps.....	8

Fasteners (where used) (not shown)	Qty
• Hex Bolts $\frac{5}{16}$ "-18 x $2\frac{1}{2}$ " (legs).....	8
• Hex Nuts $\frac{5}{16}$ "-18" (legs/collectors).....	40
• Hex Bolts $\frac{5}{16}$ "-18 x $\frac{1}{2}$ " (leg braces).....	16
• Hex Bolts $\frac{5}{16}$ "-18 x 1" (collectors).....	32
• Hex Bolts $\frac{1}{4}$ "-20 x $\frac{1}{2}$ " (hangers).....	12
• Flat Washers $\frac{5}{16}$ " (collectors).....	64
• Phillips Head Screw 10-24 X $\frac{3}{8}$ " (inlet).....	1

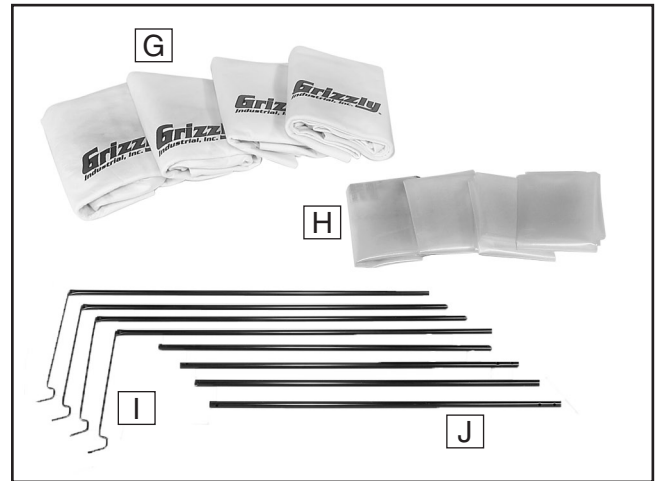

Figure 10. G0673 inventory 2.

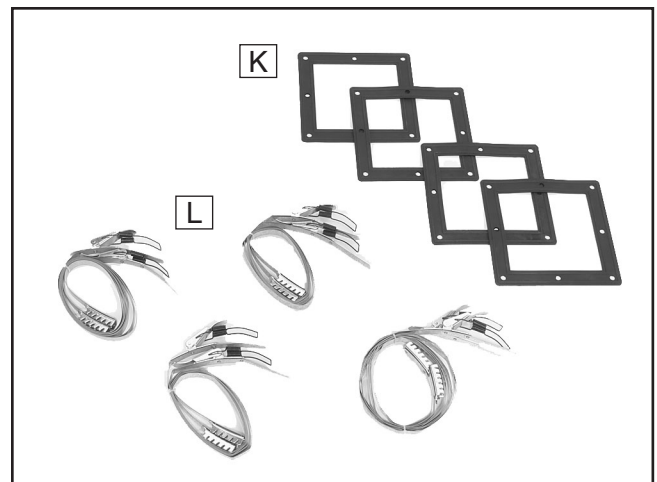

Figure 11. G0673 inventory 3.

If any nonproprietary parts are missing (e.g. a nut or a washer), we will gladly replace them; or for the sake of expediency, replacements can be obtained at your local hardware store.

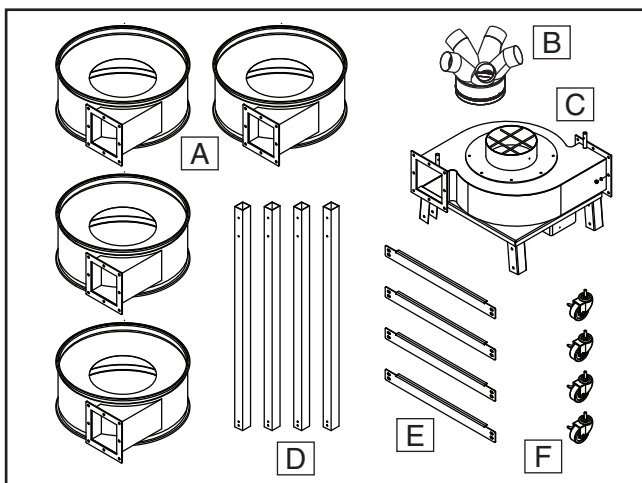







Figure 9. G0673 inventory 1.









# Hardware Recognition Chart

USE THIS CHART TO MATCH UP HARDWARE DURING THE ASSEMBLY PROCESS.

MEASURE BOLT DIAMETER BY PLACING INSIDE CIRCLE

-  #10
-  1/4"
-  5/16"
-  3/8"
-  7/16"
-  1/2"

-  Key
-  4mm
-  6mm
-  8mm
-  10mm
-  12mm
-  16mm

LINES ARE 1MM APART

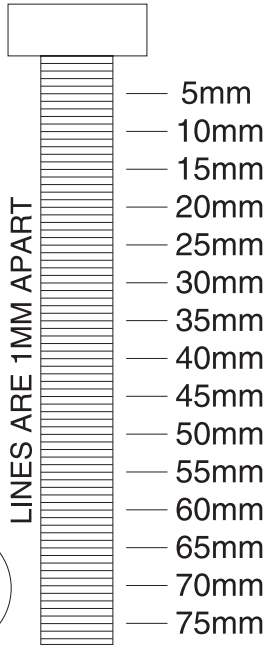

LINES ARE 1/16" INCH APART

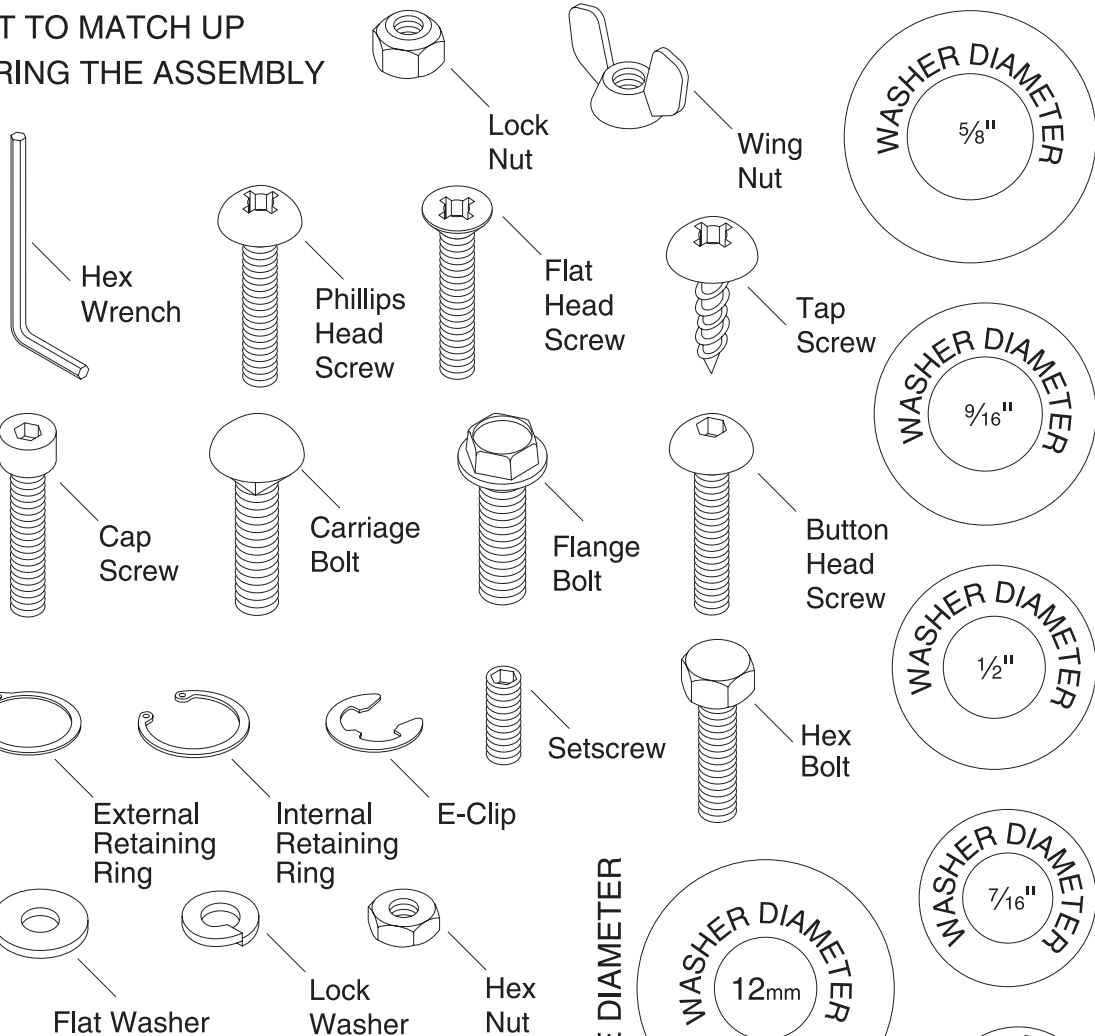
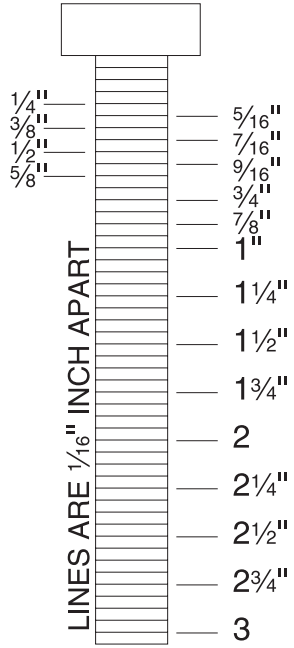

WASHERS ARE MEASURED BY THE INSIDE DIAMETER

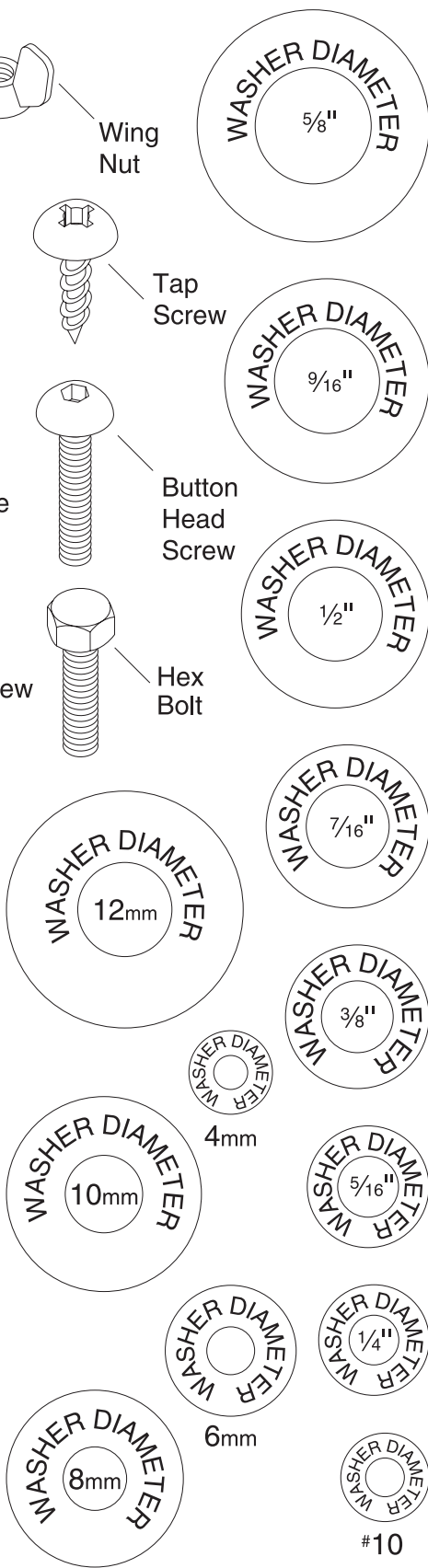



# Site Considerations

## Floor Load

Refer to the **Machine Data Sheet** for the weight and footprint specifications of your machine. Some residential floors may require additional reinforcement to support both the machine and operator.

## Placement Location

Consider existing and anticipated needs, size of material to be processed through each machine, and space for auxiliary stands, work tables or other machinery when establishing a location for your new machine. See **Figure 12** for the minimum working clearances.

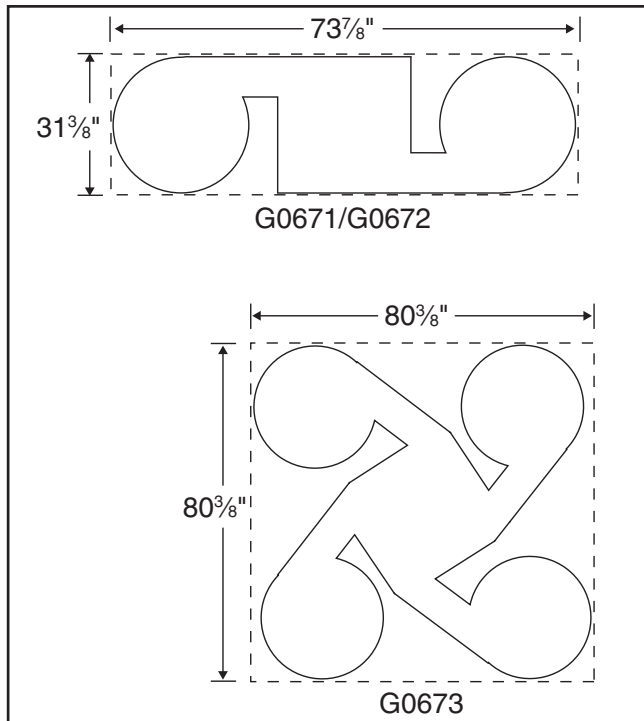

**Figure 12.** Model G0671-3 illustrated top view and suggested clearances.

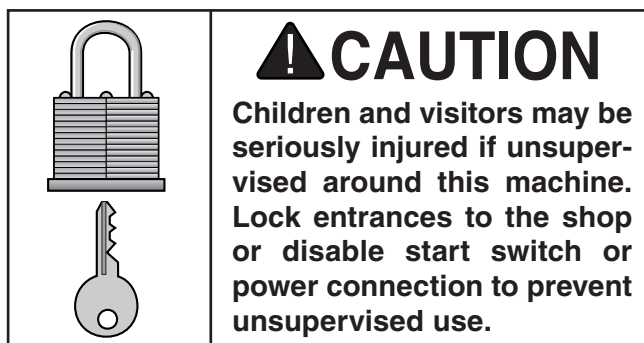

# Assembly

To assemble the dust collector:

1. With assistance, place the impeller housing on the floor so that the motor is pointing up.
2. Insert the legs into the leg mounting brackets and secure them with the eight  $\frac{5}{16}$ "-18 x 2 1/2" hex bolts and  $\frac{5}{16}$ "-18 hex nuts, as shown in **Figure 13**. Do not yet fully tighten the nuts.

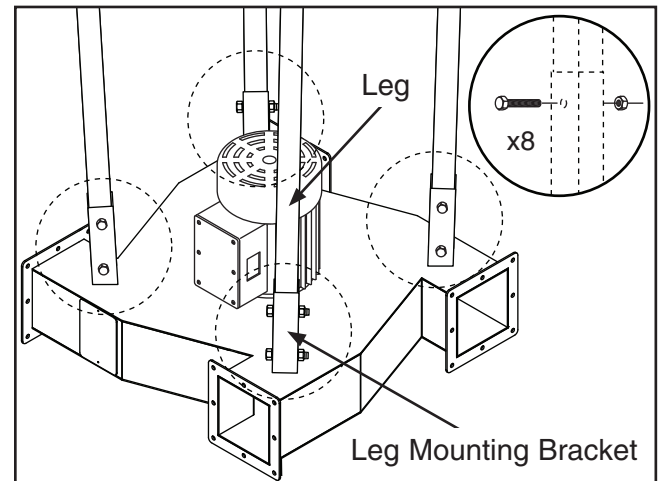

**Figure 13.** Attaching legs to impeller housing (Model G0673 shown).

3. Attach the four leg braces to the legs with the (16)  $\frac{5}{16}$ "-18 x 1/2" hex bolts, as shown in **Figure 14**. Fully tighten the bolts and the hardware from **Step 2**.

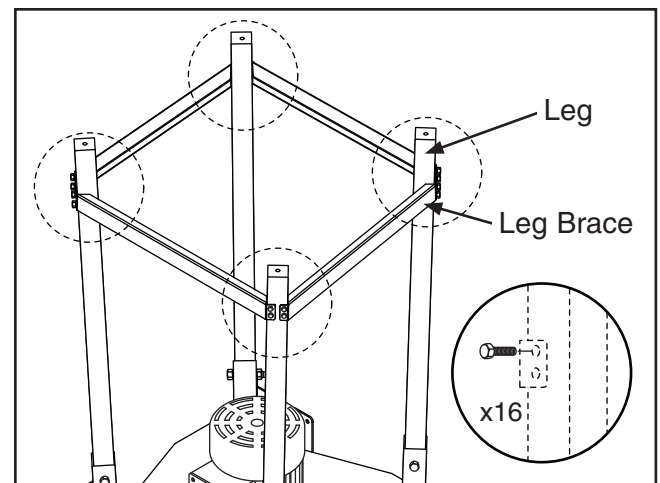

**Figure 14.** Attaching leg braces.

- Attach the four casters to the legs by threading them into the bottom of the legs, as shown in **Figure 15**.

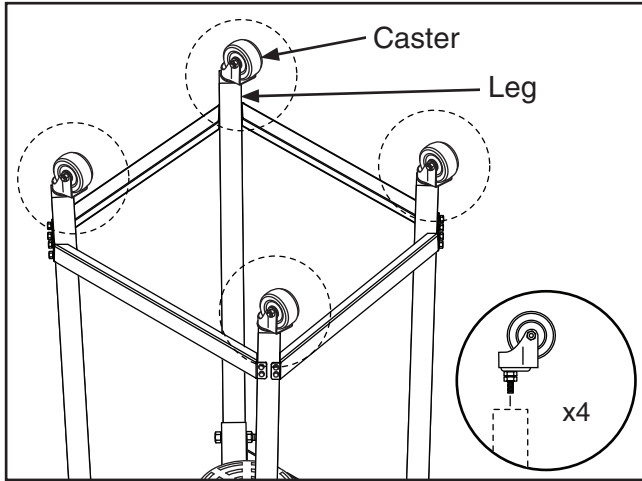

**Figure 15.** Attaching casters.

- With assistance, turn the entire assembly over so that the casters rest on the floor.
- Use eight  $\frac{5}{16}$ "-18 x 1" hex bolts, (16)  $\frac{5}{16}$ " flat washers, and eight  $\frac{5}{16}$ "-18 hex nuts to attach each collector to the impeller housing with a rubber gasket between the components, as shown in **Figure 16**.

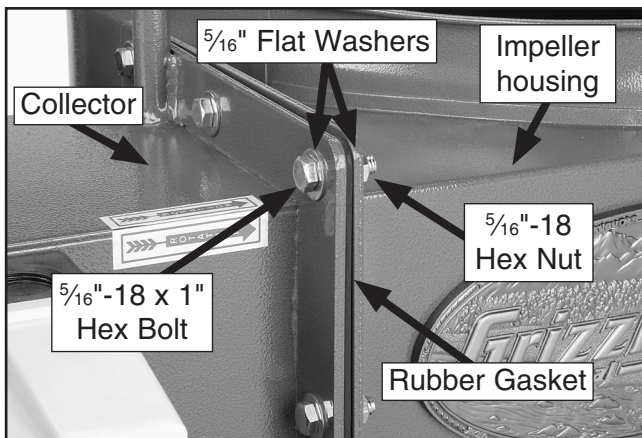
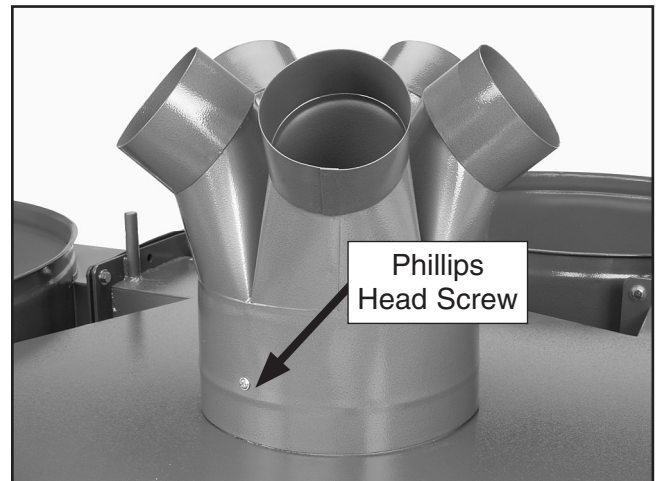

**Figure 16.** Collector mounted to impeller housing.

**Note:** The Model G0673 is a three-phase machine. If it is wired out of phase, the machine may not function properly. Proceed to **Test Run** on **Page 25** to determine if your machine is wired in phase, then proceed to **Step 7**.

The Models G0671 and G0672 are single phase and cannot be wired out of phase. For these models, continue below.

- Attach the inlet to the top of the impeller housing with the #10-24 x  $\frac{3}{8}$ " Phillips head screw, as shown in **Figure 17**.



**Figure 17.** Inlet mounted on impeller housing.



- Secure the hanger into the hanger support with one (Model G0673) or two (Model G0671/G0672)  $\frac{1}{4}$ "-20 x  $\frac{1}{2}$ " hex bolts (see **Figure 18**).

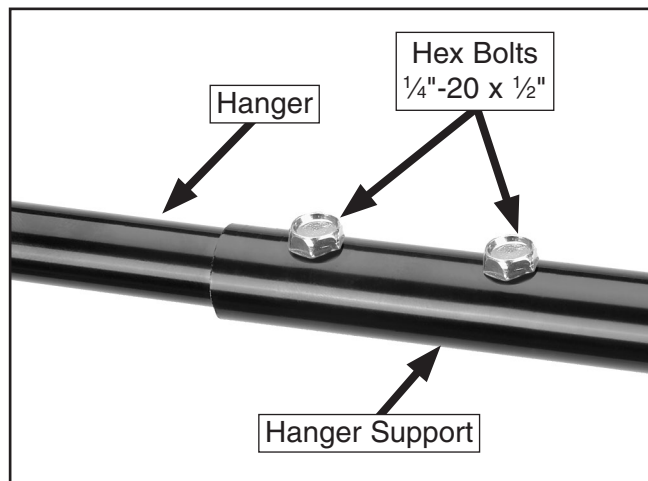

**Figure 18.** Hanger attached to hanger support (G061/G0672 shown).

- Mount the hanger assembly on the protruding rod on the collector with one (Model G0671/G0672) or two (Model G0673)  $\frac{1}{4}$ "-20 x  $\frac{1}{2}$ " hex bolts, as shown in **Figure 19**.

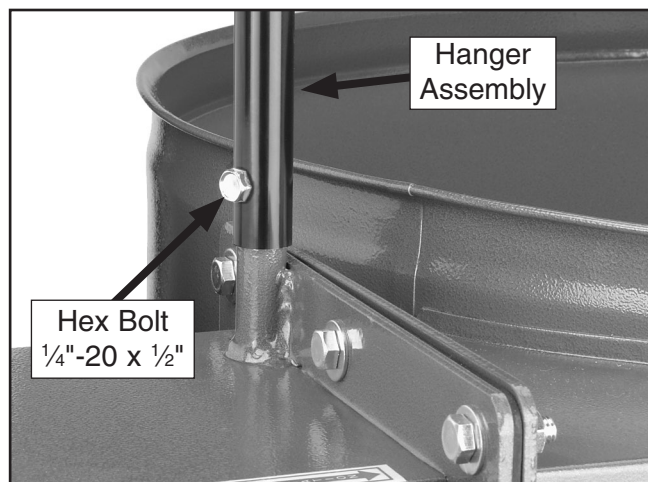

**Figure 19.** Hanger assembly mounted onto collector (G0671/G0672).

- Align the hanger assembly so that the hook is directly over the center of the collector.
- Repeat **Steps 8–10** for the remaining hanger assemblies.
- Place the loop at the top of each upper collection bag over each hook on the hanger assemblies (see **Figure 20**).

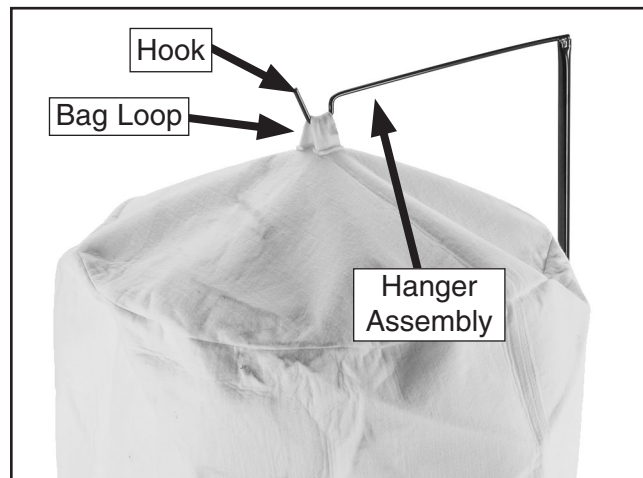

**Figure 20.** Upper filter bag mounted on hanger assembly.

- Thread the bag clamp into and around the bottom seam of the upper collection bag (see **Figure 21**).

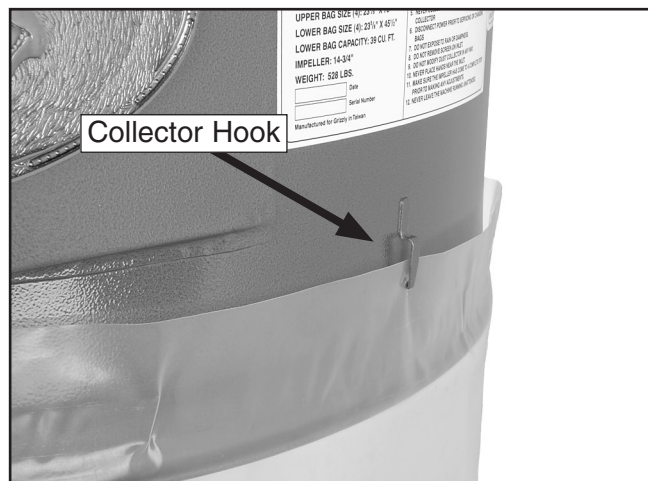

**Figure 21.** Upper filter bag secured to collector.

14. Slip the bottom of the bag with the clamp over the top lip of the collector.
15. Fasten the locking mechanism of the bag clamp to secure the bag to the collector (see **Figure 21**).
16. Repeat **Steps 12-15** for the remaining upper bags.
17. Install the lower bags.

—**Model G0671:** Repeat **Steps 13-15** in a similar manner to install the remaining lower collection bags on the lower rims of each collector. Then, proceed to **Test Run** on **Page 25**.

—**Model G0672-73:** Slip the lower plastic collection bag over the bottom lip of the collector and position the bag evenly around the collector. Snag the bag on the hooks to hold it in place until the bag clamp can be secured (see **Figure 22**).



**Figure 22.** Bottom collection bag snagged on collector hooks.

18. Wrap the bag clamp around the collector, position it between the bottom lip of the collector and the hooks, and fasten the bag clamp to secure the bag to the collector (see **Figure 23**).

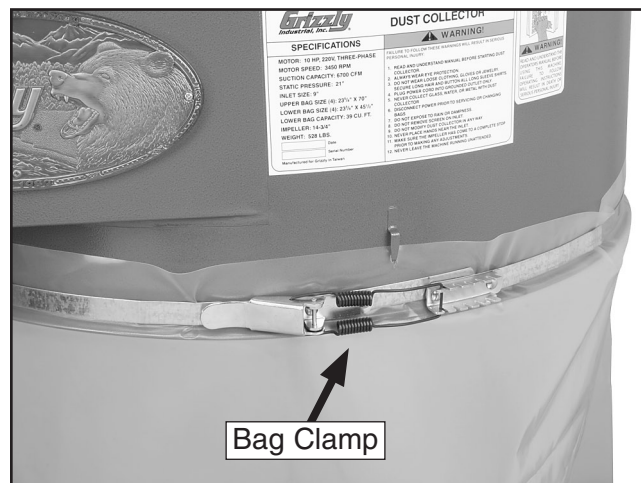

**Figure 23.** Lower collection bag secured to collector.

19. Repeat **Steps 17 & 18** for the remaining Model G0672-73 lower bag assemblies.

# Test Run

---

Once the assembly is complete, test run your machine to make sure it runs properly and is ready for regular operation.

The test run consists of verifying the following: 1) The motor powers up and runs correctly, and 2) (Model G0673 only), the motor turns the correct direction (machine is not wired out of phase).

If, during the test run, you cannot easily locate the source of an unusual noise or vibration, stop using the machine immediately, then review the **Troubleshooting** on **Page 38**.

If you still cannot remedy a problem, contact our Tech Support at (570) 546-9663 for assistance.

## **WARNING**

**Before starting the dust collector, make sure you have performed the preceding assembly instructions, and you have read through the rest of the manual and are familiar with the various functions and safety features on this machine. Failure to follow this warning could result in serious personal injury or even death!**

### To test run the machine:

1. Make sure you have read the safety instructions at the beginning of the manual and that the machine is setup properly.
2. Make sure all tools and objects used during setup are cleared away from the machine.
3. Connect the machine to the power source.
4. Turn the machine **ON** by pushing in the GREEN button on the power switch.
5. Listen to and watch for abnormal noises or actions. The machine should run smoothly with little or no vibration or rubbing noises.
  - Strange or unusual noises should be investigated and corrected before operating the machine further. Always disconnect the machine from power when investigating or correcting potential problems.
6. Turn the machine **OFF** by pushing in the RED button on the power switch.
7. **Model G0673 Only:** Verify that the power is not connected out of phase by starting/stopping the machine and determining if the motor turns in the correct direction, using the criteria below:
  - If the impeller turns counterclockwise (as looking down on the inlet port on the impeller housing), it is turning in the correct direction.
  - If the impeller turns counterclockwise, it is turning in the wrong direction. Stop the machine, shut off the power source, then swap any two of the three power wires that connect to the machine.



# SECTION 4: DESIGNING THE SYSTEM

## General

The Model G0671/G0672/G0673 can be operated as either a stationary or mobile unit. There are advantages and disadvantages to both set-ups. The advantage of the mobile system is eliminating the cost of many ducts and fittings. On the other hand, the stationary system is more versatile and convenient.

The Model G0671/G0672/G0673 is designed to be a central dust collector system. Locate the dust collector in an out of the way location such as a corner or separate room. These machines can accommodate the following number of machines each drawing 400 CFM on a 4" dust port:

<b>G0671:</b> .....	8
<b>G0672:</b> .....	9
<b>G0673:</b> .....	12

The large suction capacity of the Model G0671/G0672/G0673 allows great flexibility in planning and designing of your dust collection duct layout. Grizzly offers a complete line of dust collection accessories for setting up a stationary system. Additionally, Grizzly offers a complete guide book titled *Dust Collection Basics*.

A 4-port inlet is included with the Model G0671/G0672 and a 5-port inlet is included with the Model G0673 for quick and economical dust collection setup. However, depending upon your system design using this feature, bags may fill at different rates requiring you to empty some bags more often than others.

Whatever system you choose, always make sure there are no open flames (including pilot lights) in the same room as the dust collector; otherwise you risk an explosion if dust is dispersed into the air.

## Duct Material

You have many choices regarding main line and branch line duct material. For best results, use metal duct for the main line and branch lines, then use short lengths of flexible hose to connect each machine to the branch lines.

Plastic duct is also a popular material for home shops. However, be aware that there is a fire or explosion hazard if plastic duct material is used for dust collection without being grounded against static electrical charge build-up. This topic will be discussed later in this section. Another problem with using plastic is that it is less efficient per foot than metal.

### Metal Duct

Advantages of metal duct (**Figure 24**) is its conductivity and that it does not contribute to static electrical charge build-up. However, static charges are still produced when dust particles strike other dust particles as they move through the duct. Since metal duct is a conductor, it can be grounded quite easily to dissipate any static electrical charges.

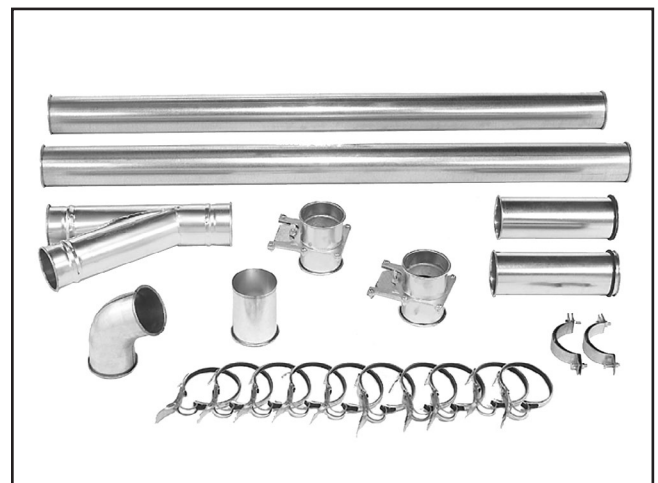

**Figure 24.** Examples of metal pipe and components.





There are quite a number of options when it comes to metal duct, but metal duct that is specially manufactured for dust collection is the best choice. When selecting your metal duct, choose high quality metal duct with smooth welded internal seams that will minimize airflow resistance. This type of duct usually connects to other ducts or elbows with a simple, self-sealing clamp, is very quick and easy to assemble, and can be readily dismantled and re-installed. This is especially important if you ever need to change things around in your shop or add more machines. See the **Accessories** section on **Page 35** for examples.

Avoid inferior metal duct that requires you to cut it to length and snap it together. This type of duct is time consuming to install because it requires you to seal all the seams with silicone and screw the components on the ends with sheet metal screws. Another disadvantage is the rough internal seams and crimped ends that unavoidably increase static pressure loss.

## Flexible Duct

Flexible hose is generally used for short runs, small shops and at rigid duct-to-tool connections. There are many different types of flex hose on the market today. These are manufactured from materials such as polyethylene, PVC, cloth hose dipped in rubber and even metal, including steel and aluminum.

The superior choice for flexible ducting is metal flex hose that is designed to be flexible and as smooth as possible to reduce static pressure loss.

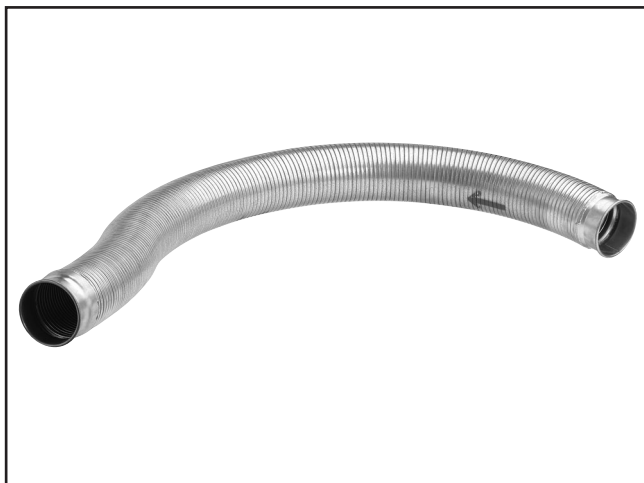

**Figure 25.** Example of flexible metal duct.

There are also many kinds of pure plastic flexible hose, such as non-perforated drainage type hose and dryer vent hose. Drainage type hose, while being economical, does not quite have the flexibility required for dust collection. The inside of the duct is also deeply corrugated and can increase the static pressure loss by as much as 50% over smooth wall duct. Dryer vent hose offers greater flexibility, but is non-resistant to abrasion and tends to collapse in a negative pressure system. We **DO NOT** recommend using dryer vent hose in your dust collection system.

If using flex-hose, choose one of the many types designed specifically for the movement of solid particles, i.e. dust, grains and plastics. However, the cost of specifically designed flexible duct can vary greatly. Grizzly offers polyethylene hose, which is well suited for the removal of particulate matter, especially sawdust, since it is durable and completely flexible. Polyethylene is also very economical and available in a wide variety of diameters and lengths for most applications.

## Plastic Duct

The popularity of plastic duct is due to the fact that it is economical and readily available. It is also simple to assemble and easily sealed against air loss. The primary disadvantage of plastic duct for dust collection is the inherent danger of static electrical build-up.



**Figure 26.** Example of plastic duct and components.

# System Design

## Step 1. Decide Who Will Design

For most small-to-medium sized shops, you can design and build the dust collection system yourself without hiring engineers or consultants. We have included some basic information here to get you started on a dust collection system design.

If you have a large shop or must design a complicated system, then we recommend that you perform additional research beyond this manual, or seek help from an expert.

## Step 2. Sketch Your Shop Layout

Planning is the most important step when designing a successful dust collection system.

Before you begin to draw your necessary layout sketch, we recommend that you visit our **FREE Workshop Planner** available on our website at [www.grizzly.com](http://www.grizzly.com).

Our *Workshop Planner* will allow you to quickly and easily draw and print a basic shop layout. Don't worry, non-Grizzly brand machines can be substituted with Grizzly machines for layout purposes. **Note:** After you're finished, make sure to save your layout for later modification.

Your sketch only needs the basic details of the shop layout, similar to **Figure 27**, including all your current/planned machines and your planned placement of the dust collector.

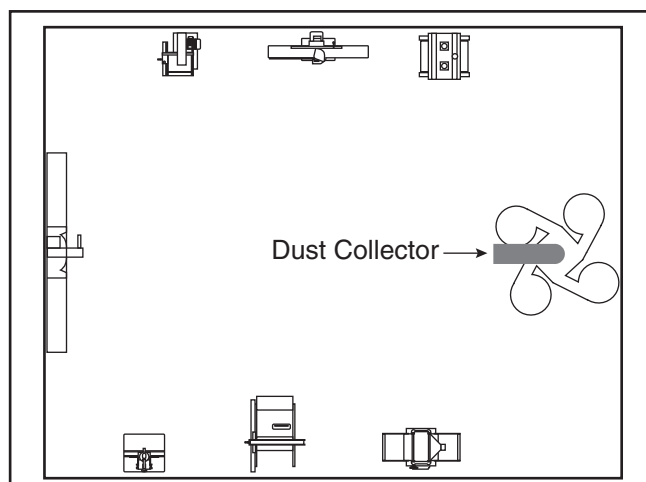
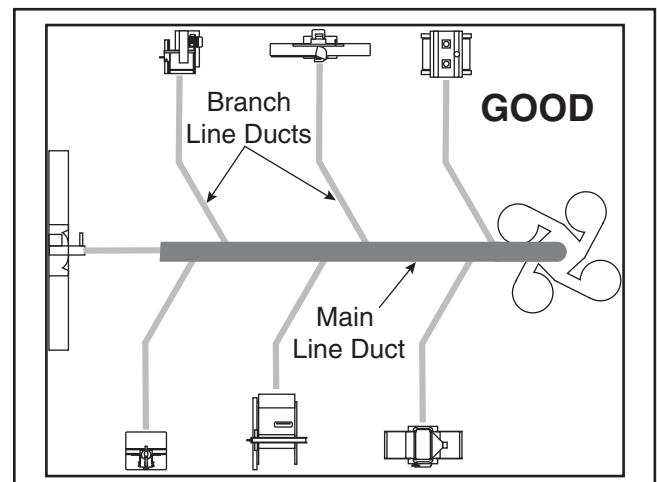

**Figure 27.** Initial sketch of shop layout.

## Step 3. Sketch a Basic Duct Layout

For the next step, sketch how your machines will connect to the dust collector. Consider these general guidelines for planning an efficient system:

1. Machines that produce the most sawdust should be placed nearest to the dust collector (i.e. planers and sanders).
2. Ideally, you should design the duct system to have the shortest possible main line and secondary branch ducts. See **Figures 28 & 29** for ideas of good duct layouts vs bad duct layouts.



**Figure 28.** Good duct layout.

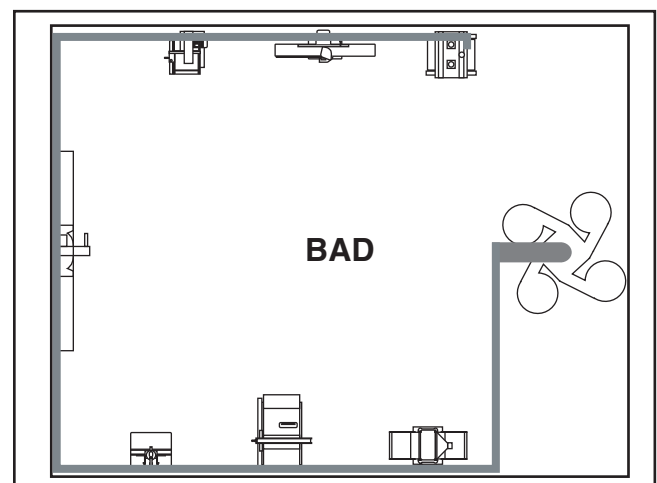

**Figure 29.** Bad duct layout.

3. Directional changes should be kept to a minimum. The more directional change fittings you use directly increases the overall resistance to airflow.
4. Gradual directional changes are more efficient than sudden directional changes (i.e. use the largest corner radius possible when changing hose or pipe direction).
5. Each branch line should have a blast gate immediately after the branch to control suction from one machine to another.
6. The simpler the system, the more efficient and less costly it will be.

### Step 4. Determine Required CFM of Each Machine

Since each machine produces a different amount of sawdust, the requirements for the minimum amount of CFM needed to move that sawdust is unique to the machine (for example, a planer produces more sawdust than a table saw). Knowing this required CFM is important in gauging which size of duct to use.

**Figure 30** will give you a close estimation of the airflow your machine requires. Machines that generate the most sawdust should be placed near the dust collector. If the machine has multiple dust ports, the total CFM required is the sum of all ports.

Machine Dust Port Size	Approximate Required CFM
2"	98
2.5"	150
3"	220
4"	395
5"	614
6"	884
7"	1203
8"	1570
9"	1990
10"	2456

**Figure 30.** Approximate required airflow for machines, based on dust port size.

If your machine does not have a built in dust port, use **Figure 31** to determine the size of dust port to install on your machine.

Machine	Average Dust Port Size
Table Saw.....	4"
Miter/Radial-Arm Saw.....	2"
Jointer (6" and smaller) .....	4"
Jointer (8"-12") .....	5"
Thickness Planer (13" and smaller).....	4"
Thickness Planer (14"-20") .....	6"
Shaper .....	4"
Router (mounted to table).....	2"
Bandsaw.....	4"
Lathe.....	4"
Disc Sander (12" and smaller).....	2"
Disc Sander (13-18").....	4"
Belt Sander (6" and smaller) .....	2"
Belt Sander (7"-9") .....	3"
Edge Sander (6" x 80" and smaller).....	4"
Edge Sander (6" x 80" and larger) .....	5"
Drum Sander (24" and smaller).....	2 x 4"
Drum Sander (24" and larger) .....	4 x 4"
Widebelt Sander (18" and smaller).....	5"
Widebelt Sander (24"-37" single head) ..	2 x 6"
Widebelt Sander (24" _51" double head) ..	.5 x 4"

**Figure 31.** Dust port size and quantity per average machine.

Write the required CFM for each machine on your sketch, as shown in **Figure 32**.

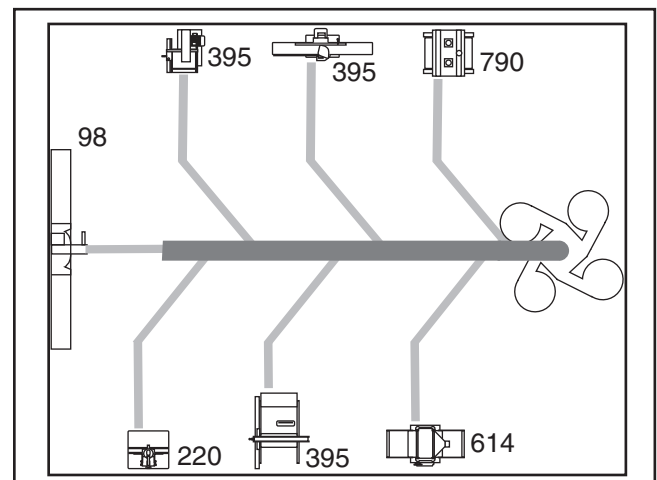

**Figure 32.** CFM requirements labeled for each machine.

## Determining Main Line Duct Size

The general rule of thumb for a main line duct is that the *velocity* of the airflow must not fall below 3500 FPM.

Use the inlet size of the dust collector as a starting point for the main line. Neck the main line down 1" for every 10' of length. This will usually keep the air velocity above 3500 FPM and, depending on your system, will allow you to keep multiple branches open at one time.

For the Model G0671/G0672/G0673 this is 10". Mark your drawing, as in **Figure 33**.

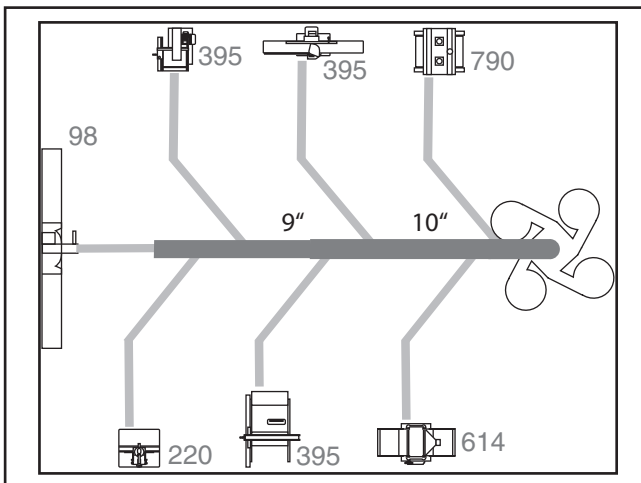

**Figure 33.** Main line size labeled on sketch.

## Determining Branch Line Duct Size

The general rule of thumb for a branch line duct is that the velocity of the airflow must not fall below 4000 FPM.

For small/medium sized shops, using the dust port size from the machine as the branch line duct size will achieve the correct velocity in most applications. However, if the dust port on the machine is smaller than 4", make the branch line 4" and reduce the line right before the dust port.

**Note:** *Systems with powerful dust collectors work better if multiple blast gates are left open. This also allows you to run two machines at once. Experiment with different combinations of blast gates open/closed to find the best results for your system.*

Write your determined branch line sizes on your drawing, as shown in **Figure 34**.

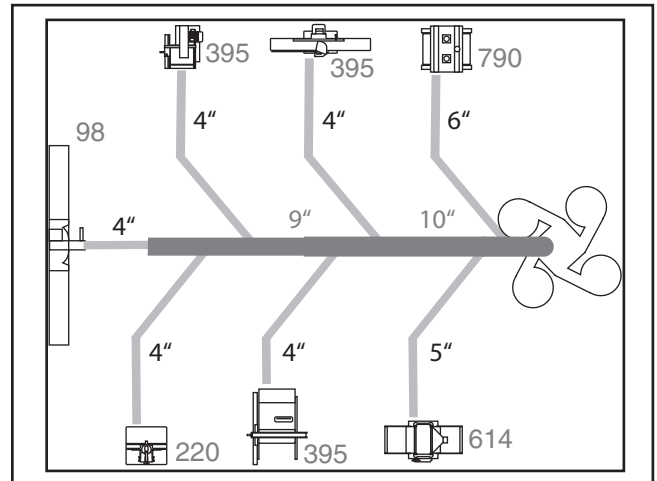

**Figure 34.** Branch line sizes labeled on sketch.

## Multiple Dust Ports

If your machine has multiple dust ports, add the total CFM given for each dust port size from **Figure 30**. Refer to **Figure 35** and find the CFM that is closest to your total to determine the correct branch size. Split the branch line just before the dust ports with matching duct sizes.

## Two Machines on Same Branch Line

If both machines will be running at the same time, add the total CFM given for each dust port size from **Figure 30**.

If both the machines will never be run at the same time, reference the machine with biggest dust port to **Figure 35** and add blast gates after the Y-branch to open/close the line to each machine.

Total CFM	Branch Line Size
<500	4"
600	5"
700	5"
800	6"
1000	6"
1200	7"
1400	8"
1600	8"

**Figure 35.** Branch line sizing chart by total CFM (for use when multiple machines share line).



## Calculating Duct Resistance

Adding duct work, elbows, branches and any other components to a duct line increases airflow resistance (static pressure loss). This resistance can be minimized by using rigid (smooth) pipe and gradual curves, as opposed to flexible pipe and 90° elbows.

To help you think about this resistance, imagine riding a bicycle in a tunnel that is an exact replica of your duct work. If the inside of the tunnel is very bumpy (flexible pipe) and has many sharp turns (90° elbows), it will take a lot more effort for you to travel from one end to the other than if your path is smooth and straight.

The purpose of calculating this resistance is to determine if it is low enough from the machine to the dust collector to meet the given requirement for the machine. Use the charts in **Figure 36** to calculate the resistance of duct work.

Duct Dia.	Approximate Static Pressure Loss Per Foot of Rigid Pipe		Approximate Static Pressure Loss Per Foot of Flex Pipe	
	Main Lines at 3500 FPM	Branch Lines at 4000 FPM	Main Lines at 3500 FPM	Branch Lines at 4000 FPM
2"	0.091	0.122	0.35	0.453
2.5"	0.08	0.107	0.306	0.397
3"	0.071	0.094	0.271	0.352
4"	0.057	0.075	0.215	0.28
5"	0.046	0.059	0.172	0.225
6"	0.037	0.047	0.136	0.18
7"	0.029	0.036	0.106	0.141
8"	0.023	0.027	0.08	0.108
9"	0.017	0.019	0.057	0.079

Fitting Dia.	90° Elbow	45° Elbow	45° Wye(Y)	90° Wye(Y)
3"	0.47	0.235	0.282	0.188
4"	0.45	0.225	0.375	0.225
5"	0.531	0.266	0.354	0.236
6"	0.564	0.282	0.329	0.235
7"	0.468	0.234	0.324	0.216
8"	0.405	0.203	0.297	0.189

**Figure 36.** Static pressure loss charts.

In most small/medium shops it is only necessary to calculate FPM for the line (from the dust collector to the machine) with the longest duct length or the most fittings (operating under the assumption that if the line with the highest resistance works, the others will be fine).

The line with the longest duct length and most fittings in our system sketch (see **Figure 34**) is the one connected to the router table, which draws 220 CFM.

**To calculate the static pressure loss of any given line in the system, follow these steps:**

1. Make a list of each size duct in the line, including the length, and multiply those numbers by the static pressure loss value given in **Figure 36**.
2. List each type of elbow or branch and multiply the quantity (if more than one) by the static pressure loss given in **Figure 36**.
3. Add the additional factors from **Figure 37** to your list.

Additional Factors	Static Pressure Loss
Seasoned (well used) Dust Collection Filter	1
Entry Loss at Large Machine Hood	2

**Figure 37.** Additional factors affecting static pressure loss.

*Continued on next page* →



4. Total your list, as shown in the example in **Figure 38**, to come up with your overall static pressure loss number for that line.

**Note:** Always account for a seasoned filter, so you don't end up with a system that only works right when the filter is clean.

<b>Main Line</b>		
6" Rigid Pipe (.037) at 20'	.....	0.740
<b>Branch Line</b>		
4" Rigid Pipe (.075) at 10'	.....	0.750
4" Flex Pipe (.28) at 5'	.....	1.400
<b>Elbows/Branches</b>		
6" 45° Y-Branch	.....	0.329
4" 45° Elbow	.....	0.225
<b>Additional Factors</b>		
Seasoned Filter	.....	<u>1.000</u>
<b>Total Static Pressure Loss</b>	.....	<b>4.444</b>

**Figure 38.** Example list for totaling SP loss.

**Note:** When calculating static pressure loss to determine if multiple lines can be left open at the same time, only include the main line numbers once.

5. Compare the total static pressure loss for that line to the closest CFM given in the **Performance Curve** section on the **Machine Data Sheet** (located toward the front of this manual).

**Example:** go to the Model G0671 Data Sheet *Performance Curve* section (see **Page 4**) or see **Figure 39** and find 4.4 on the Pressure axis, then go up the CFM axis to the closest value—approximately 3550 CFM, as shown in **Figure 39**.

The 3550 CFM (**Figure 39**) for the static pressure loss of the line connected to the router is well above the 220 CFM requirement of that machine.

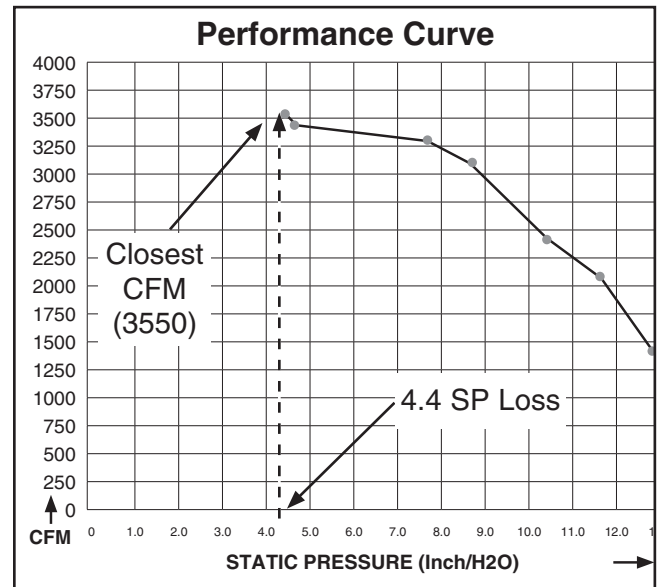

**Figure 39.** CFM for static pressure loss of line connected to G0671 dust collector & router.

—If the CFM for your static pressure loss is above the requirement of the machine connected to the end of that branch line, then dust collection will most likely be successful. Congratulations! You've just designed your own dust system. Refer to the **Accessories** section on **Page 35** to start buying the components necessary to make your system a reality.

—If the CFM for your static pressure loss is below the requirement of the machine, then that line will not effectively collect the dust. You must then modify some of the factors in that line to reduce the static pressure loss. Some of the ways to do this include: 1) Installing larger duct, 2) reducing amount of flexible duct used, 3) increasing machine dust port size, 4) moving machine closer to dust collector to eliminate duct length, and 5) reducing 90° elbows or replacing them with 45° elbows



# System Grounding

Since plastic hose is abundant, relatively inexpensive, easily assembled and air tight, it is a very popular material for conveying dust from woodworking machines to the dust collector. We recommend using flexible hose (flex-hose) to connect the woodworking machine to the dust collection system. However, plastic flex-hose and plastic duct are insulators, and dust particles moving against the walls of the plastic duct create static electrical build up. This charge will build until it discharges to a ground. If a grounding medium is not available to prevent static electrical build up, the electrical charge will arc to the nearest grounded source. This electrical discharge may cause an explosion and subsequent fire inside the system.

To protect against static electrical build up inside a non-conducting duct, a bare copper wire should be placed inside the duct along its length and grounded to the dust collector. You must also confirm that the dust collector is continuously grounded through the electrical circuit to the electric service panel.

If you connect the dust collector to more than one machine by way of a non-conducting branching duct system and blast gates, the system must still be grounded as mentioned above. We recommend inserting a continuous bare copper ground wire inside the entire duct system and attaching the wire to each grounded woodworking machine and dust collector.

Be sure that you extend the bare copper wire down all branches of the system. Do not forget to connect the wires to each other with wire nuts when two branches meet at a "Y" or "T" connection.

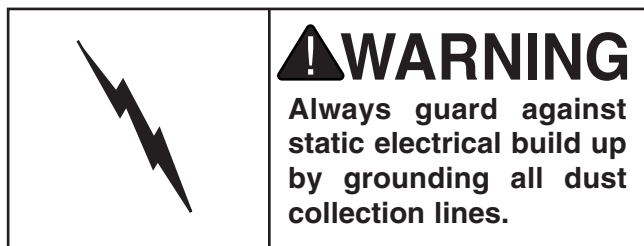

Ensure that the entire system is grounded. If using plastic blast gates to direct air flow, the grounding wire must be jumped (**Figure 40**) around the blast gate without interruption to the grounding system.

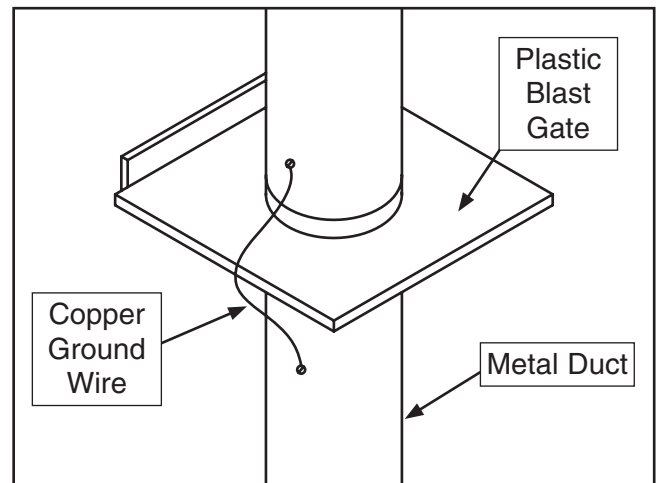

**Figure 40.** Ground jumper wire when using plastic blast gates and metal duct.

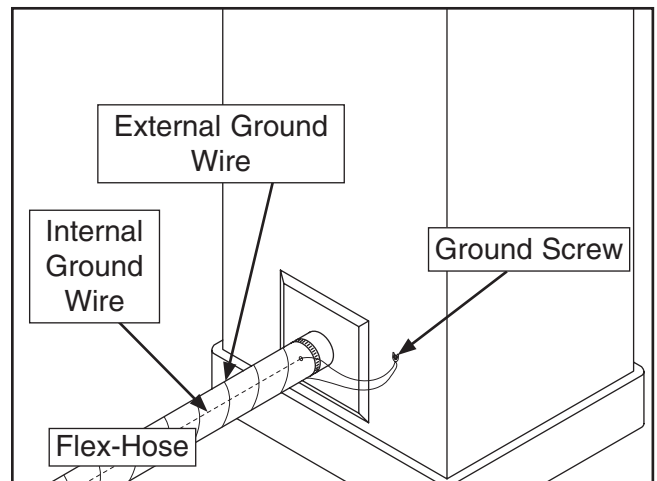

**Figure 41.** Flex-hose grounded to machine.

We also recommend wrapping the outside of all plastic ducts with bare copper wire to ground the outside of the system against static electrical build up. Wire connections at Y's and T's should be made with wire nuts.

Attach the bare ground wire to each stationary woodworking machine and attach to the dust collector frame with a ground screw, as shown in **Figure 41**. Ensure that each machine is continuously grounded to the grounding terminal in your electric service panel.

# SECTION 5: OPERATIONS

## Operation Safety

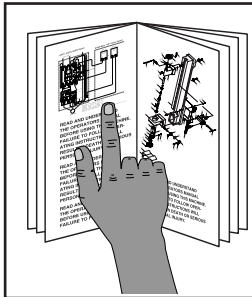

### **!WARNING**

To reduce the risk of serious injury when using this machine, read and understand this entire manual before beginning any operations.

### **!WARNING**

Damage to your eyes, lungs, and ears could result from using this machine without proper protective gear. Always wear safety glasses, a respirator, and hearing protection when operating this machine.

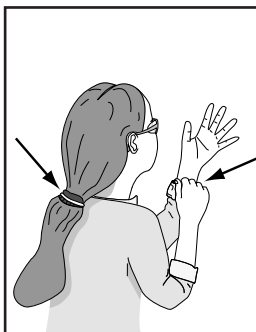
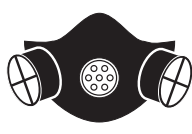

### **!WARNING**

Loose hair, clothing, or jewelry could get caught in machinery and cause serious personal injury. Keep these items away from moving parts at all times to reduce this risk.

### **NOTICE**

If you have never used this type of machine or equipment before, WE STRONGLY RECOMMEND that you read books, trade magazines, or get formal training before beginning any projects. Regardless of the content in this section, Grizzly Industrial will not be held liable for accidents caused by lack of training.

## Basic Controls

This section covers the basic controls used during routine operations:

**ON Button:** Starts the motor.

**OFF Button:** Stops the motor.

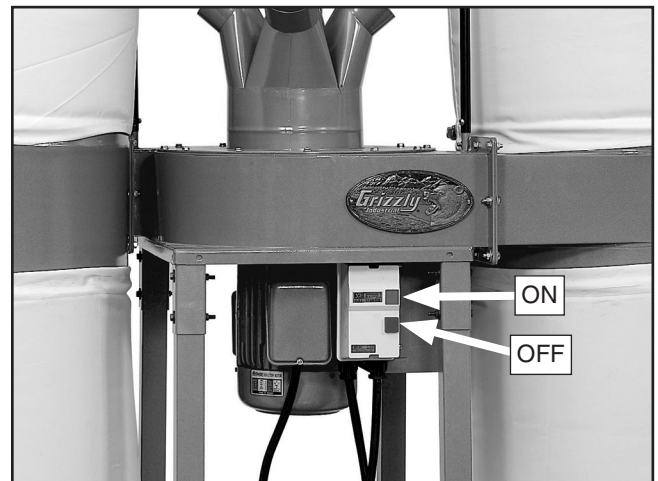

Figure 42. ON/OFF button locations.

## General

Operating your Model G0671/G0672/G0673 is simple and straightforward. Blast gates located at each of the woodworking machines control the airflow from the woodworking machine to the dust collector. If a machine is not being used, keep the blast gate closed to maintain higher levels of efficiency throughout the system.

### **!CAUTION**

DO NOT use the dust collector for any other purpose besides collecting dust from connected woodworking machines. A dust collector should NEVER be used as a shop vacuum. For safest use, wear a respirator and use an air cleaner in addition to the dust collector.





# SECTION 6: ACCESSORIES

## H5293—4" Metal Duct Starter Kit

## H5295—5" Metal Duct Starter Kit

## H5297—6" Metal Duct Starter Kit

Save over 20% with this great starter kit. Includes: (2) machine adapters, (10) pipe clamps, (3) 5' straight pipes, (1) branch, (3) pipe hangers, (1) end cap, (3) adjustable nipples, (1) 90° elbow, and (1) 60° elbow.

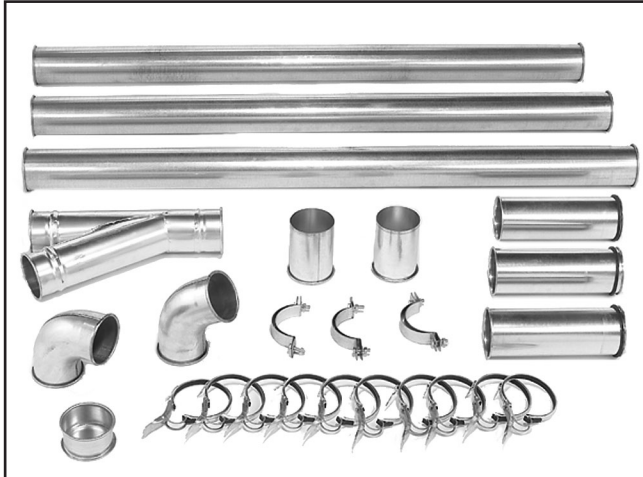

Figure 43. Metal Duct Starter Kit.

## H5294—4" Metal Duct Machine Addition Kit

## H5296—5" Metal Duct Machine Addition Kit

## H5298—6" Metal Duct Machine Addition Kit

Save over 20% with this great machine addition kit. Includes: (2) blast gates, (1) machine adapter, (10) pipe clamps, (2) pipe hangers, (2) 5' straight pipes, (2) adjustable nipples, (1) branch, and (1) 60° elbow.

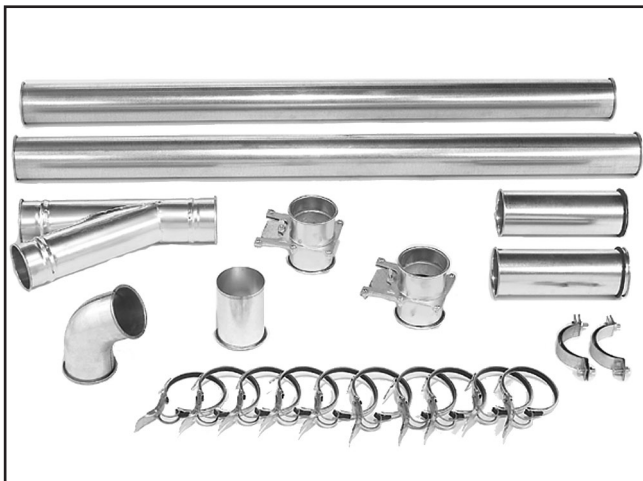

Figure 44. Metal Duct Machine Addition Kit.

**Call 1-800-523-4777 To Order**

G0671/G0672/G0673 Dust Collector

## G6162—4" x 5' Straight Metal Pipe

## G7346—5" x 5' Straight Metal Pipe

## G7364—6" x 5' Straight Metal Pipe

## H5227—7" x 5' Straight Metal Pipe

## H5237—8" x 5' Straight Metal Pipe

## H5252—9" x 5' Straight Metal Pipe

These laser welded straight pipes ensure a super smooth internal seam. Ends easily clamp together for a sealed fit without screws or silicone.

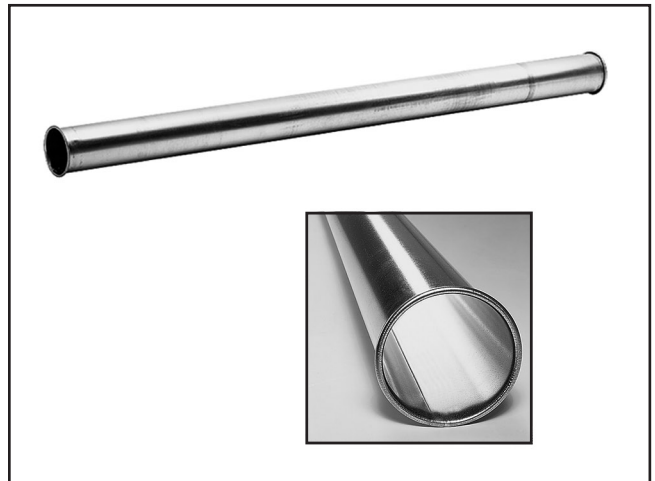

Figure 45. Straight Metal Pipe.

## H7216—5" x 5' Rigid Metal Flex Hose

## H7217—6" x 5' Rigid Metal Flex Hose

## H7218—7" x 5' Rigid Metal Flex Hose

## H7219—8" x 5' Rigid Metal Flex Hose

## H7220—9" x 5' Rigid Metal Flex Hose

This flex hose provides just enough flexibility to make difficult connections while still keeping the inside wall as smooth as possible to minimize static pressure loss.

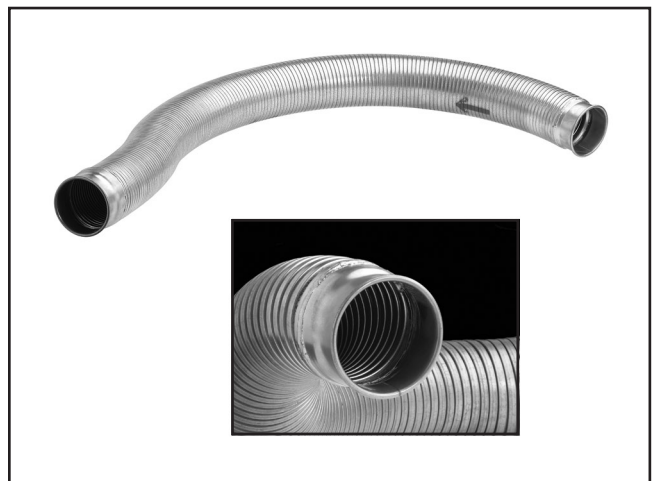

Figure 46. Rigid Metal Flex Hose.



### Metal Elbows

These industrial metal elbows are available from 4"–8" with 90°, 60°, 45°, or 30° curves. Also, available with a 90° long radius curve. Call (800) 523-4777 or visit [www.grizzly.com](http://www.grizzly.com) for more information and pricing.

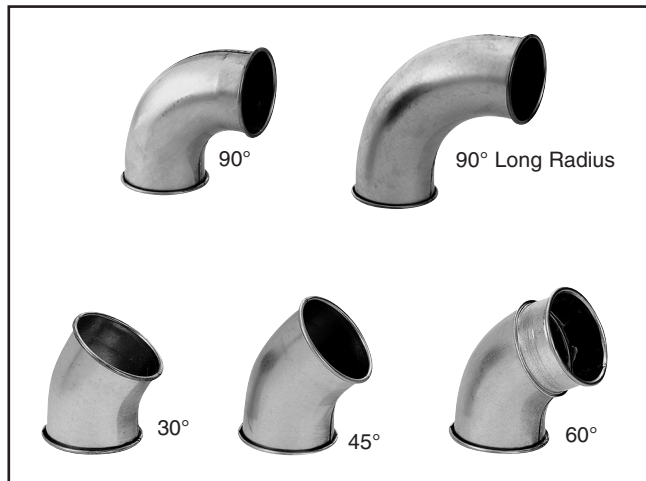

Figure 47. Metal elbow examples.

- G6177—4" Metal Blast Gate
- G7340—5" Metal Blast Gate
- G7358—6" Metal Blast Gate
- H5234—7" Metal Blast Gate
- H5249—8" Metal Blast Gate
- H5259—9" Metal Blast Gate



Figure 48. Metal Blast Gate.

G8296—Mag Switch 3-Phase 440V for Model G0673 Conversion

Call 1-800-523-4777 To Order

### Metal Branches

We carry many different branches, all designed to minimize airflow resistance.

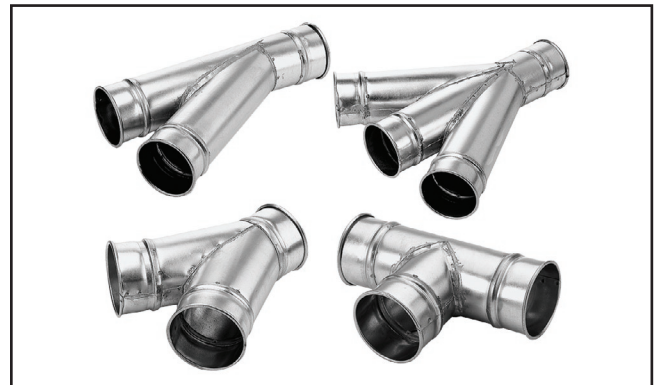

Figure 49. Metal Branches.

### Reducers & Adapters

We carry a multitude of reducers and elbows to cover most applications from 4" through 9".



Figure 50. Metal Reducers & Adapters.

### G7979—Phase Converter for Model G0673

Add 3-phase multi-motor capability to your single-phase electrical supply! Operate single or multiple motors, transformers, and resistance loads at 100% power and 95% efficiency while saving big dollars at cheaply-metered single-phase electrical rates.

### H2443—9½" x 6" Universal Adapter

Seven step adapter provides a multitude of dust collection reducing options.

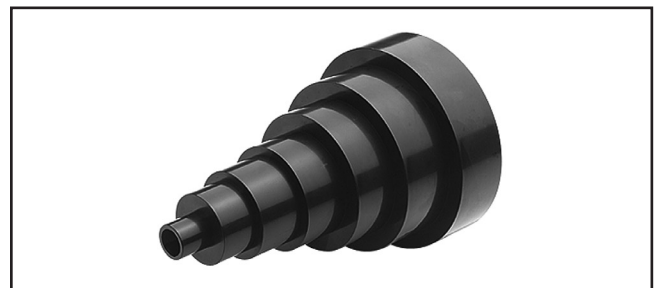
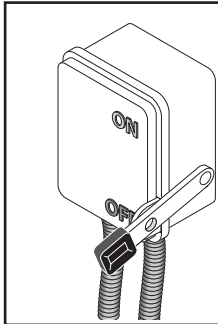

Figure 51. H2443 Universal Adapter.

G0671/G0672/G0673 Dust Collector



# SECTION 7: MAINTENANCE



## ⚠️ WARNING

Disconnect power to the machine when performing any maintenance, assembly or adjustments. Failure to do this may result in serious personal injury.

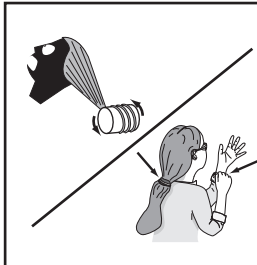

## ⚠️ WARNING

Keep loose clothing rolled up and out of the way of machinery and keep hair pulled back.

## Schedule

For optimum performance from your machine, follow this maintenance schedule and refer to any specific instructions given in this section.

### Daily Check:

- Dust collector is completely powered down at the end of use.
- Loose mounting bolts.
- Worn switch or wires.
- Any other condition that would hamper the safe operation of this machine.
- Empty the lower collection bags before they become completely full.

## Lubrication

Since all bearings are shielded and permanently lubricated, simply leave them alone until they need to be replaced. Do not lubricate them.

## Bag Cleaning

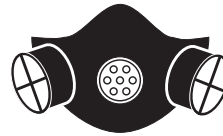

## ⚠️ CAUTION

All dust collectors disperse fine dust which may cause allergic reactions or respiratory problems. Always wear a respirator when operating your dust collector.

Empty the lower collection bags on a regular basis to maintain dust collection efficiency.

Always wear the appropriate respirator or dust mask and safety glasses when emptying the collection bags. Small dust particles can escape the bags during emptying, causing them to become airborne and easily inhaled. This microscopic airborne dust is extremely unhealthy to breathe and can cause serious health problems.

While the Model G0671/G0672/G0673 excels at collecting the majority of wood dust produced by your machines, we always recommend the supplemental aid of a shop air filter. Air filters are designed to collect the smaller airborne dust particles that a dust collector bags cannot trap.



# SECTION 8: SERVICE

Review the troubleshooting and procedures in this section to fix or adjust your machine if a problem develops. If you need replacement parts or you are unsure of your repair skills, then feel free to call our Technical Support at (570) 546-9663.

## Troubleshooting

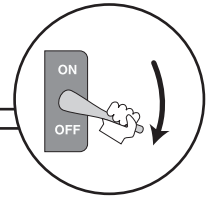

### Motor & Electrical

Symptom	Possible Cause	Possible Solution
Machine does not start or a breaker trips.	<ol style="list-style-type: none"> <li>1. Plug/receptacle is at fault or wired incorrectly.</li> <li>2. Motor connection wired incorrectly.</li> <li>3. Thermal overload relay has tripped.</li> <li>4. Contactor not getting energized/has burnt contacts.</li> <li>5. Power supply is at fault/switched OFF.</li> <li>6. Motor ON button or ON/OFF switch is at fault.</li> <li>7. Centrifugal switch is at fault.</li> <li>8. Wiring is open/has high resistance.</li> <li>9. Motor is at fault.</li> </ol>	<ol style="list-style-type: none"> <li>1. Test for good contacts; correct the wiring.</li> <li>2. Correct motor wiring connections.</li> <li>3. Turn cut-out dial to increase working amps and push the reset pin. Replace if tripped multiple times (weak relay).</li> <li>4. Test for power on all legs and contactor operation. Replace unit if faulty.</li> <li>5. Ensure hot lines have correct voltage on all legs and main power supply is switched ON.</li> <li>6. Replace faulty ON button or ON/OFF switch.</li> <li>7. Adjust/replace the centrifugal switch if available.</li> <li>8. Check for broken wires or disconnected/corroded connections, and repair/replace as necessary.</li> <li>9. Test/repair/replace.</li> </ol>
Machine stalls or is underpowered.	<ol style="list-style-type: none"> <li>1. Motor connection is wired incorrectly.</li> <li>2. Plug/receptacle is at fault.</li> <li>3. Motor bearings are at fault.</li> <li>4. Motor has overheated.</li> <li>5. Contactor not getting energized or has poor contacts.</li> <li>6. Motor is at fault.</li> <li>7. Centrifugal switch is at fault.</li> </ol>	<ol style="list-style-type: none"> <li>1. Correct motor wiring connections.</li> <li>2. Test for good contacts; correct the wiring.</li> <li>3. Test by rotating shaft; rotational grinding/loose shaft requires bearing replacement.</li> <li>4. Clean off motor, let cool, and reduce workload.</li> <li>5. Test for power on all legs and contactor operation. Replace if faulty.</li> <li>6. Test/repair/replace.</li> <li>7. Adjust/replace centrifugal switch if available.</li> </ol>
Machine has vibration or noisy operation.	<ol style="list-style-type: none"> <li>1. Motor or component is loose.</li> <li>2. Motor fan is rubbing on fan cover.</li> <li>3. Motor mount loose/broken.</li> <li>4. Motor bearings are at fault.</li> <li>5. Centrifugal switch.</li> </ol>	<ol style="list-style-type: none"> <li>1. Inspect/replace stripped or damaged bolts/nuts, and re-tighten with thread locking fluid.</li> <li>2. Replace dented fan cover; replace loose/damaged fan.</li> <li>3. Tighten/replace.</li> <li>4. Test by rotating shaft; rotational grinding/loose shaft requires bearing replacement.</li> <li>5. Replace.</li> </ol>



## Dust Collection Operation

SYMPTOM	POSSIBLE CAUSE	CORRECTIVE ACTION
Loud, repetitious noise, or excessive vibration coming from dust collector.	<ol style="list-style-type: none"> <li>1. Dust collector is not on a flat surface and wobbles.</li> <li>2. Impeller fan is damaged and unbalanced.</li> <li>3. The motor mounting is loose.</li> <li>4. Impeller is loose on the motor shaft.</li> <li>5. Motor fan cover is dented, causing the motor fan to hit the cover while spinning.</li> </ol>	<ol style="list-style-type: none"> <li>1. Stabilize the dust collector.</li> <li>2. Unplug dust collector, and inspect the impeller for dents, bends, loose fins. Replace impeller if any damage is found.</li> <li>3. Make sure all fasteners on the dust collector are tight.</li> <li>4. Replace the motor and impeller as a set if the motor shaft and the impeller hub is damaged.</li> <li>5. Replace motor fan cover.</li> </ol>
Dust collector does not adequately collect dust or chips; poor performance.	<ol style="list-style-type: none"> <li>1. Dust collection bag is full/filter bag is dirty.</li> <li>2. There is a restriction in the duct line.</li> <li>3. The dust collector is too far away from the point of suction, or there are too many sharp bends in the ducting.</li> <li>4. The lumber is wet and not flowing through the dust lines smoothly.</li> <li>5. There is a leak in the ducting, or a series of small leaks, or too many open ports.</li> <li>6. There are not enough open branch lines at one time, thereby causing a velocity drop in the main line.</li> <li>7. The ducting and ports are incorrectly sized.</li> <li>8. The machine dust collection design is inadequate.</li> <li>9. The dust collector is too small for the dust collection system.</li> </ol>	<ol style="list-style-type: none"> <li>1. Empty collection bag/clean or replace filter bag.</li> <li>2. Remove dust line from dust collector inlet and unblock the restriction in the duct line. A plumbing snake may be necessary.</li> <li>3. Relocate the dust collector closer to the point of suction, and rework ducting without sharp bends. Refer to <b>Designing the System</b>, beginning on <b>Page 26</b>.</li> <li>4. Process lumber with less than 20% moisture content.</li> <li>5. Rework the ducting to eliminate all leaks. Close dust ports for lines not being used. Refer to <b>Designing the System</b> on <b>Page 26</b> for more solutions.</li> <li>6. Open 1 or 2 more blast gates to different branch lines to allow the velocity in the main line to increase.</li> <li>7. Reinstall correctly sized ducts and fittings. Refer to <b>Designing the System</b> on <b>Page 26</b> for more solutions.</li> <li>8. Use a dust collection nozzle on a stand.</li> <li>9. Install a larger dust collector to power your dust collection system.</li> </ol>
Sawdust being blown into the air from the dust collector.	<ol style="list-style-type: none"> <li>1. Bag clamps, dust collection bag, or filter bag is not properly secured.</li> </ol>	<ol style="list-style-type: none"> <li>1. Reclamp the dust collection bag and air filter bag, making sure bag clamps are tight and completely over the bags.</li> </ol>



# SECTION 9: WIRING

## WARNING

### Electrical Safety Instructions

- 1. PRINTED INFORMATION.** The electrical information included in this section is current at the time of printing. However, in the spirit of improvement, we may make changes to the electrical system of future machines. Study the photos and diagrams in this section carefully. If you notice differences between your machine and these diagrams, call Technical Support at (570) 546-9663 for assistance.
- 2. SHOCK HAZARD.** Disconnect power from the machine before servicing electrical components. Touching electrified parts will result in personal injury including but not limited to severe burns, electrocution, or death.
- 3. GROUNDED CIRCUIT.** Electrocution or fire could result if the machine is not grounded and installed in compliance with electrical codes. Compliance **MUST** be verified by a qualified electrician.
- 4. CIRCUIT REQUIREMENTS.** You **MUST** follow the **CIRCUIT REQUIREMENTS** section on **Page 16**. **If you are unsure about the wiring codes in your area or you plan to connect your machine to a shared circuit, consult a qualified electrician.**
- 5. MOTOR WIRING.** The motor wiring shown in these diagrams are current at the time of printing, but it may not match your machine. Always use the wiring diagram inside the motor junction box.
- 6. EXPERIENCING DIFFICULTIES.** If at any time you are experiencing difficulties understanding the information included in this section, contact our Technical Support at (570) 546-9663.

## ***NOTICE***

The photos and diagrams included in this section are best viewed in color. You can view these pages in color at [www.grizzly.com](http://www.grizzly.com).



# G0671/G0672 Wiring Diagram



View this page in color at [www.grizzly.com](http://www.grizzly.com).

COLOR KEY	
BLACK	
GREEN	
RED	
WHITE	



Figure 52. G0671/G0672 switch wiring.

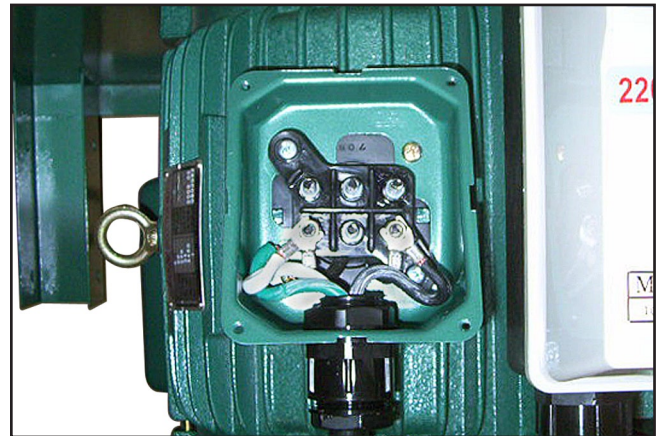
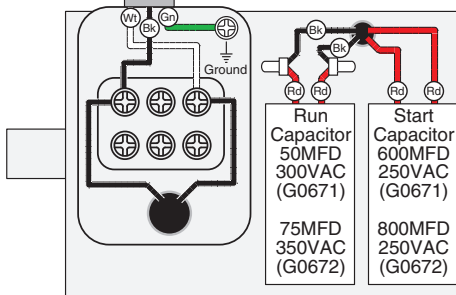
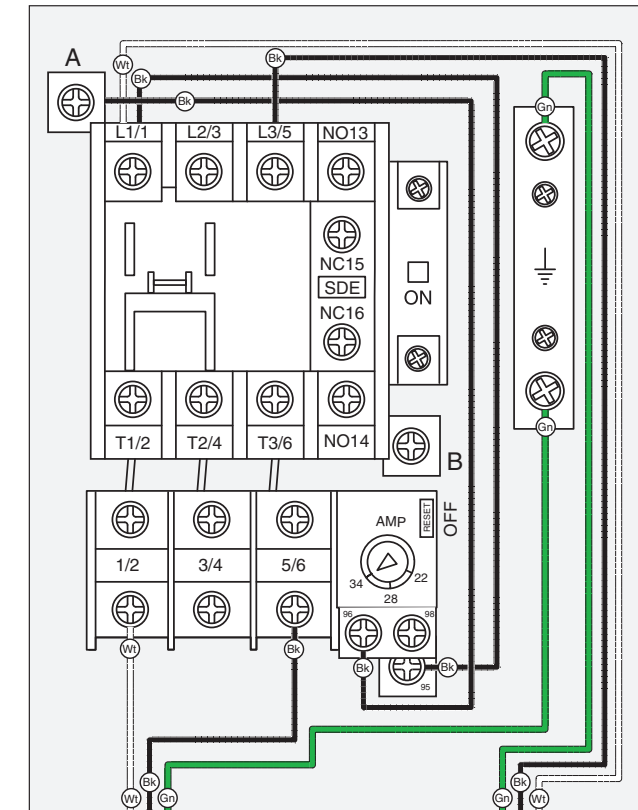

Figure 53. G0671/G0672 motor wiring.



MOTOR at 220V  
SINGLE PHASE

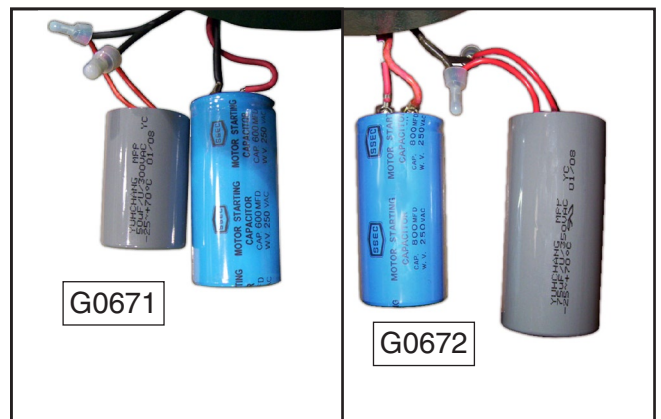

Figure 54. G0671/G0672 capacitors.



**Locking Shut-Off Switch  
(As Recommended)**



# G0673 Wiring Diagram



View this page in color at [www.grizzly.com](http://www.grizzly.com).

## MOTOR DIRECTION

### NOTICE

If motor rotates in opposite direction, swap any two power source wires at the incoming terminals.



## 3-PHASE 220 VAC

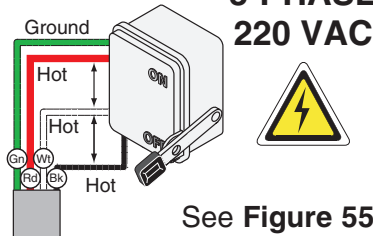

## COLOR KEY

BLACK	Bk
GREEN	Gn
RED	Rd
WHITE	Wl
YELLOW	Yl



## 3-PHASE 440 VAC

**DISCONNECT SWITCH**  
(as recommended)

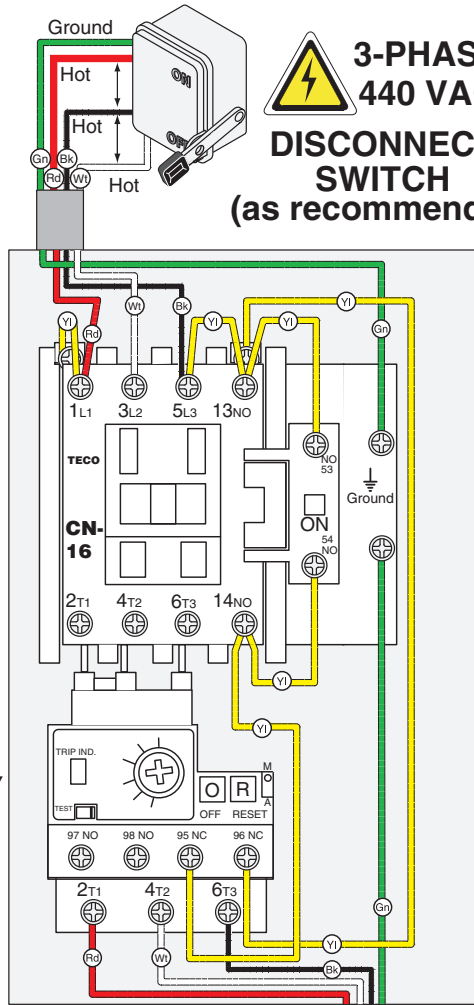

220V  
MAGNETIC  
SWITCH  
ASSEMBLY

440V  
MAGNETIC  
SWITCH  
ASSEMBLY  
(G8296)

See Figure 56

MOTOR  
at  
220V  
3-PHASE

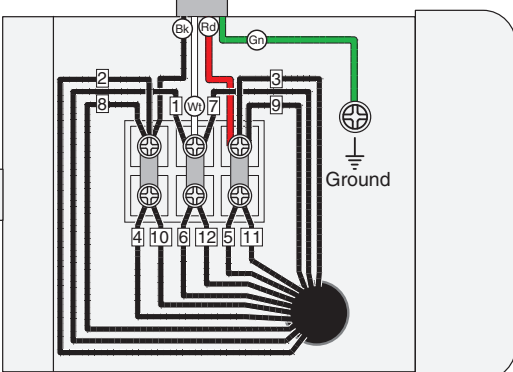

MOTOR  
at  
440V  
3-PHASE

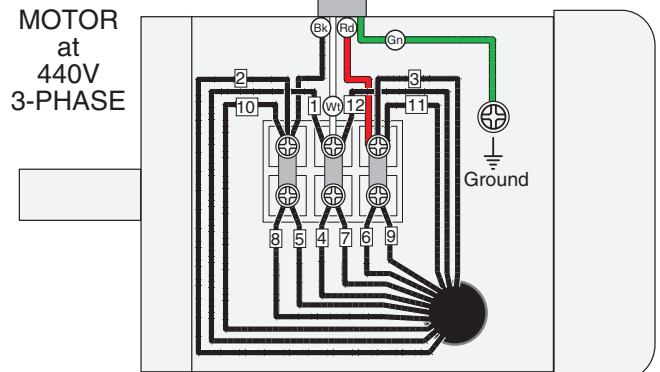



# G0673 Electrical Components

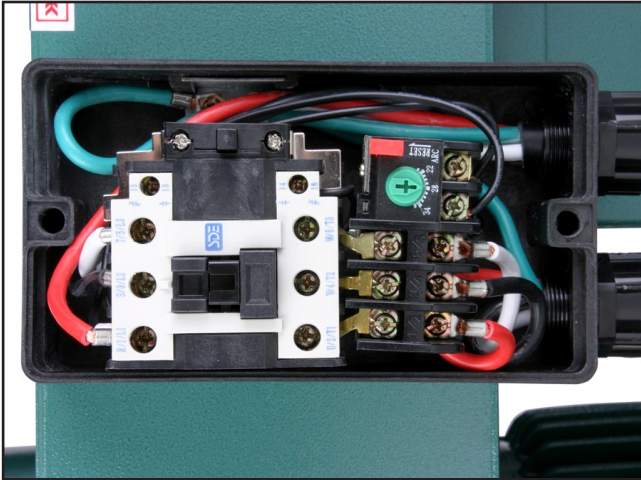

Figure 55. G0673 220V switch.

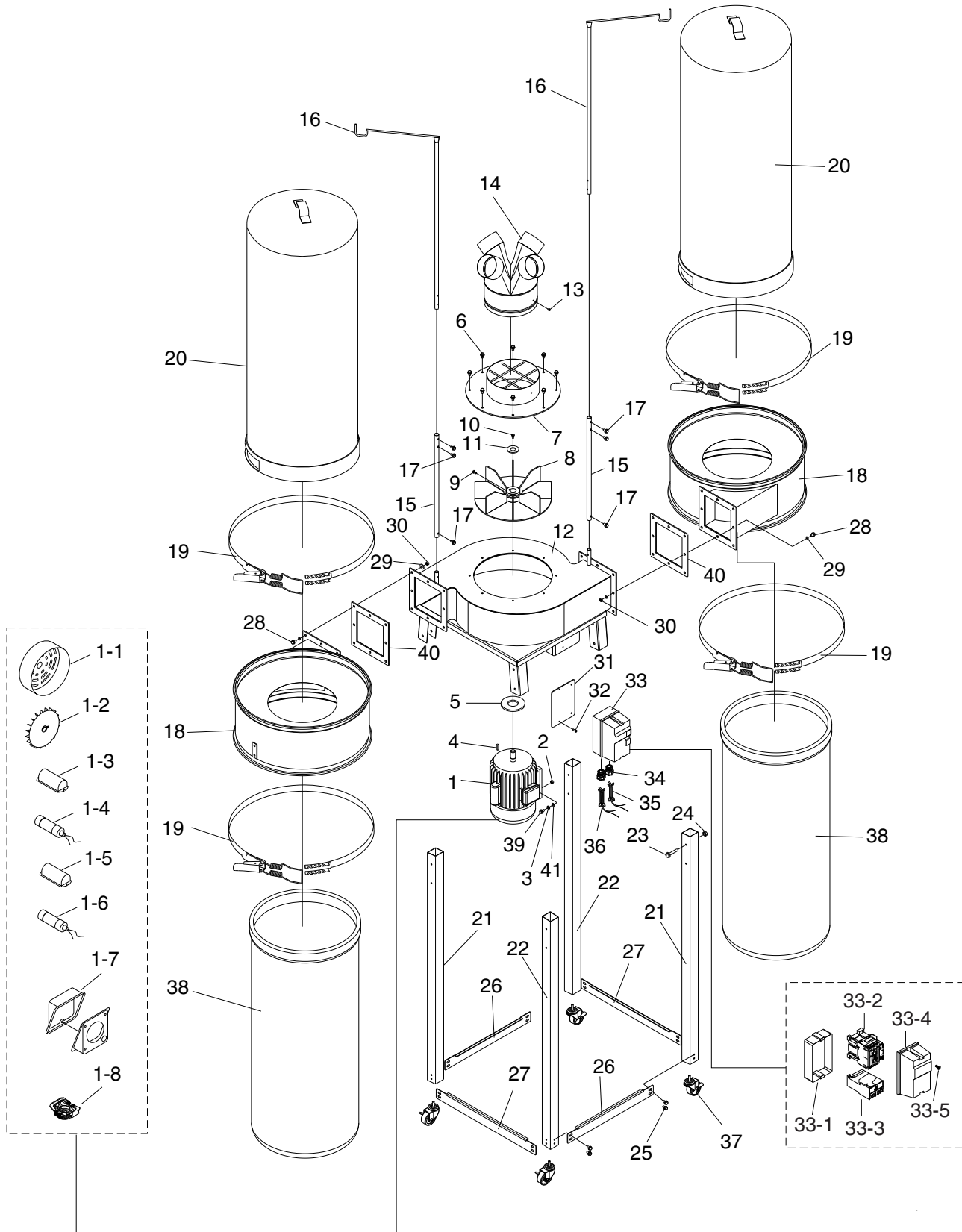

Figure 56. G0673 220V motor.



# SECTION 10: PARTS

## G0671 Parts Breakdown



# G0671 Parts List

REF	PART #	DESCRIPTION
1	P0671001	MOTOR 4HP, 220V, 1 PH
1-1	P0671001-1	FAN COVER
1-2	P0671001-2	FAN
1-3	P0671001-3	S CAPACITOR COVER
1-4	P0671001-4	S CAPACITOR 600M 250V X 1-3/4 X 3-7/8
1-5	P0671001-5	R CAPACITOR COVER
1-6	P0671001-6	R CAPACITOR 50M 300V X 1-3/4 X 2-3/4
1-7	P0671001-7	JUNCTION BOX
1-8	P0671001-8	CENTRIFUGAL SWITCH
2	PN08	HEX NUT 3/8-16
3	PLW04	LOCK WASHER 3/8
4	PK143M	KEY 6 X 6 X 25
5	P0671005	MOTOR GASKET
6	PB07	HEX BOLT 5/16-18 X 3/4
7	P0671007	INLET COVER
8	P0671008	IMPELLER 14-1/2"
9	PB34	HEX BOLT 3/8-16 X 1/2
10	PSB02M	CAP SCREW M6-1 X 20
11	PW03M	FLAT WASHER 6MM
12	P0671012	COLLECTOR HOUSING
13	PS06	PHLP HD SCR 10-24 X 3/8
14	P0671014	INLET ADAPTER
15	P0671015	BAG HANGER LOWER SUPPORT
16	P0671016	BAG HANGER
17	PB19	HEX BOLT 1/4-20 X 1/2
18	P0671018	COLLECTOR DRUM
19	P0671019	BAG CLAMP

REF	PART #	DESCRIPTION
20	P0671020	FILTER BAG 30 MICRON 23-5/8" X 47-1/4"
21	P0671021	RIGHT LEG
22	P0671022	LEFT LEG
23	PB23	HEX BOLT 5/16-18 X 2-1/2
24	PN02	HEX NUT 5/16-18
25	PB09	HEX BOLT 5/16-18 X 1/2
26	P0671026	F/R LEG BRACE
27	P0671027	L/R LEG BRACE
28	PB03	HEX BOLT 5/16-18 X 1
29	PW07	FLAT WASHER 5/16
30	PN02	HEX NUT 5/16-18
31	P0671031	MAGNETIC SWITCH PLATE
32	PS01	PHLP HD SCR 10-24 X 1/2
33	P0671033	MAGNETIC SWITCH
33-1	P0671033-1	MAG SWITCH BACK COVER
33-2	P0671033-2	CONTACTOR SDE MP-15 220V
33-3	P0671033-3	OL RELAY SDE RA-30 21-35
33-4	P0671033-4	MAG SWITCH FRONT COVER
33-5	P0671033-5	PLASTIC COVER SCREW 11/32-16 X 3/4
34	P0671034	STRAIN RELIEF
35	P0671035	MOTOR CORD 12AWG X 3C
36	P0671036	POWER CORD 12AWG X 3C
37	P0671037	CASTER WITH BRAKE
38	P0671038	LOWER DUST BAG 23-5/8" X 47-1/4"
39	PB24	HEX BOLT 3/8-16 X 1-1/4
40	P0671040	RUBBER GASKET
41	PW02	FLAT WASHER 3/8



# G0672 Parts Breakdown

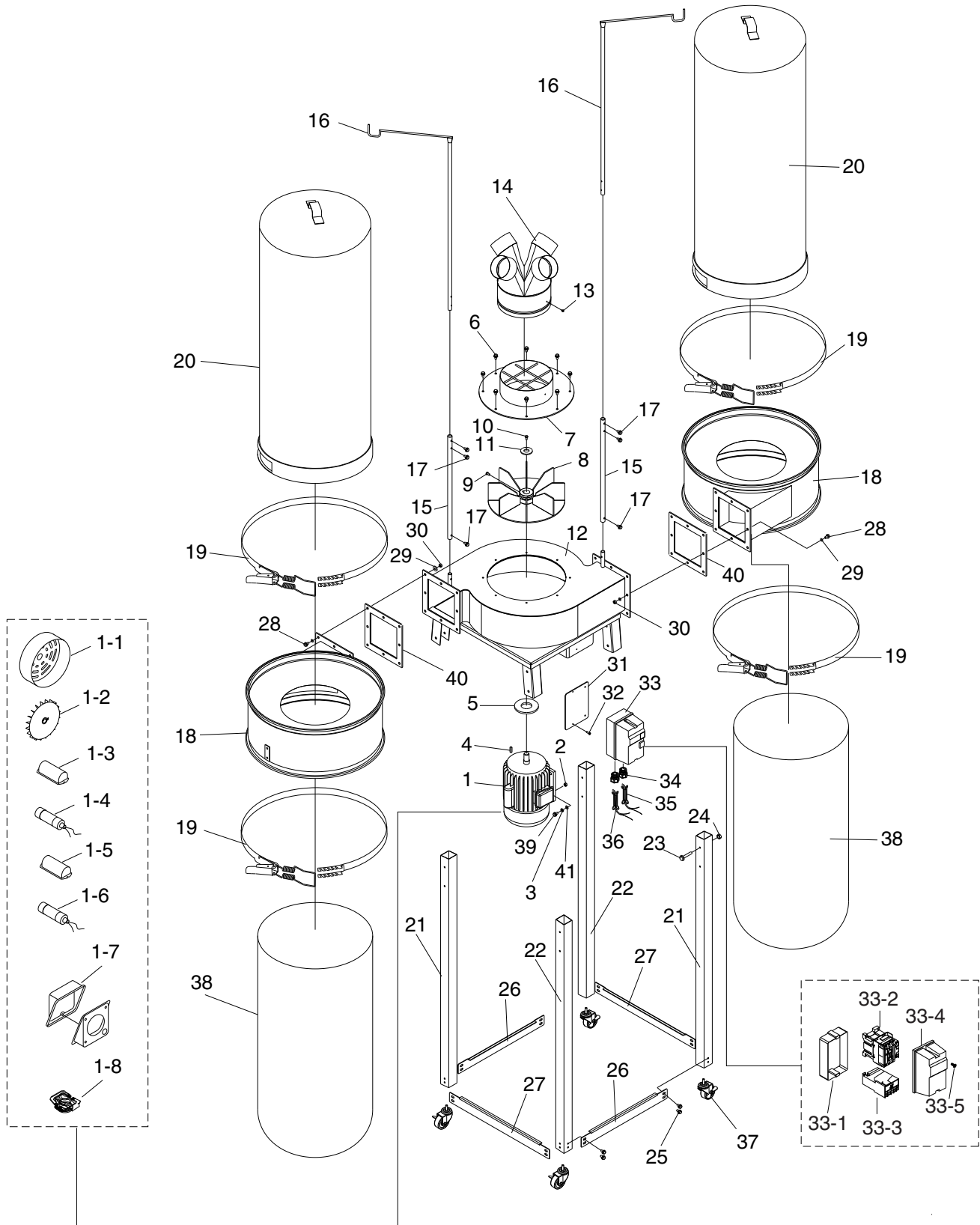

# G0672 Parts List

REF	PART #	DESCRIPTION
1	P0672001	MOTOR 5HP, 220V, 1 PH
1-1	P0672001-1	FAN COVER
1-2	P0672001-2	FAN
1-3	P0672001-3	S CAPACITOR COVER
1-4	P0672001-4	S CAPACITOR 800M 250V 1-3/4 X 3-3/4
1-5	P0672001-5	R CAPACITOR COVER
1-6	P0672001-6	R CAPACITOR 75M 350V 2 X 4-3/8
1-7	P0672001-7	JUNCTION BOX
1-8	P0672001-8	CENTRIFUGAL SWITCH
2	PN08	HEX NUT 3/8-16
3	PLW04	LOCK WASHER 3/8
4	PK143M	KEY 6 X 6 X 25
5	P0671005	MOTOR GASKET
6	PB07	HEX BOLT 5/16-18 X 3/4
7	P0671007	INLET COVER
8	P0672008	IMPELLER 15"
9	PB34	HEX BOLT 3/8-16 X 1/2
10	PSB02M	CAP SCREW M6-1 X 20
11	PW03M	FLAT WASHER 6MM
12	P0671012	COLLECTOR HOUSING
13	PS06	PHLP HD SCR 10-24 X 3/8
14	P0671014	INLET ADAPTER
15	P0672015	BAG HANGER LOWER SUPPORT
16	P0672016	BAG HANGER
17	PB19	HEX BOLT 1/4-20 X 1/2
18	P0671018	COLLECTOR DRUM
19	P0671019	BAG CLAMP

REF	PART #	DESCRIPTION
20	P0672020	FILTER BAG 2.5 MICRON 23-5/8" X 70"
21	P0671021	RIGHT LEG
22	P0671022	LEFT LEG
23	PB23	HEX BOLT 5/16-18 X 2-1/2
24	PN02	HEX NUT 5/16-18
25	PB09	HEX BOLT 5/16-18 X 1/2
26	P0671026	F/R LEG BRACE
27	P0671027	L/R LEG BRACE
28	PB03	HEX BOLT 5/16-18 X 1
29	PW07	FLAT WASHER 5/16
30	PN02	HEX NUT 5/16-18
31	P0671031	MAGNETIC SWITCH PLATE
32	PS01	PHLP HD SCR 10-24 X 1/2
33	P0671033	MAGNETIC SWITCH
33-1	P0671033-1	MAG SWITCH BACK COVER
33-2	P0671033-2	CONTACTOR SDE MP-15 220V
33-3	P0671033-3	OL RELAY SDE RA-30 21-35
33-4	P0671033-4	MAG SWITCH FRONT COVER
33-5	P0671033-5	PLASTIC COVER SCREW 11/32-16 X 3/4
34	P0672034	STRAIN RELIEF
35	P0672035	MOTOR CORD 10AWG X 3C
36	P0672036	POWER CORD 10AWG X 3C
37	P0671037	CASTER WITH BRAKE
38	P0672038	LOWER DUST BAG 23-5/8" X 57"
39	PB24	HEX BOLT 3/8-16 X 1-1/4
40	P0671040	RUBBER GASKET
41	PW02	FLAT WASHER 3/8



# G0673 Parts Breakdown

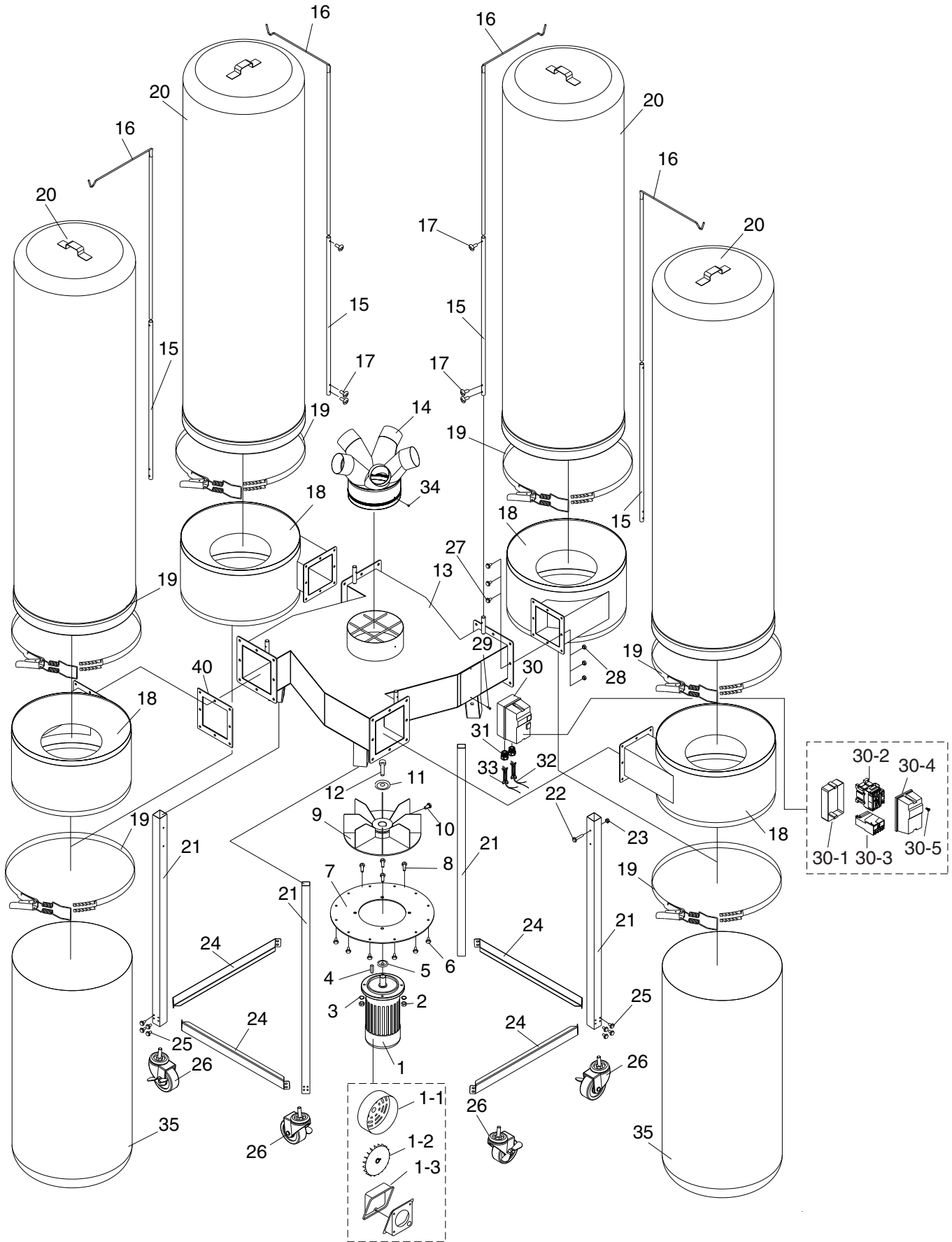



# G0673 Parts List

REF	PART #	DESCRIPTION
1	P0673001	MOTOR 10HP, 220V, 3 PH
1-1	P0673001-1	FAN COVER
1-2	P0673001-2	FAN
1-3	P0673001-3	JUNCTION BOX
2	PN41	HEX NUT 1/2"-12
3	PLW07	LOCK WASHER 1/2
4	PK149M	KEY 8 X 8 X 25
5	P0673005	MOTOR GASKET
6	PB07	HEX BOLT 5/16-18 X 3/4
7	P0673007	INLET COVER
8	P0673008	HEX BOLT 1/2 X 1-1/2
9	P0673009	IMPELLER 17"
10	PB16	HEX BOLT 3/8-16 X 1-1/2
11	PW03M	FLAT WASHER 6MM
12	PSB02M	CAP SCREW M6-1 X 20
13	P0673013	COLLECTOR HOUSING
14	P0673014	INLET ADAPTER
15	P0672015	BAG HANGER LOWER SUPPORT
16	P0672016	BAG HANGER
17	PB19	HEX BOLT 1/4-20 X 1/2
18	P0671018	COLLECTOR DRUM
19	P0671019	BAG CLAMP

REF	PART #	DESCRIPTION
20	P0672020	FILTER BAG 2.5 MICRON 23-5/8" X 70"
21	P0673021	LEG
22	PB23	HEX BOLT 5/16-18 X 2-1/2
23	PN02	HEX NUT 5/16-18
24	P0673024	LEG BRACE
25	PB09	HEX BOLT 5/16-18 X 1/2
26	P0671037	CASTER WITH BRAKE
27	PB03	HEX BOLT 5/16-18 X 1
28	PN02	HEX NUT 5/16-18
29	PS01	PHLP HD SCR 10-24 X 1/2
30	P0673030	MAGNETIC SWITCH
30-1	P0673030-1	MAG SWITCH BACK COVER
30-2	P0673030-2	CONTACTOR SDE MP-30 220V 3PH
30-3	P0671033-3	OL RELAY SDE RA-30 21-35
30-4	P0673030-4	MAG SWITCH FRONT COVER
30-5	P0671033-5	PLASTIC COVER SCREW 11/32-16 X 3/4
31	P0673031	STRAIN RELIEF
32	P0673032	MOTOR CORD 10AWG X 4C
33	P0673033	POWER CORD 10AWG X 4C
34	PS06	PHLP HD SCR 10-24 X 3/8
35	P0672038	LOWER DUST BAG 23-5/8" X 57"
40	P0671040	RUBBER GASKET



# Label Placement

G0671

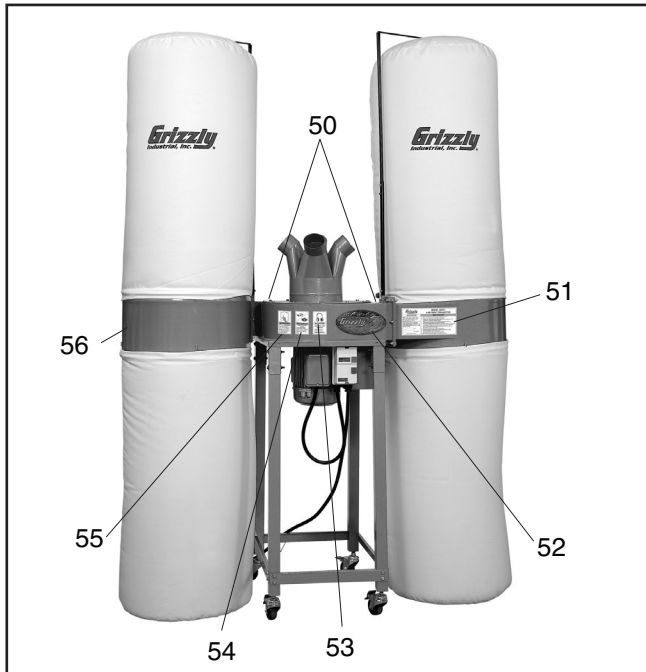

G0672

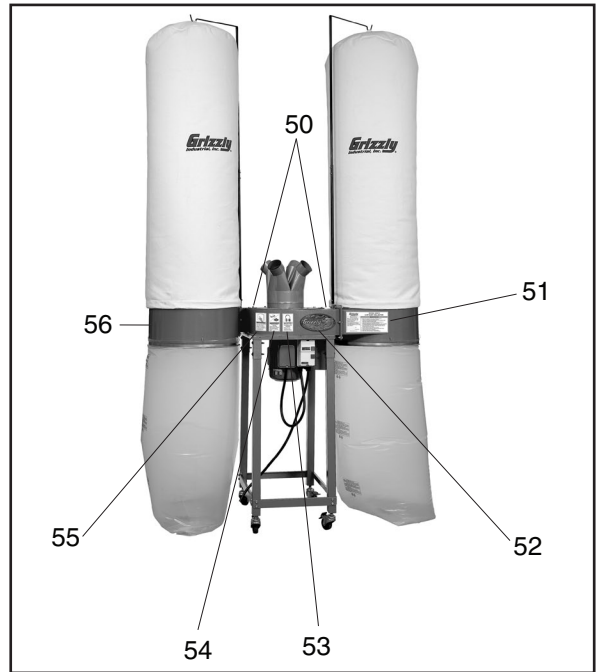

G0673

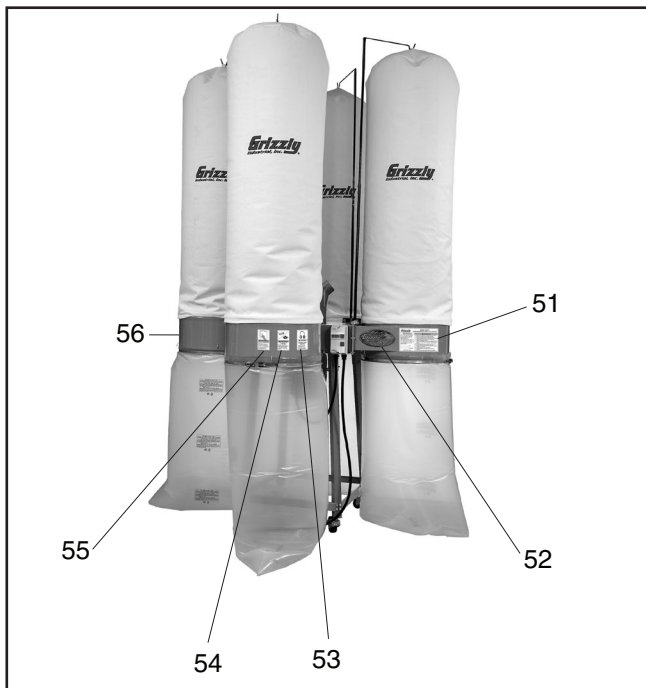

## REF PART # DESCRIPTION

REF	PART #	DESCRIPTION
50	P0671050	HANDS INLET WARNING (G0671, G0672)
51	P0671051	MACHINE ID LABEL (G0671)
51	P0672051	MACHINE ID LABEL (G0672)
51	P0673051	MACHINE ID LABEL (G0673)
52	G8588	GRIZZLY NAMEPLATE (G0671, G0672)
52	G9987	GRIZZLY NAMEPLATE (G0673)
53	PLABEL-15	EAR PROTECTION 2" X 3-5/16"H
54	PLABEL-37	GLASSES/RESPIRATOR
55	PLABEL-12A	READ MANUAL-VERTICAL NS 7/05
56	PPAINT-1	GRIZZLY GREEN TOUCH-UP PAINT

## WARNING

Safety labels warn about machine hazards and ways to prevent injury. The owner of this machine **MUST** maintain the original location and readability of the labels on the machine. If any label is removed or becomes unreadable, **REPLACE** that label before using the machine again. Contact Grizzly at (800) 523-4777 or [www.grizzly.com](http://www.grizzly.com) to order new labels.





# WARRANTY CARD

Name \_\_\_\_\_  
 Street \_\_\_\_\_  
 City \_\_\_\_\_ State \_\_\_\_\_ Zip \_\_\_\_\_  
 Phone # \_\_\_\_\_ Email \_\_\_\_\_ Invoice # \_\_\_\_\_  
 Model # \_\_\_\_\_ Order # \_\_\_\_\_ Serial # \_\_\_\_\_

The following information is given on a voluntary basis. It will be used for marketing purposes to help us develop better products and services. **Of course, all information is strictly confidential.**

1. How did you learn about us?

Advertisement                       Friend                       Catalog  
 Card Deck                               Website                       Other:

2. Which of the following magazines do you subscribe to?

<input type="checkbox"/> Cabinet Maker	<input type="checkbox"/> Popular Mechanics	<input type="checkbox"/> Today's Homeowner
<input type="checkbox"/> Family Handyman	<input type="checkbox"/> Popular Science	<input type="checkbox"/> Wood
<input type="checkbox"/> Hand Loader	<input type="checkbox"/> Popular Woodworking	<input type="checkbox"/> Wooden Boat
<input type="checkbox"/> Handy	<input type="checkbox"/> Practical Homeowner	<input type="checkbox"/> Woodshop News
<input type="checkbox"/> Home Shop Machinist	<input type="checkbox"/> Precision Shooter	<input type="checkbox"/> Woodsmith
<input type="checkbox"/> Journal of Light Cont.	<input type="checkbox"/> Projects in Metal	<input type="checkbox"/> Woodwork
<input type="checkbox"/> Live Steam	<input type="checkbox"/> RC Modeler	<input type="checkbox"/> Woodworker West
<input type="checkbox"/> Model Airplane News	<input type="checkbox"/> Rifle	<input type="checkbox"/> Woodworker's Journal
<input type="checkbox"/> Modeltec	<input type="checkbox"/> Shop Notes	<input type="checkbox"/> Other:
<input type="checkbox"/> Old House Journal	<input type="checkbox"/> Shotgun News	

3. What is your annual household income?

\$20,000-\$29,000                       \$30,000-\$39,000                       \$40,000-\$49,000  
 \$50,000-\$59,000                       \$60,000-\$69,000                       \$70,000+

4. What is your age group?

20-29     30-39     40-49  
 50-59     60-69     70+

5. How long have you been a woodworker/metalworker?

0-2 Years                       2-8 Years                       8-20 Years                       20+ Years

6. How many of your machines or tools are Grizzly?

0-2                       3-5                       6-9                       10+

7. Do you think your machine represents a good value?     Yes                       No

8. Would you recommend Grizzly Industrial to a friend?     Yes                       No

9. Would you allow us to use your name as a reference for Grizzly customers in your area?  
**Note: We never use names more than 3 times.**                       Yes                       No

10. Comments: \_\_\_\_\_  
 \_\_\_\_\_  
 \_\_\_\_\_  
 \_\_\_\_\_

CUT ALONG DOTTED LINE

FOLD ALONG DOTTED LINE

\_\_\_\_\_

\_\_\_\_\_

\_\_\_\_\_



Place  
Stamp  
Here



**GRIZZLY INDUSTRIAL, INC.**  
P.O. BOX 2069  
BELLINGHAM, WA 98227-2069



FOLD ALONG DOTTED LINE

Send a Grizzly Catalog to a friend:

Name _____
Street _____
City _____ State _____ Zip _____

TAPE ALONG EDGES--PLEASE DO NOT STAPLE

# WARRANTY AND RETURNS

---

Grizzly Industrial, Inc. warrants every product it sells for a period of **1 year** to the original purchaser from the date of purchase. This warranty does not apply to defects due directly or indirectly to misuse, abuse, negligence, accidents, repairs or alterations or lack of maintenance. This is Grizzly's sole written warranty and any and all warranties that may be implied by law, including any merchantability or fitness, for any particular purpose, are hereby limited to the duration of this written warranty. We do not warrant or represent that the merchandise complies with the provisions of any law or acts unless the manufacturer so warrants. In no event shall Grizzly's liability under this warranty exceed the purchase price paid for the product and any legal actions brought against Grizzly shall be tried in the State of Washington, County of Whatcom.

We shall in no event be liable for death, injuries to persons or property or for incidental, contingent, special, or consequential damages arising from the use of our products.

To take advantage of this warranty, contact us by mail or phone and give us all the details. We will then issue you a "Return Number," which must be clearly posted on the outside as well as the inside of the carton. We will not accept any item back without this number. Proof of purchase must accompany the merchandise.

The manufacturers reserve the right to change specifications at any time because they constantly strive to achieve better quality equipment. We make every effort to ensure that our products meet high quality and durability standards and we hope you never need to use this warranty.

Please feel free to write or call us if you have any questions about the machine or the manual.

Thank you again for your business and continued support. We hope to serve you again soon.

# *grizzly.com*

**TOOL WEBSITE**

Buy Direct and Save with Grizzly® – Trusted, Proven and a Great Value!

*Visit Our Website Today And Discover  
Why Grizzly® Is The Industry Leader!*

- SECURE ORDERING
- ORDERS SHIPPED WITHIN 24 HOURS
- E-MAIL RESPONSE WITHIN ONE HOUR

-OR-

Call Today For A **FREE**  
Full Color Catalog

**1-800-523-4777**





## Free Manuals Download Website

<http://myh66.com>

<http://usermanuals.us>

<http://www.somanuals.com>

<http://www.4manuals.cc>

<http://www.manual-lib.com>

<http://www.404manual.com>

<http://www.luxmanual.com>

<http://aubethermostatmanual.com>

Golf course search by state

<http://golfingnear.com>

Email search by domain

<http://emailbydomain.com>

Auto manuals search

<http://auto.somanuals.com>

TV manuals search

<http://tv.somanuals.com>