

Grizzly *Industrial, Inc.*®

MODEL G0508 10 HP INDUSTRIAL DUST COLLECTOR OWNER'S MANUAL



COPYRIGHT © NOVEMBER, 2006 BY GRIZZLY INDUSTRIAL, INC.
**WARNING: NO PORTION OF THIS MANUAL MAY BE REPRODUCED IN ANY SHAPE
OR FORM WITHOUT THE WRITTEN APPROVAL OF GRIZZLY INDUSTRIAL, INC.**
#TS8335 PRINTED IN TAIWAN

WARNING!

This manual provides critical safety instructions on the proper setup, operation, maintenance and service of this machine/equipment.

Failure to read, understand and follow the instructions given in this manual may result in serious personal injury, including amputation, electrocution or death.

The owner of this machine/equipment is solely responsible for its safe use. This responsibility includes but is not limited to proper installation in a safe environment, personnel training and usage authorization, proper inspection and maintenance, manual availability and comprehension, application of safety devices, blade/cutter integrity, and the usage of personal protective equipment.

The manufacturer will not be held liable for injury or property damage from negligence, improper training, machine modifications or misuse.

WARNING!

Some dust created by power sanding, sawing, grinding, drilling, and other construction activities contains chemicals known to the State of California to cause cancer, birth defects or other reproductive harm. Some examples of these chemicals are:

- **Lead from lead-based paints.**
- **Crystalline silica from bricks, cement and other masonry products.**
- **Arsenic and chromium from chemically-treated lumber.**

Your risk from these exposures varies, depending on how often you do this type of work. To reduce your exposure to these chemicals: Work in a well ventilated area, and work with approved safety equipment, such as those dust masks that are specially designed to filter out microscopic particles.

Table of Contents

INTRODUCTION	2
Foreword	2
Contact Info.....	2
Machine Data Sheet.....	3
Identification	5
SECTION 1: SAFETY	6
Safety Instructions for Machinery.....	7
Additional Safety for Dust Collectors	8
SECTION 2: CIRCUIT REQUIREMENTS	9
220/440V 3-Phase	9
Grounding.....	9
Rewiring to 440V	9
SECTION 3: SET UP	10
Set Up Safety	10
Items Needed for Setup	10
Unpacking	10
Inventory.....	11
Site Considerations	12
Assembly.....	12
Test Run.....	15
SECTION 4: DESIGNING THE SYSTEM	17
General.....	17
Duct Material	17
System Design	19
System Grounding	23
SECTION 5: ACCESSORIES	25
SECTION 6: OPERATIONS	28
General.....	28
SECTION 7: MAINTENANCE	29
Schedule	29
Lubrication.....	29
Bag Cleaning.....	29
SECTION 8: SERVICE	30
About Service	30
Troubleshooting.....	30
Electrical Components	31
Wiring Diagram	32
Parts Breakdown	33
Label Placement	35
WARRANTY AND RETURNS	36

INTRODUCTION

Foreword

We are proud to offer the Model G0508 10 HP Industrial Dust Collector. This machine is part of a growing Grizzly family of fine woodworking machinery. When used according to the guidelines set forth in this manual, you can expect years of trouble-free, enjoyable operation and proof of Grizzly's commitment to customer satisfaction.

We are pleased to provide this manual with the Model G0508; it will guide you through assembly, safety considerations, and general operating procedures. It represents our effort to produce the best documentation possible.

The specifications, drawings, and photographs illustrated in this manual represent the Model G0508 as supplied when the manual was prepared. However, owing to Grizzly's policy of continuous improvement, changes may be made at any time with no obligation on the part of Grizzly. For your convenience, we always keep current Grizzly manuals available on our website at **www.grizzly.com**. Any updates to your machine will be reflected in these manuals as soon as they are complete. Visit our site often to check for the latest updates to this manual!

Contact Info

If you have any comments regarding this manual, please write to us at the address below:

Grizzly Industrial, Inc.
c/o Technical Documentation Manager
P.O. Box 2069
Bellingham, WA 98227-2069
E-Mail: manuals@grizzly.com

We stand behind our machines. If you have any service questions or parts requests, please call or write us at the location listed below.

Grizzly Industrial, Inc.
1203 Lycoming Mall Circle
Muncy, PA 17756
Phone: (570) 546-9663
Fax: (800) 438-5901
E-Mail: techsupport@grizzly.com
Web Site: <http://www.grizzly.com>





MACHINE DATA SHEET

Customer Service #: (570) 546-9663 • To Order Call: (800) 523-4777 • Fax #: (800) 438-5901

MODEL G0508 10 HP INDUSTRIAL DUST COLLECTOR

Product Dimensions:

Weight515 lbs.
Length/Width/Height61 x 61 x 134 in.
Foot Print (Length/Width).....61 x 61 in.

Shipping Dimensions:

TypeCardboard/Wood Frame
Content.....Machine
Weight.....560 lbs.
Length/Width/Height.....47 x 53 x 31 in.

Electrical:

Switch.....Magnetic with Thermal Overload Relay
Switch Voltage220V
Cord Length12 ft.
Cord Gauge10 gauge
Recommended Breaker Size.....40 amp
Plug.....No
Conversion To 440V.....Part Number P0508037
Phase Converter.....Model G7979

Motors:

TypeTEFC Induction
Horsepower.....10 HP
Voltage220/440V
Prewired.....220V
Phase.....Three
Amps.....26/13A
Speed.....3450 RPM
Cycle60 Hz
Number Of Speeds1
Power Transfer.....Direct Drive
Bearings.....Shielded and Lubricated

Main Specifications:

Air Suction Capacity6700 CFM
Maximum Static Pressure Rating21 in.
Main Inlet Size9 in.
Manifold Included.....Yes
Manifold Inlets.....5
Manifold Inlet Size4 in.
Machine Collection Capacity8 Machines
Maximum Material Collection Capacity.....64.8 cu. ft.
Upper Bag Filtration.....2.5 micron



Bag Information

Number of Upper Bags	4
Upper Bag Capacity	17.8 cu. ft.
Lower Bag Capacity	13.7 cu. ft.
Number of Lower Bags	4
Upper Bags Total Area	71 cu. ft.
Lower Bags Total Area	54.8 cu. ft.
Upper Bag Diameter	23-5/8 in.
Upper Bag Length70 in.
Lower Bag Diameter	23-5/8 in.
Lower Bag Length54 in.

Impeller Information

Impeller Type	Radial Fin
Impeller Size	14-3/4 in.
Impeller Blade Thickness	1/4 in.

Construction

Upper Bag Material	Woven Fabric
Lower Bag Material	Plastic
Base Construction	Pre-Formed Steel on Casters
Frame Construction	Formed Steel
Caster Construction	Plastic
Impeller Construction	Balanced Welded Steel
Paint	Powder Coated

Other Specifications:

ISO Factory	ISO 9001
Country Of Origin	Taiwan
Warranty	1 Year
Serial Number Location	Data Label on Machine
Assembly Time	1-1/2 hours

Features:

- 10 HP Industrial Motor
- 4 Heavy Duty Plastic Collection Bags
- 4 filtration Bags
- Includes Steel Base with Casters



Identification



Figure 1. Dust collector, front view.

- A. Upper Filter Bag
- B. Collector
- C. Lower Collection Bag
- D. Caster
- E. Upper Bag Hanger Assembly
- F. Inlet
- G. ON/OFF Power Switch
- H. Motor
- I. Base

SECTION 1: SAFETY

WARNING

For Your Own Safety, Read Instruction Manual Before Operating this Machine

The purpose of safety symbols is to attract your attention to possible hazardous conditions. This manual uses a series of symbols and signal words intended to convey the level of importance of the safety messages. The progression of symbols is described below. Remember that safety messages by themselves do not eliminate danger and are not a substitute for proper accident prevention measures.



Indicates an imminently hazardous situation which, if not avoided, **WILL** result in death or serious injury.



Indicates a potentially hazardous situation which, if not avoided, **COULD** result in death or serious injury.



Indicates a potentially hazardous situation which, if not avoided, **MAY** result in minor or moderate injury. It may also be used to alert against unsafe practices.

NOTICE

This symbol is used to alert the user to useful information about proper operation of the machine.

WARNING

Safety Instructions for Machinery

- 1. READ THE ENTIRE MANUAL BEFORE STARTING MACHINERY.** Machinery presents serious injury hazards to untrained users.
- 2. ALWAYS USE ANSI APPROVED SAFETY GLASSES WHEN OPERATING MACHINERY.** Everyday eyeglasses only have impact resistant lenses—they are NOT safety glasses.
- 3. ALWAYS WEAR A NIOSH APPROVED RESPIRATOR WHEN OPERATING MACHINERY THAT PRODUCES DUST.** Wood dust can cause severe respiratory illnesses.
- 4. ALWAYS USE HEARING PROTECTION WHEN OPERATING MACHINERY.** Machinery noise can cause permanent hearing loss.
- 5. WEAR PROPER APPAREL. DO NOT** wear loose clothing, gloves, neckties, rings, or jewelry that can catch in moving parts. Wear protective hair covering to contain long hair and wear non-slip footwear.
- 6. NEVER OPERATE MACHINERY WHEN TIRED OR UNDER THE INFLUENCE OF DRUGS OR ALCOHOL.** Be mentally alert at all times when running machinery.



WARNING

Safety Instructions for Machinery

7. **ONLY ALLOW TRAINED AND PROPERLY SUPERVISED PERSONNEL TO OPERATE MACHINERY.** Make sure operation instructions are safe and clearly understood.
8. **KEEP CHILDREN AND VISITORS AWAY.** Keep all children and visitors a safe distance from the work area.
9. **MAKE WORKSHOP CHILDPROOF.** Use padlocks, master switches, and remove start switch keys.
10. **NEVER LEAVE WHEN MACHINE IS RUNNING.** Turn power **OFF** and allow all moving parts to come to a complete stop before leaving machine unattended.
11. **DO NOT USE IN DANGEROUS ENVIRONMENTS.** DO NOT use machinery in damp, wet locations, or where any flammable or noxious fumes may exist.
12. **KEEP WORK AREA CLEAN AND WELL LIGHTED.** Clutter and dark shadows may cause accidents.
13. **USE A GROUNDED EXTENSION CORD RATED FOR THE MACHINE AMPERAGE.** Grounded cords minimize shock hazards. Undersized cords create excessive heat. Always replace damaged extension cords.
14. **ALWAYS DISCONNECT FROM POWER SOURCE BEFORE SERVICING MACHINERY.** Make sure switch is in OFF position before reconnecting.
15. **MAINTAIN MACHINERY WITH CARE.** Keep blades sharp and clean for best and safest performance. Follow instructions for lubricating and changing accessories.
16. **MAKE SURE GUARDS ARE IN PLACE AND WORK CORRECTLY BEFORE USING MACHINERY.**
17. **REMOVE ADJUSTING KEYS AND WRENCHES.** Make a habit of checking for keys and adjusting wrenches before turning machinery **ON**.
18. **CHECK FOR DAMAGED PARTS BEFORE USING MACHINERY.** Check for binding or misaligned parts, broken parts, loose bolts, and any other conditions that may impair machine operation. Repair or replace damaged parts before operation.
19. **USE RECOMMENDED ACCESSORIES.** Refer to the instruction manual for recommended accessories. Improper accessories increase risk of injury.
20. **DO NOT FORCE MACHINERY.** Work at the speed for which the machine or accessory was designed.
21. **SECURE WORKPIECE.** Use clamps or a vise to hold the workpiece when practical. A secured workpiece protects your hands and frees both hands to operate the machine.
22. **DO NOT OVERREACH.** Maintain stability and balance at all times.
23. **MANY MACHINES CAN EJECT WORKPIECES TOWARD OPERATOR.** Know and avoid conditions that cause the workpiece to "kickback."
24. **ALWAYS LOCK MOBILE BASES (IF USED) BEFORE OPERATING MACHINERY.**
25. **CERTAIN DUST MAY BE HAZARDOUS** to the respiratory systems of people and animals, especially fine dust. Be aware of the type of dust you are exposed to and always wear a respirator designed to filter that type of dust.



WARNING

Additional Safety for Dust Collectors

- 1. MACHINE USE.** Do not use this dust collector to pick up liquids and metal scrap including, but not limited to, nails and filings. Also, do not pick up material which cannot safely pass through the impeller such as solid wood scraps.
- 2. KEEPING FINGERS SAFE.** Do not place your hands or tools near the open inlet during operation for any reason including, but not limited to, unclogging material and testing suction. The impeller could cause serious damage to body parts if touched while spinning.
- 3. SAFE SERVICING.** Disconnect power and allow impeller to come to a complete stop before servicing or working on the dust collector ducting system.
- 4. SUSPENDED DUST PARTICLES AND IGNITION SOURCES.** Do not operate the dust collector in areas where explosion risks would be high if dust were dispersed into the area. Areas of high risk include, but are not limited to, areas near pilot lights and/or open flames.
- 5. DUST HAZARD.** Be aware that certain woods may cause an allergic reaction in people and animals, especially when exposed to fine dust. Make sure you know what type of wood dust you will be exposed to in case there is a possibility of an allergic reaction. Always wear an approved respirator during and for a short time after machine operation!
- 6. AVOIDING FIRES.** Do not allow steel to strike against impeller—this may produce a spark. Sparks can smolder in wood dust for a long time before fire or flame is detected. If metal contacts metal during operation, immediately turn off the dust collector, unplug the power cord from the outlet or flip the disconnect switch and wait for all moving parts to stop. Remove collection bags and empty the dust into an approved air tight metal container in case of spark. Remedy the metal to metal contact problem before resuming operation.
- 7. OPERATIONAL QUESTIONS.** If at any time you are experiencing difficulties performing the intended operation, stop using the machine! Then contact our Tech Support or ask a qualified expert how the operation should be performed.
- 8. CLEANING AIR.** Do not confuse this dust collector with an air cleaner. This dust collector is only designed to collect dust from a machine, not clean dust suspended in the air.
- 9. EMPTYING DUST.** When emptying dust from the collection bags or drum, wear a respirator and safety glasses. Empty dust into an approved container and dispose of properly.

WARNING

Like all machines there is danger associated with this machine. Accidents are frequently caused by lack of familiarity or failure to pay attention. Use this machine with respect and caution to lessen the possibility of operator injury. If normal safety precautions are overlooked or ignored, serious personal injury may occur.

CAUTION

No list of safety guidelines can be complete. Every shop environment is different. Always consider safety first, as it applies to your individual working conditions. Use this and other machinery with caution and respect. Failure to do so could result in serious personal injury, damage to equipment, or poor work results.



SECTION 2: CIRCUIT REQUIREMENTS

220/440V 3-Phase

WARNING

Serious personal injury could occur if you connect your machine to the power source before you have completed the set up process. DO NOT connect the machine to the power source until instructed to do so.

Amperage Draw

The Model G0508 features a 220/440V motor that is prewired for 220V and draws the following amps under maximum load:

Motor Draw at 220V 26 Amps
Motor Draw at 440V 13 Amps

Circuit Requirements

We recommend connecting your machine to a dedicated and grounded circuit that is rated for the amperage given below. Never replace a circuit breaker on an existing circuit with one of higher amperage without consulting a qualified electrician to ensure compliance with wiring codes. **If you are unsure about the wiring codes in your area or you plan to connect your machine to a shared circuit, consult a qualified electrician.**

220V Circuit..... 40 Amps
440V Circuit..... 20 Amps



Connection to Power

Have a qualified electrician hardwire this machine to a dedicated locking shut-off switch that is connected to the main power source.

Grounding

In the event of an electrical short, grounding reduces the risk of electric shock. The grounding wire in the power cord must be properly connected to the grounding prong on the plug; likewise, the outlet must be properly installed and grounded. All electrical connections must be made in accordance with local codes and ordinances.

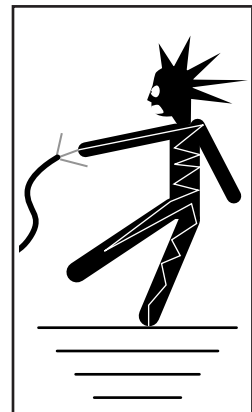
Improper connections of the electrical-grounding conductor increases the risk of electric shock. Check with a qualified electrician or one of our service personnel if you do not understand the grounding instructions, or if you doubt the machine is properly grounded.

	<h3> WARNING</h3> <p>Electrocution or fire could result if this machine is not installed correctly or the electrical installation does not comply with local and state codes. Ensure compliance by using a qualified electrician for the electrical installation!</p>
---	--

Rewiring to 440V

The Model G0508 can be rewired for 440V operation. This rewiring job consists of disconnecting the dust collector from the power source, changing the magnetic switch, and rewiring the motor.

The necessary magnetic switch for this procedure can be purchased by calling our customer service number at (800) 523-4777 and ordering part number P0508037.

This procedure takes moderate electrical skill and the rewiring job must be inspected by a qualified electrician before the dust collector is connected to the power source.



SECTION 3: SET UP

Set Up Safety

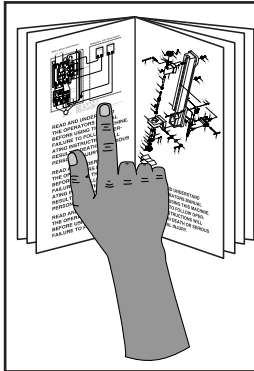

!WARNING

This machine presents serious injury hazards to untrained users. Read through this entire manual to become familiar with the controls and operations before starting the machine!



!WARNING

Wear safety glasses during the entire set up process!



!WARNING

The Model G0508 is a heavy machine. DO NOT over-exert yourself while unpacking or moving your machine—get assistance.



!CAUTION

Some metal parts may have sharp edges on them after they are formed. Please examine the edges of all metal parts before handling them. Failure to do so could result in injury.

Items Needed for Setup

The following items are needed to complete the set up process, but are not included with your machine:

Description	Qty
• Assistant.....	1 or more
• Safety Glasses (for each person)	1
• Gloves (for each person).....	1
• Phillips Head Screwdriver	1
• Wrench 10mm.....	1
• Wrenches 12mm	2
• Ladder (for hanging upper bag)	1

Unpacking

The Model G0508 was carefully packed when it left our warehouse. If you discover the machine is damaged after you have signed for delivery, please immediately call Customer Service at (570) 546-9663 for advice.

Save the containers and all packing materials for possible inspection by the carrier or its agent. Otherwise, filing a freight claim can be difficult.

When you are completely satisfied with the condition of your shipment, you should inventory the contents.

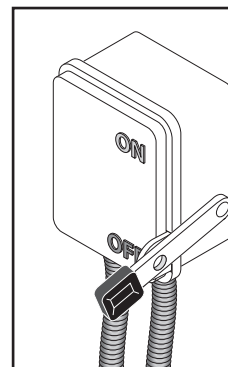

!WARNING

Turn **OFF** the power at the power disconnect and do **NOT** turn **ON** until instructed to do so. Failure to heed this warning could result in serious personal injury or death.

Inventory

After all the parts have been removed from the two boxes, you should have the following items:

Contents (Figure 2-4)	Qty
A. Main Housing with Motor.....	1
B. Inlet.....	1
C. Collectors	4
D. Supporting Legs	4
E. Base	1
F. Hanger Supports	4
G. Hangers.....	4
H. Upper Filter Bags (fabric)	4
I. Lower Collection Bags (plastic).....	4
J. Casters	4
K. Rubber Gaskets	4
L. Bag Clamps.....	8
M. Hardware Bag (not shown).....	1
— Combo Wrench 10/12mm.....	1
— Phillips Head Screw M6-1.0 x 10	1
— Flange Bolts 1/4"-20 x 1/2".....	12
— Flange Bolts 5/16"-18 x 1/2".....	32
— Flat Washers 5/16".....	64
— Hex Bolts 5/16"-18 x 1".....	32
— Hex Nuts 5/16"-18	32

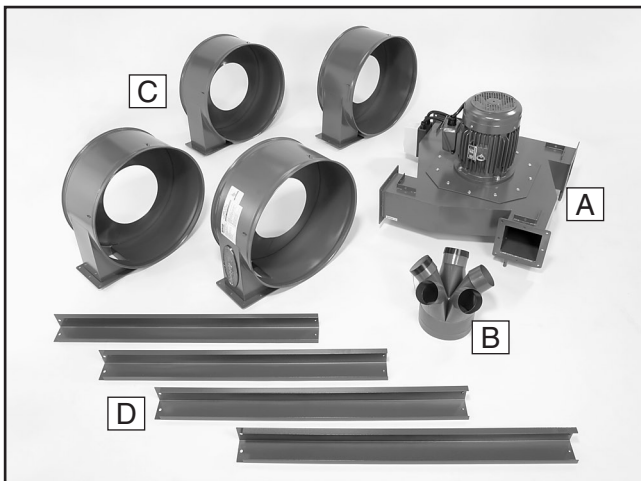

Figure 2. Model G0508 Inventory (A–D).

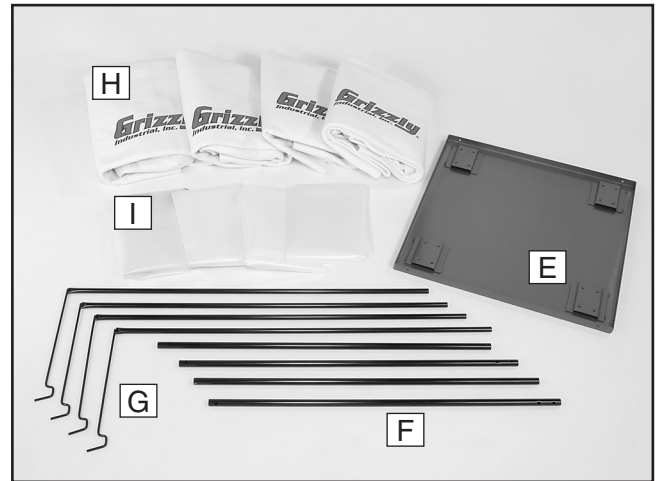

Figure 3. Model G0508 Inventory (E–I).

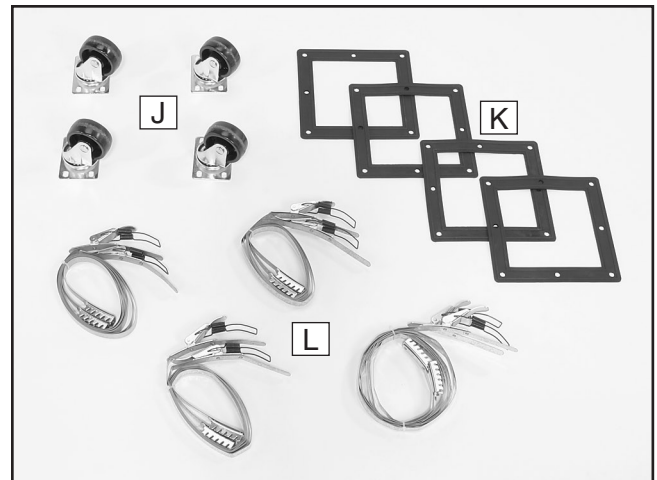

Figure 4. Model G0508 Inventory (J–L).

In the event that any nonproprietary parts are missing (e.g., a nut or a washer), we would be glad to replace them, or for the sake of expediency, replacements can be obtained at your local hardware store.

NOTICE

Some hardware/fasteners listed in the inventory may arrive pre-installed on the machine. Check these locations before assuming that any items from the inventory list are missing.

Site Considerations

Floor Load

Refer to the **Machine Data Sheet** on **Page 3** for the weight and footprint specifications of your machine. Some floors may require additional reinforcement to support both the machine and operator.

Placement Location

Consider existing and anticipated needs, size of material to be processed through each machine, and space for auxiliary stands, work tables or other machinery when establishing a location for your new machine. See **Figure 5** for the minimum working clearances.

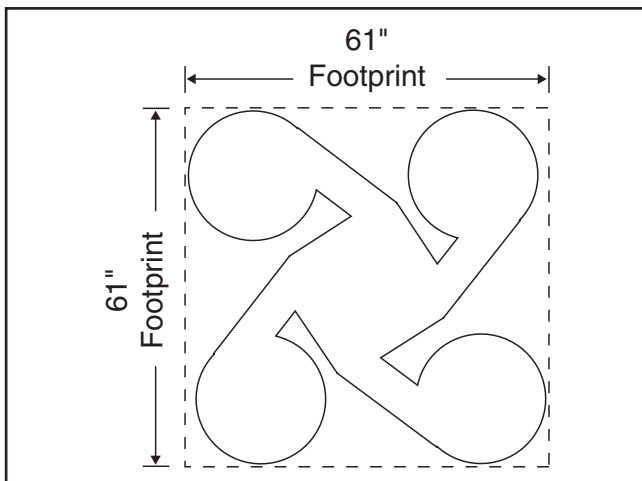

Figure 5. Model G0508 illustrated top view and suggested clearances.

Assembly

To the dust collector system:

1. Place the base upside down on the floor.
2. Attach the casters with the (16) $\frac{5}{16}$ "-18 x $\frac{1}{2}$ " flange bolts (see **Figure 6**).

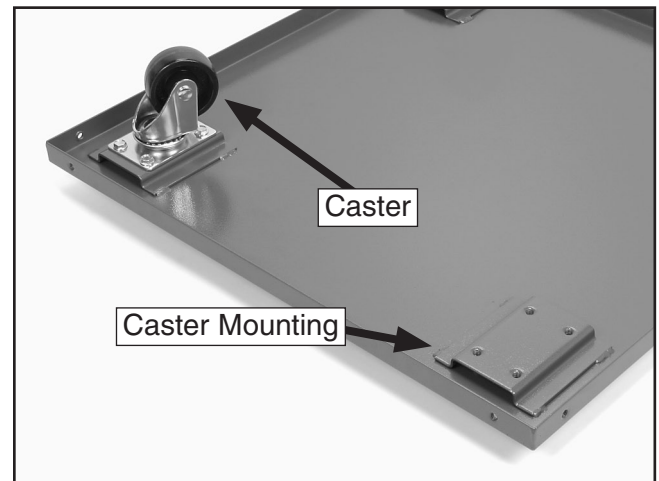

Figure 6. Caster mounted on base.

3. With assistance, place the main housing on the floor so that the motor is pointing up.
4. Place the end of the supporting leg with the threaded holes on the inside of the housing bracket (see **Figure 7**).

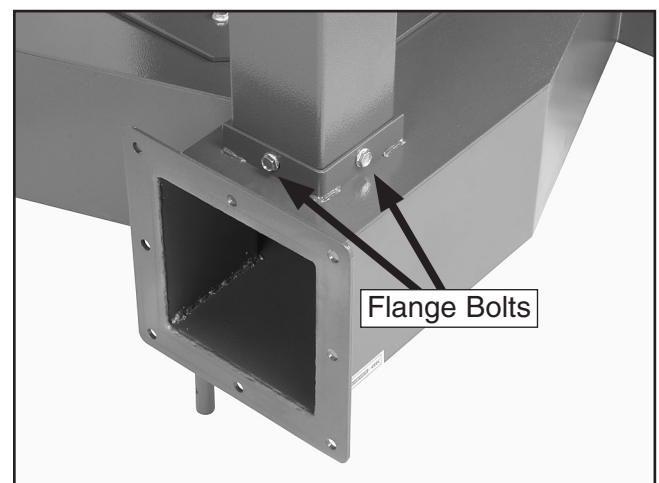

Figure 7. Supporting leg mounted to main housing.

5. Attach the supporting legs to the housing bracket with $\frac{5}{16}$ "-18 x $\frac{1}{2}$ " flange bolts.
6. Position the base on top of the supporting legs (see **Figure 8**).

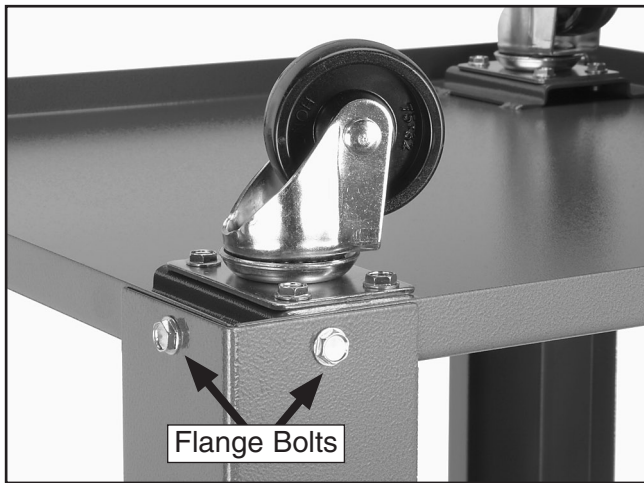

Figure 8. Base attached to supporting leg.

7. Fasten the supporting legs to the base with $\frac{5}{16}$ "-18 x $\frac{1}{2}$ " flange bolts.
8. With assistance, turn the entire assembly over so that the casters rest on the floor.
9. Position and hold the rubber gasket against the square opening in the main housing (see **Figure 9**).

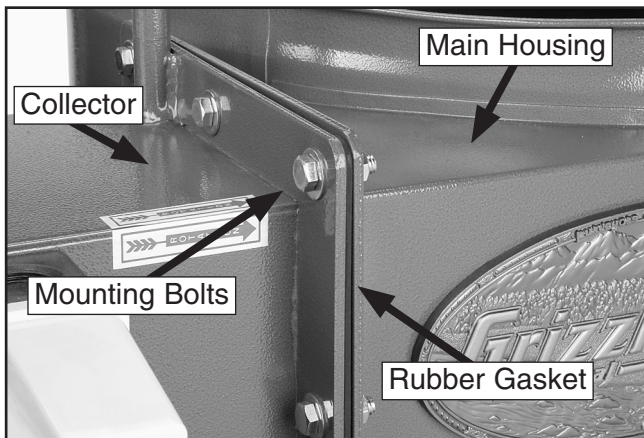

Figure 9. Collector mounted to main housing.

10. With assistance, position and hold the collector so the holes in the collector flange match with those of the rubber gasket and main housing.
11. Insert and hand tighten one $\frac{5}{16}$ "-18 x 1" flange bolt, two $\frac{5}{16}$ " flat washers, and one $\frac{5}{16}$ "-18 hex nut in all eight holes.
12. Tighten the eight flange bolts and nuts in an alternating fashion so that the rubber gasket is evenly compressed without deformation.
13. Repeat **Steps 10–13** for the remaining collectors.
14. Place the inlet on the top center circular flange of the main housing (see **Figure 10**).

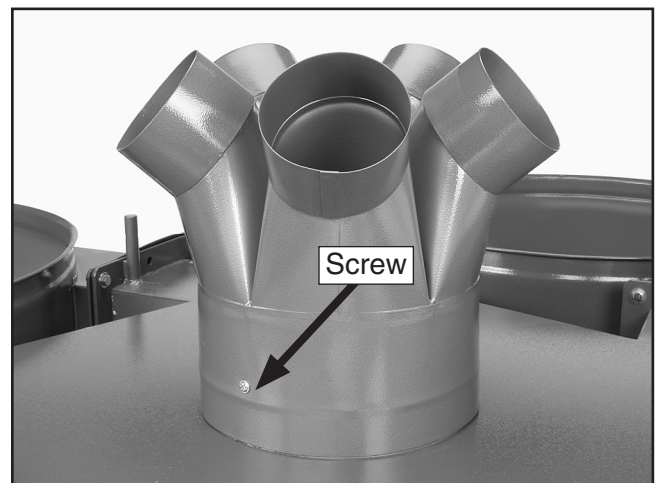

Figure 10. Inlet mounted on main housing.

15. Rotate the inlet so the hole in the inlet aligns with the hole in the housing flange.
16. Use the M6-1 x 10 Phillips head screw to fasten the inlet securely to the housing flange.

17. Slide the hanger into the hanger support, aligning the two holes on each part.
18. Secure this hanger assembly with two $\frac{1}{4}$ "-20 x $\frac{1}{2}$ " flange bolts (see **Figure 11**).

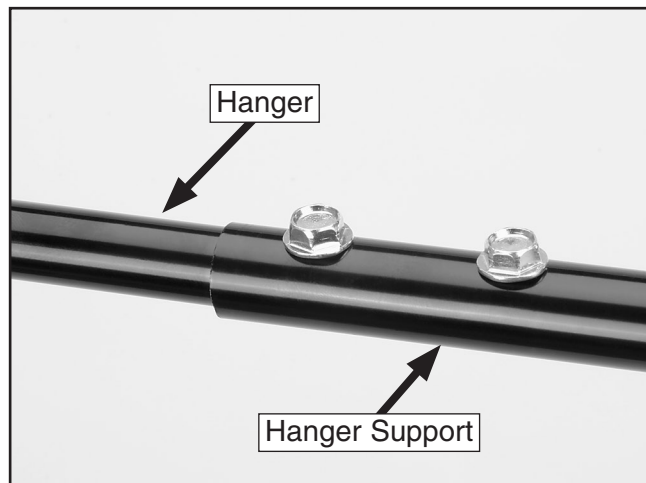

Figure 11. Hanger attached to hanger support.

19. Mount the hanger assembly on the protruding rod on the collector as shown in **Figure 12**.

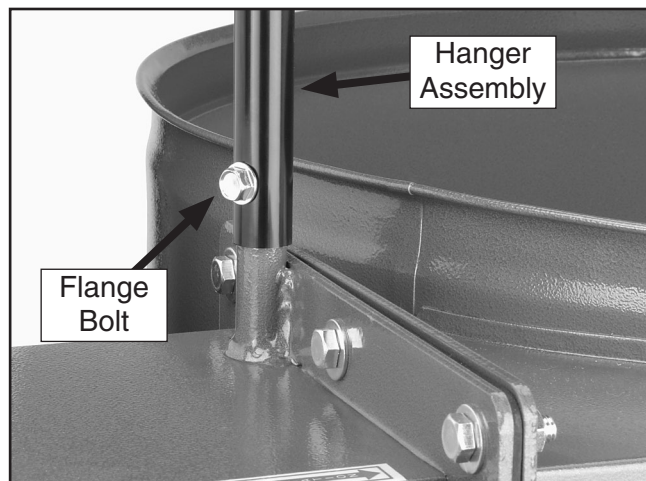

Figure 12. Hanger assembly mounted onto collector.

20. Align the hanger assembly so that the hook at the top is directly over the center of the collector.
21. Secure the hanger assembly with one $\frac{1}{4}$ "-20 x $\frac{1}{2}$ " flange bolt (see **Figure 12**).
22. Repeat **Steps 18–22** for the remaining hanger assemblies.
23. Place the loop at the top of the upper collection bag over the top hook of the hanger assembly (see **Figure 13**).

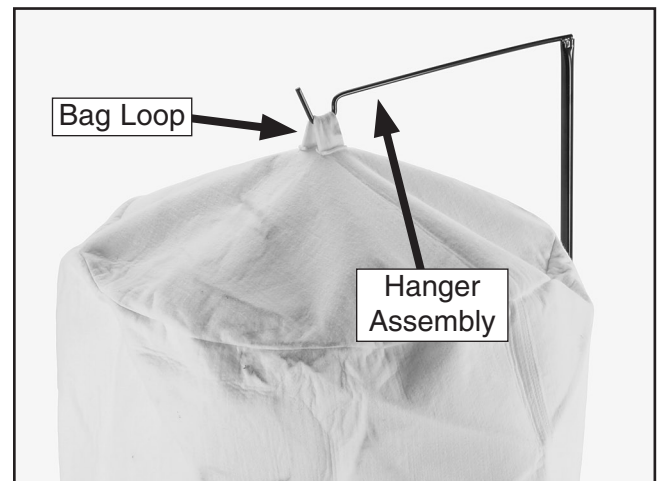

Figure 13. Upper filter bag mounted on hanger assembly.

24. Thread the bag clamp into and around the bottom seam of the upper collection bag (see **Figure 14**).



Figure 14. Upper filter bag secured to collector.

25. Slip the bottom of the bag over the top lip of the collector so that the bag clamp is completely over the lip as well.
26. Fasten the locking mechanism of the bag clamp to secure the bag to the collector (see **Figure 14**).
27. Slip the lower collection bag over the bottom lip of the collector and position the bag evenly around the collector.
28. Snag the bag on the hooks to hold the bag in place until the bag clamp can be secured (see **Figure 15**).

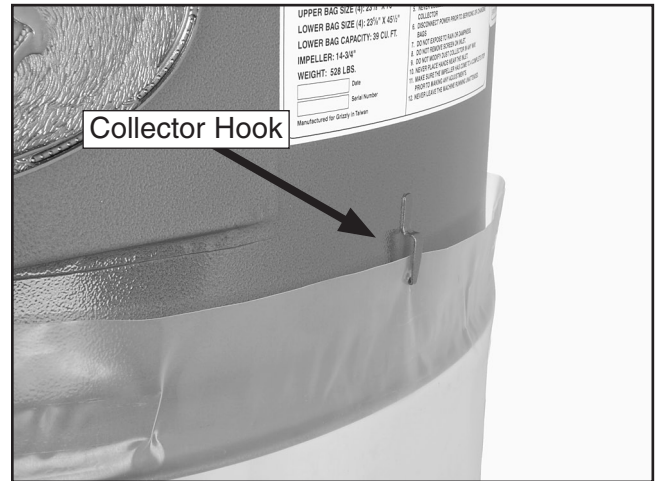

Figure 15. Bottom collection bag snagged on collector hooks.

29. Wrap the bag clamp around the collector and position it between the bottom lip of the collector and the hooks, fasten the bag clamp to secure the bag to the collector (see **Figure 16**).

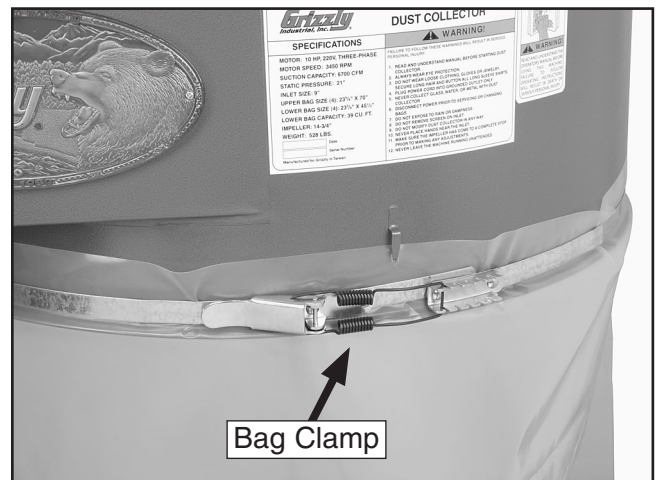
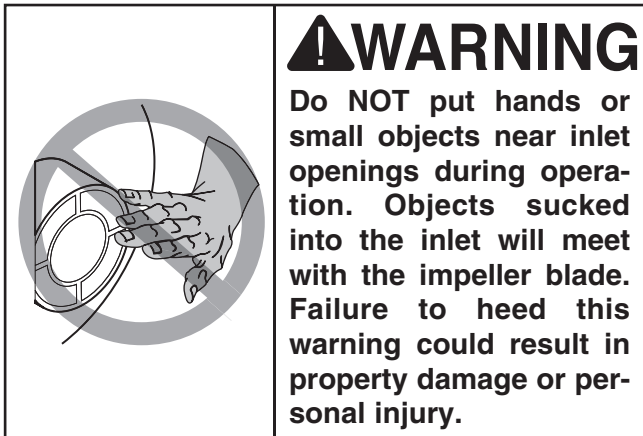

Figure 16. Lower collection bag secured to collector.

Test Run



Once assembly is complete, test run your machine to make sure it runs properly.

To test run the dust collector:

1. Make sure you have read and understand all of the safety instructions starting on **Page 6** of this manual, and make sure the machine is set up properly.

2. Connect the dust collector to the proper power source (reference **Circuit Requirements** on **Page 9**).
3. Clear away from the machine all tools and objects used during the setup.
4. Turn the machine **ON** by pushing in the GREEN button on the power switch.
5. Listen and watch for abnormal noises or operation. The machine should run smoothly with little or no vibration or rubbing noises.

—Strange or unusual noises **MUST** be investigated and corrected before operating the machine further. Always disconnect the machine from power before investigating or correcting potential problems.

—If you cannot easily locate the source of a potential problem, refer to **Troubleshooting** on **Page 30** or contact our Technical Support at (570) 546-9663.

6. Turn **OFF** the machine by pushing in the RED button on the power switch.



SECTION 4: DESIGNING THE SYSTEM

General

The Model G0508 can be operated as either a stationary or mobile unit. There are advantages and disadvantages to both set-ups. The advantage of the mobile system is eliminating the cost of many ducts and fittings. On the other hand, the stationary system is more versatile and convenient.

The Model G0508 is designed to be a central dust collector system. Locate the dust collector in an out of the way location such as a corner or separate room. The dust collector is capable of collecting dust from up to eight machines running simultaneously. The large suction capacity of the Model G0508 allows great flexibility in planning and designing of your dust collection duct layout. Grizzly offers a complete line of dust collection accessories for setting up a stationary system. Additionally, Grizzly offers a complete guide book titled *Dust Collection Basics*.

A 5-port inlet is included with the Model G0508 for quick and economical dust collection setup. However, depending upon your system design using this feature, bags may fill at different rates requiring you to empty some bags more often than others.

Whatever system you choose, always make sure there are no open flames (including pilot lights) in the same room as the dust collector; otherwise you risk an explosion if dust is dispersed into the air.

Duct Material

You have many choices regarding main line and branch line duct material. For best results, use metal duct for the main line and branch lines, then use a short lengths of flexible hose to connect each machine to the branch lines.

Plastic duct is also a popular material for home shops. However, be aware that there is a fire or explosion hazard if plastic duct material is used for dust collection without being grounded against static electrical charge build-up. This topic will be discussed later in this section. Another problem with using plastic is that it is less efficient per foot than metal.

Metal Duct

Advantages of metal duct is its conductivity and that it does not contribute to static electrical charge build-up. However, static charges are still produced when dust particles strike other dust particles as they move through the duct. Since metal duct is a conductor, it can be grounded quite easily to dissipate any static electrical charges.

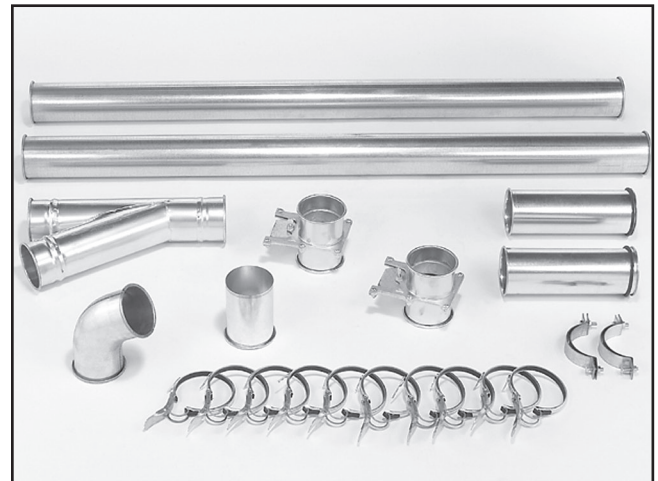

Figure 17. Examples of metal pipe and components.

There are quite a number of options when it comes to metal duct, but metal duct that is specially manufactured for dust collection is the best choice. When selecting your metal duct, choose high quality metal duct with smooth welded internal seams that will minimize airflow resistance. This type of duct usually connects to other ducts or elbows with a simple, self-sealing clamp, is very quick and easy to assemble, and can be readily dismantled and re-installed. This is especially important if you ever need to change things around in your shop or add more tools. See the **Accessories** section on **Page 25** for examples.

Avoid inferior metal duct that requires you to cut it to length and snap it together. This type of duct is time consuming to install because it requires you to seal all the seams with silicone and screw the components on the ends with sheet metal screws. Another disadvantage is the rough internal seams and crimped ends that unavoidably increase static pressure loss.

Flexible Duct

Flexible hose is generally used for short runs, small shops and at rigid duct-to-tool connections. There are many different types of flex hose on the market today. These are manufactured from materials such as polyethylene, PVC, cloth hose dipped in rubber and even metal, including steel and aluminum.

The superior choice for flexible ducting is metal flex hose that is designed to be flexible and as smooth as possible to reduce static pressure loss.

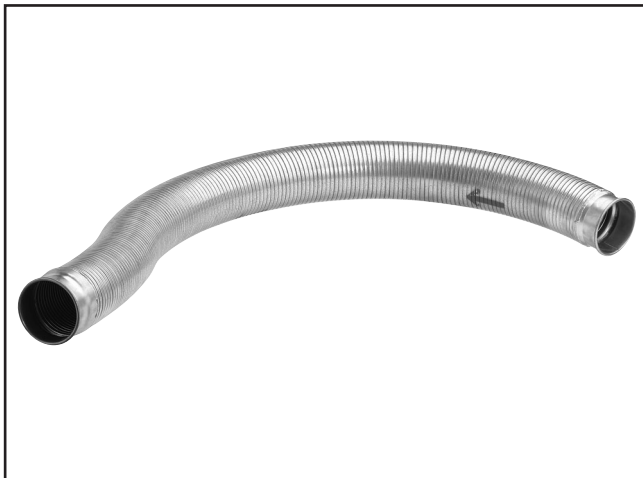

Figure 18. Example of flexible metal duct.

There are also many kinds of pure plastic flexible hose, such as non-perforated drainage type hose and dryer vent hose. Drainage type hose, while being economical, does not quite have the flexibility required for dust collection. The inside of the duct is also deeply corrugated and can increase the static pressure loss by as much as 50% over smooth wall duct. Dryer vent hose offers greater flexibility, but is non-resistant to abrasion and tends to collapse in a negative pressure system. We **DO NOT** recommend using dryer vent hose in your dust collection system.

If using flex-hose, choose one of the many types designed specifically for the movement of solid particles, i.e. dust, grains and plastics. However, the cost of specifically designed flexible duct can vary greatly. Grizzly offers polyethylene hose, which is well suited for the removal of particulate matter, especially sawdust, since it is durable and completely flexible. Polyethylene is also very economical and available in a wide variety of diameters and lengths for most applications.

Plastic Duct

The popularity of plastic duct is due to the fact that it is economical and readily available. It is also simple to assemble and easily sealed against air loss. The primary disadvantage of plastic duct for dust collection is the inherent danger of static electrical build-up.



Figure 19. Example of plastic duct and components.

System Design

Step 1. Decide Who Will Design

For most small-to-medium sized shops, you can design and build the dust collection system yourself without hiring engineers or consultants. We have included some basic information here to get you started on a dust collection system design.

If you have a large shop or must design a complicated system, then we recommend additional research beyond this manual, or seek help from an expert.

Step 2. Sketch Your Shop Layout

Planning is the most important step when designing a successful dust collection system.

Before you begin to draw your necessary layout sketch, we recommend that you visit our **FREE Workshop Planner** available on our website at www.grizzly.com.

Our *Workshop Planner* will allow you to quickly and easily draw and print a basic shop layout. Don't worry, non-Grizzly brand machines can be substituted with Grizzly machines for layout purposes. **Note:** After you're finished, make sure to save your layout for later modification.

Your sketch only needs the basic details of the shop layout, similar to **Figure 20**, including all your current/planned machines and your planned placement of the dust collector.

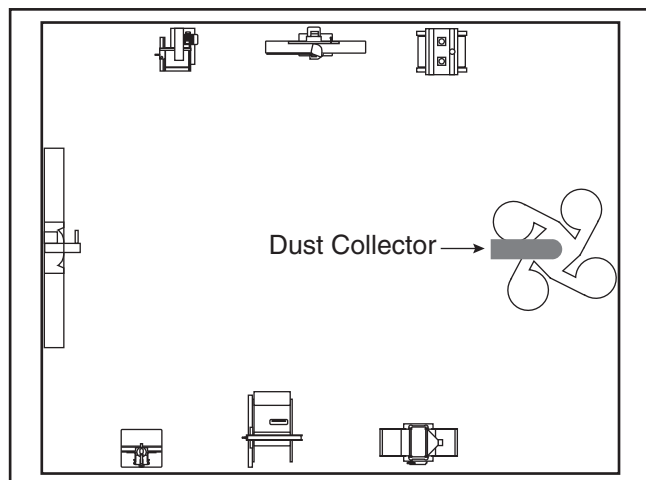

Figure 20. Initial sketch of shop layout.

Step 3. Sketch a Basic Duct Layout

For the next step, sketch how your machines will connect to the dust collector. Consider these general guidelines for planning an efficient system:

1. Machines that produce the most sawdust should be placed nearest to the dust collector (i.e. planers and sanders).
2. An ideal design will feature the shortest possible main line and secondary branch ducts. See **Figures 21 & 22** for ideas of good duct layouts vs bad duct layouts.

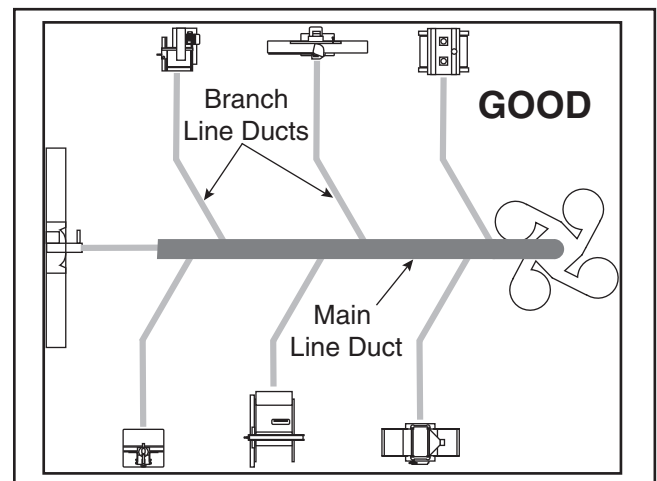

Figure 21. Good duct layout.

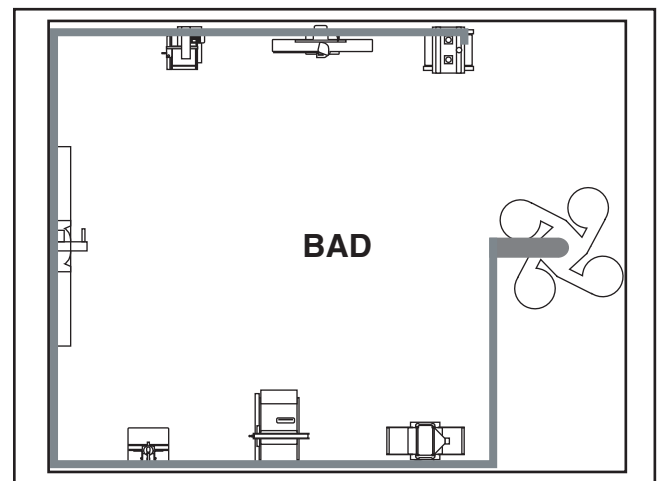

Figure 22. Bad duct layout.

3. Directional changes should be kept to a minimum. The more directional change fittings you use directly increases the overall resistance to airflow.
4. Gradual directional changes are more efficient than sudden directional changes (i.e. use the largest corner radius possible when changing hose or pipe direction).
5. Each branch line should have a blast gate immediately after the branch to control suction from one machine to another.
6. The simpler the system, the more efficient and less costly it will be.

Step 4. Determine Required CFM of Each Machine

Since each machine produces a different amount of sawdust, the requirements for the minimum amount of CFM needed to move that sawdust is unique to the machine (for example, a planer produces more sawdust than a table saw). Knowing this required CFM is important in gauging which size of duct to use.

Figure 23 will give you a close estimation of the airflow your machine requires. Machines that generate the most sawdust should be placed near the dust collector. If the machine has multiple dust ports, the total CFM required is the sum of all ports.

Machine Dust Port Size	Approximate Required CFM
2"	98
2.5"	150
3"	220
4"	395
5"	614
6"	884
7"	1203
8"	1570
9"	1990
10"	2456

Figure 23. Approximate required airflow for machines, based on dust port size.

If your machine does not have a built in dust port, use **Figure 24** to determine the size of dust port to install on your machine.

Machine	Average Dust Port Size
Table Saw	4"
Miter/Radial-Arm Saw	2"
Jointer (6" and smaller)	4"
Jointer (8"-12")	5"
Thickness Planer (13" and smaller)	4"
Thickness Planer (14"-20").....	6"
Shaper	4"
Router (mounted to table)	2"
Bandsaw.....	4"
Lathe.....	4"
Disc Sander (12" and smaller)	2"
Disc Sander (13-18").....	4"
Belt Sander (6" and smaller)	2"
Belt Sander (7"-9")	3"
Edge Sander (6" x 80" and smaller).....	4"
Edge Sander (6" x 80" and larger)	5"
Drum Sander (24" and smaller)	2 x 4"
Drum Sander (24" and larger).....	4 x 4"
Widebelt Sander (18" and smaller)	5"
Widebelt Sander (24"-37" single head) ..	2 x 6"
Widebelt Sander (24" _51" double head) ..	.5 x 4"

Figure 24. Dust port size and quantity per average machine.

Write the required CFM for each machine on your sketch, as shown in **Figure 25**.

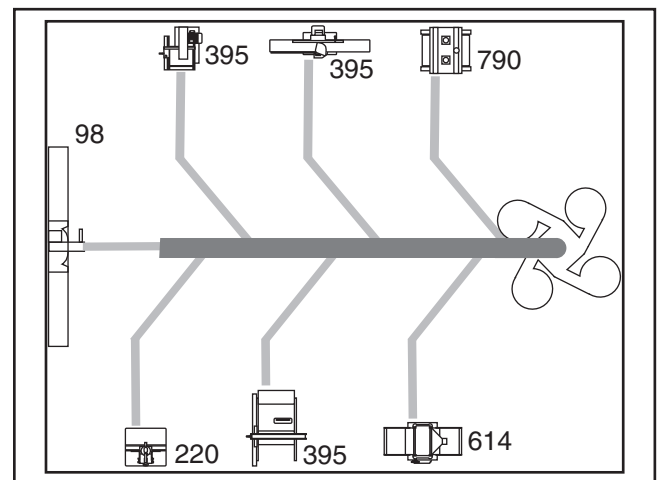

Figure 25. CFM requirements labeled for each machine.



Determining Main Line Duct Size

The general rule of thumb for a main line duct is that the *velocity* of the airflow must not fall below 3500 FPM.

For small/medium sized shops, using the inlet size of the dust collector as the main line duct size will usually keep the air velocity above 3500 FPM and, depending on your system, will allow you to keep multiple branches open at one time.

For the Model G0508 this is 9". Mark your drawing as in **Figure 26**.

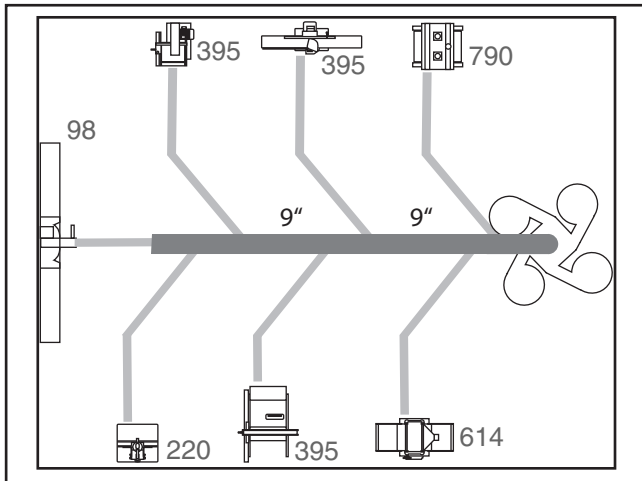

Figure 26. Main line size labeled on sketch.

Determining Branch Line Duct Size

The general rule of thumb for a branch line duct is that the *velocity* of the airflow must not fall below 4000 FPM.

For small/medium sized shops, using the dust port size from the machine as the branch line duct size will achieve the correct velocity in most applications. However, if the dust port on the machine is smaller than 4", make the branch line 4" and neck the line down right before the dust port.

Note: *Systems with powerful dust collectors work better if multiple blast gates are left open. This also allows you to run two machines at once. Experiment with different combinations of blast gates open/closed to find the best results for your system.*

Write your determined branch line sizes on your drawing, as shown in **Figure 27**.

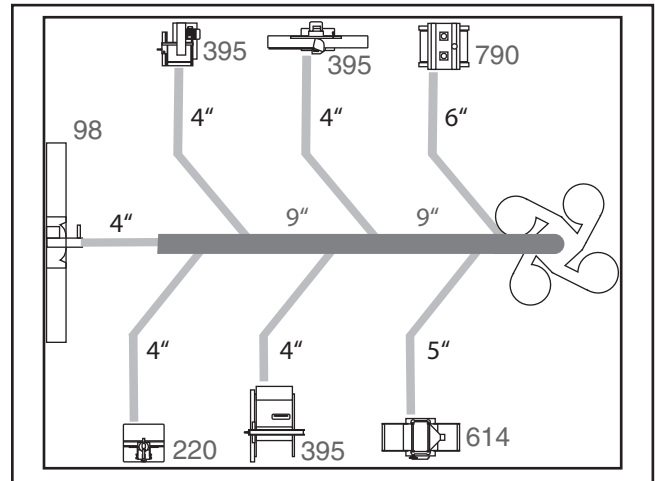

Figure 27. Branch line sizes labeled on sketch.

A few frequently asked questions when determining branch line sizes:

What size of branch line do I use if the machine has two dust ports?

Simply add the total CFM given for each size from **Figure 23** and refer to that CFM number in **Figure 28**. Then, split the branch line just before the dust ports with matching duct sizes.

How do I manage two machines on the same branch line?

You have two options:

1. If both machines will be running at the same time, add the total CFM given for each size from **Figure 23** and match the branch line given in **Figure 28**.
2. If both the machines will never be run at the same time, reference the machine with biggest dust port in **Figure 28** and add blast gates after the Y-branch to open/close the line to each machine.

Total CFM	Branch Line Size
600	5"
700	5"
800	6"
1000	6"
1200	7"
1400	8"
1600	8"

Figure 28. Branch line sizing chart by total CFM (for use when multiple machines share line).

Calculating Duct Resistance

Adding duct work, elbows, branches and any other components to a duct line increases airflow resistance (static pressure loss). This resistance can be minimized by using rigid (smooth) pipe and gradual curves, as opposed to flexible pipe and 90° elbows.

To help you think about this resistance, imagine riding a bicycle in a tunnel that is an exact replica of your duct work. If the inside of the tunnel is very bumpy (flexible pipe) and has many sharp turns (90° elbows), it will take a lot more effort for you to travel from one end to the other than if your path had been smooth and straight.

The purpose of calculating this resistance is to determine if it is low enough from the machine to the dust collector to meet the given requirement for the machine. Use the charts in **Figure 29** to calculate the resistance of duct work.

Duct Dia.	Approximate Static Pressure Loss Per Foot of Rigid Pipe		Approximate Static Pressure Loss Per Foot of Flex Pipe	
	Main Lines at 3500 FPM	Branch Lines at 4000 FPM	Main Lines at 3500 FPM	Branch Lines at 4000 FPM
2"	0.091	0.122	0.35	0.453
2.5"	0.08	0.107	0.306	0.397
3"	0.071	0.094	0.271	0.352
4"	0.057	0.075	0.215	0.28
5"	0.046	0.059	0.172	0.225
6"	0.037	0.047	0.136	0.18
7"	0.029	0.036	0.106	0.141
8"	0.023	0.027	0.08	0.108
9"	0.017	0.019	0.057	0.079

Fitting Dia.	90° Elbow	45° Elbow	45° Wye(Y)	90° Wye(Y)
3"	0.47	0.235	0.282	0.188
4"	0.45	0.225	0.375	0.225
5"	0.531	0.266	0.354	0.236
6"	0.564	0.282	0.329	0.235
7"	0.468	0.234	0.324	0.216
8"	0.405	0.203	0.297	0.189

Figure 29. Static pressure loss charts.

In most small/medium shops it is only necessary to calculate FPM for the line with the longest duct length or the most fittings (operating under the assumption that if the line with the highest resistance works, the others will be fine).

To calculate the static pressure loss of any given line in the system, follow these steps:

1. Make a list of each size duct in the line, including the length, and multiply those numbers by the static pressure loss value given in **Figure 29**.
2. List each type of elbow or branch and multiply the quantity (if more than one) by the static pressure loss given in **Figure 29**.
3. Add the additional factors from **Figure 30** to your list.

Additional Factors	Static Pressure Loss
Seasoned (well used) Dust Collection Filter	1
Entry Loss at Large Machine Hood	2

Figure 30. Additional factors affecting static pressure loss.

4. Total your list as shown in the example in **Figure 31** to come up with your overall static pressure loss number for that line.

Note: Always account for a seasoned filter, so you don't end up with a system that only works right when the filter is clean.

Main Line	
6" Rigid Pipe (.037) at 20'	.740
Branch Line	
4" Rigid Pipe (.075) at 10'	.750
4" Flex Pipe (.28) at 5'	1.400
Elbows/Branches	
6" 45° Y-Branch	.329
4" 45° Elbow	.225
Additional Factors	
Seasoned Filter	1.000
Total Static Pressure	4.444

Figure 31. Example list for totaling SP loss.



Note: When calculating static pressure loss to determine if multiple lines can be left open at the same time, only include the main line numbers once.

5. Compare the total static pressure loss for that line to the maximum static pressure rating of 21 inches (refer to the **Machine Data Sheet** on **Page 3**).

—If your static pressure loss is below the static pressure rating of the dust collector, then the line will most likely be successful. Congratulations! You've just designed your own dust system. Refer to the **Accessories** section on **Page 25** to start buying the components necessary to make your system a reality.

—If your static pressure loss is equal to or above the static pressure rating of the dust collector, then that line will not effectively collect the dust. You must then modify some of the factors in that line to reduce the static pressure loss. Some of the ways to do this include 1) installing larger duct, 2) reducing amount of flexible duct used, 3) increasing machine dust port size, 4) moving machine closer to dust collector to eliminate duct length, and 5) reducing 90° elbows or replacing them with 45° elbows.

System Grounding

Since plastic hose is abundant, relatively inexpensive, easily assembled and air tight, it is a very popular material for conveying dust from woodworking machines to the dust collector. We recommend using flexible hose (flex-hose) to connect the woodworking machine to the dust collection system. However, plastic flex-hose and plastic duct are insulators, and dust particles moving against the walls of the plastic duct create static electrical build up. This charge will build until it discharges to a ground. If a grounding medium is not available to prevent static electrical build up, the electrical charge will arc to the nearest grounded source. This electrical discharge may cause an explosion and subsequent fire inside the system.

To protect against static electrical build up inside a non-conducting duct, a bare copper wire should be placed inside the duct along its length and grounded to the dust collector. You must also confirm that the dust collector is continuously grounded through the electrical circuit to the electric service panel.

If you connect the dust collector to more than one machine by way of a non-conducting branching duct system and blast gates, the system must still be grounded as mentioned above. We recommend inserting a continuous bare copper ground wire inside the entire duct system and attaching the wire to each grounded woodworking machine and dust collector.

Be sure that you extend the bare copper wire down all branches of the system. Do not forget to connect the wires to each other with wire nuts when two branches meet at a “Y” or “T” connection.



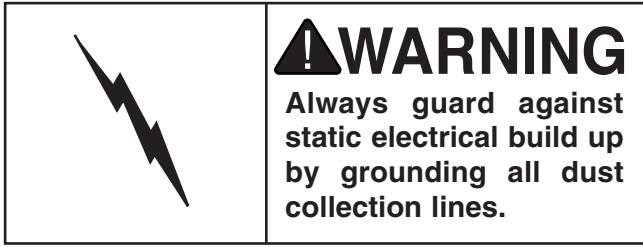

Ensure that the entire system is grounded. If using plastic blast gates to direct air flow, the grounding wire must be jumped (**Figure 32**) around the blast gate without interruption to the grounding system.

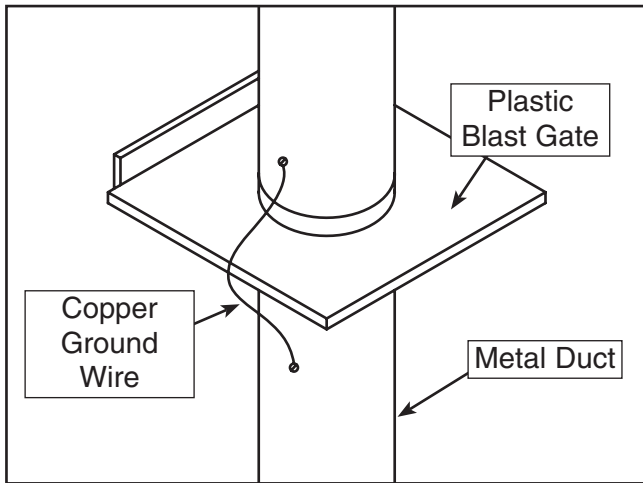

Figure 32. Ground jumper wire when using plastic blast gates and metal duct.

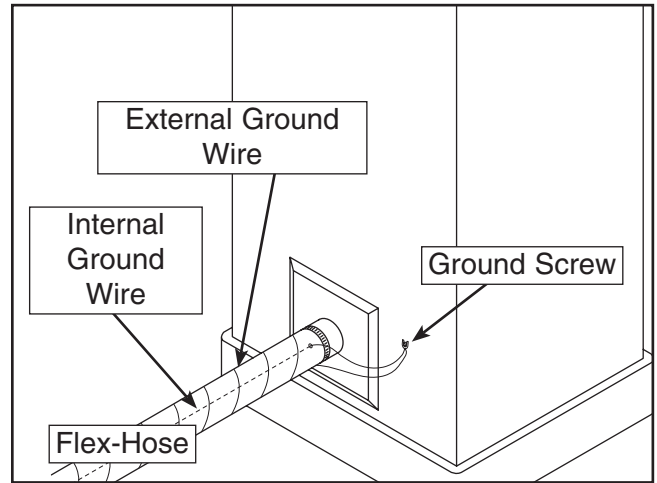

Figure 33. Flex-hose grounded to machine.

We also recommend wrapping the outside of all plastic ducts with bare copper wire to ground the outside of the system against static electrical build up. Wire connections at Y's and T's should be made with wire nuts.

Attach the bare ground wire to each stationary woodworking machine and attach to the dust collector frame with a ground screw as shown in **Figure 33**. Ensure that each machine is continuously grounded to the grounding terminal in your electric service panel.



SECTION 5: ACCESSORIES

H5293—4" Metal Duct Starter Kit

H5295—5" Metal Duct Starter Kit

H5297—6" Metal Duct Starter Kit

Save over 20% with this great starter kit. Includes: (2) machine adapters, (10) pipe clamps, (3) 5' straight pipes, (1) branch, (3) pipe hangers, (1) end cap, (3) adjustable nipples, (1) 90° elbow, and (1) 60° elbow.

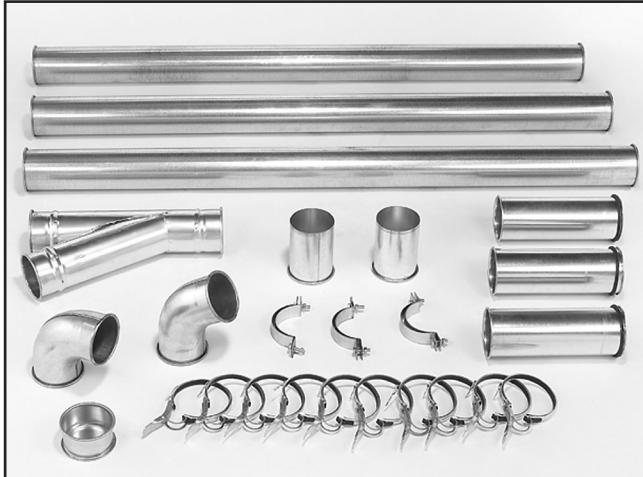

Figure 34. Metal Duct Starter Kit.

H5294—4" Metal Duct Machine Addition Kit

H5296—5" Metal Duct Machine Addition Kit

H5298—6" Metal Duct Machine Addition Kit

Save over 20% with this great machine addition kit. Includes: (2) blast gates, (1) machine adapter, (10) pipe clamps, (2) pipe hangers, (2) 5' straight pipes, (2) adjustable nipples, (1) branch, and (1) 60° elbow.

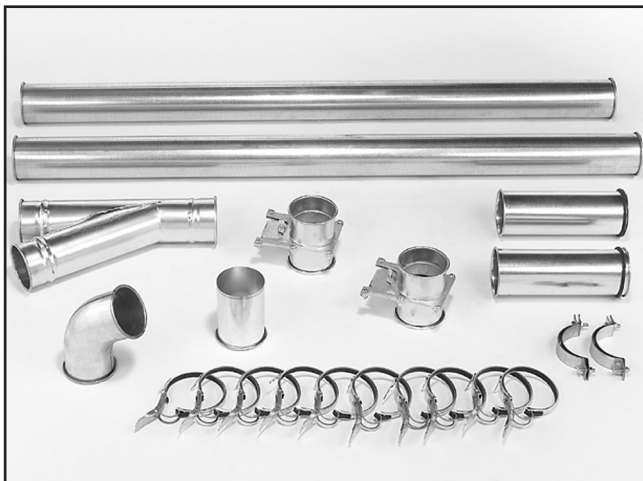

Figure 35. Metal Duct Machine Addition Kit.

G6162—4" x 5' Straight Metal Pipe

G7346—5" x 5' Straight Metal Pipe

G7364—6" x 5' Straight Metal Pipe

H5227—7" x 5' Straight Metal Pipe

H5237—8" x 5' Straight Metal Pipe

H5252—9" x 5' Straight Metal Pipe

These laser welded straight pipes ensure a super smooth internal seam. Ends easily clamp together for a sealed fit without screws or silicone.

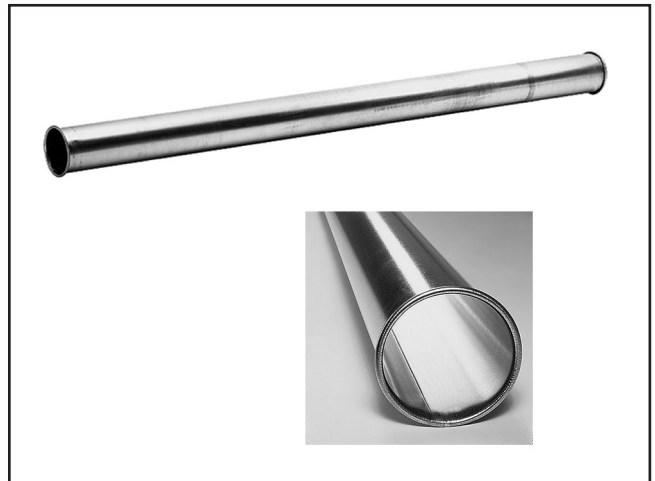

Figure 36. Straight Metal Pipe.

H7216—5" x 5' Rigid Metal Flex Hose

H7217—6" x 5' Rigid Metal Flex Hose

H7218—7" x 5' Rigid Metal Flex Hose

H7219—8" x 5' Rigid Metal Flex Hose

H7220—9" x 5' Rigid Metal Flex Hose

This flex hose provides just enough flexibility to make difficult connections while still keeping the inside wall as smooth as possible to minimize static pressure loss.

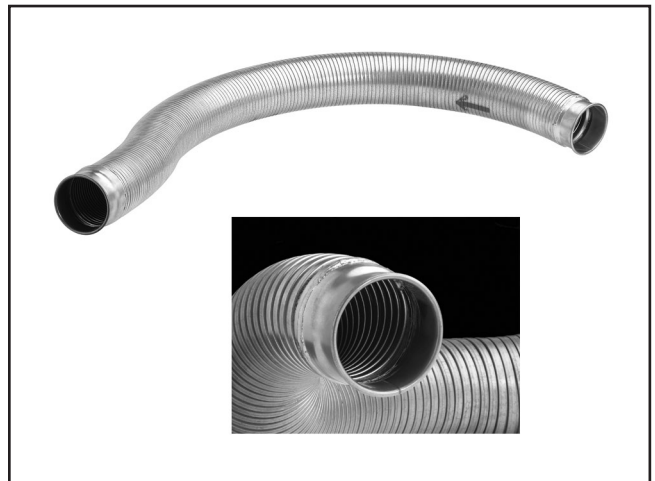

Figure 37. Rigid Metal Flex Hose.

Metal Elbows

These industrial metal elbows are available from 4"–8" with 90°, 60°, 45°, or 30° curves. Also, available with a 90° long radius curve. Call (800) 523-4777 or visit www.grizzly.com for more information and pricing.

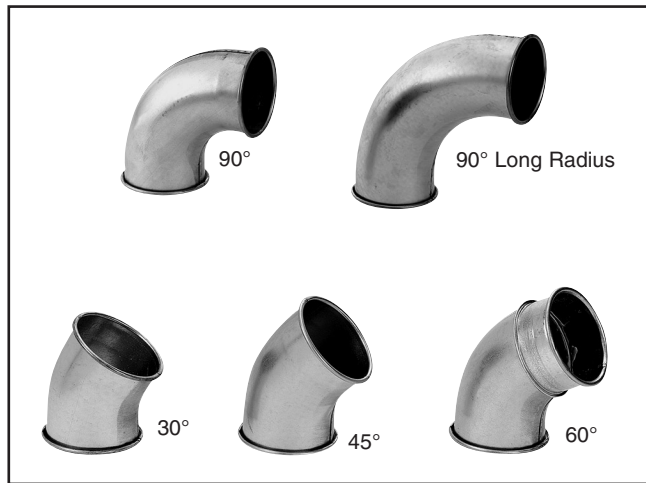

Figure 38. Metal elbow examples.

- G6177—4" Metal Blast Gate
- G7340—5" Metal Blast Gate
- G7358—6" Metal Blast Gate
- H5234—7" Metal Blast Gate
- H5249—8" Metal Blast Gate
- H5259—9" Metal Blast Gate



Figure 39. Metal Blast Gate.

Call 1-800-523-4777 To Order

Metal Branches

We carry many different branches, all designed to minimize airflow resistance.

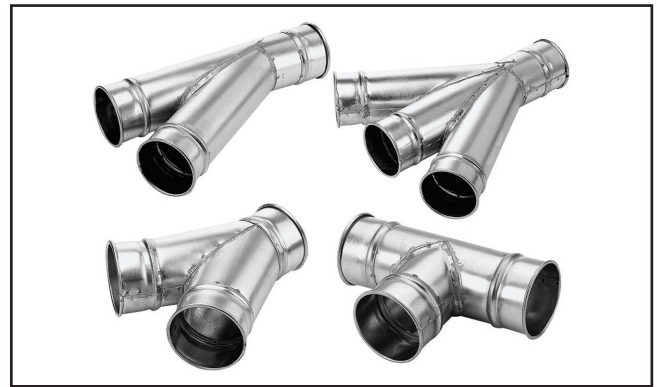

Figure 40. Metal Branches.

Reducers & Adapters

We carry a multitude of reducers and elbows to cover most applications from 4" through 9".



Figure 41. Metal Reducers & Adapters.

- G6252—4" Floor Sweep
- G7341—5" Floor Sweep
- G7342—6" Floor Sweep

Great for cleaning up around the shop, these metal floor sweeps close tight when not in use.



Figure 42. Industrial Floor Sweep.



- G6163—4" Clamp**
- G7343—5" Clamp**
- G7361—6" Clamp**
- H5228—7" Clamp**
- H5238—8" Clamp**
- H5253—9" Clamp**

These clamps feature lever latches and foam seals, and secure around the rolled ends of fittings and pipe.



Figure 43. Dust collection pipe clamps.

- G2752—4" Rolling Floor Sweep**
- G2753—4" Bench Dust Collection Attachment**
- G2754—4" Floor Dust Collection Attachment**

These attachments are indispensable for collecting dust at machines without a port. The rolling floor sweep is also a convenient way to keep the shop floor or workbench top clean! Designed for use with 4" flexible hose (not included).



Figure 44. Dust collection attachments.

H2443—Universal Adapter

This seven step adapter provides a multitude of dust collection reducing options. Simply cut away unneeded steps with a hacksaw. Outside diameter step sizes include 1", 2", 2.5", 3", 4", 5", and 6". Wall thickness is 1/8".

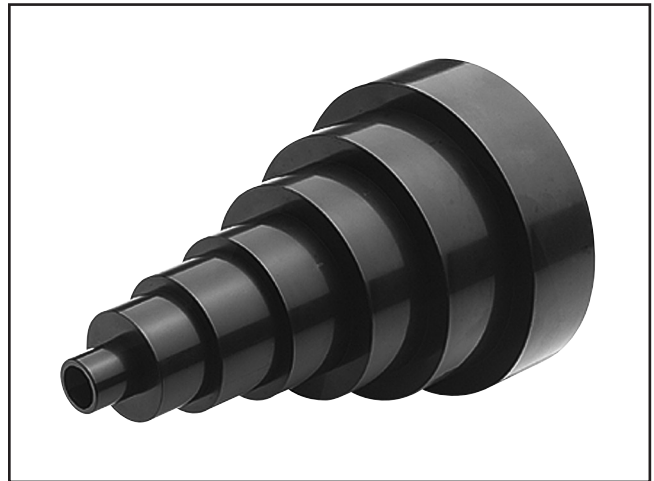

Figure 45. H2443 Universal Adapter.

G0572—Hanging Air Cleaner w/Remote

Unfortunately, not even the best dust collection systems get all the dust. This is why it is extremely important to have one or two air cleaners to claim the fine dust suspended in the air. This model features a convenient remote control, three speeds, an automatic shutoff timer, and a 2-stage filter system (5 micron outer and 1 micron inner). Easily the best value in its class!



Figure 46. G0572 Hanging Air Cleaner.

Call 1-800-523-4777 To Order



SECTION 6: OPERATIONS



⚠️ CAUTION
DO NOT use the dust collector for any other purpose besides collecting dust from connected woodworking machines. A dust collector should NEVER be used as a shop vacuum. For safest use, wear a respirator and use an air cleaner in addition to the dust collector.

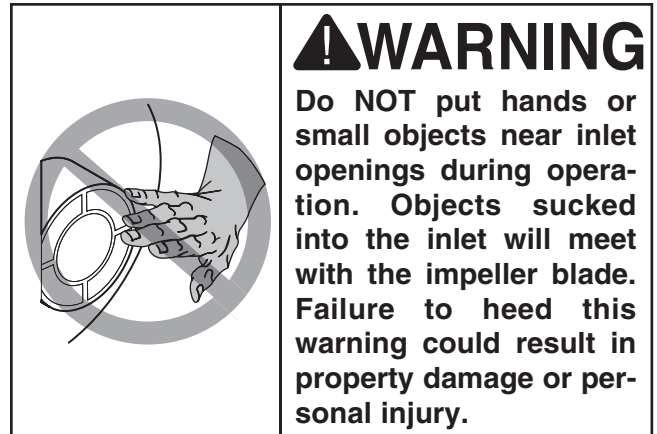
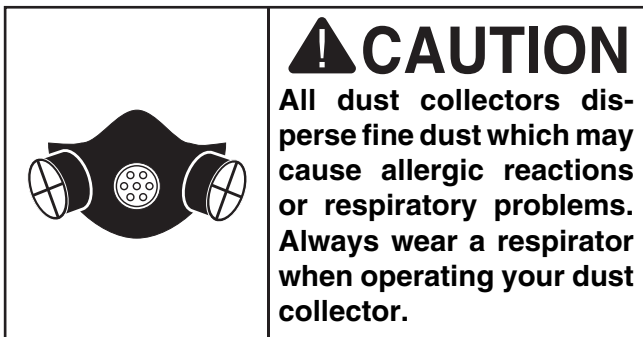

General

Operating your Model G0508 is simple and straightforward. Blast gates located at each of the machines controls the air flow from the woodworking machine to the dust collector. If a machine is not being used, keep the blast gate closed to maintain higher levels of efficiency throughout the system.



SECTION 7: MAINTENANCE

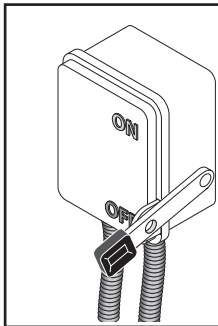

⚠️ WARNING

Disconnect power to the machine when performing any maintenance, assembly or adjustments. Failure to do this may result in serious personal injury.

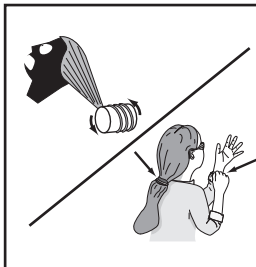

⚠️ WARNING

Keep loose clothing rolled up and out of the way of machinery and keep hair pulled back.

Schedule

For optimum performance from your machine, follow this maintenance schedule and refer to any specific instructions given in this section.

Daily Check:

- Dust collector is completely powered down at the end of use.
- Loose mounting bolts.
- Worn switch or wires.
- Any other condition that would hamper the safe operation of this machine.
- Empty the lower collection bags before they become completely full.

Lubrication

Since all bearings are shielded and permanently lubricated, simply leave them alone until they need to be replaced. Do not lubricate them.

Bag Cleaning

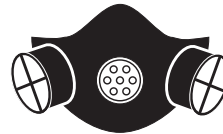

⚠️ CAUTION

All dust collectors disperse fine dust which may cause allergic reactions or respiratory problems. Always wear a respirator when operating your dust collector.

Empty the lower collection bags on a regular basis to maintain dust collection efficiency.

Always wear the appropriate respirator or dust mask and safety glasses when emptying the collection bags. Small dust particles can escape the bags during emptying, causing them to become airborne and easily inhaled. This microscopic airborne dust is extremely unhealthy to breathe and can cause serious health problems.

While the Model G0508 excels at collecting the majority of wood dust produced by your machines, we always recommend the supplemental aid of a shop air filter such as the Grizzly G5955, G9956, or G0572 (see **Page 27**). Air filters are designed to collect the smaller dust particles that a dust collector bags cannot trap.



SECTION 8: SERVICE

About Service

This section is provided for your convenience—it is not a substitute for the Grizzly Service Department. If you need help troubleshooting, need replacement parts, or are unsure of how to perform the procedures in this section, please call our Technical Support at (570) 546-9663.

Troubleshooting

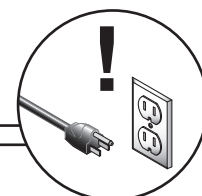

Motor & Machine Operation

SYMPTOM	POSSIBLE CAUSE	CORRECTIVE ACTION
Machine does not start or a breaker trips.	<ol style="list-style-type: none"> 1. Plug/receptacle is at fault or wired incorrectly. 2. Motor connection wired incorrectly. 3. Thermal overload relay has tripped. 4. Contactor not getting energized/ has burnt contacts. 5. Power supply is at fault/switched OFF. 6. Motor ON button or ON/OFF switch is at fault. 7. Centrifugal Switch is at fault. 8. Wiring is open/has high resistance. 9. Motor is at fault. 10. Start delay module is at fault. 	<ol style="list-style-type: none"> 1. Test for good contacts; correct the wiring. 2. Correct motor wiring connections. 3. Turn cut-out dial to increase working amps and push the reset pin. Replace if tripped multiple times (weak relay). 4. Test for power on all legs and contactor operation. Replace unit if faulty. 5. Ensure hot lines have correct voltage on all legs and main power supply is switched ON. 6. Replace faulty ON button or ON/OFF switch. 7. Adjust/replace the centrifugal switch if available. 8. Check for broken wires or disconnected/corroded connections, and repair/replace as necessary. 9. Test/repair/replace. 10. Adjust to correct delay; replace module.
Machine stalls or is underpowered.	<ol style="list-style-type: none"> 1. Motor connection is wired incorrectly. 2. Plug/receptacle is at fault. 3. Motor bearings are at fault. 4. Motor has overheated. 5. Contactor not getting energized or has poor contacts. 6. Motor is at fault. 7. Centrifugal switch is at fault. 	<ol style="list-style-type: none"> 1. Correct motor wiring connections. 2. Test for good contacts; correct the wiring. 3. Test by rotating shaft; rotational grinding/loose shaft requires bearing replacement. 4. Clean off motor, let cool, and reduce workload. 5. Test for power on all legs and contactor operation. Replace if faulty. 6. Test/repair/replace. 7. Adjust/replace centrifugal switch if available.
Machine has vibration or noisy operation.	<ol style="list-style-type: none"> 1. Motor or component is loose. 2. Motor fan is rubbing on fan cover. 3. Cast iron motor mount loose/ broken. 4. Motor bearings are at fault. 5. Centrifugal switch. 	<ol style="list-style-type: none"> 1. Inspect/replace stripped or damaged bolts/nuts, and re-tighten with thread locking fluid. 2. Replace dented fan cover; replace loose/damaged fan. 3. Tighten/replace. 4. Test by rotating shaft; rotational grinding/loose shaft requires bearing replacement. 5. Replace



Dust Collection Operation

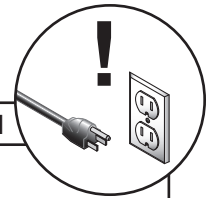

SYMPTOM	POSSIBLE CAUSE	CORRECTIVE ACTION
Loud, repetitious noise, or excessive vibration coming from dust collector.	<ol style="list-style-type: none"> 1. Dust collector is not on a flat surface and wobbles. 2. Impeller fan is damaged and unbalanced. 3. The motor mounting is loose. 4. Impeller is loose on the motor shaft. 5. Motor fan cover is dented, causing the motor fan to hit the cover while spinning. 	<ol style="list-style-type: none"> 1. Stabilize the dust collector. 2. Unplug dust collector, and inspect the impeller for dents, bends, loose fins. Replace impeller if any damage is found. 3. Make sure all fasteners on the dust collector are tight. 4. Replace the motor and impeller as a set if the motor shaft and the impeller hub is damaged. 5. Replace motor fan cover.
Dust collector does not adequately collect dust or chips; poor performance.	<ol style="list-style-type: none"> 1. Dust collection bag is full. 2. There is a restriction in the duct line. 3. The dust collector is too far away from the point of suction, or there are too many sharp bends in the ducting. 4. The lumber is wet and not flowing through the dust lines smoothly. 5. There is a leak in the ducting, or a series of small leaks, or too many open ports. 6. There are not enough open branch lines at one time, thereby causing a velocity drop in the main line. 7. The ducting and ports are incorrectly sized. 8. The machine dust collection design is inadequate. 9. The dust collector is too small for the dust collection system. 	<ol style="list-style-type: none"> 1. Empty collection bag. 2. Remove dust line from dust collector inlet and unblock the restriction in the duct line. A plumbing snake may be necessary. 3. Relocate the dust collector closer to the point of suction, and rework ducting without sharp bends. Refer to Designing the System, beginning on Page 17. 4. Process lumber with less than 20% moisture content. 5. Rework the ducting to eliminate all leaks. Close dust ports for lines not being used. Refer to Designing the System on Page 17 for more solutions. 6. Open 1 or 2 more blast gates to different branch lines to allow the velocity in the main line to increase. 7. Reinstall correctly sized ducts and fittings. Refer to Designing the System on Page 17 for more solutions. 8. Use a dust collection nozzle on a stand. 9. Install a larger dust collector to power your dust collection system.
Sawdust being blown into the air from the dust collector.	<ol style="list-style-type: none"> 1. Bag clamps, dust collection bag, or filter bag is not properly secured. 	<ol style="list-style-type: none"> 1. Reclamp the dust collection bag and air filter bag, making sure bag clamps are tight and completely over the bags.



Electrical Components

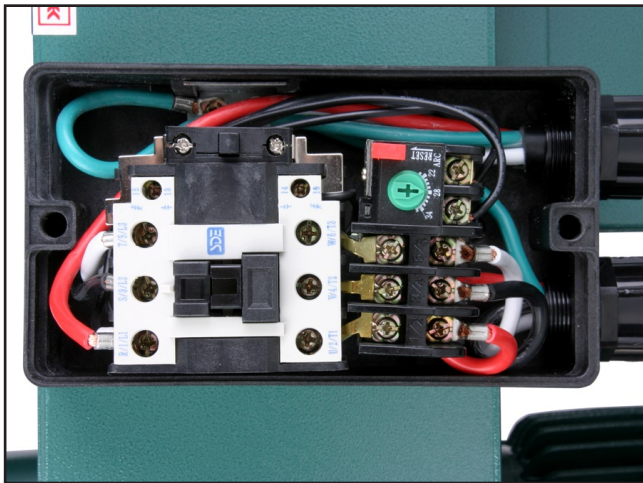

Figure 47. G0508 220V switch.

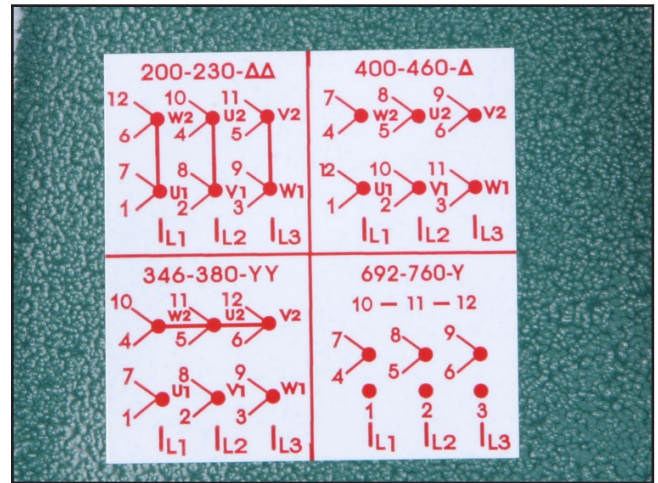

Figure 48. G0508 motor wiring diagrams.



Figure 49. G0508 220V motor.



Wiring Diagram



G0508

COLOR KEY	
BLACK	
GREEN	
RED	
WHITE	

⚠ DANGER

Disconnect power before performing any electrical service. Electricity presents serious shock hazards that will result in severe personal injury and even death!

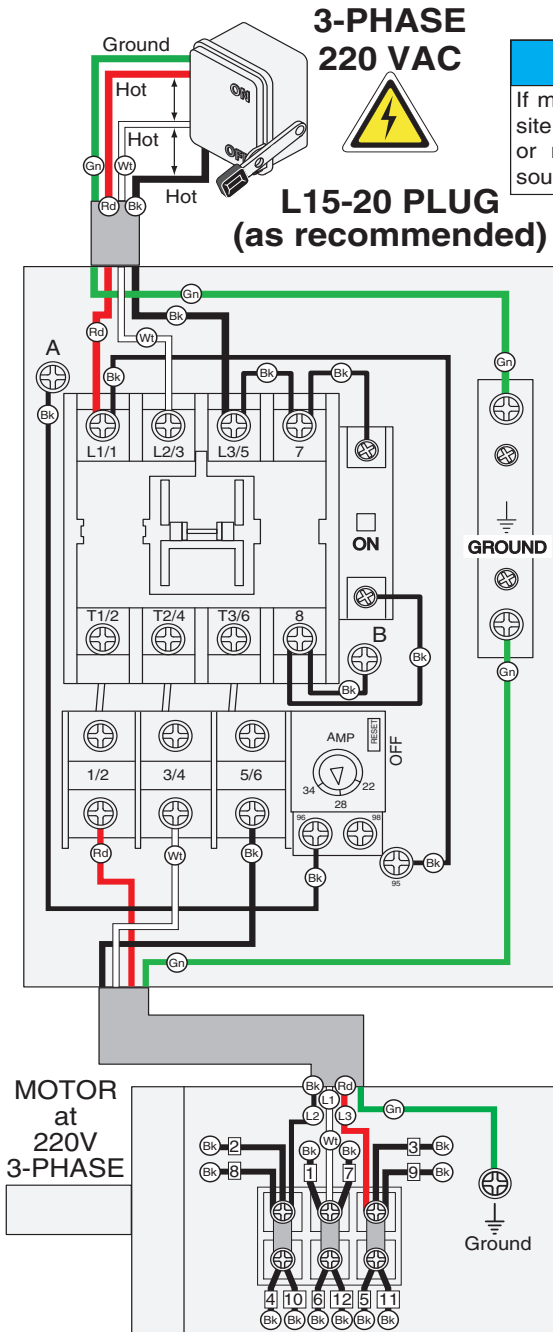

NOTICE

If motor rotates in the opposite direction, swap the black or red wires at the power source.

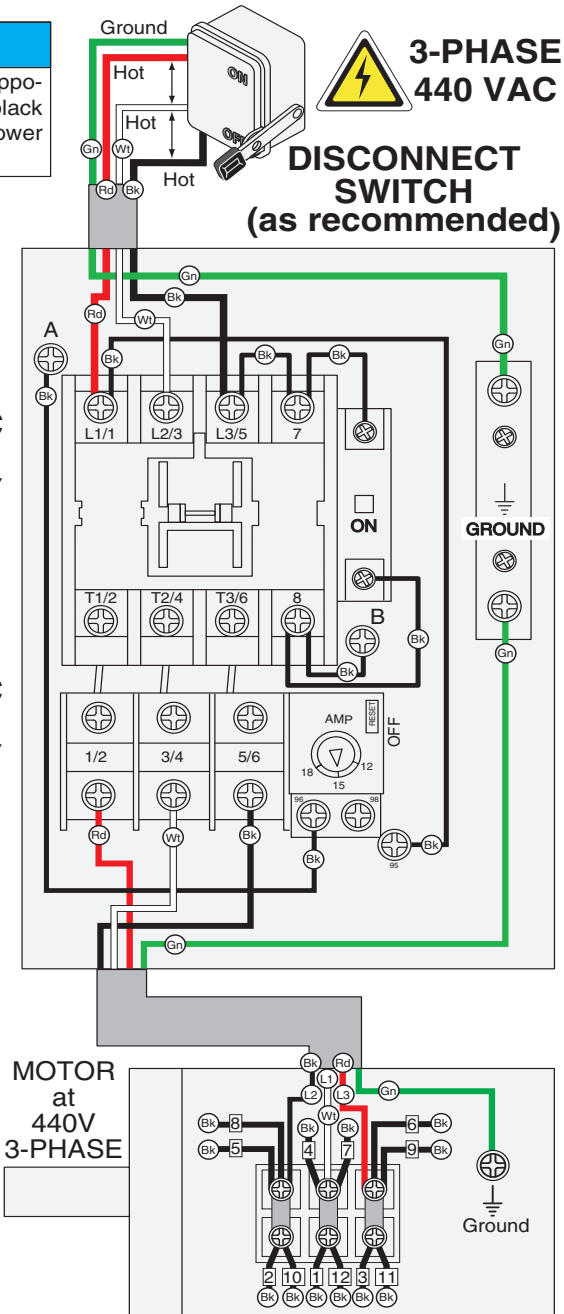

Parts Breakdown

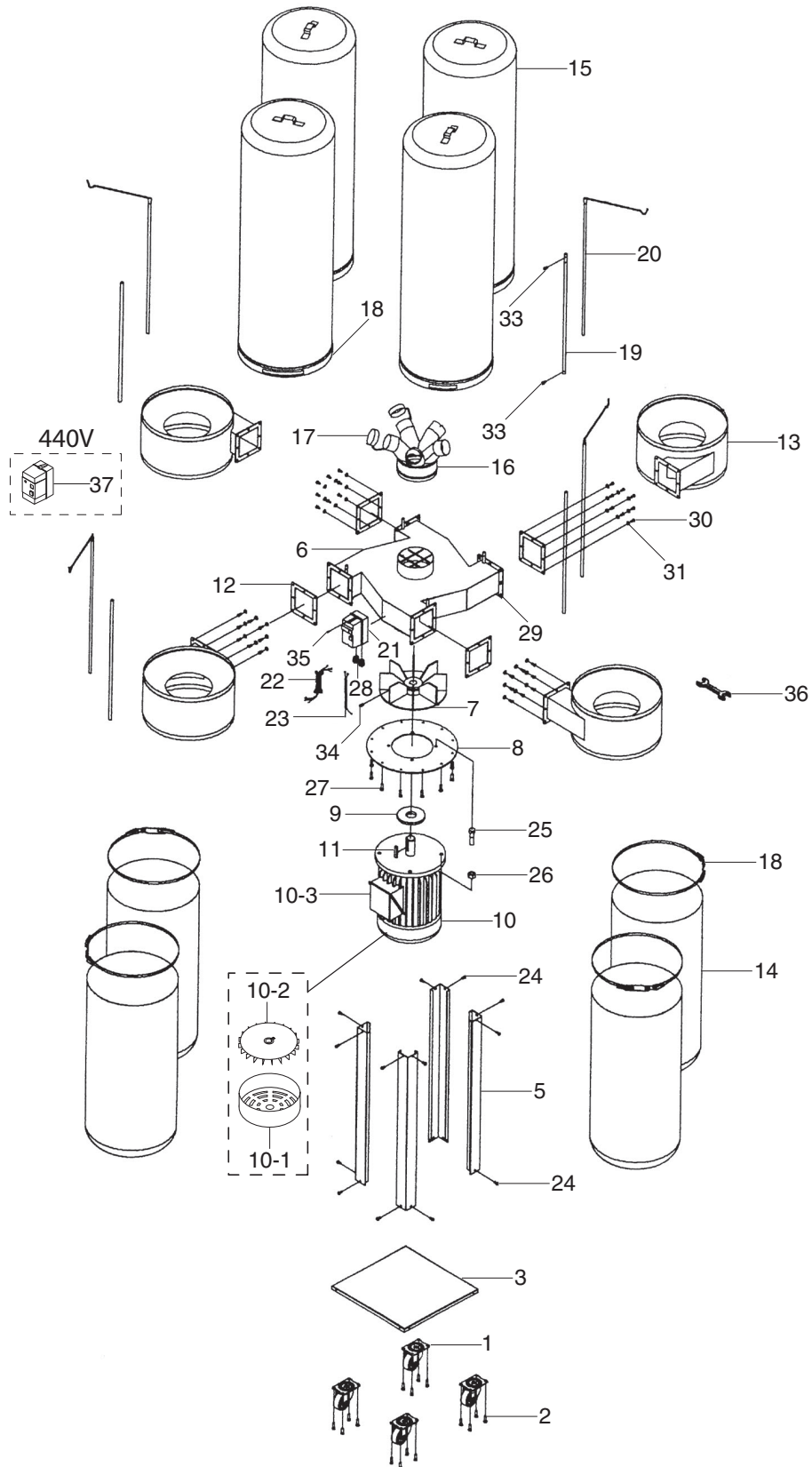

Parts List

REF	PART #	DESCRIPTION
1	P5954001	CASTER
2	PB09	HEX BOLT 5/16-18 X 1/2
3	P0508003	BASE
5	P0508005	SUPPORTING LEG
6	P0508006	MAIN HOUSING
7	P0508007	IMPELLER
8	P0508008	MOTOR PLATE
9	P0508009	SPECIAL WASHER
10	P0508010	MOTOR
10-1	P0508010-1	MOTOR FAN COVER
10-2	P0508010-2	MOTOR FAN
10-3	P0508010-3	MOTOR JUNCTION BOX
11	P0508011	KEY 10 X 8 X 50
12	P0508012	RUBBER GASKET
13	P0508013	COLLECTOR
14	P5954023	LOWER COLLECTION BAG
15	P0508015	UPPER FILTER BAG
16	P0508016	INLET
17	P0508017	INLET COVER

REF	PART #	DESCRIPTION
18	P0508018	BAG CLAMP
19	P0508019	HANGER SUPPORT
20	P0508020	HANGER
21	P0508021	SWITCH 220VAC 3-P
22	P0508022	POWER CORD
23	P0508023	MOTOR CORD
24	PB09	HEX BOLT 5/16-18 X 1/2
25	PB55	HEX BOLT 1/2-13 X 1-1/2
26	PN13	HEX NUT 1/2-13
27	PB07	HEX BOLT 5/16-18 X 3/4
28	P0508028	STRAIN RELIEF
29	PN02	HEX NUT 5/16-18
30	PB03	HEX BOLT 5/16-18 X 1
31	PW07	FLAT WASHER 5/16
33	PB19	HEX BOLT 1/4-20 X 1/2
34	PB24	HEX BOLT 3/8-16 X 1-1/4
35	PS12	PHLP HD SCR 1/4-20 x 5/8
36	PWR1012	COMBO WRENCH 10/12MM
37	P0508037	440V CONVERSION KIT



Label Placement

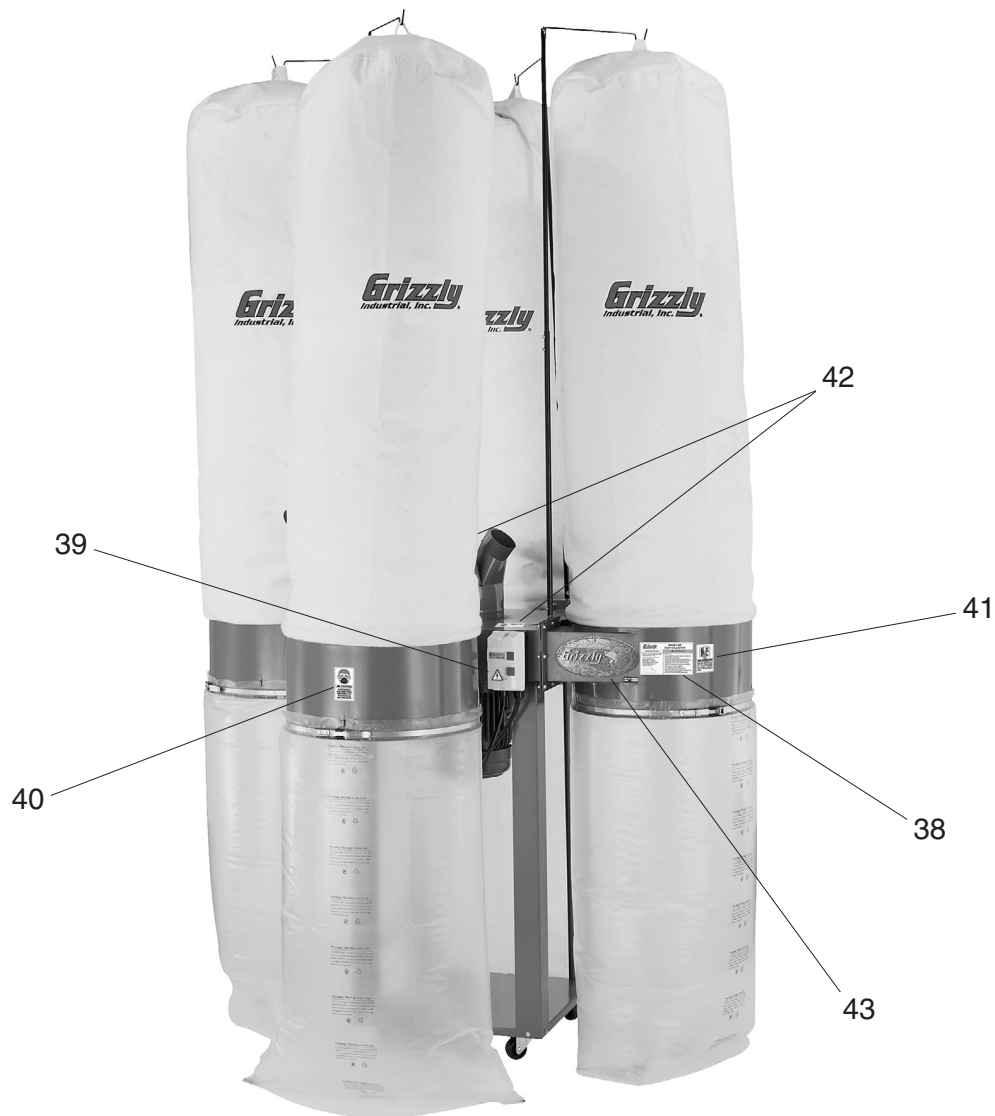

REF	PART #	DESCRIPTION
38	P05080038	MACHINE ID LABEL
39	PLABEL-14	ELECTRICITY LABEL
40	P05080040	DUST MASK LABEL

REF	PART #	DESCRIPTION
41	PLABEL-12	READ MANUAL
42	P05080042	NO HANDS AT INLET LABEL
43	PLABEL-8	GRIZZLY LOGO

WARNING

Safety labels warn about machine hazards and ways to prevent injury. The owner of this machine **MUST** maintain the original location and readability of the labels on the machine. If any label is removed or becomes unreadable, **REPLACE** that label before using the machine again. Contact Grizzly at (800) 523-4777 or www.grizzly.com to order new labels.



WARRANTY AND RETURNS

Grizzly Industrial, Inc. warrants every product it sells for a period of **1 year** to the original purchaser from the date of purchase. This warranty does not apply to defects due directly or indirectly to misuse, abuse, negligence, accidents, repairs or alterations or lack of maintenance. This is Grizzly's sole written warranty and any and all warranties that may be implied by law, including any merchantability or fitness, for any particular purpose, are hereby limited to the duration of this written warranty. We do not warrant or represent that the merchandise complies with the provisions of any law or acts unless the manufacturer so warrants. In no event shall Grizzly's liability under this warranty exceed the purchase price paid for the product and any legal actions brought against Grizzly shall be tried in the State of Washington, County of Whatcom.

We shall in no event be liable for death, injuries to persons or property or for incidental, contingent, special, or consequential damages arising from the use of our products.

To take advantage of this warranty, contact us by mail or phone and give us all the details. We will then issue you a "Return Number," which must be clearly posted on the outside as well as the inside of the carton. We will not accept any item back without this number. Proof of purchase must accompany the merchandise.

The manufacturers reserve the right to change specifications at any time because they constantly strive to achieve better quality equipment. We make every effort to ensure that our products meet high quality and durability standards and we hope you never need to use this warranty.

Please feel free to write or call us if you have any questions about the machine or the manual.

Thank you again for your business and continued support. We hope to serve you again soon.





WARRANTY CARD

Name _____

Street _____

City _____ State _____ Zip _____

Phone # _____ Email _____ Invoice # _____

Model # _____ Order # _____ Serial # _____

The following information is given on a voluntary basis. It will be used for marketing purposes to help us develop better products and services. **Of course, all information is strictly confidential.**

1. How did you learn about us?

- Advertisement
- Card Deck
- Friend
- Website
- Catalog
- Other:

2. Which of the following magazines do you subscribe to?

- | | | |
|---|--|---|
| <input type="checkbox"/> Cabinet Maker | <input type="checkbox"/> Popular Mechanics | <input type="checkbox"/> Today's Homeowner |
| <input type="checkbox"/> Family Handyman | <input type="checkbox"/> Popular Science | <input type="checkbox"/> Wood |
| <input type="checkbox"/> Hand Loader | <input type="checkbox"/> Popular Woodworking | <input type="checkbox"/> Wooden Boat |
| <input type="checkbox"/> Handy | <input type="checkbox"/> Practical Homeowner | <input type="checkbox"/> Woodshop News |
| <input type="checkbox"/> Home Shop Machinist | <input type="checkbox"/> Precision Shooter | <input type="checkbox"/> Woodsmith |
| <input type="checkbox"/> Journal of Light Cont. | <input type="checkbox"/> Projects in Metal | <input type="checkbox"/> Woodwork |
| <input type="checkbox"/> Live Steam | <input type="checkbox"/> RC Modeler | <input type="checkbox"/> Woodworker West |
| <input type="checkbox"/> Model Airplane News | <input type="checkbox"/> Rifle | <input type="checkbox"/> Woodworker's Journal |
| <input type="checkbox"/> Modeltec | <input type="checkbox"/> Shop Notes | <input type="checkbox"/> Other: |
| <input type="checkbox"/> Old House Journal | <input type="checkbox"/> Shotgun News | |

3. What is your annual household income?

- \$20,000-\$29,000
- \$30,000-\$39,000
- \$40,000-\$49,000
- \$50,000-\$59,000
- \$60,000-\$69,000
- \$70,000+

4. What is your age group?

- 20-29
- 30-39
- 40-49
- 50-59
- 60-69
- 70+

5. How long have you been a woodworker/metalworker?

- 0-2 Years
- 2-8 Years
- 8-20 Years
- 20+ Years

6. How many of your machines or tools are Grizzly?

- 0-2
- 3-5
- 6-9
- 10+

7. Do you think your machine represents a good value? Yes No

8. Would you recommend Grizzly Industrial to a friend? Yes No

9. Would you allow us to use your name as a reference for Grizzly customers in your area?
Note: We never use names more than 3 times. Yes No

10. Comments: _____

CUT ALONG DOTTED LINE

FOLD ALONG DOTTED LINE



Place
Stamp
Here



GRIZZLY INDUSTRIAL, INC.
P.O. BOX 2069
BELLINGHAM, WA 98227-2069



FOLD ALONG DOTTED LINE

Send a Grizzly Catalog to a friend:

Name _____
Street _____
City _____ State _____ Zip _____

TAPE ALONG EDGES--PLEASE DO NOT STAPLE

grizzly.com

TOOL WEBSITE

Buy Direct and Save with Grizzly® – Trusted, Proven and a Great Value!

*Visit Our Website Today And Discover
Why Grizzly® Is The Industry Leader!*

- SECURE ORDERING
- ORDERS SHIPPED WITHIN 24 HOURS
- E-MAIL RESPONSE WITHIN ONE HOUR

-OR-

Call Today For A **FREE**
Full Color Catalog

1-800-523-4777



Free Manuals Download Website

<http://myh66.com>

<http://usermanuals.us>

<http://www.somanuals.com>

<http://www.4manuals.cc>

<http://www.manual-lib.com>

<http://www.404manual.com>

<http://www.luxmanual.com>

<http://aubethermostatmanual.com>

Golf course search by state

<http://golfingnear.com>

Email search by domain

<http://emailbydomain.com>

Auto manuals search

<http://auto.somanuals.com>

TV manuals search

<http://tv.somanuals.com>