



MODEL H8110 9 DRAWER EURO STYLE WORKBENCH-BIRCH INSTRUCTIONS

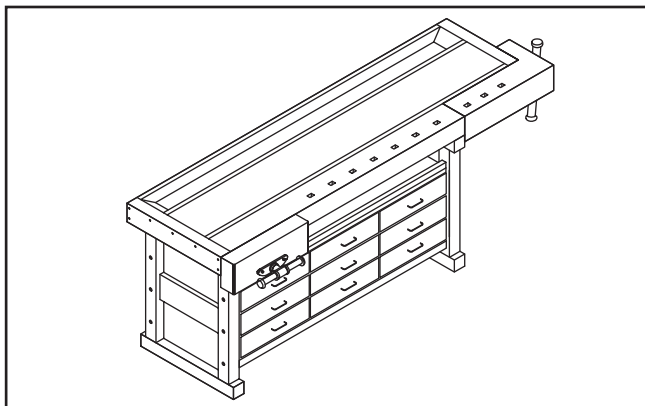

Figure 11. Model H8110 Birch Workbench.

Specifications

Finish	Lacquer Sealed
Drawer Slides	Ball Bearing
Number of Drawers	9
Front Vise Size	19 ³ / ₄ " x 7"
End Vise Size	6" x 6"
Overall Size	84 ¹ / ₂ "W x 24 ¹¹ / ₁₆ "D x 34 ¹ / ₄ "H
Drawer Size	15 ³ / ₈ "W x 13 ⁷ / ₈ "D x 4"H
Storage Shelf Size.....	55 ¹ / ₂ "W x 18 ¹ / ₂ "D
Shipping Weight	367 lbs.

Safety & Limitations

- Maximum workbench table load is 500 lbs.
- Do not stand or climb on the workbench.
- Do not apply an unbalanced load on the table that could result in the workbench tipping.
- Keep unsupervised children away from the workbench.
- Do not stand or climb on the workbench.
- Do not use workbench outdoors or in wet or damp locations.
- Do not overload the vises or use cheater pipes on the vise handles to increase leverage.
- Do not weld on this bench.

Assembly

Refer to the last page of these instructions to inventory your shipment for ease of assembly.

To assemble the workbench:

1. Position the right side leg (C) on the floor so the UP arrow is pointing upward and the FRONT arrow points to the front, as shown in Figure 12.
2. Place the two lower cross braces (E) on the floor so the slots face each other, as shown in Figure 12.

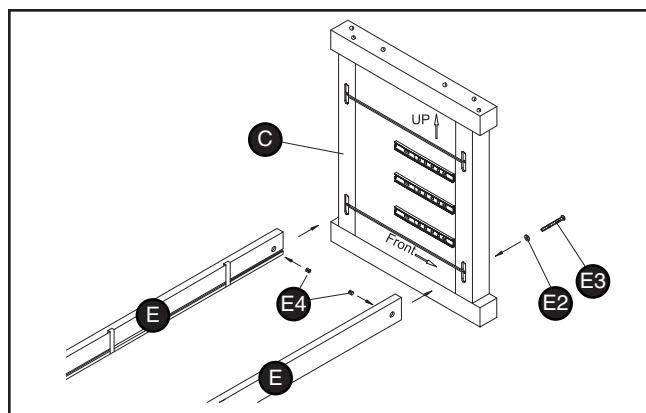

Figure 12. Right leg and cross brace installation.

3. Insert the barrel nuts (E4) (Figure 12) into the ends of the cross braces so the slotted end faces outward and the screwdriver slots are aligned horizontally with the direction of the cross braces.
4. Insert the cross braces into the mortised holes into the right-side leg, as shown in Figure 12.

COPYRIGHT © JULY 2009 BY GRIZZLY INDUSTRIAL, INC.

WARNING: NO PORTION OF THIS MANUAL MAY BE REPRODUCED IN ANY SHAPE OR FORM WITHOUT THE WRITTEN APPROVAL OF GRIZZLY INDUSTRIAL, INC.
(FOR MODELS MANUFACTURED SINCE 7/09) #CR12018 PRINTED IN CHINA

5. Place a flat washer (E2) on each barrel bolt (E3), and insert the bolts through the right-side leg (Figure 12).
6. Using a 5mm hex wrench, thread the bolts into the barrel nuts (E4) (Figure 12), but do not fully tighten at this time.
7. Insert the lower panel (F) into the slots of the two lower cross braces (E), and into the groove of the side leg (Figure 13).

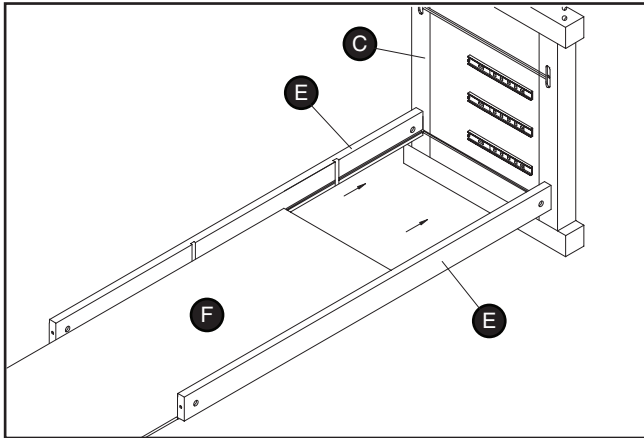

Figure 13. Lower panel installation.

8. Insert both central drawer support panels (H) (Figure 14) into the cross brace (E) slots.

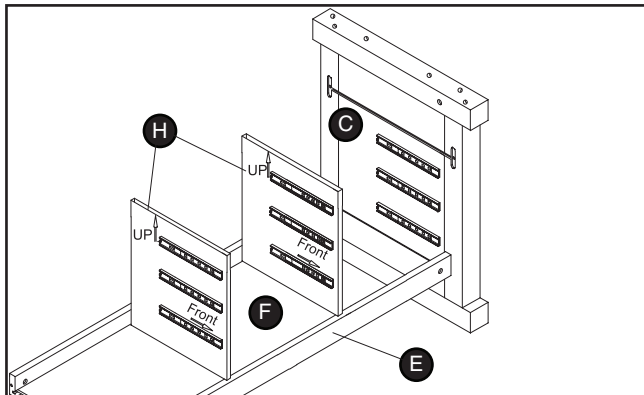

Figure 14. Drawer support installation.

9. Install the two upper cross braces (D) (Figure 15) into leg (C) with the same hardware and methods covered in Steps 1-7. Do not fully tighten the hardware yet.

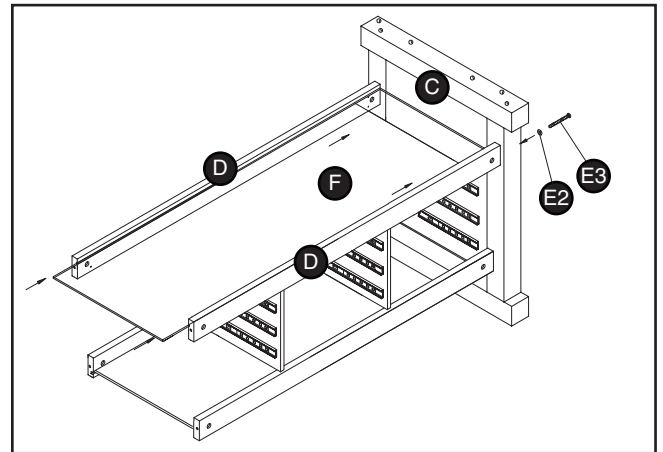

Figure 15. Upper cross panel installation.

10. Insert the upper panel (F) into the slot of the two upper cross braces (D) and into the groove of the side leg (Figure 15).
11. Insert the remaining four barrel nuts (E4) (Figure 16) into the other end of the previously installed cross braces.

Make sure that the slotted end of the barrel nuts face outward and the screwdriver slots are aligned horizontally with the direction of the cross braces.

12. Position the left side leg (B) on the floor so the UP arrow is pointing upward and the FRONT arrow points to the front as shown in Figure 16.

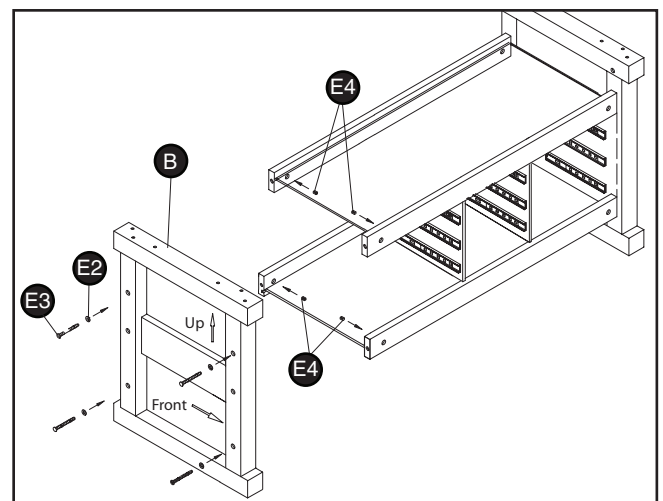

Figure 16. Left leg installation.

13. Carefully engage the slots in the left leg with the cross supports and panels, and place a flat washer (E2) on each remaining barrel bolt (E3) (Figure 16).



14. Insert the bolts through the left-side leg, tighten with a 5mm hex wrench, and all other barrel bolts at this time.
15. Align the pre-drilled holes in the underside of the work bench table top (A) with the pre-drilled holes in the legs.
16. Place a flat washer (E2) onto each of the four 2" wood screws (E8). From the table underside, insert the screws in the pre-drilled holes, and use a 4mm hex wrench to tighten the wood screws.
17. Using a standard screwdriver, attach the right (SR) and left (SL) drawer sides to the drawer backs (SB). Then slide the drawer bottoms (BP) into the drawer side grooves (**Figure 17**) until they are fully seated in the grooves.

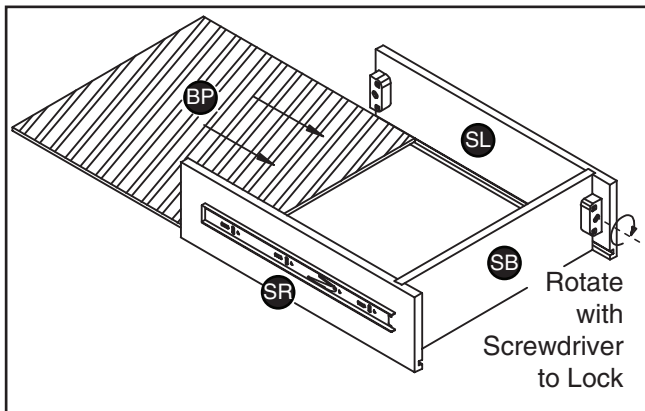

Figure 17. Initial drawer assembly.

18. Install the drawer fronts (SF) (**Figure 18**), the handles (E5), the screws (E1), and insert the drawers into the work bench drawer slides.

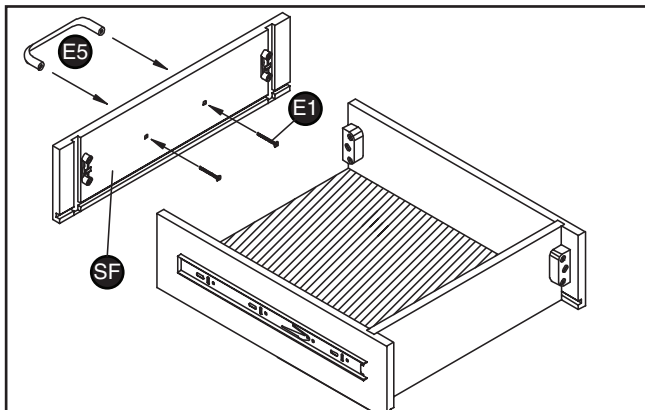

Figure 18. Final drawer assembly.

19. Insert the guide rods and leadscrew through the holes in the wood block (G) (**Figure 19**). Thread the leadscrew into the vise support until the wood block is slightly snug against the table and flush with the table top.

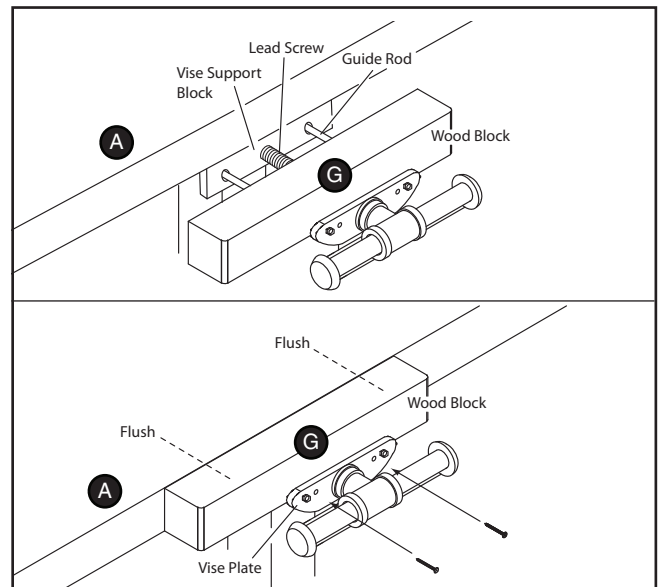

Figure 19. Table vise installation.

20. Keeping the wood block flush with the table top (**Figure 19**), drill two $\frac{5}{64}$ " holes $1\frac{7}{16}$ " deep through the vise plate mounting holes and into the wood block.
21. Secure the vise plate to the wood block with two (E10) #5 x $1\frac{7}{16}$ " wood screws (**Figure 19**). Install a cotter pin in the end of the lead-screw, and bend one pin leg to 90 degrees.
22. Insert the tail vise wood block into the vise support block (**Figure 20**). Insert the tail vise leadscrew through the holes in the wood block and the vise support block at the edge of the table.

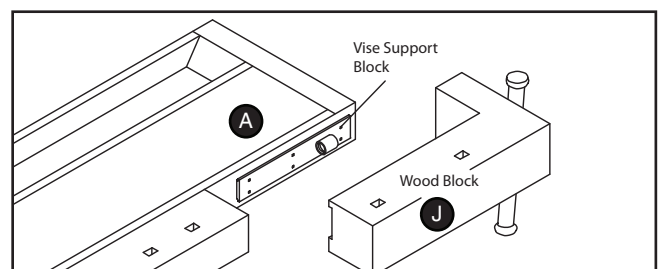
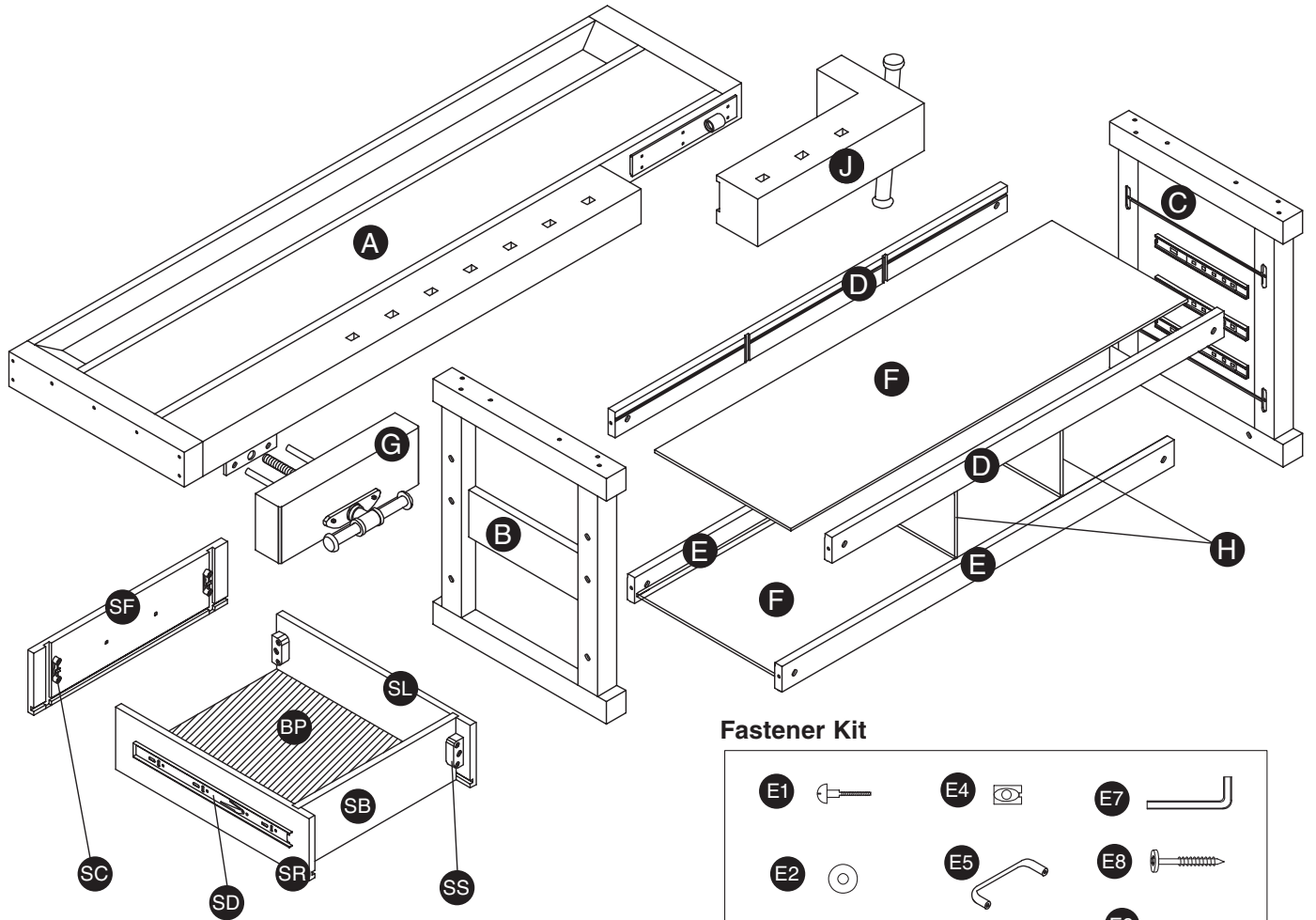

Figure 20. Tail vise installation.

23. Turn the tail vise handle clockwise until the wood block just touches the table, and attach the vise plate as outlined in **Step 21**.

Parts Breakdown and Inventory



Fastener Kit

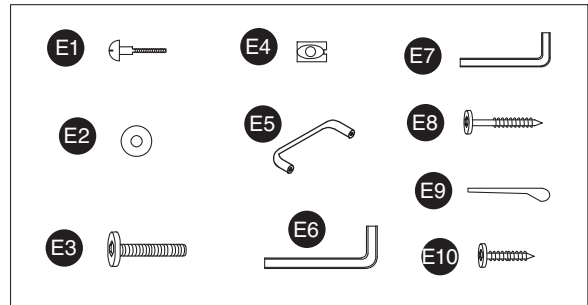

REF	PART	DESCRIPTION	QTY
A	PH8110018	BENCH TOP	1
B	PH8110019	LEFT SIDE LEG	1
C	PH8110020	RIGHT SIDE LEG	1
D	PH8110021	TOP CROSS BRACE	2
E	PH8110022	BOTTOM CROSS BRACE	2
F	PH8110023	CROSS PANEL	1
G	PH8110024	FRONT VISE	1
H	PH8110025	DRAWER SUPPORT	2
J	PH8110026	TAIL VISE	1
SS	PH8110010	BRACKET RECEIVER	36
SC	PH8110011	BRACKET	36
SL	PH8110012	DRAWER SIDE LEFT	9
SR	PH8110013	DRAWER SIDE RIGHT	9
SB	PH8110014	DRAWER SIDE BACK	9
BP	PH8110015	DRAWER BOTTOM	9
SF	PH8110016	DRAWER SIDE FRONT	9
SD	PH8110017	DRAWER SLIDE	18

Fastener Kit Part Numbers			QTY
E1	PH8110001	HANDLE SCREW	18
E2	PW01M	FLAT WASHER 8MM	12
E3	PH8110003	BARREL BOLT 3.5"	8
E4	PH8110004	BARREL NUT	8
E5	PH8110005	HANDLE	9
E6	PAW05M	HEX WRENCH 5MM	1
E7	PAW04M	HEX WRENCH 4MM	1
E8	PH8110008	WOOD SCREW 2"	4
E9	PH8110009	COTTER PIN	2
E10	PH8110030	WOOD SCREW #5 x 1 ⁷ / ₁₆ "	4



Free Manuals Download Website

<http://myh66.com>

<http://usermanuals.us>

<http://www.somanuals.com>

<http://www.4manuals.cc>

<http://www.manual-lib.com>

<http://www.404manual.com>

<http://www.luxmanual.com>

<http://aubethermostatmanual.com>

Golf course search by state

<http://golfingnear.com>

Email search by domain

<http://emailbydomain.com>

Auto manuals search

<http://auto.somanuals.com>

TV manuals search

<http://tv.somanuals.com>