

Grizzly *Industrial, Inc.*®

MODEL G9749 VARIABLE SPEED DRILL PRESS OWNER'S MANUAL



COPYRIGHT © SEPTEMBER, 2006 BY GRIZZLY INDUSTRIAL, INC.
**WARNING: NO PORTION OF THIS MANUAL MAY BE REPRODUCED IN ANY SHAPE
OR FORM WITHOUT THE WRITTEN APPROVAL OF GRIZZLY INDUSTRIAL, INC.**
#TS8502 PRINTED IN TAIWAN

WARNING!

This manual provides critical safety instructions on the proper setup, operation, maintenance and service of this machine/equipment.

Failure to read, understand and follow the instructions given in this manual may result in serious personal injury, including amputation, electrocution or death.

The owner of this machine/equipment is solely responsible for its safe use. This responsibility includes but is not limited to proper installation in a safe environment, personnel training and usage authorization, proper inspection and maintenance, manual availability and comprehension, application of safety devices, blade/cutter integrity, and the usage of personal protective equipment.

The manufacturer will not be held liable for injury or property damage from negligence, improper training, machine modifications or misuse.

WARNING!

Some dust created by power sanding, sawing, grinding, drilling, and other construction activities contains chemicals known to the State of California to cause cancer, birth defects or other reproductive harm. Some examples of these chemicals are:

- **Lead from lead-based paints.**
- **Crystalline silica from bricks, cement and other masonry products.**
- **Arsenic and chromium from chemically-treated lumber.**

Your risk from these exposures varies, depending on how often you do this type of work. To reduce your exposure to these chemicals: Work in a well ventilated area, and work with approved safety equipment, such as those dust masks that are specially designed to filter out microscopic particles.

Table of Contents

INTRODUCTION	2
Foreword	2
Contact Info.....	2
Machine Data Sheet.....	3
Identification	5
SECTION 1: SAFETY	6
Safety Instructions for Machinery.....	7
Additional Safety for Drill Presses.....	8
SECTION 2: CIRCUIT REQUIREMENTS	9
110/220V Operation	9
Grounding.....	10
Extension Cords.....	10
SECTION 3: SETUP	11
Setup Safety.....	11
Items Needed for Setup	11
Site Considerations	11
Unpacking and Lifting.....	12
Mounting to Shop Floor.....	13
Inventory.....	14
Clean Up	14
Assembly.....	15
Test Run and Spindle Break-In.....	16
SECTION 4: OPERATIONS	17
Installing Drill Chuck.....	17
Installing/Removing Drill Bits.....	18
Changing Speeds.....	18
Choosing Speeds.....	19
Drilling	20
Quill Travel	20
Table Adjustments	22
Headstock Rotation.....	22
Removing/Installing Arbor and Chuck.....	23
SECTION 5: ACCESSORIES	25
SECTION 6: MAINTENANCE	26
Schedule	26
Unpainted Cast Iron	26
Lubrication.....	26
SECTION 7: SERVICE	27
About Service.....	27
Troubleshooting.....	27
Electrical Components	29
Wiring Diagram	30
Headstock Parts Breakdown.....	31
Headstock Components Parts Breakdown	32
Variable Speed Parts Breakdown	33
Base Parts Breakdown.....	34
Label Placement	37
WARRANTY AND RETURNS	38

INTRODUCTION

Foreword

We are proud to offer the Model G9749 Variable Speed Drill Press. This machine is part of a growing Grizzly family of fine metalworking machinery. When used according to the guidelines set forth in this manual, you can expect years of trouble-free, enjoyable operation and proof of Grizzly's commitment to customer satisfaction.

We are pleased to provide this manual with the Model G9749. It was written to guide you through assembly, review safety considerations, and cover general operating procedures. It represents our effort to produce the best documentation possible.

The specifications, drawings, and photographs illustrated in this manual represent the Model G9749 as supplied when the manual was prepared. However, owing to Grizzly's policy of continuous improvement, changes may be made at any time with no obligation on the part of Grizzly. For your convenience, we always keep current Grizzly manuals available on our website at **www.grizzly.com**. Any updates to your machine will be reflected in these manuals as soon as they are complete. Visit our site often to check for the latest updates to this manual!

Contact Info

If you have any comments regarding this manual, please write to us at the address below:

Grizzly Industrial, Inc.
c/o Technical Documentation Manager
P.O. Box 2069
Bellingham, WA 98227-2069
E-Mail: manuals@grizzly.com

We stand behind our machines. If you have any service questions or parts requests, please call or write us at the location listed below.

Grizzly Industrial, Inc.
1203 Lycoming Mall Circle
Muncy, PA 17756
Phone: (570) 546-9663
Fax: (800) 438-5901
E-Mail: techsupport@grizzly.com
Web Site: <http://www.grizzly.com>





MACHINE DATA SHEET

Customer Service #: (570) 546-9663 · To Order Call: (800) 523-4777 · Fax #: (800) 438-5901

MODEL G9749 VS DRILL PRESS

Product Dimensions:

Weight..... 615 lbs.
 Length/Width/Height..... 33-1/8 x 22 x 75 in.
 Foot Print (Length/Width)..... 26 x 19 in.

Shipping Dimensions:

Type..... Wood Crate/Slats 2 S
 Content..... Machine
 Weight..... 776 lbs.
 Length/Width/Height..... 37 x 29 x 72 in.

Electrical:

Switch..... Reversible
 Switch Voltage..... 220V
 Cord Length..... 7 ft.
 Cord Gauge..... 14 gauge
 Recommended Breaker Size..... 20 amp
 Plug..... Yes

Motors:

Main

Type..... TEFC Capacitor Start Induction
 Horsepower..... 1-1/2 HP
 Voltage..... 220V
 Prewired..... 220V
 Phase..... Single
 Amps..... 16/8A
 Speed..... 1725 RPM
 Cycle..... 60 Hz
 Number Of Speeds..... 1
 Power Transfer V-Belt
 Bearings..... Shielded, Permanently Lubricated

Main Specifications:

Construction

Table Construction..... Cast Iron
 Spindle Housing Construction..... Cast Iron
 Column Construction..... Ground Cast Iron
 Head Construction..... Cast Iron
 Base Construction..... Cast Iron
 Paint..... Epoxy

Head Information

Head Swivel..... 360 deg.



Other Related Information

Base Length.....	26 in.
Base Width.....	18-1/2 in.
Quill Hold Type.....	Lock Lever with Gib
Quill Diameter.....	.3 in.
Depth Stop Type.....	Threaded Rod with Positive Stop
Column Diameter.....	4-1/2 in.

Spindle Information

Spindle Taper.....	MT#3
Spindle Travel.....	6-1/2 in.
Dist From Spindle To Column.....	9-3/4 in.
Dist From Spindle To Table.....	28-3/4 in.
Dist From Spindle To Base.....	50 in.

Table Information

Table Length.....	21-3/4 in.
Table Width.....	19-1/2 in.
Table Thickness.....	2 in.
Floor To Table Height.....	18 - 43 in.
Vertical Table Movement.....	Crank Handle Operate
Table Swivel Around Column.....	360 deg.
Maximum Movement Of Work Table.....	25 in.
No. Of T Slots.....	2
T Slot Width.....	1/2 in.
T Slot Length.....	15-1/2 in.

Operation Information

Swing.....	19-1/2 in.
Drilling Capacity.....	1-1/4 in.
No Of Spindle Speeds.....	Variable
Range Of Spindle Speeds.....	300 - 2000 RPM
Drill Chuck Type.....	JT6 Key Chuck
Drill Chuck Size.....	1/2 in.
End Milling Cap.....	3/4 in.
Face Milling Cap.....	.3 in.

Other Specifications:

ISO Factory	ISO 9001
Country Of Origin	Taiwan
Warranty	1 Year
Serial Number Location	ID Label on Head Casting
Assembly Time	10 minutes

Features:

- Graduations in 0.001 Inches
- Manual Fine Down Feed
- Quill Lock and Depth Stop
- MT #3 Spindle Taper
- Variable Speed
- 1-1/2HP Motor
- Table and Base are Cast Iron



Identification

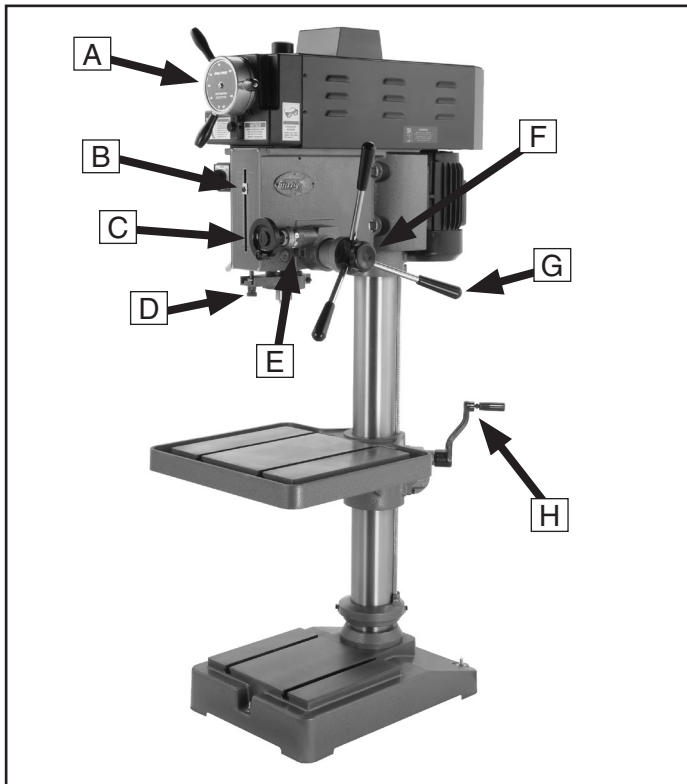

Figure 1. Right side controls.

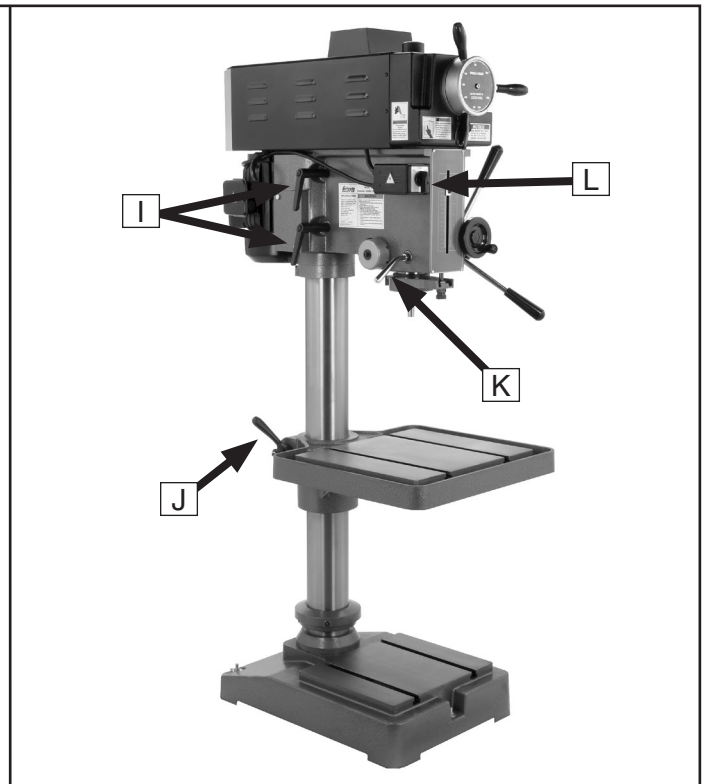

Figure 2. Left side controls.

Refer to the list below and see **Figures 1 & 2** to become familiar with the drill press controls.

- A. Speed Selector Control:** Allows variable speeds from 300 to 2000 RPM.
- B. Depth Gauge:** Indicates quill travel in centimeters and inches.
- C. Fine Downfeed Control:** Allows more precise management of the quill and tooling.
- D. Depth Stop:** Stops the quill travel at a pre-set drilling depth.
- E. Fine Downfeed Indicator:** Indicates fine downfeed adjustments in 0.001" increments.

- F. Clutch Knob:** Switches between rapid and fine downfeed control.
- G. Rapid Downfeed Control:** Provides a faster movement of the quill and tooling.
- H. Table Crank Handle:** Raises/lowers the table.
- I. Headstock Lock Levers:** Locks the headstock rotation.
- J. Table Lock Lever:** Locks the table height and rotation.
- K. Quill Lock Lever:** Locks the quill in place.
- L. Rotary Power Switch:** Selects forward, stop, or reverse.

SECTION 1: SAFETY

WARNING

For Your Own Safety, Read Instruction Manual Before Operating this Machine

The purpose of safety symbols is to attract your attention to possible hazardous conditions. This manual uses a series of symbols and signal words intended to convey the level of importance of the safety messages. The progression of symbols is described below. Remember that safety messages by themselves do not eliminate danger and are not a substitute for proper accident prevention measures.



Indicates an imminently hazardous situation which, if not avoided, **WILL** result in death or serious injury.



Indicates a potentially hazardous situation which, if not avoided, **COULD** result in death or serious injury.



Indicates a potentially hazardous situation which, if not avoided, **MAY** result in minor or moderate injury. It may also be used to alert against unsafe practices.

NOTICE

This symbol is used to alert the user to useful information about proper operation of the machine.

WARNING

Safety Instructions for Machinery

- 1. READ THE ENTIRE MANUAL BEFORE STARTING MACHINERY.** Machinery presents serious injury hazards to untrained users.
- 2. ALWAYS USE ANSI APPROVED SAFETY GLASSES WHEN OPERATING MACHINERY.** Everyday eyeglasses only have impact resistant lenses—they are NOT safety glasses.
- 3. ALWAYS WEAR A NIOSH APPROVED RESPIRATOR WHEN OPERATING MACHINERY THAT PRODUCES DUST.** Wood dust can cause severe respiratory illnesses.
- 4. ALWAYS USE HEARING PROTECTION WHEN OPERATING MACHINERY.** Machinery noise can cause permanent hearing loss.
- 5. WEAR PROPER APPAREL. DO NOT** wear loose clothing, gloves, neckties, rings, or jewelry that can catch in moving parts. Wear protective hair covering to contain long hair and wear non-slip footwear.
- 6. NEVER OPERATE MACHINERY WHEN TIRED OR UNDER THE INFLUENCE OF DRUGS OR ALCOHOL.** Be mentally alert at all times when running machinery.



WARNING

Safety Instructions for Machinery

7. **ONLY ALLOW TRAINED AND PROPERLY SUPERVISED PERSONNEL TO OPERATE MACHINERY.** Make sure operation instructions are safe and clearly understood.
8. **KEEP CHILDREN AND VISITORS AWAY.** Keep all children and visitors a safe distance from the work area.
9. **MAKE WORKSHOP CHILDPROOF.** Use padlocks, master switches, and remove start switch keys.
10. **NEVER LEAVE WHEN MACHINE IS RUNNING.** Turn power **OFF** and allow all moving parts to come to a complete stop before leaving machine unattended.
11. **DO NOT USE IN DANGEROUS ENVIRONMENTS.** DO NOT use machinery in damp, wet locations, or where any flammable or noxious fumes may exist.
12. **KEEP WORK AREA CLEAN AND WELL LIGHTED.** Clutter and dark shadows may cause accidents.
13. **USE A GROUNDED EXTENSION CORD RATED FOR THE MACHINE AMPERAGE.** Grounded cords minimize shock hazards. Undersized cords create excessive heat. Always replace damaged extension cords.
14. **ALWAYS DISCONNECT FROM POWER SOURCE BEFORE SERVICING MACHINERY.** Make sure switch is in OFF position before reconnecting.
15. **MAINTAIN MACHINERY WITH CARE.** Keep blades sharp and clean for best and safest performance. Follow instructions for lubricating and changing accessories.
16. **MAKE SURE GUARDS ARE IN PLACE AND WORK CORRECTLY BEFORE USING MACHINERY.**
17. **REMOVE ADJUSTING KEYS AND WRENCHES.** Make a habit of checking for keys and adjusting wrenches before turning machinery **ON**.
18. **CHECK FOR DAMAGED PARTS BEFORE USING MACHINERY.** Check for binding or misaligned parts, broken parts, loose bolts, and any other conditions that may impair machine operation. Repair or replace damaged parts before operation.
19. **USE RECOMMENDED ACCESSORIES.** Refer to the instruction manual for recommended accessories. Improper accessories increase risk of injury.
20. **DO NOT FORCE MACHINERY.** Work at the speed for which the machine or accessory was designed.
21. **SECURE WORKPIECE.** Use clamps or a vise to hold the workpiece when practical. A secured workpiece protects your hands and frees both hands to operate the machine.
22. **DO NOT OVERREACH.** Maintain stability and balance at all times.
23. **MANY MACHINES CAN EJECT WORKPIECES TOWARD OPERATOR.** Know and avoid conditions that cause the workpiece to "kickback."
24. **ALWAYS LOCK MOBILE BASES (IF USED) BEFORE OPERATING MACHINERY.**
25. **CERTAIN DUST MAY BE HAZARDOUS** to the respiratory systems of people and animals, especially fine dust. Be aware of the type of dust you are exposed to and always wear a respirator designed to filter that type of dust.



WARNING

Additional Safety for Drill Presses

- 1. EYE/FACE/HAND PROTECTION.** A face shield used with safety glasses is recommended. Always keep hands and fingers away from the drill bit. Never hold a workpiece by hand while drilling! **DO NOT** wear gloves when operating the drill.
- 2. SECURING BIT.** Properly tighten and securely lock the drill bit in the chuck.
- 3. CORRECT BIT.** Use only round, hex, or triangular shank drill bits.
- 4. ADJUSTING KEYS AND WRENCHES.** Remove all adjusting keys and wrenches before turning the machine **ON**.
- 5. DRILLING SHEET METAL.** Never drill sheet metal unless it is securely clamped to the table.
- 6. SURFACE/WORKPIECE PREP.** Never turn the drill press **ON** before clearing the table of all objects (tools, scraps, etc.). **DO NOT** drill material that does not have a flat surface, unless a suitable support is used.
- 7. DAMAGED TOOLS.** Never use drill bits in poor condition. Dull or damaged drill bits are hard to control and may cause serious injury.
- 8. DRILL OPERATION.** Never start the drill press with the drill bit in contact with the workpiece. Feed the drill bit evenly into the workpiece. Back the bit out frequently to clear deep holes.
- 9. CLEARING CHIPS.** Turn the machine **OFF** and clear chips and scrap pieces with a brush. Disconnect power, remove drill bit, and clean table before leaving the machine.
- 10. OPERATING SPEED.** Always operate your drill press at speeds that are appropriate for the drill bit size and the material that you are drilling.
- 11. MOUNTING WORKPIECES.** Use clamps or vises to secure workpiece before drilling. Position work so you avoid drilling into the table.
- 12. TABLE LOCK.** Make sure the table lock is tightened before starting the drill press.
- 13. MAINTENANCE.** Never do maintenance on the machine when it is connected to power.
- 14. EXPERIENCING DIFFICULTIES.** If at any time you are experiencing difficulties performing the intended operation, stop using the machine! Contact our Technical Support at (570) 546-9663.

WARNING

Like all machines there is danger associated with this machine. Accidents are frequently caused by lack of familiarity or failure to pay attention. Use this machine with respect and caution to lessen the possibility of operator injury. If normal safety precautions are overlooked or ignored, serious personal injury may occur.

CAUTION

No list of safety guidelines can be complete. Every shop environment is different. Always consider safety first, as it applies to your individual working conditions. Use this and other machinery with caution and respect. Failure to do so could result in serious personal injury, damage to equipment, or poor work results.



SECTION 2: CIRCUIT REQUIREMENTS

110/220V Operation

!WARNING

Serious personal injury could occur if you connect the machine to the power source before you have completed the setup process. **DO NOT** connect the machine to the power source until instructed to do so.

Amperage Draw

The Model G9749 features a 110/220V motor that is prewired for 220V and draws the following amps under maximum load:

Motor Draw at 110V 16 Amps
Motor Draw at 220V 8 Amps

Circuit Requirements

We recommend connecting your machine to a dedicated and grounded circuit that is rated for the amperage given below. Never replace a circuit breaker on an existing circuit with one of higher amperage without consulting a qualified electrician to ensure compliance with wiring codes. **If you are unsure about the wiring codes in your area or you plan to connect your machine to a shared circuit, consult a qualified electrician.**

110V Circuit..... 30 Amps
220V Circuit..... 20 Amps

Plug/Receptacle Type

We recommend using one of the following plugs for your machine on a dedicated circuit only (see **Figures 3 & 4** for examples):

110V Plug & Receptacle L5-30
220V Plug (provided) & Receptacle 6-15

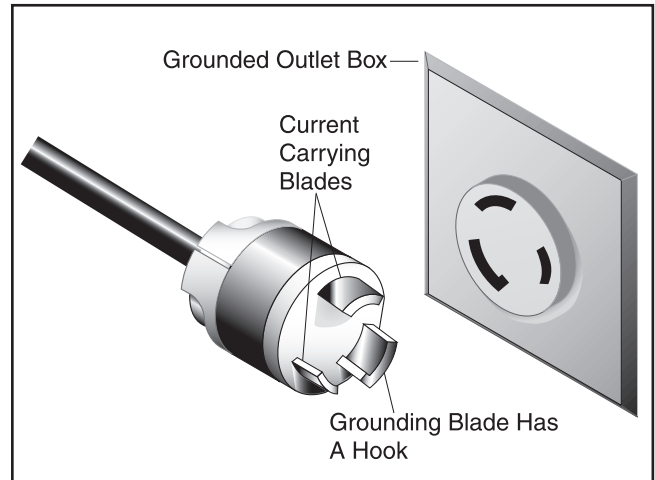

Figure 3. L5-30 plug and receptacle.

NOTICE

The Model G9749 is prewired for 220V operation. If you plan to rewire your machine for 110V, you must change the motor wiring, plug, and power receptacle. Consult a qualified electrician before attempting to rewire your machine!

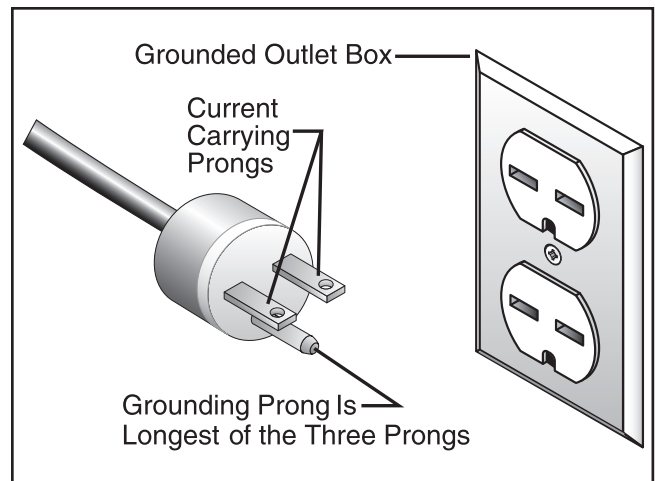
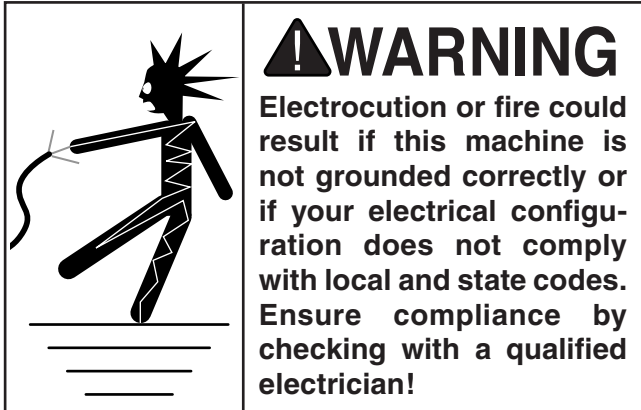

Figure 4. 6-15 plug and receptacle.

Grounding

In the event of an electrical short, grounding reduces the risk of electric shock. The grounding wire in the power cord must be properly connected to the grounding prong on the plug; likewise, the outlet must be properly installed and grounded. All electrical connections must be made in accordance with local codes and ordinances.



Extension Cords

220V Operation

We do not recommend the use of extension cords. Instead, arrange the placement of your equipment and the installed wiring to eliminate the need for extension cords.

If you must use an extension cord at 220V with your machine:

- Use at least a 14 gauge cord no longer than 50 feet!
- The extension cord must also contain a ground wire and plug pin.
- A qualified electrician **MUST** size cords over 50 feet long to prevent motor damage.

110V Operation

We do not recommend the use of extension cords. Instead, arrange the placement of your equipment and the installed wiring to eliminate the need for extension cords.

If you must use an extension cord at 110V with your machine:

- Use at least a 12 gauge cord no longer than 50 feet!
- The extension cord must also contain a ground wire and plug pin.
- A qualified electrician **MUST** size cords over 50 feet long to prevent motor damage.



SECTION 3: SETUP

Setup Safety

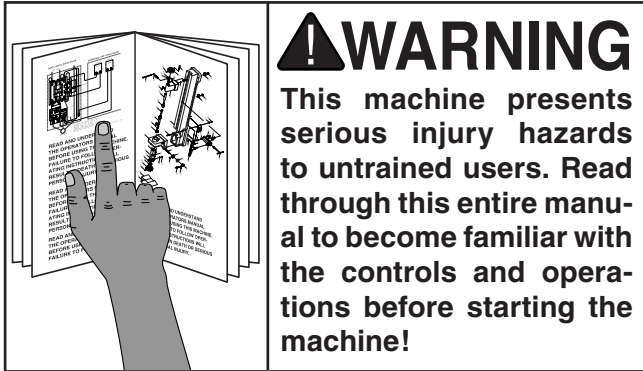

Items Needed for Setup

The following items are needed to complete the setup process, but are not included with your machine:

Description	Qty
• Assistance	1 or more persons
• 1/2-Ton Forklift or Crane, and Operator (for lifting/moving).....	1
• 1/2-Ton Lifting Straps (for lifting/moving)	2
• 1/2-Ton Hook (for lifting/moving)	1
• Safety Glasses (for each person)	1
• Degreaser/Solvent (for clean-up) As needed	
• Shop Rags (for clean-up)	As needed
• Open end wrench 9/16"	1

Site Considerations

Floor Load

Refer to the **Machine Data Sheet** on **Page 3** for the weight and footprint specifications of your machine. Some residential floors may require additional reinforcement to support both the machine and operator.

Placement Location

When establishing a location for your new machine, consider existing and anticipated needs, size of material to be processed through this machine, and space for auxiliary stands, work tables or other machinery. See **Figure 5** for the minimum working clearances.

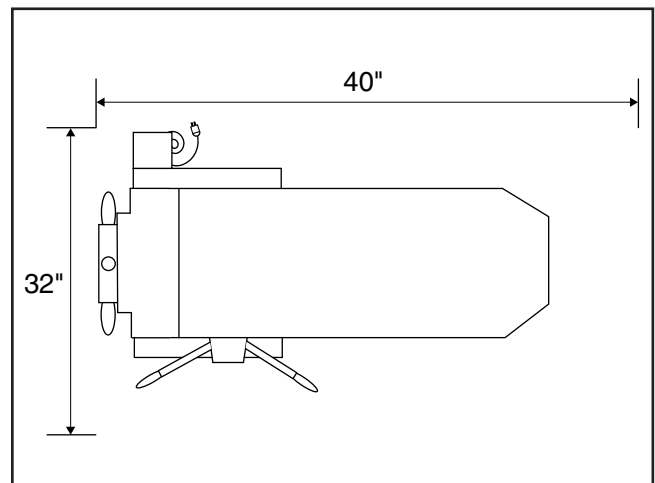

Figure 5. Minimum working clearances.





The Model G9749 weighs 615 lbs. You will need power lifting equipment and assistance to remove this machine from the pallet and position it. Inspect all lifting equipment and make sure that all is in perfect working order and is rated for the load before attempting to lift and move this drill press. Ignoring this warning may lead to serious personal injury or death.

Unpacking and Lifting

The Model G9749 was carefully packed when it left our warehouse. If you discover the machine is damaged after you have signed for delivery, *please immediately call Customer Service at (570) 546-9663 for advice.*

Save the containers and all packing materials for possible inspection by the carrier or its agent. *Otherwise, filing a freight claim can be difficult.*

When you are completely satisfied with the condition of your shipment, you should inventory the contents.

To unpack and move the drill press:

1. Read this entire **SETUP** section before continuing. Pay special attention to **Site Considerations** on **Page 11** and **Mounting to Shop Floor** on **Page 13**.
2. Remove the sides and top of the shipping crate.
3. Position the lifting straps under the headstock as shown in **Figure 6**. Make sure the straps are not in contact with any controls, wires, or handles.

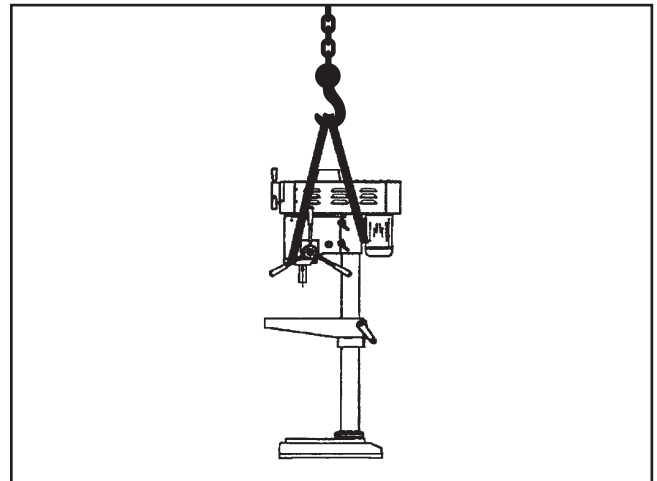

Figure 6. Location of lifting straps.

4. Position lifting straps, your lifting device, and your assistant to support the drill press in a vertical and stable position.
5. Unbolt the drill press from the pallet.
6. Slowly raise the drill press from the pallet, then carefully move the drill press to your prepared location.
7. With the drill press securely resting on the floor, shim between the floor and drill press base as required to level the drill press table.
8. Secure the drill press to the floor, but **DO NOT** overtighten the fasteners.
9. Recheck the table to make sure that it is still level, and re-shim as required.

Mounting to Shop Floor

The Model G9749 should be mounted to the floor. Because floor materials may vary, floor mounting hardware is not included. It is also necessary to level your machine with a precision level.

Bolting to Concrete Floors

Lag shield anchors with lag bolts (see **Figure 7**) and anchor studs (see **Figure 8**) are two popular methods for anchoring an object to a concrete floor. We suggest you research the many options and methods for mounting your machine and choose the best that fits your specific application.

NOTICE

Anchor studs are stronger and more permanent alternatives to lag shield anchors; however, they will stick out of the floor, which may cause a tripping hazard if you decide to move your machine.

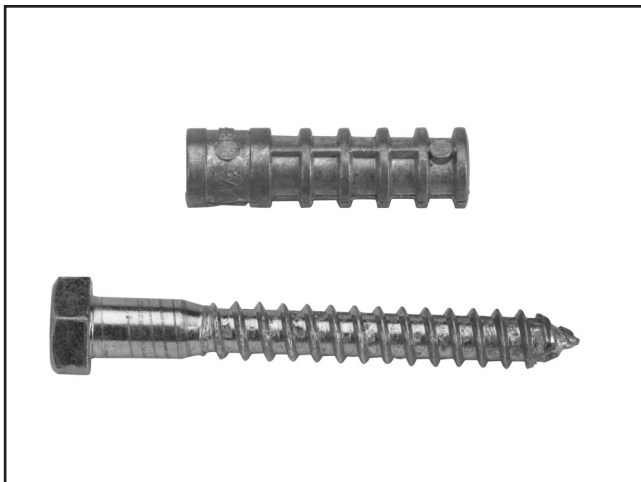

Figure 7. Typical lag shield anchor and lag bolt.



Figure 8. Typical anchor stud.

To mount the drill press to the floor:

1. With the drill press securely resting on the floor, shim between the floor and drill press base as required to level the drill press table.
2. Secure the drill press to the floor, but **DO NOT** overtighten the fasteners.

NOTICE

Shims may be required when mounting the drill press to the floor. If the floor is uneven and you tighten the mounting bolts without shims, you can crack the cast iron base. Shim any gaps between the base and the floor before fully tightening the mounting bolts.

3. Recheck the table to make sure that it is still level, and re-shim as required.
4. When the drill press is level and all gaps are shimmed, securely tighten the mounting bolts.

Inventory

After all the parts have been removed from the crate and boxes, you should have the following items:

Contents (Figure 9)	Qty
A. Drill Press (not shown).....	1
B. JT#6 Keyed Chuck.....	1
C. Chuck Key.....	1
D. Hex Wrench 5mm.....	1
E. Hex Wrench 4mm.....	1
F. Rapid Downfeed Handle Shafts.....	3
G. Rapid Downfeed Handle Knobs.....	3
H. Table Crank Knob.....	1
I. Drift Key.....	1

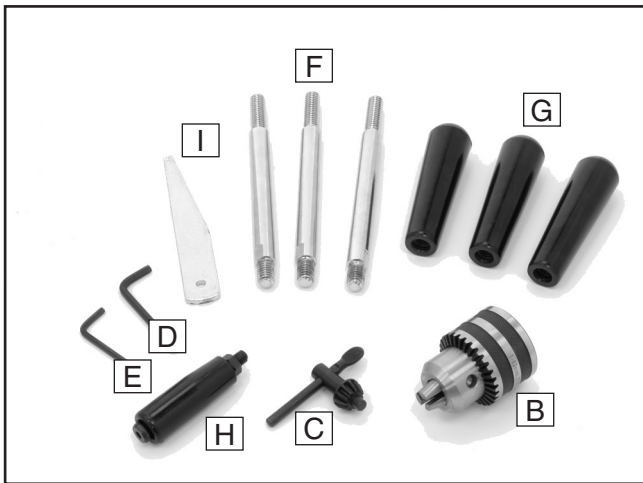

Figure 9. Model G9749 inventory.

If any nonproprietary parts are missing (e.g. a nut or a washer), we will gladly replace them, or for the sake of expediency, replacements can be obtained at your local hardware store.

NOTICE

Some hardware/fasteners on the inventory list may arrive pre-installed on the machine. Check these locations before assuming that any items from the inventory list are missing.

Clean Up

The unpainted surfaces are coated with a waxy oil to protect them from corrosion during shipment. Remove this protective coating with a solvent cleaner or citrus-based degreaser such as Grizzly's G7895 Degreaser. Some parts may need to be removed for thorough cleaning. **For optimum performance from your machine, make sure you clean all moving parts or sliding contact surfaces that are coated.** Avoid chlorine-based solvents, such as acetone or brake parts cleaner, as they may damage painted surfaces should they come in contact. Always follow the manufacturer's instructions when using any type of cleaning product.

Note: Refer to the **Lubrication** section on **Page 26** to relubricate any necessary areas that have been cleaned with solvent during the **Clean Up** process.

	<p>! WARNING</p> <p>Gasoline and petroleum products have low flash points and could cause an explosion or fire if used to clean machinery. DO NOT use gasoline or petroleum products to clean the machinery.</p>
--	--

	<p>! CAUTION</p> <p>Many of the solvents commonly used to clean machinery can be toxic when inhaled or ingested. Lack of ventilation while using these solvents could cause serious personal health risks or fire. Take precautions from this hazard by only using cleaning solvents in a well ventilated area.</p>
--	--



Assembly

Components and Hardware Needed:	Qty
Hex Wrench 5mm (provided)	1
Rapid Downfeed Handle Shafts	3
Rapid Downfeed Handle Knobs	3
Table Crank Knob	1
Open End Wrench $\frac{9}{16}$ "	1

To install the rapid downfeed handles:

1. Screw each knob onto the shaft end with the longest thread pattern.
2. Screw the resulting handle assembly into the threaded holes on the rapid downfeed control base (see **Figure 10**).

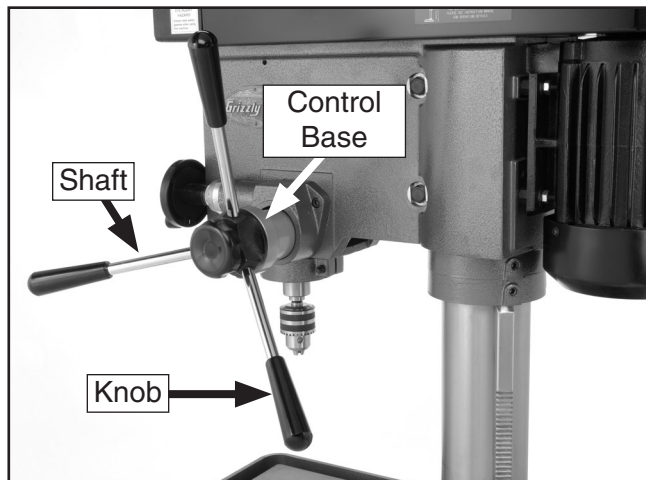

Figure 10. Rapid downfeed handles installed in control base.

3. Use a $\frac{9}{16}$ " wrench to tighten the shaft to the control base.

To install the table crank handle:

1. Screw the table crank handle into the threaded hole on the table crank (see **Figure 11**).

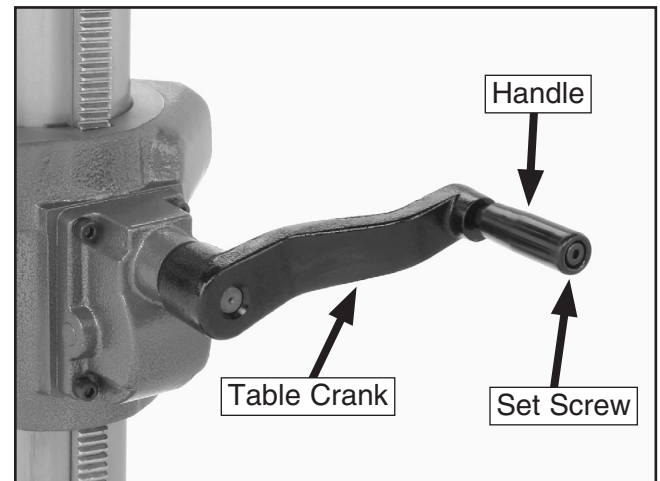
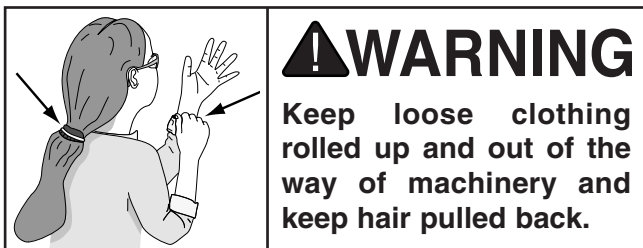

Figure 11. Table crank handle installed.

2. Use a 5mm hex wrench (provided) to tighten the set screw in the end of the handle.

Test Run and Spindle Break-In



Once assembly is complete, test run your machine to make sure it runs properly.

To test run the machine:

1. Make sure you have read and understood all of the safety instructions starting on **Page 6** of this manual, and verify the machine is set up properly.
2. Do NOT install the chuck before completing the **Test Run**.
3. Connect the drill press to the proper power source (reference **Circuit Requirements** on **Page 9**).
4. Make sure all tools and objects used during the setup are cleared away from the machine.
5. Turn the machine **ON** by moving the power switch to **FWD**.

NOTICE

DO NOT attempt to change speeds unless the drill press is **ON**. Attempting to rotate the speed control when the drill press is **OFF** could damage the variable speed mechanism.

6. Use the speed control to reduce the speed to 300 RPM and let the drill press run for a minimum of 10 minutes.
7. Listen and watch for abnormal noises or vibrations. The machine should run smoothly.

—Unusual noises or vibrations should be investigated and corrected before operating the machine further. Always disconnect the machine from power when investigating or correcting potential problems.

—If you cannot easily locate the source of a potential problem, refer to **Troubleshooting** on **Page 27**, or contact our Technical Support at (570) 546-9663.

8. Repeat **Steps 6–7** at 750 RPM, and then again at 2000 RPM.
 9. Turn the drill press **OFF** by moving the power switch to **Stop**.
- NOTE:** Wait for the spindle and tooling to come to a complete stop before proceeding.
10. Move the power switch to **REV** and repeat **Steps 6–8**.

! CAUTION

Do NOT attempt to stop or slow the spindle by hand. Failure to heed this caution could result in serious personal injury.



SECTION 4: OPERATIONS

NOTICE

If you have never used this type of machine or equipment before, **WE STRONGLY RECOMMEND** that you read books, trade magazines, or get formal training before beginning any projects. Regardless of the content in this section, Grizzly Industrial will not be held liable for accidents caused by lack of training.



WARNING

Wear safety glasses when operating this machine. Serious injury may occur if this warning is ignored!

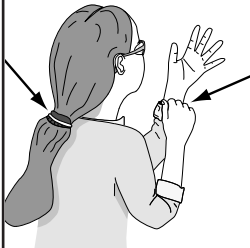

WARNING

Loose hair and clothing could get caught in machinery and cause serious personal injury. Keep loose clothing and long hair away from moving machinery.

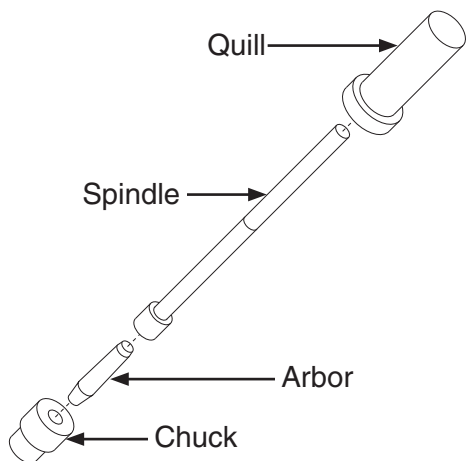

Figure 12. Identification of typical quill, spindle, arbor and chuck with Morse and Jacobs tapers.

Installing Drill Chuck

A JT#6 (Jacobs Taper #6) keyed chuck is included with the Model G9749 drill press.

To install the drill chuck onto the arbor:

1. UNPLUG THE DRILL PRESS!

Note: The arbor and spindle come from the factory pre-installed into the quill. To replace the arbor or spindle, refer to the **Removing/Installing Arbor and Chuck** section on **Page 23**.

2. Prepare the mating surfaces of the arbor and the chuck by cleaning them thoroughly.
3. Retract the chuck jaws all the way inside the chuck.
4. Push the chuck onto the arbor, and using a wood block and hammer or mallet as shown in **Figure 13**, hit the chuck ONCE with moderate force to secure it on the arbor.

Note: Hitting the chuck directly with a steel hammer or with excess force may damage the chuck, making it unsafe to use.

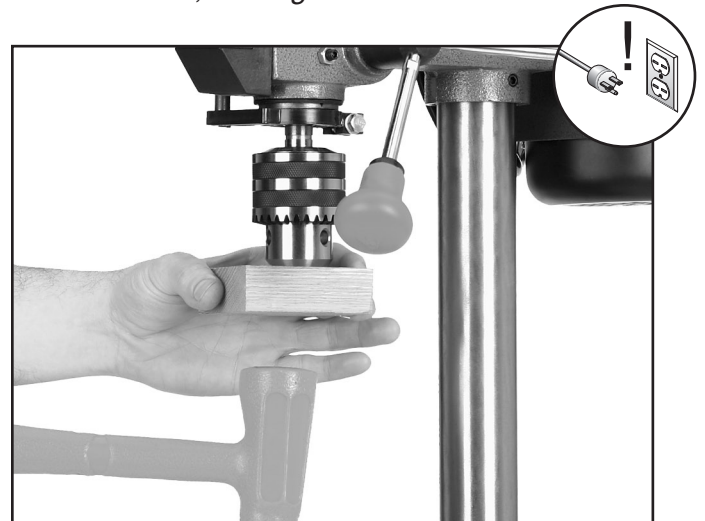

Figure 13. Chuck being seated on the arbor.

Installing/Removing Drill Bits

Any drill bit you install in the chuck must be tight enough that it will not come loose during operation.

To install a drill bit into the chuck:

1. UNPLUG THE DRILL PRESS!
2. Open the chuck jaws wide enough to accept the drill bit shank.
3. Insert the drill bit as far as possible into the chuck WITHOUT allowing the chuck jaws to touch the fluted or cutting portion of the drill bit, then hand tighten the chuck.

Note: Make sure small drill bits are not trapped between the edges of two jaws. If they are, reinstall the drill bit properly before use.

4. Use the included chuck key to fully tighten the chuck around the drill bit.

To remove a drill bit from the chuck:

1. UNPLUG THE DRILL PRESS!
2. Use the chuck key to open the chuck, and catch the drill bit with a rag to protect your hands.

Changing Speeds

NOTICE

DO NOT attempt to change speeds unless the drill press is **ON**. Attempting to rotate the speed control when the drill press is **OFF** could damage the variable speed mechanism.

The Model G9749 drill press is capable of variable speeds from 300-2000 RPM. Refer to **Choosing Speeds** on **Page 19** for the correct speed for the cutting tool and material being used.

To change speed of the drill press:

1. Turn the drill press **ON**.
2. Loosen the speed control locking knob (see **Figure 14**).

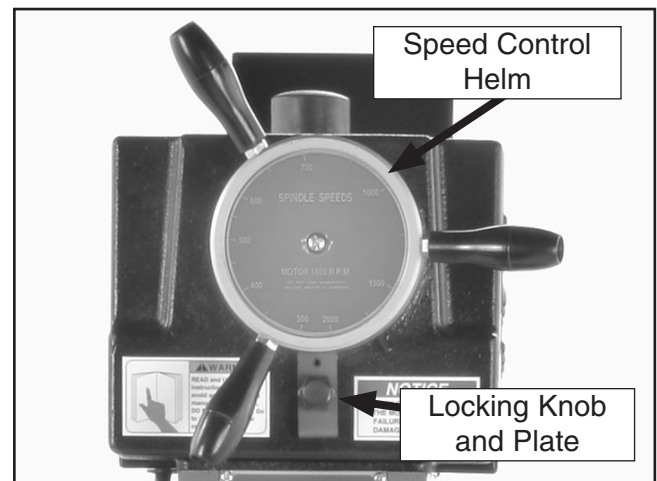

Figure 14. Speed control handles and helm.

3. Using the small reference mark or notch on the outside ring of the speed control helm as a guide, **SLOWLY** rotate the speed control to the desired speed.

Note: Rotating the speed control helm too fast will greatly increase the wear on the drive belts and pulleys.

4. Tighten the speed control locking knob to hold the helm in place against machine vibration.



Choosing Speeds

Using the Drill Bit Speed Chart

The chart shown in **Figure 15** is intended as a guide only. Always follow the manufacturer's speed recommendations if provided with your drill bits, cutters, or hole saws. Exceeding the recommended speeds may put the operator in danger.

The speeds shown here are intended to get you started. The optimum speed will always depend on various factors, including tool diameter, drilling pressure, material hardness, material quality, and desired finish.

Some type of lubrication is often necessary to drill materials other than wood.

Lubrication Suggestions

Wood & Cast Iron None
 Plastics Soapy Water
 Brass Water-Based Lubricant
 Aluminum.....Paraffin-Based Lubricant
 Mild Steel.....Oil-Based Lubricant

CAUTION

Larger bits turning at slower speeds tend to grab the workpiece aggressively. This can result in the operator's hand being pulled into the bit or the workpiece being thrown with great force. Always clamp the workpiece to the table to prevent injuries.

Twist/Brad Point Drill Bits	Soft Wood	Hard Wood	Plastic	Brass	Aluminum	Mild Steel
1/16" – 3/16"	3000	2500	2500	2500	3000	2500
13/64" – 3/8"	2000	1500	2000	1250	2500	1250
25/64" – 5/8"	1500	750	1500	750	1500	600
11/16" – 1"	750	500	1000	400	1000	350

Spade/Forstner Bits	Soft Wood	Hard Wood	Plastic	Brass	Aluminum	Mild Steel
1/4" – 1/2"	2000	1500				
9/16" – 1"	1500	1250				
1-1/8" – 1-7/8"	1000	750				
2–3"	500	350				

Hole Saws	Soft Wood	Hard Wood	Plastic	Brass	Aluminum	Mild Steel
1/2" – 7/8"	500	500	600	600	600	500
1" – 1-7/8"	400	400	500	500	500	400
2" – 2-7/8"	300	300	400	400	400	300
3" – 3-7/8"	200	200	300	300	300	200
4" – 5"	100	100	200	200	200	100

Rosette Cutters	Soft Wood	Hard Wood	Plastic	Brass	Aluminum	Mild Steel
Carbide Insert Type	350	250				
One-Piece Type	1800	500				

Tenon/Plug Cutters	Soft Wood	Hard Wood	Plastic	Brass	Aluminum	Mild Steel
3/8" – 1/2"	1200	1000				
5/8" – 1"	800	600				

Figure 15. Cutting tool speed chart.



Drilling

The basic operation when drilling is:

1. Line up your drill bit with the intended hole location.
2. Clamp the workpiece to the table.
3. Turn the drill press **ON**.
4. Use the downfeed handles to move the spinning drill bit into the workpiece.

For safe operation and optimum results when drilling, follow these guidelines:

CLEAR CHIPS: Raise the drill bit often to clear chips and cool the drill bit. This will ease the work of the drill press motor and extend the life of your drill bits.

SECURE WORKPIECE TO TABLE: Clamp the workpiece to the table or in a vise that is secured to the table before drilling.

PROTECT THE TABLE: Protect the table by placing the workpiece on scrap wood when through drilling. Also, use the depth stop to ensure that the drill bit goes no deeper than necessary.

USE CORRECT SPEEDS: Use the correct speed for the diameter of the drill bit being used and the type of material being drilled. Refer to **Choosing Speeds** on **Page 19** to select the correct speed for your application.

ADJUST SPEED TO DIAMETER OF BIT: Reduce speed when using large diameter bits; increase speeds when using smaller diameter bits.

ADJUST SPEED TO MATERIAL: Use slower speeds with harder materials. Softer materials can be drilled with higher speeds. However, some materials, such as plastics, can melt at high speeds.

APPLY LUBRICANT: Use some form of lubricant on all materials except wood or cast iron. Refer to **Lubrication Suggestions** on **Page 19** to find the correct lubrication for your application.

DRILL ACCURATELY: Mark the hole location with a center punch before drilling to prevent drill bit wandering and to ensure accurate placement of holes. Consider using a center-point drill to start the hole.

CAUTION

If the workpiece is not clamped down, the operator's hand could get pulled into the bit or the workpiece can be thrown with great force. Clamp the workpiece to the table before drilling.

Quill Travel

The Model G9749 has both a rapid and a fine downfeed control for quill travel. Quill travel can be set to a specific distance using the depth gauge and depth stop.

To use the quill lock:

1. To lock the quill in place, rotate the quill lock lever (see **Figure 18** on **Page 21**) clockwise and hand tighten.
2. Unlock the quill by rotating the quill lock lever counterclockwise.

Note: *The quill has a strong tendency to travel upward quickly if not controlled. Use the downfeed control to manage the quill movement when the quill is not locked in place. Also, for maximum rigidity, the quill should not be extended any more than necessary to drill the hole. Adjust the table height if greater distances are needed.*



To use the rapid downfeed control:

1. Rotate the clutch knob (see **Figure 16**) counterclockwise until it stops.

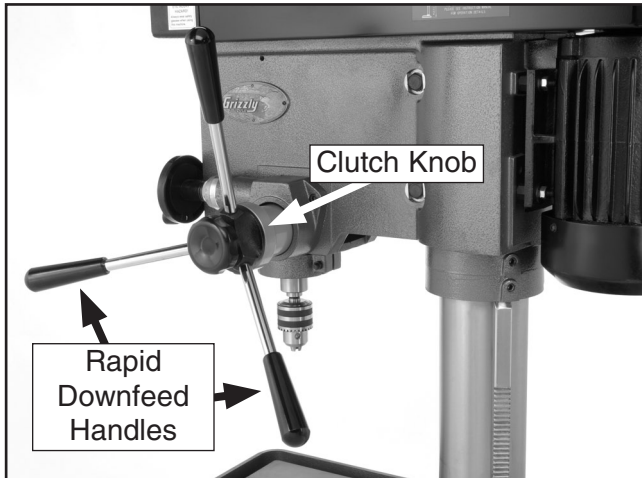

Figure 16. Rapid downfeed control.

2. While holding the rapid downfeed handles steady, unlock the quill.
3. Using the rapid downfeed handles and depth gauge, move the quill to the desired position.

The fine downfeed control is used for precise movement of the quill and tooling, and can be used with the graduated dial in 0.001" increments.

To use the fine downfeed control:

1. Rotate the clutch knob clockwise until it stops (see **Figure 16**).
2. Use the fine downfeed control to hold the quill in place while you unlock the quill (see **Figure 17**).

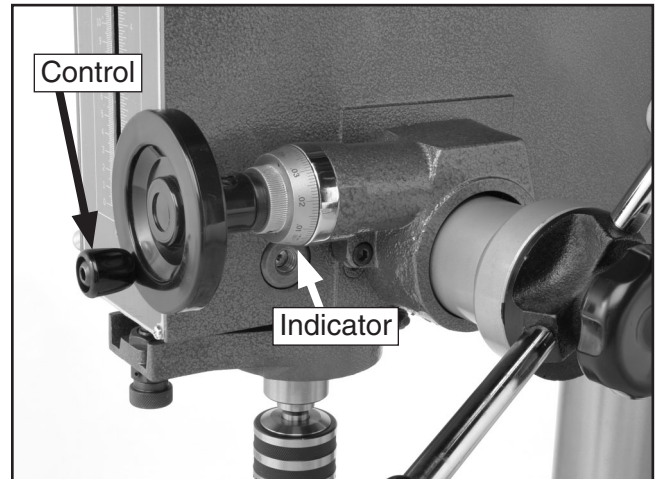

Figure 17. Fine downfeed control and indicator.

3. Use the fine downfeed control and the attached indicator to move the quill to the desired position.

To use the depth gauge and depth stop:

1. Rotate the depth stop knob until the depth gauge reference marker indicates the desired depth (see **Figure 18** on **Page**).

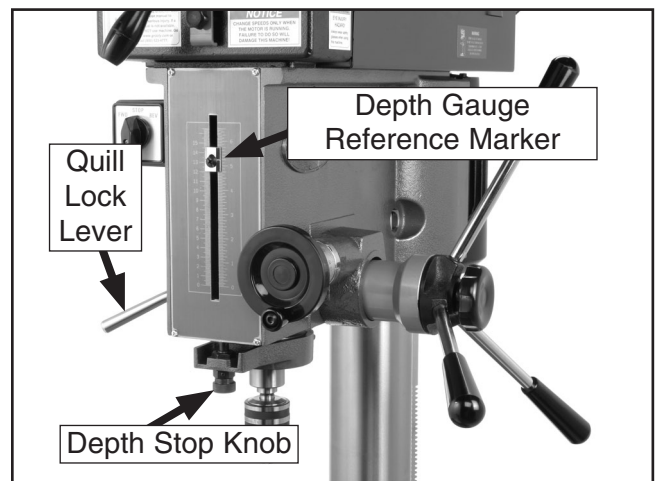

Figure 18. Depth gauge.

2. Using either the rapid or fine downfeed controls described below, bring the quill down until the depth gauge reference marker reaches zero.

Table Adjustments

The table can be raised/lowered and rotated 360° around the column.

To adjust table height and rotation:

1. Make sure the table lock lever is mounted on the locking nut as shown in **Figure 19**.

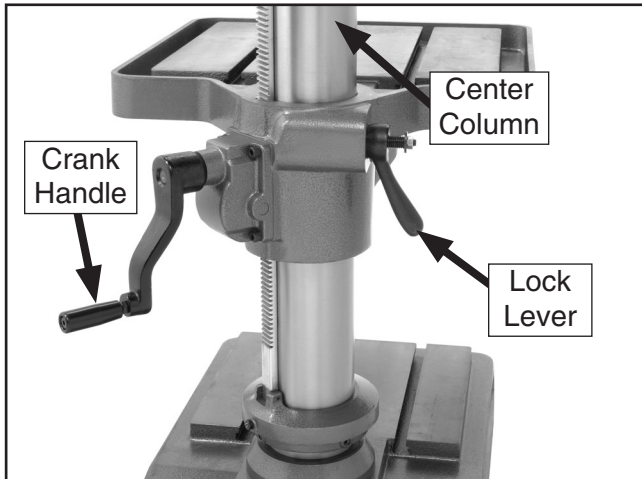

Figure 19. Table crank handle and lock lever.

2. Unlock the table by rotating the lock lever clockwise.
3. The table can now be adjusted:
 - Vertically by using the table crank handle (see **Figure 19**).
 - Horizontally by manually rotating the assembly around the center column.
4. When you have the table in the desired position, use the lock lever to keep in place.

Headstock Rotation

The headstock can be adjusted 360° around the column.

To rotate the headstock:

Note: Make sure the drill press is properly bolted to the floor before doing this procedure.

1. UNPLUG THE DRILL PRESS!
2. Rotate the two headstock lock levers counter-clockwise to loosen them (see **Figure 20**).

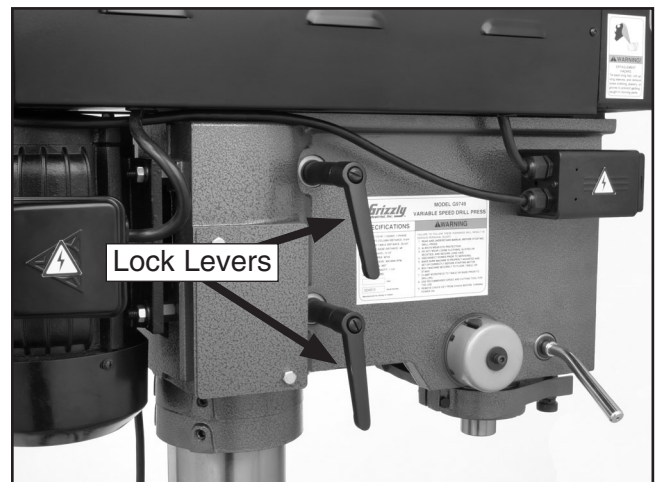

Figure 20. Headstock lock levers.

3. Rotate the headstock to the desired position and use the lock levers to secure the headstock in place.

Removing/Installing Arbor and Chuck

Use the drawbar included with the Model G9749 to connect the included drill chuck arbor.

To remove the arbor and chuck from the spindle:

1. UNPLUG THE DRILL PRESS!
2. Use a 3mm hex wrench to remove the belt housing cover (see **Figure 21**).

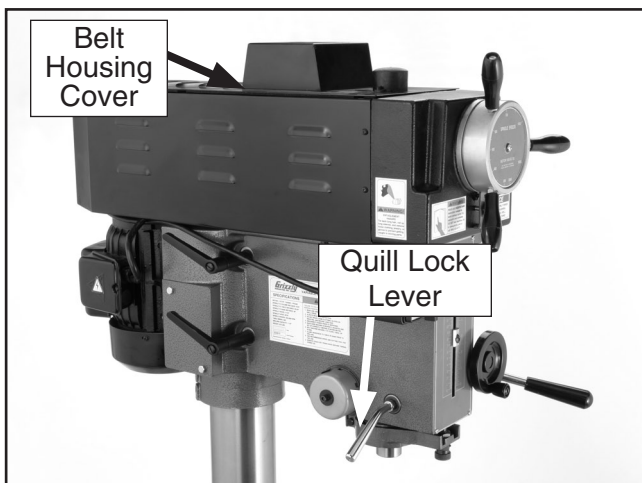

Figure 21. Belt housing cover.

3. Raise the quill to the highest position, and hold it place by tightening the quill lock lever.
4. Use a 17mm wrench to unscrew the drawbar 2–3 full turns without removing the threads from the arbor (see **Figure 22**).

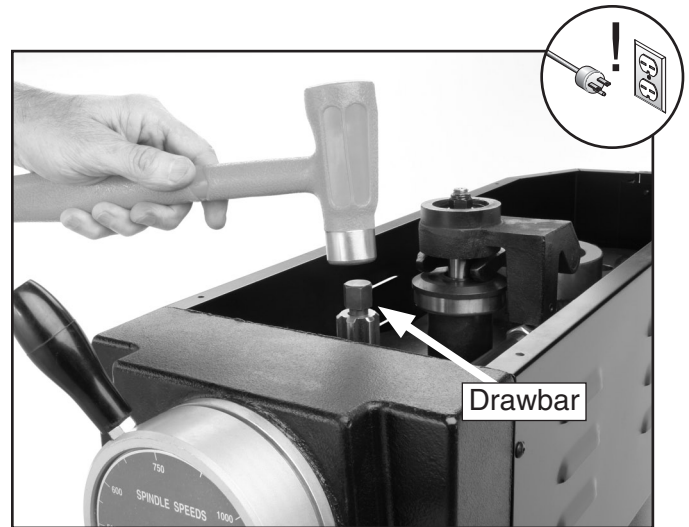

Figure 22. Tapping top of drawbar.

5. Using a brass hammer or rubber mallet, strike the drawbar from the top, as shown in **Figure 22**, with a firm blow until the arbor releases from the spindle.
6. While holding the arbor and chuck with one hand, unthread the drawbar completely from the arbor.

⚠ WARNING

DO NOT operate the drill press when the belt housing cover is open. The movement of the belts and pulleys inside the headstock may entangle hands or clothes causing serious personal injury.

To remove the chuck from the arbor:

1. UNPLUG THE DRILL PRESS!
2. Turn the chuck and arbor assembly upside down.
3. Retract the jaws of the chuck completely inside the chuck.
4. To avoid scratching the mating surface of the arbor, support the chuck in a way that leaves the arbor free from any contact with other objects.
5. Insert an appropriate tool inside the chuck so that it makes firm contact with the end of the arbor.
6. Hold the arbor with one hand and firmly strike the inserted tool with a hammer until the arbor releases from the chuck.

To install the arbor into the spindle with the drawbar:

1. UNPLUG THE DRILL PRESS!
2. Make sure the mating surfaces of the spindle and arbor are clean and free of any debris or grease.
3. Insert the arbor into the spindle as shown in **Figure 23**.

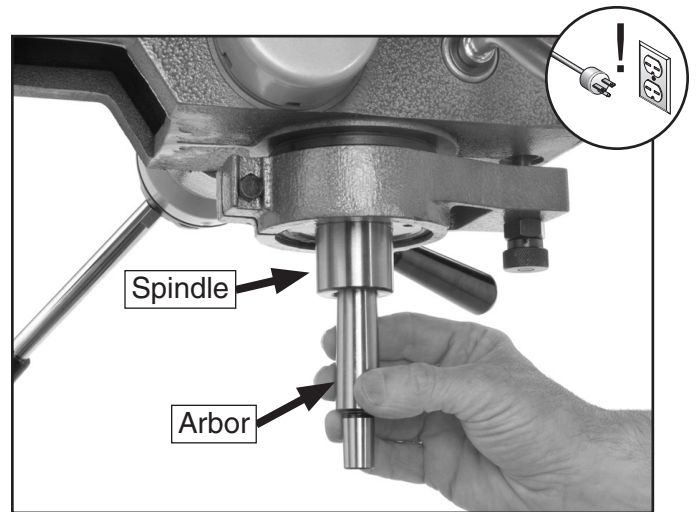

Figure 23. Inserting the arbor into the spindle.

4. While holding the arbor in place, hand tighten the drawbar to the arbor.
5. Finish tightening by making a $\frac{1}{2}$ turn with a 17mm wrench.
6. Replace and secure the belt housing cover.

NOTICE

Do NOT overtighten the drawbar. Overtightening the drawbar may cause damage to the mating surfaces of the spindle and arbor.

SECTION 5: ACCESSORIES

G2500—20-PC Regular Sanding Drum Set

This kit consists of 5 drums in popular $\frac{1}{2}$ " x $\frac{1}{2}$ ", $\frac{3}{4}$ " x 1", 1" x 1", 1 $\frac{1}{2}$ " x 1 $\frac{1}{2}$ ", and 2" x 1 $\frac{1}{2}$ " sizes. Comes with 50, 80 and 120 grit sizes for each drum.



Figure 24. Model G2500 20-PC Sanding Drum Set.

G8865—Cobalt Alloy Drill Bits 13-PC. Set

G8866—Steelex® Cobalt Alloy Drill Set 21-PC

G8867—Steelex® Cobalt Alloy Drill Set 29-PC

Cobalt Alloy bits will retain their edge sharpness longer than normal HSS bits, resulting in a significant saving of time and money in the workshop. Includes a heavy-gauge steel index case for storing. G8865: $\frac{1}{16}$ " - $\frac{1}{4}$ "; G8866: $\frac{1}{16}$ " - $\frac{3}{8}$ "; G8867: $\frac{1}{16}$ " - $\frac{1}{2}$ ".



Figure 25. Model G8865 13-PC Alloy Drill Bits.

H5685—4" Rotary Table

The perfect rotary table for all you model makers and those doing smaller precision work. Comes with clamping kit.



Figure 26. H5685 4" Rotary Table.

G1076—52-PC. Clamping Kit

This clamping kit includes 24 studs, 6 step block pairs, 6 T-nuts, 6 flange nuts, 4 coupling nuts, and 6 end hold-downs. The rack is slotted so it can be mounted close to the machine for easy access.

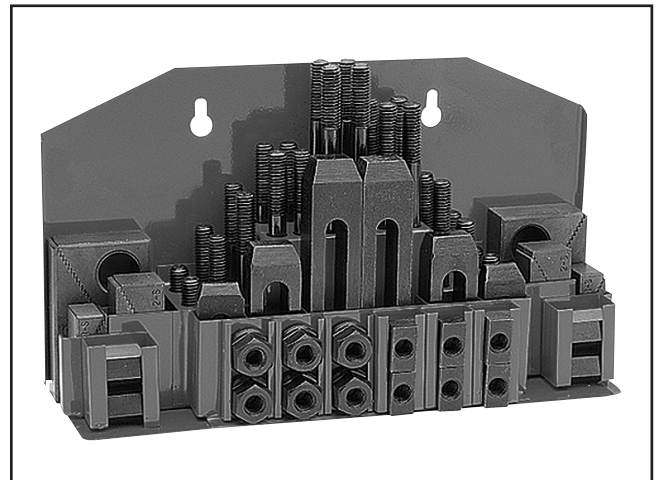
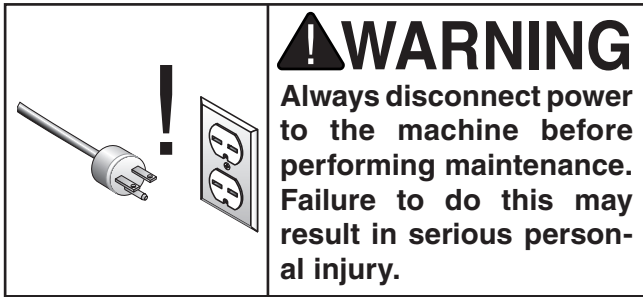

Figure 27. G1076 52-PC. Clamping Kit.

Call 1-800-523-4777 To Order

SECTION 6: MAINTENANCE



Schedule

For optimum performance from your machine, follow this maintenance schedule and refer to any specific instructions given in this section.

Daily Check:

- Drill press is completely powered down at the end of use.
- Excess cutting fluids and chips have been removed and unpainted surfaces are dry and protected.
- Floor mounting bolts are secure.
- Drill press is clean and lubricated.
- Examine wiring for damage or wear.
- Check for any other unsafe condition.

Unpainted Cast Iron

Protect the unpainted cast iron surfaces on the table by removing vises and fixtures daily and by wiping the table clean after every use.

Keep tables rust-free with regular applications of products like G96® Gun Treatment or Boeshield® T-9. See below for Grizzly model numbers:

- G2871—Boeshield® T-9 12 oz Spray
- G2870—Boeshield® T-9 4 oz Spray
- H3788—G96® Gun Treatment 12 oz Spray
- H3789—G96® Gun Treatment 4.5 oz Spray

Lubrication

The quill and table use a rack and pinion assembly for movement. To ensure a smooth operation and a long life of these rack and pinion systems, lubricate as needed depending upon use.

Brush a small amount of multi-purpose grease on the rack near the pinion (see **Figure 28 & 29**). Move the table or quill up and down to distribute the grease.

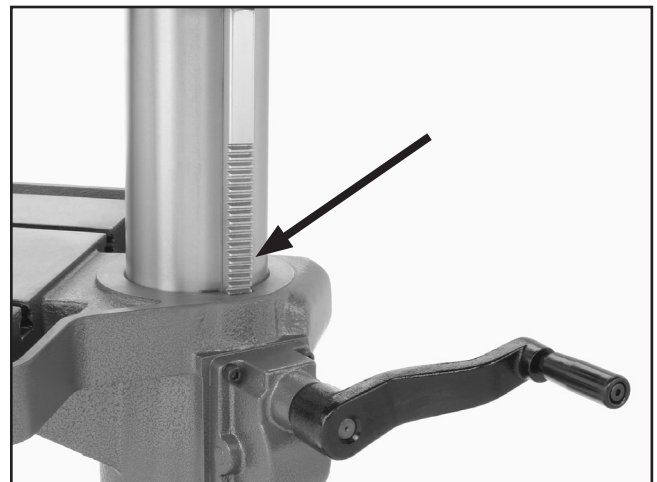

Figure 28. Table rack lubrication point.



Figure 29. Quill rack lubrication point.

Note: All other bearings are lubricated and sealed at the factory, and do not need further lubrication.

SECTION 7: SERVICE

About Service

This section is provided for your convenience—it is not a substitute for the Grizzly Service Department. If you need help troubleshooting, need replacement parts, or are unsure how to perform the procedures in this section, then feel free to call our Technical Support at (570) 546-9663.

Troubleshooting

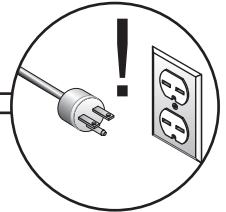

Motor & Electrical

Symptom	Possible Cause	Possible Solution
Machine does not start or a breaker trips.	<ol style="list-style-type: none"> 1. Plug or receptacle is at fault or wired incorrectly. 2. Cable or wiring is open or has high resistance. 3. Power supply is faulty, or is switched OFF. 4. Rotary switch at fault. 5. Motor connection is wired incorrectly. 6. Motor is at fault. 	<ol style="list-style-type: none"> 1. Test power plug and receptacle for good contact and correct wiring. 2. Troubleshoot wires for internal or external breaks, check for disconnected or corroded connections and repair or replace wiring, as necessary. 3. Make sure all hot lines and grounds are operational and have correct voltage on all legs. 4. Replace faulty switch. 5. Correct motor wiring (see Wiring Diagram on Page 30). 6. Test, repair or replace motor.
Machine stalls or is under-powered.	<ol style="list-style-type: none"> 1. Incorrect drilling speed or feed rate. 2. Machine is undersized for the task. 3. Bit or cutter is too large for machine. 4. Belt is slipping. 5. Plug or receptacle is at fault. 6. Pulley is slipping on shaft. 7. Motor bearings are at fault. 8. Motor has overheated. 9. Motor connection is wired incorrectly. 10. Motor is at fault. 	<ol style="list-style-type: none"> 1. Decrease drilling speed or feed rate. 2. Use smaller drill bits/cutters and reduce the feed rate and spindle speed. 3. Use a smaller bit or cutter. 4. Replace, realign, or re-tension belt. 5. Test power plug and receptacle for good contact and correct wiring. 6. Replace loose pulley and shaft. 7. Rotate motor shaft for noisy or burnt bearings, repair/replace as required. 8. Clean dust off motor, let it cool, and reduce workload on machine. 9. Correct motor wiring (see Wiring Diagram on Page 30). 10. Test, repair or replace motor.



Symptom	Possible Cause	Possible Solution
Machine vibrates excessively or is unusually noisy.	<ol style="list-style-type: none"> 1. Motor fan is rubbing on fan cover. 2. Motor or component is loose. 3. Belt is slapping belt housing. 4. V-belt is worn. 5. Pulley is loose. 6. Machine is incorrectly mounted to the stand, stand is incorrectly mounted to the floor, or the stand is uneven. 7. Chuck or cutter is at fault. 8. Motor bearings are at fault. 9. Spindle bearings at fault. 	<ol style="list-style-type: none"> 1. Replace/repair dented fan cover, and replace loose or damaged fan. 2. Replace component fasteners and re-tighten with thread locking fluid. 3. Replace, realign, or re-tension belt. 4. Replace belt. 5. Remove pulley, replace with key as required, and re-install securely. 6. Make sure the mounting hardware is tight; place shims under machine. 7. Replace out-of-round chuck, replace or sharpen cutter, use appropriate feed rate and cutting RPM. 8. Check bearings, replace motor or bearings as required. 9. Replace bearings.

Drill Operations

Symptom	Possible Cause	Possible Solution
Drilling stops, but the motor still operates.	<ol style="list-style-type: none"> 1. The belt is loose, worn, or broken. 2. Bit slips in chuck. 3. Pully slips on shaft. 	<ol style="list-style-type: none"> 1. Replace, realign, or re-tension belt. 2. Tighten bit; inspect bit for burrs or other obstructions that might interfere with clamping surface. 3. Remount or replace pulley and shaft.
The chuck wobbles or is loose on the spindle shaft.	<ol style="list-style-type: none"> 1. Foreign material is stuck between the chuck-to-spindle mating surface. 2. Damaged chuck. 	<ol style="list-style-type: none"> 1. Remove the chuck, clean, and de-burr the tapered chuck and spindle mating surfaces, then reassemble. 2. Replace.
The spindle does not retract completely in the uppermost position or it binds.	<ol style="list-style-type: none"> 1. The quill shaft is gummy with sawdust and oil. 2. The quill lock is locked or not fully released. 3. The feed shaft return spring is weak. 	<ol style="list-style-type: none"> 1. Clean shaft and lubricate with a light coat of oil. 2. Fully release the quill lock. 3. Replace the feed shaft return spring.
The quill has excessive deflection.	<ol style="list-style-type: none"> 1. The quill bearings are worn or damaged. 2. The quill shaft is at fault. 	<ol style="list-style-type: none"> 1. Replace the bearings. 2. Replace the quill shaft.
Drill bit wobbles, holes are oversized.	<ol style="list-style-type: none"> 1. Drill bit installed incorrectly. 	<ol style="list-style-type: none"> 1. Remove drill bit and reinstall.



Electrical Components

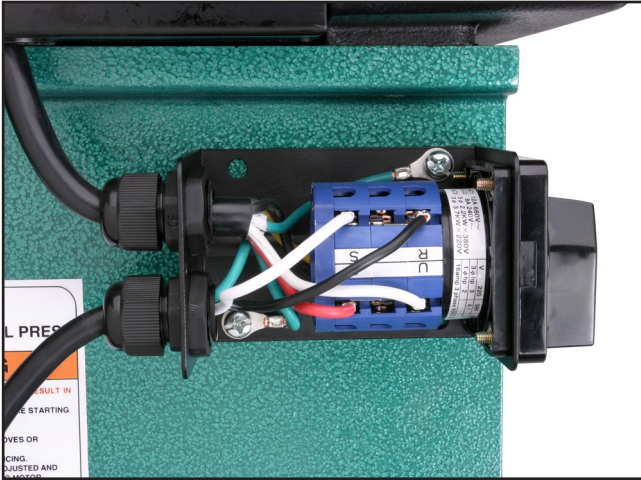

Figure 30. G9749 switch wiring.

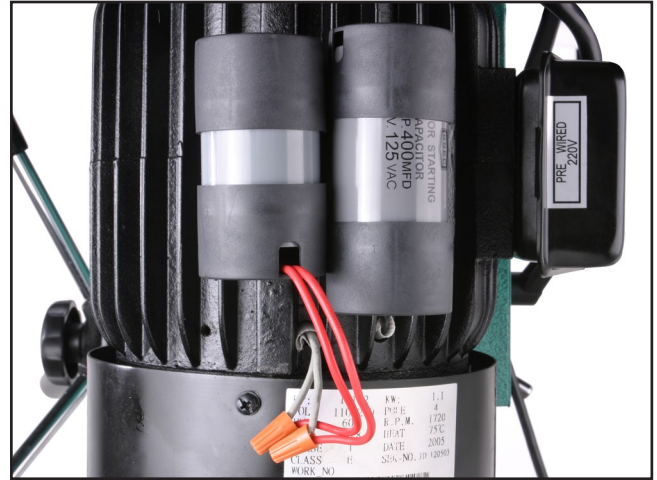

Figure 32. G9749 motor capacitors.

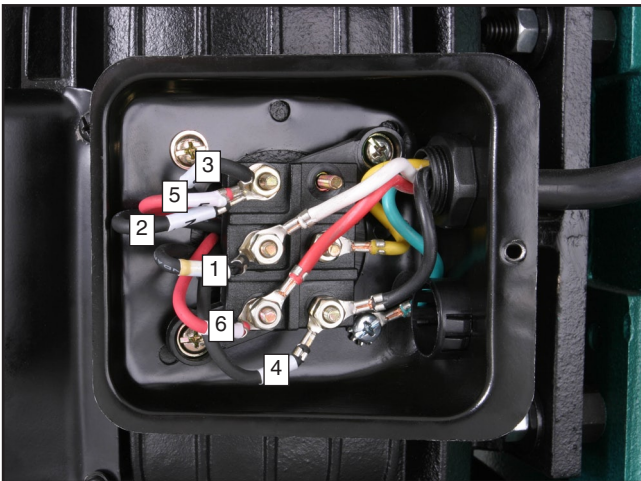
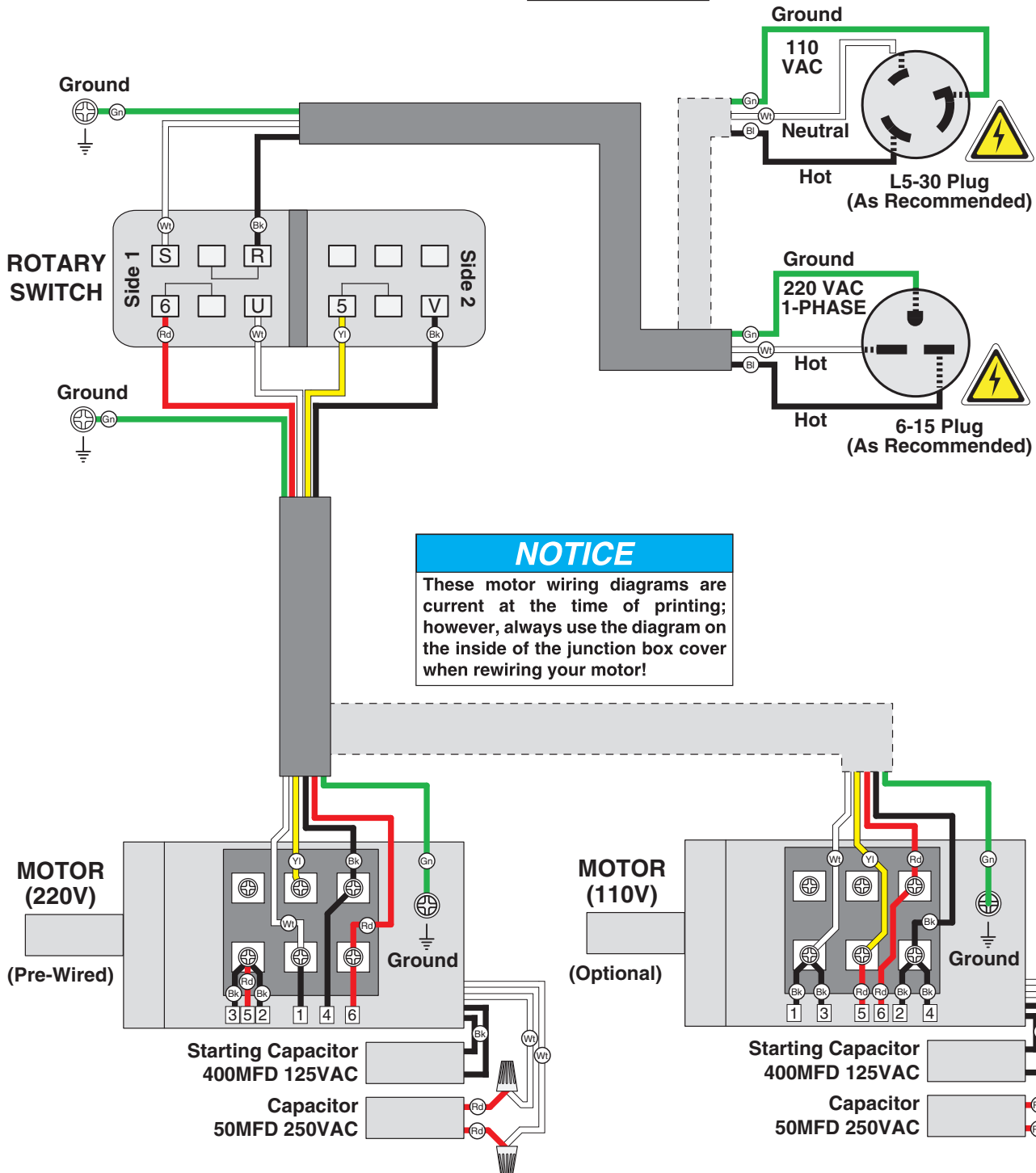

Figure 31. G9749 motor wiring (220V).

Wiring Diagram



COLOR KEY	
BLACK	Bk
WHITE	Wh
GREEN	Gn
RED	Rd
YELLOW	Yl



Headstock Parts Breakdown

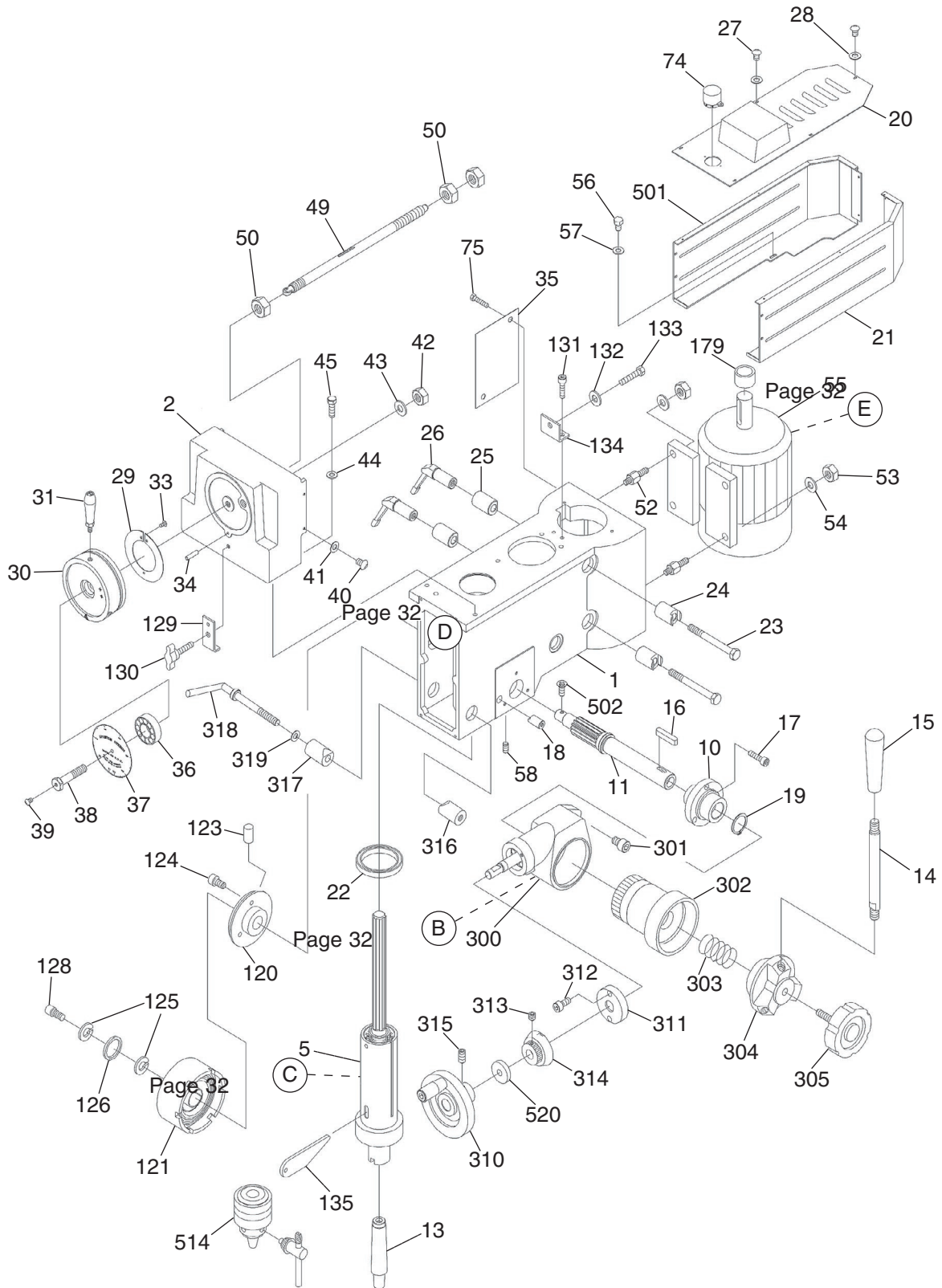

Headstock Components Parts Breakdown

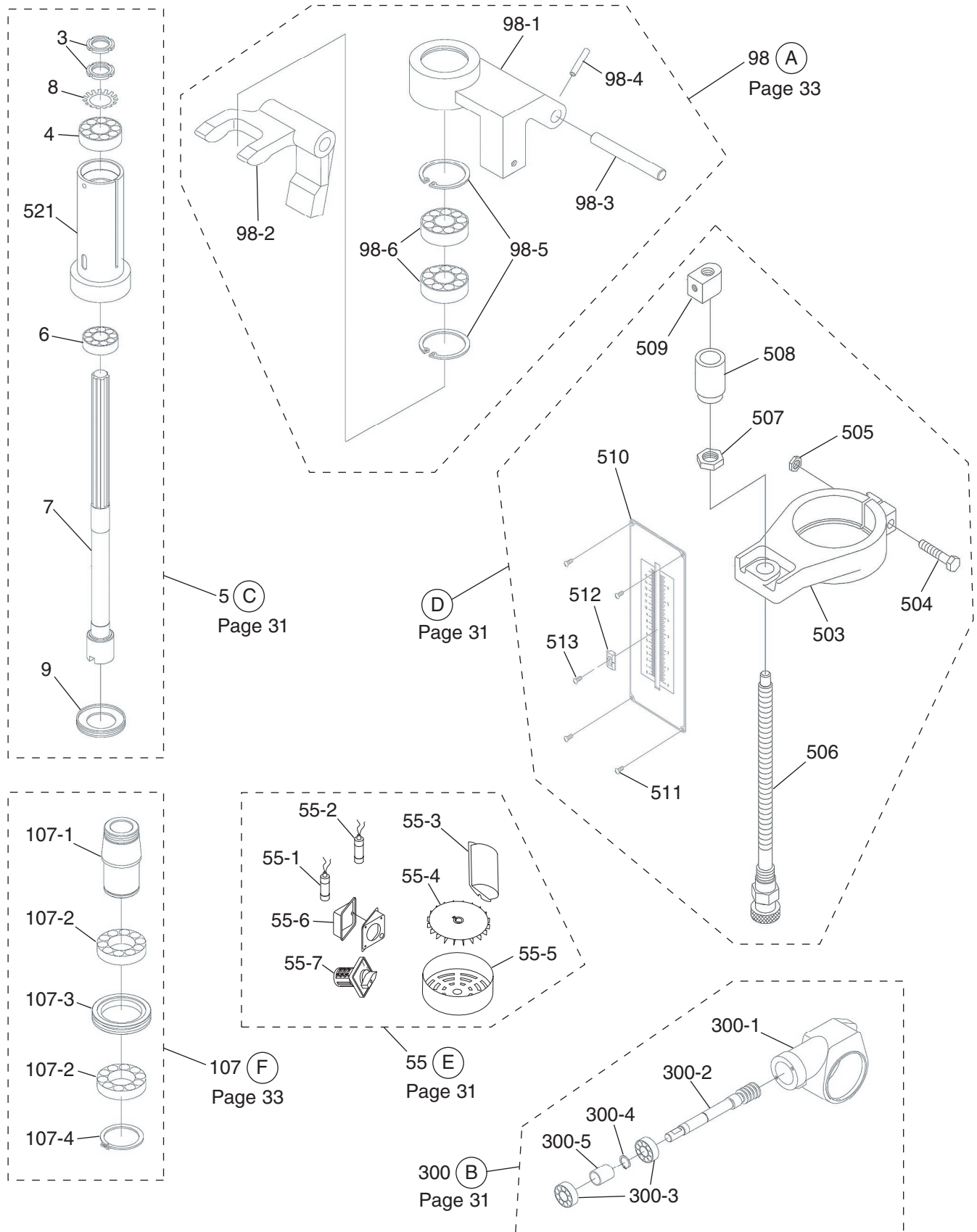

Variable Speed Parts Breakdown

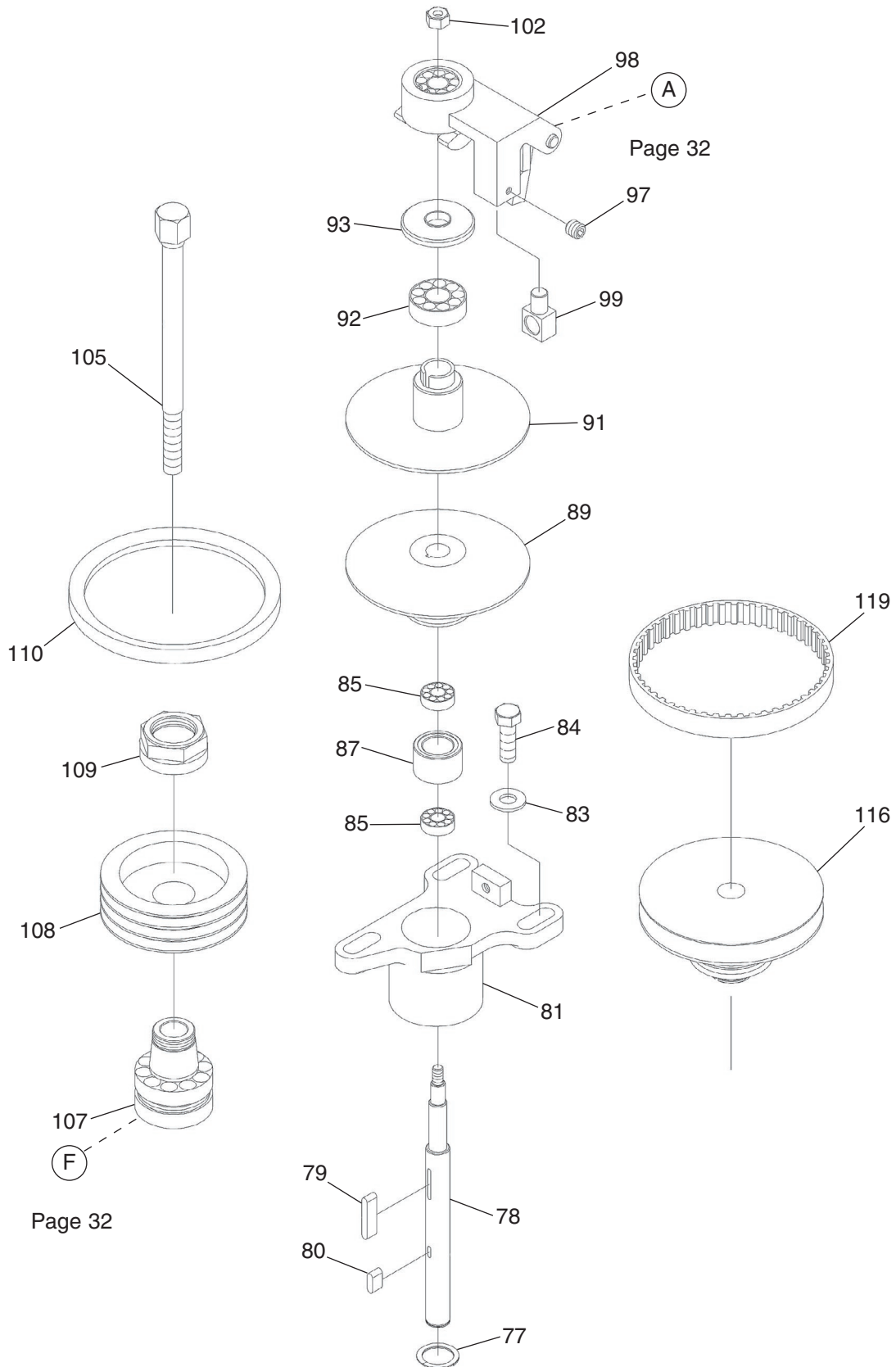

Base Parts Breakdown

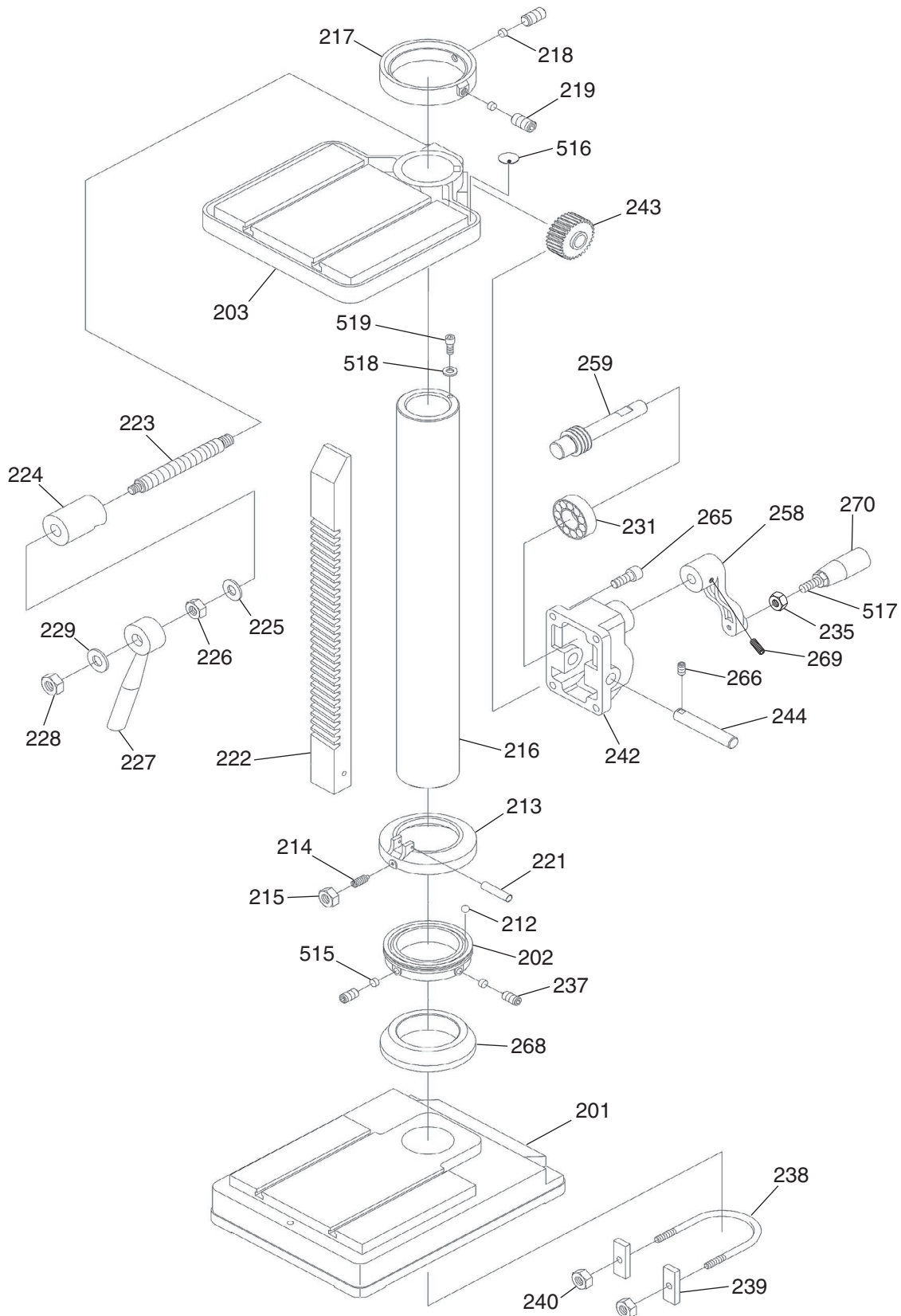

Parts List

REF	PART #	DESCRIPTION
1	P9749001	HEAD BODY
2	P9749002	SPINDLE COVER
3	P9749003	BEARING NUT
4	P6206	BALL BEARING 6206ZZ
5	P9749005	QUILL ASSEMBLY
6	P30207	TAPERED ROLLER BEARING 30207
7	P9749007	SPINDLE SHAFT
8	P9749008	BEARING WASHER
9	P9749009	BEARING CAP
10	P9749010	PINION SUPPORT
11	P9749011	PINION SHAFT
13	P9749013	MT3 3/8-16 CHUCK ARBOR
14	P9749014	HANDLE ROD
15	P9749015	HANDLE KNOB
16	PK25M	KEY 7 X 7 X 20
17	PSB05	CAP SCREW 1/4-20 X 3/4
18	P9749018	PIN
19	PR62M	EXT RETAINING RING 42MM
20	P9749020	HEAD COVER UPPER
21	P9749021	HEAD COVER RIGHT
22	P9749022	RUBBER FLANGE
23	P9749023	HEX BOLT 1/2-13 X 5
24	P9749024	HEAD LOCK
25	P9749025	FIXED TIGHT COLLAR
26	P9749026	LOCK HANDLE
27	PS05M	PHLP HD SCR M5-.8 x 8
28	PW02M	FLAT WASHER 5MM
29	P9749029	CAM SPRING
30	P9749030	HUB
31	P9749031	HANDLE
33	PS06	PHLP HD SCR 10-24 X 3/8
34	PRP03M	ROLL PIN 5 X 20
35	P9749035	PLATE
36	P51101	THRUST BEARING 51101
37	P9749037	SPEED CHART
38	P9749038	SPECIAL HEX BOLT
39	PS04	PHLP HD SCR 1/4-20 X 1/2
40	PS05M	PHLP HD SCR M5-.8 x 8
41	PW02M	FLAT WASHER 5MM
42	PN09M	HEX NUT M12-1.75
43	PW06M	FLAT WASHER 12MM
44	PW04	FLAT WASHER 7/16
45	PB90	HEX BOLT 7/16-14 X 1-1/4
49	P9749049	PUSH ROD TUBE
50	PN09	HEX NUT 5/8-18
52	P9749052	PIVOT SHAFT
53	PN08	HEX NUT 3/8-16
54	PW02	FLAT WASHER 3/8
55	P9749055	1-1/2HP 110V/220V 1PH MOTOR
55-1	P9749055-1	CAPACITOR 50MFD 250VAC

REF	PART #	DESCRIPTION
55-2	P9749055-2	START CAP 400MFD 125VAC
55-3	P9749055-3	CAPACITOR COVER
55-4	P9749055-4	MOTOR FAN
55-5	P9749055-5	MOTOR FAN COVER
55-6	P9749055-6	MOTOR JUNCTION BOX
55-7	P9749055-7	POWER SWITCH
56	PB09	HEX BOLT 5/16-18 X 1/2
57	PW07	FLAT WASHER 5/16
58	PSS06	SET SCREW 1/4-20 X 3/4
74	P9749074	SPINDLE COVER
75	PB09	HEX BOLT 5/16-18 X 1/2
77	PR11M	EXT RETAINING RING 25MM
78	P9749078	SHAFT
79	P9749079	KEY 5 X 10 X 38
80	PK06M	KEY 5 X 5 X 10
81	P9749081	BEARING HOUSING
83	PW04	FLAT WASHER 7/16
84	PB90	HEX BOLT 7/16-14 X 1-1/4
85	P6205	BALL BEARING 6205ZZ
87	P9749087	SPACER RING
89	P9749089	LOWER VS PULLEY
91	P9749091	UPPER VS PULLEY
92	P6207	BALL BEARING 6207ZZ
93	P9749093	BEARING CAP
97	PSS17	SET SCREW 5/16-18 X 5/16
98	P9749098	SPEED CONTROL ASSY
98-1	P9749098-1	SPEED CONTROL HOUSING
98-2	P9749098-2	SPEED CONTROL FORK
98-3	P9749098-3	HINGE PIN
98-4	PRP16M	ROLL PIN 3 X 25
98-5	PR24M	INT RETAINING RING 42MM
98-6	P9749098-6	BALL BEARING 6302ZZ
99	P9749099	SUPPORT SWIVEL
102	PN10	HEX NUT 7/16-20
105	P9749105	DRAWBAR MT3 3/8
107	P9749107	SPINDLE TAPER ASSY
107-1	P9749107-1	SPINDLE TAPER SLEEVE
107-2	P6009	BALL BEARING 6009ZZ
107-3	P9749107-3	BEARING SPACER SLEEVE
107-4	PR56M	EXT RETAINING RING 45MM
108	P9749108	SPINDLE PULLEY
109	P9749109	SPINDLE LOCKNUT
110	PVA25	V-BELT A-25 4L250
116	P9749116	UPPER MOTOR PULLEY
119	P9749119	1926v-427 TIMING BELT
120	P9749120	SPRING BASE
121	P9749121	SPRING ASSEMBLY
123	P9749123	COTTER PIN 3 X 12
124	PS08	PHLP HD SCR 10-24 X 3/4
125	PLW02	LOCK WASHER 1/4



Parts List

REF	PART #	DESCRIPTION
126	PW06	FLAT WASHER 1/4
128	PSB01	CAP SCREW 1/4-20 X 5/8
129	P9749129	LOCKING PLATE
130	P9749130	T-SCREW 5/16-18 X 1
131	PB02	HEX BOLT 1/4-20 X 5/8
132	PW07	FLAT WASHER 5/16
133	PB11	HEX BOLT 5/16-18 X 1-1/2
134	P9749134	SUPPORT
135	P9749135	DRIFT KEY
179	P9749179	BUSHING
201	P9749201	BASE
202	P9749202	BEARING COVER
203	P9749203	SQUARE WORKING TABLE
212	P9749212	STEEL BALL
213	P9749213	BEARING COVER
214	P9749214	SPECIAL SCREW
215	PN02	HEX NUT 5/16-18
216	P9749216	COLUMN BASE
217	P9749217	HEAD BODY BASE
218	P9749218	BUSHING
219	P9749219	SET SCREW 1/2-13 X 5/8
221	PRP82M	ROLL PIN 5 X 38
222	P9749222	RACK
223	P9749223	SPECIAL LOCK BOLT
224	P9749224	LOCK BLOCK
225	PW14	FLAT WASHER 5/8
226	PN04	HEX NUT 5/8-11
227	P9749227	LEVER HANDLE
228	PN08	HEX NUT 3/8-16
229	PW02	FLAT WASHER 3/8
231	P51103	THRUST BEARING 51103
235	PN08	HEX NUT 3/8-16
237	P9749237	SET SCREW 1/2-13 x 5/8
238	P9749238	U-BOLT
239	P9749239	FIXED BLOCK
240	PN06	HEX NUT 1/2-12
242	P9749242	ELEVATION BRACKET
243	P9749243	TRANSMISSION GEAR
244	P9749244	SHAFT
258	P9749258	HEAD HANDLE
259	P9749259	WORM SHAFT
265	PSB03	CAP SCREW 5/16-18 X 1
266	PSS03	SET SCREW 1/4-20 X 3/8
268	P9749268	BUSHING BRACKET

REF	PART #	DESCRIPTION
269	PSS17	SET SCREW 5/16-18 X 5/16
270	P9749270	HANDLE
300	P9749300	FEED ASSEMBLY
300-1	P9749300-1	FEED HOUSING
300-2	P9749300-2	WORM SHAFT
300-3	P6202	BALL BEARING 6202ZZ
300-4	PR05M	EXT RETAINING RING 15MM
300-5	P9749300-5	BEARING SPACER
301	PSB07	CAP SCREW 5/16-18 X 3/4
302	P9749302	TRANSMISSION GEAR
303	P9749303	COMPRESSION SPRING
304	P9749304	UP DOWN HANDLE
305	P9749305	LOCK BOLT WITH KNOB
310	P9749310	HAND WHEEL
311	P9749311	WORM COVER
312	PSB02	CAP SCREW 10-24 X 3/8
313	PSS04	SET SCREW 1/4-20 X 5/16
314	P9749314	ADJUSTING INDICATOR
315	PSS17	SET SCREW 5/16-18 X 5/16
316	P9749316	FIXED TIGHT COLLAR
317	P9749317	FIXED TIGHT COLLAR
318	P9749318	HANDLE ROD
319	PW01	FLAT WASHER 1/2
501	P9749501	HEAD COVER LEFT
502	PFH01	FLAT HD SCR 10-24 X 3/8
503	P9749503	ELEVATION BASE
504	PB06	HEX BOLT 5/16-18 X 2
505	PN02	HEX NUT 5/16-18
506	P9749506	ELEVATION SHAFT
507	P9749507	ELEVATION NUT
508	P9749508	BUSHING
509	P9749509	DEPTH INDICATOR BRACKET
510	P9749510	DEPTH SCALE
511	PS18	PHLP HD SCR 10-24 X 1/4
512	P9749512	DEPTH INDICATOR
513	PS18	PHLP HD SCR 10-24 X 1/4
514	P9749514	CHUCK W/KEY
515	P9749515	BUSHING
516	P9749516	FILTER
517	P9749517	CAP SCREW 3/8-16 X 3-1/2
518	PW03M	FLAT WASHER 6MM
519	PSB68M	CAP SCREW M6-1 X 8
520	P9749520	BUSHING
521	P9749521	QUILL HOUSING



Label Placement

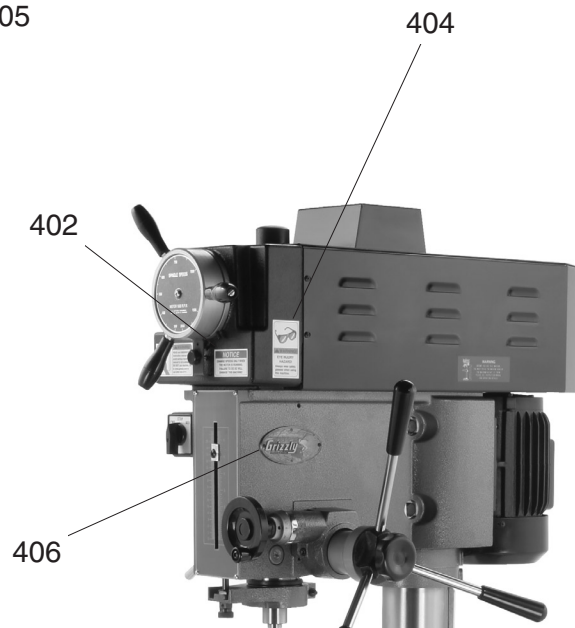
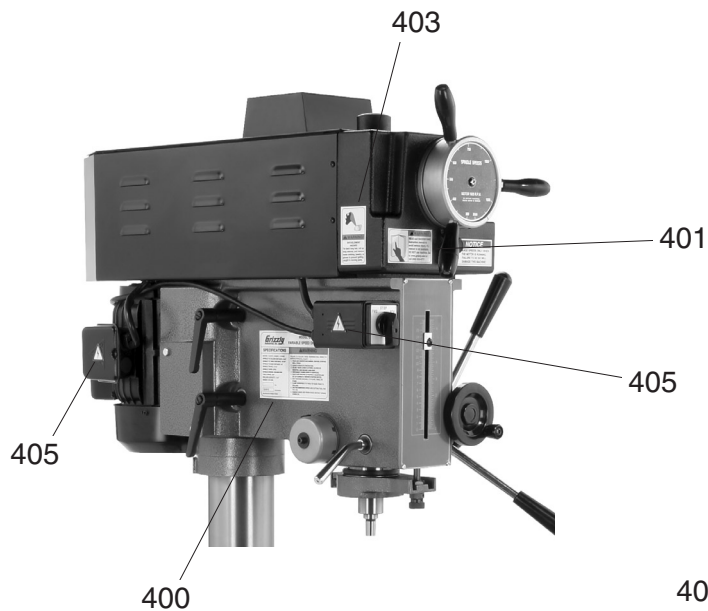

REF	PART #	DESCRIPTION
400	P9749400	MACHINE ID LABEL
401	P9749401	READ MANUAL-HORIZONTAL
402	P9749402	SPEED NOTICE LABEL
403	P9749403	ENTANGLEMENT LABEL

REF	PART #	DESCRIPTION
404	PLABEL-11	SAFETY GLASSES 2" X 3 5/16"
405	PLABEL-14	ELECTRICITY LABEL
406	PLABEL-10	GRIZZLY NAME PLATE
407	PPAINT-1	GRIZZLY GREEN PAINT

WARNING

Safety labels warn about machine hazards and ways to prevent injury. The owner of this machine **MUST** maintain the original location and readability of the labels on the machine. If any label is removed or becomes unreadable, **REPLACE** that label before using the machine again. Contact Grizzly at (800) 523-4777 or www.grizzly.com to order new labels.

WARRANTY AND RETURNS

Grizzly Industrial, Inc. warrants every product it sells for a period of **1 year** to the original purchaser from the date of purchase. This warranty does not apply to defects due directly or indirectly to misuse, abuse, negligence, accidents, repairs or alterations or lack of maintenance. This is Grizzly's sole written warranty and any and all warranties that may be implied by law, including any merchantability or fitness, for any particular purpose, are hereby limited to the duration of this written warranty. We do not warrant or represent that the merchandise complies with the provisions of any law or acts unless the manufacturer so warrants. In no event shall Grizzly's liability under this warranty exceed the purchase price paid for the product and any legal actions brought against Grizzly shall be tried in the State of Washington, County of Whatcom.

We shall in no event be liable for death, injuries to persons or property or for incidental, contingent, special, or consequential damages arising from the use of our products.

To take advantage of this warranty, contact us by mail or phone and give us all the details. We will then issue you a "Return Number," which must be clearly posted on the outside as well as the inside of the carton. We will not accept any item back without this number. Proof of purchase must accompany the merchandise.

The manufacturers reserve the right to change specifications at any time because they constantly strive to achieve better quality equipment. We make every effort to ensure that our products meet high quality and durability standards and we hope you never need to use this warranty.

Please feel free to write or call us if you have any questions about the machine or the manual.

Thank you again for your business and continued support. We hope to serve you again soon.





WARRANTY CARD

Name _____

Street _____

City _____ State _____ Zip _____

Phone # _____ Email _____ Invoice # _____

Model # _____ Order # _____ Serial # _____

The following information is given on a voluntary basis. It will be used for marketing purposes to help us develop better products and services. **Of course, all information is strictly confidential.**

1. How did you learn about us?

____ Advertisement

____ Friend

____ Catalog

____ Card Deck

____ Website

____ Other:

2. Which of the following magazines do you subscribe to?

____ Cabinet Maker

____ Popular Mechanics

____ Today's Homeowner

____ Family Handyman

____ Popular Science

____ Wood

____ Hand Loader

____ Popular Woodworking

____ Wooden Boat

____ Handy

____ Practical Homeowner

____ Woodshop News

____ Home Shop Machinist

____ Precision Shooter

____ Woodsmith

____ Journal of Light Cont.

____ Projects in Metal

____ Woodwork

____ Live Steam

____ RC Modeler

____ Woodworker West

____ Model Airplane News

____ Rifle

____ Woodworker's Journal

____ Modeltec

____ Shop Notes

____ Other:

____ Old House Journal

____ Shotgun News

3. What is your annual household income?

____ \$20,000-\$29,000

____ \$30,000-\$39,000

____ \$40,000-\$49,000

____ \$50,000-\$59,000

____ \$60,000-\$69,000

____ \$70,000+

4. What is your age group?

____ 20-29

____ 30-39

____ 40-49

____ 50-59

____ 60-69

____ 70+

5. How long have you been a woodworker/metalworker?

____ 0-2 Years

____ 2-8 Years

____ 8-20 Years

____ 20+ Years

6. How many of your machines or tools are Grizzly?

____ 0-2

____ 3-5

____ 6-9

____ 10+

7. Do you think your machine represents a good value?

____ Yes

____ No

8. Would you recommend Grizzly Industrial to a friend?

____ Yes

____ No

9. Would you allow us to use your name as a reference for Grizzly customers in your area?

Note: We never use names more than 3 times.

____ Yes

____ No

10. Comments: _____

CUT ALONG DOTTED LINE

FOLD ALONG DOTTED LINE



Place
Stamp
Here



GRIZZLY INDUSTRIAL, INC.
P.O. BOX 2069
BELLINGHAM, WA 98227-2069



FOLD ALONG DOTTED LINE

Send a Grizzly Catalog to a friend:

Name _____

Street _____

City _____ State _____ Zip _____

TAPE ALONG EDGES--PLEASE DO NOT STAPLE

grizzly.com

TOOL WEBSITE

Buy Direct and Save with Grizzly® – Trusted, Proven and a Great Value!

*Visit Our Website Today And Discover
Why Grizzly® Is The Industry Leader!*

- SECURE ORDERING
- ORDERS SHIPPED WITHIN 24 HOURS
- E-MAIL RESPONSE WITHIN ONE HOUR

-OR-

Call Today For A **FREE**
Full Color Catalog

1-800-523-4777



Free Manuals Download Website

<http://myh66.com>

<http://usermanuals.us>

<http://www.somanuals.com>

<http://www.4manuals.cc>

<http://www.manual-lib.com>

<http://www.404manual.com>

<http://www.luxmanual.com>

<http://aubethermostatmanual.com>

Golf course search by state

<http://golfingnear.com>

Email search by domain

<http://emailbydomain.com>

Auto manuals search

<http://auto.somanuals.com>

TV manuals search

<http://tv.somanuals.com>