

Grizzly **Industrial**®

RADIAL DRILL PRESS MODEL G1131 INSTRUCTION MANUAL

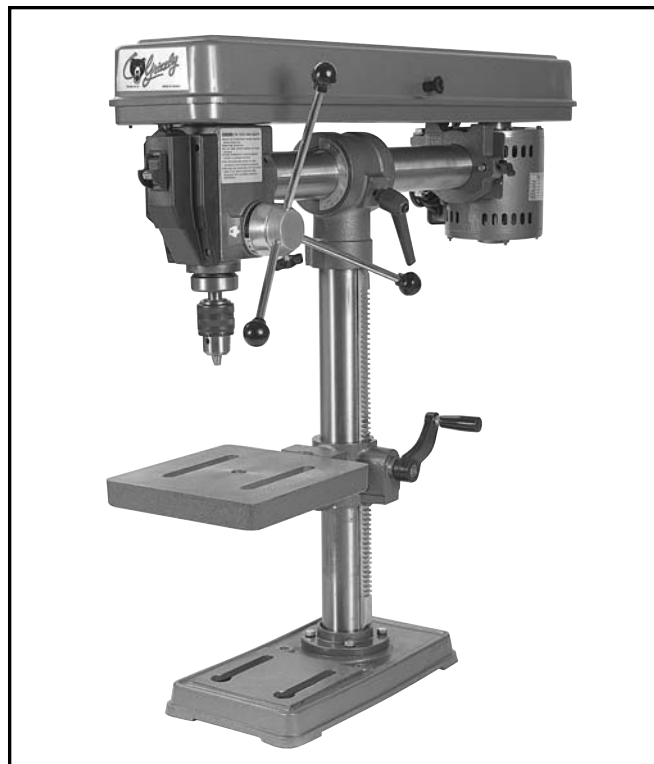

1995 BY GRIZZLY IMPORTS, INC.

**WARNING: NO PORTION OF THIS MANUAL MAY BE REPRODUCED IN ANY SHAPE
OR FORM WITHOUT THE WRITTEN APPROVAL OF GRIZZLY IMPORTS, INC.**

OCTOBER, 1995. PRINTED IN USA

DISCONTINUED MACHINE MANUAL DISCLAIMER

THE INFORMATION IN THIS MANUAL REPRESENTS THE LAST CONFIGURATION OF THE MACHINE BEFORE IT WAS DISCONTINUED. MACHINE CONFIGURATIONS MAY HAVE CHANGED AS PRODUCT IMPROVEMENTS WERE INCORPORATED. IF YOU OWN AN EARLIER VERSION OF THE MACHINE, THIS MANUAL MAY NOT EXACTLY DEPICT YOUR MACHINE. CONTACT CUSTOMER SERVICE IF YOU HAVE ANY QUESTIONS ABOUT DIFFERENCES. PREVIOUS VERSIONS ARE NOT AVAILABLE ONLINE.

WARNING

Some dust created by power sanding, sawing, grinding, drilling, and other construction activities contains chemicals known to the State of California to cause cancer, birth defects or other reproductive harm. Some examples of these chemicals are:

- Lead from lead-based paints.
- Crystalline silica from bricks, cement, and other masonry products.
- Arsenic and chromium from chemically treated lumber.

Your risk from these exposures varies, depending on how often you do this type of work. To reduce your exposure to these chemicals: work in a well ventilated area, and work with approved safety equipment, such as those dust masks that are specially designed to filter out microscopic particles.

Section 1:

Introduction To The Model G1131 Radial Drill Press

Grizzly Imports, Inc. is proud to offer the Model G1131 Radial Drill Press. When used according to the guidelines stated in this manual, you can expect years of trouble-free, enjoyable operation from this fine machine.

The Model G1131 is intended for home and medium-duty professional use. It features a 1,720 R.P.M., 1/2 HP capacitor-start motor, ON/OFF switch with a removable security lock, and heavy-duty cast iron table and base for long-lasting dependability.

The single-phase, 110V motor uses shielded ball bearings, which require no lubrication for the life of the bearings. The belt-driven spindle assembly features 5 speeds, ranging from 580 to 3,000 RPM. Power is transferred to your workpiece via a 1/2" key-adjustable chuck.

This manual is designed to offer tips on safety and proper operating procedures, as well as providing you with detailed parts lists and diagrams. If you have any questions or criticisms regarding the Model G1131 or this manual, please direct them to:

Manager, Technical Documentation
Grizzly Industrial, Inc.
P.O. Box 2069
Bellingham, WA 98227-2069

Most importantly, we stand behind our machines. We have two excellent regional service departments available, should the need arise. If you have any service questions or parts requests, please call or write the appropriate location listed below.

Grizzly Industrial, Inc.
1203 Lycoming Mall Circle
Muncy, PA 17756
Phone:(570) 546-9663
Fax:(800) 438-5901
E-Mail: techsupport@grizzly.com
Web Site: <http://www.grizzly.com>

To operate this, or any power tool, safely and efficiently, it is essential to become as familiar with it as possible. The time you invest before you begin to use your Model G1131 will be time well spent. **DO NOT** operate this machine until you are completely familiar with the contents of this manual.

REMEMBER: ALWAYS WEAR ANSI-APPROVED EYEWEAR AND HEARING PROTECTION WHEN OPERATING THIS, OR ANY OTHER SHOP MACHINERY.

The specifications, drawings, and photographs illustrated in this manual represent the Model G1131 as supplied when the manual was prepared. However, due to Grizzly's policy of continuous improvement, changes or modifications may be made at any time with no obligation on the part of Grizzly. Whenever possible though, we send manual updates to all owners of a particular tool or machine. Should you receive one, add the new information to this manual and keep it for later reference.

The information in this manual has been obtained from sources we believe to be reliable and as up-to-date as possible. We have included some important safety measures which are essential to this machine's operation. While most safety measures are generally universal, Grizzly reminds you that each workshop is different and safety rules should be considered *as they apply to your specific situation*.

We recommend you keep a copy of our current catalog for complete information regarding Grizzly warranty and return policy. If you need additional technical information relating to this machine, or if you need gen-

eral assistance or replacement parts, please contact the appropriate regional service department listed in the introduction.

Additional information sources are necessary to realize the full potential of this machine. Trade journals, woodworking magazines, and your local library are good places to start.

WARNING!

Like all power tools, there is danger associated with the Model G1131 Radial Drill Press. Use the tool with respect and caution to lessen the possibility of mechanical damage or operator injury. If normal safety precautions are overlooked or ignored, injury to the operator or others in the area is possible.

The Model G1131 was specifically designed for precision drilling operations in wood and metal. **DO NOT MODIFY AND/OR USE THIS DRILL PRESS FOR ANY OTHER PURPOSE. Modifications or improper use of this tool will void the warranty.** If you are confused about any aspect of this machine, **DO NOT** use it until you have answered all your questions.

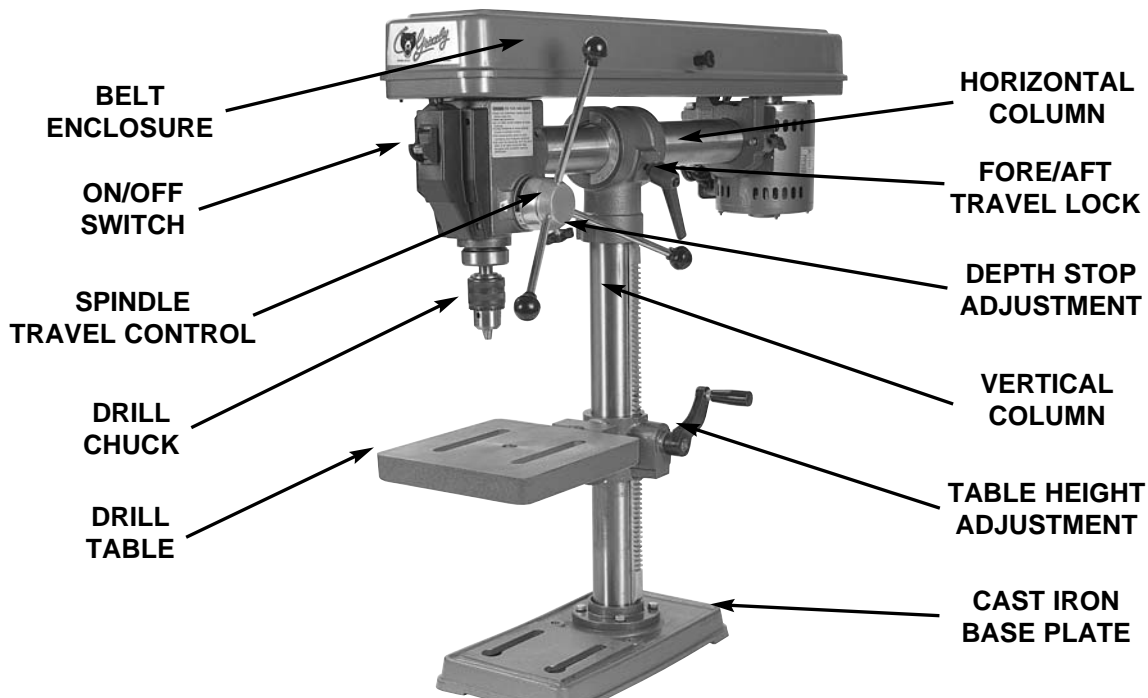

Section 2:

Safety Guidelines

- 1. KNOW YOUR POWER TOOL.** Read the owner's manual carefully. Learn the tool's applications and limitations, as well as its particular hazards.
- 2. KEEP ALL GUARDS IN PLACE** and in working order.
- 3. GROUND ALL TOOLS.** If an adapter is used to accommodate a two-prong receptacle, the adapter plug must be attached to a known ground. Never remove the grounding prong.
- 4. REMOVE ADJUSTING KEYS AND WRENCHES.** Make it a habit to check that keys and wrenches are removed from the machine before turning it on.
- 5. KEEP WORK AREA CLEAN.** Cluttered areas and benches invite accidents.
- 6. AVOID DANGEROUS ENVIRONMENTS.** Do not use power tools in damp or wet locations or expose them to rain. Keep your work area well lighted.
- 7. KEEP CHILDREN AND VISITORS AWAY.** All children and visitors should be kept a safe distance away from your work area.
- 8. MAKE WORKSHOP CHILD-PROOF** with padlocks, master switches, or by removing starter keys.
- 9. DO NOT FORCE TOOL.** Tools work better and safer when they are allowed to perform at their own speed. A speed chart located in this manual offers specific guidelines for drilling operations.
- 10. WEAR PROPER APPAREL.** Do not wear loose clothing, gloves, neckties, or jewelry that can get caught in moving parts. Non-slip footwear must be worn. Tie back, or wear a hat over long hair.
- 11. NEVER STAND ON, OR LEAN ON THE TABLE SAW.**
- 12. USE SAFETY GLASSES AND EAR PROTECTION.** Also use a **DUST MASK** if the cutting operation is dusty.
- 13. DO NOT OVERREACH.** Keep proper footing and balance at all times.
- 14. MAINTAIN TOOLS IN TOP CONDITION.** Keep tools sharp and clean for best and safest performance. Follow instructions for lubricating and changing accessories.
- 15. DISCONNECT TOOLS FROM POWER** before servicing and when changing accessories, such as blades, bits, and cutters.
- 16. AVOID ACCIDENTAL STARTING.** Make sure the switch is in the "OFF" position before plugging in the cord.
- 17. CHECK DAMAGED PARTS.** Do not operate the machine until you are certain it is in perfect running condition.
- 18. NEVER LEAVE THE TOOL RUNNING UNATTENDED - TURN POWER OFF.** Do not leave the tool until it comes to a full stop.
- 19. DO NOT USE THE TOOL IF USING DRUGS, ALCOHOL, OR MEDICATION.**
- 20. DO NOT WORK IN HASTE** or operate machine if you are fatigued.
- 21. IF THERE IS SOMETHING YOU DO NOT KNOW OR UNDERSTAND ABOUT THIS TOOL, DO NOT OPERATE IT!** Ask for help first. Confusion can lead to disaster.
- 22. BAD HABITS ARE DANGEROUS.** Review all safety procedures often.

Section 3:

Controls And Adjustments

TABLE ADJUSTMENTS

HEIGHT ADJUSTMENT

Table height adjustment on the Model G1131 Radial Drill Press is controlled by a rack-and-pinion gearing system. To control the height of the table:

1. Release the locking lever on the rear of the table's gear housing, mounted on the vertical column.
2. Turn the adjustment crank clockwise or counterclockwise to achieve a desired table height.
3. Re-tighten the locking lever to keep the table from moving out of its desired position.

SIDE-TO-SIDE ADJUSTMENT

The table can be rotated from side-to-side, or completely 180° out of the way of spindle travel, so larger objects can be placed on the work surface built into the base of the drill press. To rotate the table:

1. Loosen the locking lever at the back of the table's gear housing.
2. Move the table to its desired position.
3. Re-tighten the locking lever.

ANGLE ADJUSTMENT

The table's angle relative to spindle travel can be adjusted to 45° left or right. To adjust the table tilt:

1. Loosen the hex bolt below the table support.
2. Tilt the table to the desired angle, using the gauge built into the table support.
3. Once the table is adjusted to the desired angle, re-tighten the bolt.

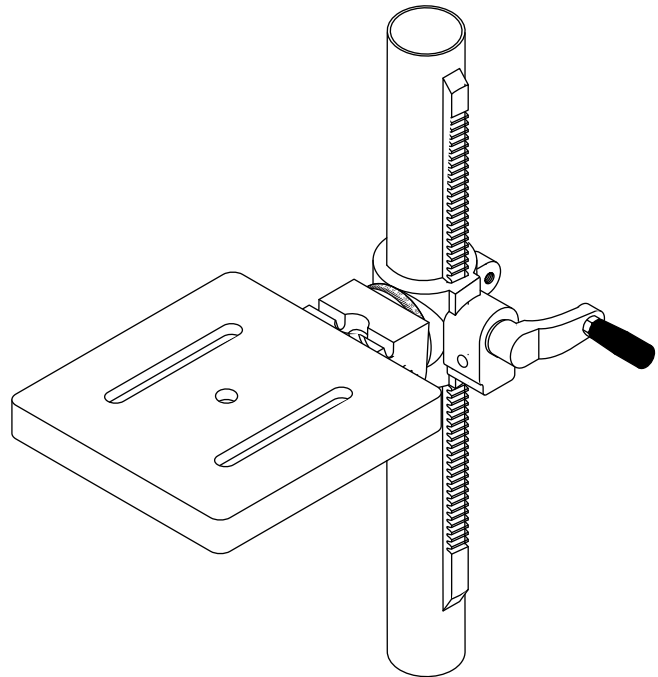

ON/OFF SWITCH

The Model G1131 Radial Drill Press is equipped with a key-activated ON/OFF switch for added safety. To switch on the drill press:

1. Insert the safety key into the switch mechanism located at the front of the spindle assembly.
2. Flip the key to the ON position.
3. When drilling is complete, switch the key to the OFF position. When the drill press is not in use, remove the key from the switch and store it in a safe place.

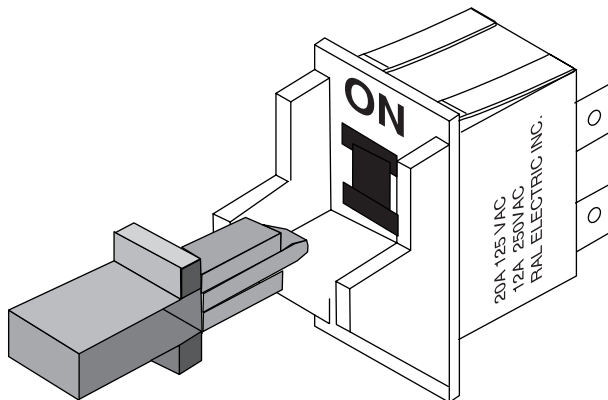

DEPTH STOP ADJUSTMENT

The Model G1131 Radial Drill Press offers an adjustable depth stop for precision control when making repetitive cuts to an exact depth. To set the depth stop:

1. Adjust your table so your workpiece is close enough to your drill bit to allow travel to the full depth of cut you desire.
2. Drill your first hole to the depth you seek.
3. Turn off the drill press and lower the spindle until the bit reaches the base of your cut. With one hand, maintain that depth.

4. Loosen the depth stop knob located at the hub of the spindle height wheel and rotate the depth scale counterclockwise until the pointer reaches zero.
5. Tighten the depth stop knob and release the height wheel.

Once the procedure is complete, your drill press will deliver uniformly deep holes until you choose to change your settings.

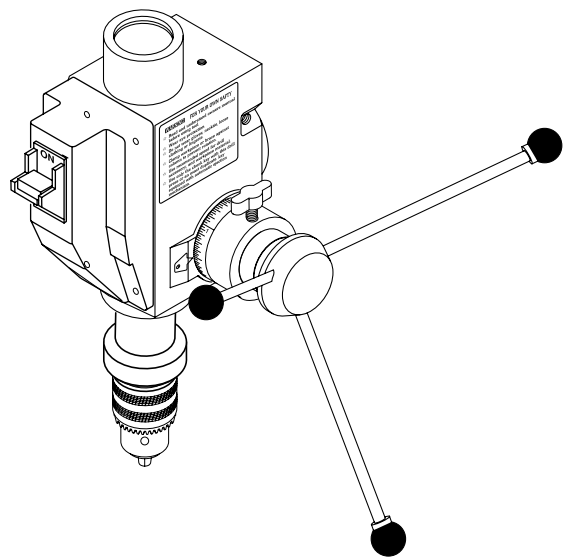

SPINDLE RETURN SPRING

Although the spring-operated spindle return is set at the factory, there may come a time when it's necessary to adjust its level of tightness.

Should adjustment be required, carefully loosen the two locknuts on the outside of the spring assembly (located on the spindle housing)

Firmly grasp the spring housing as you loosen the locknuts and gently pull the housing away from the spindle until the notches clear the retainer tab. Turn the housing clockwise – one notch at a time – until the proper tension is attained. Tighten the locknuts. Tighten the two nuts together using two wrenches.

SPINDLE SPEEDS

The Model G1131 features a five-speed belt drive system – so you can adjust drill speeds to match your project. To change spindle speeds:

1. Turn off and unplug the drill press and allow all moving parts to stop.
2. Loosen the tensioning knob located just forward of the motor mount.
3. Open the top of the belt housing and reduce tension on the belts by pushing the motor toward the front of the drill press.
4. Move the V-belt to a position that reflects the spindle speed you desire. See the illustration below for belt speeds. Always move the end of the belt that will move toward a smaller pulley first.
5. When you have relocated the belt, re-tension the motor mount. A properly tensioned belt will have about 1/2" of deflection mid-way between pulleys.
6. Tighten the tensioning knob and close the belt housing cover.

Never attempt to alter speeds by angling the belt between un-matched pulleys. Doing so could damage the belt and burn out bearings in the spindle assembly.

TILTING DRILL HEAD

Adjust the drill head up to 45° clockwise or counterclockwise by loosening the tilt lock knob on the right side of the horizontal column support. An angle guide at the front of the column support allows you to determine the angle of spindle travel.

Remember to square your spindle assembly to the table with a machinists or combination square when returning to the zero position.

ROTATING DRILL HEAD

The drill head on the Model G1131 Radial Drill Press can be rotated a full 360° to handle projects too large to fit on the table or base support. To rotate the head, loosen the 4mm setscrews on the left side of the horizontal column support. Once loosened, the drill head can be rotated to fit your project. Keep in mind, while rotating the head, that the electrical cord must turn along with the machine. Pay attention that the cord isn't pinched or snagged as a result of the rotation.

FORE/AFT MOVEMENT

The drill head on the Model G1131 Radial Drill Press can be moved to front and back to accommodate smaller or larger projects. To adjust, loosen the tilt lock knob and slide the horizontal column forward or backward to suit your needs. Remember to ensure that the spindle assembly is square to the table before operating the machine.

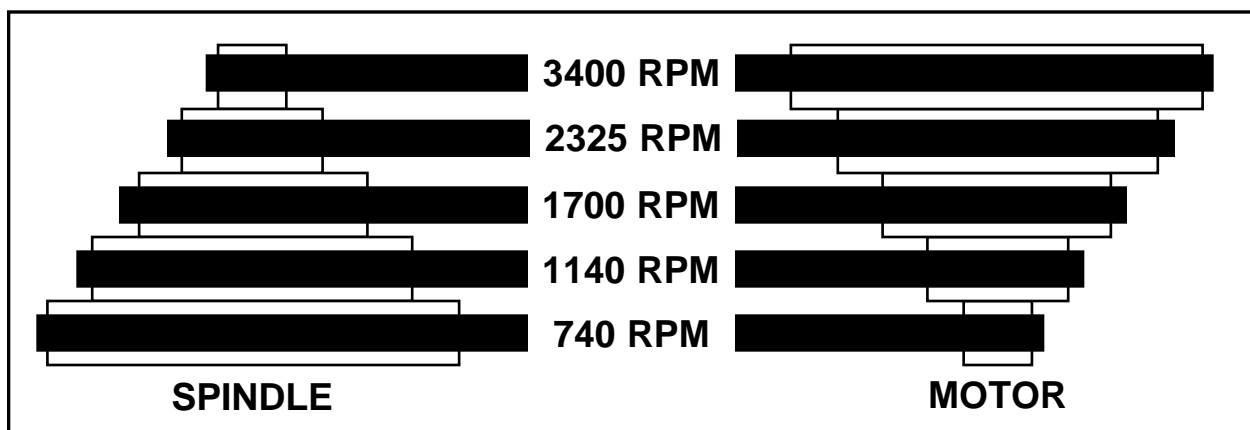

SECTION 4 — MACHINE DATA

GRIZZLY MODEL G1131 RADIAL DRILL PRESS

Design TypeBench Model

Overall Dimensions:

Table Size8⁵/₈"W x 9¹/₈"
Overall Height31¹/₂"
Overall Width12"
Overall Depth.....34"
Weight (Net)84 lbs.

Construction:

TableCast Iron
ColumnSteel Tube
Base and HeadCast Iron

Motor:

TypeTEFC Capacitor Start
Horsepower¹/₃ HP
Phase/CycleSingle Phase/60Hz
Voltage110V
Amps6
RPM1720
BearingsSealed & Lubricated For Life

Capacities:

Spindle Travel2⁷/₈"
Max. Spindle-to-base15¹/₂"
Max. Spindle-to-table10¹/₂"
Spindle TaperJT 33
Swing7¹/₂"
Chuck Size¹/₂"
Speeds740, 1140, 1700, 2325, 3400
Quill Diameter35mm

Features:

Table Tilt0°-45° Left and Right
Table Swing.....360°
DriveFive Step Pulley
Table LocksPositive
Table Height AdjustmentWorm Gear
Max. Spindle-to-base15¹/₂"
Head Tilt.....0°-90° Right, 0°-45° Left

Specifications, while deemed accurate, are not guaranteed.

SECTION 5 — PARTS LIST & DIAGRAM

Diag#	Part #	Description
1	PG1131001	BASE
2	PG1131002	FLANGE
3	PB07	HEX BOLT $\frac{5}{16}$ -18X $\frac{3}{4}$
4	PG1131004	RACK
5	PG1131005	VERT. COLUMN
6	PG1131006	CRANK
7	PG1131007	TABLE BRACKET
8	PW01	FLAT WASHER $\frac{1}{2}$ "
9	PB53	HEX BOLT $\frac{1}{2}$ -12X1
10	PG1131010	TABLE
11	PG1131011	CLAMP BOLT
12	PG1131012	LCK HNDLE ASSY
13	PG1131013	COLUMN BRACKET
14	PSS02	STSCRW $\frac{5}{16}$ -18X $\frac{3}{8}$
15	PG1131015	LOCK KNOB
16	PG1131016	MOUNT PLATE
17	PG1131017	SPRING
18	PG1131018	ADJ. BOLT
19	PG1131019	MOTOR
20	PG1131020	PULLEY COVER
21	PG1131021	MOTOR PULLEY
22	PG1131131	V-BELT
23	PG1131023	KNOB
24	PS04	PH. SCRW $\frac{1}{4}$ -20X $\frac{1}{2}$
25	PG1131025	SPINDLE PULLEY
26	PG1131026	DRIVE SLEEVE
27	PG1131027	40MM RET. RING
28	PB203	6203-2RS BEARING
29	PG1131029	KNOB
30	PLW01	$\frac{5}{16}$ " LOCK WSHR
31	PLN08	$\frac{1}{2}$ -20 LOCK NUT
32	PG1131032	COVER W/SPRING
33	PG1131033	HORIZ. COLUMN
34	PG1131034	HEADSTOCK
35	PSW07	SWITCH
36	PSS02	STSCRW $\frac{5}{16}$ -18X $\frac{3}{8}$
37	PS22	PH. SCRW 10-24X $\frac{5}{8}$
38	PG1131038	SW. MOUNT CVR

Diag#	Part #	Description
39	PG1131039	RUBBER WASHER
40	PG1131040	QUILL
41	PB202	6202-2RS BEARING
42	PG1131042	SPINDLE
43	PG1131043	CHUCK KEY
44	PG1131044	$\frac{1}{2}$ " CHUCK
45	PG1131045	SCALE SLEEVE
46	PG1131046	PINION
47	PG1131047	HUB
48	PG1131048	HANDLE
49	PG1131049	DEGREE SCALE
50	PG1131050	12MM RET. RING
51	PB201	6201-2RS BEARING
52	PG1131052	POWER CORD
53	PSS03	STSCRW $\frac{1}{4}$ -20X $\frac{3}{8}$
54	PS07	PH. SCRW $\frac{1}{4}$ -20X $\frac{3}{8}$
55	PG1131055	DOWN FD SCALE
56	PG1183108	RIVET
57	PG1131057	POINTER
58	PG1131058	LOCK KNOB
59	PG1131059	SPEC SETSCRW
60	PN02	HEX NUT $\frac{5}{16}$ -18
61	PG1131061	HANDLE
62	PG1131062	LABEL
63	PG1131063	WIRE STRAP
64	PS06	PH. SCRW 10-24X $\frac{3}{8}$
65	PG1131065	MTR/SWITCH CORD
66	PG1131066	SPEED CHART
67	PG1131067	SPEC. BOLT
68	PW07	FLAT WASHER $\frac{5}{16}$ "
69	PG1131069	TABLE SCALE
70	PG1131070	PIN
71	PG1131071	WORM SHAFT
72	PG1131072	HANDLE
73	PSS01M	STSCRW M6-1.0X10
74	PG1131074	10T GEAR
75	PG1131075	SAFETY LABEL
76	PG1131076	LOCKING GIB

G1131 RADIAL DRILL PRESS

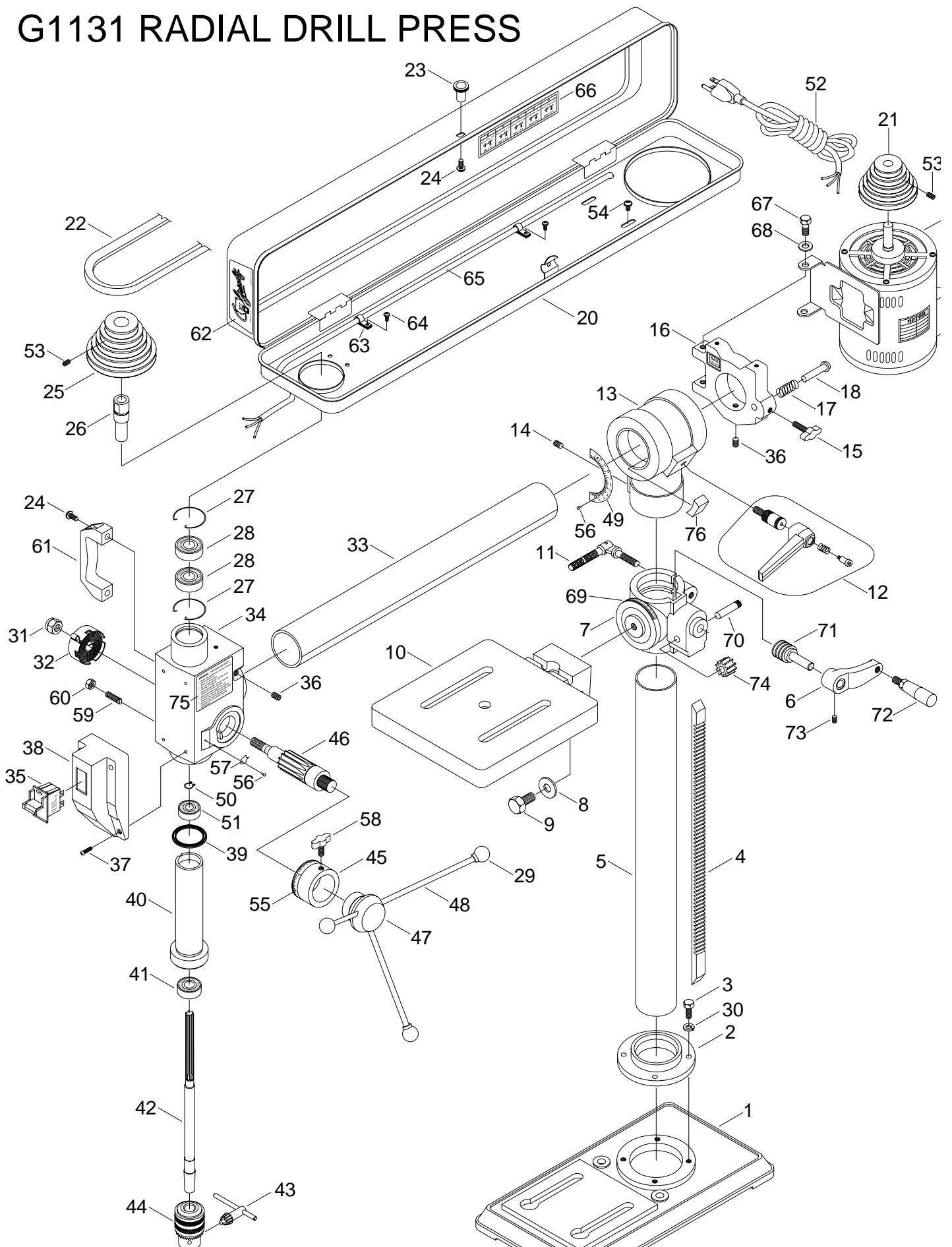

SECTION 6 — WARRANTY INFORMATION

Grizzly Imports, Inc. warrants every product it sells for a period of **1 year** to the original purchaser from the date of purchase. This warranty does not apply to defects due directly or indirectly to misuse, abuse, negligence, accidents, repairs or alterations or lack of maintenance. This is Grizzly's sole written warranty and any and all warranties that may be implied by law, including any merchantability or fitness, for any particular purpose, are hereby limited to the duration of this written warranty. We do not warrant or represent that the merchandise complies with the provisions of any law or acts unless the manufacturer so warrants. In no event shall Grizzly's liability under this warranty exceed the purchase price paid for the product and any legal actions brought against Grizzly shall be tried in the State of Washington, County of Whatcom.

We shall in no event be liable for death, injuries to persons or property or for incidental, contingent, special, or consequential damages arising from the use of our products.

To take advantage of this warranty, contact us by mail or phone and give us all the details. We will then issue you a "Return Number" which must be clearly posted on the outside as well as the inside of the carton. We will not accept any item back without this number. Proof of purchase must accompany the merchandise.

The manufacturers reserve the right to change specifications at any time because they constantly strive to achieve better quality equipment. We make every effort to ensure that our products meet high quality and durability standards and we hope you never need to use this warranty.

Please feel free to write or call us if you have any questions about the machine or the manual.

Thank you again for your business and continued support. We hope to serve you again soon.

Free Manuals Download Website

<http://myh66.com>

<http://usermanuals.us>

<http://www.somanuals.com>

<http://www.4manuals.cc>

<http://www.manual-lib.com>

<http://www.404manual.com>

<http://www.luxmanual.com>

<http://aubethermostatmanual.com>

Golf course search by state

<http://golfingnear.com>

Email search by domain

<http://emailbydomain.com>

Auto manuals search

<http://auto.somanuals.com>

TV manuals search

<http://tv.somanuals.com>