



**MODEL G0513X2BF
17" HEAVY-DUTY
BANDSAW w/MOTOR
BRAKE & FOOT BRAKE
MANUAL INSERT**

The Model G0513X2BF is the same machine as the Model G0513X except for electrical controls, the cast-iron trunnion assembly, and the foot brake.

Besides the data sheet, circuit requirements, power connection instructions, test run procedure, wiring diagrams, and parts, all other content in the Model G0513X owner's manual applies to this machine. Before operating your new machine, you **MUST** read and understand this insert and the entire Model G0513X manual to reduce the risk of injury when using this machine.

If you have any further questions about this manual insert or the differences between the Model G0513X2BF and the Model G0513X, contact our Technical Support at (570) 546-9663 or email techsupport@grizzly.com.



COPYRIGHT © MAY, 2011 BY GRIZZLY INDUSTRIAL, INC.
**WARNING: NO PORTION OF THIS MANUAL MAY BE REPRODUCED IN ANY SHAPE
OR FORM WITHOUT THE WRITTEN APPROVAL OF GRIZZLY INDUSTRIAL, INC.**
(FOR MODELS MANUFACTURED SINCE 3/11) #TS13953 PRINTED IN TAIWAN



MACHINE DATA SHEET

Customer Service #: (570) 546-9663 • To Order Call: (800) 523-4777 • Fax #: (800) 438-5901

MODEL G0513X2BF 17" BANDSAW w/MOTOR BRAKE AND FOOT PEDAL

Product Dimensions:

Weight 357 lbs.
Length/Width/Height 32" x 32" x 73"
Foot Print (Length/Width)..... 27" x 17¾"

Shipping Dimensions:

Type Wood Slat Crate
Content..... Machine
Weight..... 428 lbs.
Length/Width/Height..... 31" x 20" x 81"

Electrical:

Power Requirement 220V, Single-Phase, 60 Hz
Full-Load Current Rating..... 10A
Minimum Circuit Size 15 Amps
Switch..... Magnetic with Thermal Overload Protection
Switch Voltage 220V
Plug Included No
Recommended Plug/Outlet Type..... 6-15

Motor:

Main

Type..... TEFC Capacitor Start Induction
Horsepower 2 HP
Voltage 220V
Phase Single
Amps 10A
Speed 1725 RPM
Cycle..... 60 Hz
Number Of Speeds..... 1
Power Transfer..... Belt Drive
Bearings Shielded and Permanently Lubricated
Brake Built-In Magnetic Type 90VDC

Main Specifications:

Operation Information

Blade Speed..... 1700, 3500 FPM
Table Tilt..... Left 5°, Right 45°

Cutting Capacities

Maximum Cutting Height..... 12"
Throat Capacity Left of Blade..... 16¼"



Blade Information

Standard Blade Length.....	131½"
Blade Width Range	1/8"-1"
Upper Blade Guides.....	Ball Bearing
Lower Blade Guides.....	Ball Bearing

Table Information

Table Length	23⅝"
Table Width	17¼"
Table Thickness	1½"
Floor to Table Height.....	37½"

Fence Information

Locks in Front.....	Yes
Locks in Rear	No
Adjustable for Blade Lead	Yes

Construction

Table Construction	Precision Ground Cast Iron
Rip Fence	Cast Iron
Body Construction	One-Piece Reinforced Steel
Upper Wheel	Computer Balanced Cast Iron
Lower Wheel	Computer Balanced Cast Iron
Tire Material	Polyurethane
Wheel Cover.....	Pre-Formed Steel
Paint	Powder Coated

Other Related Information

Wheel Diameter.....	16¾"
Wheel Width	1¼" in.
Number of Dust Ports.....	2
Dust Port Size	4"
Mobile Base.....	G7314Z

Other Specifications:

ISO Factory.....	ISO 9001
Country Of Origin.....	Taiwan
Warranty.....	1 Year
Serial Number Location	ID Label on Upper Wheel Cover
Assembly & Setup Time	1 Hour

Features:

- Cast iron table trunnion
- Ball bearing blade guides
- Quick change blade release/tensioner
- Micro-adjusting gear table tilt
- Rack & pinion upper blade guide height adjustment
- Computer balanced cast iron wheels with grizzly bear head cut-outs
- Blade tension indicator
- Height scale for upper blade guides
- Blade tracking window
- Hinged wheel covers
- Deluxe cast iron fence with extruded aluminum resaw fence attachment
- Included miter gauge
- Included 1/2" blade
- Two 4" dust ports
- Motor stops in under 3 seconds after switch turned off
- Foot brake stop



SECTION 2: POWER SUPPLY

Availability

Before installing the machine, consider the availability and proximity of the required power supply circuit. If an existing circuit does not meet the requirements for this machine, a new circuit must be installed. To minimize the risk of electrocution, fire, or equipment damage, installation work and electrical wiring must be done by a qualified electrician in accordance with all applicable codes and standards.

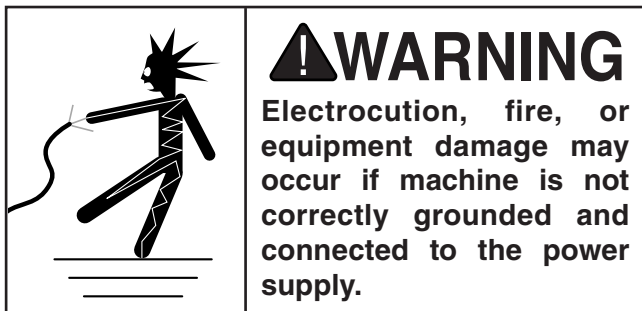

Full-Load Current Rating

The full-load current rating is the amperage a machine draws at 100% of the rated output power. On machines with multiple motors, this is the amperage drawn by the largest motor or sum of all motors and electrical devices that might operate at one time during normal operations.

Full-Load Current Rating at 220V 10 Amps

The full-load current is not the maximum amount of amps that the machine will draw. If the machine is overloaded, it will draw additional amps beyond the full-load rating.

If the machine is overloaded for a sufficient length of time, damage, overheating, or fire may result—especially if connected to an undersized circuit. To reduce the risk of these hazards, avoid overloading the machine during operation and make sure it is connected to a power supply circuit that meets the requirements in the following section.

Circuit Requirements for 220V

This machine is prewired to operate on a 220V power supply circuit that has a verified ground and meets the following requirements:

Nominal Voltage 220V/240V
Cycle.....60 Hz
Phase..... 1-Phase
Circuit Rating..... 15 Amps
Plug/Receptacle NEMA 6-15
Cord.....3-Wire, 14 AWG, 300VAC, “S”-Type

A power supply circuit includes all electrical equipment between the breaker box or fuse panel in the building and the machine. The power supply circuit used for this machine must be sized to safely handle the full-load current drawn from the machine for an extended period of time. (If this machine is connected to a circuit protected by fuses, use a time delay fuse marked D.)



Note: *The circuit requirements listed in this manual apply to a dedicated circuit—where only one machine will be running at a time. If this machine will be connected to a shared circuit where multiple machines will be running at the same time, consult a qualified electrician to ensure that the circuit is properly sized for safe operation.*



Grounding Instructions

This machine **MUST** be grounded. In the event of certain malfunctions or breakdowns, grounding reduces the risk of electric shock by providing a path of least resistance for electric current.

The power cord and plug specified under “Circuit Requirements for 220V” on the previous page has an equipment-grounding wire and a grounding prong. The plug must only be inserted into a matching receptacle (outlet) that is properly installed and grounded in accordance with all local codes and ordinances (see figure below).

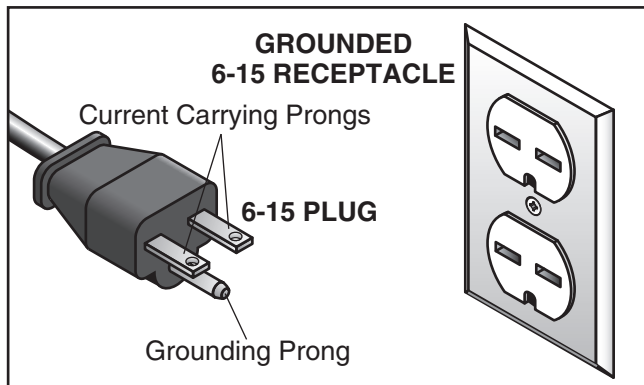
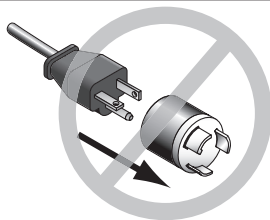

Figure 1. Typical 6-15 plug and receptacle.

⚠ CAUTION



No adapter should be used with the provided plug. If the plug does not fit the available receptacle, or the machine must be reconnected for use on a different type of circuit, the reconnection must be made by a qualified electrician and comply with all local codes and ordinances.

⚠ WARNING

Serious injury could occur if you connect the machine to power before completing the setup process. DO NOT connect to power until instructed later in this manual.

Improper connection of the equipment-grounding wire can result in a risk of electric shock. The wire with green insulation (with or without yellow stripes) is the equipment-grounding wire. If repair or replacement of the power cord or plug is necessary, do not connect the equipment-grounding wire to a live (current carrying) terminal.

Check with a qualified electrician or service personnel if you do not understand these grounding requirements, or if you are in doubt about whether the tool is properly grounded. If you ever notice that a cord or plug is damaged or worn, disconnect it from power, and immediately replace it with a new one.

Extension Cords

We do not recommend using an extension cord with this machine. If you must use an extension cord, only use it if absolutely necessary and only on a temporary basis.

Extension cords cause voltage drop, which may damage electrical components and shorten motor life. Voltage drop increases as the extension cord size gets longer and the gauge size gets smaller (higher gauge numbers indicate smaller sizes).

Any extension cord used with this machine must contain a ground wire, match the required plug and receptacle, and meet the following requirements:

Minimum Gauge Size 14 AWG
Maximum Length (Shorter is Better).....50 ft.



Power Connection

After you have completed all previous setup instructions and circuit requirements, the machine is ready to be connected to the power supply.

To avoid unexpected startups or property damage, use the following steps whenever connecting or disconnecting the machine.

Connecting Power

1. Turn the machine power switch **OFF**.
2. Insert the power cord plug into a matching power supply receptacle. The machine is now connected to the power source.

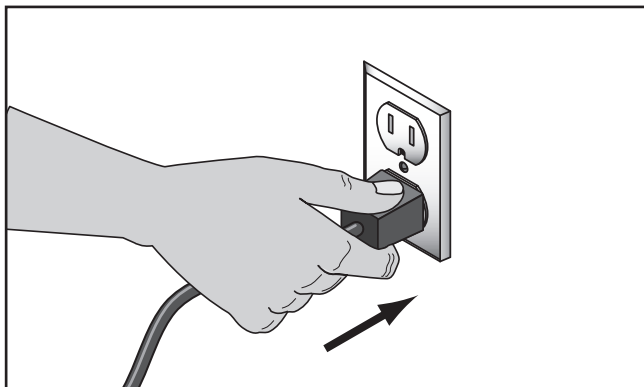

Figure 2. Connecting power.

Disconnecting Power

1. Turn the machine power switch **OFF**.
2. Grasp the molded plug and pull it completely out of the receptacle. Do not pull by the cord as this may damage the wires inside.

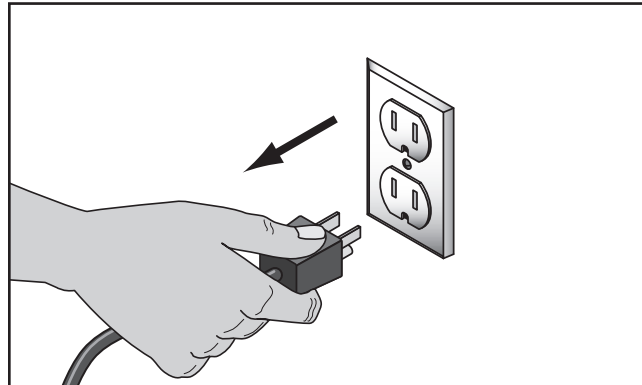

Figure 3. Disconnecting power.

Test Run

To test run the machine:

1. Follow **Steps 1-5** on **Page 26** of the G0513X Owner's Manual.
2. Verify that the machine is operating correctly by inserting the key into the power switch and turning it to "1". Now start the bandsaw by pressing the ON button. (see **Figure 4**)

—When operating correctly, the machine runs smoothly with little or no vibration or rubbing noises.

—Investigate and correct strange or unusual noises or vibrations before operating the machine further. Always disconnect the machine from power when investigating or correcting potential problems.

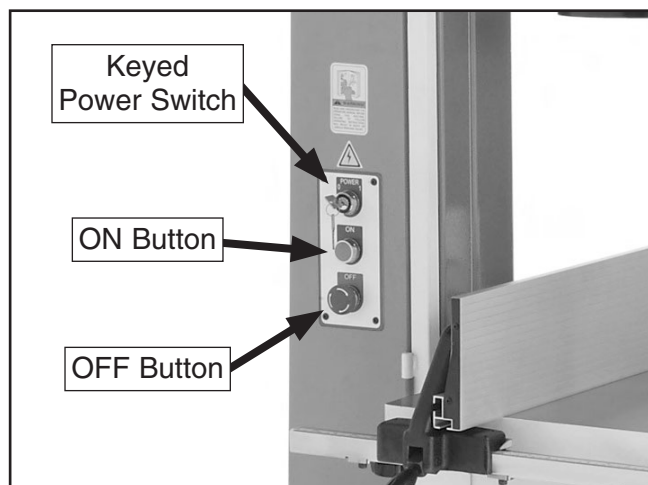

Figure 4. Control panel.

3. Press the OFF button to stop the machine.

4. WITHOUT resetting the OFF button, press the ON button. The machine should not start.

—If the machine does not start, the OFF button safety feature is working correctly.

—If the machine does start (with the stop button pushed in), immediately disconnect power to the machine. The OFF button safety feature is not working correctly. This safety feature must work properly before proceeding with regular operations. Call Tech Support for help.

5. Push the OFF button in, then twist it clockwise so it pops out. When the OFF button pops out, the switch is reset and ready for operation (see **Figure 5**).

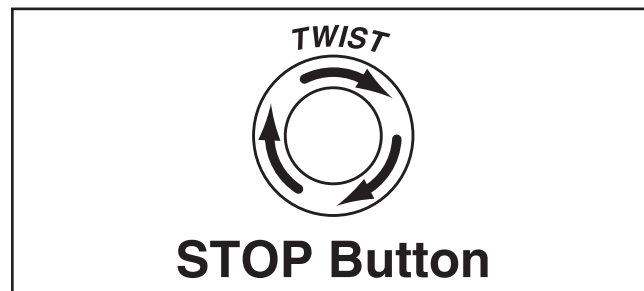

Figure 5. Resetting the switch.

6. Turn the switch disabling key to "0", as shown in **Figure 4**.

7. Try to turn the machine **ON**.

—If the bandsaw does not start, the switch disabling feature is working as designed. The Test Run is complete.

—If the bandsaw starts, immediately disconnect power. The switch disabling feature is not working correctly. This safety feature must work properly before proceeding with regular operations. Call Tech Support for help.



Lubrication

To lubricate the blade guide rack and pinion:

1. DISCONNECT BANDSAW FROM POWER!
2. Lower the blade guide until it reaches the table.
3. Wipe off any existing grease and sawdust buildup on the guide post rack (see **Figure 6**).

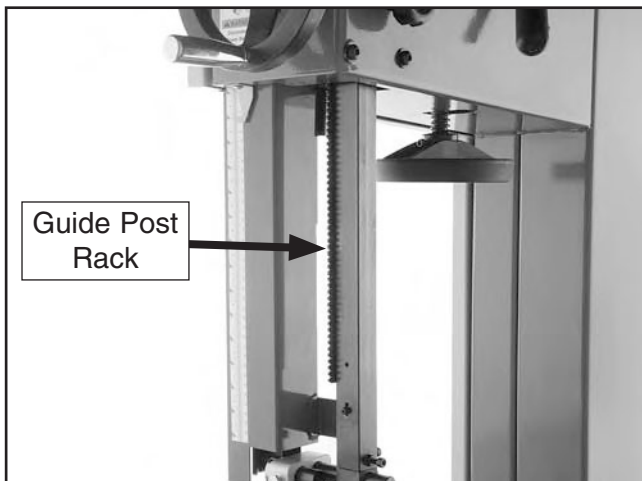

Figure 6. Guide post rack lubrication location.

4. Apply a thin coat of light all-purpose grease to the rack.
5. Move the blade guide up and down several times to distribute the grease, then remove any excess to help prevent sawdust buildup.

To lubricate the blade tracking knob:

1. DISCONNECT BANDSAW FROM POWER!
2. Unscrew the blade tracking knob 5 turns.
3. Wipe off any existing grease and sawdust buildup on the threads.
4. Apply a few dabs of a light all-purpose grease to the threads.
5. Re-adjust tracking (see **Blade Tracking** on **Page 22** of the G0513X Owner's Manual for detailed instructions).

To lubricate the tension adjustment assembly:

1. DISCONNECT BANDSAW FROM POWER!
2. Open the top wheel cover and look through the top of the wheel.
3. Wipe off any existing grease and sawdust buildup on the blade tension adjustment assembly and tension lever cam.
4. Apply a thin coat of grease to the tension adjustment assembly and tension lever cam (see **Figure 7**).



Figure 7. Tension adjustment assembly locations (top wheel removed for clarity).

To lubricate the trunnions:

1. DISCONNECT BANDSAW FROM POWER!
2. Move the table up until it reaches its maximum 45° angle and wipe off all excess grease and sawdust from the trunnions.
3. Apply a thin coat of light all purpose grease to the trunnions (see **Figure 8**).



Figure 8. Trunnion lubrication location.

4. Move the table down and then back up to distribute the grease, then wipe off any excess to help prevent sawdust buildup.

Magnetic Brake Adjustment

Magnetic Brake Adjustment

The space between the magnetic motor brake and brake shoe is preset by the factory at 0.008" (0.2mm). However, you should adjust this space every two to three years, or if the brake takes over five seconds for to stop the motor.

Tools Needed

Phillips Head Screwdriver	1
Feeler Gauge 0.008"	2
Hex Wrench 3mm.....	1
Hex Wrench 4mm.....	1

To adjust the space between the magnetic brake and brake shoe:

1. DISCONNECT BANDSAW FROM POWER!
2. Remove the motor fan cover, then loosen the cap screws securing the motor fan and brake shoe (see **Figure 9**).

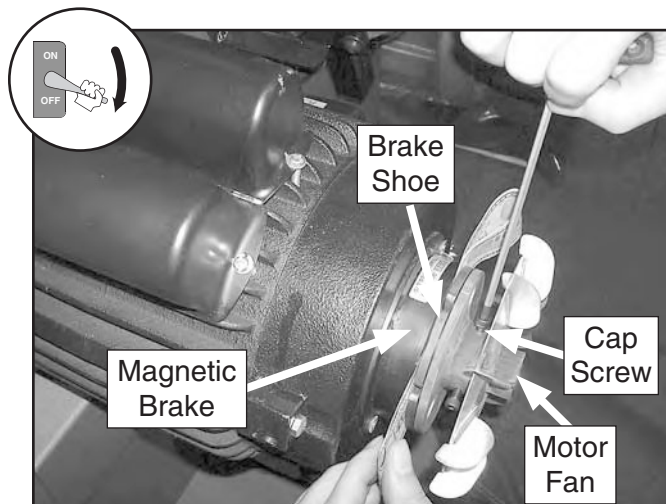

Figure 9. Adjusting distance between magnetic brake and brake shoe.

3. Place the feeler gauge between the brake shoe and magnetic brake on either side.
4. Tighten the cap screws on the brake shoe and motor fan, remove the feeler gauge, then reinstall the motor fan cover.



SECTION 8: WIRING

These pages are current at the time of printing. However, in the spirit of improvement, we may make changes to the electrical systems of future machines. Compare the manufacture date of your machine to the one stated in this manual, and study this section carefully.

If there are differences between your machine and what is shown in this section, call Technical Support at (570) 546-9663 for assistance BEFORE making any changes to the wiring on your machine. An updated wiring diagram may be available. **Note:** Please gather the serial number and manufacture date of your machine before calling. This information can be found on the main machine label.

WARNING

Wiring Safety Instructions

SHOCK HAZARD. Working on wiring that is connected to a power source is extremely dangerous. Touching electrified parts will result in personal injury including but not limited to severe burns, electrocution, or death. Disconnect the power from the machine before servicing electrical components!

MODIFICATIONS. Modifying the wiring beyond what is shown in the diagram may lead to unpredictable results, including serious injury or fire. This includes the installation of unapproved after-market parts.

WIRE CONNECTIONS. All connections must be tight to prevent wires from loosening during machine operation. Double-check all wires disconnected or connected during any wiring task to ensure tight connections.

CIRCUIT REQUIREMENTS. You MUST follow the requirements at the beginning of this manual when connecting your machine to a power source.

WIRE/COMPONENT DAMAGE. Damaged wires or components increase the risk of serious personal injury, fire, or machine damage. If you notice that any wires or components are damaged while performing a wiring task, replace those wires or components.

MOTOR WIRING. The motor wiring shown in these diagrams is current at the time of printing but may not match your machine. If you find this to be the case, use the wiring diagram inside the motor junction box.







CAPACITORS/INVERTERS. Some capacitors and power inverters store an electrical charge for up to 10 minutes after being disconnected from the power source. To reduce the risk of being shocked, wait at least this long before working on capacitors.

EXPERIENCING DIFFICULTIES. If you are experiencing difficulties understanding the information included in this section, contact our Technical Support at (570) 546-9663.

NOTICE

The photos and diagrams included in this section are best viewed in color. You can view these pages in color at www.grizzly.com.

COLOR KEY

BLACK		BLUE		YELLOW		LIGHT BLUE	
WHITE		BROWN		YELLOW GREEN		BLUE WHITE	
GREEN		GRAY		PURPLE		TURQUOISE	
RED		ORANGE		PINK			



220V Wiring Diagram

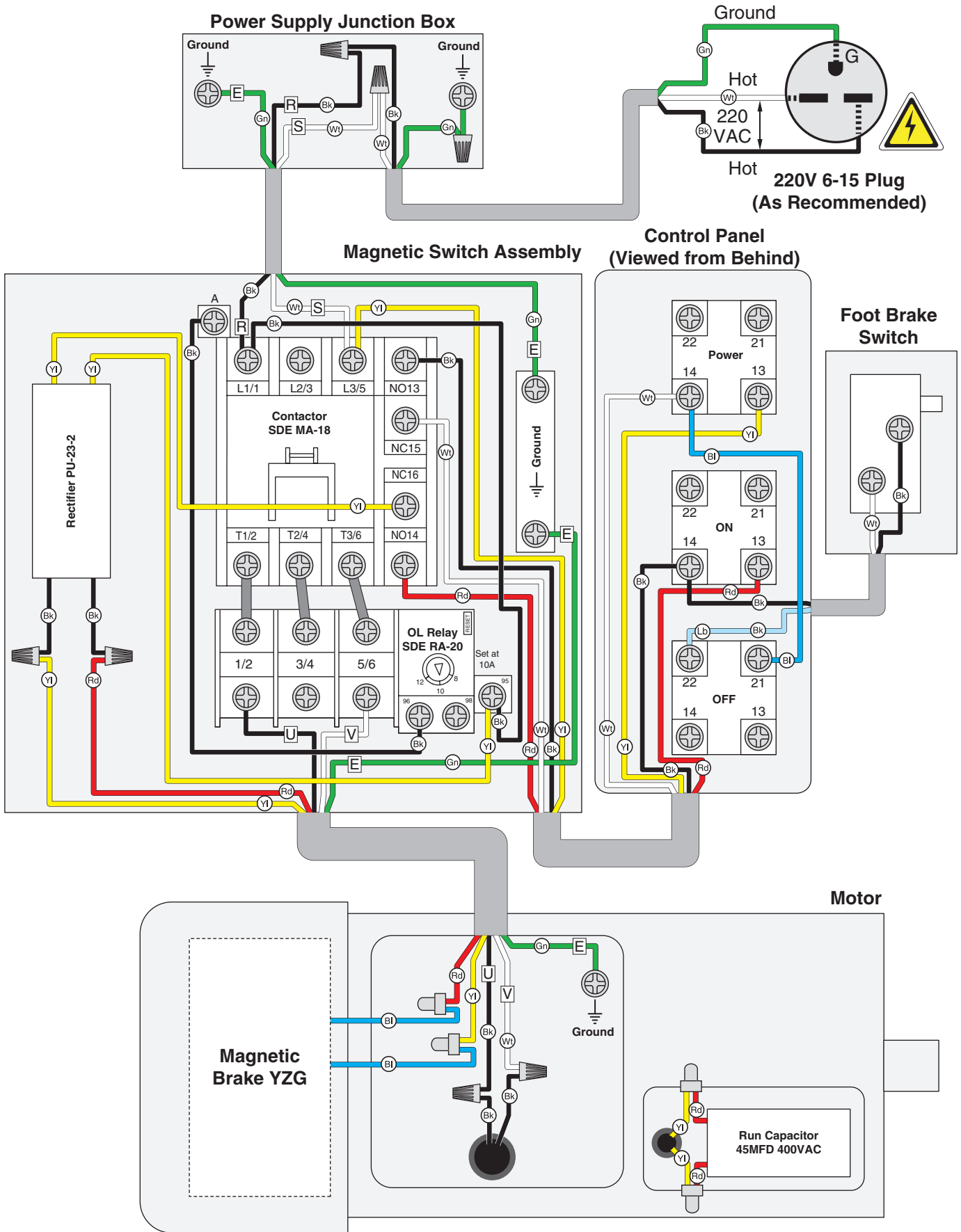

Main Parts Breakdown

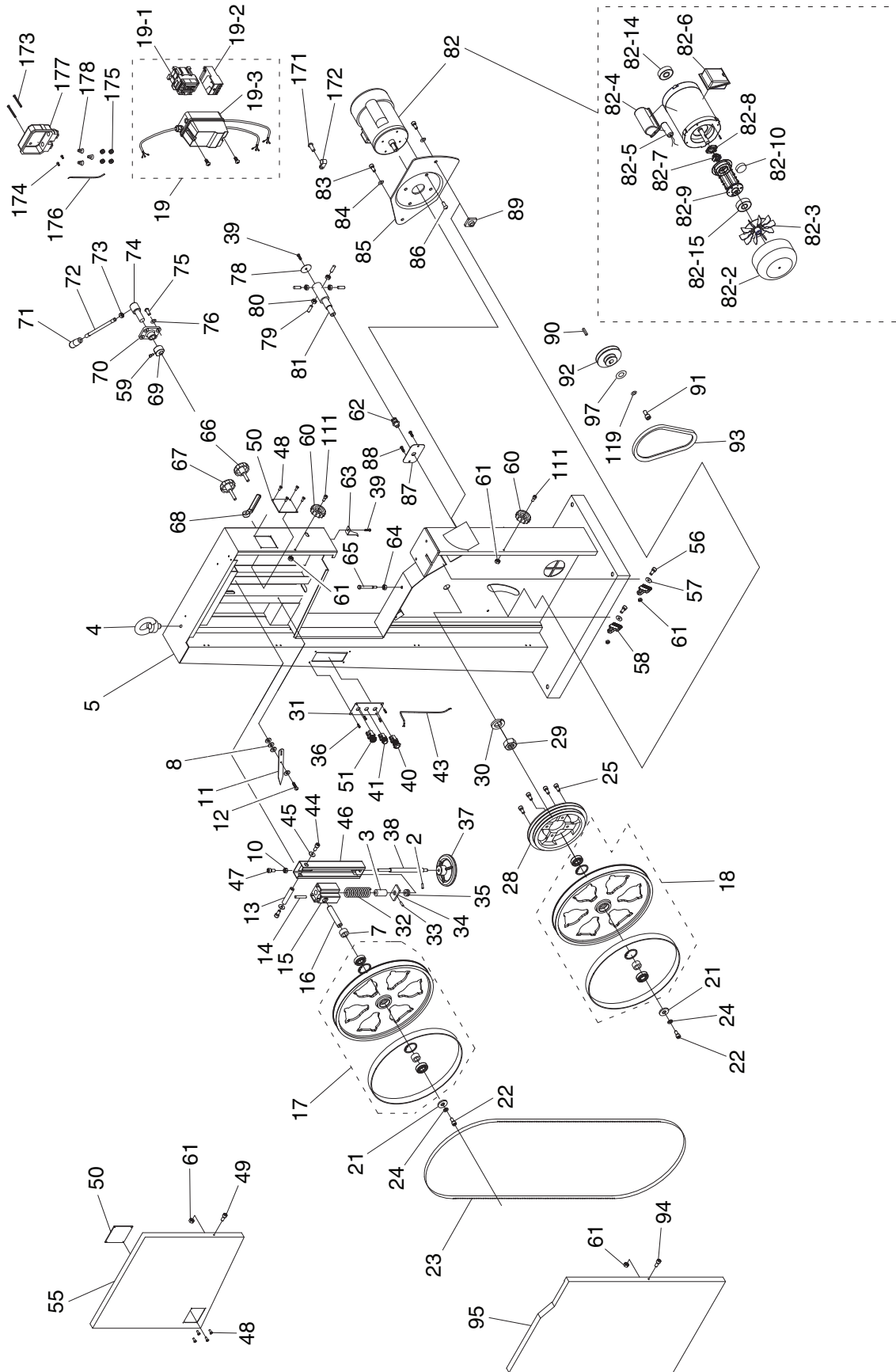

Main Parts List

REF	PART #	DESCRIPTION
2	PSS01M	SET SCREW M6-1 X 10
3	P0513X003	SPACER
4	P0513004	LIFTING RING M10-1.5
5	P0513X2F005	MACHINE BODY
7	P0513X007	BUSHING
8	PW03M	FLAT WASHER 6MM
10	PN01M	HEX NUT M6-1
11	P0513011	POINTER
12	P0513012	STEP SCREW M4-.7 X 5
13	P0513013	SLEEVE
14	PRP91M	ROLL PIN 5 X 35
15	P0513015	UPPER WHEEL SHAFT BRACKET
16	P0513016	UPPER WHEEL SHAFT
17	P0513X2B017	UPPER WHEEL ASSEMBLY
18	P0513X2B018	LOWER WHEEL ASSEMBLY
19	P0513X2BF019	MAG SWITCH ASSY SDE MA-09
19-1	P0513X2BF019-1	CONTACTOR SDE MA-18 220V
19-2	P0513X2BF019-2	OL RELAY SDE RA-20 8-12A
19-3	P0513X2BF019-3	SWITCH BOX
21	PW01M	FLAT WASHER 8MM
22	PCAP11M	CAP SCREW M8-1.25 X 16
23	P0513023	BLADE 131.7" X 1/2" 6TPI SKIP
24	PLW04M	LOCK WASHER 8MM
25	PCAP14M	CAP SCREW M8-1.25 X 20
28	P0513X2F028	IDLER PULLEY/BRAKE DRUM
29	PN32	HEX NUT 1-14
30	PLW09	LOCK WASHER 1"
31	P0513X2B031	CONTROL PANEL
32	P0513032	SPRING 7 X 8 X 90
33	PRP02M	ROLL PIN 3 X 16
34	P0513034	SHAFT BRACKET BASE
35	P51201	THRUST BEARING 51201
36	PHTEK15M	TAP SCREW M4 X 10
37	P0513037	TENSION HANDWHEEL
38	P0513038	TENSION ADJUSTMENT ROD
39	PFS07M	FLANGE SCREW M5-.8 X 10
40	P0513X2B040	OFF BUTTON
41	P0513X2B041	ON BUTTON
43	P0513X2B043	SWITCH CORD
44	PCAP11M	CAP SCREW M8-1.25 X 16
45	PWF08M	FENDER WASHER 8MM
46	P0513046	UPPER WHEEL SLIDE BRACKET
47	PCAP06M	CAP SCREW M6-1 X 25
48	PRIV005M	STEEL BLIND RIVET 3 X 13MM
49	PCAP04M	CAP SCREW M6-1 X 10
50	P0513050	CLEAR WINDOW
51	P0513X2B051	KEYED POWER SWITCH
55	P0513055	UPPER WHEEL COVER
56	PB10M	HEX BOLT M6-1 X 25
57	PW03M	FLAT WASHER 6MM
58	P0513058	WHEEL BRUSH
59	PCAP06M	CAP SCREW M6-1 X 25
60	P0513X060	STAR HANDLE
61	PLN03M	LOCK NUT M6-1
62	P0513062	BUSHING 16MM

REF	PART #	DESCRIPTION
63	P0513063	HEIGHT POINTER
64	PN03M	HEX NUT M8-1.25
65	PB124M	HEX BOLT M8-1.25 X 90
66	P0513066	KNOB BOLT M10-1.5 X 20
67	P0513067	KNOB BOLT M10-1.5 X 53
68	P0513068	THREADED HANDLE 10MM
69	P0513069	CAM
70	P0513070	PILLOW BLOCK
71	P0513071	KNOB
72	P0513072	TENSION LEVER
73	PN09M	HEX NUT M12-1.75
74	P0513074	SHAFT
75	PBHS22M	BUTTON HD CAP SCR M8-1.25 X 20
76	PLW04M	LOCK WASHER 8MM
78	P0513078	SHAFT END CAP
79	PSS09M	SET SCREW M8-1.25 X 20
80	PN03M	HEX NUT M8-1.25
81	P0513X2F081	LOWER WHEEL SHAFT
82	P0513X2BF082	MOTOR 2HP 220V 1PH W/BRAKE
82-2	P0513X2BF082-2	MOTOR FAN COVER
82-3	P0513X2BF082-3	MOTOR FAN
82-4	P0513X2BF082-4	CAPACITOR COVER
82-5	PC045B	R CAPACITOR 45M 400V 2 x 2-1/2
82-6	P0513X2BF082-6	JUNCTION BOX
82-7	P0513X2BF082-7	CENTRIFUGAL SWITCH
82-8	P0513X2BF082-8	CONTACT PLATE
82-9	P0513X2BF082-9	MAGNETIC BRAKE
82-10	P0513X2BF082-10	MOTOR BRAKE PAD
82-14	P6205ZZ	FRONT MOTOR BALL BEARING 6205ZZ
82-15	P6203ZZ	REAR MOTOR BALL BEARING 6203ZZ
83	PB32M	HEX BOLT M10-1.5 X 25
84	PLW06M	LOCK WASHER 10MM
85	P0513085	MOTOR BRACKET
86	PBHS22M	BUTTON HD CAP SCR M8-1.25 X 20
87	P0513X2F087	COVER
88	PHTEK15M	TAP SCREW M4 X 10
89	P0513089	PILLOW BLOCK
90	PK15M	KEY 5 X 5 X 35
91	PB81M	HEX BOLT M8-1.25 X 20 LH
92	P0513092	MOTOR PULLEY 3.5"
93	PVA42	V-BELT A42
94	PCAP04M	CAP SCREW M6-1 X 10
95	P0513095	LOWER WHEEL COVER
97	PWF08M	FENDER WASHER 8MM
111	PCAP02M	CAP SCREW M6-1 X 20
119	PLW04M	LOCK WASHER 8MM
171	PFS07M	FLANGE SCREW M5-.8 X 10
172	P0513X2F189	CORD CLIP 5/16"
173	PFS09M	FLANGE SCREW M5-.8 X 50
174	PS38M	PHLP HD SCR M4-.7 X 10
175	PTLW02M	EXT TOOTH WASHER 5MM
176	P0513X2F192	CONNECTING CORD
177	P0513X2F197	JUNCTION BOX
178	PWRN01	WIRE NUT



Sub-Assemblies

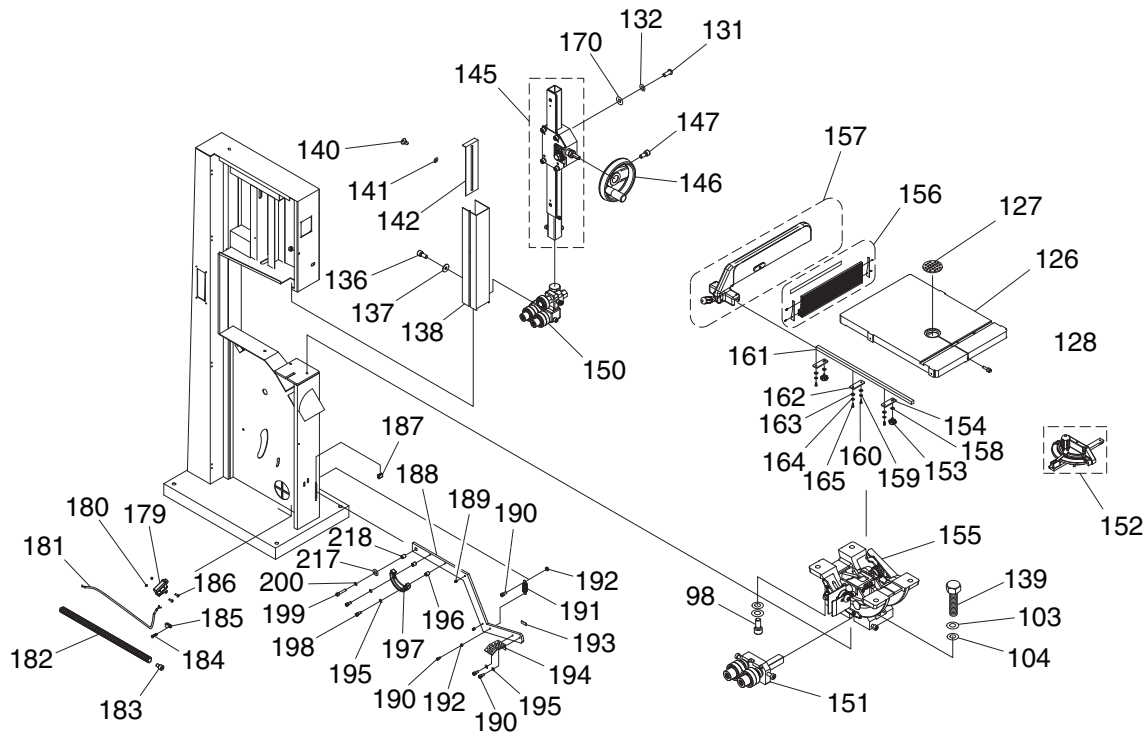

REF	PART #	DESCRIPTION
98	PCAP84M	CAP SCREW M10-1.5 X 35
103	PLW06M	LOCK WASHER 10MM
104	PW04M	FLAT WASHER 10MM
126	P0513X2B126	TABLE 17-1/4" X 23-5/8"
127	P0513X127	TABLE INSERT
128	P0513X128	TABLE PIN
131	PBHS22M	BUTTON HD CAP SCR M8-1.25 X 20
132	PLW04M	LOCK WASHER 8MM
136	PCAP50M	CAP SCREW M5-.8 X 10
137	PW02M	FLAT WASHER 5MM
138	P0513X138	BLADE GUARD
139	PB14M	HEX BOLT M10-1.5 X 35
140	P0513X140	SHOULDER SCREW
141	P0513X141	FIBER WASHER
142	P0513X142	SLIDING PLATE
145	P0513X2B145	GUIDE POST ASSEMBLY
146	P0513X146	GUIDE POST HANDWHEEL
147	PCAP02M	CAP SCREW M6-1 X 20
150	P0513X150	UPPER BLADE GUIDE ASSEMBLY
151	P0513X151	LOWER BLADE GUIDE ASSEMBLY
152	P0513X152	MITER GAUGE ASSEMBLY
153	P0513X2B153	KNOB SCREW M8-1.25 X 20
154	P0513X2B154	OUTER RAIL PLATE
155	P0513X2155	CAST IRON TRUNNION ASSEMBLY
156	P0513X2B156	RESAW FENCE ASSEMBLY
157	P0513X2B157	FENCE ASSEMBLY
158	PW01M	FLAT WASHER 8MM
159	PLW04M	LOCK WASHER 8MM
160	PCAP14M	CAP SCREW M8-1.25 X 20
161	P0513X2B161	FRONT RAIL
162	P0513X2B162	INNER RAIL PLATE
163	PW03M	FLAT WASHER 6MM
164	PLW03M	LOCK WASHER 6MM
165	PCAP02M	CAP SCREW M6-1 X 20
170	PW01M	FLAT WASHER 8MM
179	P0513X2F218	FOOT BRAKE SWITCH
180	PN28	HEX NUT 4MM
181	P0513X2F220	SWITCH CORD
182	P0513X2F221	FLEXIBLE CORD CONDUIT 1/2" X 43"
183	P0513X2F222	CONDUIT GROMMET
184	PHTEK4M	TAP SCREW M4 X 8
185	P0513X2F224	CORD CLIP 5/8"
186	PS51M	PHLP HD SCR M4-.7 X 30
187	P0513X2F226	RUBBER CLIP
188	P0513X2F227	FOOT BRAKE LEVER
189	P0513X2F228	STEP BOLT M7-1 X 10 W/BUSHING
190	PCAP01M	CAP SCREW M6-1 X 16
191	P0513X2F230	BRAKE EXTENSION SPRING
192	PN01M	HEX NUT M6-1
193	P0513X2F232	NYLON PAD
194	P0513X2F233	FOOT PAD
195	PLW03M	LOCK WASHER 6MM
196	P0513X2F235	BUSHING
197	P0513X2F236	BRAKE SHOE
198	PCAP06M	CAP SCREW M6-1 X 25
199	PCAP31M	CAP SCREW M8-1.25 X 25
200	PLW04M	LOCK WASHER 8MM
217	PW01M	FLAT WASHER 8MM
218	P0513X2F241	BUSHING

REF	PART #	DESCRIPTION
162	P0513X2B162	INNER RAIL PLATE
163	PW03M	FLAT WASHER 6MM
164	PLW03M	LOCK WASHER 6MM
165	PCAP02M	CAP SCREW M6-1 X 20
170	PW01M	FLAT WASHER 8MM
179	P0513X2F218	FOOT BRAKE SWITCH
180	PN28	HEX NUT 4MM
181	P0513X2F220	SWITCH CORD
182	P0513X2F221	FLEXIBLE CORD CONDUIT 1/2" X 43"
183	P0513X2F222	CONDUIT GROMMET
184	PHTEK4M	TAP SCREW M4 X 8
185	P0513X2F224	CORD CLIP 5/8"
186	PS51M	PHLP HD SCR M4-.7 X 30
187	P0513X2F226	RUBBER CLIP
188	P0513X2F227	FOOT BRAKE LEVER
189	P0513X2F228	STEP BOLT M7-1 X 10 W/BUSHING
190	PCAP01M	CAP SCREW M6-1 X 16
191	P0513X2F230	BRAKE EXTENSION SPRING
192	PN01M	HEX NUT M6-1
193	P0513X2F232	NYLON PAD
194	P0513X2F233	FOOT PAD
195	PLW03M	LOCK WASHER 6MM
196	P0513X2F235	BUSHING
197	P0513X2F236	BRAKE SHOE
198	PCAP06M	CAP SCREW M6-1 X 25
199	PCAP31M	CAP SCREW M8-1.25 X 25
200	PLW04M	LOCK WASHER 8MM
217	PW01M	FLAT WASHER 8MM
218	P0513X2F241	BUSHING



Machine Labels

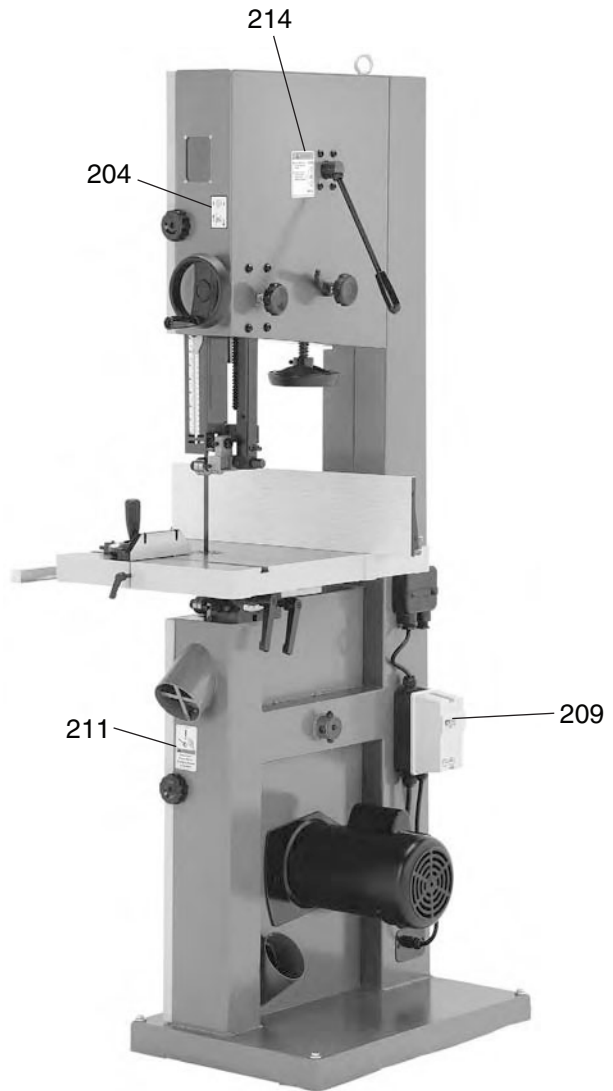
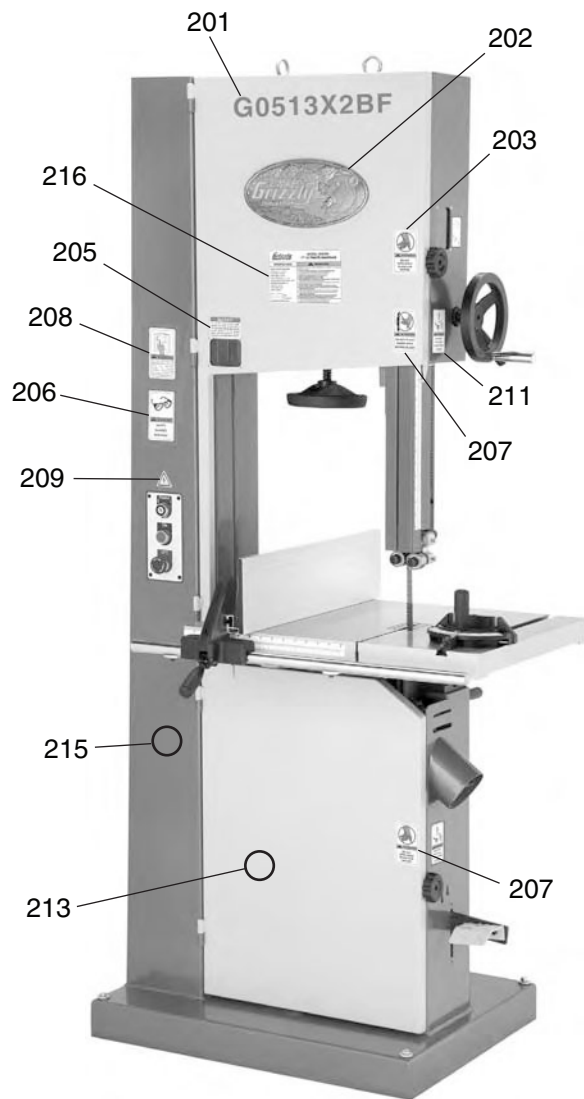

REF	PART #	DESCRIPTION
201	P0513X2BF201	MODEL NUMBER LABEL
202	G8589	NAMEPLATE-LARGE
203	PLABEL-20	DON'T OPEN DOOR LABEL
204	P0513X204	GUARD ADJUSTMENT LABEL
205	P0513X205	SCALE DIRECTIONS LABEL
206	PLABEL-11	SAFETY GLASSES LABEL
207	PLABEL-19	HANDS/BLADE HAZARD LABEL

REF	PART #	DESCRIPTION
208	PLABEL-12	READ MANUAL LABEL
209	PLABEL-14	ELECTRICITY LABEL
211	PLABEL-18	UNPLUG/DOOR HAZARD LABEL
213	PPAINT-11	PUTTY TOUCH-UP PAINT
214	P0513X214	TENSION ADJ LABEL
216	P0513X2BF219	MACHINE ID LABEL
215	PPAINT-1	GRIZZLY GREEN TOUCH-UP PAINT

WARNING

Safety labels warn about machine hazards and ways to prevent injury. The owner of this machine **MUST** maintain the original location and readability of the labels on the machine. If any label is removed or becomes unreadable, **REPLACE** that label before using the machine again. Contact Grizzly at (800) 523-4777 or www.grizzly.com to order new labels.



Accessories

⚠️ WARNING

Some aftermarket accessories can be installed on this machine that could cause it to function improperly, increasing the risk of serious personal injury. To minimize this risk, only install accessories recommended for this machine by Grizzly.

NOTICE

Refer to the newest copy of the Grizzly Catalog for other accessories available for this machine.

Call 1-800-523-4777 To Order

- T20501—Face Shield Crown Protector 4"
- T20502—Face Shield Crown Protector 7"
- T20503—Face Shield Window
- T20452—"Kirova" Anti-Reflective S. Glasses
- T20451—"Kirova" Clear Safety Glasses
- H0736—Shop Fox® Safety Glasses
- H7194—Bifocal Safety Glasses 1.5
- H7195—Bifocal Safety Glasses 2.0
- H7196—Bifocal Safety Glasses 2.5



Figure 10. Eye protection assortment.

- H2499—Small Half-Mask Respirator
- H3631—Medium Half-Mask Respirator
- H3632—Large Half-Mask Respirator
- H3635—Cartridge Filter Pair P100

Wood dust has been linked to nasal cancer and severe respiratory illnesses. If you work around dust everyday, a half-mask respirator can be a lifesaver. Also compatible with safety glasses!



Figure 11. Half-mask respirator with disposable cartridge filters.

131-1/2" Carbon Steel Bandsaw Blades for the G0513X2BF

Model	Width	TPI	Gauge
H4803	1/8"	14 Raker	0.025
H4804	1/4"	6 Hook	0.025
H4805	1/4"	18 Raker	0.025
H4806	3/8"	10 Raker	0.025
H4807	1/2"	6 Hook	0.025
H4808	1/2"	10 Raker	0.025
H4809	3/4"	3 Hook	0.032
H4810	1"	6 Hook	0.035
H4811	1"	2 Hook	0.035



Grizzly **Industrial, Inc.**®

MODEL G0513X/G0514X/G0514X3 EXTREME SERIES BANDSAW OWNER'S MANUAL



COPYRIGHT © JANUARY, 2006 BY GRIZZLY INDUSTRIAL, INC. REVISED FEBRUARY, 2007 (TR)

**WARNING: NO PORTION OF THIS MANUAL MAY BE REPRODUCED IN ANY SHAPE
OR FORM WITHOUT THE WRITTEN APPROVAL OF GRIZZLY INDUSTRIAL, INC.**

#EWTR7787 PRINTED IN TAIWAN



WARNING!

This manual provides critical safety instructions on the proper setup, operation, maintenance and service of this machine/equipment.

Failure to read, understand and follow the instructions given in this manual may result in serious personal injury, including amputation, electrocution or death.

The owner of this machine/equipment is solely responsible for its safe use. This responsibility includes but is not limited to proper installation in a safe environment, personnel training and usage authorization, proper inspection and maintenance, manual availability and comprehension, application of safety devices, blade/cutter integrity, and the usage of personal protective equipment.

The manufacturer will not be held liable for injury or property damage from negligence, improper training, machine modifications or misuse.



WARNING!

Some dust created by power sanding, sawing, grinding, drilling, and other construction activities contains chemicals known to the State of California to cause cancer, birth defects or other reproductive harm. Some examples of these chemicals are:

- **Lead from lead-based paints.**
- **Crystalline silica from bricks, cement and other masonry products.**
- **Arsenic and chromium from chemically-treated lumber.**

Your risk from these exposures varies, depending on how often you do this type of work. To reduce your exposure to these chemicals: Work in a well ventilated area, and work with approved safety equipment, such as those dust masks that are specially designed to filter out microscopic particles.

Table of Contents

INTRODUCTION	3
Foreword	3
Contact Info.....	3
G0513X Machine Data Sheet	4
G0514X Machine Data Sheet	6
G0514X3 Machine Data Sheet	8
Identification	10
SECTION 1: SAFETY	11
Safety Instructions for Machinery.....	11
Additional Safety Instructions for Bandsaws.....	13
SECTION 2: CIRCUIT REQUIREMENTS	14
Operation.....	14
Grounding.....	15
Extension Cords.....	15
Phase Converter	15
SECTION 3: SET UP	16
Set Up Safety	16
Items Needed for Set Up	16
Unpacking	16
Inventory.....	17
Hardware Recognition Chart.....	18
Clean Up	19
Site Considerations	19
Moving & Placing Base Unit.....	20
Mounting.....	20
Table	21
Blade Tracking	22
Positive Stop	23
Dust Collection	24
Installing Fence	25
Test Run.....	26
Tensioning Blade	27
Adjusting Support Bearings.....	27
Adjusting Blade Guide Bearings	29
Aligning Table	30
Aligning Fence	31
Miter Gauge	31
SECTION 4: OPERATIONS	32
Operation Safety	32
Overview	32
START/STOP Switch	33
Guide Post	33
Fine Tune Tracking	34
Blade Lead	34
Table Tilt	35
Ripping	36
Crosscutting	36
Resawing.....	37
Cutting Curves	38
Stacked Cuts.....	38
Blade Speed.....	39
Blade Information	40
Blade Changes.....	42

SECTION 5: ACCESSORIES	43
SECTION 6: MAINTENANCE	45
Schedule	45
Cleaning	45
Unpainted Cast Iron	45
Lubrication.....	45
Wheel Brush.....	45
SECTION 7: SERVICE	46
Troubleshooting.....	46
Checking V-Belt	48
Tensioning V-Belt.....	48
Replacing V-Belt	49
Adjusting Tension Lever.....	50
Adjusting Wheel Brush.....	50
Wheel Alignment	51
G0513X Electrical Components	53
G0513X Wiring Diagram	54
G0514X Electrical Components	55
G0514X Wiring Diagram	56
G0514X3 Electrical Components	57
G0514X3 Wiring Diagram	58
G0513X Main Parts.....	59
G0513X Fence/Guide Parts	60
G0513X Parts List.....	61
G0513X Labels	63
G0514X/G0514X3 Main Parts.....	64
G0514X/G0514X3 Fence/Guide Parts.....	65
G0514X/G0514X3 Labels	66
G0514X/G0514X3 Parts List.....	67
WARRANTY AND RETURNS	70

INTRODUCTION

Foreword

We are proud to offer the Model G0513X/G0514X/G0514X3 Extreme Series Bandsaw. This machine is part of a growing Grizzly family of fine wood-working machinery. When used according to the guidelines set forth in this manual, you can expect years of trouble-free, enjoyable operation and proof of Grizzly's commitment to customer satisfaction.

We are pleased to provide this manual with the Model G0513X/G0514X/G0514X3. It was written to guide you through assembly, review safety considerations, and cover general operating procedures. It represents our effort to produce the best documentation possible.

The specifications, drawings, and photographs illustrated in this manual represent the Model G0513X/G0514X/G0514X3 as supplied when the manual was prepared. However, owing to Grizzly's policy of continuous improvement, changes may be made at any time with no obligation on the part of Grizzly. For your convenience, we always keep current Grizzly manuals available on our website at **www.grizzly.com**. Any updates to your machine will be reflected in these manuals as soon as they are complete. Visit our site often to check for the latest updates to this manual!

Contact Info

If you have any comments regarding this manual, please write to us at the address below:

Grizzly Industrial, Inc.
c/o Technical Documentation Manager
P.O. Box 2069
Bellingham, WA 98227-2069

We stand behind our machines. If you have any service questions or parts requests, please call or write us at the location listed below.

Grizzly Industrial, Inc.
1203 Lycoming Mall Circle
Muncy, PA 17756
Phone: (570) 546-9663
Fax: (800) 438-5901
E-Mail: techsupport@grizzly.com
Web Site: <http://www.grizzly.com>



Identification

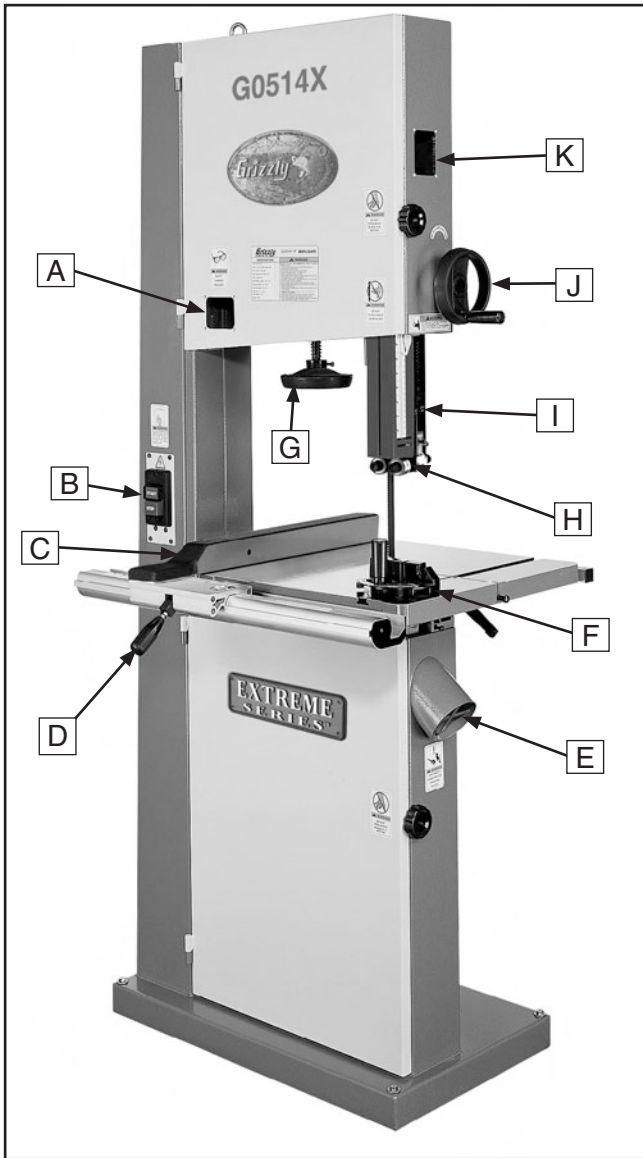

Figure 1. Bandsaw front view.

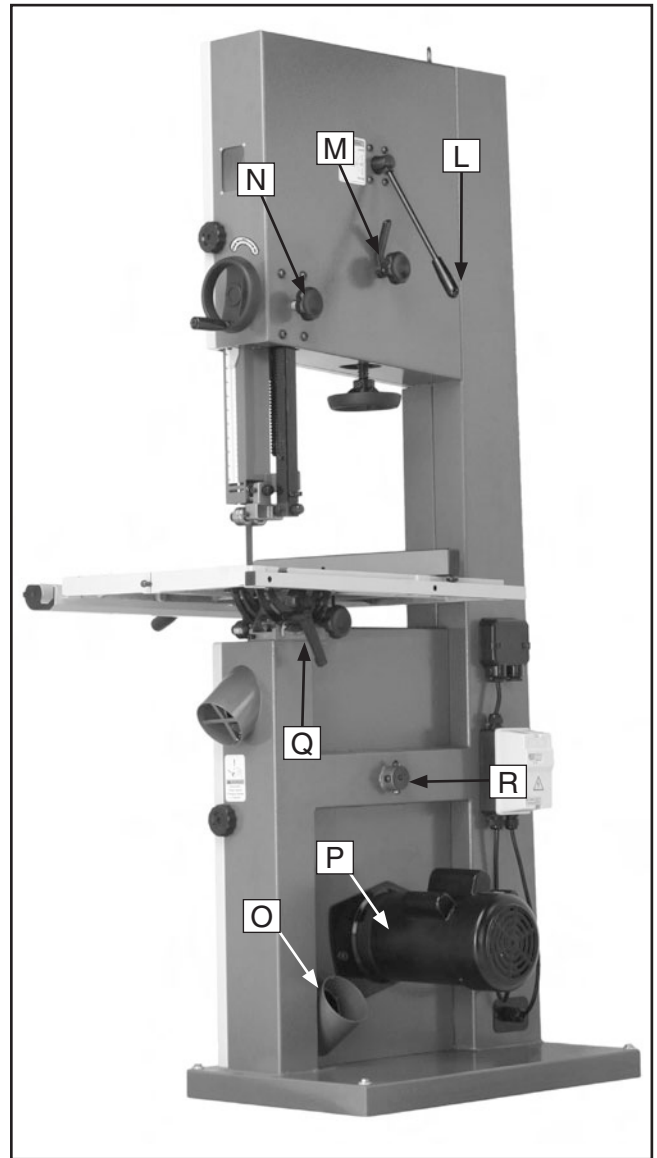

Figure 2. Bandsaw back view.

- A. Tension Indicator Window
- B. ON/OFF Switch
- C. Rip Fence
- D. Fence Locking Lever
- E. Dust Port 4"
- F. Miter Gauge
- G. Blade Tension Handwheel
- H. Ball Bearing Roller Guides
- I. Guide Post
- J. Guide Post Handwheel
- K. Blade Tracking Window

- L. Quick Release Blade Tension Lever
- M. Blade Tracking Knob
- N. Guide Post Lock Knob
- O. Dust Port 4"
- P. Motor
- Q. Table Tilt Controls
- R. Lower Wheel Adjustment Control



SECTION 1: SAFETY

WARNING

For Your Own Safety, Read Instruction Manual Before Operating this Machine

The purpose of safety symbols is to attract your attention to possible hazardous conditions. This manual uses a series of symbols and signal words which are intended to convey the level of importance of the safety messages. The progression of symbols is described below. Remember that safety messages by themselves do not eliminate danger and are not a substitute for proper accident prevention measures.

 **DANGER** Indicates an imminently hazardous situation which, if not avoided, WILL result in death or serious injury.

 **WARNING** Indicates a potentially hazardous situation which, if not avoided, COULD result in death or serious injury.

 **CAUTION** Indicates a potentially hazardous situation which, if not avoided, MAY result in minor or moderate injury. It may also be used to alert against unsafe practices.

NOTICE This symbol is used to alert the user to useful information about proper operation of the machine.

WARNING

Safety Instructions for Machinery

- 1. READ THROUGH THE ENTIRE MANUAL BEFORE STARTING MACHINERY.** Machinery presents serious injury hazards to untrained users.
- 2. ALWAYS USE ANSI APPROVED SAFETY GLASSES WHEN OPERATING MACHINERY.** Everyday eyeglasses only have impact resistant lenses—they are NOT safety glasses.
- 3. ALWAYS WEAR AN ANSI APPROVED RESPIRATOR WHEN OPERATING MACHINERY THAT PRODUCES DUST.** Wood dust is a carcinogen and can cause cancer and severe respiratory illnesses.
- 4. ALWAYS USE HEARING PROTECTION WHEN OPERATING MACHINERY.** Machinery noise can cause permanent hearing damage.
- 5. WEAR PROPER APPAREL. DO NOT** wear loose clothing, gloves, neckties, rings, or jewelry which may get caught in moving parts. Wear protective hair covering to contain long hair and wear non-slip footwear.
- 6. NEVER OPERATE MACHINERY WHEN TIRED, OR UNDER THE INFLUENCE OF DRUGS OR ALCOHOL.** Be mentally alert at all times when running machinery.



WARNING

Safety Instructions for Machinery

7. **ONLY ALLOW TRAINED AND PROPERLY SUPERVISED PERSONNEL TO OPERATE MACHINERY.** Make sure operation instructions are safe and clearly understood.
8. **KEEP CHILDREN AND VISITORS AWAY.** Keep all children and visitors a safe distance from the work area.
9. **MAKE WORKSHOP CHILD PROOF.** Use padlocks, master switches, and remove start switch keys.
10. **NEVER LEAVE WHEN MACHINE IS RUNNING.** Turn power **OFF** and allow all moving parts to come to a complete stop before leaving machine unattended.
11. **DO NOT USE IN DANGEROUS ENVIRONMENTS.** DO NOT use machinery in damp, wet locations, or where any flammable or noxious fumes may exist.
12. **KEEP WORK AREA CLEAN AND WELL LIT.** Clutter and dark shadows may cause accidents.
13. **USE A GROUNDED EXTENSION CORD RATED FOR THE MACHINE AMPERAGE.** Undersized cords overheat and lose power. Replace extension cords if they become damaged. DO NOT use extension cords for 220V machinery.
14. **ALWAYS DISCONNECT FROM POWER SOURCE BEFORE SERVICING MACHINERY.** Make sure switch is in OFF position before reconnecting.
15. **MAINTAIN MACHINERY WITH CARE.** Keep blades sharp and clean for best and safest performance. Follow instructions for lubricating and changing accessories.
16. **MAKE SURE GUARDS ARE IN PLACE AND WORK CORRECTLY BEFORE USING MACHINERY.**
17. **REMOVE ADJUSTING KEYS AND WRENCHES.** Make a habit of checking for keys and adjusting wrenches before turning machinery **ON**.
18. **CHECK FOR DAMAGED PARTS BEFORE USING MACHINERY.** Check for binding and alignment of parts, broken parts, part mounting, loose bolts, and any other conditions that may affect machine operation. Repair or replace damaged parts.
19. **USE RECOMMENDED ACCESSORIES.** Refer to the instruction manual for recommended accessories. The use of improper accessories may cause risk of injury.
20. **DO NOT FORCE MACHINERY.** Work at the speed for which the machine or accessory was designed.
21. **SECURE WORKPIECE.** Use clamps or a vise to hold the workpiece when practical. A secured workpiece protects your hands and frees both hands to operate the machine.
22. **DO NOT OVERREACH.** Keep proper footing and balance at all times.
23. **MANY MACHINES WILL EJECT THE WORKPIECE TOWARD THE OPERATOR.** Know and avoid conditions that cause the workpiece to "kickback."
24. **ALWAYS LOCK MOBILE BASES (IF USED) BEFORE OPERATING MACHINERY.**
25. **BE AWARE THAT CERTAIN DUST MAY BE HAZARDOUS** to the respiratory systems of people and animals, especially fine dust. Make sure you know the hazards associated with the type of dust you will be exposed to and always wear a respirator approved for that type of dust.



WARNING

Additional Safety Instructions for Bandsaws

- 1. BLADE CONDITION.** Do not operate with dull, cracked or badly worn blade. Dull blades require more effort to use and are difficult to control. Inspect blades for cracks and missing teeth before each use, and replace as required.
- 2. HAND PLACEMENT.** Never position fingers or thumbs in line with the cut. Serious personal injury could occur.
- 3. GUARDS.** Do not operate this bandsaw without the blade guard in place or with the doors open.
- 4. BLADE REPLACEMENT.** When replacing blades, make sure teeth face toward the workpiece and the blade is properly tensioned before operating.
- 5. WORKPIECE HANDLING.** Never hold small workpieces with your fingers during a cut. Always support/feed the workpiece with push stick, table support, vise, or some type of clamping fixture.
- 6. CUTTING TECHNIQUES.** Plan your cuts so you always cut out of the wood. **DO NOT** back the workpiece away from the blade while the saw is running. If you need to back the work out, turn the bandsaw **OFF** and wait for the blade to come to a complete stop, and **DO NOT** twist or put excessive stress on the blade while backing work away.
- 7. BLADE SPEED.** Allow blade to reach full speed before cutting.
- 8. LEAVING WORK AREA.** Never leave a machine running and unattended. Allow the bandsaw to come to a complete stop before you leave it unattended.
- 9. FEED RATE.** Always feed stock evenly and smoothly. **DO NOT** force or twist blade while cutting, especially when sawing small radii.
- 10. WORKPIECE MATERIAL.** This machine is designed to cut wood only. It is not designed to cut metal or use cutting fluid.
- 11. MAINTENANCE/SERVICE.** All inspections, adjustments, and maintenance are to be done with the power **OFF** and the plug removed from the outlet. Wait for all moving parts to come to a complete stop.
- 12. BLADE CONTROL.** Do not attempt to stop or slow the blade with your hand or a workpiece. Allow the blade to stop on its own, unless your machine is equipped with a brake.
- 13. EXPERIENCING DIFFICULTIES.** If at any time you are experiencing difficulties performing the intended operation, stop using the machine! Contact our Technical Support Department at (570) 546-9663.

WARNING

Like all machinery there is potential danger when operating this machine. Accidents are frequently caused by lack of familiarity or failure to pay attention. Use this machine with respect and caution to lessen the possibility of operator injury. If normal safety precautions are overlooked or ignored, serious personal injury may occur.

CAUTION

No list of safety guidelines can be complete. Every shop environment is different. Always consider safety first, as it applies to your individual working conditions. Use this and other machinery with caution and respect. Failure to do so could result in serious personal injury, damage to equipment, or poor work results.



SECTION 2: CIRCUIT REQUIREMENTS

Operation

⚠️ WARNING

Serious personal injury could occur if you connect the machine to the power source before you have completed the set up process. DO NOT connect the machine to the power source until instructed to do so.

Amperage Draw

The motor for your machine may draw the following amps at maximum load.

G0513X at 220V Single-Phase	10 Amps
G0513X at 110V*	20 Amps
G0514X at 220V Single-Phase	16 Amps
G0514X3 at 220V 3-Phase	9 Amps
G0514X3 at 440V 3-Phase**	4.5 Amps

Circuit Requirements

We recommend connecting this machine to a dedicated circuit with a verified ground, using the circuit breaker size given below. Never replace a circuit breaker with one of higher amperage without consulting a qualified electrician to ensure compliance with wiring codes. **If you are unsure about the wiring codes in your area or you plan to connect your machine to a shared circuit, you may create a fire hazard—consult a qualified electrician to reduce this risk.**

G0513X at 220V	15 Amp Circuit Breaker
G0513X at 110V*	30 Amp Circuit Breaker
G0514X	20 Amp Circuit Breaker
G0514X3 at 220V	15 Amp Circuit Breaker
G0514X3 at 440V**	15 Amp Circuit Breaker

*** To run on 110V, you MUST rewire the motor. Refer to the wiring diagram on Page 54.**

**** To run on 440V, you must rewire the motor and replace the 220V magnetic switch assembly with the 440V magnetic switch assembly (Part #P0514X3161A). Refer to the wiring diagram on Page 58 for wiring details.**

Plug Type

The cord set enclosed does not have a plug as the style of plug you require will depend upon the type of service you currently have or plan to install. We recommend using the following plugs for your machine on a dedicated circuit only (see **Figures 3–6** for examples):

G0513X at 220V	NEMA 6-15 Plug
G0513X at 110V*	NEMA 5-30 Plug
G0514X	NEMA 6-20 Plug
G0514X3 at 220V	NEMA L15-20 Plug
G0514X3 at 440V**	NEMA L16-20 Plug

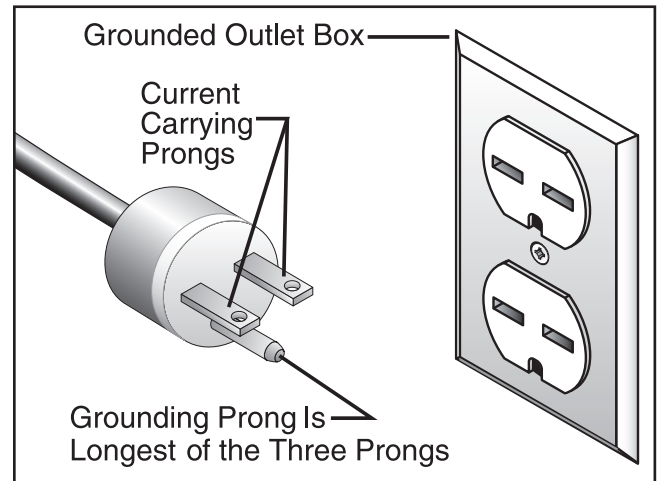

Figure 3. NEMA 6-15 plug and receptacle.

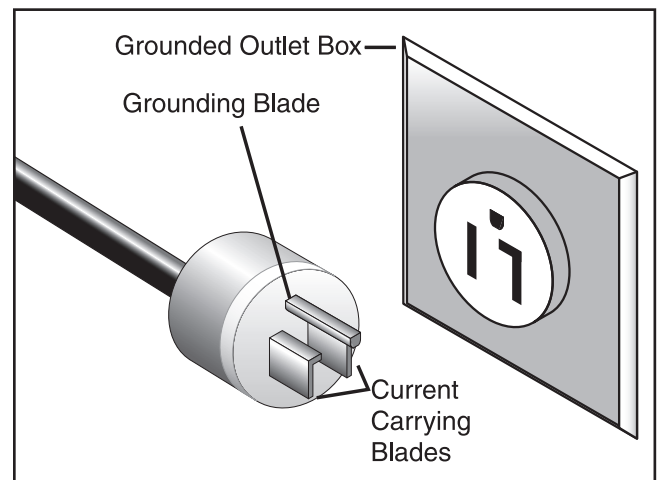

Figure 4. NEMA 5-30 plug and receptacle.



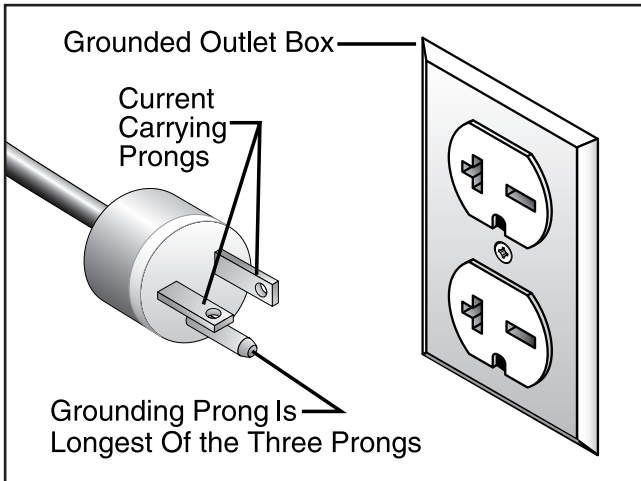

Figure 5. NEMA 6-20 plug and receptacle.

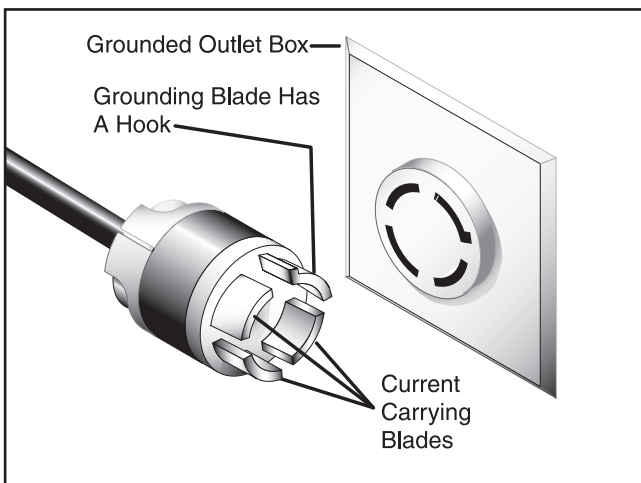
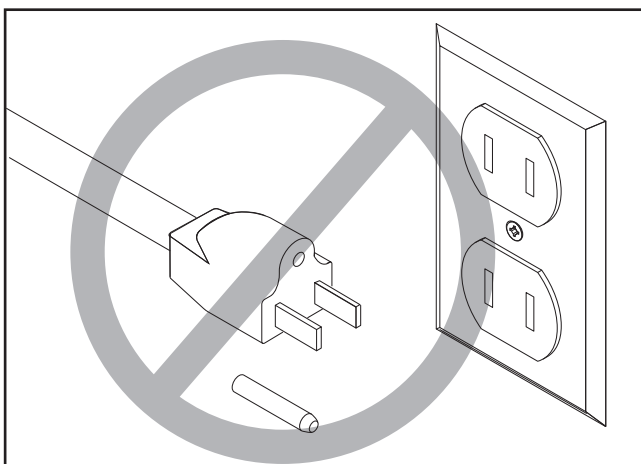

Figure 6. NEMA L15-20 plug and receptacle.



⚠ CAUTION

This machine must have a ground prong in the plug to help ensure that it is grounded. DO NOT remove ground prong from plug to fit into a two-pronged outlet! If the plug will not fit the outlet, have the proper outlet installed by a qualified electrician.

Grounding

In the event of an electrical short, grounding reduces the risk of electric shock. The grounding wire in the power cord must be properly connected to the grounding prong on the plug; likewise, the outlet must be properly installed and grounded. All electrical connections must be made in accordance with local codes and ordinances.

Extension Cords

We do not recommend the use of extension cords. Instead, arrange the placement of your equipment and the installed wiring to eliminate the need for extension cords.

If you find it absolutely necessary to use an extension cord with your machine, the extension cord must also contain a ground wire and plug pin.

110V Operation

Use at least a 10 gauge cord that does not exceed 50 feet in length!

220V Operation

Use at least a 12 gauge cord that does not exceed 50 feet in length!

440V Operation

Do not use an extension cord with 440V!

Phase Converter

When using a phase converter for 3-phase, the power from the manufactured power leg (sometimes called the wild wire) can fluctuate. Connect the manufactured power leg to the S terminal to prevent damage. The wire from the S terminal can handle some fluctuation because it goes directly to the motor. The power going to the R and T terminals must be consistent to prevent damage.



SECTION 3: SET UP

Set Up Safety

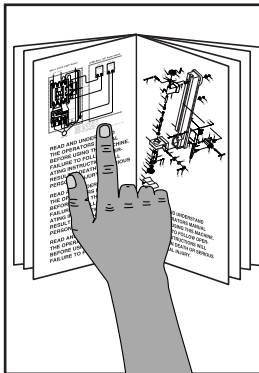

!WARNING

This machine presents serious injury hazards to untrained users. Read through this entire manual to become familiar with the controls and operations before starting the machine!

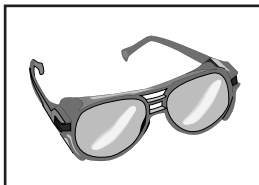

!WARNING

Wear safety glasses during the entire set up process!

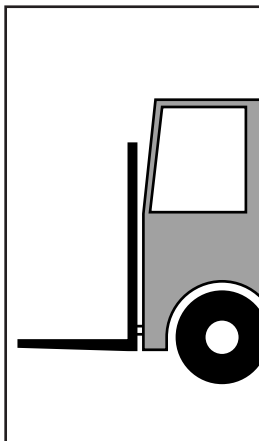

!WARNING

This is an extremely heavy machine. Serious personal injury may occur if safe moving methods are not followed. To be safe, you will need assistance and a forklift or pallet jack when moving the shipping crate.

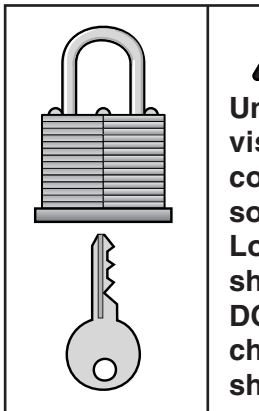

!CAUTION

Unsupervised children and visitors inside your shop could cause serious personal injury to themselves. Lock all entrances to the shop when you are away and **DO NOT** allow unsupervised children or visitors in your shop at any time!

Items Needed for Set Up

The following items are needed to complete the set up process, but are not included with your machine:

DESCRIPTION	Qty
• Safety Glasses (for each person)	1
• Machinist's Square	1
• Feeler Gauge 0.016"	1
• Straightedge	1
• Fine Ruler	1
• Dust Collector	1
• Dust Hoses 4"	2
• Hose Clamps	2
• Forklift	1
• 1000 Lb Capacity Chain or Strap w/Hook..	1

Unpacking

The Model G0513X/G0514X/G0514X3 was carefully packed when it left our warehouse. If you discover the machine is damaged after you have signed for delivery, *please immediately call Customer Service at (570) 546-9663 for advice.*

Save the containers and all packing materials for possible inspection by the carrier or its agent. *Otherwise, filing a freight claim can be difficult.*

When you are completely satisfied with the condition of your shipment, you should inventory the contents.



Inventory

After all the parts have been removed from the crate, you should have the following items:

Crate Contents (Figure 7 & 8):	Qty
A. Bandsaw (not shown).....	1
B. Table.....	1
C. Miter Gauge.....	1
D. Back Square Tube.....	1
E. Resaw Fence	1
F. Front Rail	1
G. Fence Assembly.....	1

Hardware and Tools:	Qty
• Eye Bolt M10-1.5 (may be installed).....	1
• Flat Washers 8mm (Table, Pos. Stop, Fence)	7
• Lock Washers 8mm (Table).....	4
• Hex Bolts M8-1.25 x 16 (Table)	4
• Hex Bolt M8-1.25 x 90 (Pos. Stop)	1
• Hex Nuts M8-1.25 (Pos. Stop, Fence).....	2
• Table Pin	1
• Table Insert	1
• Cap Screws M6-1 x 16 (Fence)	2
• Hex Bolts M6-1 x 20 (Fence)	2
• Fence Handle M8-1.25 x 22 (Fence)	1
• Lock Washers 6mm (Fence).....	2
• Flat Washers 6mm (Fence).....	2
• Rail Pad M6 x 18 (Fence)	1
• Hex Nut M6-1 (Fence).....	1
• Lock Handle M8-1.25 x 44 (Fence).....	1
• Moving Plate (Fence).....	1
• Hex Wrench 5mm & 8mm.....	1 Ea
• Open End Wrench 10 x 13mm.....	1

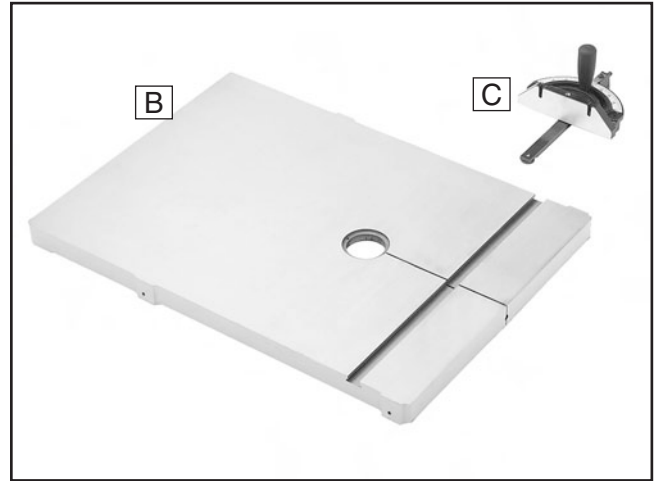

Figure 7. Bandsaw components.

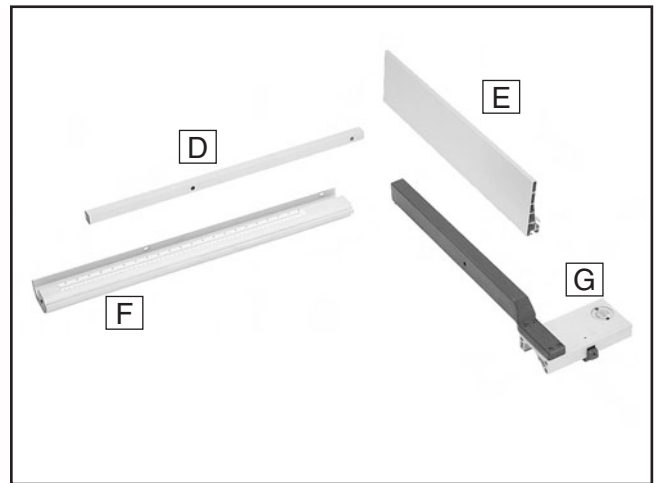

Figure 8. Fence components.

In the event that any nonproprietary parts are missing (e.g. a nut or a washer), we would be glad to replace them, or for the sake of expediency, replacements can be obtained at your local hardware store.

NOTICE

Some hardware/fasteners on the inventory list may arrive pre-installed on the machine. Check these locations before assuming that any items from the inventory list are missing.



Hardware Recognition Chart

USE THIS CHART TO MATCH UP HARDWARE DURING THE ASSEMBLY PROCESS.

MEASURE BOLT DIAMETER BY PLACING INSIDE CIRCLE

- #10
- 1/4"
- 5/16"
- 3/8"
- 7/16"
- 1/2"

- 4mm
- 6mm
- 8mm
- 10mm
- 12mm
- 16mm

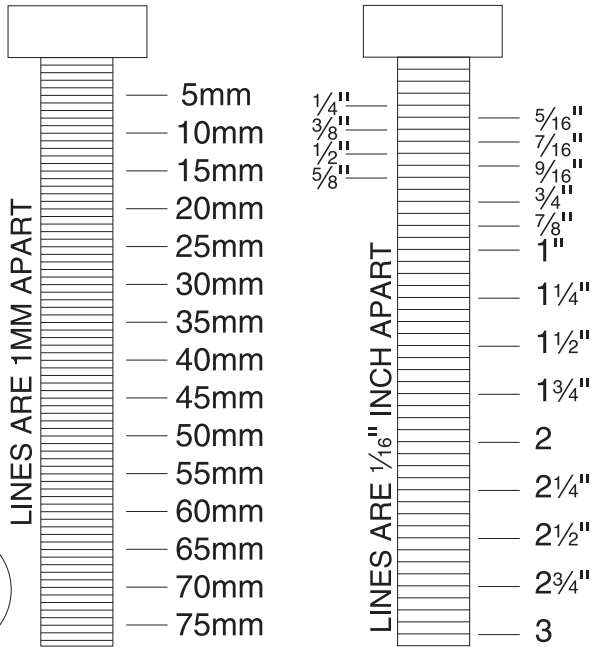
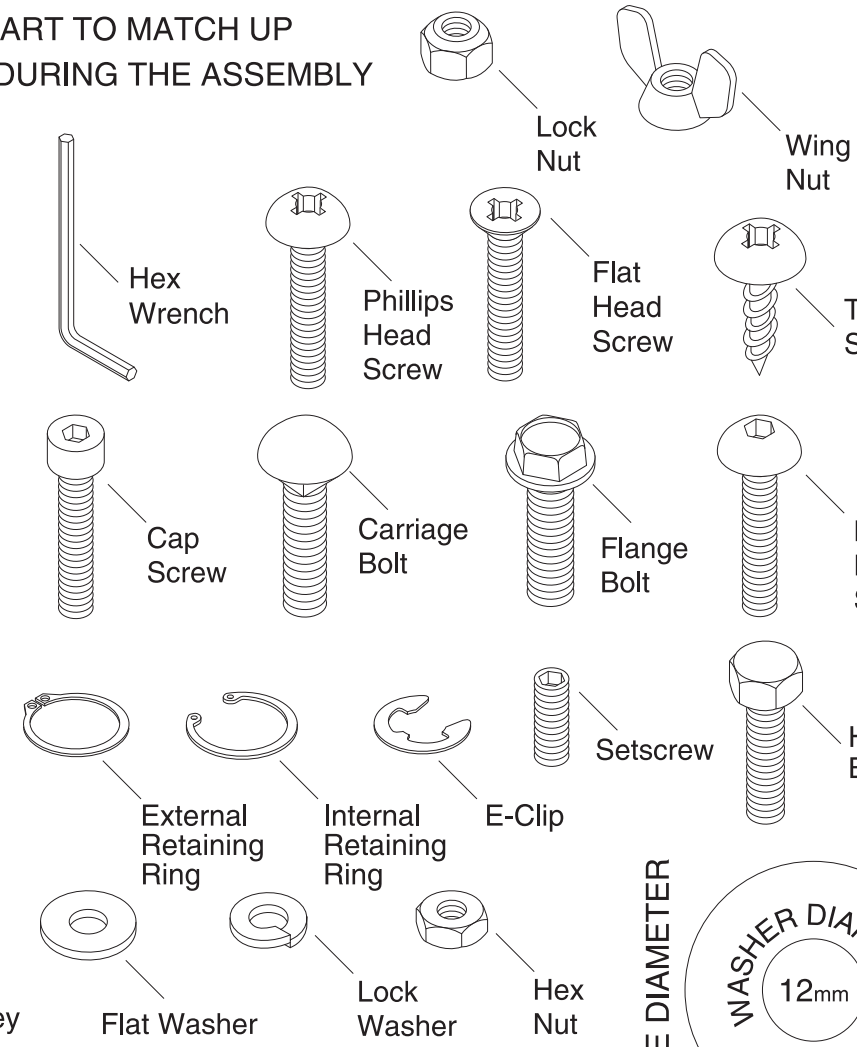

WASHERS ARE MEASURED BY THE INSIDE DIAMETER

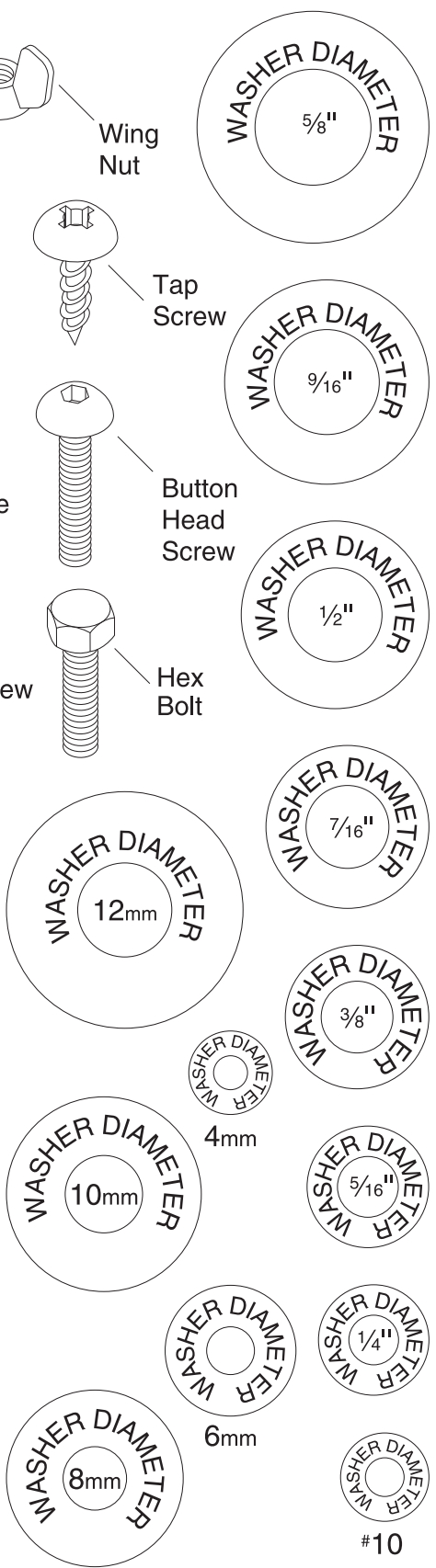

Clean Up

The unpainted surfaces are coated with a waxy oil to protect them from corrosion during shipment. Remove this protective coating with a solvent cleaner or citrus-based degreaser such as Grizzly's G7895 Degreaser. To clean thoroughly, some parts may need to be removed. **For optimum performance from your machine, make sure you clean all moving parts or sliding contact surfaces that are coated.** Avoid chlorine-based solvents, such as acetone or brake parts cleaner, as they may damage painted surfaces should they come in contact. Always follow the manufacturer's instructions when using any type of cleaning product.

	<p>⚠ WARNING Gasoline and petroleum products have low flash points and could cause an explosion or fire if used to clean machinery. DO NOT use gasoline or petroleum products to clean the machinery.</p>
--	---

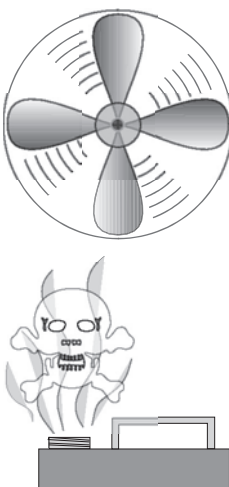
	<p>⚠ CAUTION Many of the solvents commonly used to clean machinery can be toxic when inhaled or ingested. Lack of ventilation while using these solvents could cause serious personal health risks or fire. Take precautions from this hazard by only using cleaning solvents in a well ventilated area.</p>
---	---

Site Considerations

Floor Load

Refer to the **Machine Data Sheet** for the weight and footprint specifications of your machine. Some floors may require additional reinforcement to support both the machine and operator.

Working Clearances

Consider existing and anticipated needs, size of material to be processed through each machine, and space for auxiliary stands, work tables or other machinery when establishing a location for your new machine. See **Figures 9 & 10** for the minimum working clearances.

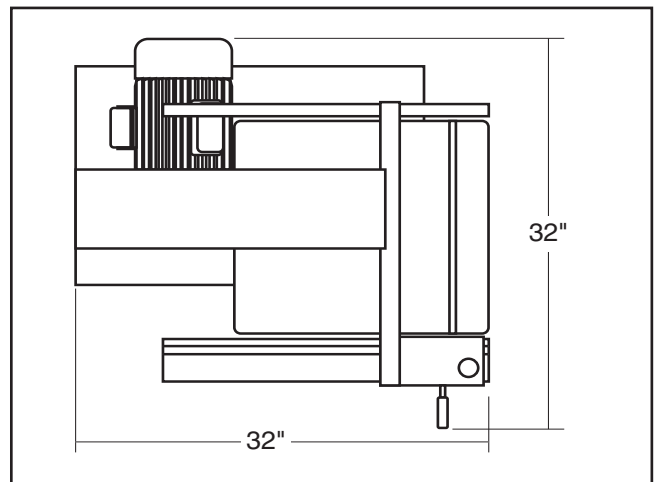

Figure 9. G0513X minimum working clearances.

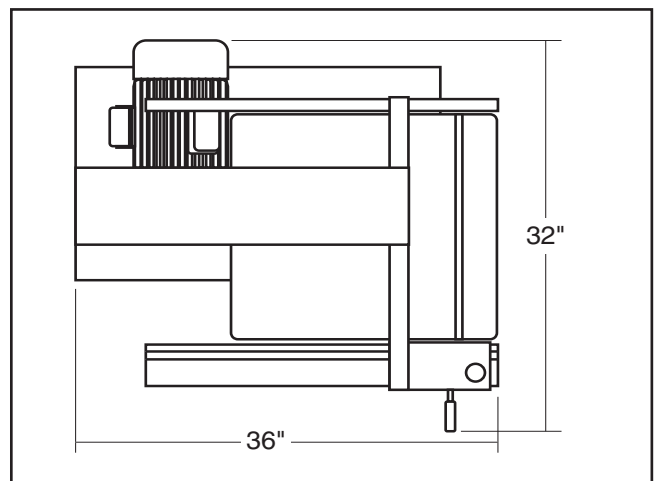

Figure 10. G0514X and G0514X3 minimum working clearances.



Moving & Placing Base Unit

!WARNING

This is an extremely heavy machine. Serious personal injury may occur if safe moving methods are not followed. To be safe, you will need assistance and a forklift or a hoist when removing the machine from the crate. Use a chain or a lifting strap with a minimum of 1000 lbs. lifting capacity. If the chain or lifting strap breaks, serious personal injury may occur.

Special care should be taken when moving this bandsaw. Only use the following methods to lift or move this bandsaw.

To move and place the bandsaw:

1. Use a forklift to move the bandsaw on the pallet to its final location.
2. Unbolt the bandsaw from the pallet.
3. Install the eye bolt shown in **Figure 11** if it is not already installed (make sure it is threaded all the way in), then place the lifting hook through the eye bolt and lift slowly with a forklift.
4. Remove the pallet and slowly set the bandsaw into position.

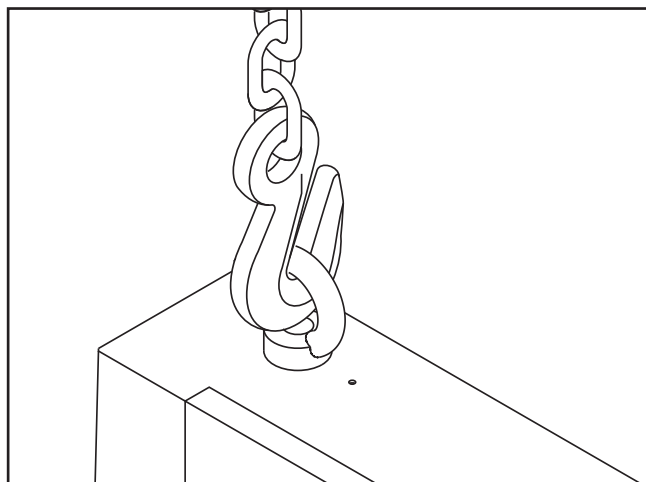

Figure 11. Lifting the bandsaw.

Mounting

We recommend mounting your new machine to the floor. Because floor materials may vary, floor mounting hardware is not included. You may also mount your machine to a mobile base that has wheel locking or wheel retracting capabilities that keep the mobile base from rolling when not in use.

Bolting to Concrete Floors

Lag shield anchors with lag bolts (**Figure 12**) and anchor studs (**Figure 13**) are two popular methods for anchoring an object to a concrete floor. We suggest you research the many options and methods for mounting your machine and choose the best that fits your specific application.

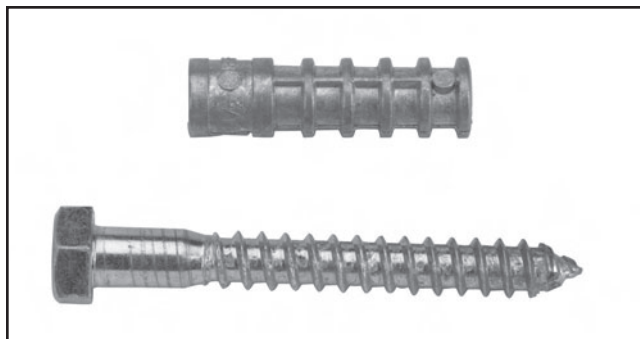

Figure 12. Typical lag shield anchor and bolt.

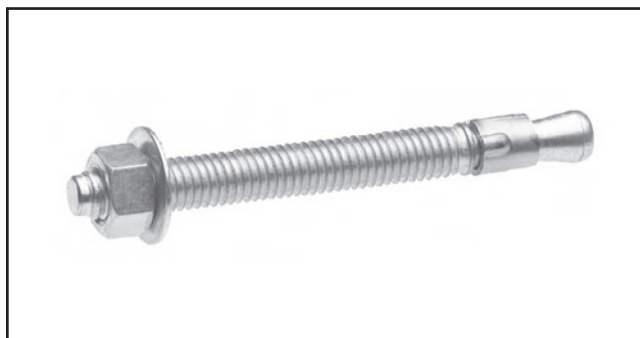

Figure 13. Typical anchor stud.

NOTICE

Anchor studs are stronger and more permanent alternatives to lag shield anchors; however, they will stick out of the floor, which may cause a tripping hazard if you decide to move your machine.



Table

The table is heavy and requires two people to lift it onto the trunnions. The saw blade should also be removed to make table installation easier.

Components and Hardware Needed:	Qty
Table.....	1
Hex Bolts M8-1.25 x 16.....	4
Lock Washers 8mm.....	4
Flat Washers 8mm.....	4
Table Pin.....	1
Table Insert.....	1

To install the table:

1. Loosen blade tension by rotating the quick release tension lever clockwise as shown in **Figure 14**.

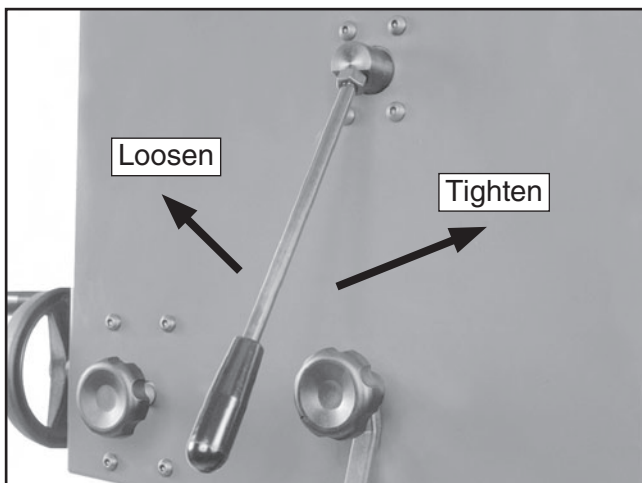

Figure 14. Quick release tension lever.

2. Adjust the upper and lower blade guides away from the blade. Refer to **Adjusting Blade Guide Bearings** on **Page 29** for more details.

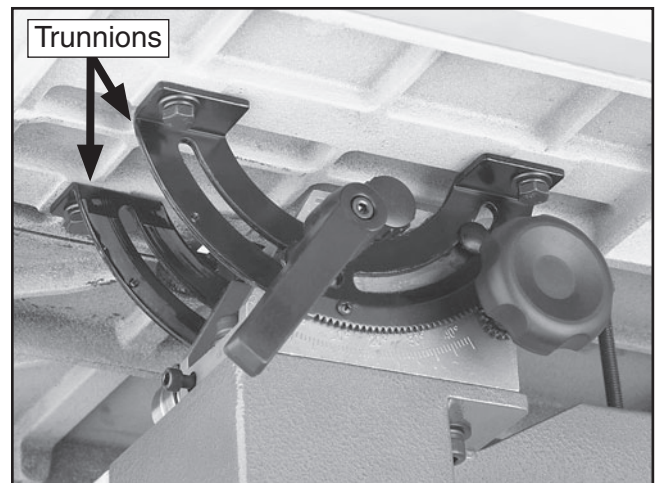

Figure 15. Mounting the table.

3. Open the upper and lower wheel covers, and slide the blade off of both wheels.



4. With the help of another person, lift the table onto the trunnions.
5. Secure the table to the trunnions as shown in **Figure 15** with the supplied hex bolts and washers.



6. With the blade teeth pointing downward, slide the blade through the table slot.
7. Slide the blade through the upper and lower blade guides, and mount it over the upper and lower wheels.
8. Tighten the quick release tension lever, then install the table insert and table pin.
9. Keep the upper and lower blade guides adjusted away from the blade until the blade tracking and tension have been adjusted.



Blade Tracking

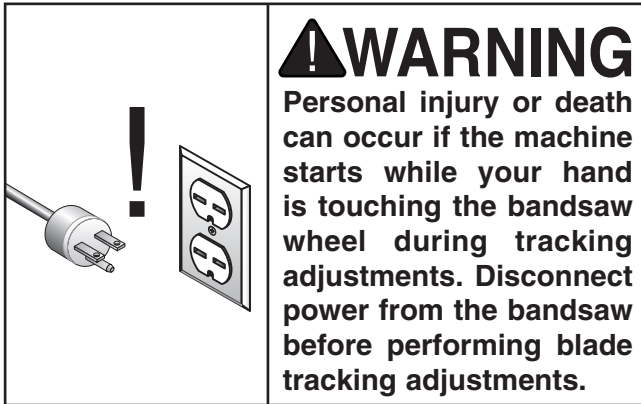

The blade tracking is primarily affected by the tilt of the upper wheel, also known as "Center Tracking"; and the alignment of both wheels, also known as "Coplanar Tracking." (For Coplanar Tracking, see the **Wheel Alignment** instructions on **Page 51**.)

The wheels on this bandsaw were aligned at the factory, so Center Tracking is the only adjustment that needs to be performed when the saw is new.

To center track the blade:

1. DISCONNECT BANDSAW FROM POWER!
2. Make sure the upper and lower blade guides are adjusted away from the blade.
3. Engage the quick tension lever and turn the blade tension handwheel until the tension scale (**Figure 16**) reads between 4 and 6.

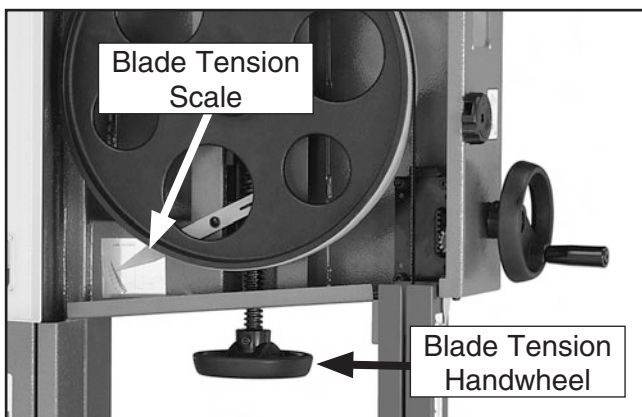

Figure 16. Blade tensioning controls.

4. Spin the upper wheel by hand at least three times and watch how the blade rides on the crown of the wheel. Refer to **Figure 17** for an illustration of this concept.

—If the blade rides in the center of the upper wheel and is centered on the peak of the wheel crown, then the bandsaw is already tracked properly and no further adjustments are needed at this time.

—If the blade does not ride in the center of the upper wheel and is not centered on the peak of the wheel crown, then continue with the following steps.

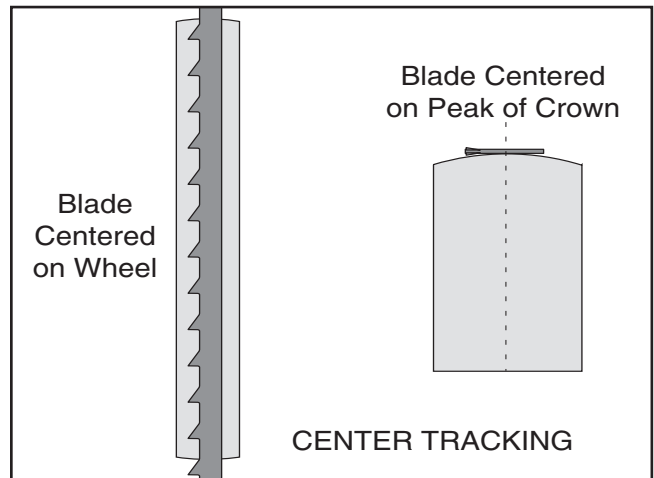

Figure 17. Center tracking profiles.



- Loosen the lock lever (**Figure 18**) so that the blade tracking knob can rotate.

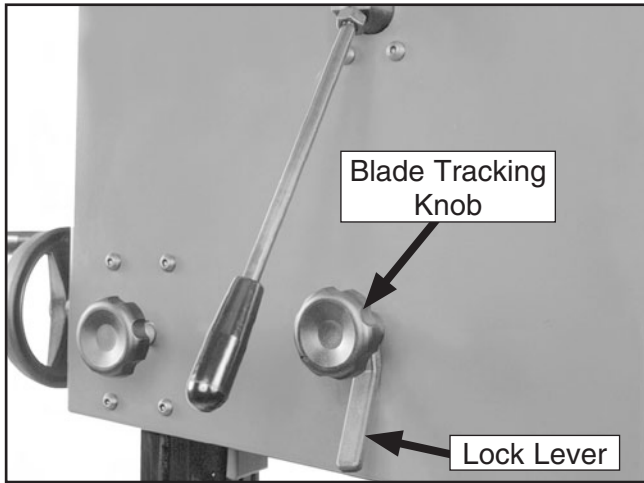

Figure 18. Blade tracking controls.

- Spin the upper wheel with one hand and rotate the tracking control knob with the other hand to make the blade ride in the center of the bandsaw wheel tire.
- Tighten the tracking control lock knob and close the upper wheel cover.

For the best performance from your saw, regularly maintain proper tracking of the blade.

NOTICE

Changes in the blade tension may change the blade tracking.

Positive Stop

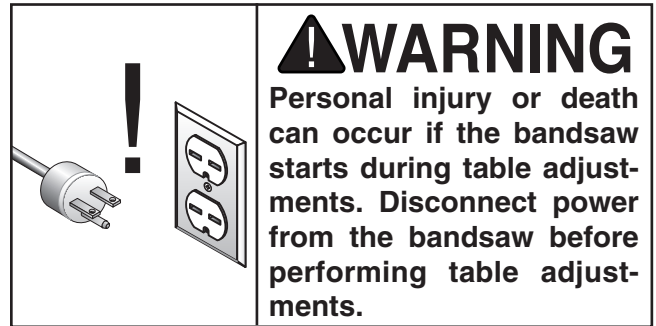

The positive stop allows the table to be quickly and accurately returned to the horizontal (0°) position after being adjusted to a different angle.

Components and Hardware Needed:	Qty
Hex Bolt M8-1.25 x 90.....	1
Hex Nut M8-1.25	1

To install the positive stop:

- Thread the M8-1.25 hex nut halfway onto the M8-1.25 x 90 hex bolt (this is the positive stop bolt).
- Thread the positive stop bolt into the threaded hole on bandsaw body as shown in **Figure 19**.

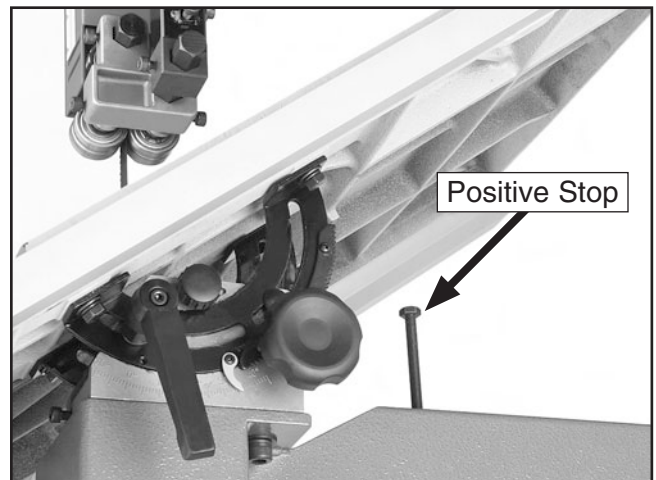

Figure 19. Installed positive stop bolt.



To set the positive stop:

1. DISCONNECT BANDSAW FROM POWER!
2. Adjust the blade tension until the mark on the blade tension scale is between 4 and 6.
3. Loosen the hex nut that locks the positive stop bolt in place.
4. Raise the guide post and place a machinist's square on the table next to the side of the blade as illustrated in **Figure 20**. Adjust the table square with the blade, then secure with the table tilt knobs.

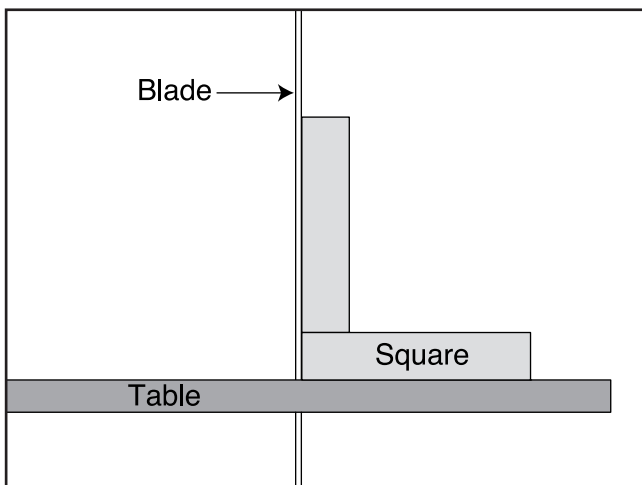

Figure 20. Squaring table to blade.

5. Adjust the positive stop bolt to the table and secure it by tightening the hex nut against the trunnion bracket.
6. Check the adjustment for accuracy once you have tightened the hex nut.
7. Loosen the screw on the pointer, but do not remove it.
8. Align the tip of the pointer with the 0° mark on the table tilt scale.
9. Tighten the screw on the pointer so that the pointer is locked in place.

Dust Collection

CAUTION

DO NOT operate this bandsaw without an adequate dust collection system. This saw creates substantial amounts of wood dust while operating. Failure to use a dust collection system can result in short and long-term respiratory illness.

Recommended CFM at Each Dust Port: 400
Do not confuse this CFM recommendation with the rating of the dust collector. To determine the CFM at the dust port, you must take into account many variables, including the CFM rating of the dust collector, the length of hose between the dust collector and the machine, the amount of branches or wyes, and the amount of other open lines throughout the system. Explaining this calculation is beyond the scope of this manual. If you are unsure of your system, consult an expert or purchase a good dust collection "how-to" book.

To connect a dust collection hose:

1. Fit a 4" dust hose over each dust port, as shown in **Figure 21**, and secure in place with a hose clamp.
2. Tug each hose to make sure it does not come off. **Note:** A tight fit is necessary for proper performance.



Figure 21. Dust hose attached to dust port.

3. Attach the dust hoses to a dust collector.



Installing Fence

Components and Hardware Needed:	Qty
Fence Assembly	1
Back Square Tube	1
Front Rail	1
Resaw Fence.....	1
Cap Screws M6-1 x 16.....	2
Hex Bolts M6-1 x 20.....	2
Lock Washers 6mm.....	2
Flat Washers 6mm	2
Fence Handle M8-1.25 x 22.....	1
Hex Nut M8-1.25	1
Rail Pad M6-1 x 18.....	1
Hex Nut M6-1	1
Flat Washer 8mm	1
Lock Handle M8-1.25 x 44	1
Moving Plate.....	1

To install the fence:

1. Attach the back square tube to the table with the cap screws as shown in **Figure 22**.
2. Attach the front rail with the hex bolts, lock washers, and flat washers as shown in **Figure 22**.

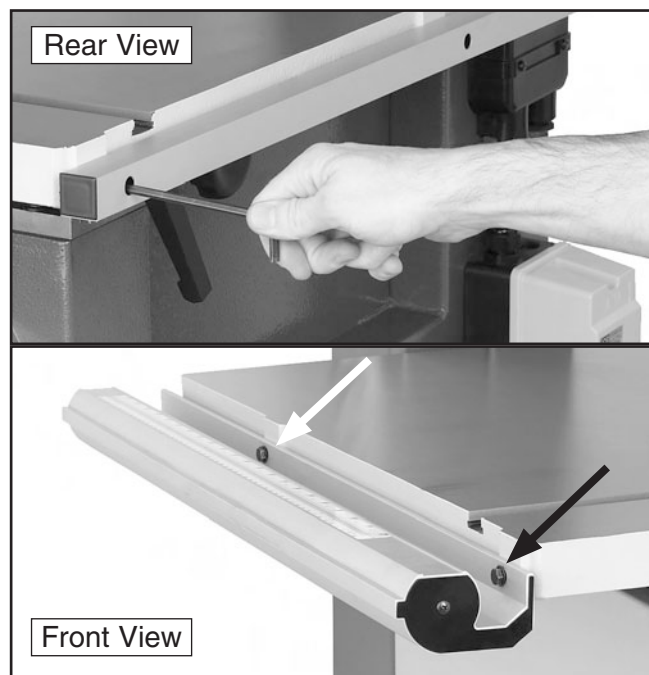

Figure 22. Rail installation.

3. Install an M8-1.25 hex nut on the fence handle, then thread the handle into the fence assembly (**Figure 23**). Tighten the hex nut against the fence pivot block to secure the handle.

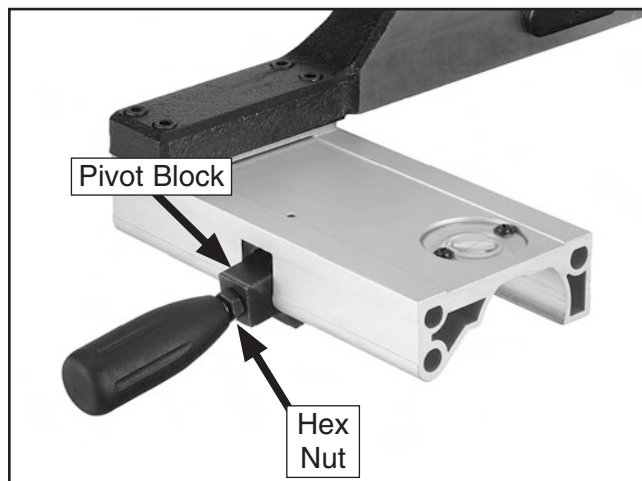

Figure 23. Handle installed on fence assembly.

4. Thread the M6-1 hex nut onto the rail pad, then thread the rail pad into the fence (see **Figure 24**).

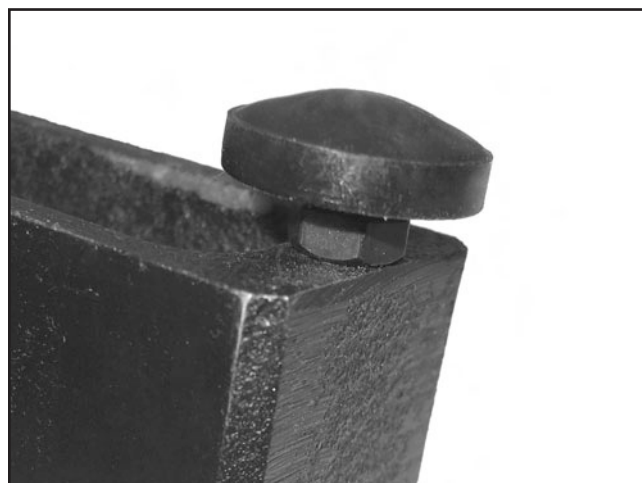

Figure 24. Installed rail pad.

5. Place the 8mm flat washer on the lock handle, slide it through the hole in the fence, then thread the moving plate onto the end of the lock handle threads.



- Slide the resaw fence over the moving plate, as shown in **Figure 25**, so the moving plate fits inside the channel of the resaw fence.

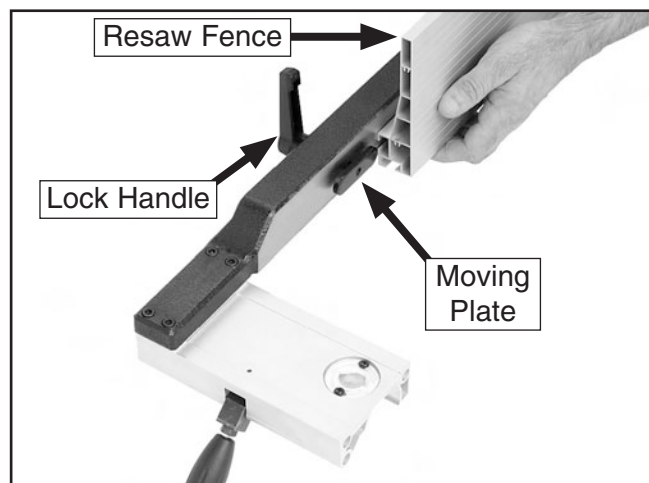

Figure 25. Attaching resaw fence to standard fence.

- Tighten the lock handle.
- Pull the fence handle up and place the fence assembly on the fixed rail as shown in **Figure 26**.

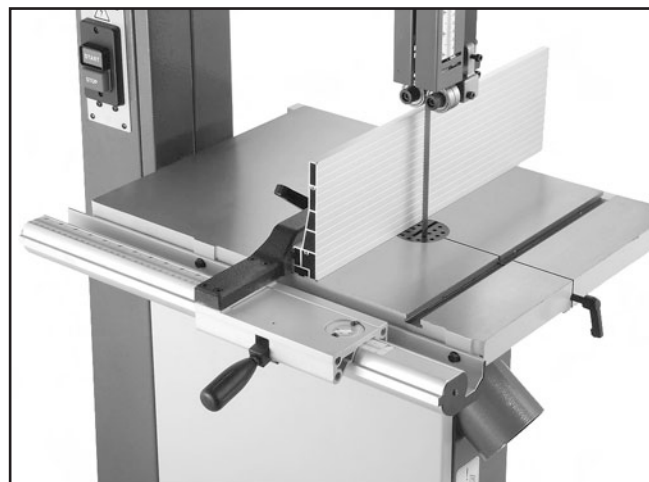

Figure 26. Correctly installed fence.

- Push the fence handle down to lock the fence assembly in place.
- Adjust the rail pad until there is an even gap between the bottom of the fence and the table, then tighten the hex nut against the fence.

Test Run

Once the assembly is complete and you have finished the **Blade Tracking** procedure, you need to test run the machine to continue with the remainder of the adjustments.

If, during the test run, you cannot easily locate the source of an unusual noise or vibration, stop using the machine immediately, then contact our service department for further assistance.



To test run the machine:

- Make sure that you have completed the **Blade Tracking** procedure before continuing.
- Make sure that the blade guides are adjusted as far away from the blade as possible, and that the blade is not touching the table or table insert.
- Refer to **CIRCUIT REQUIREMENTS** on **Page 14**, and connect the plug to the power cord.
- Make sure that any tools or foreign objects have been removed from the machine.
- Plug the machine into the power source.
- Turn the bandsaw **ON**.
- Listen to and watch the bandsaw for abnormal noises or actions. The bandsaw should run smoothly with little or no vibration or rubbing noises. Strange or unusual noises **MUST** be investigated and corrected before operating the machine further—always turn **OFF** and unplug the machine when investigating or correcting potential problems.



Tensioning Blade

A properly tensioned blade is essential for making accurate cuts and is required before making many bandsaw adjustments. (Everytime you replace the blade, you should perform this procedure because all blades tension differently.)

To tension the bandsaw blade:

1. Complete the **Test Run** procedure and make sure the blade is tracking properly.
2. Raise the upper blade guide assembly as high as it will go, and adjust the upper and lower guide blocks as far away from the blade as possible. **Note:** *This procedure will NOT work if the guide blocks have any contact with the blade.*
3. Engage the quick tension lever to the tightened position and turn the blade tension handwheel until the tension scale reads between 4 and 6.
4. Turn the bandsaw **ON**.
5. Slowly release the tension one quarter of a turn at a time. When you see the bandsaw blade start to flutter, stop decreasing the tension.
6. Now, slowly increase the tension until the blade stops fluttering, then tighten the tension another quarter turn.
7. Look at what the tension gauge reads and use that as a guide for tensioning that blade in the future. **Note:** *Always detension the blade after use to increase blade life and reduce strain on the bandsaw components.*
8. Re-adjust the blade tracking as instructed on **Page 22**.

Adjusting Support Bearings

NOTICE

Whenever changing a blade or adjusting tension and tracking, the upper and lower blade support bearings and blade guide bearings must be properly adjusted before cutting operations.

The support bearings are positioned behind the blade for support during cutting operations. Proper adjustment of the support bearings is an important part of making accurate cuts and also keeps the blade teeth from coming in contact with the guide bearings while cutting.

To adjust the upper support bearings:

1. **DISCONNECT BANDSAW FROM POWER!**
2. Make sure the blade is tracking properly and that it is correctly tensioned.
3. Familiarize yourself with the upper support bearing controls shown in **Figure 27**.

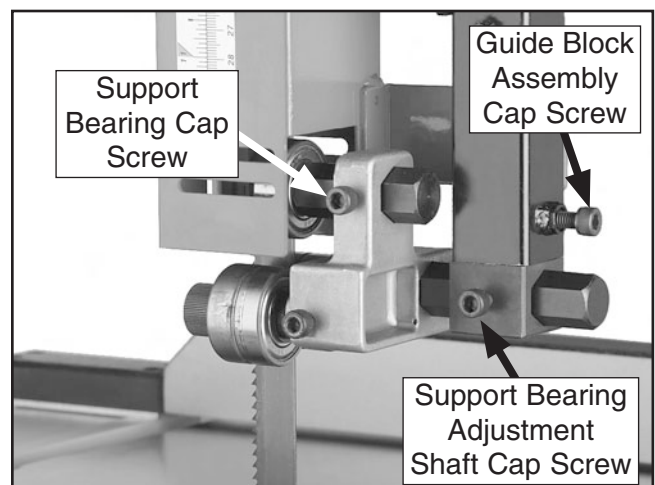

Figure 27. Upper support bearing controls.

4. Loosen the guide block assembly cap screw and rotate the blade guide assembly side-to-side, until the blade is perpendicular with the face of the support bearing as illustrated in **Figure 28**.



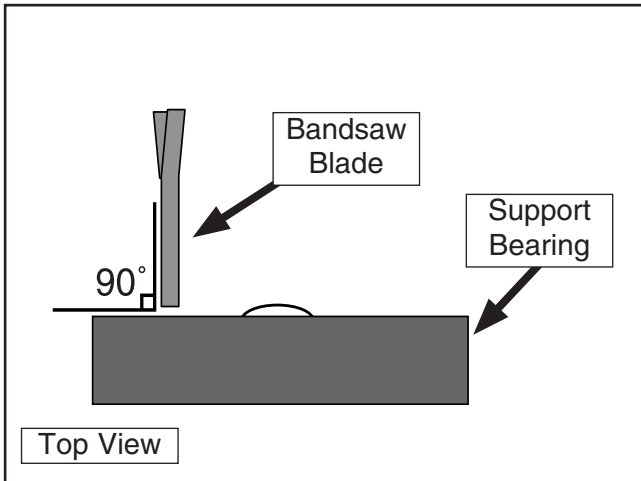

Figure 28. Blade should be perpendicular (90°) to the face of the support bearing.

5. Tighten the assembly cap screw.
6. Loosen the cap screw on the support bearing adjustment shaft.
7. Place a 0.016" feeler gauge between the support bearing and the blade, and position the bearing 0.016" away from the back of the blade as illustrated in **Figure 29**.

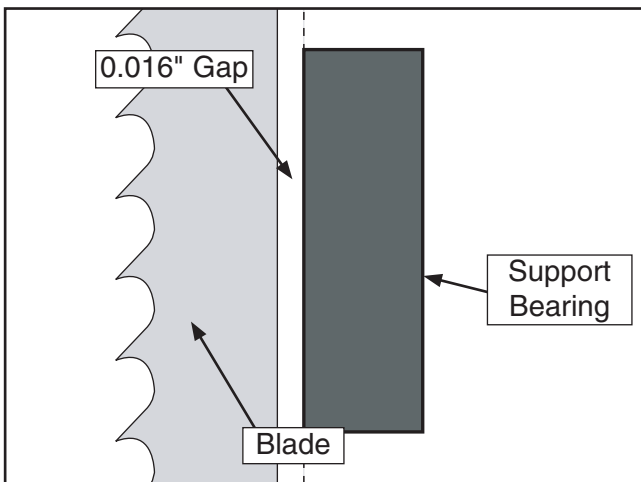

Figure 29. Blade should be aligned approximately 0.016" away from the bearing edge.

Note: For a quick gauge, fold a dollar bill in half twice (four thicknesses of a dollar bill is approximately 0.016") and place it between the support bearing and the blade as shown in **Figure 30**.

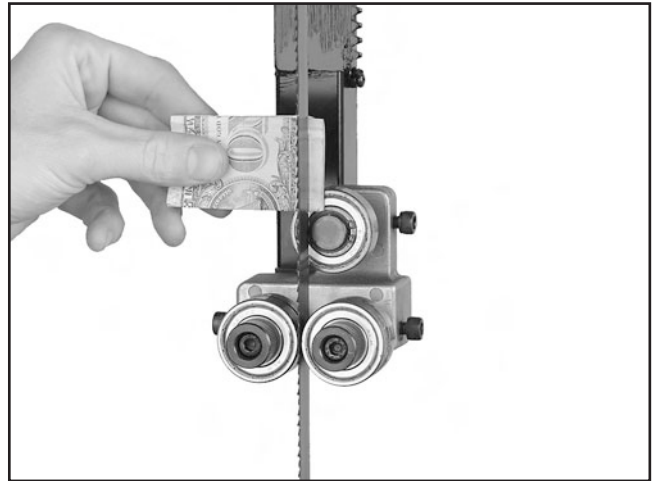

Figure 30. Dollar bill folded twice to make an approximate 0.016" gauge.

8. Tighten the cap screw to keep the support bearing locked in place.

To adjust the lower support bearings:

1. DISCONNECT BANDSAW FROM POWER!
2. Make sure that the blade is tracking properly and is correctly tensioned.
3. Familiarize yourself with the lower support bearing controls shown in **Figure 31**.

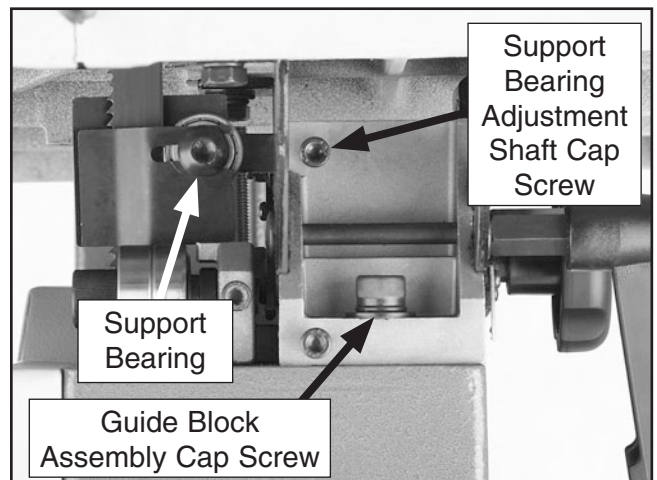

Figure 31. Lower support bearing controls.



4. Check to make sure the guide block assembly is perpendicular with the face of the support bearing as illustrated in **Figure 28**.

—If the guide block assembly is perpendicular to the face of the support bearing, continue on to the next step.

—If the guide block assembly is not perpendicular to the support bearing, loosen the guide block assembly cap screws and rotate the blade guide assembly side-to-side until the blade is perpendicular with the face of the support bearing, then retighten the cap screws. **Note:** *The table must be re-aligned with the blade after the lower guide block assembly is adjusted. Refer to **Page 30**.*

5. Loosen the cap screw on the support bearing adjustment shaft.
6. Place a 0.016" feeler gauge between the support bearing and the blade, and position the bearing 0.016" away from the back of the blade as illustrated in **Figure 29** or use a dollar bill as shown in **Figure 30**.
7. Tighten the cap screw to keep the support bearing locked in place.

Adjusting Blade Guide Bearings

The blade guides provide side-to-side support to help keep the blade straight while cutting. The blade guides are designed to be adjusted in two ways—forward/backward and side-to-side.

To adjust the upper and lower blade guides:

1. Make sure the blade is tracking properly and that it is correctly tensioned.
2. DISCONNECT BANDSAW FROM POWER!

3. Familiarize yourself with the blade guide controls shown in **Figure 32**.

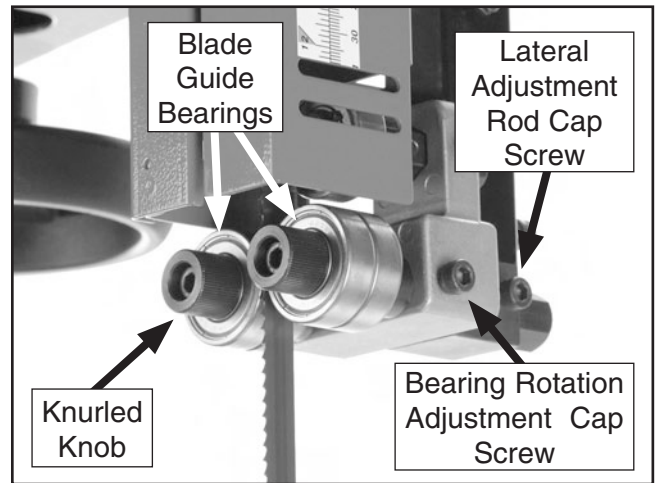

Figure 32. Blade guide controls.

4. Loosen the cap screw on the lateral adjustment rod and adjust the blade guides until the edges of the bearings are $\frac{1}{16}$ " behind the blade gullets as illustrated in **Figure 33**.

Note: *The $\frac{1}{16}$ " spacing is ideal, although with larger blades it may not be possible. In such cases, adjust the guide bearings as far forward as possible to the blade gullets, and still maintain the proper support bearing spacing adjustment.*

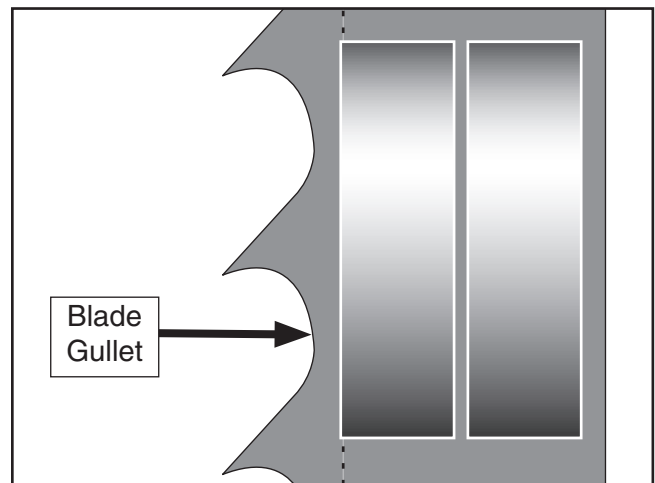

Figure 33. Lateral adjustment of blade guides.

NOTICE

Make sure that the blade teeth will not contact the guide bearings when the blade is against the rear support bearing during the cut or the blade teeth will be ruined.

5. Tighten the cap screw on the lateral adjustment rod.
6. Loosen the bearing rotation adjustment cap screws.
7. Rotate the knurled knob to position the bearings 0.004" away from the blade. **Note:** 0.004" is approximately the thickness of a dollar bill.
8. Tighten the cap screw to lock the blade guide bearings in position.
9. Repeat this procedure for the lower guides.

NOTICE

Whenever changing a blade or adjusting tension and tracking, the upper and lower blade support bearings and guide bearings must be properly adjusted before cutting operations.

Aligning Table

To ensure cutting accuracy when the table is first installed, the table should be aligned so that the miter slot is parallel to the bandsaw blade. This procedure works best with a $\frac{3}{4}$ " blade installed.

To align the table so the miter slot is parallel to the bandsaw blade:

1. Make sure that the blade is tracking properly and that it is correctly tensioned.
2. DISCONNECT BANDSAW FROM POWER!
3. Loosen the trunnion bolts that secure the trunnions to the table.
4. Place an accurate straightedge along the blade. The straightedge should lightly touch both the front and back of the blade. **Note:** Make sure the straightedge does not go across a tooth.
5. Use a fine ruler to gauge the distance between the straightedge and the miter slot. The distance you measure should be the same at both the front and the back of the table (see **Figure 34**).
6. Adjust the table as needed for proper alignment.
7. Tighten the trunnion bolts.

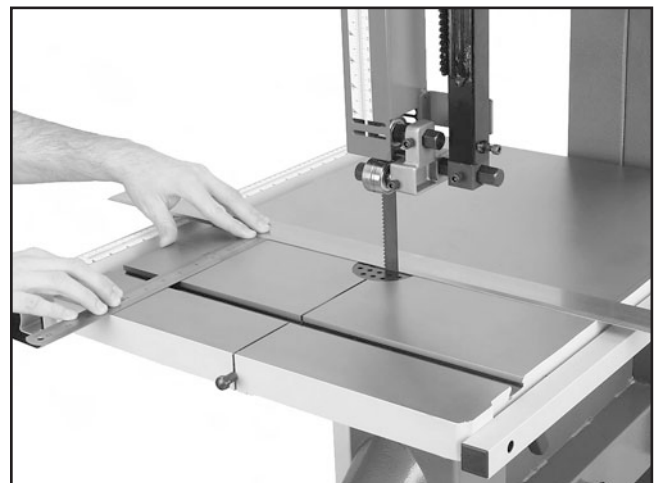

Figure 34. Measuring for miter slot to be parallel with blade.



Aligning Fence

To ensure cutting accuracy when the fence is first installed, the fence should be aligned with the miter slot.

To align the fence parallel with the miter slot:

1. If the fence is mounted on the left-hand side of the blade, remove it and remount it next to the miter slot.
2. Loosen the four cap screws located on the top face of the fence (**Figure 35**).



Figure 35. Four fence cap screws.

3. Adjust the fence face parallel with the edge of the miter slot.
4. Tighten the four cap screws, being careful not to move the fence.

NOTICE

Adjusting the fence parallel to the miter slot does not guarantee straight cuts. The miter slot may need to be adjusted parallel to the side of the blade. Refer to the "Aligning Table" instructions.

Miter Gauge

The miter gauge needs to be calibrated to the blade when it is first mounted in the miter slot.

To calibrate the miter gauge:

1. Use a machinist's square with one edge against the face of the miter gauge and the other against the blade face as shown in **Figure 36**.

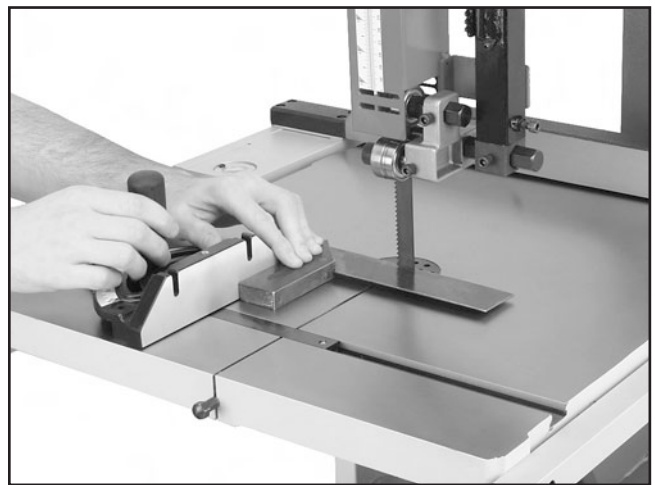

Figure 36. Squaring miter gauge to blade.

2. Loosen the lock knob on the miter gauge and adjust it flush with the edge of the square.
3. Tighten the lock knob, and verify the setting.

Note: Sometimes the tightening procedure can affect the adjustment.

4. Loosen the screw that secures the angle pointer and adjust the pointer to the 0° mark on the scale.
5. Retighten the screw that secures the angle pointer.



SECTION 4: OPERATIONS

Operation Safety

!WARNING

Damage to your eyes, lungs, and ears could result from using this machine without proper protective gear. Always wear safety glasses, a respirator, and hearing protection when operating this machine.

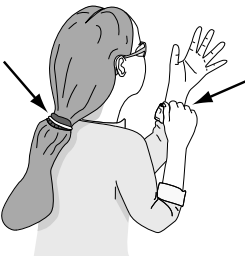
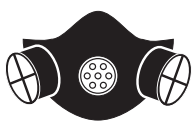

!WARNING

Loose hair and clothing could get caught in machinery and cause serious personal injury. Keep loose clothing and long hair away from moving machinery.

NOTICE

If you have never used this type of machine or equipment before, WE STRONGLY RECOMMEND that you read books, trade magazines, or get formal training before beginning any projects. Regardless of the content in this section, Grizzly Industrial will not be held liable for accidents caused by lack of training.

Overview

The bandsaw is one of the most versatile wood cutting tools in the shop. It is capable of performing many different cutting functions including:

Straight Cuts

- Mitters
- Angles
- Compound Angles
- Resawing
- Ripping
- Crosscutting

Irregular Cuts

- Simple and Complex Curves
- Duplicate Parts
- Circles
- Beveled Curves

A properly adjusted and tuned bandsaw can be safer to operate than most other saws and performs many functions with ease and accuracy.

Basic Cutting Tips

Here are some basic tips to follow when operating the bandsaw:

- Replace, sharpen, and clean blades as necessary and make adjustments periodically to keep the saw always running in top condition.
- Use light and even pressure while cutting. Light contact with the blade will permit easier line following and prevent undue friction.
- Avoid trying to turn tight corners because this will twist the blade. Remember, you must saw around corners.
- Misuse of the saw or using incorrect techniques is unsafe and results in frustration and poor cuts. Remember—the blade does the cutting with the operator's guidance.



START/STOP Switch

The START/STOP switch on the Model G0513X/G0514X/G0514X3 is located on the column for easy access (**Figures 37 & 38**). Immediately turn the machine **OFF** if there becomes a safety hazard.



Figure 37. G0513X START/STOP switch.



Figure 38. G0514X/G0514X3 START/STOP switch.

The Model G0514X/G0514X3 features a switch disabling lock to prevent unauthorized starting of the machine. To disable the switch, turn the key to "0". To enable the switch, turn the key to "1".

Guide Post

The guide post, shown in **Figure 39**, connects the upper blade guide assembly to the bandsaw. The guidepost allows the blade guide assembly to move up or down via a rack and pinion. In order to cut accurately, the blade guide assembly must be no more than 1" from the top of the workpiece at all times—this positioning provides the best support for the blade.

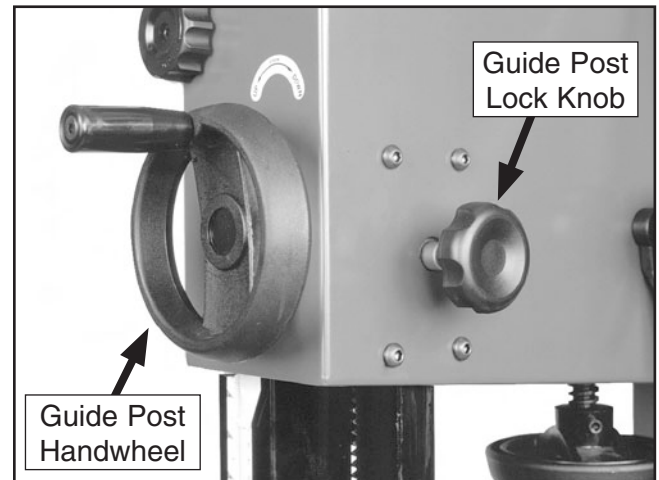

Figure 39. Guide post controls.

To adjust guide post:

1. Make sure that the blade tension, blade tracking, support bearing, and blade guides are adjusted correctly.
2. Loosen the guide post lock knob shown in **Figure 39**.
3. Turn the guide post handwheel to raise or lower the guide post until the upper blade guide assembly is within 1" from the top of the workpiece.
4. Lock the guide post in place with the lock knob.



Fine Tune Tracking

NOTICE

Adjusting the final blade tracking setting requires the machine to be turned **ON**.

To fine tune the tracking:

1. Close the wheel covers and turn the bandsaw **ON**.
2. Observe the blade tracking path through the clear window on the right edge of the bandsaw as shown in **Figure 40**.

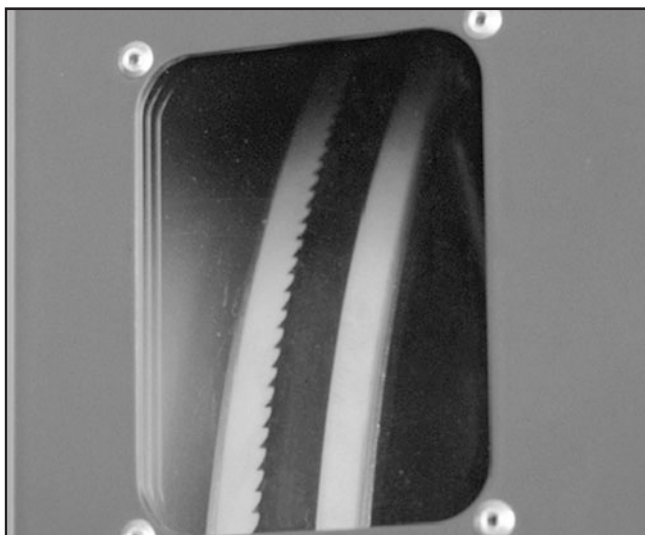

Figure 40. Blade tracking window.

3. Using the tracking controls (**Page 23, Figure 18**), adjust the blade so it tracks on the center of the wheel.
4. Tighten the tracking lock so the knob cannot move.

Blade Lead

Bandsaw blades commonly wander off the cut line when sawing, as shown in **Figure 41**. This is called blade lead. Blade lead is commonly caused by too fast of a feed rate, a dull or abused blade, or improper tension. If your blade is sharp/undamaged and you still have blade lead, perform the following instructions.



Figure 41. Blade leading away from line of cut.

To correct blade lead:

1. Use less pressure when feeding the workpiece through the cut.
2. Check that the miter slot or fence is parallel to the blade line, and correct if necessary.
3. Check for proper blade tension. If the blade tension is correct and it is not convenient to replace the blade, compensate for lead by skewing the fence or adjusting the table.

To skew your fence:

1. Cut a piece of scrap wood approximately $\frac{3}{4}$ " thick x 3" wide x 17" long. On a wide face of the board, draw a straight line parallel to the long edge.
2. Cut halfway through the board on the line by pushing it into the blade. Turn the bandsaw **OFF** and wait for the blade to stop.



3. Clamp the board to the bandsaw table without moving it. Now slide the fence over to the board so it barely touches one end of the board.
4. Loosen the four cap screws on top of the fence.
5. Skew the fence so it is parallel to the edge of the scrap piece. You may need to re-adjust the fence locking mechanisms to gain maximum adjustment.
6. While maintaining the skew, tighten the cap screws.

To shift the table:

1. On a scrap piece of wood, mark a line that is perpendicular to the front edge.
2. Cut halfway through the board on the line by pushing it into the blade.
3. Turn the bandsaw **OFF** and wait for the blade to stop.
4. Loosen the table mounting bolts. Shift the table to compensate for the blade lead, then retighten the table bolts.
5. Repeat **Steps 1–4** until the blade cuts straight.

Table Tilt

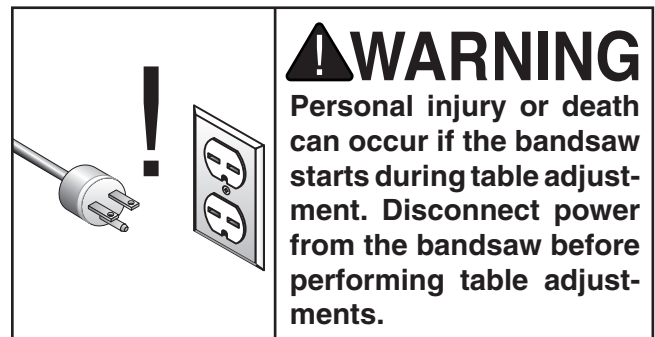

The bandsaw table will tilt 5° left and 45° right to provide a wide range of cutting options. Remove the positive stop bolt to tilt the table to the left.

To tilt the table:

1. DISCONNECT BANDSAW FROM POWER!
2. Loosen the lock handle on the table trunnion shown in **Figure 42**.

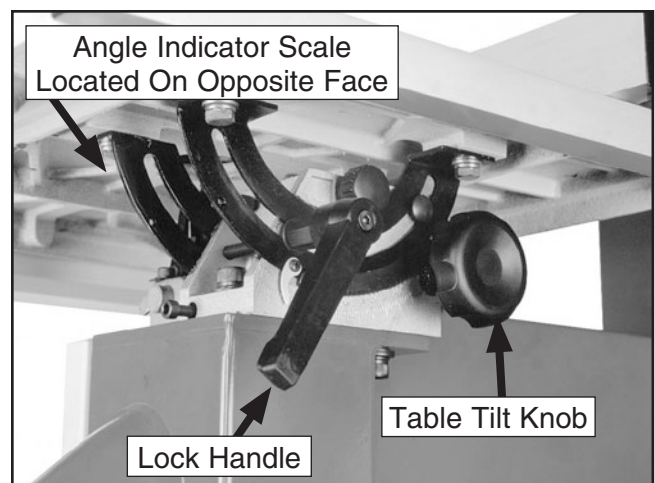

Figure 42. Table tilt controls.

3. Turn the table tilt knob to position the table to the desired angle of tilt. Refer to the angle gauge on the front table trunnion for the tilting angle.
4. Retighten the lock handle to secure the table.



Ripping

Ripping is the process of cutting with the grain of the wood stock. For plywood and other processed wood, ripping simply means cutting down the length of the workpiece.

To make a rip cut:

1. Adjust the fence to match the width of the cut on your workpiece and lock the fence in place.
2. Adjust the blade guide assembly to the correct height.
3. After all safety precautions have been met, turn the bandsaw **ON**. Slowly feed the workpiece into the blade and continue with the cut until the blade is completely through the workpiece. **Figure 43** shows a typical ripping operation. **Note:** *If you are cutting narrow pieces, use a push stick to protect your fingers.*



Figure 43. Ripping with a push stick.

⚠WARNING

NEVER place fingers or hands in the line of cut. In the event that something unexpected happens, your hands or fingers may be pulled into the blade. **ALWAYS** use a push stick when ripping narrow pieces. Failure to follow these warnings may result in serious personal injury!

Crosscutting

Crosscutting is the process of cutting across the grain of wood. For plywood and other processed wood, crosscutting simply means cutting across the width of the material.

To make a 90° crosscut:

1. Mark the workpiece on the edge where you want to begin the cut.
2. Adjust the blade guide assembly to the correct height and make sure the miter gauge is set to 90°.
3. Move the fence out of the way. Place the workpiece evenly against the miter gauge.
4. Hold the workpiece against the miter gauge and line up the mark with the blade.
5. After all safety precautions have been met, turn the bandsaw **ON**. Slowly feed the workpiece into the blade and continue the cut until the blade is all the way through the workpiece. **Figure 44** shows a typical crosscutting operation.



Figure 44. Crosscutting with miter gauge.



Resawing

Resawing (**Figure 45**) is the process of cutting a board into two or more thinner boards. The maximum board width that can be resawn is limited by the maximum cutting height of the bandsaw.

One of the most important considerations when resawing is blade selection. Generally, the wider blade, the better. In most applications, a hook or a skip tooth style will be desirable. Choose blades with fewer teeth-per-inch (from 3 to 6), because they offer larger gullet capacities for clearing sawdust, reducing heat buildup and reducing strain on the motor.



Figure 45. Resawing lumber.

⚠WARNING

When resawing thin pieces, a wandering blade (blad lead) can tear through the surface of the workpiece, exposing your hands to the blade teeth. Always use push blocks when resawing and keep your hands clear of the blade.

To resaw a workpiece:

1. Verify that the bandsaw is setup properly and that the table is perpendicular to the blade.
2. Use the widest blade your bandsaw will accept. **Note:** *The blade must also be sharp and clean.*
3. Install the resaw fence and set it to the desired width of cut and lock it in place.

NOTICE

The scale on the front rail will NOT be accurate when using the resaw fence.

4. Support the ends of the board if necessary.
5. Turn the bandsaw **ON**.
6. Using push paddles and a push stick, keep pressure against the fence and table, and slowly feed the workpiece into the moving blade until the blade is completely through the workpiece (see **Figure 45**).



Cutting Curves

When cutting curves, simultaneously feed and turn the stock carefully so that the blade follows the layout line without twisting. If a curve is so abrupt that it is necessary to repeatedly back up and cut a new kerf, use either a narrower blade or a blade with more TPI (teeth per inch), or make more relief cuts.

Always make short cuts first, then proceed to the longer cuts. Relief cuts will also reduce the chance that the blade will be pinched or twisted. Relief cuts are cuts made through the waste portion of the workpiece and are stopped at the layout line. As you cut along the layout line, waste wood is released from the workpiece, alleviating any pressure on the back of the blade. Relief cuts also make backing the workpiece out easier, if needed.

NOTICE

The list below displays blade widths and the corresponding minimum radii for those blade widths.

Width	Radius
1/8"	1/8"
3/16"	3/8"
1/4"	5/8"
3/8"	1 1/4"
1/2"	2 1/2"
5/8"	3 3/4"
3/4"	5 1/2"

Stacked Cuts

One of the benefits of a bandsaw is its ability to cut multiple copies of a particular shape by stacking a number of workpieces together. Before making stacked cuts, ensure that both the table and the blade are properly adjusted to 90°. Otherwise, any error will be compounded.

To complete a stacked cut:

1. Align your pieces from top to bottom to ensure that each piece has adequate scrap to provide a clean, unhampered cut.
2. Secure all the pieces together in a manner that will not interfere with the cutting. Hot glue on the edges works well, as do brad nails through the waste portion. (Be careful not to cut into the brads or you may break the blade!)
3. On the face of the top piece, lay out the shape you intend to cut.
4. Make relief cuts perpendicular to the outline of your intended shape in areas where changes in blade direction could strain the woodgrain or cause the blade kerf to bind.
5. Cut the stack of pieces as though you were cutting a single piece. Follow your layout line with the blade kerf on the waste side of your line as shown in **Figure 46**.



Figure 46. Typical stacked cut.



Blade Speed

The blade speed can be adjusted to 1700 or 3500 FPM. Speed adjustments are made by moving the V-belt position on the motor and wheel pulleys.

Most woodcutting can be performed successfully at the higher blade speeds. Slower blade speeds generally produce better results when cutting hardwoods, intricate curves, or when an exceptionally smooth cut is desired.

To adjust the blade speed:

1. DISCONNECT BANDSAW FROM POWER!
2. Loosen the motor mount cap screws shown in **Figure 47** and rotate the motor to loosen the V-belt.



Figure 47. Motor mount cap screws.

3. Refer to **Figure 48** to locate the correct V-belt position for the desired blade speed.

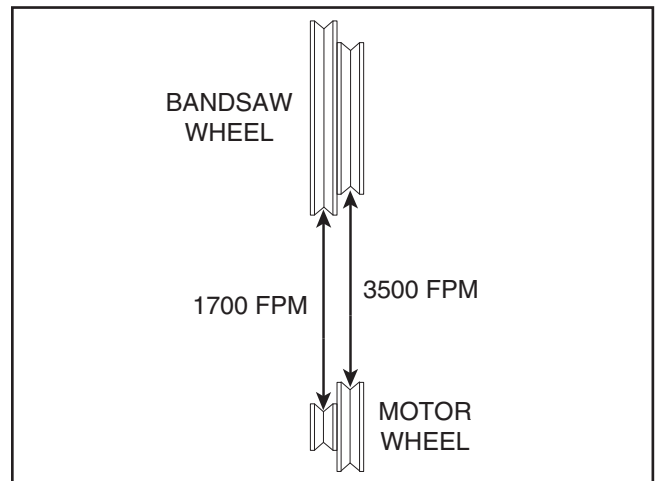

Figure 48. V-belt speeds.

4. Move the V-belt to the desired pulley.
5. Rotate the motor to tension the V-belt, then tighten the motor mount cap screws.
6. Check the V-belt tension. When tensioned correctly, the V-belt can be deflected approximately $\frac{3}{4}$ " (see **Figure 49**).

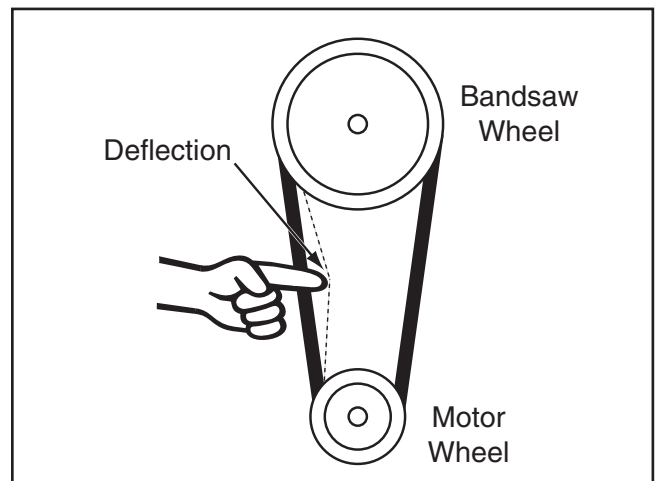

Figure 49. V-belt deflection.

Blade Information

Selecting the right blade requires a knowledge of the various blade characteristics to match the blade with the particular cutting operation.

Blade Length

Measured by the circumference, blade lengths are usually unique to the brand of your bandsaw and the distance between wheels. The Model G0513X is designed for blades that are 131½" long and the Model G0514X/G0514X3 is designed for blades that are 143" long. Refer to **Page 43** for blade replacements.

Blade Width

Measured from the back of the blade to the tip of the blade tooth (the widest point), blade width is often the first consideration given to blade selection. Blade width dictates the largest and smallest curve that can be cut, as well as how accurately it can cut a straight line.

The Model G0513X can use blades from ⅛" to 1" in width. The Model G0514X/G0514X3 can use blades from ⅛" to 1¼" in width. Always pick the size of blade that best suits your application.

- **Curve Cutting:** Use the chart in **Figure 50** to determine the correct blade for curve cutting. Determine the smallest radius curve that will be cut on your workpiece and use the corresponding blade width.

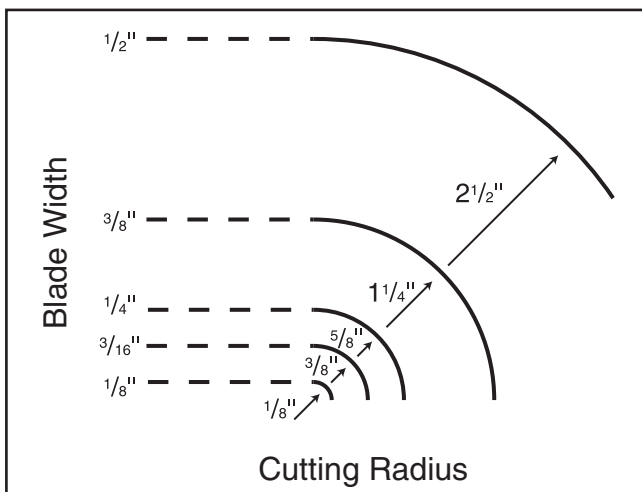

Figure 50. Blade width radii.

- **Straight Cutting:** Use the largest width blade that you own. Narrow blades can cut tight curves (a small radius) but are not very good at cutting straight lines because they naturally wander (blade lead). However, larger blades are much better at cutting straight lines, but function poorly at cutting small curves because of their size.

Tooth Style

When selecting blades, another option to consider is the shape, gullet size, teeth set and teeth angle—otherwise known as “Tooth Style.”

Figure 51 shows the three main categories of tooth style:

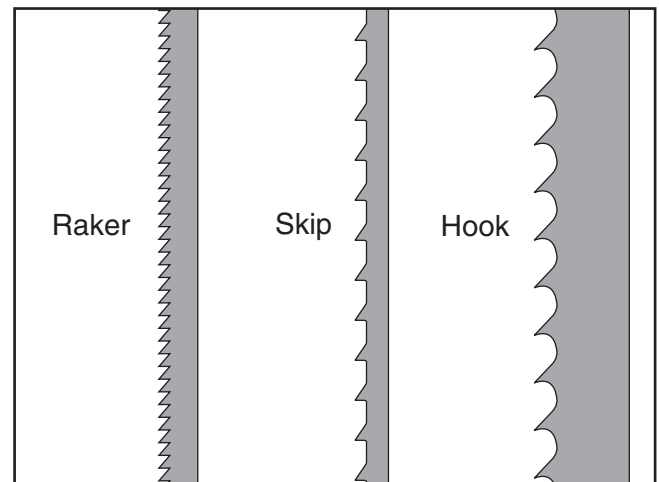

Figure 51. Raker, Skip & Hook tooth styles.

- **Raker:** This style is considered to be the standard because the tooth size and shape are the same as the tooth gullet. The teeth on Raker blades usually are very numerous, have no angle, and produce cuts by scraping the material; these characteristics result in very smooth cuts, but do not cut fast and generate more heat while cutting.
- **Skip:** This style is similar to a raker blade that is missing every other tooth. Because of the design, skip toothed blades have a much larger gullet than raker blades, and therefore, cut faster and generate more heat. However, these blades also leave a rougher cut than raker blades.



- **Hook:** The teeth on this style have a positive angle (downward) which makes them dig into the material, and the gullets are usually rounded for easier waste removal. These blades are excellent for the tough demands of resawing and ripping thick material.

Tooth Pitch

Usually measured as TPI (teeth per inch), tooth pitch determines the size of the teeth. More teeth per inch (fine pitch) will cut slower, but smoother; while fewer teeth per inch (coarse pitch) will cut rougher, but faster. As a general rule, choose blades that will have at least three teeth in the material at all times. Use fine pitched blades on harder woods and coarse pitched blades on softer woods.

Blade Care

A bandsaw blade is a delicate piece of steel that is subjected to tremendous strain. You can obtain longer use from a bandsaw blade if you give it fair treatment and always use the appropriate feed rate for your operation.

Be sure to select blades with the proper width, style, and pitch for each application. The wrong choice of blades will often produce unnecessary heat which will shorten the life of your blade.

A clean blade will perform much better than a dirty blade. Dirty or gummed up blades pass through the cutting material with much more resistance than clean blades. This extra resistance also causes unnecessary heat.

Blade Breakage

Many conditions may cause a bandsaw blade to break. Blade breakage is unavoidable, in some cases, since it is the natural result of the peculiar stresses that bandsaw blades are subjected to. Blade breakage is also due to avoidable circumstances. Avoidable breakage is most often the result of poor care or judgement on the part of the operator when mounting or adjusting the blade or support guides.

The most common causes of blade breakage are:

- Faulty alignment and adjustment of the guides.
- Forcing or twisting a wide blade around a curve of short radius.
- Feeding the workpiece into the blade too fast.
- Tooth dullness or absence of sufficient set.
- Incorrect tension.
- Top blade guide assembly set too high above the workpiece.
- Using a blade with a lumpy or improperly finished braze or weld.
- Continuously running the bandsaw when not in use.



Blade Changes

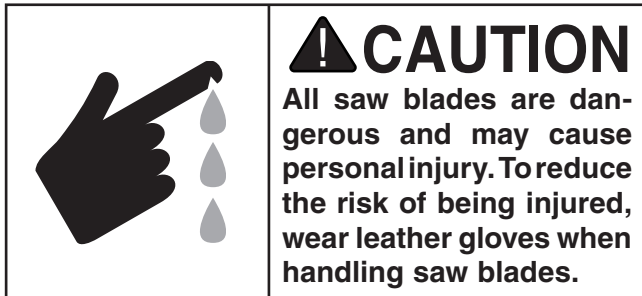
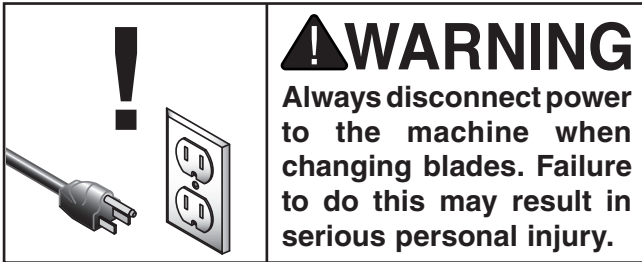

To remove a blade:

1. DISCONNECT BANDSAW FROM POWER!
2. Release the blade tension by turning the blade tension quick release lever to the left.
3. Remove the table insert and the table pin. Adjust the upper and lower guide bearings as far away as possible from the blade.
4. Open the upper and lower wheel covers, and with gloved hands, slide the blade off of both wheels.
5. Rotate the blade 90° and slide it through the slot in the table.

To replace a blade:

1. Slide the blade through the table slot, ensuring that the teeth are pointing down toward the table. **Note:** *If the teeth will not point downward in any orientation, the blade is inside-out. Put on heavy gloves, remove the blade, and twist it right side-out.*
2. Slip the blade through the guides, and mount it on the upper and lower wheels (**Figure 52**).

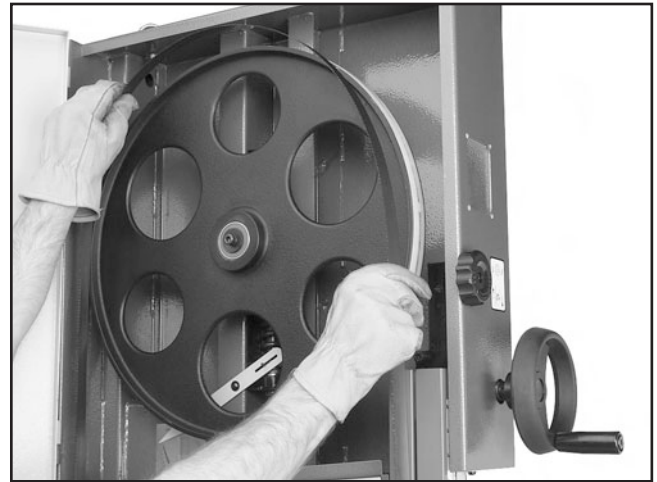

Figure 52. Placing blade on the wheels.

3. Tighten the blade tension lever.
4. Apply tension to the blade by turning the tension control knob. Rotate the upper wheel slowly by hand as tension is applied to allow the blade to center itself on the wheel. Adjust tracking if needed.
5. Adjust tension as described **Page 27**.
6. Adjust the upper/lower guide bearings and the support bearings.
7. Close the wheel covers.
8. Replace the table insert and table pin, being sure not to use excessive force when inserting the table pin.



SECTION 5: ACCESSORIES

Replacement Blades

These replacement blades are milled for exact tooth set and are made with high quality tool steel.

131½" Carbon Steel Replacement Blades for the Model G0513X

MODEL	WIDTH	TPI
H4803	1/8"	14 RAKER
H4804	1/4"	6 HOOK
H4805	1/4"	18 RAKER
H4806	3/8"	10 RAKER
H4807	1/2"	6 HOOK
H4808	1/2"	10 RAKER
H4809	3/4"	3 HOOK
H4810	1"	6 HOOK
H4811	1"	2 HOOK

131½" Carbide Tipped Replacement Blades for the Model G0513X.

MODEL	WIDTH	TPI
H4897	3/8"	3-4 VP
H4898	1/2"	3
H4899	3/4"	3
H4900	1"	2-3 VP
H4901	1"	3-4 VP

143" Carbon Steel Replacement Blades for the Model G0514X and Model G0514X3.

MODEL	WIDTH	TPI
H4826	1/8"	14 RAKER
H4827	1/4"	6 HOOK
H4828	1/4"	18 RAKER
H4829	3/8"	10 RAKER
H4830	1/2"	6 HOOK
H4831	1/2"	10 RAKER
H4832	3/4"	3 HOOK
H4833	1"	6 HOOK
H4834	1"	2 HOOK
H4835	1-1/4"	1.3 HOOK

143" Carbon Steel Replacement Blades for the Model G0514X and Model G0514X3.

MODEL	WIDTH	TPI
H4907	3/8"	3-4 VP
H4908	1/2"	3
H4909	3/4"	3
H4910	1"	2-3 VP
H4911	1"	3-4 VP
H4912	1-1/4"	2-3 VP
H4913	1-1/4"	3-4 VP

Call 1-800-523-4777 To Order



- G7984—Face Shield**
- H1298—Dust Sealed Safety Glasses**
- H1300—UV Blocking, Clear Safety Glasses**
- H2347—Uvex® Spitfire Safety Glasses**
- H0736—Shop Fox® Safety Glasses**

Safety Glasses are essential to every shop. If you already have a pair, buy extras for visitors or employees. You can't be too careful when it comes to shop safety!



Figure 53. Our most popular safety glasses.

- H1302—Standard Earmuffs**
 - H4979—Deluxe Twin Cup Hearing Protector**
 - H4977—Work-Tunes Radio Headset Earmuffs**
- Protect yourself comfortably with a pair of cushioned earmuffs. Especially important if you or employees operate for hours at a time.



Figure 54. Our most popular earmuffs.

- H2499—Small Half-Mask Respirator**
- H3631—Medium Half-Mask Respirator**
- H3632—Large Half-Mask Respirator**
- H3635—Disposable Cartridge Filter Pair P100**

Wood dust is now considered a known carcinogen and has been linked to nasal cancer and severe respiratory illnesses. If you work around dust everyday, a half-mask respirator can be a lifesaver. Also compatible with safety glasses!



Figure 55. Half-mask respirator and disposable cartridge filters.

- G5562—SLIPIT® 1 Qt. Gel**
- G5563—SLIPIT® 12 oz Spray**
- G2871—Boeshield® T-9 12 oz Spray**
- G2870—Boeshield® T-9 4 oz Spray**
- H3788—G96® Gun Treatment 12 oz Spray**
- H3789—G96® Gun Treatment 4.5 oz Spray**

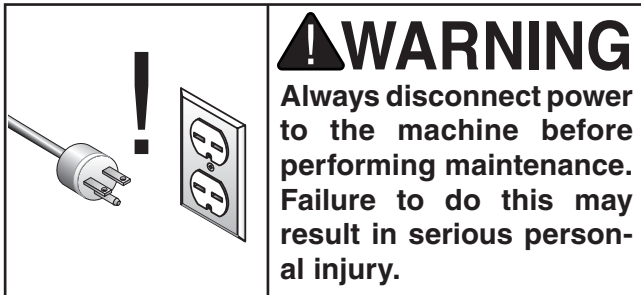

Figure 56. Recommended products for protecting unpainted cast iron/steel on machinery.

Call 1-800-523-4777 To Order



SECTION 6: MAINTENANCE



Schedule

For optimum performance from your machine, follow this maintenance schedule and refer to any specific instructions given in this section.

Daily Check:

- Loose mounting bolts.
- Damaged saw blade.
- Worn or damaged wires.
- Any other unsafe condition.

Monthly Check:

- V-belt tension, damage, or wear.
- Clean/vacuum dust buildup from inside cabinet and off motor.

Cleaning

Cleaning your bandsaw is relatively easy. Vacuum excess wood chips and sawdust, and wipe off the remaining dust with a dry cloth. If any resin has built up, use a resin dissolving cleaner to remove it. Treat all unpainted cast iron and steel with a non-staining lubricant after cleaning.

Unpainted Cast Iron

Protect the unpainted cast iron surfaces on the table by wiping the table clean after every use—this ensures moisture from wood dust does not remain on bare metal surfaces.

Keep tables rust-free with regular applications of products like G96® Gun Treatment, SLIPIT®, or Boeshield® T-9 (see **SECTION 5: ACCESSORIES** on **Page 43** for more details).

Lubrication

Sealed and pre-lubricated ball bearings require no lubrication for the life of the bearings. All bearings are standard sizes, and replacements can be purchased from our parts department or a bearing supply store.

For adjustment controls, an occasional “shot” of light oil is just about all that is necessary. Wipe off any sawdust with a clean cloth, towel, or dry paint brush, and spray on the lubricant. Do not get oil on the pulleys or V-belt because it could cause belt deterioration and slipping.

Wheel Brush

The bandsaw is equipped with a lower wheel brush. The brush should be checked daily and cleaned when it becomes dirty. There is an adjustment bracket that allows the brush to be adjusted for bristle wear. Refer to **Adjusting Wheel Brush** on **Page 50** for adjustment details.



SECTION 7: SERVICE

This section is provided for your convenience—it is not a substitute for the Grizzly Service Department. If you need help troubleshooting, you need replacement parts, or you are unsure of how to perform the procedures in this section, then feel free to call our Technical Support at (570) 546-9663.

Troubleshooting

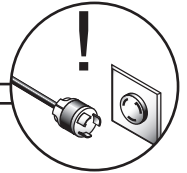

Motor & Electrical

Symptom	Possible Cause	Possible Solution
Machine does not start or a breaker trips.	<ol style="list-style-type: none"> 1. Plug/receptacle is at fault or wired incorrectly. 2. Motor connection wired incorrectly. 3. Power supply is at fault/switched OFF. 4. Motor ON/OFF switch is at fault. 5. Centrifugal switch is at fault. 6. Wiring is open/has high resistance. 7. Start capacitor is at fault. 8. Motor is at fault. 	<ol style="list-style-type: none"> 1. Test for good contact or correct the wiring. 2. Correct motor wiring connections (Page 54). 3. Ensure hot lines have correct voltage on all legs and main power supply is switched ON. 4. Replace faulty ON/OFF switch. 5. Adjust/replace the centrifugal switch if available. 6. Check for broken wires or corroded/disconnected connections, and repair/replace as necessary. 7. Test/replace if faulty. 8. Repair/replace.
Machine stalls or is underpowered.	<ol style="list-style-type: none"> 1. Wrong workpiece material (wood). 2. Processing speed too fast for task. 3. V-belt slipping. 4. Blade is slipping on wheels. 5. Low power supply voltage. 6. Run capacitor is at fault. 7. Plug/receptacle is at fault. 8. Motor connection is wired incorrectly. 9. Motor bearings are at fault. 10. Motor has overheated. 11. Motor is at fault. 12. Centrifugal switch is at fault. 	<ol style="list-style-type: none"> 1. Use wood with correct moisture content, without glues, and little pitch/resins. 2. Decrease processing speed. See Basic Cutting Tips on Page 32. 3. Replace bad V-belt, align pulleys, and re-tension (Page 49). 4. Adjust blade tracking and tension to factory specifications. See Page 22 or 27. 5. Ensure all hot lines have correct voltage on all legs. 6. Repair/replace. 7. Test for good contacts and correct wiring. 8. Correct motor wiring connections (Page 54). 9. Test by rotating shaft; rotational grinding/loose shaft requires bearing replacement. 10. Clean off motor, let cool, and reduce workload. 11. Repair/replace. 12. Adjust/replace centrifugal switch if available.

WARNING

Disconnect power to the machine when performing any troubleshooting. Failure to do this may result in serious personal injury.



Symptom	Possible Cause	Possible Solution
Machine has vibration or noisy operation when running.	<ol style="list-style-type: none"> 1. Blade weld hits guides or teeth are broken. 2. Bent or worn out blade. 3. Motor or component is loose. 4. V-belt worn or loose. 5. Motor fan is rubbing on fan cover. 6. Pulley is loose. 7. Machine is incorrectly mounted or sits unevenly on floor. 8. Motor bearings are at fault. 9. Worn arbor bearings. 10. Wheels not coplanar/aligned correctly. 11. Tires incorrectly installed on wheels. 12. Wheels out of balance. 	<ol style="list-style-type: none"> 1. Replace blade (Page 42). 2. Replace blade (Page 42). 3. Inspect/replace stripped or damaged bolts/nuts, and re-tighten with thread locking fluid. 4. Inspect/replace belts with matched set (Page 49). 5. Replace dented fan cover and loose/damaged fan. 6. Realign/replace shaft, pulley, setscrew, and key as required. 7. Adjust the feet on the bottom of the stand; relocate machine. 8. Test by rotating shaft — rotational grinding/loose shaft requires bearing replacement. 9. Check/replace arbor bearings. 10. Adjust wheel alignment to coplaner (Page 51). 11. Re-install tires on wheels. 12. Replace wheels.

Cutting Operations



Symptom	Possible Cause	Possible Solution
Machine slows when operating.	<ol style="list-style-type: none"> 1. Feeding workpiece too fast. 2. Blade is dull. 	<ol style="list-style-type: none"> 1. Reduce feed rate. See Basic Cutting Tips on Page 32. 2. Replace blade (Page 42).
Ticking sound when the saw is running.	<ol style="list-style-type: none"> 1. Blade weld contacting support bearing. 2. Blade weld may be failing. 	<ol style="list-style-type: none"> 1. Use file or stone to smooth and round the back of the blade. 2. Inspect and replace blade if necessary (Page 42).
Blade contacting table insert.	<ol style="list-style-type: none"> 1. Excessive side pressure when cutting. 2. Table improperly adjusted. 	<ol style="list-style-type: none"> 1. Reduce side pressure. 2. Adjust table (Page 30).
Vibration when cutting.	<ol style="list-style-type: none"> 1. Loose or damaged blade. 	<ol style="list-style-type: none"> 1. Tighten or replace blade. See Page 27 or 42.
Burn marks on the edge of the cut.	<ol style="list-style-type: none"> 1. Too much side pressure when feeding workpiece. 2. Blade too wide for size of radius being cut. 	<ol style="list-style-type: none"> 1. Feed workpiece straight into the blade. See Basic Cutting Tips on Page 32. 2. Install a smaller width blade/increase blade tension. See Page 27 or 42.
Rough or poor quality cuts.	<ol style="list-style-type: none"> 1. Feeding workpiece too fast. 	<ol style="list-style-type: none"> 1. Reduce feed rate. See Basic Cutting Tips on Page 32.
Sawdust buildup inside cabinet.	<ol style="list-style-type: none"> 1. Clogged dust port. 2. Low CFM (airflow) from dust collection system. 	<ol style="list-style-type: none"> 1. Clean out dust port. 2. Three options: <ul style="list-style-type: none"> —Check dust lines for leaks or clogs. —Move dust collector closer to saw. —Install a stronger dust collector.
Blade wanders or won't follow line of cut.	<ol style="list-style-type: none"> 1. Blade lead. 	<ol style="list-style-type: none"> 1. Refer to Blade Lead on Page 34.



Checking V-Belt

To ensure optimum power transmission from the motor to the blade, the V-belt must be in good condition and operate under proper tension. The belt should be checked for cracks, fraying, and wear. Belt tension should be checked at least every 3 months—more often if the bandsaw is used daily.

To check the V-belt:

1. DISCONNECT BANDSAW FROM POWER!
2. Open the lower wheel cover.
3. Note the condition of the V-belt. If the V-belt is cracked, frayed, or glazed; it should be replaced as soon as convenient.
4. Push the center of the V-belt. Note the amount of deflection (**Figure 57**). If deflection is more than $\frac{3}{4}$ ", tighten the V-belt.

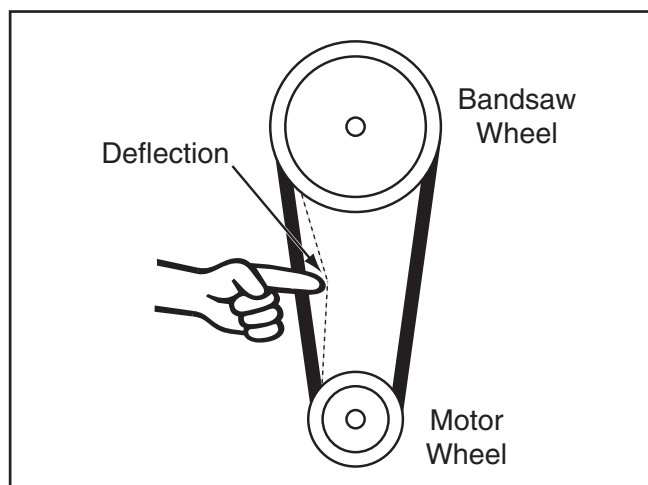

Figure 57. V-belt deflection.

Tensioning V-Belt

Tools Needed:	Qty
Hex Wrench 6mm.....	1

To tension the V-belt:

1. DISCONNECT BANDSAW FROM POWER!
2. Open the lower wheel cover.
3. Loosen the motor mount screws shown in **Figure 58**.

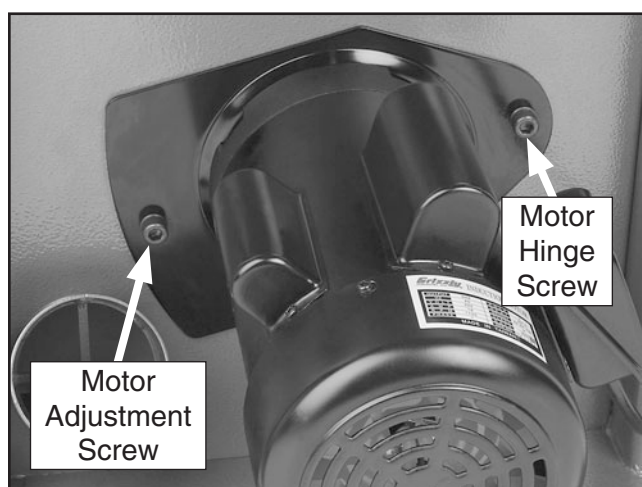

Figure 58. Motor mount screws.

4. Rotate the motor to tension the V-belt, then tighten the motor adjustment screw.
5. Push the center of the V-belt. If deflection is approximately $\frac{3}{4}$ " with moderate pressure from your thumb or finger, then the tension is correct. If the deflection is more than $\frac{3}{4}$ ", repeat **Steps 3 & 4**.
6. When the V-belt tension is correct, tighten the motor hinge screw and close the lower wheel cover.



Replacing V-Belt

Tools Needed:	QTY
Hex Wrench 6mm.....	1
Wrench 13mm	1

To replace the V-belt:

1. DISCONNECT BANDSAW FROM POWER!
2. Open both wheel covers, and remove the blade.
3. Loosen the motor mount screws shown in **Figure 58**.
4. Unthread the wheel mount bolt shown in **Figure 59** and slide the lower wheel off of the bearing shaft.

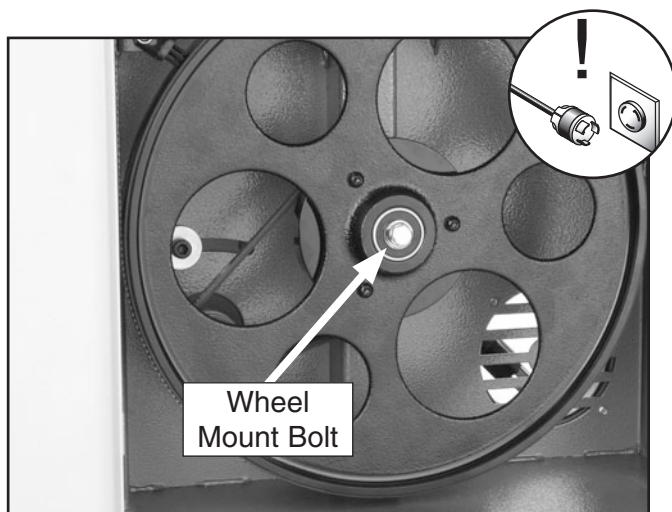

Figure 59. Wheel mount bolt.

5. Rotate the motor to release the tension on the V-belt and pull it off of the motor pulley.
6. Slip the old V-belt off of the wheel pulley and install the new V-belt in its place.
7. Install the lower wheel back onto the bearing shaft and replace/tighten the wheel mount bolt.
8. Rotate the motor to tension the V-belt, then tighten the motor adjustment screw.
9. Check the V-belt tension and adjust if necessary as described in the **Tensioning V-Belt** instructions.
10. When the V-belt tension is correct, tighten the motor hinge bolt and close the lower wheel cover.



Adjusting Tension Lever

The tension lever has an adjustment screw that allows you to adjust how much tension is released when the lever is used.

Tools Needed:	QTY
Hex Wrench 6mm.....	1
Hex Wrench 5mm.....	1

To adjust the tension lever:

1. DISCONNECT BANDSAW FROM POWER!
2. Loosen the tension lever and remove the blade.
3. Remove the upper wheel by taking out the cap screw at the center of the wheel.
4. Move the tension lever to the tightened position.
5. Turn the adjustment screw shown in **Figure 60** until the gap between the screw and the wheel shaft hinge is $\frac{1}{16}$ " - $\frac{3}{16}$ ".

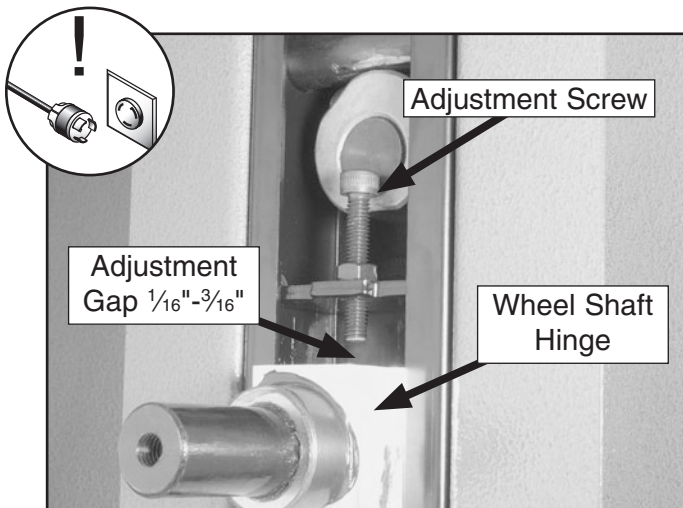

Figure 60. Tension lever adjustment components.

6. Reassemble the removed components and tension and track the blade as normal.

Adjusting Wheel Brush

The lower wheel compartment contains the wheel brush shown in **Figure 61**. This brush is designed to sweep sawdust off the wheel tire as the bandsaw is operating. In order to work properly the brush must be making contact with the wheel.

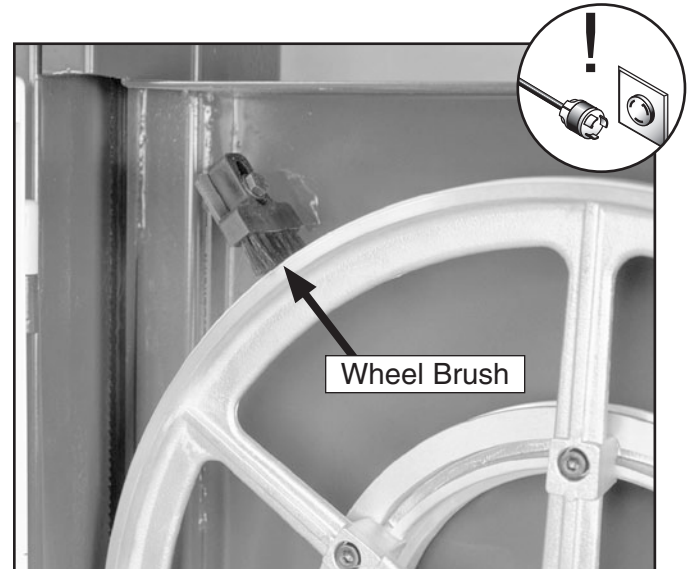

Figure 61. The wheel brush.

Tools Needed:	QTY
Wrench/Socket 10mm	2

To adjust the wheel brush:

1. DISCONNECT BANDSAW FROM POWER!
2. Open the lower wheel cover.
3. Loosen the bolt/nut that secures the wheel brush in place.
4. Adjust the wheel brush so it makes good contact with the wheel.
5. Tighten the bolt/nut to secure the wheel brush in place.



Wheel Alignment

Components and Hardware Needed:	Qty
60" Long 2x4	1

Tools Needed:

Wrench 13mm	1
Tape Measure	1
Coplanarity Gauge (see Figure 62)	1

Wheel alignment is one of the most critical factors for optimal performance from your bandsaw.

Heat, vibration, wandering, blade wear, tire wear and overall bandsaw wear are considerably decreased when the wheels are properly aligned or "coplanar."

Coplanar wheels automatically track the blade by balancing it on the crown of the wheel. This is known as coplanar tracking.

To check if your wheels are coplanar:

1. Make the "Coplanarity Gauge" shown in **Figure 62**. **Note:** For best results, straighten the 2x4 with a jointer before cutting.
2. Remove the fence and table, then open both wheel covers.
3. Make sure the guide blocks and rear support bearings are away from the blade, then tighten your blade to the tension that it will be used during operation.
4. Place your coplanarity gauge up against both wheels in the positions shown in **Figure 63**.

Continued on next page →

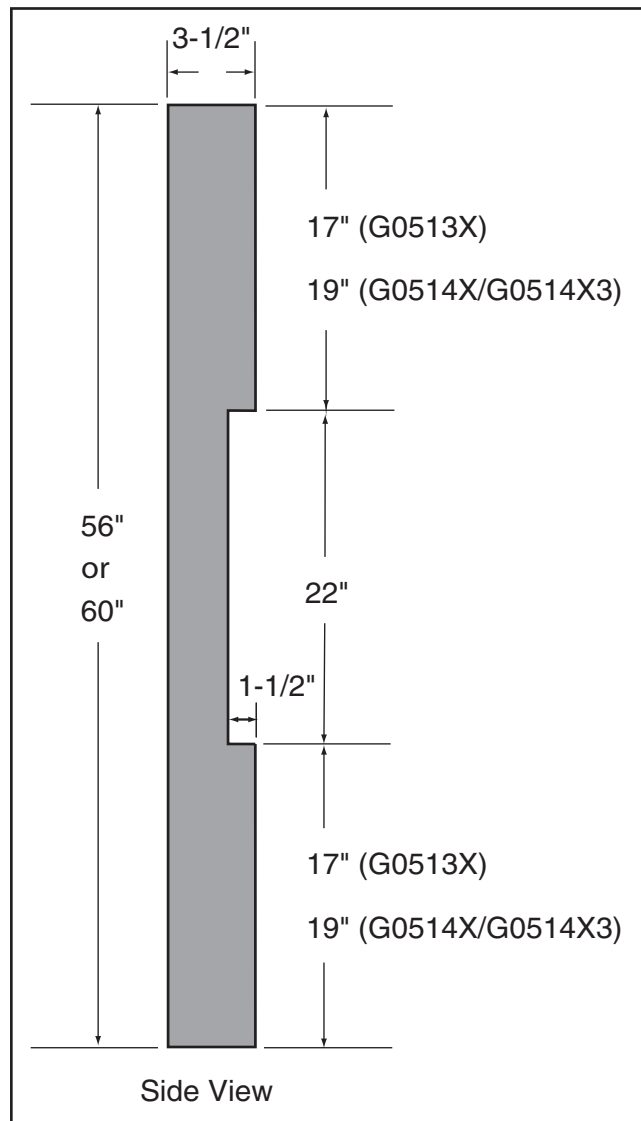

Figure 62. Dimensions of coplanarity gauge.

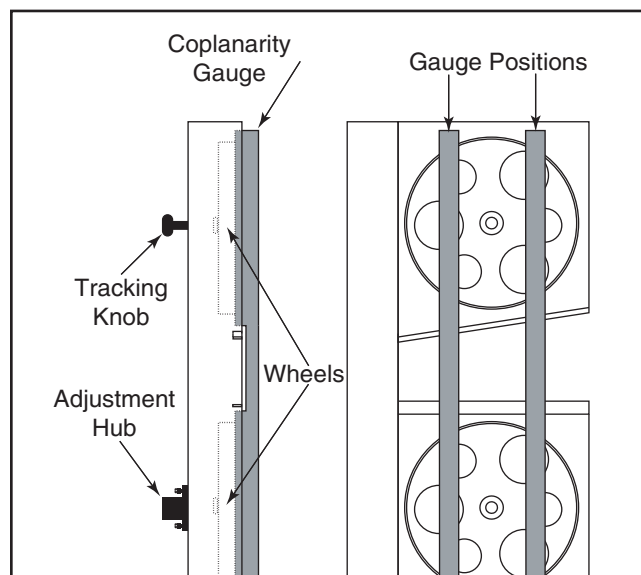

Figure 63. Checking for coplanarity.



5. Adjust the tracking knob to get both wheels parallel. If the wheels won't go parallel to each other, then move the lower wheel at the adjustment hub (**Figure 64**) so they line up.
6. If the wheels will go parallel but not coplanar, shim the required wheel out as necessary, using thin $\frac{3}{4}$ " washers on the shaft behind the wheel.
7. **Figure 65** shows the positions of the wheels when coplanar. When your wheels are coplanar, readjust the guide blocks and rear support bearings, and replace the wheel covers.

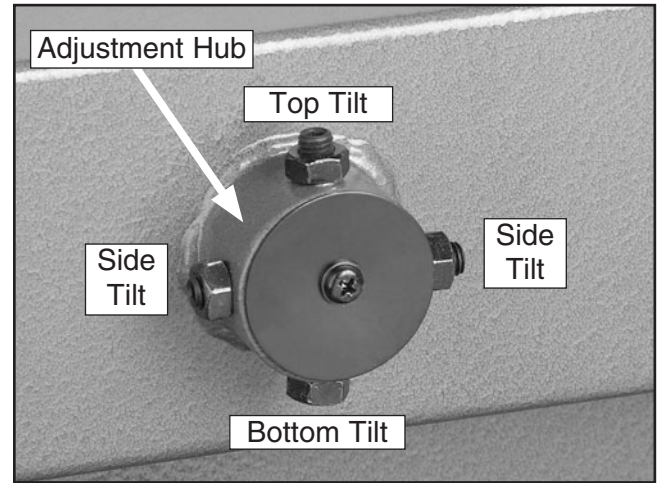

Figure 64. Lower wheel adjustment control.

Note: *The blade may track slightly off-center when the wheels are coplanar. This is natural because the blade will be balanced on the crown of the tire, rather than just in the center of the tire. This will be more noticeable with larger blades.*

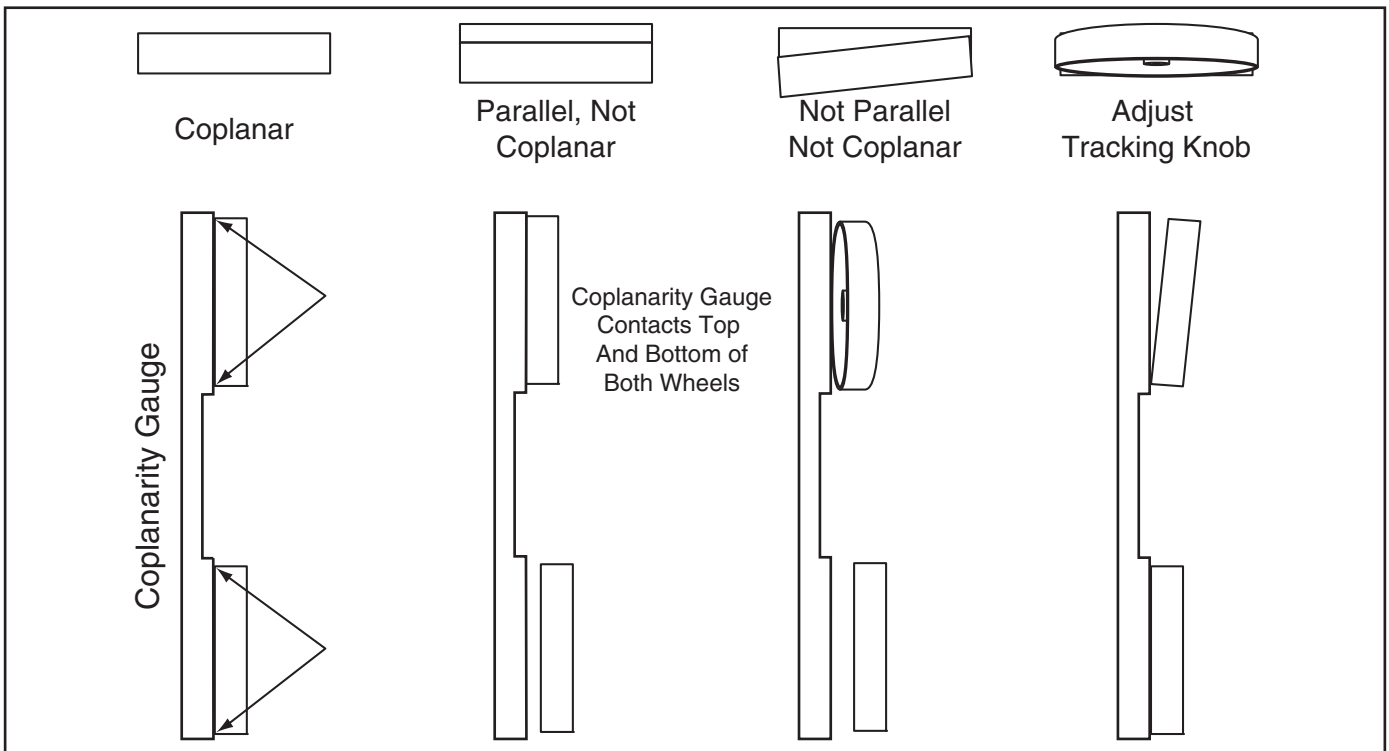

Figure 65. Coplanarity diagram.



WARRANTY AND RETURNS

Grizzly Industrial, Inc. warrants every product it sells for a period of **1 year** to the original purchaser from the date of purchase. This warranty does not apply to defects due directly or indirectly to misuse, abuse, negligence, accidents, repairs or alterations or lack of maintenance. This is Grizzly's sole written warranty and any and all warranties that may be implied by law, including any merchantability or fitness, for any particular purpose, are hereby limited to the duration of this written warranty. We do not warrant or represent that the merchandise complies with the provisions of any law or acts unless the manufacturer so warrants. In no event shall Grizzly's liability under this warranty exceed the purchase price paid for the product and any legal actions brought against Grizzly shall be tried in the State of Washington, County of Whatcom.

We shall in no event be liable for death, injuries to persons or property or for incidental, contingent, special, or consequential damages arising from the use of our products.

To take advantage of this warranty, contact us by mail or phone and give us all the details. We will then issue you a "Return Number," which must be clearly posted on the outside as well as the inside of the carton. We will not accept any item back without this number. Proof of purchase must accompany the merchandise.

The manufacturers reserve the right to change specifications at any time because they constantly strive to achieve better quality equipment. We make every effort to ensure that our products meet high quality and durability standards and we hope you never need to use this warranty.

Please feel free to write or call us if you have any questions about the machine or the manual.

Thank you again for your business and continued support. We hope to serve you again soon.





WARRANTY CARD

Name _____
 Street _____
 City _____ State _____ Zip _____
 Phone # _____ Email _____ Invoice # _____
 Model # _____ Order # _____ Serial # _____

The following information is given on a voluntary basis. It will be used for marketing purposes to help us develop better products and services. **Of course, all information is strictly confidential.**

1. How did you learn about us?

Advertisement Friend Catalog
 Card Deck Website Other:

2. Which of the following magazines do you subscribe to?

<input type="checkbox"/> Cabinet Maker	<input type="checkbox"/> Popular Mechanics	<input type="checkbox"/> Today's Homeowner
<input type="checkbox"/> Family Handyman	<input type="checkbox"/> Popular Science	<input type="checkbox"/> Wood
<input type="checkbox"/> Hand Loader	<input type="checkbox"/> Popular Woodworking	<input type="checkbox"/> Wooden Boat
<input type="checkbox"/> Handy	<input type="checkbox"/> Practical Homeowner	<input type="checkbox"/> Woodshop News
<input type="checkbox"/> Home Shop Machinist	<input type="checkbox"/> Precision Shooter	<input type="checkbox"/> Woodsmith
<input type="checkbox"/> Journal of Light Cont.	<input type="checkbox"/> Projects in Metal	<input type="checkbox"/> Woodwork
<input type="checkbox"/> Live Steam	<input type="checkbox"/> RC Modeler	<input type="checkbox"/> Woodworker West
<input type="checkbox"/> Model Airplane News	<input type="checkbox"/> Rifle	<input type="checkbox"/> Woodworker's Journal
<input type="checkbox"/> Modeltec	<input type="checkbox"/> Shop Notes	<input type="checkbox"/> Other:
<input type="checkbox"/> Old House Journal	<input type="checkbox"/> Shotgun News	

3. What is your annual household income?

\$20,000-\$29,000 \$30,000-\$39,000 \$40,000-\$49,000
 \$50,000-\$59,000 \$60,000-\$69,000 \$70,000+

4. What is your age group?

20-29 30-39 40-49
 50-59 60-69 70+

5. How long have you been a woodworker/metalworker?

0-2 Years 2-8 Years 8-20 Years 20+ Years

6. How many of your machines or tools are Grizzly?

0-2 3-5 6-9 10+

7. Do you think your machine represents a good value?

Yes No

8. Would you recommend Grizzly Industrial to a friend?

Yes No

9. Would you allow us to use your name as a reference for Grizzly customers in your area?

Note: We never use names more than 3 times. Yes No

10. Comments: _____

CUT ALONG DOTTED LINE

FOLD ALONG DOTTED LINE



Place
Stamp
Here



GRIZZLY INDUSTRIAL, INC.
P.O. BOX 2069
BELLINGHAM, WA 98227-2069



FOLD ALONG DOTTED LINE

Send a Grizzly Catalog to a friend:

Name _____
Street _____
City _____ State _____ Zip _____

TAPE ALONG EDGES--PLEASE DO NOT STAPLE

grizzly.com[®]

TOOL WEBSITE

Buy Direct and Save with Grizzly[®] – Trusted, Proven and a Great Value!
~Since 1983~

*Visit Our Website Today For
Current Specials!*

**ORDER
24 HOURS A DAY!
1-800-523-4777**



Free Manuals Download Website

<http://myh66.com>

<http://usermanuals.us>

<http://www.somanuals.com>

<http://www.4manuals.cc>

<http://www.manual-lib.com>

<http://www.404manual.com>

<http://www.luxmanual.com>

<http://aubethermostatmanual.com>

Golf course search by state

<http://golfingnear.com>

Email search by domain

<http://emailbydomain.com>

Auto manuals search

<http://auto.somanuals.com>

TV manuals search

<http://tv.somanuals.com>