

Grizzly **Industrial, Inc.**®

MODEL G0775 **20" HEAVY-DUTY** **DISC SANDER** **OWNER'S MANUAL** *(For models manufactured since 11/14)*



COPYRIGHT © JANUARY, 2015 BY GRIZZLY INDUSTRIAL, INC.,
**WARNING: NO PORTION OF THIS MANUAL MAY BE REPRODUCED IN ANY SHAPE
OR FORM WITHOUT THE WRITTEN APPROVAL OF GRIZZLY INDUSTRIAL, INC.**
#BLMN17030 PRINTED IN TAIWAN

V1.01.15



WARNING!

This manual provides critical safety instructions on the proper setup, operation, maintenance, and service of this machine/tool. Save this document, refer to it often, and use it to instruct other operators.

Failure to read, understand and follow the instructions in this manual may result in fire or serious personal injury—including amputation, electrocution, or death.

The owner of this machine/tool is solely responsible for its safe use. This responsibility includes but is not limited to proper installation in a safe environment, personnel training and usage authorization, proper inspection and maintenance, manual availability and comprehension, application of safety devices, cutting/sanding/grinding tool integrity, and the usage of personal protective equipment.

The manufacturer will not be held liable for injury or property damage from negligence, improper training, machine modifications or misuse.



WARNING!

Some dust created by power sanding, sawing, grinding, drilling, and other construction activities contains chemicals known to the State of California to cause cancer, birth defects or other reproductive harm. Some examples of these chemicals are:

- **Lead from lead-based paints.**
- **Crystalline silica from bricks, cement and other masonry products.**
- **Arsenic and chromium from chemically-treated lumber.**

Your risk from these exposures varies, depending on how often you do this type of work. To reduce your exposure to these chemicals: Work in a well ventilated area, and work with approved safety equipment, such as those dust masks that are specially designed to filter out microscopic particles.

Table of Contents

INTRODUCTION.....	2	SECTION 6: MAINTENANCE.....	23
Machine Description	2	Schedule	23
Contact Info.....	2	Cleaning & Protecting	23
Manual Accuracy	2	SECTION 7: SERVICE	24
Identification.....	3	Troubleshooting	24
Machine Data Sheet	4	Table Gap & Parallelism.....	26
SECTION 1: SAFETY	6	Calibrating Miter Gauge.....	26
Safety Instructions for Machinery	6	Table Tilt Calibration.....	27
Additional Safety for Disc Sanders	8	SECTION 8: WIRING.....	28
SECTION 2: POWER SUPPLY	9	Wiring Safety Instructions	28
SECTION 3: SETUP	11	Electrical Components.....	29
Unpacking	11	Wiring Diagram	30
Needed for Setup.....	11	SECTION 9: PARTS	31
Inventory	12	Main Breakdown	31
Cleanup.....	13	Labels and Cosmetics	33
Site Considerations.....	14	WARRANTY & RETURNS	37
Anchoring to Floor	15		
Assembly	15		
Dust Collection.....	16		
Test Run	16		
SECTION 4: OPERATIONS	17		
Operation Overview	17		
Attaching Sandpaper	18		
Disc Sanding.....	18		
SECTION 5: ACCESSORIES	20		

INTRODUCTION

Machine Description

The Model G0775 features a 2 HP, 220V, 1720 RPM motor equipped with a built-in motor brake for quickly stopping the 20" diameter sanding disc, and a pedestal-mounted magnetic switch. It includes a miter gauge and a large, tilting, cast iron sanding table with X and Y miter slots, which make it possible to sand many types of materials at virtually any angle—including compound angles—with precision and control. The steel powder-coated base has a 4" OD dust port and a large cabinet for storing extra sanding discs.

Contact Info

We stand behind our machines. If you have any questions or need help, use the information below to contact us. Before contacting, please get the serial number and manufacture date of your machine. This will help us help you faster.

Grizzly Technical Support
1203 Lycoming Mall Circle
Muncy, PA 17756
Phone: (570) 546-9663
Email: techsupport@grizzly.com

We want your feedback on this manual. What did you like about it? Where could it be improved? Please take a few minutes to give us feedback.

Grizzly Documentation Manager
P.O. Box 2069
Bellingham, WA 98227-2069
Email: manuals@grizzly.com

Manual Accuracy

We are proud to provide a high-quality owner's manual with your new machine!

We made every effort to be exact with the instructions, specifications, drawings, and photographs contained inside. Sometimes we make mistakes, but our policy of continuous improvement also means that **sometimes the machine you receive will be slightly different than what is shown in the manual.**

If you find this to be the case, and the difference between the manual and machine leaves you confused about a procedure, check our website for an updated version. We post current manuals and manual updates for free on our website at www.grizzly.com.

Alternatively, you can call our Technical Support for help. Before calling, please write down the **Manufacture Date** and **Serial Number** stamped into the machine ID label (see below). This information helps us determine if updated documentation is available for your machine.

		MODEL GXXXX MACHINE NAME	
SPECIFICATIONS		▲ WARNING!	
Motor:		To reduce risk of serious injury when using this machine:	
Specification:		1. Read manual before operation.	
Specification:		2. Wear safety glasses and respirator.	
Specification:		3. Make sure the motor has stopped and disconnect power before adjustments, maintenance, or service.	
Specification:		4. DO NOT expose to rain or dampness.	
Weight:		5. DO NOT modify this machine in any way.	
		6. DO NOT modify this machine in any way.	
		7.	
		8.	
		9.	
		10. Maintain machine carefully to prevent accidents.	

Manufactured for Grizzly in Taiwan

Manufacture Date []

Serial Number []



Identification

Become familiar with the names and locations of the controls and features shown below to better understand the instructions in this manual.

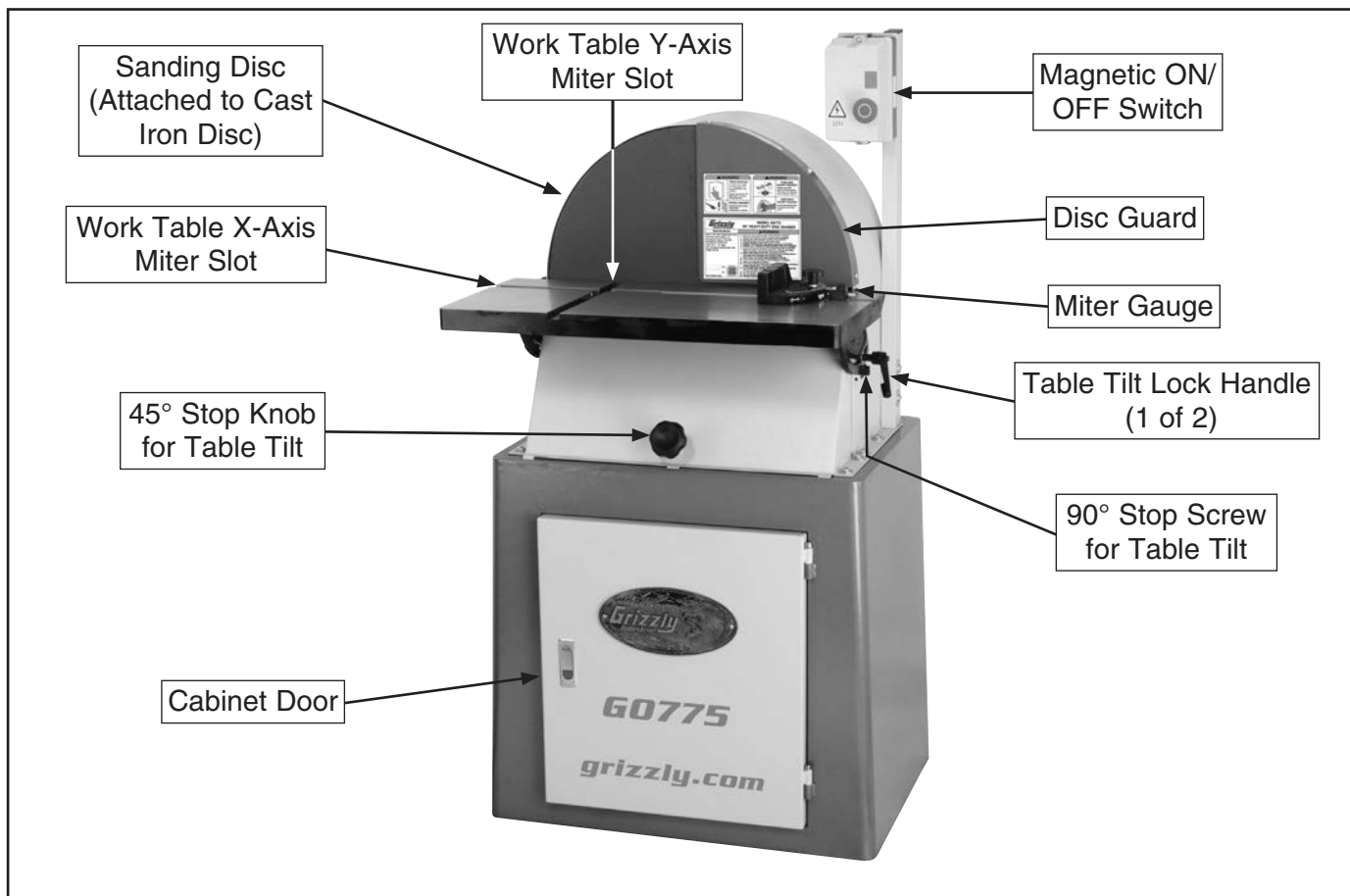

Figure 1. Model G0775 identification.





MACHINE DATA SHEET

Customer Service #: (570) 546-9663 · To Order Call: (800) 523-4777 · Fax #: (800) 438-5901

MODEL G0775 20" HEAVY-DUTY DISC SANDER

Product Dimensions:

Weight..... 392 lbs.
 Width (side-to-side) x Depth (front-to-back) x Height..... 25 x 28-1/2 x 51-1/4 in.
 Footprint (Length x Width)..... 26-1/2 x 19 in.

Shipping Dimensions:

Type..... Cardboard Box with Wood Base
 Content..... Machine
 Weight..... 434 lbs.
 Length x Width x Height..... 29 x 28 x 56 in.
 Must Ship Upright..... Yes

Electrical:

Power Requirement..... 220V, Single-Phase, 60 Hz
 Full-Load Current Rating..... 9.5A
 Minimum Circuit Size..... 15A
 Connection Type..... Cord & Plug
 Power Cord Included..... Yes
 Power Cord Length..... 6 ft.
 Power Cord Gauge..... 14 AWG
 Plug Included..... Yes
 Included Plug Type..... NEMA 6-15
 Switch Type..... Magnetic Switch

Motors:

Main

Type..... TEFC Capacitor-Start w/Brake
 Horsepower..... 2 HP
 Phase..... Single-Phase
 Amps..... 9.5A
 Speed..... 1720 RPM
 Power Transfer Direct Drive
 Bearings..... Sealed & Permanently Lubricated

Main Specifications:

Disc Sander Info

Disc Diameter..... 20 in.
 Disc Speed..... 1720 RPM
 Disc Sandpaper Backing Type..... PSA
 Table Length..... 25-1/16 in.
 Table Width..... 12 in.
 Table Thickness..... 1-3/8 in.
 Table Tilt..... Right 45 deg.
 Table-to-Floor Height..... 36 in.



Construction Materials

Base.....	Steel
Stand.....	Steel
Table.....	Cast Iron
Frame.....	Steel
Disc.....	Cast Iron
Miter Gauge.....	Aluminum
Paint Type/Finish.....	Powder-Coated

Other Related Info

Miter Gauge Slot Width.....	3/4 in.
Miter Gauge Slot Height.....	5/16 in.
Number of Dust Ports.....	1
Dust Port Size.....	4 in.
Compatible Mobile Base.....	D2057A

Other Specifications:

Country of Origin	Taiwan
Warranty	1 Year
Approximate Assembly & Setup Time	15 Minutes
Serial Number Location	ID Label
Sound Rating	75 dB
ISO 9001 Factory	Yes
CSA, ETL, or UL Certified/Listed	No

Features:

- Pedestal-mounted magnetic switch for convenience
- Accepts 20" PSA discs
- Large storage cabinet
- Cast iron table with X and Y miter slots
- Miter gauge
- Built-in motor brake for quick stops
- 4" dust port
- 45 degree table tilt



SECTION 1: SAFETY

For Your Own Safety, Read Instruction Manual Before Operating This Machine

The purpose of safety symbols is to attract your attention to possible hazardous conditions. This manual uses a series of symbols and signal words intended to convey the level of importance of the safety messages. The progression of symbols is described below. Remember that safety messages by themselves do not eliminate danger and are not a substitute for proper accident prevention measures. Always use common sense and good judgment.

 **DANGER** Indicates an imminently hazardous situation which, if not avoided, **WILL** result in death or serious injury.

 **WARNING** Indicates a potentially hazardous situation which, if not avoided, **COULD** result in death or serious injury.

 **CAUTION** Indicates a potentially hazardous situation which, if not avoided, **MAY** result in minor or moderate injury. It may also be used to alert against unsafe practices.

NOTICE This symbol is used to alert the user to useful information about proper operation of the machine.

Safety Instructions for Machinery

WARNING

OWNER'S MANUAL. Read and understand this owner's manual **BEFORE** using machine.

TRAINED OPERATORS ONLY. Untrained operators have a higher risk of being hurt or killed. Only allow trained/supervised people to use this machine. When machine is not being used, disconnect power, remove switch keys, or lock-out machine to prevent unauthorized use—especially around children. Make workshop kid proof!

DANGEROUS ENVIRONMENTS. Do not use machinery in areas that are wet, cluttered, or have poor lighting. Operating machinery in these areas greatly increases the risk of accidents and injury.

MENTAL ALERTNESS REQUIRED. Full mental alertness is required for safe operation of machinery. Never operate under the influence of drugs or alcohol, when tired, or when distracted.

ELECTRICAL EQUIPMENT INJURY RISKS. You can be shocked, burned, or killed by touching live electrical components or improperly grounded machinery. To reduce this risk, only allow qualified service personnel to do electrical installation or repair work, and always disconnect power before accessing or exposing electrical equipment.

DISCONNECT POWER FIRST. Always disconnect machine from power supply **BEFORE** making adjustments, changing tooling, or servicing machine. This prevents an injury risk from unintended startup or contact with live electrical components.

EYE PROTECTION. Always wear ANSI-approved safety glasses or a face shield when operating or observing machinery to reduce the risk of eye injury or blindness from flying particles. Everyday eyeglasses are **NOT** approved safety glasses.



WARNING

WEARING PROPER APPAREL. Do not wear clothing, apparel or jewelry that can become entangled in moving parts. Always tie back or cover long hair. Wear non-slip footwear to avoid accidental slips, which could cause loss of workpiece control.

HAZARDOUS DUST. Dust created while using machinery may cause cancer, birth defects, or long-term respiratory damage. Be aware of dust hazards associated with each workpiece material, and always wear a NIOSH-approved respirator to reduce your risk.

HEARING PROTECTION. Always wear hearing protection when operating or observing loud machinery. Extended exposure to this noise without hearing protection can cause permanent hearing loss.

REMOVE ADJUSTING TOOLS. Tools left on machinery can become dangerous projectiles upon startup. Never leave chuck keys, wrenches, or any other tools on machine. Always verify removal before starting!

USE CORRECT TOOL FOR THE JOB. Only use this tool for its intended purpose—do not force it or an attachment to do a job for which it was not designed. Never make unapproved modifications—modifying tool or using it differently than intended may result in malfunction or mechanical failure that can lead to personal injury or death!

AWKWARD POSITIONS. Keep proper footing and balance at all times when operating machine. Do not overreach! Avoid awkward hand positions that make workpiece control difficult or increase the risk of accidental injury.

CHILDREN & BYSTANDERS. Keep children and bystanders at a safe distance from the work area. Stop using machine if they become a distraction.

GUARDS & COVERS. Guards and covers reduce accidental contact with moving parts or flying debris. Make sure they are properly installed, undamaged, and working correctly.

FORCING MACHINERY. Do not force machine. It will do the job safer and better at the rate for which it was designed.

NEVER STAND ON MACHINE. Serious injury may occur if machine is tipped or if the cutting tool is unintentionally contacted.

STABLE MACHINE. Unexpected movement during operation greatly increases risk of injury or loss of control. Before starting, verify machine is stable and mobile base (if used) is locked.

USE RECOMMENDED ACCESSORIES. Consult this owner's manual or the manufacturer for recommended accessories. Using improper accessories will increase the risk of serious injury.

UNATTENDED OPERATION. To reduce the risk of accidental injury, turn machine **OFF** and ensure all moving parts completely stop before walking away. Never leave machine running while unattended.

MAINTAIN WITH CARE. Follow all maintenance instructions and lubrication schedules to keep machine in good working condition. A machine that is improperly maintained could malfunction, leading to serious personal injury or death.

CHECK DAMAGED PARTS. Regularly inspect machine for any condition that may affect safe operation. Immediately repair or replace damaged or mis-adjusted parts before operating machine.

MAINTAIN POWER CORDS. When disconnecting cord-connected machines from power, grab and pull the plug—NOT the cord. Pulling the cord may damage the wires inside. Do not handle cord/plug with wet hands. Avoid cord damage by keeping it away from heated surfaces, high traffic areas, harsh chemicals, and wet/damp locations.

EXPERIENCING DIFFICULTIES. If at any time you experience difficulties performing the intended operation, stop using the machine! Contact our Technical Support at (570) 546-9663.



Additional Safety for Disc Sanders

WARNING

Serious injury or death can occur from fingers or hands contacting sandpaper, or from fingers, clothes, or hair getting entangled in sanding disc. Workpieces thrown by sander can strike nearby operators with great force. Long-term respiratory damage can occur from using sander without a respirator and adequate dust collection system. To minimize risk of getting hurt or killed, anyone operating machine MUST completely heed hazards and warnings below.

DISC DIRECTION. Only sand on downward-moving left side of sanding disc. Sanding on upward-moving right side of sanding disc forces operator to rely only on hands (rather than table) for support, which increases risk of workpiece “kick-out” and impact/abrasion injuries.

HAND PLACEMENT. Rotating sandpaper can remove a large amount of flesh in a few seconds. Always keep hands away from sandpaper during operation. Never touch moving sandpaper on purpose. Use a brush to clean table of sawdust and chips.

FEEDING WORKPIECE. Forcefully jamming workpiece into sanding surface could cause workpiece to be aggressively grabbed and pull your hands into sanding surface. Firmly grasp workpiece in both hands and ease it into sandpaper using light pressure.

MINIMUM STOCK DIMENSION. Small workpieces can be aggressively pulled from your hands. Always use a jig or other holding device when sanding small workpieces, and keep hands and fingers at least 2” away from sanding surface.

AVOIDING ENTANGLEMENT. Becoming entangled in moving parts of this machine can cause pinching and crushing injuries. To avoid these hazards, DO NOT wear loose clothing, gloves, or jewelry, and tie back long hair. Keep all guards in place and secure.

IN-RUNNING NIP POINTS. The gap between moving sandpaper and fixed table/support creates a pinch point for fingers or workpieces; the larger this gap is, the greater risk of fingers or workpieces getting caught in it. Minimize this risk by adjusting table no more than $\frac{1}{16}$ ” away from sandpaper.

WORKPIECE SUPPORT. Workpiece kickback can occur with violent force if workpiece is not properly supported during operation. Always sand with workpiece firmly against table or another support device.

WORKPIECE INSPECTION. Nails, staples, knots, or other imperfections in workpiece can be dislodged and thrown from sander at high rate of speed into operator or bystanders, or cause damage to sandpaper or sander. Never try to sand stock that has embedded foreign objects or questionable imperfections.

SANDPAPER CONDITION. Worn or damaged sandpaper not only produces poor sanding results, but could fly apart, aggressively grab workpiece, and throw debris at the operator. Always inspect sandpaper before operation and replace if worn or damaged.

WORKPIECE INTEGRITY. Only sand solid workpieces that can withstand power sanding forces. Make sure shape of workpiece is properly supported on table; avoid sanding workpieces without flat bottom surfaces unless some type of jig is used to maintain support and control when sanding force is applied.

SANDING DUST. Sanding creates large amounts of dust and flying chips that can lead to eye injury or respiratory illness. Reduce risk of these hazards by wearing approved eye and respiratory protection when using sander.

DUST COLLECTION. Never operate without adequate dust collection system in place and running. Proper dust collection reduces dust in work area, which decreases risk of long-term respiratory damage, but it is not a substitute for using a respirator.



SECTION 2: POWER SUPPLY

Availability

Before installing the machine, consider the availability and proximity of the required power supply circuit. If an existing circuit does not meet the requirements for this machine, a new circuit must be installed. To minimize the risk of electrocution, fire, or equipment damage, installation work and electrical wiring must be done by an electrician or qualified service personnel in accordance with all applicable codes and standards.

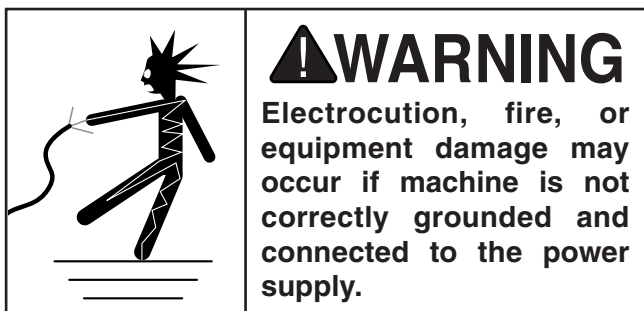

Full-Load Current Rating

The full-load current rating is the amperage a machine draws at 100% of the rated output power. On machines with multiple motors, this is the amperage drawn by the largest motor or sum of all motors and electrical devices that might operate at one time during normal operations.

Full-Load Current Rating at 220V 9.5 Amps

The full-load current is not the maximum amount of amps that the machine will draw. If the machine is overloaded, it will draw additional amps beyond the full-load rating.

If the machine is overloaded for a sufficient length of time, damage, overheating, or fire may result—especially if connected to an undersized circuit. To reduce the risk of these hazards, avoid overloading the machine during operation and make sure it is connected to a power supply circuit that meets the specified circuit requirements.

Circuit Information

A power supply circuit includes all electrical equipment between the breaker box or fuse panel in the building and the machine. The power supply circuit used for this machine must be sized to safely handle the full-load current drawn from the machine for an extended period of time. (If this machine is connected to a circuit protected by fuses, use a time delay fuse marked D.)

! CAUTION

For your own safety and protection of property, consult an electrician if you are unsure about wiring practices or electrical codes in your area.

Note: *Circuit requirements in this manual apply to a dedicated circuit—where only one machine will be running on the circuit at a time. If machine will be connected to a shared circuit where multiple machines may be running at the same time, consult an electrician or qualified service personnel to ensure circuit is properly sized for safe operation.*

Circuit Requirements

This machine is prewired to operate on a power supply circuit that has a verified ground and meets the following requirements:

Nominal Voltage 208V, 220V, 230V, 240V
Cycle 60 Hz
Phase Single-Phase
Power Supply Circuit 15 Amps
Plug/Receptacle NEMA 6-15



Grounding Requirements

This machine **MUST** be grounded. In the event of certain malfunctions or breakdowns, grounding reduces the risk of electric shock by providing a path of least resistance for electric current.

This machine is equipped with a power cord that has an equipment-grounding wire and a grounding plug. Only insert plug into a matching receptacle (outlet) that is properly installed and grounded in accordance with all local codes and ordinances. **DO NOT** modify the provided plug!

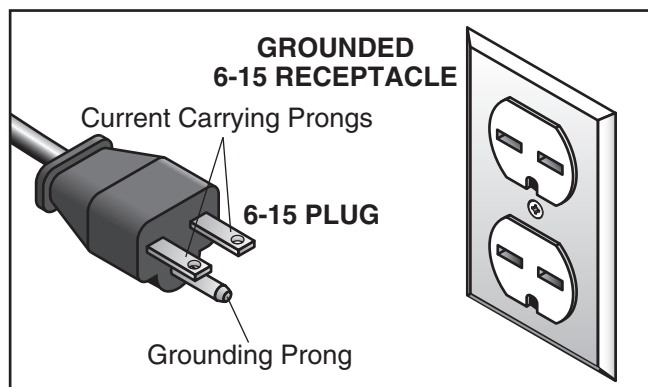
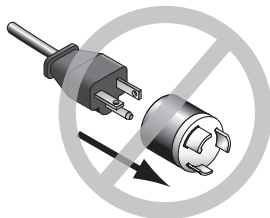

Figure 2. Typical 6-15 plug and receptacle.

CAUTION



No adapter should be used with the plug. If plug does not fit the available receptacle, or if machine must be reconnected for use on a different type of circuit, the reconnection must be performed by an electrician or qualified service personnel, and it must comply with all local codes and ordinances.

WARNING

Serious injury could occur if you connect the machine to power before completing the setup process. DO NOT connect to power until instructed later in this manual.

Improper connection of the equipment-grounding wire can result in a risk of electric shock. The wire with green insulation (with or without yellow stripes) is the equipment-grounding wire. If repair or replacement of the power cord or plug is necessary, do not connect the equipment-grounding wire to a live (current carrying) terminal.

Check with a qualified electrician or service personnel if you do not understand these grounding requirements, or if you are in doubt about whether the tool is properly grounded. If you ever notice that a cord or plug is damaged or worn, disconnect it from power, and immediately replace it with a new one.

Extension Cords

We do not recommend using an extension cord with this machine. If you must use an extension cord, only use it if absolutely necessary and only on a temporary basis.

Extension cords cause voltage drop, which can damage electrical components and shorten motor life. Voltage drop increases as the extension cord size gets longer and the gauge size gets smaller (higher gauge numbers indicate smaller sizes).

Any extension cord used with this machine must be in good condition and contain a ground wire and matching plug/receptacle. Additionally, it must meet the following size requirements:

**Minimum Gauge Size 14 AWG
Maximum Length (Shorter is Better).....50 ft.**



SECTION 3: SETUP

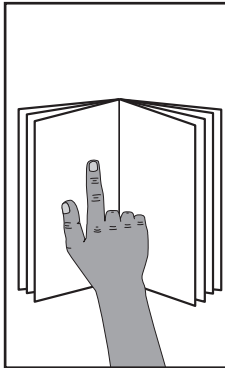

!WARNING

This machine presents serious injury hazards to untrained users. Read through this entire manual to become familiar with the controls and operations before starting the machine!

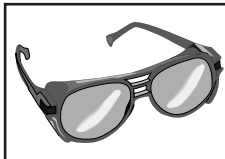

!WARNING

Wear safety glasses during the entire setup process!

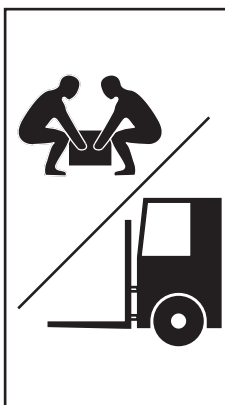

!WARNING

HEAVY LIFT!

Straining or crushing injury may occur from improperly lifting machine or some of its parts. To reduce this risk, get help from other people and use a forklift (or other lifting equipment) rated for weight of this machine.

Unpacking

Your machine was carefully packaged for safe transportation. Remove the packaging materials from around your machine and inspect it. If you discover any damage, *please call us immediately at (570) 546-9663 for advice.*

Save the containers and all packing materials for possible inspection by the carrier or its agent. *Otherwise, filing a freight claim can be difficult.*

When you are completely satisfied with the condition of your shipment, inventory the contents.

Needed for Setup

The following are needed to complete the setup process:

Description

- Safety Glasses
- Cleaner/Degreaser
- Disposable Shop Rags
- Forklift
- Dust Collection System
- Dust Hose 4"
- Hose Clamps 4"



!WARNING

SUFFOCATION HAZARD!

Keep children and pets away from plastic bags or packing materials shipped with this machine. Discard immediately.



Inventory

The following is a list of items shipped with your machine. Before beginning setup, lay these items out and inventory them.

If any non-proprietary parts are missing (e.g. a nut or a washer), we will gladly replace them; or for the sake of expediency, replacements can be obtained at your local hardware store.

NOTICE

If you cannot find an item on this list, carefully check around/inside the machine and packaging materials. Often, these items get lost in packaging materials while unpacking or they are pre-installed at the factory.

Main Components (Figure 3)	Qty
A. Sander Assembly	1
B. Magnetic Switch Pedestal	1
C. Miter Gauge.....	1
D. Open-End Wrench 10x13mm (Not Shown)	1
E. Radius Sanding Attachment (Not Shown)..	1
F. Hex Wrenches 2.5, 5mm (Not Shown)..	1 Ea

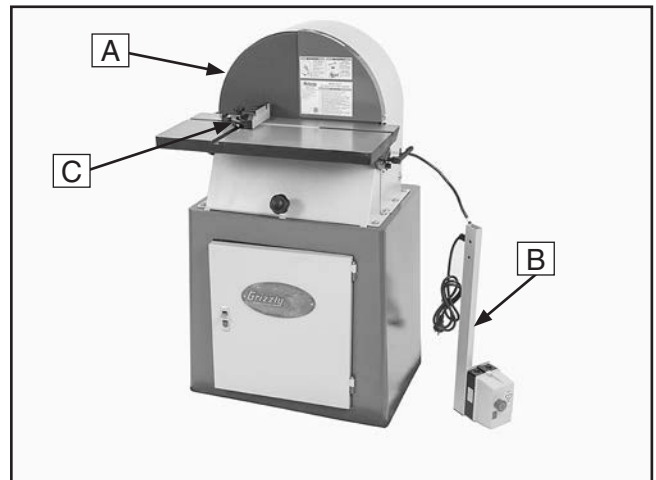

Figure 3. Model G0775 inventory.



Cleanup

The unpainted surfaces of your machine are coated with a heavy-duty rust preventative that prevents corrosion during shipment and storage. This rust preventative works extremely well, but it will take a little time to clean.

Be patient and do a thorough job cleaning your machine. The time you spend doing this now will give you a better appreciation for the proper care of your machine's unpainted surfaces.

There are many ways to remove this rust preventative, but the following steps work well in a wide variety of situations. Always follow the manufacturer's instructions with any cleaning product you use and make sure you work in a well-ventilated area to minimize exposure to toxic fumes.

Before cleaning, gather the following:

- Disposable rags
- Cleaner/degreaser (WD-40 works well)
- Safety glasses & disposable gloves
- Plastic paint scraper (optional)

Basic steps for removing rust preventative:

1. Put on safety glasses.
2. Coat the rust preventative with a liberal amount of cleaner/degreaser, then let it soak for 5–10 minutes.
3. Wipe off the surfaces. If your cleaner/degreaser is effective, the rust preventative will wipe off easily. If you have a plastic paint scraper, scrape off as much as you can first, then wipe off the rest with the rag.
4. Repeat **Steps 2–3** as necessary until clean, then coat all unpainted surfaces with a quality metal protectant to prevent rust.

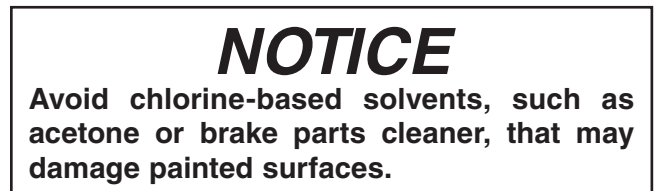
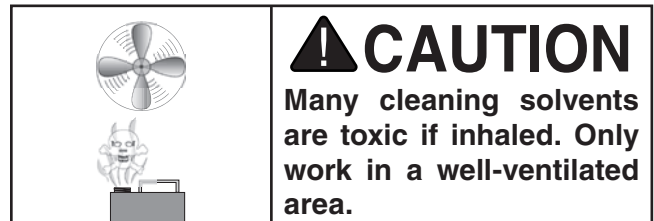
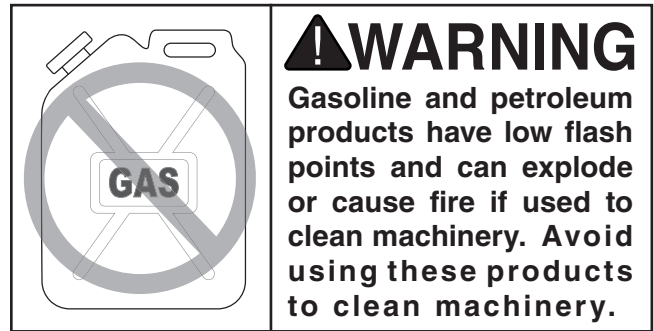

T23692—Orange Power Degreaser

A great product for removing the waxy shipping grease from your machine during clean up.



Figure 4. T23692 Orange Power Degreaser.



Site Considerations

Weight Load

Refer to the **Machine Data Sheet** for the weight of your machine. Make sure that the surface upon which the machine is placed will bear the weight of the machine, additional equipment that may be installed on the machine, and the heaviest workpiece that will be used. Additionally, consider the weight of the operator and any dynamic loading that may occur when operating the machine.

Space Allocation

Consider the largest size of workpiece that will be processed through this machine and provide enough space around the machine for adequate operator material handling or the installation of auxiliary equipment. With permanent installations, leave enough space around the machine to open or remove doors/covers as required by the maintenance and service described in this manual. **See below for required space allocation.**

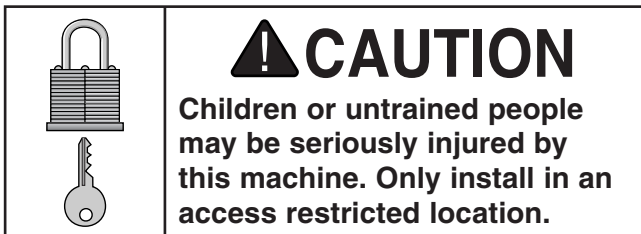

Physical Environment

The physical environment where the machine is operated is important for safe operation and longevity of machine components. For best results, operate this machine in a dry environment that is free from excessive moisture, hazardous chemicals, airborne abrasives, or extreme conditions. Extreme conditions for this type of machinery are generally those where the ambient temperature range exceeds 41°–104°F; the relative humidity range exceeds 20%–95% (non-condensing); or the environment is subject to vibration, shocks, or bumps.

Electrical Installation

Place this machine near an existing power source. Make sure all power cords are protected from traffic, material handling, moisture, chemicals, or other hazards. Make sure to leave enough space around machine to disconnect power supply or apply a lockout/tagout device, if required.

Lighting

Lighting around the machine must be adequate enough that operations can be performed safely. Shadows, glare, or strobe effects that may distract or impede the operator must be eliminated.

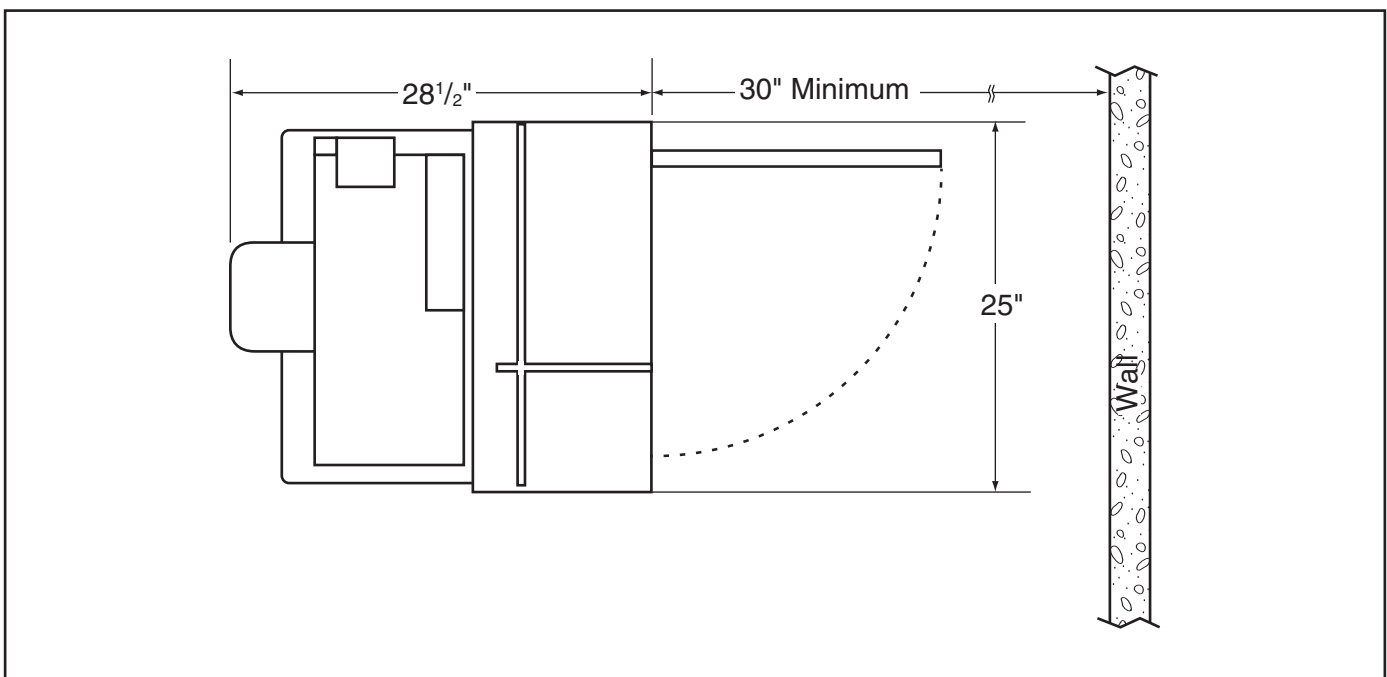

Figure 5. Minimum working clearances.



Anchoring to Floor

Number of Mounting Holes 4
Diameter of Mounting Hardware..... 5/16"

Anchoring machinery to the floor prevents tipping or shifting and reduces vibration that may occur during operation, resulting in a machine that runs slightly quieter and feels more solid.

If the machine will be installed in a commercial or workplace setting, or if it is permanently connected (hardwired) to the power supply, local codes may require that it be anchored to the floor.

If not required by any local codes, fastening the machine to the floor is an optional step. If you choose not to do this with your machine, we recommend placing it on machine mounts, as these provide an easy method for leveling and they have vibration-absorbing pads.

Anchoring to Concrete Floors

Lag shield anchors with lag screws (see below) are a popular way to anchor machinery to a concrete floor, because the anchors sit flush with the floor surface, making it easy to unbolt and move the machine later, if needed. However, anytime local codes apply, you **MUST** follow the anchoring methodology specified by the code.

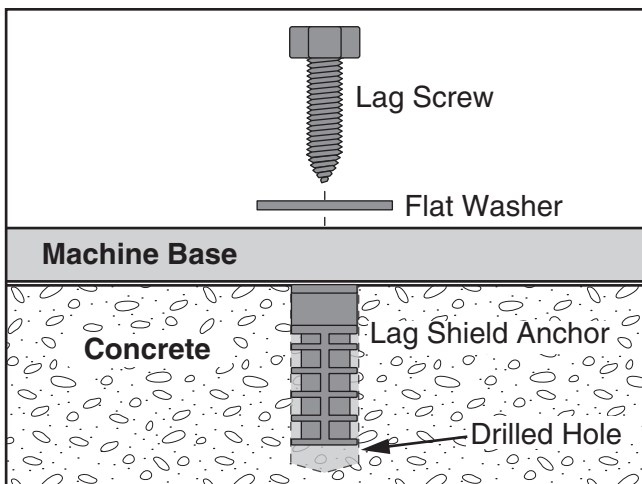

Figure 6. Popular method for anchoring machinery to a concrete floor.

Assembly

The magnetic switch pedestal must be mounted to the sander to operate the sander.

To mount pedestal:

1. Mount magnetic switch pedestal to sander with two included M8-1.25 x 45 button head cap screws and fender washers, as shown in **Figure 7**.

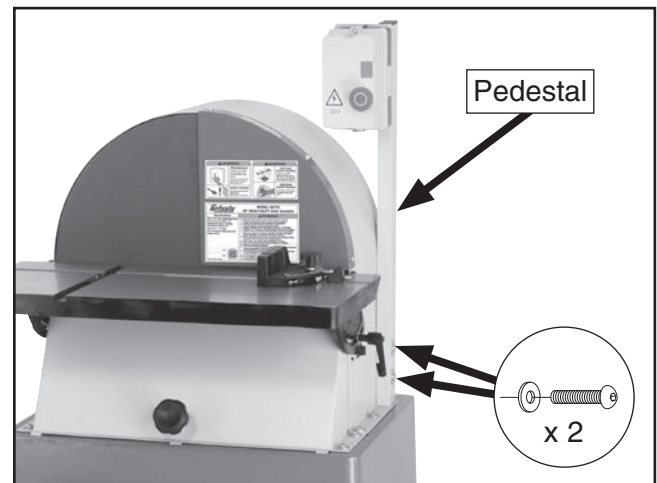

Figure 7. Magnetic switch pedestal mounted.



Dust Collection

⚠ CAUTION

This machine creates substantial amounts of dust during operation. Breathing airborne dust on a regular basis can result in permanent respiratory illness. Reduce your risk by wearing a respirator and capturing the dust with a dust collection system.

Recommended CFM at Dust Port: 400 CFM

Do not confuse this CFM recommendation with the rating of the dust collector. To determine the CFM at the dust port, you must consider these variables: (1) CFM rating of the dust collector, (2) hose type and length between the dust collector and the machine, (3) number of branches or wyes, and (4) amount of other open lines throughout the system. Explaining how to calculate these variables is beyond the scope of this manual. Consult an expert or purchase a good dust collection "how-to" book.

To connect a dust collection hose:

1. Fit 4" dust hose over dust port, as shown in **Figure 8**, and secure in place with hose clamp.



Figure 8. Dust hose attached to dust port.

2. Tug hose to make sure it does not come off.

Note: A tight fit is necessary for proper performance.

Test Run

Once assembly is complete, test run the machine to ensure it is properly connected to power and safety components are functioning properly.

If you find an unusual problem during the test run, immediately stop the machine, disconnect it from power, and fix the problem **BEFORE** operating the machine again. The **Troubleshooting** table in the **SERVICE** section of this manual can help.

⚠ WARNING

Serious injury or death can result from using this machine **BEFORE** understanding its controls and related safety information. **DO NOT** operate, or allow others to operate, machine until the information is understood.

⚠ WARNING

DO NOT start machine until all preceding setup instructions have been performed. Operating an improperly set up machine may result in malfunction or unexpected results that can lead to serious injury, death, or machine/property damage.

To test run machine:

1. Clear all setup tools away from machine.
2. Spin sanding disc by hand to make sure sandpaper does not touch table.
 - If sandpaper touches table, loosen hex bolts that secure table to support brackets, then follow **Steps 3–5** on **Page 26** to adjust table gap.
3. Connect machine to power supply.
4. Turn machine **ON**, verify motor operation, and then turn machine **OFF**.

The motor should run smoothly and without unusual problems or noises.



SECTION 4: OPERATIONS

Operation Overview

The purpose of this overview is to provide the novice machine operator with a basic understanding of how the machine is used during operation, so the machine controls/components discussed later in this manual are easier to understand.

Due to the generic nature of this overview, it is **not** intended to be an instructional guide. To learn more about specific operations, read this entire manual and seek additional training from experienced machine operators, and do additional research outside of this manual by reading "how-to" books, trade magazines, or websites.

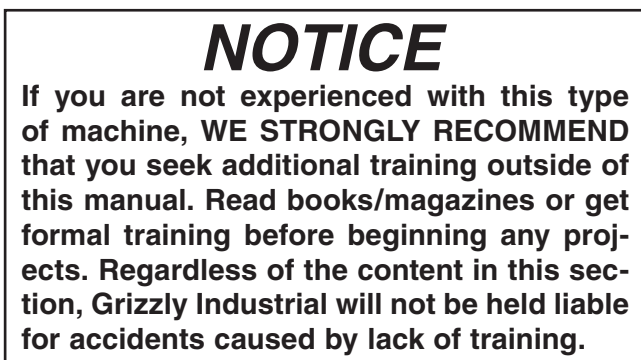
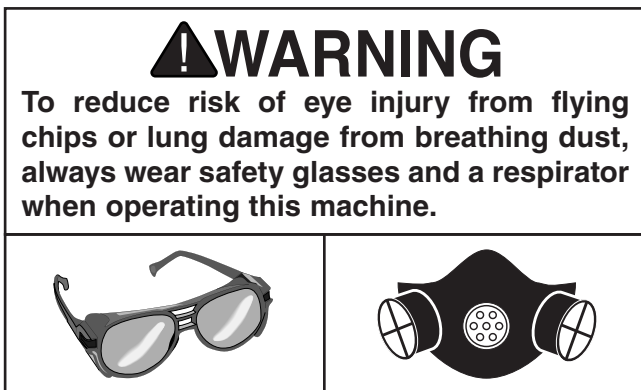

To complete a typical sanding operation, the operator does the following:

1. Examines workpiece to make sure it is suitable for sanding.
2. Adjusts table tilt if necessary and locks table in place.
3. If necessary, inserts miter gauge in either X-axis or Y-axis miter slots, adjusts miter gauge to required sanding angle, and locks it in place.
4. Puts on safety glasses and a respirator.
5. Starts machine and dust collector.
6. Holds workpiece firmly and flatly against both table and miter gauge (if used), pushes workpiece into or along down-spin side of sanding disc, and moves it to different locations to wear sandpaper evenly and prevent it from overheating.
7. Stops machine.



Attaching Sandpaper

The Model G0775 sander accepts 20" diameter PSA (pressure-sensitive adhesive) sanding discs. These are available in a variety of grits. The sandpaper can be replaced without removing the table.

To attach sandpaper:

1. DISCONNECT MACHINE FROM POWER!
2. Loosen six hex bolts that secure table to support brackets, and move table away from sanding disc.
3. Remove disc guard, peel off old sandpaper, clean disc surface with mineral spirits, and wipe it dry.
4. Peel back protective layer on **one-half** of sandpaper disc and fold it against remaining half.
5. Slip half with protective layer between disc and the table edge (see **Figure 9**).



Figure 9. Installing sandpaper.

6. Position exposed adhesive on upper half of disc that extends above table. Once it is positioned evenly across disc, press adhesive onto surface.
7. Rotate disc so lower half is above table. Peel off other half of protective paper, and press remaining sandpaper against disc so adhesion is complete.
8. Adjust table gap and parallelism (see **Page 26** for further details).
9. Tighten hex bolts and re-install disc guard.

Disc Sanding

The Model G0775 uses a dual-axis miter slot design for increased versatility of workpiece control.

⚠ CAUTION

Always keep disc guard in place and workpiece on side of wheel that is rotating downward. This will reduce likelihood of workpiece being ejected.

⚠ CAUTION

To reduce risk of your fingers getting trapped between work table and sanding disc, make sure the table is approximately $\frac{1}{16}$ " away from sanding disc.

To use sanding disc:

1. DISCONNECT MACHINE FROM POWER!
2. Set angle of table and miter gauge for your operation.
3. Make sure table is about $\frac{1}{16}$ " away from sanding disc. Refer to **Table Gap & Parallelism** on **Page 26** for further details.
4. Connect sander to power, turn it **ON**, and allow it to reach full speed.
5. With disc guard in place, position workpiece on work table against miter gauge.



6. With moderate pressure, push workpiece into down-spin side of rotating disc. See **Figures 10–13** below for examples of disc sanding.



Figure 10. Example of Y-axis sanding.



Figure 11. Example of X-axis sanding.



Figure 12. Example of angle sanding.



Figure 13. Example of sanding with table tilted.

Note: You can use the included radius sanding attachment to sand round workpieces. Insert the sanding attachment into the Y-axis. Mark the center of the workpiece with an awl or center punch. Place the center mark over the pivot point of the sanding attachment. Spin the workpiece clockwise against the down-spin side of the rotating disc.

Note: To perform sanding on compound-angle cuts, tilt the table and rotate the miter gauge to the appropriate angles.

Note: To prevent burning the workpiece and overloading the sanding disc, move the workpiece slowly back and forth from the left side of the sanding disc to the center and do not use excessive pressure.



SECTION 5: ACCESSORIES

! WARNING

Installing unapproved accessories may cause machine to malfunction, resulting in serious personal injury or machine damage. To reduce this risk, only install accessories recommended for this machine by Grizzly.

NOTICE

Refer to our website or latest catalog for additional recommended accessories.

20" PSA Sanding Discs

Model & Type	Grit
D1342 20" PSA.....	60
D1343 20" PSA.....	80
D1344 20" PSA.....	100
D1345 20" PSA.....	120
D1346 20" PSA.....	150
D1347 20" PSA.....	180
D1348 20" PSA.....	220



Figure 14. Sanding discs.

PRO-STICK® Abrasive Surface Cleaners

Extend the life of your sanding discs and sleeves! Choose the Pro-Stick® with a handle for greater control or without a handle for more usable area.

Size	Model
1½" X 1½" X 8½"	W1306
2" X 2" X 12"	W1307

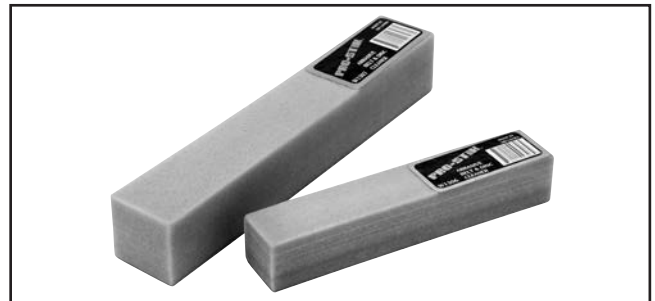

Figure 15. PRO-STICK® abrasive cleaners.

- D4206—Clear Flexible Hose 4" x 10'
- D4216—Black Flexible Hose 4" x 10'
- W1034—Heavy-Duty Clear Flex Hose 4" x 10'
- D2107—Hose Hanger 4¼"
- W1015—Y-Fitting 4" x 4" x 4"
- W1017—90° Elbow 4"
- W1019—Hose Coupler (Splice) 4"
- W1317—Wire Hose Clamp 4"
- W1007—Plastic Blast Gate 4"
- W1053—Anti-Static Grounding Kit

We've hand picked a selection of commonly used dust collection components for machines with 4" dust ports.



Figure 16. Dust collection accessories.

order online at www.grizzly.com or call 1-800-523-4777



T26779 3-in-1 Workpiece Support Stand

Rotating head features steel roller topped with 8 rolling balls. Adjusts in height from 27½" to 43". Unit folds for easy storage. Features heavy-duty steel frame, four outrigger legs for stability, adjustable foot for uneven floors, and 250 lb. capacity.



Figure 17. T26779 3-in-1 Roller Stand.

Basic Eye Protection

T20501—Face Shield Crown Protector 4"

T20502—Face Shield Crown Protector 7"

T20503—Face Shield Window

T20451—"Kirova" Clear Safety Glasses

T20452—"Kirova" Anti-Reflective S. Glasses

H7194—Bifocal Safety Glasses 1.5

H7195—Bifocal Safety Glasses 2.0

H7196—Bifocal Safety Glasses 2.5



Figure 18. Assortment of basic eye protection.

H2499—Small Half-Mask Respirator

H3631—Medium Half-Mask Respirator

H3632—Large Half-Mask Respirator

H3635—Cartridge Filter Pair P100

Wood dust has been linked to nasal cancer and severe respiratory illnesses. If you work around-dust everyday, a half-mask respirator can be a lifesaver. Also compatible with safety glasses!



Figure 19. Half-mask respirator with disposable cartridge filters.

Basic Hearing Protection

H4978—Deluxe Earmuffs - 27dB

H4979—Twin Cup Hearing Protector - 29dB

T20446—Ear Plugs 200 Pair - 31dB

A must have if you or employees operate for hours at a time.



Figure 20. Hearing protection assortment.

order online at www.grizzly.com or call 1-800-523-4777



D2057A—Heavy-Duty Shop Fox® Mobile Base
This patented base is the most stable on the market with outrigger type supports. Adjusts from 20" x 20½" to 29½" x 29½". 700 lb. capacity. Weighs 34 lbs.



Figure 21. D2057A Shop Fox Mobile Base.

G1163P—1HP Floor Model Dust Collector
G0710—1HP Wall-Mount Dust Collector
G3591—30 Micron Replacement Bag
H4340—3.0 Micron Upgrade Bag

Excellent point-of-use dust collectors that can be used next to the machine with only a small amount of ducting. Specifications: 450 CFM, 7.2" static pressure, 2 cubic foot bag, and 30 micron filter. Motor is 1HP, 120V/240V, 7A/3.5A.

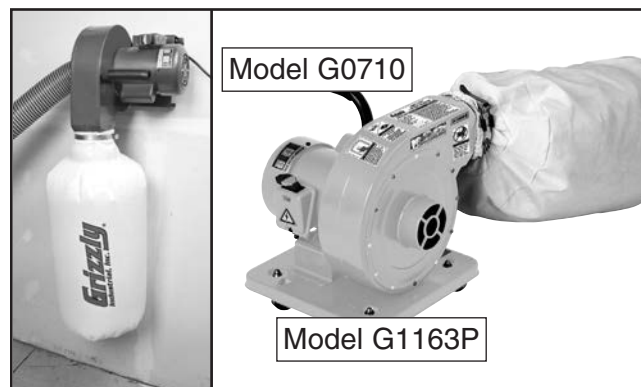
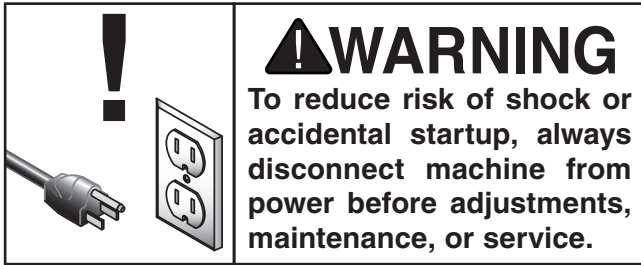

Figure 22. Point-of-use dust collectors.

order online at www.grizzly.com or call 1-800-523-4777



SECTION 6: MAINTENANCE



Schedule

For optimum performance from your machine, follow this maintenance schedule and refer to any specific instructions given in this section.

Daily Check

- Loose mounting bolts.
- Damaged or worn sandpaper.
- Worn or damaged wires.
- Any other unsafe condition.

Weekly/Monthly Check

- Vacuum dust off motor fan.

Cleaning & Protecting

Cleaning the Model G0775 is relatively easy. Vacuum excess wood chips and sawdust, and wipe off the remaining dust with a dry cloth. If any resin has built up, use a resin dissolving cleaner to remove it.

Protect the unpainted cast iron table by wiping it clean after every use—this ensures moisture from wood dust does not remain on bare metal surfaces. Keep the table rust-free with regular applications of products like G96® Gun Treatment, SLIPIT®, or Boeshield® T-9.

G5562—SLIPIT® 1 Qt. Gel

G5563—SLIPIT® 12 Oz. Spray

G2871—Boeshield® T-9 12 Oz. Spray

G2870—Boeshield® T-9 4 Oz. Spray

H3788—G96® Gun Treatment 12 Oz. Spray

H3789—G96® Gun Treatment 4.5 Oz. Spray



Figure 23. Recommended products for protecting unpainted cast iron/steel part on machinery.



SECTION 7: SERVICE

Review the troubleshooting and procedures in this section if a problem develops with your machine. If you need replacement parts or additional help with a procedure, call our Technical Support at (570) 546-9663.

Note: Please gather the serial number and manufacture date of your machine before calling.

Troubleshooting

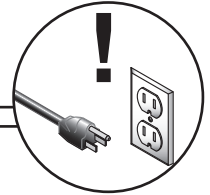

Motor & Electrical

Symptom	Possible Cause	Possible Solution
Machine does not start or a circuit breaker trips.	<ol style="list-style-type: none"> 1. Incorrect power supply voltage or circuit size. 2. Power supply circuit breaker tripped or fuse blown. 3. Motor wires connected incorrectly. 4. Wiring open/has high resistance. 5. ON/OFF switch at fault. 6. Start capacitor at fault. 7. Thermal overload relay has tripped. 8. Contactor not energized/has poor contacts. 9. Centrifugal switch at fault. 10. Motor at fault. 	<ol style="list-style-type: none"> 1. Ensure correct power supply voltage and circuit size. 2. Ensure circuit is sized correctly and free of shorts. Reset circuit breaker or replace fuse. 3. Correct motor wiring connections. 4. Check/fix broken, disconnected, or corroded wires. 5. Replace switch. 6. Test/replace. 7. Reset; adjust trip load dial if necessary; replace. 8. Test all legs for power/replace. 9. Adjust/replace centrifugal switch if available. 10. Test/repair/replace.
Machine stalls or is underpowered.	<ol style="list-style-type: none"> 1. Machine undersized for task. 2. Motor wired incorrectly. 3. Motor overheated. 4. Run capacitor at fault. 5. Contactor not energized/has poor contacts. 6. Motor at fault. 	<ol style="list-style-type: none"> 1. Clean/replace sandpaper; reduce feed rate/sanding depth. 2. Wire motor correctly. 3. Clean motor, let cool, and reduce workload. 4. Test/repair/replace. 5. Test all legs for power/replace. 6. Test/repair/replace.
Machine has vibration or noisy operation.	<ol style="list-style-type: none"> 1. Workpiece loose or incorrectly secured. 2. Table or switch pedestal mounting bolts loose. 3. Table contacting sanding disc. 4. Motor or component loose. 5. Motor fan rubbing on fan cover. 6. Motor mount loose/broken. 7. Machine incorrectly mounted. 8. Motor bearings at fault. 9. Sanding disc out of balance or loose. 10. Centrifugal switch is at fault. 	<ol style="list-style-type: none"> 1. Use correct holding fixture and reclamp workpiece. 2. Tighten mounting bolts. 3. Adjust table gap (Page 26). 4. Inspect/replace damaged bolts/nuts, and retighten with thread locking fluid. 5. Fix/replace fan cover; replace loose/damaged fan. 6. Tighten/replace. 7. Tighten mounting bolts; relocate/shim machine. 8. Test by rotating shaft; rotational grinding/loose shaft requires bearing replacement. 9. Tighten disc hub or replace disc. 10. Replace.
Motor takes longer than 4 seconds to stop sanding disc.	<ol style="list-style-type: none"> 1. Motor brake components at fault. 	<ol style="list-style-type: none"> 1. Replace motor brake components. Call Tech Support if you need assistance.



Sander Operation

Symptom	Possible Cause	Possible Solution
Miter bar binds in miter slot.	1. Miter slot dirty or gummed up.	1. Carefully clean miter slot.
Workpiece angle incorrect or out of square.	1. Pointer or scale not calibrated correctly. Miter gauge or table not correctly aligned.	1. Adjust pointer or scale to reflect real path of cut (Page 26, 27).
Sandpaper clogs quickly or burns.	1. Sandpaper grit is too fine for the job. 2. Workpiece is too moist. 3. Sanding pressure/depth too aggressive. 4. Paint, varnish, pitch, or other coating is loading up sandpaper. 5. Sanding soft workpiece. 6. Work held still for too long.	1. Replace with a coarser grit sandpaper. 2. Allow workpiece to dry out. 3. Reduce sanding pressure/depth or install coarser sandpaper. 4. Install a coarse grit sandpaper, or strip coating off before sanding. 5. Use different stock. Or, accept the characteristics of the stock and plan on cleaning/replacing discs frequently. 6. Move workpiece more frequently.
Glossy spots, burning, or streaks on workpiece.	1. Sandpaper too fine for the desired finish. 2. Work held still for too long. 3. Workpiece is too moist. 4. Sanding stock with high residue. 5. Worn sandpaper. 6. Sanding depth too aggressive.	1. Use a coarser grit sandpaper. 2. Do not keep workpiece in one place for too long. 3. Allow workpiece to dry out. 4. Use different stock. Or, accept the characteristics of the stock and plan on cleaning/replacing sandpapers frequently. 5. Replace sandpaper (Page 18). 6. Reduce sanding depth or install coarser sandpaper.
Abrasive rubs off the disc easily.	1. Sandpaper has been stored in an incorrect environment.	1. Replace; store sandpaper away from extremely dry, hot, or damp conditions.



Table Gap & Parallelism

The miter slot must be parallel with the face of the sanding disc. There should be a $\frac{1}{16}$ " gap between the edge of the table and sanding disc to prevent the sandpaper from rubbing against the table, and to reduce risk of fingers getting pinched.

Tools Needed:

Open-End Wrench 13mm..... 1
Ruler..... 1

To set table gap and parallelism:

1. DISCONNECT MACHINE FROM POWER!
2. Remove guard, then loosen the six hex bolts that secure table to table support brackets.
3. Adjust table so there is a $\frac{1}{16}$ " gap (see **Figure 24**) between disc (with sandpaper installed) and edge of table along its full length.

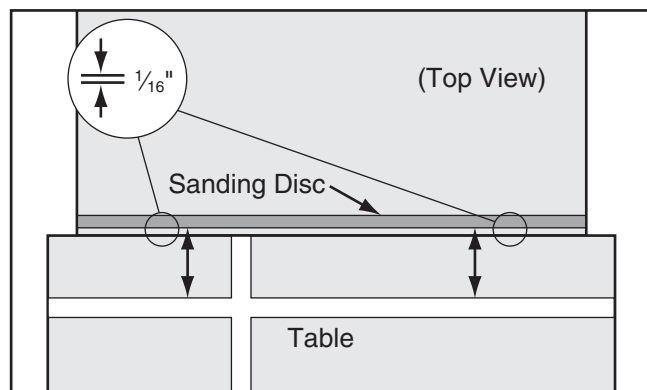

Figure 24. Table parallel with sanding disc.

4. When miter slot is parallel with sanding disc, tighten hex bolts.
5. Spin disc by hand to check if sandpaper touches table.

IMPORTANT: *DO NOT turn the disc sander ON until you have verified that it does not touch the table at any point in its rotation!*

— If sandpaper touches table at any point, re-adjust table parallelism.

6. Re-install guard.

Calibrating Miter Gauge

At 90° , the miter gauge should be perpendicular to the face of the disc when it is mounted in the X-axis table slot. If it is not, follow this procedure to recalibrate it.

Tools Needed:

90° Square Square..... 1
Phillips Head Screwdriver..... 1

To calibrate miter gauge:

1. DISCONNECT MACHINE FROM POWER!
2. Check that miter slot is parallel to sanding disc as described in **Table Gap & Parallelism**.
3. Set one edge of a try square or 90° square against face of miter gauge and other edge against disc face, as shown in **Figure 25**.

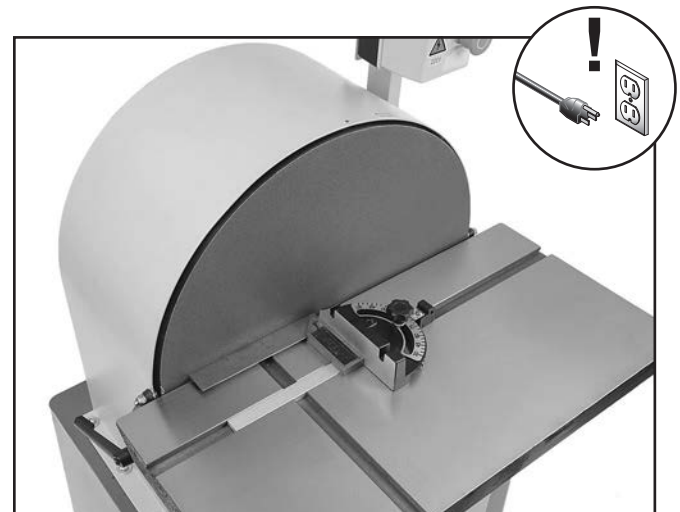

Figure 25. Squaring miter gauge to disc.

4. Loosen lock knob on miter gauge and adjust face of miter gauge so it is flush with edge of square, tighten gauge lock knob, and verify setting.
5. Loosen degree scale pointer, position pointer on 90° , and retighten screw.
6. Recheck miter scale accuracy with square.



Table Tilt Calibration

When the table is perpendicular to the sanding disc, the scale should read 0°. If not, follow this procedure.

Tools Needed:

90° Square	1
45° Square	1
Phillips Head Screwdriver.....	1
Hex Wrench 5mm.....	1

Calibrating Table Tilt

1. DISCONNECT MACHINE FROM POWER!
2. Set one edge of a try square or 90° square on table surface and the other edge against face of disc, as shown in **Figure 26**.

Note: Although this can be done with the sandpaper installed, it is more precise without it.

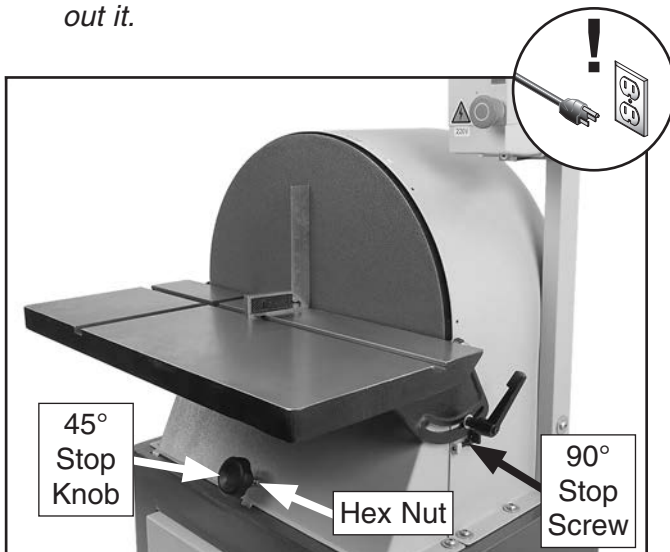

Figure 26. Squaring table.

3. Loosen lock handles, then adjust 90° stop screw (see **Figure 26**) until table angle is perfectly perpendicular to disc.
4. Tighten lock handles while holding table in place.

5. Loosen degree scale pointer screw (see **Figure 27**), adjust pointer to 0°, then retighten screw.



Figure 27. Scale pointer screw location.

6. Recheck scale accuracy with square.

Calibrating 45° Stop

1. DISCONNECT MACHINE FROM POWER!
2. Loosen lock handles and allow table to rest on 45° stop knob.
3. Set one edge of a 45° square on table surface and other edge against face of disc.
4. Adjust 45° stop knob (shown in **Figure 26**) until table angle is exactly 45° to disc, then tighten hex nut under 45° stop knob against sander frame.



SECTION 8: WIRING

These pages are current at the time of printing. However, in the spirit of improvement, we may make changes to the electrical systems of future machines. Compare the manufacture date of your machine to the one stated in this manual, and study this section carefully.

If there are differences between your machine and what is shown in this section, call Technical Support at (570) 546-9663 for assistance BEFORE making any changes to the wiring on your machine. An updated wiring diagram may be available. **Note:** *Please gather the serial number and manufacture date of your machine before calling. This information can be found on the main machine label.*

WARNING

Wiring Safety Instructions

SHOCK HAZARD. Working on wiring that is connected to a power source is extremely dangerous. Touching electrified parts will result in personal injury including but not limited to severe burns, electrocution, or death. Disconnect the power from the machine before servicing electrical components!

MODIFICATIONS. Modifying the wiring beyond what is shown in the diagram may lead to unpredictable results, including serious injury or fire. This includes the installation of unapproved after-market parts.

WIRE CONNECTIONS. All connections must be tight to prevent wires from loosening during machine operation. Double-check all wires disconnected or connected during any wiring task to ensure tight connections.

CIRCUIT REQUIREMENTS. You MUST follow the requirements at the beginning of this manual when connecting your machine to a power source.

WIRE/COMPONENT DAMAGE. Damaged wires or components increase the risk of serious personal injury, fire, or machine damage. If you notice that any wires or components are damaged while performing a wiring task, replace those wires or components.

MOTOR WIRING. The motor wiring shown in these diagrams is current at the time of printing but may not match your machine. If you find this to be the case, use the wiring diagram inside the motor junction box.















CAPACITORS/INVERTERS. Some capacitors and power inverters store an electrical charge for up to 10 minutes after being disconnected from the power source. To reduce the risk of being shocked, wait at least this long before working on capacitors.

EXPERIENCING DIFFICULTIES. If you are experiencing difficulties understanding the information included in this section, contact our Technical Support at (570) 546-9663.

NOTICE

The photos and diagrams included in this section are best viewed in color. You can view these pages in color at www.grizzly.com.

COLOR KEY

BLACK		BLUE		YELLOW		LIGHT BLUE	
WHITE		BROWN		YELLOW GREEN		BLUE WHITE	
GREEN		GRAY		PURPLE		TURQUOISE	
RED		ORANGE		PINK			



Electrical Components

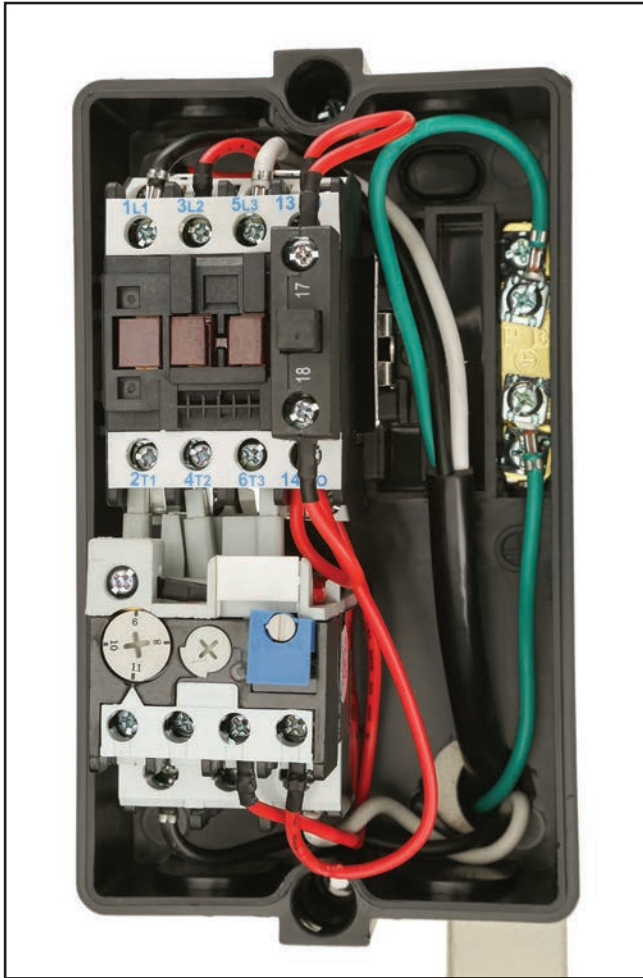

Figure 28. Magnetic switch.



Figure 29. Start capacitor.

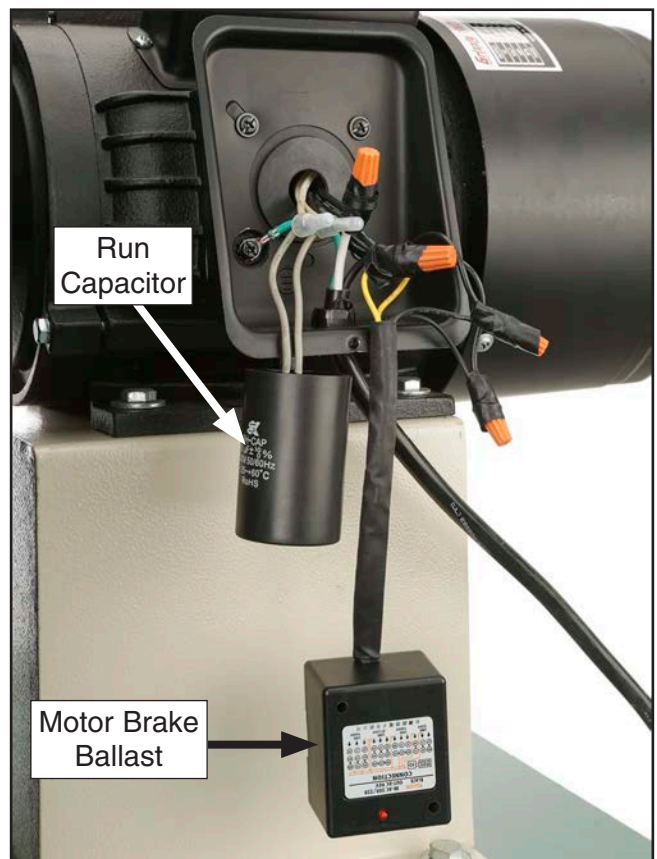
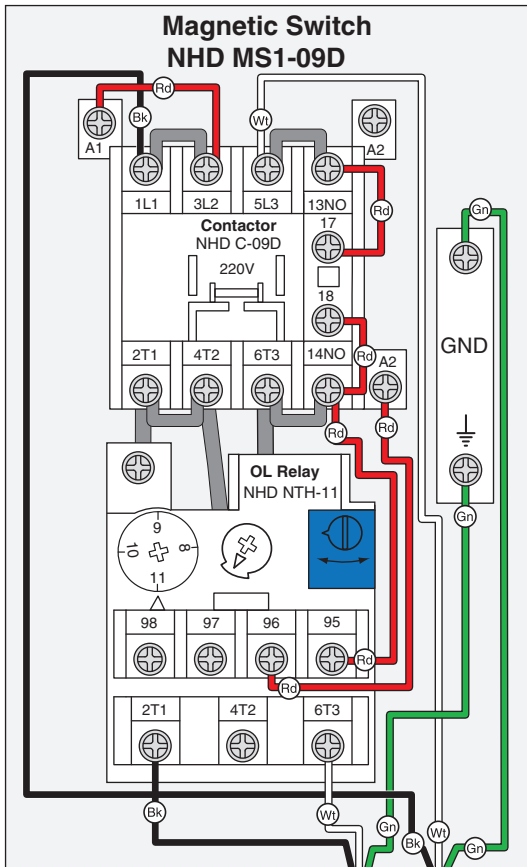

Figure 30. Motor junction box components.

Wiring Diagram





⚠ WARNING!

SHOCK HAZARD!
Disconnect power before working on wiring.



NOTICE

The motor wiring shown here is current at the time of printing, but it may not match your machine. Always use the wiring diagram inside the motor junction box.

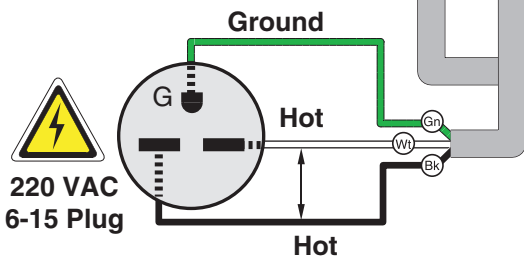
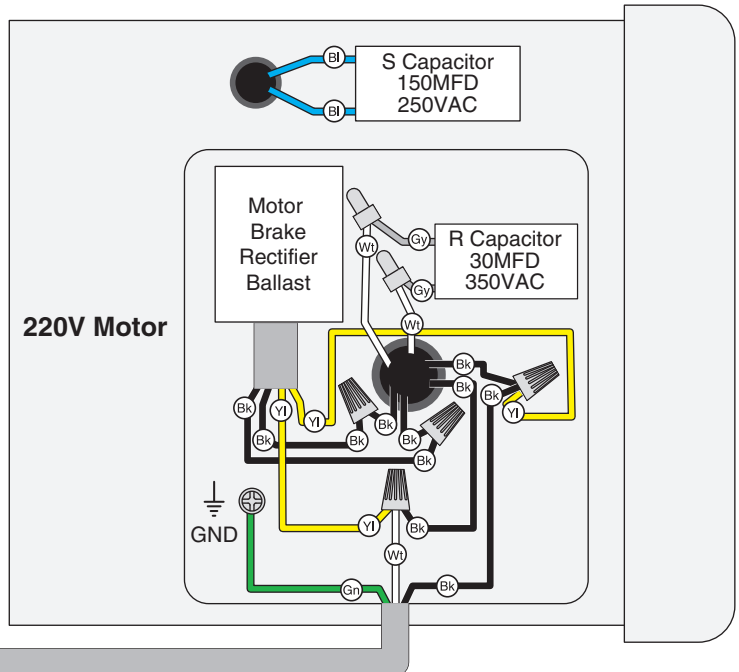

SECTION 9: PARTS

Main Breakdown

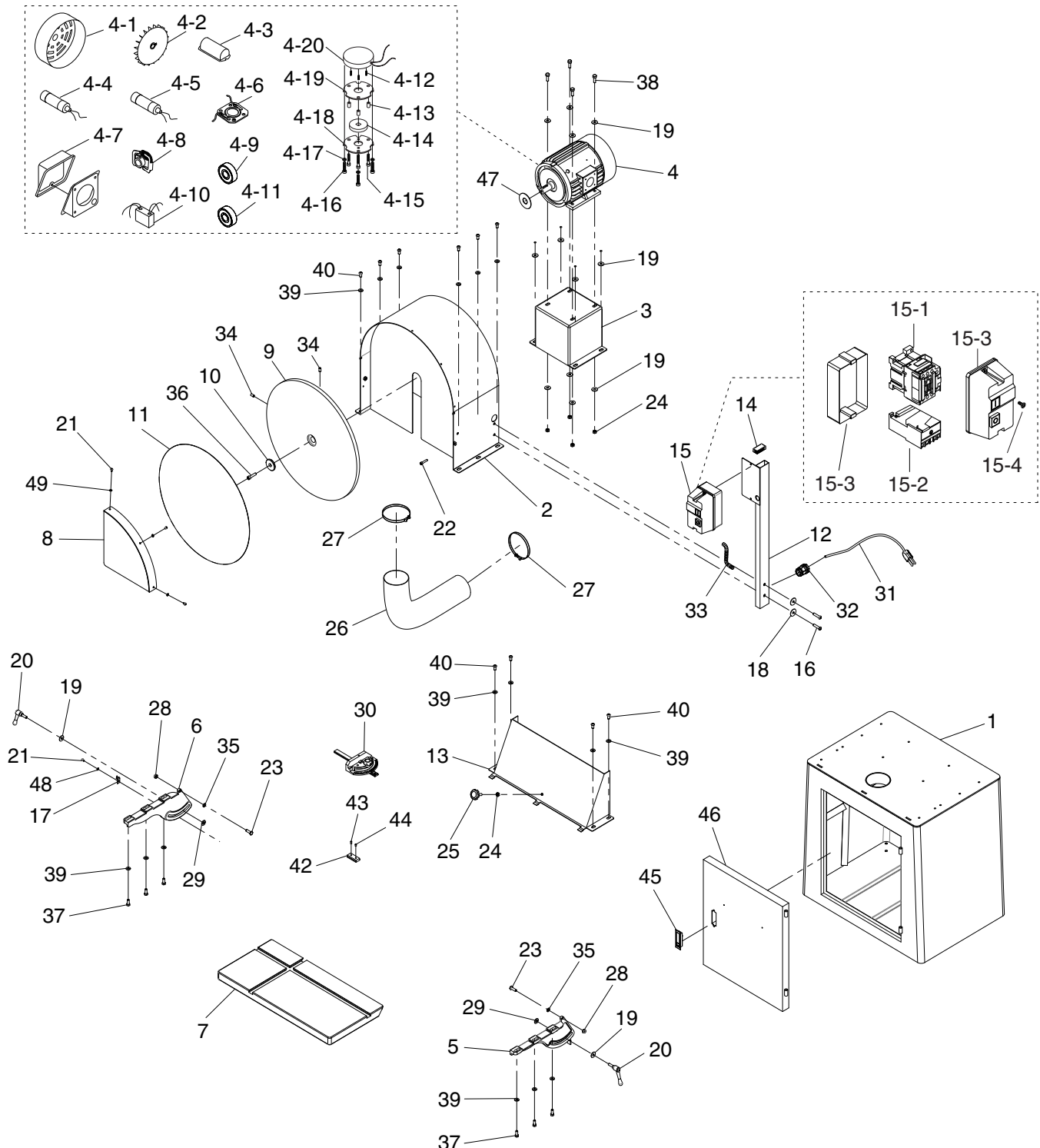

Please Note: We do our best to stock replacement parts whenever possible, but we cannot guarantee that all parts shown here are available for purchase. Call (800) 523-4777 or visit our online parts store at www.grizzly.com to check for availability.

Model G0775 (Mfd. Since 11/14)



Main Parts List

REF	PART #	DESCRIPTION
1	P0775001	BASE
2	P0775002	DISC COVER
3	P0775003	MOTOR BASE
4	P0775004	MOTOR 2HP 220V 1-PH
4-1	P0775004-1	MOTOR FAN COVER
4-2	P0775004-2	MOTOR FAN
4-3	P0775004-3	CAPACITOR COVER
4-4	P0775004-4	S CAPACITOR 150M 250V 1-3/4 X 3-1/2
4-5	P0775004-5	R CAPACITOR 30M 350V 1-1/2 X 2-1/2
4-6	P0775004-6	CONTACT PLATE
4-7	P0775004-7	MOTOR JUNCTION BOX
4-8	P0775004-8	CENTRIFUGAL SWITCH
4-9	P0775004-9	BALL BEARING 6203ZZ
4-10	P0775004-10	REGULATOR SWITCH
4-11	P0775004-11	BALL BEARING 6204ZZ
4-12	P0775004-12	COMPRESSION SPRING
4-13	P0775004-13	SPACER
4-14	P0775004-14	BRAKE PAD
4-15	P0775004-15	SHOULDER SCREW M5-.8 X 25, 8 X 35 BLK
4-16	P0775004-16	CAP SCREW M6-1 X 30 SS
4-17	P0775004-17	FLAT WASHER 6MM
4-18	P0775004-18	OUTSIDE PLATE
4-19	P0775004-19	INSIDE PLATE
4-20	P0775004-20	MOTOR BRAKE MCN CB-08-CS DC-90V
5	P0775005	TABLE BRACKET (R)
6	P0775006	TABLE BRACKET (L)
7	P0775007	TABLE
8	P0775008	DISC GUARD
9	P0775009	DISC PLATEN 20"
10	P0775010	FLANGE WASHER 8MM
11	P0775011	SANDING DISC 20" 100-GRIT PSA
12	P0775012	SWITCH PEDESTAL
13	P0775013	DUST COLLECTION HOOD
14	P0775014	PLASTIC CAP 50 X 25MM
15	P0775015	MAG SWITCH ASSY NHD MS1-09D
15-1	P0775015-1	CONTACTOR NHD C-09D

REF	PART #	DESCRIPTION
15-2	P0775015-2	OL RELAY NHD NTH-11 8-11A
15-3	P0775015-3	MAG SWITCH COVER ASSY
15-4	P0775015-4	MAG SWITCH COVER SCREW
16	P0775016	BUTTON HD CAP SCR M8-1.25 X 35
17	P0775017	POINTER
18	P0775018	FENDER WASHER 8MM
19	P0775019	FLAT WASHER 8MM
20	P0775020	ADJUSTABLE HANDLE M8-1.25 X 25
21	P0775021	PHLP HD SCR M5-.8 X 8
22	P0775022	CAP SCREW M6-1 X 30
23	P0775023	BUTTON HD CAP SCR M8-1.25 X 25
24	P0775024	HEX NUT M8-1.25
25	P0775025	KNOB M8-1.25 X 40
26	P0775026	FLEXIBLE HOSE 4" X 22-7/8"
27	P0775027	HOSE CLAMP 4"
28	P0775028	LOCK NUT M8-1.25
29	P0775029	FLAT WASHER 8MM PLASTIC
30	P0775030	MITER GAUGE ASSY
31	P0775031	POWER CORD 14G 3W 72" 6-15P
32	P0775032	STRAIN RELIEF 5/16"-3/8" 90D PLASTIC
33	P0775033	MOTOR CORD 14G 3W 25"
34	P0775034	SET SCREW M8-1.25 X 15
35	P0775035	LOCK WASHER 8MM
36	P0775036	CAP SCREW M8-1.25 X 35
37	P0775037	HEX BOLT M8-1.25 X 20
38	P0775038	HEX BOLT M8-1.25 X 25
39	P0775039	FLAT WASHER 8MM
40	P0775040	BUTTON HD CAP SCR M8-1.25 X 16
42	P0775042	RADIUS SANDING ATTACHMENT
43	P0775043	SET SCREW M5-.8 X 10 CONE-PT
44	P0775044	SET SCREW M5-.8 X 8 DOG-PT
45	P0775045	DOOR LATCH
46	P0775046	DOOR
47	P0775047	FLAT WASHER 30 X 65MM RUBBER
48	P0775048	FLAT WASHER #10
49	P0775049	EXT TOOTH WASHER 5MM



Labels and Cosmetics

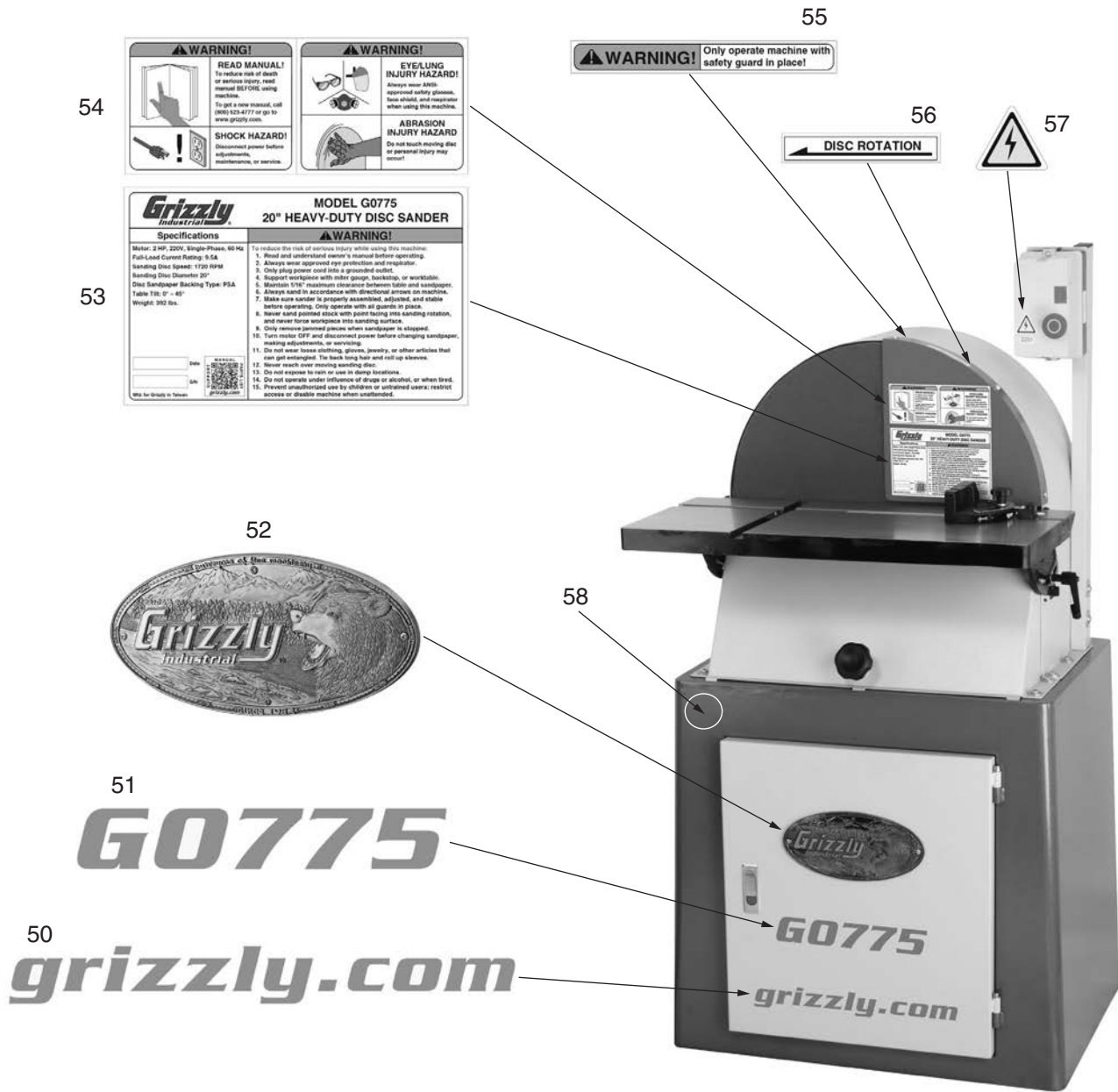

REF	PART #	DESCRIPTION
50	P0775050	GRIZZLY.COM LABEL
51	P0775051	MODEL NUMBER LABEL
52	P0775052	GRIZZLY NAMEPLATE SMALL G8588
53	P0775053	MACHINE ID LABEL

REF	PART #	DESCRIPTION
55	P0775055	SAFETY GUARD WARNING LABEL
56	P0775056	ROTATION WARNING LABEL
57	P0775057	ELECTRICITY LABEL
58	P0775058	GRIZZLY GREEN TOUCH-UP PAINT

⚠ WARNING

Safety labels help reduce the risk of serious injury caused by machine hazards. If any label comes off or becomes unreadable, the owner of this machine **MUST** replace it in the original location before resuming operations. For replacements, contact (800) 523-4777 or www.grizzly.com.





WARRANTY CARD

Name _____
 Street _____
 City _____ State _____ Zip _____
 Phone # _____ Email _____
 Model # _____ Order # _____ Serial # _____

The following information is given on a voluntary basis. It will be used for marketing purposes to help us develop better products and services. **Of course, all information is strictly confidential.**

1. How did you learn about us?

Advertisement Friend Catalog
 Card Deck Website Other:

2. Which of the following magazines do you subscribe to?

<input type="checkbox"/> Cabinetmaker & FDM	<input type="checkbox"/> Popular Science	<input type="checkbox"/> Wooden Boat
<input type="checkbox"/> Family Handyman	<input type="checkbox"/> Popular Woodworking	<input type="checkbox"/> Woodshop News
<input type="checkbox"/> Hand Loader	<input type="checkbox"/> Precision Shooter	<input type="checkbox"/> Woodsmith
<input type="checkbox"/> Handy	<input type="checkbox"/> Projects in Metal	<input type="checkbox"/> Woodwork
<input type="checkbox"/> Home Shop Machinist	<input type="checkbox"/> RC Modeler	<input type="checkbox"/> Woodworker West
<input type="checkbox"/> Journal of Light Cont.	<input type="checkbox"/> Rifle	<input type="checkbox"/> Woodworker's Journal
<input type="checkbox"/> Live Steam	<input type="checkbox"/> Shop Notes	<input type="checkbox"/> Other:
<input type="checkbox"/> Model Airplane News	<input type="checkbox"/> Shotgun News	
<input type="checkbox"/> Old House Journal	<input type="checkbox"/> Today's Homeowner	
<input type="checkbox"/> Popular Mechanics	<input type="checkbox"/> Wood	

3. What is your annual household income?

\$20,000-\$29,000 \$30,000-\$39,000 \$40,000-\$49,000
 \$50,000-\$59,000 \$60,000-\$69,000 \$70,000+

4. What is your age group?

20-29 30-39 40-49
 50-59 60-69 70+

5. How long have you been a woodworker/metalworker?

0-2 Years 2-8 Years 8-20 Years 20+ Years

6. How many of your machines or tools are Grizzly?

0-2 3-5 6-9 10+

7. Do you think your machine represents a good value? Yes No

8. Would you recommend Grizzly Industrial to a friend? Yes No

9. Would you allow us to use your name as a reference for Grizzly customers in your area?
Note: We never use names more than 3 times. Yes No

10. Comments: _____

CUT ALONG DOTTED LINE

FOLD ALONG DOTTED LINE



Place
Stamp
Here



GRIZZLY INDUSTRIAL, INC.
P.O. BOX 2069
BELLINGHAM, WA 98227-2069



FOLD ALONG DOTTED LINE

Send a Grizzly Catalog to a friend:

Name _____
Street _____
City _____ State _____ Zip _____

TAPE ALONG EDGES--PLEASE DO NOT STAPLE

WARRANTY & RETURNS

Grizzly Industrial, Inc. warrants every product it sells for a period of **1 year** to the original purchaser from the date of purchase. This warranty does not apply to defects due directly or indirectly to misuse, abuse, negligence, accidents, repairs or alterations or lack of maintenance. This is Grizzly's sole written warranty and any and all warranties that may be implied by law, including any merchantability or fitness, for any particular purpose, are hereby limited to the duration of this written warranty. We do not warrant or represent that the merchandise complies with the provisions of any law or acts unless the manufacturer so warrants. In no event shall Grizzly's liability under this warranty exceed the purchase price paid for the product and any legal actions brought against Grizzly shall be tried in the State of Washington, County of Whatcom.

We shall in no event be liable for death, injuries to persons or property or for incidental, contingent, special, or consequential damages arising from the use of our products.

To take advantage of this warranty, contact us by mail or phone and give us all the details. We will then issue you a "Return Number," which must be clearly posted on the outside as well as the inside of the carton. We will not accept any item back without this number. Proof of purchase must accompany the merchandise.

The manufacturers reserve the right to change specifications at any time because they constantly strive to achieve better quality equipment. We make every effort to ensure that our products meet high quality and durability standards and we hope you never need to use this warranty.

Please feel free to write or call us if you have any questions about the machine or the manual.

Thank you again for your business and continued support. We hope to serve you again soon.

grizzly.com[®]

TOOL WEBSITE

Buy Direct and Save with Grizzly[®] – Trusted, Proven and a Great Value!
~Since 1983~

*Visit Our Website Today For
Current Specials!*

**ORDER
24 HOURS A DAY!
1-800-523-4777**



Free Manuals Download Website

<http://myh66.com>

<http://usermanuals.us>

<http://www.somanuals.com>

<http://www.4manuals.cc>

<http://www.manual-lib.com>

<http://www.404manual.com>

<http://www.luxmanual.com>

<http://aubethermostatmanual.com>

Golf course search by state

<http://golfingnear.com>

Email search by domain

<http://emailbydomain.com>

Auto manuals search

<http://auto.somanuals.com>

TV manuals search

<http://tv.somanuals.com>