

Grizzly **Industrial, Inc.**®

MODEL G0756 **INDUSTRIAL DRILL PRESS**

OWNER'S MANUAL

(For models manufactured since 03/13)



COPYRIGHT © MAY, 2013 BY GRIZZLY INDUSTRIAL, INC.,
**WARNING: NO PORTION OF THIS MANUAL MAY BE REPRODUCED IN ANY SHAPE
OR FORM WITHOUT THE WRITTEN APPROVAL OF GRIZZLY INDUSTRIAL, INC.**
#DM15670 PRINTED IN CHINA

 **WARNING!**

This manual provides critical safety instructions on the proper setup, operation, maintenance, and service of this machine/tool. Save this document, refer to it often, and use it to instruct other operators.

Failure to read, understand and follow the instructions in this manual may result in fire or serious personal injury—including amputation, electrocution, or death.

The owner of this machine/tool is solely responsible for its safe use. This responsibility includes but is not limited to proper installation in a safe environment, personnel training and usage authorization, proper inspection and maintenance, manual availability and comprehension, application of safety devices, cutting/sanding/grinding tool integrity, and the usage of personal protective equipment.

The manufacturer will not be held liable for injury or property damage from negligence, improper training, machine modifications or misuse.

 **WARNING!**

Some dust created by power sanding, sawing, grinding, drilling, and other construction activities contains chemicals known to the State of California to cause cancer, birth defects or other reproductive harm. Some examples of these chemicals are:

- **Lead from lead-based paints.**
- **Crystalline silica from bricks, cement and other masonry products.**
- **Arsenic and chromium from chemically-treated lumber.**

Your risk from these exposures varies, depending on how often you do this type of work. To reduce your exposure to these chemicals: Work in a well ventilated area, and work with approved safety equipment, such as those dust masks that are specially designed to filter out microscopic particles.

Table of Contents

INTRODUCTION	2	SECTION 6: MAINTENANCE	32
Machine Description	2	Schedule	32
Contact Info.....	2	Ongoing	32
Manual Accuracy	2	Daily, After Operations.....	32
Identification.....	3	Annually	32
Control Panel	4	Cleaning and Protecting	32
Machine Data Sheet	5	Lubrication	33
SECTION 1: SAFETY	7	Headstock Lubrication	33
Safety Instructions for Machinery	7	Ball Oilers.....	34
Safety for Drill Presses	9	Changing Coolant	34
SECTION 2: POWER SUPPLY	10	SECTION 7: SERVICE	35
Availability	10	Troubleshooting	35
Full-Load Current Rating	10	Motor & Electrical.....	35
Circuit Requirements for 220V.....	10	Drill Press Operations.....	36
Grounding Instructions.....	11	Replacing Lamp Bulb.....	37
Extension Cords.....	11	Torque Limiter.....	37
SECTION 3: SETUP	12	SECTION 8: WIRING	38
Unpacking	12	Wiring Safety Instructions	38
Needed for Setup.....	12	Wiring Overview	39
Inventory	12	Component Location Index.....	39
Cleanup.....	13	Power Connection Wiring	40
Site Considerations.....	14	Electric Clutch Wiring.....	40
Lifting & Placing	15	Motor & Pump Wiring	41
Anchoring to Floor	15	Control Panel	42
Anchoring to Concrete Floors	15	Control Panel & Limit Switches	43
Arbor/Chuck Assembly	16	Electrical Panel Wiring.....	44
Initial Lubrication.....	16	Electrical Wiring Panel Photo	45
Power Connection.....	17	SECTION 9: PARTS	46
Test Run	18	Table Support & Coolant Breakdown	46
Coolant System.....	20	Gearbox Breakdown	48
Spindle Break-In	21	Gearbox Breakdown 2	49
SECTION 4: OPERATIONS	22	Spindle Feed Breakdown.....	51
Operations Overview	22	Headstock Breakdown	53
Tooling Installation & Removal	22	Headstock Breakdown 2.....	54
Installing Tapered Tooling	23	Electrical Parts Breakdown.....	56
Removing Tooling with Automatic Drift.....	23	Labels & Cosmetics	58
Removing Tooling Manually	23	WARRANTY & RETURNS	61
Depth Stop.....	24		
Table Positioning	24		
Raising/Lowering Table	24		
Rotating Table.....	24		
Selecting Spindle RPM.....	25		
Drilling Mode	26		
Automatic Power Downfeed	27		
Tapping Mode.....	28		
Coolant System.....	28		
SECTION 5: ACCESSORIES	29		

INTRODUCTION

Machine Description

We are proud to offer the Model G0756 18-speed Heavy-Duty Drill Press. When used according to the guidelines set forth in this manual, you can expect years of trouble-free, enjoyable operation and proof of Grizzly's commitment to customer satisfaction.

This drill press features power tapping with an electronic clutch and activation buttons on the downfeed handles. Spindle speed is adjustable through the use of the levers above the main control panel. The pump-controlled coolant system helps provide optimum working results and extended longevity of tooling.

Contact Info

We stand behind our machines. If you have any questions or need help, use the information below to contact us. Before contacting, please get the serial number and manufacture date of your machine. This will help us help you faster.

Grizzly Technical Support
1203 Lycoming Mall Circle
Muncy, PA 17756
Phone: (570) 546-9663
Email: techsupport@grizzly.com

We want your feedback on this manual. What did you like about it? Where could it be improved? Please take a few minutes to give us feedback.

Grizzly Documentation Manager
P.O. Box 2069
Bellingham, WA 98227-2069
Email: manuals@grizzly.com

Manual Accuracy

We are proud to provide a high-quality owner's manual with your new machine!

We made every effort to be exact with the instructions, specifications, drawings, and photographs contained inside. Sometimes we make mistakes, but our policy of continuous improvement also means that **sometimes the machine you receive will be slightly different than what is shown in the manual.**

If you find this to be the case, and the difference between the manual and machine leaves you confused about a procedure, check our website for an updated version. We post current manuals and manual updates for free on our website at www.grizzly.com.

Alternatively, you can call our Technical Support for help. Before calling, please write down the **Manufacture Date** and **Serial Number** stamped into the machine ID label (see below). This information helps us determine if updated documentation is available for your machine.

		MODEL GXXXX	
		MACHINE NAME	
SPECIFICATIONS		▲ WARNING!	
Motor:		To reduce risk of serious injury when using this machine:	
Specification:		1. Read manual before operation.	
Specification:		2. Wear safety glasses and respirator.	
Specification:		3. Make sure machine is properly adjusted/setup and	
Specification:		4. Make sure the motor has stopped and disconnect power before adjustments, maintenance, or service.	
Weight:		5. DO NOT expose to rain or dampness.	
		6. DO NOT modify this machine in any way.	
		7.	
		8.	
		9.	
		10. Maintain machine carefully to prevent accidents.	

Manufactured for Grizzly in Taiwan

Manufacture Date

Serial Number



Identification

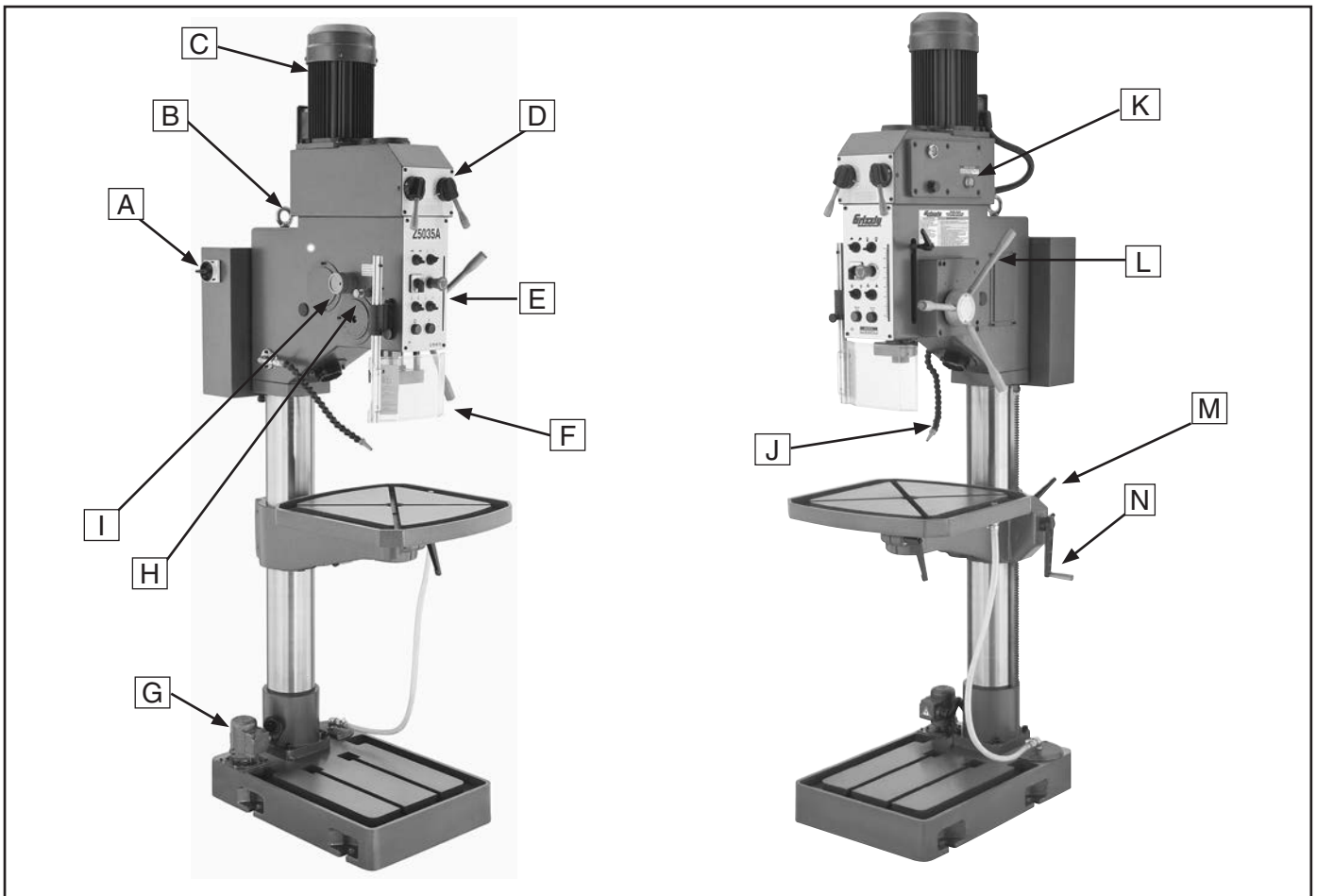

- A. Main Power Switch
- B. Lifting Eye Bolt
- C. Motor
- D. Speed Control Levers
- E. Control Panel (see **Page 4** for details)
- F. Chip Guard
- G. Coolant Pump
- H. Automatic Drift
- I. Automatic Downfeed Adjustment Knob
- J. Coolant Nozzle
- K. Oil Site Glass
- L. Coarse Downfeed Handles
- M. Table Lock Handles
- N. Table Height Adjustment Crank



Control Panel

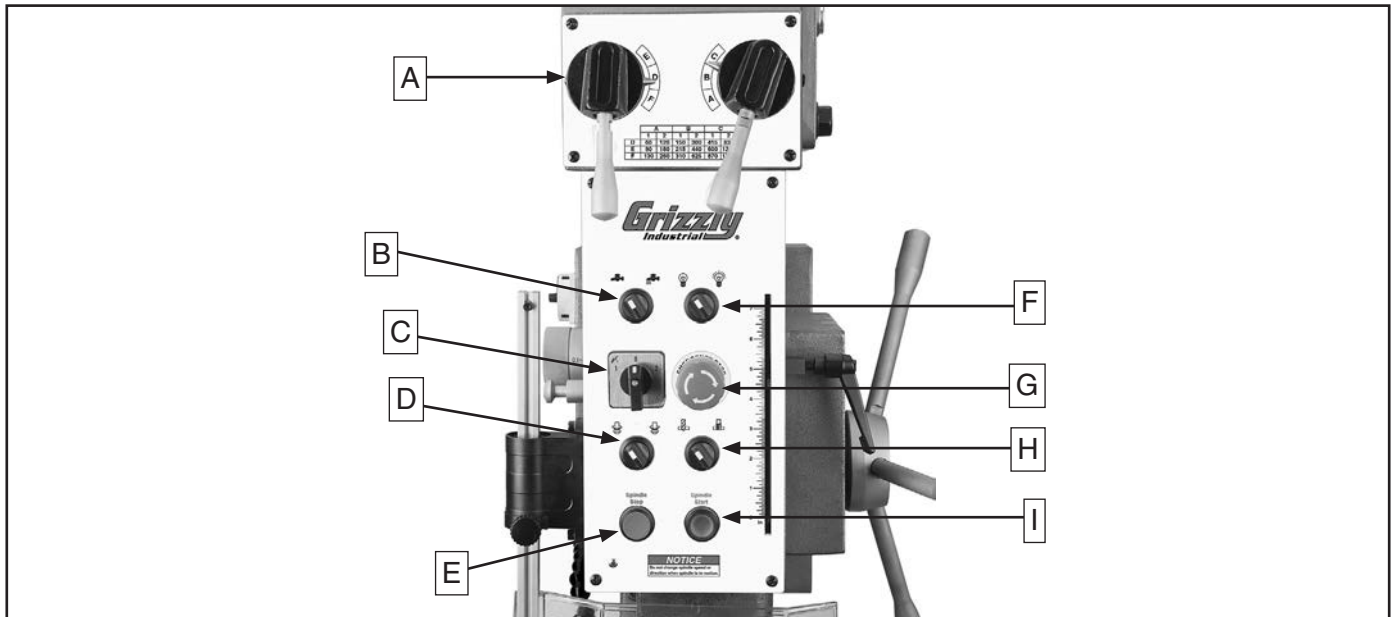

Figure 1. Control panel

- A. Spindle Speed Levers:** Used to get spindle speed at available RPMs.
- B. Coolant Pump Switch:** Turns pump on, sending coolant to nozzle
- C. High/Low Spindle Speed Range Switch:** Selects high/low range for spindle speed.
- D. Spindle Rotation Switch:** Controls direction.
- E. Spindle Stop Button:** Stops all work.
- F. Working Lamp Switch:** Turns work light on or off.
- G. EMERGENCY STOP Button:** Immediately cuts power to motor and control panel when pressed. Remains depressed until button is reset by twisting clockwise.
- H. Drilling/Tapping Switch:** Selects between drilling and tapping modes.
- I. Spindle Start Button:** Starts machine when Master Power Switch has already been turned to the ON position and the high/low spindle speed range switch is turned to 1 or 2.





MACHINE DATA SHEET

Customer Service #: (570) 546-9663 · To Order Call: (800) 523-4777 · Fax #: (800) 438-5901

MODEL G0756 HEAVY-DUTY DRILLING MACHINE

Product Dimensions:

Weight..... 1026 lbs.
 Width (side-to-side) x Depth (front-to-back) x Height..... 22 x 37 x 89-1/2 in.
 Footprint (Length x Width)..... 29 x 20 in.

Shipping Dimensions:

Type..... Wood Crate
 Content..... Machine
 Weight..... 1202 lbs.
 Length x Width x Height..... 90 x 28 x 45 in.
 Must Ship Upright..... No

Electrical:

Power Requirement..... 220V, 3-Phase, 60 Hz
 Prewired Voltage..... 220V
 Full-Load Current Rating..... 6.6A
 Minimum Circuit Size..... 15A
 Connection Type..... Cord & Plug
 Power Cord Included..... No
 Recommended Power Cord..... "S"-Type, 4-Wire, 14 AWG, 300 VAC
 Plug Included..... No
 Recommended Plug Type..... 15-15
 Switch Type..... Magnetic Switch w/Overload Protection
 Recommended Phase Converter..... G5844

Motors:

Coolant Pump

Type..... Universal
 Horsepower..... 60W
 Phase..... 3-Phase
 Amps..... 0.2A
 Speed..... 1725 RPM
 Power Transfer..... Direct Drive
 Bearings..... Shielded & Permanently Lubricated

Main

Type..... TEFC Induction
 Horsepower..... 1-1/8 HP / 2 HP
 Phase..... 3-Phase
 Amps..... 6.4A
 Speed..... 875 / 1725 RPM
 Power Transfer..... Gear Drive
 Bearings..... Shielded & Permanently Lubricated



Main Specifications:

Operation Info

Spindle Travel.....	7 in.
Max Distance Spindle to Column.....	13-3/4 in.
Max Distance Spindle to Table.....	30-3/4 in.
Vertical Table Travel (Z-Axis).....	20 in.
Table Swivel (Left/Right).....	360 deg.
Drilling Capacity for Cast Iron.....	1-1/2 in.
Drilling Capacity for Steel.....	1-3/16 in.

Table Info

Table Length.....	22 in.
Table Width.....	22 in.
Table Thickness.....	1-7/8 in.
Number of T-Slots.....	2
T-Slot Size.....	9/16 in.
X/Y-Axis Travel per Handwheel Revolution.....	0.200 in.
Z-Axis Travel per Handwheel Revolution.....	0.100 in.

Spindle Info

Spindle Taper.....	MT#4
Number of Vertical Spindle Speeds.....	18
Range of Vertical Spindle Speeds.....	60 – 1740 RPM
Quill Diameter.....	3 in.
Quill Feed Rates.....	0.004, 0.008 in./rev.
Spindle Bearings.....	Tapered Roller Bearings

Construction

Spindle Housing/Quill.....	Cast Iron
Table.....	Precision-Ground Cast Iron
Head.....	Cast Iron
Column/Base.....	Precision-Ground Cast Iron
Base.....	Cast Iron
Paint.....	Enamel

Other Specifications:

Country Of Origin	China
Warranty	1 Year
Approximate Assembly & Setup Time	1 Hour
ISO 9001 Factory	Yes
CSA Certified	No

Features:

- 7" Spindle Travel
- Recycling Coolant System
- Power Tapping w/Electronic Clutch
- 2-Speed Power Downfeed
- Oil-Bath Gearhead w/Circulating Pump
- MT#4 Spindle w/Tool Quick-Removal Feature
- Spindle Speeds Controlled by Gearhead Levers
- Tapping Activation Buttons on Downfeed Handles
- Precision-Ground Table Base
- Spindle Safety Shield
- Halogen Work Light
- Precision-Ground Cast Iron Base Table, 21" x 19-3/4", w/Two 11/16" T-Slots



SECTION 1: SAFETY

For Your Own Safety, Read Instruction Manual Before Operating This Machine

The purpose of safety symbols is to attract your attention to possible hazardous conditions. This manual uses a series of symbols and signal words intended to convey the level of importance of the safety messages. The progression of symbols is described below. Remember that safety messages by themselves do not eliminate danger and are not a substitute for proper accident prevention measures. Always use common sense and good judgment.

⚠ DANGER Indicates an imminently hazardous situation which, if not avoided, **WILL** result in death or serious injury.

⚠ WARNING Indicates a potentially hazardous situation which, if not avoided, **COULD** result in death or serious injury.

⚠ CAUTION Indicates a potentially hazardous situation which, if not avoided, **MAY** result in minor or moderate injury. It may also be used to alert against unsafe practices.

NOTICE This symbol is used to alert the user to useful information about proper operation of the machine.

Safety Instructions for Machinery

⚠ WARNING

OWNER'S MANUAL. Read and understand this owner's manual **BEFORE** using machine.

TRAINED OPERATORS ONLY. Untrained operators have a higher risk of being hurt or killed. Only allow trained/supervised people to use this machine. When machine is not being used, disconnect power, remove switch keys, or lock-out machine to prevent unauthorized use—especially around children. Make workshop kid proof!

DANGEROUS ENVIRONMENTS. Do not use machinery in areas that are wet, cluttered, or have poor lighting. Operating machinery in these areas greatly increases the risk of accidents and injury.

MENTAL ALERTNESS REQUIRED. Full mental alertness is required for safe operation of machinery. Never operate under the influence of drugs or alcohol, when tired, or when distracted.

ELECTRICAL EQUIPMENT INJURY RISKS. You can be shocked, burned, or killed by touching live electrical components or improperly grounded machinery. To reduce this risk, only allow qualified service personnel to do electrical installation or repair work, and always disconnect power before accessing or exposing electrical equipment.

DISCONNECT POWER FIRST. Always disconnect machine from power supply **BEFORE** making adjustments, changing tooling, or servicing machine. This prevents an injury risk from unintended startup or contact with live electrical components.

EYE PROTECTION. Always wear ANSI-approved safety glasses or a face shield when operating or observing machinery to reduce the risk of eye injury or blindness from flying particles. Everyday eyeglasses are **NOT** approved safety glasses.



WARNING

WEARING PROPER APPAREL. Do not wear clothing, apparel or jewelry that can become entangled in moving parts. Always tie back or cover long hair. Wear non-slip footwear to avoid accidental slips, which could cause loss of workpiece control.

HAZARDOUS DUST. Dust created while using machinery may cause cancer, birth defects, or long-term respiratory damage. Be aware of dust hazards associated with each workpiece material, and always wear a NIOSH-approved respirator to reduce your risk.

HEARING PROTECTION. Always wear hearing protection when operating or observing loud machinery. Extended exposure to this noise without hearing protection can cause permanent hearing loss.

REMOVE ADJUSTING TOOLS. Tools left on machinery can become dangerous projectiles upon startup. Never leave chuck keys, wrenches, or any other tools on machine. Always verify removal before starting!

USE CORRECT TOOL FOR THE JOB. Only use this tool for its intended purpose—do not force it or an attachment to do a job for which it was not designed. Never make unapproved modifications—modifying tool or using it differently than intended may result in malfunction or mechanical failure that can lead to personal injury or death!

AWKWARD POSITIONS. Keep proper footing and balance at all times when operating machine. Do not overreach! Avoid awkward hand positions that make workpiece control difficult or increase the risk of accidental injury.

CHILDREN & BYSTANDERS. Keep children and bystanders at a safe distance from the work area. Stop using machine if they become a distraction.

GUARDS & COVERS. Guards and covers reduce accidental contact with moving parts or flying debris. Make sure they are properly installed, undamaged, and working correctly.

FORCING MACHINERY. Do not force machine. It will do the job safer and better at the rate for which it was designed.

NEVER STAND ON MACHINE. Serious injury may occur if machine is tipped or if the cutting tool is unintentionally contacted.

STABLE MACHINE. Unexpected movement during operation greatly increases risk of injury or loss of control. Before starting, verify machine is stable and mobile base (if used) is locked.

USE RECOMMENDED ACCESSORIES. Consult this owner's manual or the manufacturer for recommended accessories. Using improper accessories will increase the risk of serious injury.

UNATTENDED OPERATION. To reduce the risk of accidental injury, turn machine **OFF** and ensure all moving parts completely stop before walking away. Never leave machine running while unattended.

MAINTAIN WITH CARE. Follow all maintenance instructions and lubrication schedules to keep machine in good working condition. A machine that is improperly maintained could malfunction, leading to serious personal injury or death.

CHECK DAMAGED PARTS. Regularly inspect machine for any condition that may affect safe operation. Immediately repair or replace damaged or mis-adjusted parts before operating machine.

MAINTAIN POWER CORDS. When disconnecting cord-connected machines from power, grab and pull the plug—NOT the cord. Pulling the cord may damage the wires inside. Do not handle cord/plug with wet hands. Avoid cord damage by keeping it away from heated surfaces, high traffic areas, harsh chemicals, and wet/damp locations.

EXPERIENCING DIFFICULTIES. If at any time you experience difficulties performing the intended operation, stop using the machine! Contact our Technical Support at (570) 546-9663.



WARNING

Safety for Drill Presses

EYE/FACE/HAND PROTECTION. A face shield used with safety glasses is recommended. Always keep hands and fingers away from the drill bit. Never hold a workpiece by hand while drilling! **DO NOT** wear gloves when operating the drill.

SECURING BIT. Properly tighten and securely lock the drill bit in the chuck.

CORRECT BIT. Use only round, hex, or triangular shank drill bits.

ADJUSTING KEYS AND WRENCHES. Remove all adjusting keys and wrenches before turning the machine **ON**.

DRILLING SHEET METAL. Never drill sheet metal unless it is securely clamped to the table.

SURFACE/WORKPIECE PREP. Never turn the drill press **ON** before clearing the table of all objects (tools, scrap wood, etc.) **DO NOT** drill material that does not have a flat surface, unless a suitable support is used.

DAMAGED TOOLS. Never use drill bits in poor condition. Dull or damaged drill bits are hard to control and may cause serious injury.

DRILL OPERATION. Never start the drill press with the drill bit pressed against the workpiece. Feed the drill bit evenly into the workpiece. Back the bit out frequently to clear deep holes.

CLEARING CHIPS. Turn the machine **OFF** and clear chips and scrap pieces with a brush. Disconnect power, remove drill bit, and clean table before leaving the machine.

OPERATING SPEED. Always operate your drill press at speeds that are appropriate for the drill bit size and the material that you are drilling.

MOUNTING WORKPIECES. Use clamps or vises to secure workpiece before drilling. Position work so you avoid drilling into the table.

TABLE LOCK. Make sure the table lock is tightened before starting the drill press.

MAINTENANCE/SPEED CHANGES. Never change speeds or do maintenance with the machine connected to power.

EXPERIENCING DIFFICULTIES. If at any time you are experiencing difficulties performing the intended operation, stop using the machine! Contact our Technical Support at (570) 546-9663.

WARNING

Like all machines there is danger associated with this machine. Accidents are frequently caused by lack of familiarity or failure to pay attention. Use this machine with respect and caution to lessen the possibility of operator injury. If normal safety precautions are overlooked or ignored, serious personal injury may occur.

CAUTION

No list of safety guidelines can be complete. Every shop environment is different. Always consider safety first, as it applies to your individual working conditions. Use this and other machinery with caution and respect. Failure to do so could result in serious personal injury, damage to equipment, or poor work results.



SECTION 2: POWER SUPPLY

Availability

Before installing the machine, consider the availability and proximity of the required power supply circuit. If an existing circuit does not meet the requirements for this machine, a new circuit must be installed. To minimize the risk of electrocution, fire, or equipment damage, installation work and electrical wiring must be done by an electrician or qualified service personnel in accordance with all applicable codes and standards.

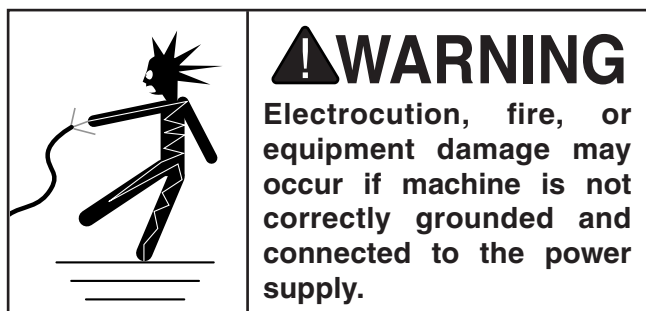

Full-Load Current Rating

The full-load current rating is the amperage a machine draws at 100% of the rated output power. On machines with multiple motors, this is the amperage drawn by the largest motor or sum of all motors and electrical devices that might operate at one time during normal operations.

Full-Load Current Rating at 220V 6.6 Amps

The full-load current is not the maximum amount of amps that the machine will draw. If the machine is overloaded, it will draw additional amps beyond the full-load rating.

If the machine is overloaded for a sufficient length of time, damage, overheating, or fire may result—especially if connected to an undersized circuit. To reduce the risk of these hazards, avoid overloading the machine during operation and make sure it is connected to a power supply circuit that meets the requirements in the following section.

Circuit Requirements for 220V

This machine is prewired to operate on a 220V power supply circuit that has a verified ground and meets the following requirements:

Nominal Voltage 220V/240V
Cycle 60 Hz
Phase 3-Phase
Power Supply Circuit 15 Amps
Plug/Receptacle NEMA 15-15
Cord “S”-Type, 4-Wire, 14 AWG, 300 VAC

A power supply circuit includes all electrical equipment between the breaker box or fuse panel in the building and the machine. The power supply circuit used for this machine must be sized to safely handle the full-load current drawn from the machine for an extended period of time. (If this machine is connected to a circuit protected by fuses, use a time delay fuse marked D.)

! CAUTION

For your own safety and protection of property, consult an electrician if you are unsure about wiring practices or electrical codes in your area.

Note: *The circuit requirements listed in this manual apply to a dedicated circuit—where only one machine will be running at a time. If this machine will be connected to a shared circuit where multiple machines will be running at the same time, consult a qualified electrician to ensure that the circuit is properly sized for safe operation.*



Grounding Instructions

This machine **MUST** be grounded. In the event of certain malfunctions or breakdowns, grounding reduces the risk of electric shock by providing a path of least resistance for electric current.

The power cord and plug specified under "Circuit Requirements for 220V" on the previous page has an equipment-grounding wire and a grounding prong. The plug must only be inserted into a matching receptacle (outlet) that is properly installed and grounded in accordance with all local codes and ordinances (see figure below).

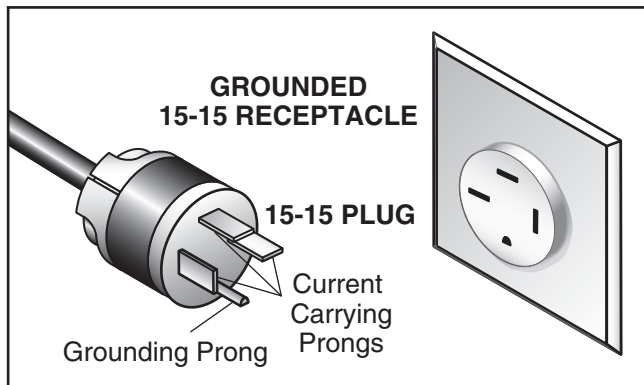
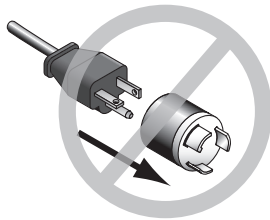

Figure 2. NEMA 15-15 plug and outlet.

CAUTION



No adapter should be used with the required plug. If the plug does not fit the available receptacle, or the machine must be reconnected for use on a different type of circuit, the reconnection must be made by a qualified electrician and comply with all local codes and ordinances.

WARNING

Serious injury could occur if you connect the machine to power before completing the setup process. DO NOT connect to power until instructed later in this manual.

Improper connection of the equipment-grounding wire can result in a risk of electric shock. The wire with green insulation (with or without yellow stripes) is the equipment-grounding wire. If repair or replacement of the power cord or plug is necessary, do not connect the equipment-grounding wire to a live (current carrying) terminal.

Check with a qualified electrician or service personnel if you do not understand these grounding requirements, or if you are in doubt about whether the tool is properly grounded. If you ever notice that a cord or plug is damaged or worn, disconnect it from power, and immediately replace it with a new one.

Extension Cords

We do not recommend using an extension cord with this machine. If you must use an extension cord, only use it if absolutely necessary and only on a temporary basis.

Extension cords cause voltage drop, which may damage electrical components and shorten motor life. Voltage drop increases as the extension cord size gets longer and the gauge size gets smaller (higher gauge numbers indicate smaller sizes).

Any extension cord used with this machine must contain a ground wire, match the required plug and receptacle, and meet the following requirements:

Minimum Gauge Size 14 AWG
Maximum Length (Shorter is Better).....50 ft.



SECTION 3: SETUP

Unpacking

Your machine was carefully packaged for safe transportation. Remove the packaging materials from around your machine and inspect it. If you discover any damage, *please call us immediately at (570) 546-9663 for advice.*

Save the containers and all packing materials for possible inspection by the carrier or its agent. *Otherwise, filing a freight claim can be difficult.*

When you are completely satisfied with the condition of your shipment, inventory the contents.



Needed for Setup

The following are needed to complete the setup process, but are not included with your machine.

Description	Qty
• Additional People	1
• Safety Glasses	1 Per Person
• Cleaner/Degreaser	As Needed
• Disposable Shop Rags.....	As Needed
• Forklift.....	1
• Lifting Straps (Rated 1500 lbs. Minimum) ..	1
• Steel Bar Stock 1" x 3'.....	1

Inventory

The following is a list of items shipped with your machine. Before beginning setup, lay these items out and inventory them.

If any non-proprietary parts are missing (e.g. a nut or a washer), we will gladly replace them; or for the sake of expediency, replacements can be obtained at your local hardware store.

Inventory (see Figure 3):	Qty
A. Drill Chuck B16 3–16mm	1
B. Drill Chuck Arbor MT#4–B16.....	1
C. Spindle Sleeve MT#4–MT#3	1
D. Spindle Sleeve MT#4–MT#2	1
E. Bottle for Oil	1
F. Drift Key.....	1
G. Chuck Key	1
H. Toolbox (not shown)	1

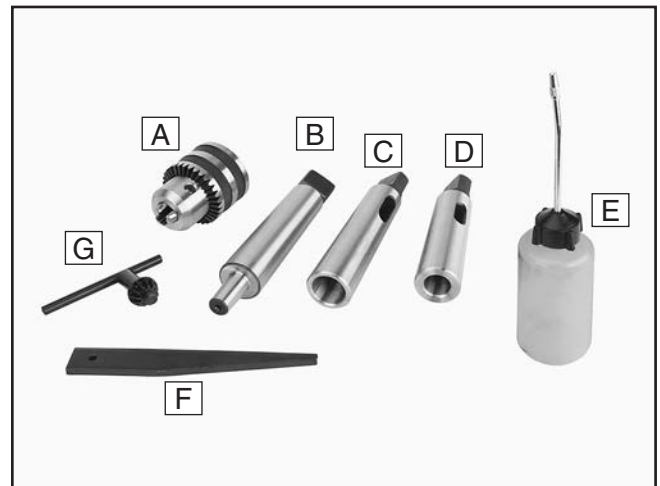

Figure 3. Toolbox inventory.

NOTICE

If you cannot find an item on this list, carefully check around/inside the machine and packaging materials. Often, these items get lost in packaging materials while unpacking or they are pre-installed at the factory.



Cleanup

The unpainted surfaces of your machine are coated with a heavy-duty rust preventative that prevents corrosion during shipment and storage. This rust preventative works extremely well, but it will take a little time to clean.

Be patient and do a thorough job cleaning your machine. The time you spend doing this now will give you a better appreciation for the proper care of your machine's unpainted surfaces.

There are many ways to remove this rust preventative, but the following steps work well in a wide variety of situations. Always follow the manufacturer's instructions with any cleaning product you use and make sure you work in a well-ventilated area to minimize exposure to toxic fumes.

Before cleaning, gather the following:

- Disposable rags
- Cleaner/degreaser (WD•40 works well)
- Safety glasses & disposable gloves
- Plastic paint scraper (optional)

Basic steps for removing rust preventative:

1. Put on safety glasses.
2. Coat the rust preventative with a liberal amount of cleaner/degreaser, then let it soak for 5–10 minutes.
3. Wipe off the surfaces. If your cleaner/degreaser is effective, the rust preventative will wipe off easily. If you have a plastic paint scraper, scrape off as much as you can first, then wipe off the rest with the rag.
4. Repeat **Steps 2–3** as necessary until clean, then coat all unpainted surfaces with a quality metal protectant to prevent rust.

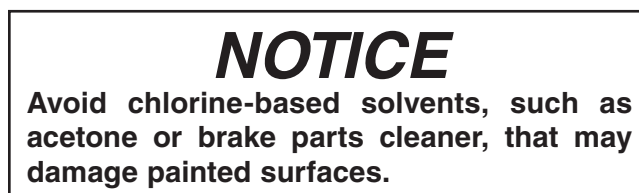
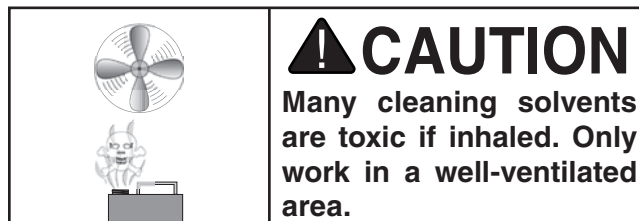
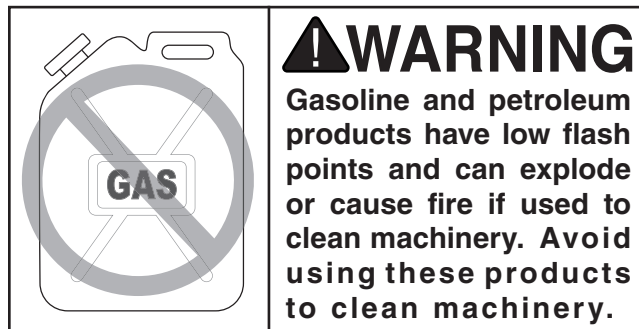

T23692—Orange Power Degreaser

A great product for removing the waxy shipping grease from your machine during clean up.



Figure 4. T23692 Orange Power Degreaser.



Site Considerations

Weight Load

Refer to the **Machine Data Sheet** for the weight of your machine. Make sure that the surface upon which the machine is placed will bear the weight of the machine, additional equipment that may be installed on the machine, and the heaviest workpiece that will be used. Additionally, consider the weight of the operator and any dynamic loading that may occur when operating the machine.

Space Allocation

Consider the largest size of workpiece that will be processed through this machine and provide enough space around the machine for adequate operator material handling or the installation of auxiliary equipment. With permanent installations, leave enough space around the machine to open or remove doors/covers as required by the maintenance and service described in this manual. **See below for required space allocation.**

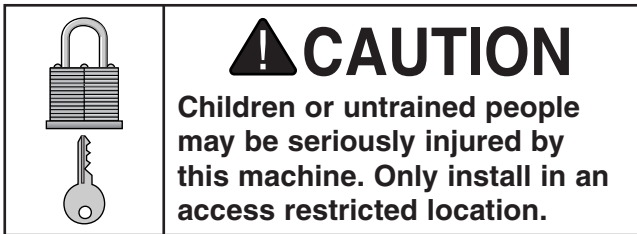

Physical Environment

The physical environment where the machine is operated is important for safe operation and longevity of machine components. For best results, operate this machine in a dry environment that is free from excessive moisture, hazardous chemicals, airborne abrasives, or extreme conditions. Extreme conditions for this type of machinery are generally those where the ambient temperature range exceeds 41°–104°F; the relative humidity range exceeds 20–95% (non-condensing); or the environment is subject to vibration, shocks, or bumps.

Electrical Installation

Place this machine near an existing power source. Make sure all power cords are protected from traffic, material handling, moisture, chemicals, or other hazards. Make sure to leave access to a means of disconnecting the power source or engaging a lockout/tagout device, if required.

Lighting

Lighting around the machine must be adequate enough that operations can be performed safely. Shadows, glare, or strobe effects that may distract or impede the operator must be eliminated.

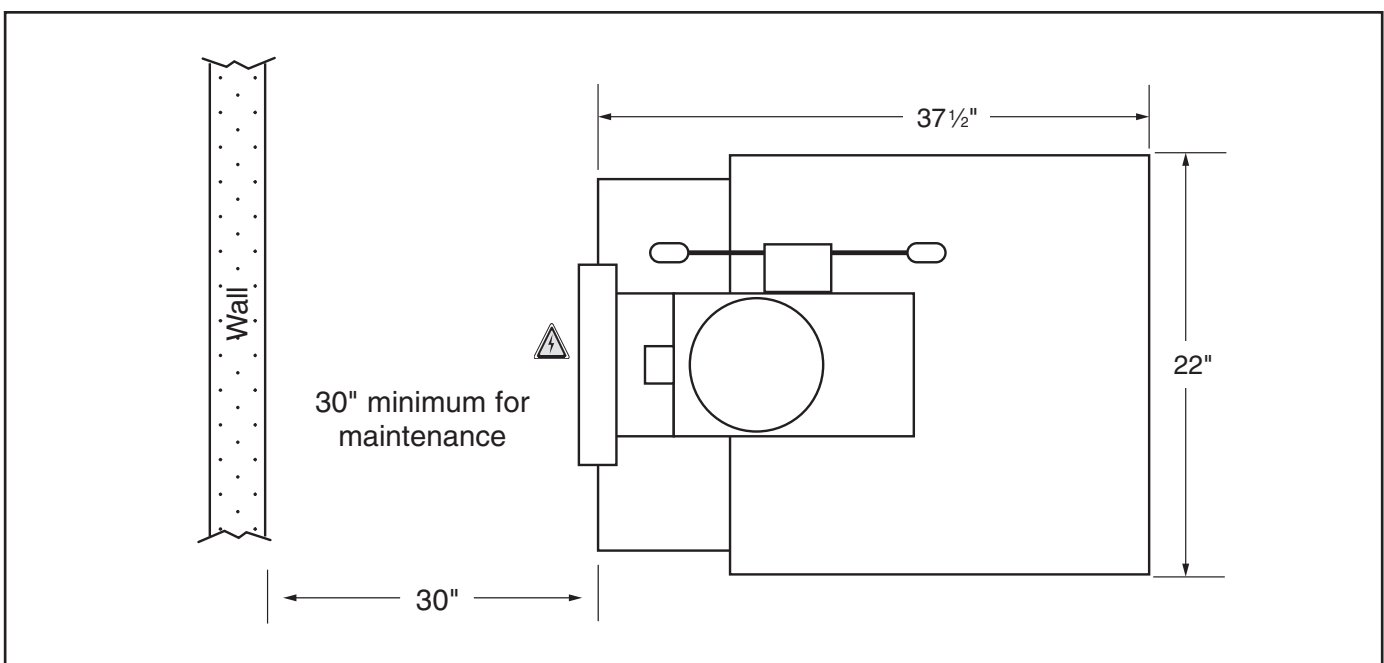
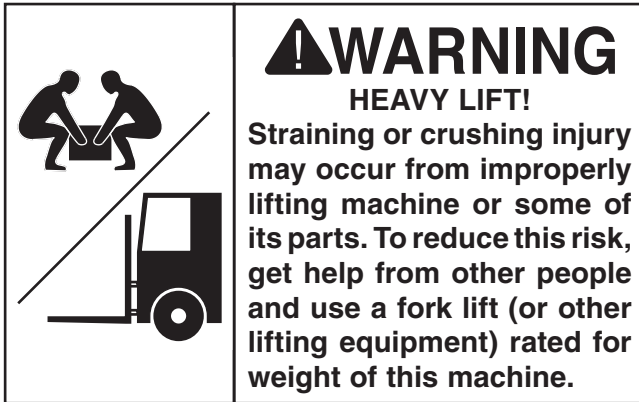

Figure 5. Minimum working clearances.



Lifting & Placing



To move and place this drill:

1. Place shipping crate near final machine mounting location.
2. Remove top portion of crate from the shipping pallet, secure the ends of a properly rated lifting strap around each side of the bar placed through the lifting holes, and attach it securely to your power lifting equipment (see **Figure 6**).

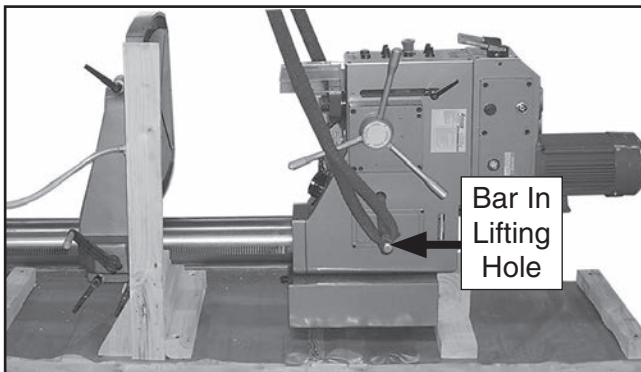

Figure 6. Strap around bar in lifting hole.

3. Unbolt the machine from the pallet.
4. With another person to help to steady the machine, lift it just enough to clear the pallet and any floor obstacles, then place it in its final position.

Anchoring to Floor

Anchoring machinery to the floor prevents tipping or shifting and reduces vibration that may occur during operation, resulting in a machine that runs slightly quieter and feels more solid.

If the machine will be installed in a commercial or workplace setting, or if it is permanently connected (hardwired) to the power supply, local codes may require that it be anchored to the floor.

If not required by any local codes, fastening the machine to the floor is an optional step. If you choose not to do this with your machine, we recommend placing it on machine mounts, as these provide an easy method for leveling and they have vibration-absorbing pads.

Anchoring to Concrete Floors

Lag shield anchors with lag screws (see below) are a popular way to anchor machinery to a concrete floor, because the anchors sit flush with the floor surface, making it easy to unbolt and move the machine later, if needed. However, anytime local codes apply, you **MUST** follow the anchoring methodology specified by the code.

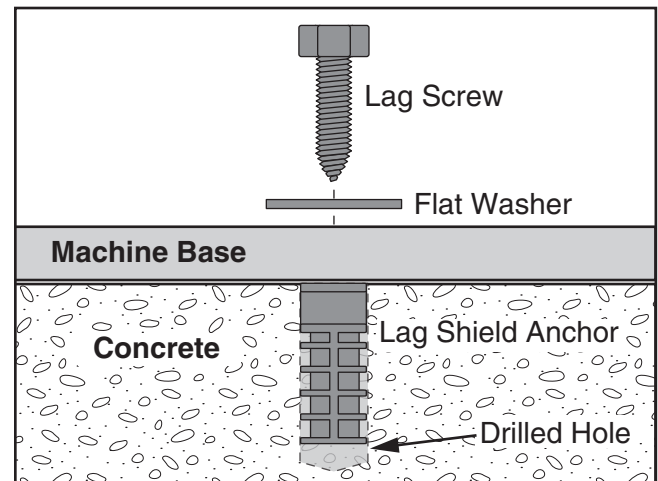

Figure 7. Popular method for anchoring machinery to a concrete floor.



Arbor/Chuck Assembly

An arbor is included for the drill chuck that comes with this machine. The following procedure describes how to install the arbor in the chuck.

After the arbor is installed in the drill chuck, it is very difficult to separate the assembly. If you would like to use a different chuck in the future, we suggest using a different arbor.

Important: *DO NOT install the drill chuck and arbor assembly until AFTER the test run.*

To connect the drill chuck with the arbor:

1. Use acetone or lacquer thinner to clean drill chuck and arbor mating surfaces, especially the bore.
2. Retract the chuck jaws so that they are not exposed.
3. Insert the arbor into the drill chuck.
4. Hold assembly by the arbor and tap chuck onto a block of wood with moderate force (see **Figure 8**).

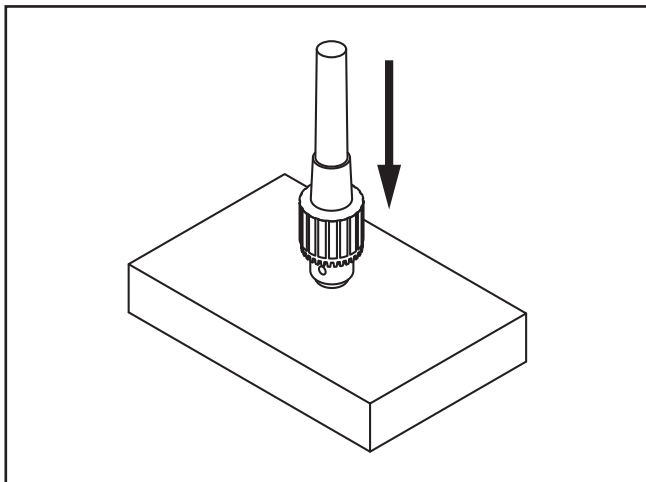

Figure 8. Installing arbor into chuck.

Initial Lubrication



To prevent spillage, this machine was shipped from the factory without any oil in it. The head-stock oil reservoir must be properly filled with oil before the drill press can be operated for the first time. Refer to the **Lubrication** section, beginning on **Page 33**, for details on how to check and add oil.

NOTICE

Damage caused by running the drill press without oil in the reservoir will not be covered under warranty.



Power Connection

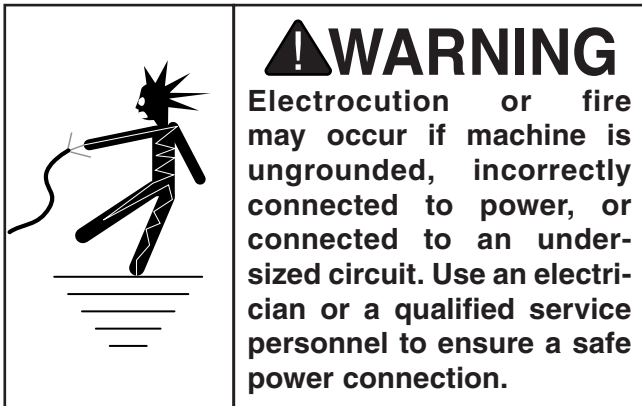

Before the machine can be connected to the power source, an electrical circuit must be made available that meets the minimum specifications given in **Circuit Requirements for 220V** on **Page 10**. If a power circuit has not been prepared for the machine, do that now.

To minimize the risk of electrocution, fire, or equipment damage, all installation work and electrical wiring **MUST** be done by an electrician or qualified service personnel.

Note about extension cords: *Using an incorrectly sized extension cord may decrease the life of electrical components on your machine. Refer to **Extension Cords** on **Page 11** for more information.*

To connect the power cord to the machine:

1. Turn the master power switch to OFF, then open the electrical cabinet door located at the back of the machine.

2. Identify the L1, L2, and L3 terminals and the grounding terminal (see **Figure 9**).
3. Thread the power cord through the strain relief shown in **Figure 9**.

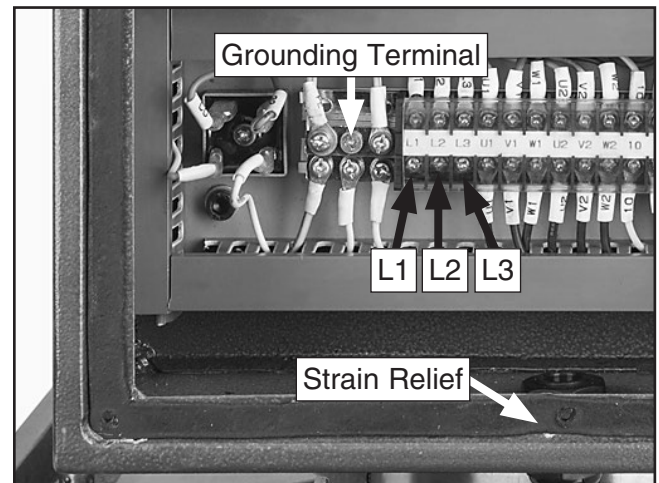

Figure 9. Location of hot wire terminals, ground terminal, and strain relief.

4. Connect the incoming hot wires and ground wire to the terminals shown in **Figure 10**.

Note: *If using a phase convertor, the "wild wire" is connected to the L2 terminal.*

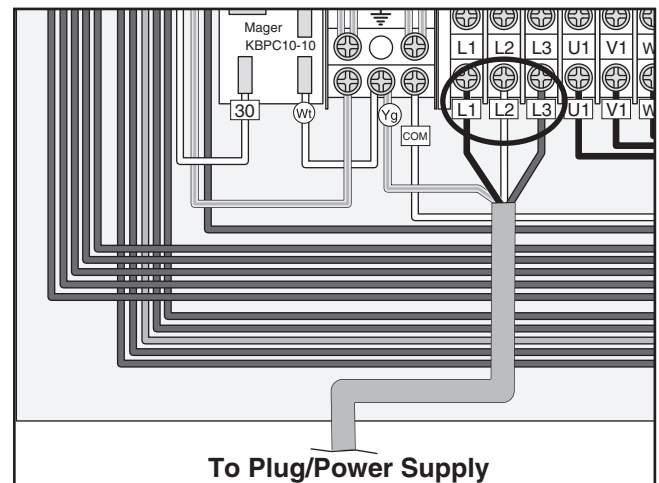

Figure 10. Ground and hot wires connected.



5. Make sure the power cord and wires have slack between the strain relief and terminal connections so that they do not bind, then tighten the strain relief to secure the cord.

Note: *The strain relief must be tightened against the outer jacket of the cord. Avoid over-tightening the strain relief or it may crush the cord and cause a short.*

6. Test the strain relief to ensure it is properly tightened by pulling the cord from outside the box with light-to-moderate force. When the strain relief is properly tightened, the cord will not move inside the cabinet.
7. Install a NEMA 15-15 plug on the other end of the power cord per the plug manufacturer's instructions.
8. Close and secure the main electrical box door.
9. Plug the power cord into a power source with a matching receptacle, as specified in **Circuit Requirements for 220V** on **Page 10**.

Note: *If you discover during the Test Run that the drill press will not operate, or that the spindle runs backwards, the drill press may be wired out of phase.*

Correcting the phase polarity requires reversing the positions where the L1 and L3 wires are connected. Due to the high voltage and risk of serious shock involved, we strongly recommend this procedure only be done by an electrician or qualified service personnel.

Test Run

Once the preceding setup procedures are complete, test run your machine to make sure it runs properly and is ready for regular operation.

The test run consists of verifying the following: 1) The motor powers up and runs correctly, 2) the EMERGENCY STOP button and chip guard safety features work correctly, and 3) the motor rotates in the correct direction (machine is not wired out of phase).

If, during the test run, you cannot easily locate the source of an unusual noise or vibration, stop using the machine immediately, then review **Troubleshooting** on **Page 35**.

If you still cannot remedy a problem, contact our Tech Support at (570) 546-9663 for assistance.

!WARNING

Before starting the drill press, make sure you have performed the preceding setup instructions, and you have read through the rest of the manual and are familiar with the various functions and safety features on this machine. Failure to follow this warning could result in serious personal injury or even death!

To test run the machine:

1. Make sure all tools and objects used during setup are cleared away from the machine.
2. Make sure the machine is properly lubricated.
3. Turn the Master Power Switch (**Figure 11**) **ON**.



Figure 11. Master power switch.



4. Press the EMERGENCY STOP button (Figure 12) in, then twist it clockwise so it pops out. When the button pops out the switch is reset and ready for operation.

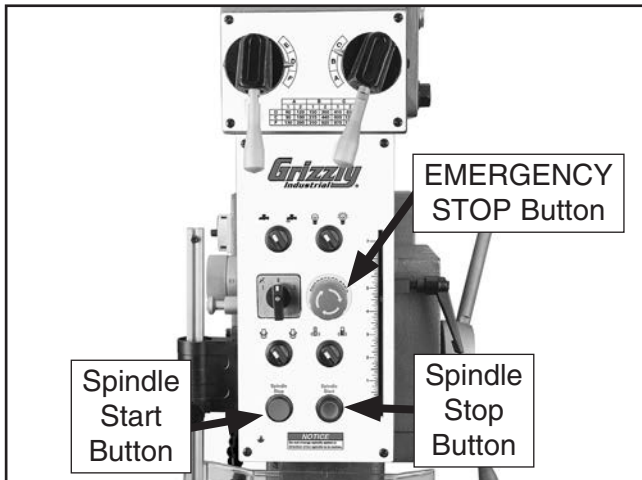

Figure 12. Resetting the switch.

5. Verify that the machine is operating correctly by turning the spindle rotation switch to the left position and pressing the spindle start button.

—When operating correctly, the machine runs smoothly with little or no vibration or rubbing noises.

—Investigate and correct strange or unusual noises or vibrations before operating the machine further. Always stop the machine and disconnect it from power before investigating or correcting potential problems.

—Verify that oil is flowing through the headstock by examining the oil flow sight glass for oil movement (see Page 33).

—If the spindle direction switch is turned to the left and the bit turns from right to left (as standing in front of the machine), it is turning in the correct direction.

—If the bit turns from left to right (as standing in front of the machine), see Page 17 for instructions on correcting phase polarity.

6. Press the EMERGENCY STOP button and ensure that the drill press comes to a complete stop.

7. WITHOUT resetting the EMERGENCY STOP button, press the spindle start button. The machine should not start.

—If the machine *does not* start, the EMERGENCY STOP button safety feature is working correctly.

—If the machine *does* start (with the EMERGENCY STOP button pressed in), immediately disconnect power to the machine. The EMERGENCY STOP button safety feature is not working correctly. This safety feature must work properly before proceeding with regular operations. Call Tech Support for help.

8. Press the EMERGENCY STOP button in, then twist it clockwise so it pops out. When the button pops out, the switch is reset and ready for operation.

9. Rotate the chip guard out of position and press the spindle start button. The machine should not start.

—If the machine does not start, the chip guard safety feature is working correctly.

—If the machine starts, immediately disconnect power to the machine. This safety feature must work properly before proceeding with regular operations. Call Tech Support for help.

Congratulations! The test run is now complete. Before beginning any regular operations, perform the Spindle Break-In procedure on Page 21.



Test Coolant System

This drill press comes with a pump-driven cycling coolant system. Prior to testing the coolant system, add two gallons of coolant to the coolant reservoir. Refer to **Changing Coolant** on **Page 28**.

To test the coolant system:

1. Wear safety goggles and other protective clothing.
2. Aim the coolant nozzle into the trough to reduce splash (see **Figure 13**).

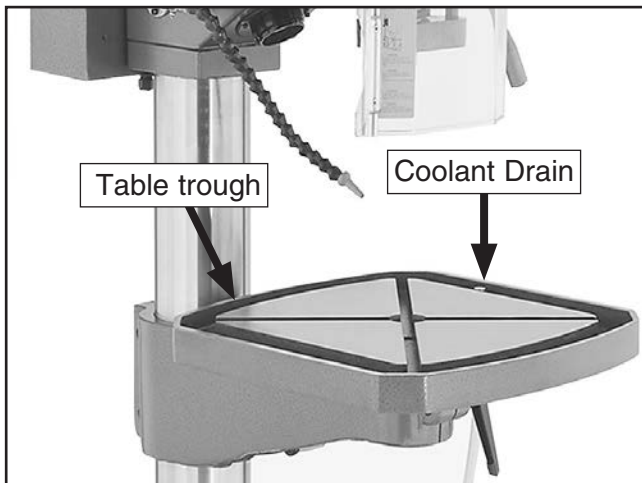

Figure 13. Table trough and coolant drain.

3. Turn the Coolant Pump Switch to the ON position.
4. Adjust the ball valve in the coolant nozzle assembly for the proper coolant flow (see **Figure 14**).



Figure 14. Ball valve of nozzle assembly.

5. Close the ball valve and turn the pump switch to the OFF position.

NOTICE

Running the pump without adequate coolant can significantly damage the pump, which will not be covered under warranty.



Spindle Break-In

Before subjecting the spindle to operational loads, it is essential to complete the break-in process. This helps ensure maximum life of spindle bearings and other precision components by thoroughly lubricating them before placing them under load.

After spindle break-in is complete, we recommend changing headstock and gearbox oil to remove any metal particles or debris that are present from the assembly and break-in process.

The break-in must be performed in succession with the **Test Run** procedure described in this manual, as the steps in that procedure prepare the drill press for the break-in process.

NOTICE

DO NOT perform this procedure independently of the Test Run section. The drill press could be seriously damaged if the controls are set differently than instructed in that section.

To perform the spindle break-in procedure:

1. Move the drilling & tapping switch to the drilling position (see **Figure 15**).

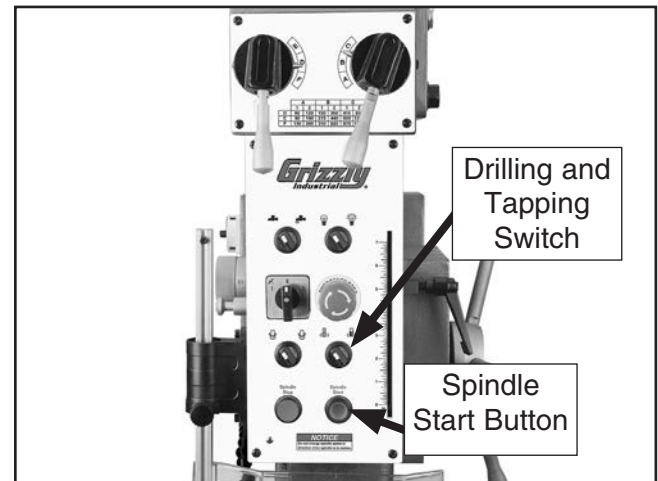

Figure 15. Drilling/tapping switch.

2. Position the speed control levers for 440 RPM.
3. Press the spindle start button.
4. Allow the machine to run for 10 minutes.
5. Press the spindle stop button.
6. Position the speed control levers for 870 RPM, and allow machine to run for 10 minutes.
7. Press the OFF button, and adjust the speed control levers for 440 RPM.
8. Press the spindle start button.
9. Press the button on the end of the downfeed handle to reverse spindle rotation.
10. Run the machine at 440 RPM and then 870 RPM for 10 minutes each, as described above.
11. Run the machine at 440 RPM for another 15 minutes to allow it cool down.

Congratulations! Spindle break-in is complete. We recommend changing the headstock and gearbox oil before operating the machine further (refer to lubrication on **Page 33**).



SECTION 4: OPERATIONS

Operations Overview

The purpose of this overview is to provide the novice machine operator with a basic understanding of how the machine is used during operation, so the machine controls/components discussed later in this manual are easier to understand.

Due to the generic nature of this overview, it is **not** intended to be an instructional guide. To learn more about specific operations, read this entire manual and seek additional training from experienced machine operators, and do additional research outside of this manual by reading "how-to" books, trade magazines, or websites.

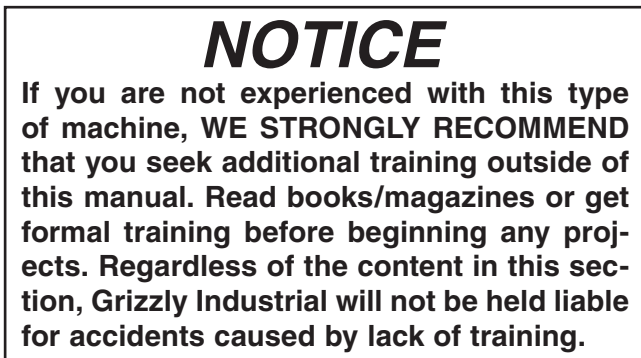
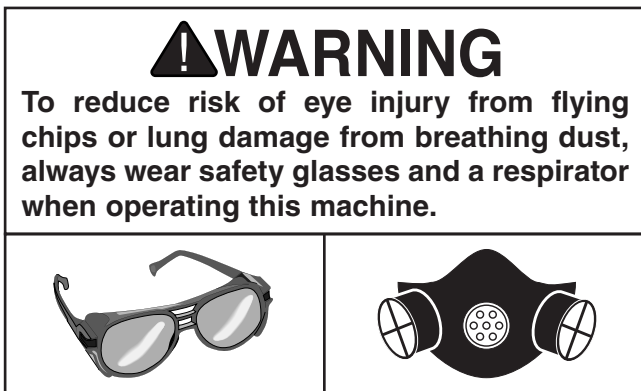

To complete a typical operation, the operator does the following:

1. Examines the workpiece to make sure it is suitable for drilling.
2. Puts on the required safety gear.
3. Firmly secures the workpiece to the table using a vise or T-slot clamps.
4. Installs the correct cutting tool for the operation.
5. Adjusts table to the correct height, then locks it in place.
6. Connects the machine to power, and turns the master power switch **ON**.
7. Selects the spindle RPM with the speed control levers and presses the spindle start button.
8. Begins drilling.
9. When finished, presses the spindle stop button and disconnects it from power.

Tooling Installation & Removal

This machine has an MT#4 spindle for installing tooling. It is also equipped with an automatic drift for easy removal of tooling (see **Figure 16**). Additionally, a drift key is included to manually remove the tooling from the spindle, if needed.



Installing Tapered Tooling

1. DISCONNECT MACHINE FROM POWER!
2. Clean tooling and spindle tapers to ensure proper seating.
3. Insert the MT#4 tooling into the spindle, and maneuver the tang until it engages with the slot at the end of the spindle.
4. Use a rubber or wooden mallet to seat the tooling into the spindle by firmly tapping from the bottom.

Note: If installing a drill chuck, make sure to retract the jaws to prevent damage to chuck.

Removing Tooling with Automatic Drift

1. DISCONNECT MACHINE FROM POWER!
2. Lower the spindle with the coarse downfeed handle until you can press in the automatic drift knob (see **Figure 16**).



Figure 16. Automatic drift knob.

⚠ WARNING

Leaving the automatic drift knob pressed in can result in the arbor coming free the next time it is inserted into the spindle sleeve. An improperly installed arbor can become a projectile and result in serious injury to operator or others nearby. Always verify arbor is correctly installed before beginning drilling operations.

3. While holding onto the tooling, raise the spindle to the original position. It should automatically release from the spindle.
4. Pull the automatic drift knob back to the outward position.

Removing Tooling Manually

1. DISCONNECT MACHINE FROM POWER!
2. Lower the quill and rotate the spindle by hand until the drift key holes in the spindle and quill are aligned (see **Figure 17**).



Figure 17. Spindle and quill drift key holes aligned.

3. Insert the drift key into the aligned holes and allow the quill to rise, trapping the drift key.
4. Softly tap the end of the key while holding the arbor/chuck assembly until it separates from the spindle (see **Figure 18**).



Figure 18. Using drift key to remove arbor.

Depth Stop

This drill press includes a depth stop for drilling multiple holes at the same depth.

To set the depth stop:

1. DISCONNECT MACHINE FROM POWER!
2. Adjust the table height so the workpiece is close to the work tool.
3. Mark the side of your workpiece at the intended cutting depth (see **Figure 19**).

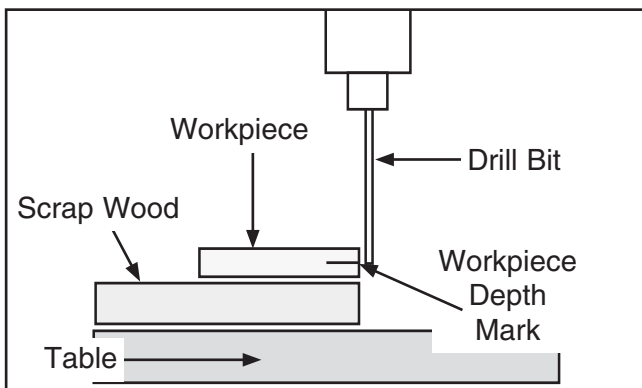

Figure 19. Depth stop mark on workpiece.

4. Secure the workpiece to the table with a clamp or vise.
5. Place the workpiece on the table, and lower the spindle until the tip of the bit is even with the mark.
6. Loosen the depth stop handle, move the drill bit to the required drilling depth, and tighten it (see **Figure 20**).

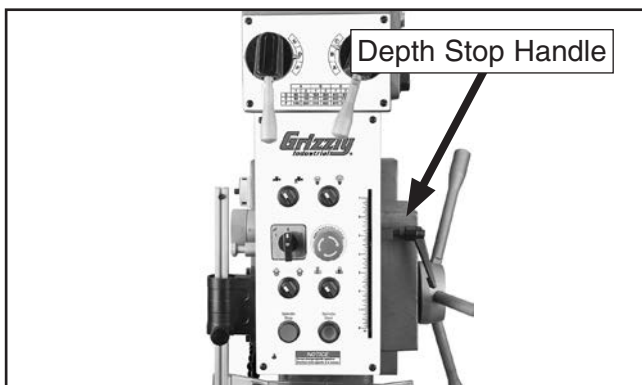

Figure 20. Setting depth stop handle.

7. Press the spindle start button.
8. Drill a hole into scrap stock before drilling into any workpiece to ensure the depth has been set correctly. If necessary, repeat **Steps 2–5**.

Table Positioning

The table for this drill press moves vertically and rotates 360 degrees to accommodate larger workpieces.

Raising/Lowering Table

1. Remove any objects from the table surface.
2. Loosen the release handles shown in **Figure 21**.
3. Adjust the table height by rotating the height adjustment handle (see **Figure 21**).

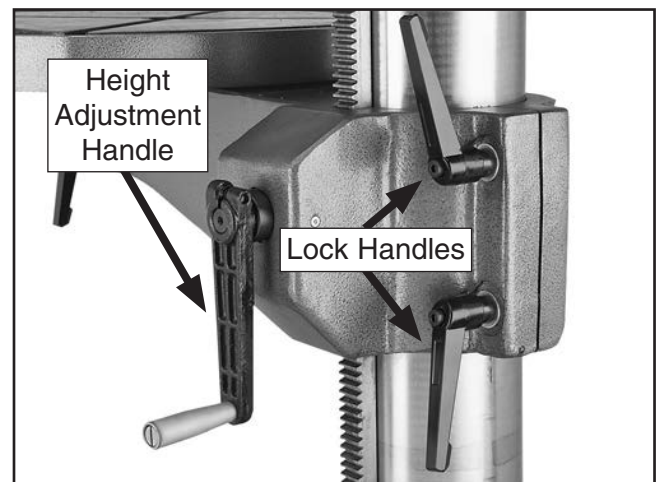

Figure 21. Column Release and Height Adjustment Handles.

Rotating Table

1. Remove all objects from the table surface.
2. Slightly loosen the lock handles (see **Figure 21**).
3. Push the table to the desired location, and guide the rack on the side of the column.
4. Re-tighten the lock handles.



Selecting Spindle RPM

Note: For carbide cutting tools, double the cutting speed. These values are a guideline only. Refer to the MACHINERY'S HANDBOOK for more detailed information.

Use the proper spindle speed and feed rate to reduce strain on all moving parts and decrease risk of operator injury.

Prior to drilling, determine the RPM needed for workpiece material then set the spindle speed to the closest available RPM.

To determine the needed RPM:

1. Use the table in **Figure 22** to determine the speed required for your workpiece material.

⚠ CAUTION

Larger bits turning at slower speeds tend to grab the workpiece aggressively. This can result in the operator's hand being pulled into the bit or the workpiece being thrown with great force. Always clamp the workpiece to the table to prevent injuries.

Twist/Brad Point Drill Bits	Soft Wood	Hard Wood	Plastic	Brass	Aluminum	Mild Steel
1/16" – 3/16"	3000	2500	2500	2500	3000	2500
13/64" – 3/8"	2000	1500	2000	1250	2500	1250
25/64" – 5/8"	1500	750	1500	750	1500	600
11/16" – 1"	750	500	1000	400	1000	350
Spade/Forstner Bits	Soft Wood	Hard Wood	Plastic	Brass	Aluminum	Mild Steel
1/4" – 1/2"	2000	1500				
9/16" – 1"	1500	1250				
1-1/8" – 1-7/8"	1000	750				
2–3"	500	350				
Hole Saws	Soft Wood	Hard Wood	Plastic	Brass	Aluminum	Mild Steel
1/2" – 7/8"	500	500	600	600	600	500
1" – 1-7/8"	400	400	500	500	500	400
2" – 2-7/8"	300	300	400	400	400	300
3" – 3-7/8"	200	200	300	300	300	200
4" – 5"	100	100	200	200	200	100
Rosette Cutters	Soft Wood	Hard Wood	Plastic	Brass	Aluminum	Mild Steel
Carbide Insert Type	350	250				
One-Piece Type	1800	500				
Tenon/Plug Cutters	Soft Wood	Hard Wood	Plastic	Brass	Aluminum	Mild Steel
3/8" – 1/2"	1200	1000				
5/8" – 1"	800	600				

Figure 22. Cutting speed table for HSS cutting tools.



Drilling Mode

This drill press is designed for vertical drilling and tapping operations. For repeated drilling at the same depth, there is a power downfeed mechanism. For tapping convenience, there is an automatic clutch used for reversing the direction of the spindle while in tapping mode by pressing one of the buttons at the ends of each course downfeed handle.

WARNING

Overloading tools or using excessive spindle speeds may cause parts or broken tools to hit operator, resulting in serious impact injuries.

To drill a workpiece:

1. Refer to **Controls** on **Page 4** to understand the functions of each control.

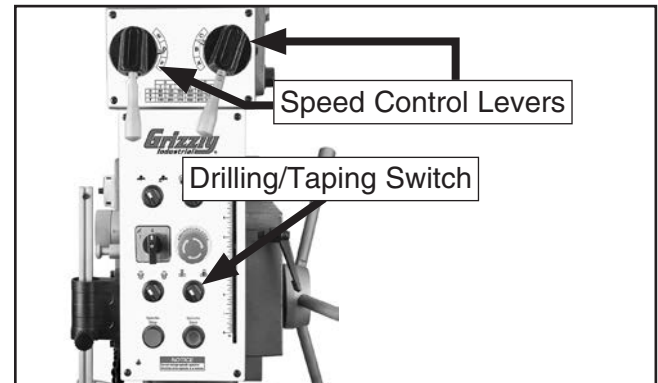

Figure 23. Controls for drilling.

2. Clamp the workpiece to the table, and adjust the depth stop for the needed depth of cut.

***Note:** Drilling with the quill fully extended can cause tool chatter. For maximum spindle rigidity, keep the spindle retracted into the headstock as far as possible.*

3. Put on safety glasses, a face shield, and close the chip guard.
4. Select the "drilling" mode option with the toggle switch.
5. Refer to **Selecting Spindle RPM** on **Page 25**, and choose the closest available spindle RPM.
6. Turn the Master Power Switch **ON**.
7. Press the spindle start button and begin the drilling operation.



Automatic Power Downfeed

This drill press comes with automatic downfeed control for repeated drilling operations at the same depth. The automatic downfeed only works in the drilling mode.

!WARNING

Stay clear of coarse downfeed handles while using the automatic downfeed. When the depth stop triggers the lower elevation limit switch, the handles spin rapidly as the spindle returns to its starting position. Failure to stay clear of the handles may result in injury.

To operate the automatic power downfeed:

1. DISCONNECT MACHINE FROM POWER!
2. Select the drilling option with the drilling/tapping switch.
3. Set the spindle depth stop to the desired position (refer to **Page 24**).

4. Match the lines on the adjustment knob to select an automatic power downfeed option (see **Figure 24**).

—There are three options for the power downfeed mechanism that are located on the side of the adjustment knob:

- 0.2 is equal to 2mm of downfeed per spindle rotation.
- 0.1 is 1mm of downfeed per spindle rotation.
- 0.0 disengages the downfeed mechanism.

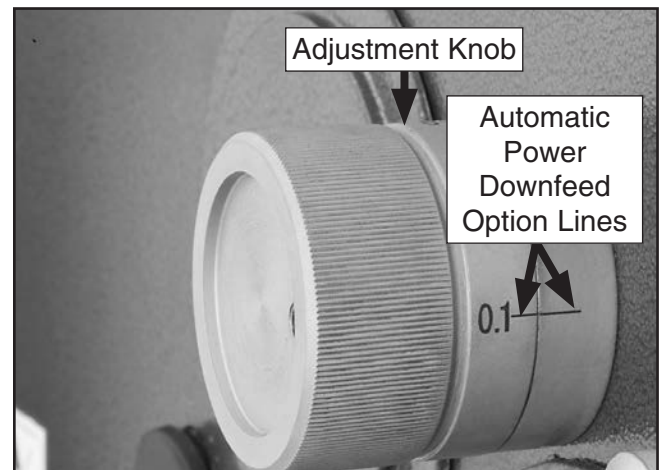

Figure 24. Automatic downfeed adjustment knob.

5. Re-connect machine to power.
6. Turn the Master Power Switch **ON**, and press the spindle start button.
7. Pull the coarse downfeed handle down towards the front of the machine until the automatic downfeed begins.



Tapping Mode

When in tapping mode, the spindle direction can immediately alternate between forward and reverse by pressing any of the three buttons at the end of the downfeed handles. This feature is critical to back the tap out of a hole before it bottoms out and snaps off, as well as clearing away waste chips during the tapping process.

Pilot holes must be drilled prior to beginning any tapping operation.

To use tapping mode:

1. DISCONNECT MACHINE FROM POWER!
2. Determine the maximum tapping depth without bottoming-out the tap, and adjust the depth stop accordingly.
3. Clamp the workpiece to the table.
4. Put on safety glasses and a face shield. Select tapping mode, and turn the spindle rotation switch counter-clockwise.
5. Install the tap, and apply tapping fluid to the contact point of the tap and workpiece.
6. Connect the machine to power.
7. Select "tapping" mode with the drilling/tapping switch
8. Select the appropriate spindle speed. Speeds vary according to the material, bit, and procedure. There are several online resources to choose from for calculating spindle speed
9. Press the spindle start button.
10. Begin threading. Without disengaging the tap from the threads, frequently alternate spindle rotation by pressing any end button to reverse spindle and eject chips from the hole. Frequently removing chips will prevent galling and tap breakage.

Coolant System

This machine comes with a coolant system for use in drilling and tapping operations. This feature promotes precision cutting and tool longevity.

To operate the coolant system:

1. Ensure there is a sufficient amount of clean coolant in the reservoir (refer to **Page 20** for detailed instructions).
2. Aim the coolant nozzle at the contact area of the workpiece and the work tool.
3. Turn the coolant pump switch on the control panel to the ON position.
4. Regulate the coolant flow to the contact area using the coolant ball valve shown in **Figure 25**.

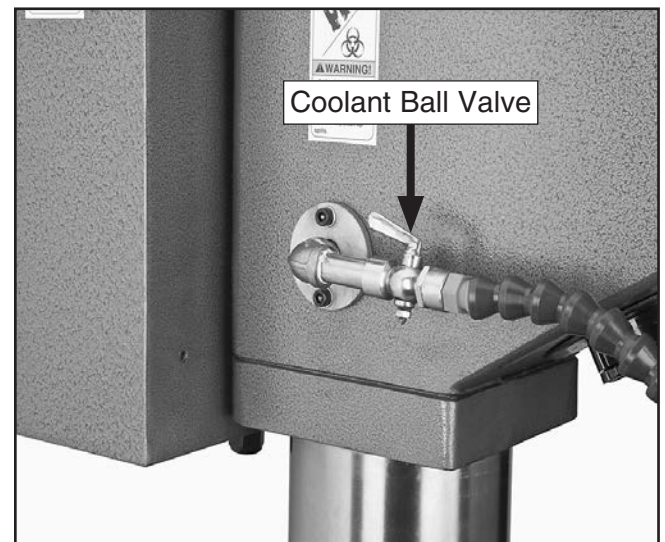

Figure 25. Coolant ball valve.



SECTION 5: ACCESSORIES

! WARNING

Installing unapproved accessories may cause machine to malfunction, resulting in serious personal injury or machine damage. To reduce this risk, only install accessories recommended for this machine by Grizzly.

NOTICE

Refer to our website or latest catalog for additional recommended accessories.

G5753—Drill Press Vice - 6"

If you use a drill press and value your fingers, you need one of these. Made from high-grade cast iron, these hefty horizontal vises offer support and stability, allowing you to keep your hands well away from fast moving bits and cutters. Includes a sturdy lip along both sides of the base, allowing vise to be mounted to nearly any machine table, using common T-slot clamps.



Figure 26. Cast iron drill press vice.

G1075—52-PC. Clamping Kit

This clamping kit includes 24 studs, 6 step block pairs, 6 T-nuts, 6 flange nuts, 4 coupling nuts, and 6 end hold-downs. The rack is slotted so it can be mounted close to the machine for easy access. Made for 1/2" T-slots.

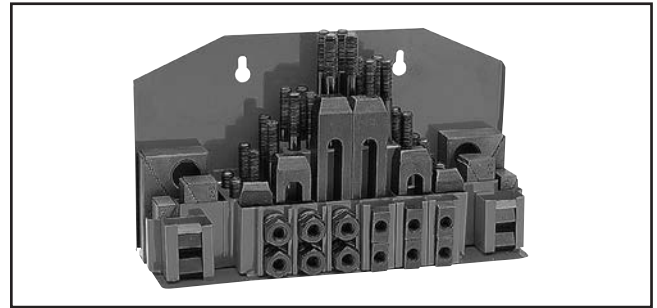

Figure 27. Clamping Kit.

T20501—Face Shield Crown Protector 4"

T20502—Face Shield Crown Protector 7"

T20503—Face Shield Window

T20452—"Kirova" Anti-Reflective S. Glasses

T20451—"Kirova" Clear Safety Glasses

H0736—Shop Fox® Safety Glasses

H7194—Bifocal Safety Glasses 1.5

H7195—Bifocal Safety Glasses 2.0

H7196—Bifocal Safety Glasses 2.5



Figure 28. Safety glasses.

order online at www.grizzly.com or call 1-800-523-4777



T23962—ISO 68 Moly-D Way Oil, 5 gal.

T23963—ISO 32 Moly-D Machine Oil, 5 gal.

Moly-D oils are some of the best we've found for maintaining the critical components of machinery because they tend to resist run-off and maintain their lubricity under a variety of conditions—as well as reduce chatter or slip. Buy in bulk and save with 5-gallon quantities.



Figure 29. ISO 68 and ISO 32 machine oil.

H7527—6" ROTARY TABLE SET

Use this 6" Rotary Table in either the horizontal or vertical position for a variety of milling applications and with the set of dividing plates and adjustable tailstock, your milling applications are nearly unlimited. With 4° table movement per handle rotation and 20 second vernier scale, control is very accurate and precise. Also includes a 3/8" clamping set for the 4-slot table. Everything you need in one great set!

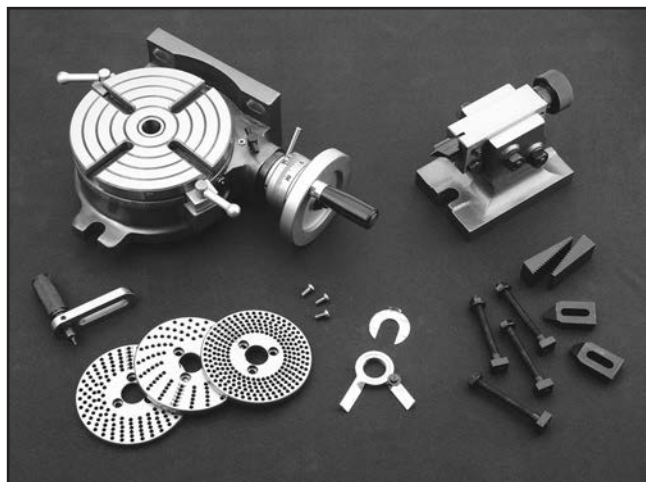

Figure 30. Rotary table with dividing plates.

G3658—Titanium Drill Bits

Titanium nitride-coated bits last up to six times as long as uncoated bits. This 115-piece set features 29 fractional bits, from 1/6" to 1/2" in increments of 1/64", letter bits from A–Z, and 60 number bits. Housed in rugged steel case.

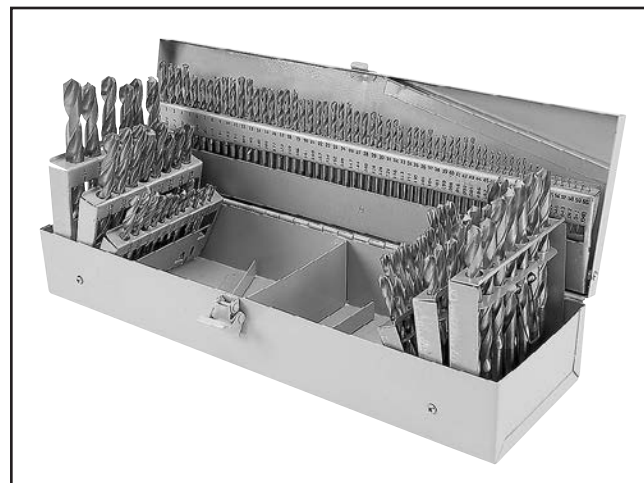

Figure 31. 115 piece drill bit set.

H7616—Oil Can w/Plastic Nozzle

H7617—Oil Can w/Flexible Plastic Nozzle

These high-pressure oil cans are perfect for lubricating the ball oilers found on your machine. Each can holds 5 ounces of oil.



Figure 32. High pressure oil cans.



H7819—Drill & Tap HSS 24 pc. Set

Our new High Speed Steel Tap and Drill Set comes supplied with 6 of the most commonly used coarse thread sizes. What's more, each size has taps with plug, bottoming and taper grinds allowing you to choose the right tap for any job. The set includes the following tap sizes and corresponding drill bits: 8-32 & #29, 10-24 & #25, 1/4"-20 & #7, 5/16"-18 & F, 3/8"-16 & 5/16" and 1/2"-13 & 27/64".



Figure 33. Commonly used tap and drill set.

H8262—1/2" x MT#4 Keyless Chuck with Integral Shank

Precision, Keyless Drill Chucks have integral shanks to fit a variety of spindles including Morse taper, R8 and Cat 40. Each chuck has a knurled grip for plenty of torque and if that's not enough, they're spanner wrench compatible. (Spanner wrench not included.) Made in an ISO 9001 certified factory.



Figure 34. Precision keyless drill chuck.



SECTION 6: MAINTENANCE

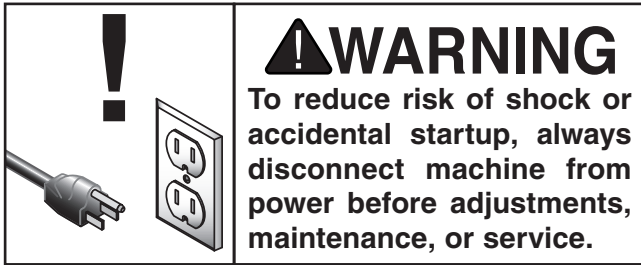

Schedule

Typically, each operator is responsible for ensuring proper care of the equipment. We strongly recommend all operators make a habit of following the daily maintenance procedures.

Ongoing

To reduce the risk of injury and ensure proper machine operation, if you ever observe any of the items below, shut down the machine immediately and fix the problem before continuing operations:

- Loose mounting bolts or fasteners.
- Worn, frayed, cracked, or damaged wires.
- Chip guard removed.
- EMERGENCY STOP button not working correctly or not requiring you to reset it before starting the machine again.
- Any other unsafe condition.

Every 8 hour of operation:

- Lubricate the ball oilers (**Page 34**).
- Check/Add headstock oil (**Page 33**).
- Check quantity/quality of coolant (**Page 20**).

Annually:

- Change headstock oil (**Page 33**).

Daily, After Operations

- Thoroughly clean the machine and protect all surface areas
- Press the EMERGENCY STOP button and shut **OFF** the master power switch (to prevent accidental startup).
- Remove any rotary tables, vises, fixtures, or workpieces from the table to prevent rusting the table surface.

Annually

- Disconnect machine from power, open electrical box, and clean with compressed air.

Cleaning and Protecting

Metal chips left on the machine will invite oxidation and a gummy residue build-up around the moving parts. Use a brush and shop vacuum to remove chips and debris from the working surfaces of the drill press. Never blow off the drill press with compressed air, as this will force metal chips deep into the mechanisms and may cause injury to yourself or bystanders.

Remove any rust build-up from unpainted cast iron surfaces of your drill press and treat with a non-staining lubricant after cleaning.

Keep unpainted cast iron surfaces rust-free with regular applications of ISO 68 way oil (see **Page 30** for offerings from Grizzly).



Lubrication

For the quill, table, and column, an occasional application of light machine oil is all that is necessary. Before applying lubricant, clean off any dust or metal chips.

Your goal is to achieve adequate lubrication. Too much lubrication will attract dirt and dust. Various parts of your machine could lose their freedom of movement as a result.

Headstock Lubrication

Oil TypeModel T23963 or ISO 32 Equivalent
Oil Amount.....4³/₄ quarts
Lubrication Frequency..... Annually

The headstock uses an oil pump to lubricate the gears. For this machine, use ISO 68 machine oil. Check the oil level every day (see **Step 4**). Change oil annually.

To change oil in headstock:

1. Remove the oil fill plug on top of the machine (see **Figure 35**).

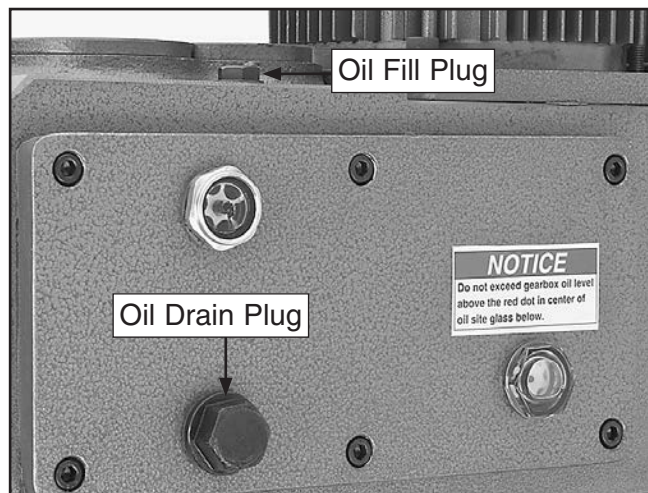

Figure 35. Oil fill and drain locations.

2. Remove the drain plug, and allow old oil to drain into an appropriate container.
3. Replace and tighten the drain plug.
4. Fill the headstock with oil to the red mark on the site glass (see **Figure 36**).

NOTICE

Do not fill headstock with oil above the red mark. This could damage the machine and create an overflow of oil.

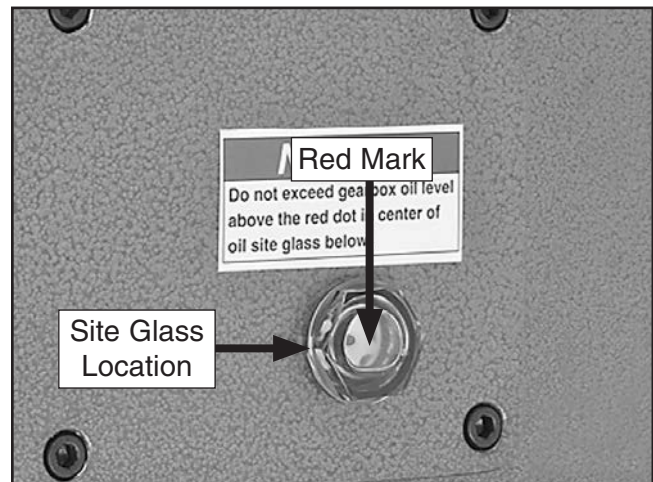

Figure 36. Site glass location.

5. Re-install the oil fill plug.
6. Discard used oil following federal, state, and fluid manufacturer guidelines for proper disposal.

Oil Flow Sight Glass

This machine comes with an oil flow sight glass (see **Figure 37**). Examine the flow sight glass during machine operation to ensure that the oil is properly circulating within the headstock.

If oil is not circulating, and headstock has proper amount of oil, shut down machine immediately and call tech support.

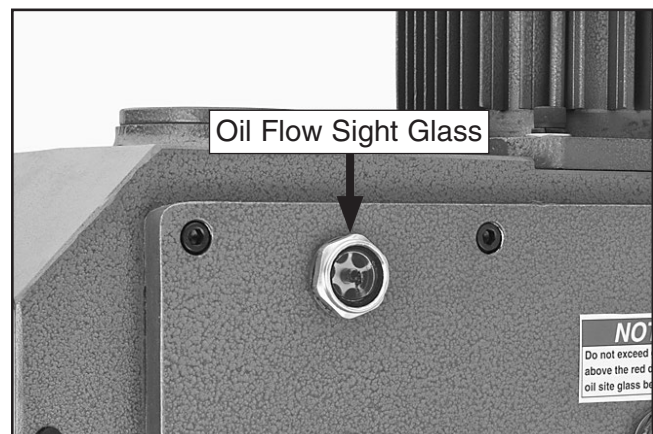

Figure 37. Oil flow sight glass.



Ball Oilers

Oil TypeModel T23963 or ISO 32 Equivalent
Oil Amount..... 1–2 Pumps
Lubrication Frequency8 Hours of Operation

This machine has four ball oilers as shown in **Figures 38–39**. Use an oil gun fitted with a rubber tip wide enough to seal the ball oiler inlet. We do not recommend using metal needle or lance tips, as they can push the ball too far into the oiler, break the spring seat, and lodge the ball in the oil galley.

Push the tip of the oil can nozzle against the ball oiler to create a hydraulic seal, then pump the oil can once or twice. If you see sludge and contaminants coming out of the lubrication area, continue pumping the oil can until the oil runs clear. When finished, wipe away the excess oil.

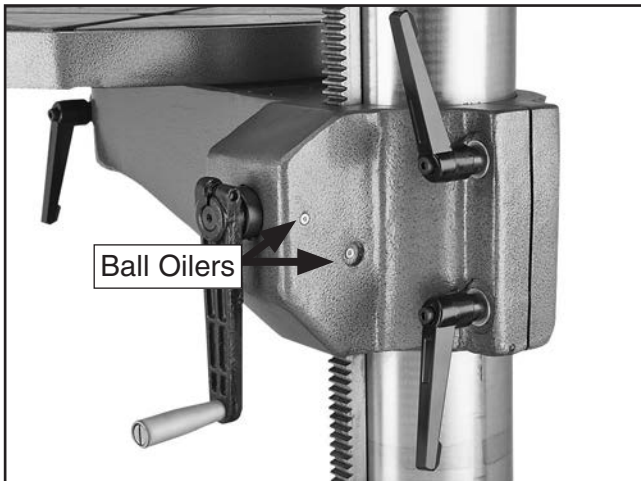

Figure 38. Table support bracket ball oiler locations.

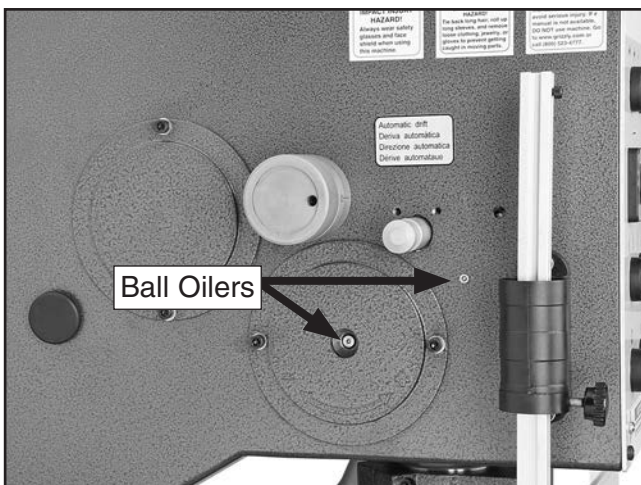

Figure 39. Headstock side ball oiler locations

Changing Coolant

Coolant is consistently cycled and stored in the base reservoir beneath the pump. For efficient operation and tool longevity, replace coolant when it runs low or becomes dirty from excessive use.

! WARNING

BIOLOGICAL & POISON HAZARD!

Use the correct personal protection equipment when handling coolant. Follow federal, state, and fluid manufacturer requirements for proper disposal.

To replace the coolant:

1. Pump coolant into an empty 5-gallon bucket. As soon as coolant stops coming out, shut off pump.
2. **DISCONNECT MACHINE FROM POWER!**
3. Put on gloves, safety glasses, and respirator. Loosen the cap screws and remove the reservoir lid (see **Figure 40**).

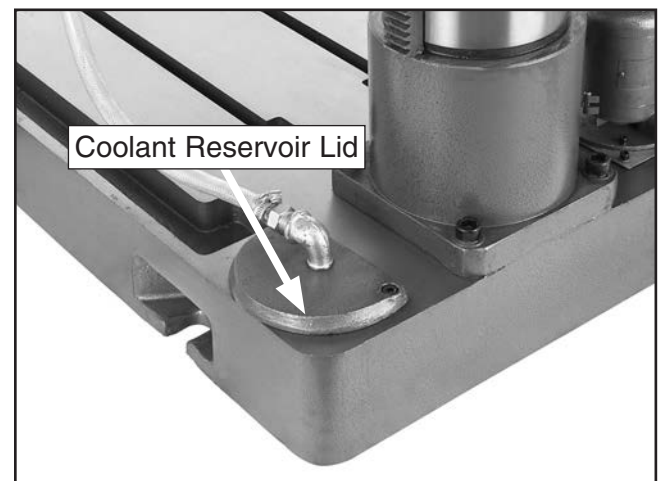

Figure 40. Coolant reservoir.

4. Use a wet/dry shop vacuum to remove any coolant and debris from inside the reservoir.
5. Refill the reservoir with fresh coolant.
6. Replace the reservoir lid and re-tighten the cap screws.



SECTION 7: SERVICE

Review the troubleshooting and procedures in this section if a problem develops with your machine. If you need replacement parts or additional help with a procedure, call our Technical Support at (570) 546-9663.

Note: Please gather the serial number and manufacture date of your machine before calling.

Troubleshooting

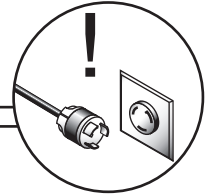

Motor & Electrical

Symptom	Possible Cause	Possible Solution
Machine does not start or a breaker trips	<ol style="list-style-type: none"> Emergency stop push-button engaged/at fault. Chuck guard open/safety switch at fault. Spindle position limit switch engaged/at fault. Power supply switched OFF or at fault. Plug/receptacle at fault/wired wrong. Motor connection wired wrong. Wall circuit breaker tripped. Wiring open/has high resistance. Master power switch at fault. Motor or motor components at fault. 	<ol style="list-style-type: none"> Rotate button to reset/replace it. Close guard/replace switch. Adjust spindle position to disengage limit switch; replace switch. Ensure power supply is on/has correct voltage. Test for good contacts; correct the wiring. Correct motor wiring connections (Page 41). Ensure circuit size is correct/replace weak breaker. Check/fix broken, disconnected, or corroded wires. Replace switch. Test/repair/replace.
Machine stalls or is overloaded.	<ol style="list-style-type: none"> Feed rate/cutting speed too fast. Wrong tooling. Machine is undersized or tooling is incorrect for the task. Motor connection is wired incorrectly. Motor bearings are at fault. Motor has overheated. Motor or motor components at fault. 	<ol style="list-style-type: none"> Decrease feed rate/cutting speed. Use the correct tool for the task. Use smaller or sharper tool; reduce feed rate or spindle speed; use coolant if possible. Correct motor wiring connections (Page 41). Test by rotating shaft; rotational grinding/loose shaft requires bearing replacement. Clean off motor, let cool, and reduce workload. Test/repair/replace motor.
Machine has vibration or noisy operation.	<ol style="list-style-type: none"> Excessive depth of cut. Tooling is loose or improperly installed. Machine is incorrectly anchored or sits unevenly. Motor or machine component is loose. Tooling is dull or at fault. Bit is chattering. Motor fan is rubbing on fan cover. Motor bearings are at fault. 	<ol style="list-style-type: none"> Decrease depth of cut. Make sure tooling is properly secured. Tighten/replace anchors; relocate/shim machine. Inspect/replace stripped or damaged bolts/nuts, and re-tighten with thread locking fluid. Replace/resharpen tooling. Replace/sharpen bit; index bit to workpiece; use appropriate feed rate and cutting RPM. Replace dented fan cover or damaged fan. Test by rotating shaft; rotational grinding/loose shaft requires bearing replacement.



Drill Press Operations

Symptom	Possible Cause	Possible Solution
Breaking tools or cutters.	<ol style="list-style-type: none"> 1. Spindle speed/feed rate is too fast. 2. Cutting tool getting too hot. 3. Spindle extended too far down. 	<ol style="list-style-type: none"> 1. Set spindle speed correctly (Page 25) or use a slower feed rate. 2. Use coolant or oil for appropriate application. 3. Fully retract spindle and lower headstock. This increases rigidity.
Drilling stops, but the motor still operates.	<ol style="list-style-type: none"> 1. Bit slips in chuck. 	<ol style="list-style-type: none"> 1. Tighten bit; inspect bit for burrs or other obstructions that might interfere with clamping surface.
The chuck wobbles or is loose on the spindle shaft.	<ol style="list-style-type: none"> 1. Foreign material is stuck between the arbor-to-spindle mating surface. 2. Damaged chuck or arbor. 	<ol style="list-style-type: none"> 1. Remove the arbor/chuck assembly and clean the tapered arbor and spindle mating surfaces, then reassemble. 2. Replace as necessary.
The spindle does not retract completely in the uppermost position or it binds.	<ol style="list-style-type: none"> 1. The quill shaft is gummy with metal chips and oil. 	<ol style="list-style-type: none"> 1. Clean shaft and lubricate with a light coat of oil.
The quill has excessive deflection.	<ol style="list-style-type: none"> 1. The quill bearings are worn or damaged. 2. The quill shaft is at fault. 	<ol style="list-style-type: none"> 1. Replace the bearings. 2. Replace the quill shaft.
Drill bit wobbles, holes are oversized.	<ol style="list-style-type: none"> 1. Drill bit installed incorrectly. 	<ol style="list-style-type: none"> 1. Remove drill bit and re-install.
Workpiece vibrates or chatters during operation.	<ol style="list-style-type: none"> 1. Table locks not tight. 2. Workpiece not securely clamped to table or into drill vice. 3. Spindle speed/feed rate is too fast. 4. Spindle extended too far down. 	<ol style="list-style-type: none"> 1. Tighten table release handles (Page 24). 2. Check that clamping is tight and sufficient for the job. Make sure drill vice is tight to the table. 3. Set spindle speed correctly (Page 25) or use a slower feed rate. 4. Fully retract spindle and raise table. This increases rigidity.



Replacing Lamp Bulb

The work lamp bulb in this machine is a 24V 25W two pronged halogen bulb. The replacement part number for the bulb is P0756418-1.

To replace the bulb in the work lamp:

1. DISCONNECT MACHINE FROM POWER!
2. Using a Phillips head screwdriver, remove the three screws that hold the work lamp cover in place.
3. Remove the bulb (see **Figure 41**).



Figure 41. Work lamp bulb replacement.

4. Insert the new bulb and replace the work lamp cover.

Torque Limiter

The torque limiter regulates how much torque is applied to the drive shaft of the drill press to prevent the machine from mechanical overload. It was adjusted at the factory according to the maximum axial load.

Eventual wear on the limiter discs may require compensatory adjustment to the torque limiter.

NOTICE

Overtightening can break the torque limiter. Make less than quarter turn adjustments at one time.

To adjust the torque limiter:

1. DISCONNECT MACHINE FROM POWER!
2. Remove the two cap screws that hold the plastic cover on the side of the headstock.
3. Rotate the spindle by hand until the set screw on the torque limiter is visible (see **Figure 42**).

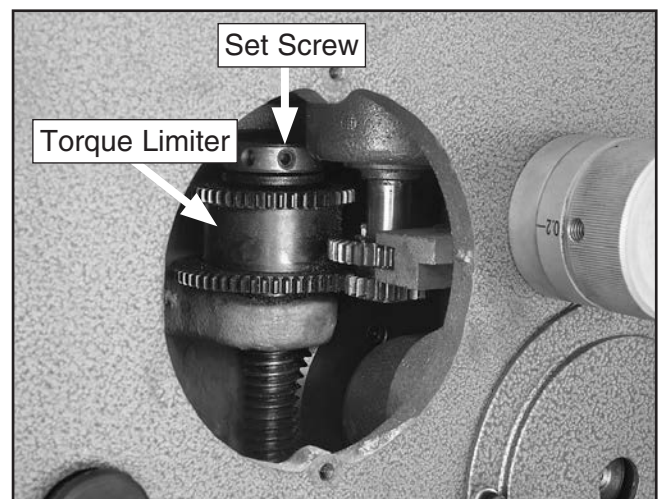

Figure 42. Torque limiter and set screw.

4. Turn the set screw less than a quarter of a turn using a 4mm hex wrench. One small adjustment should compensate for any wear on the limiter disc.



SECTION 8: WIRING

These pages are current at the time of printing. However, in the spirit of improvement, we may make changes to the electrical systems of future machines. Compare the manufacture date of your machine to the one stated in this manual, and study this section carefully.

If there are differences between your machine and what is shown in this section, call Technical Support at (570) 546-9663 for assistance BEFORE making any changes to the wiring on your machine. An updated wiring diagram may be available. **Note:** Please gather the serial number and manufacture date of your machine before calling. This information can be found on the main machine label.

WARNING

Wiring Safety Instructions

SHOCK HAZARD. Working on wiring that is connected to a power source is extremely dangerous. Touching electrified parts will result in personal injury including but not limited to severe burns, electrocution, or death. Disconnect the power from the machine before servicing electrical components!

MODIFICATIONS. Modifying the wiring beyond what is shown in the diagram may lead to unpredictable results, including serious injury or fire. This includes the installation of unapproved after-market parts.

WIRE CONNECTIONS. All connections must be tight to prevent wires from loosening during machine operation. Double-check all wires disconnected or connected during any wiring task to ensure tight connections.

CIRCUIT REQUIREMENTS. You MUST follow the requirements at the beginning of this manual when connecting your machine to a power source.

WIRE/COMPONENT DAMAGE. Damaged wires or components increase the risk of serious personal injury, fire, or machine damage. If you notice that any wires or components are damaged while performing a wiring task, replace those wires or components.

MOTOR WIRING. The motor wiring shown in these diagrams is current at the time of printing but may not match your machine. If you find this to be the case, use the wiring diagram inside the motor junction box.















CAPACITORS/INVERTERS. Some capacitors and power inverters store an electrical charge for up to 10 minutes after being disconnected from the power source. To reduce the risk of being shocked, wait at least this long before working on capacitors.

EXPERIENCING DIFFICULTIES. If you are experiencing difficulties understanding the information included in this section, contact our Technical Support at (570) 546-9663.

NOTICE

The photos and diagrams included in this section are best viewed in color. You can view these pages in color at www.grizzly.com.

COLOR KEY

BLACK		BLUE		YELLOW		LIGHT BLUE	
WHITE		BROWN		YELLOW GREEN		BLUE WHITE	
GREEN		GRAY		PURPLE		TURQUOISE	
RED		ORANGE		PINK			



Wiring Overview

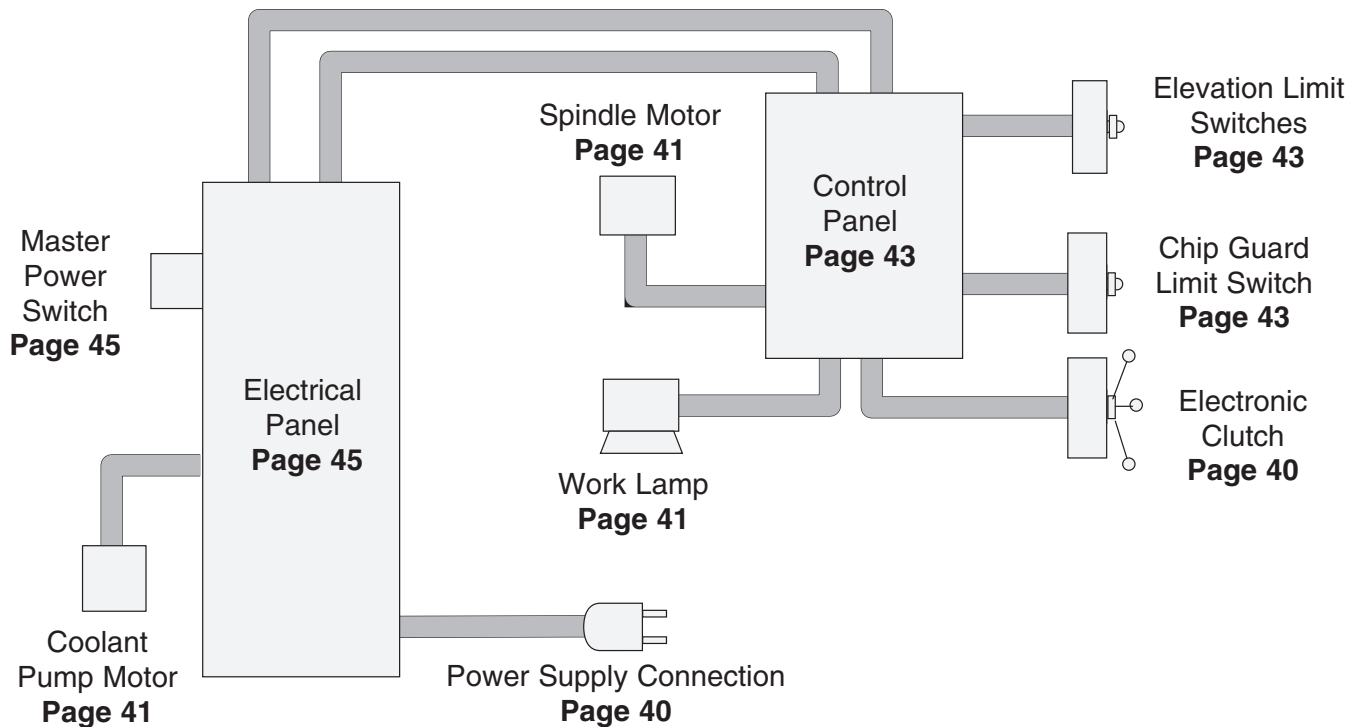

Component Location Index

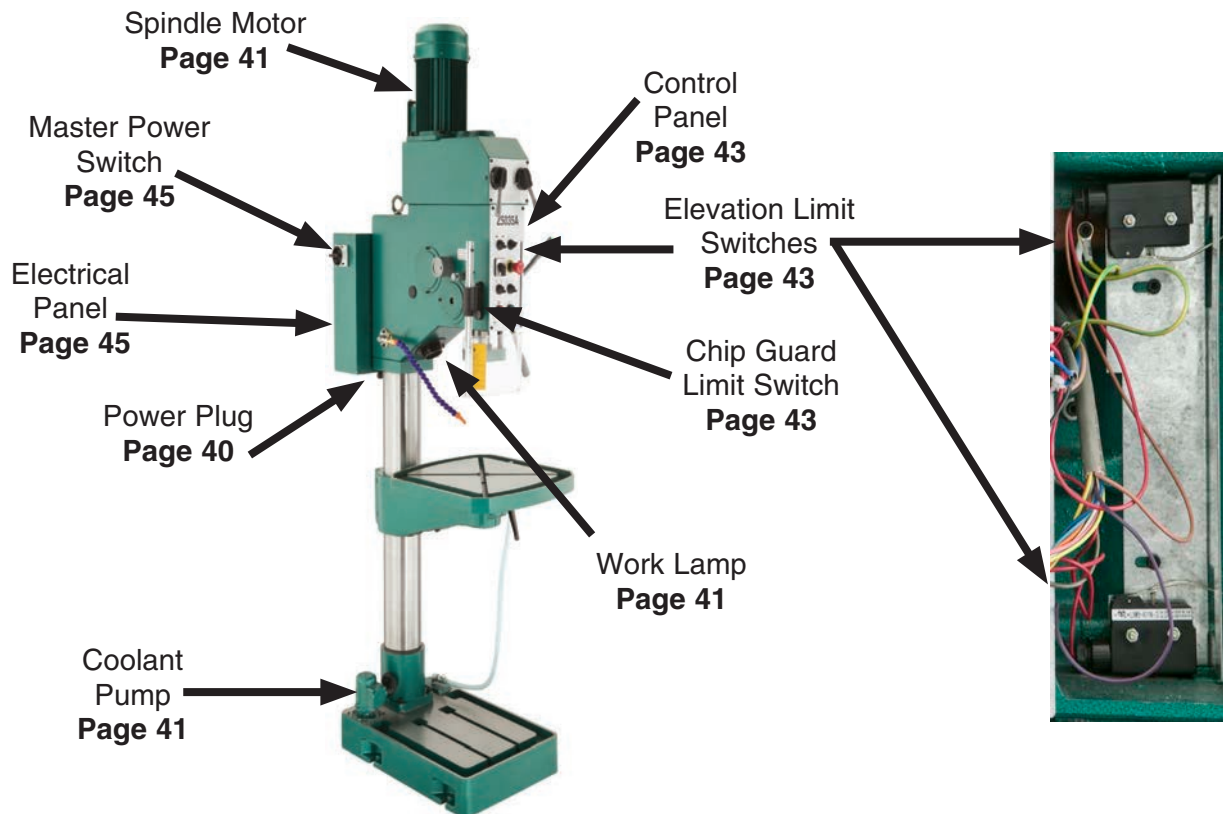

Power Connection Wiring

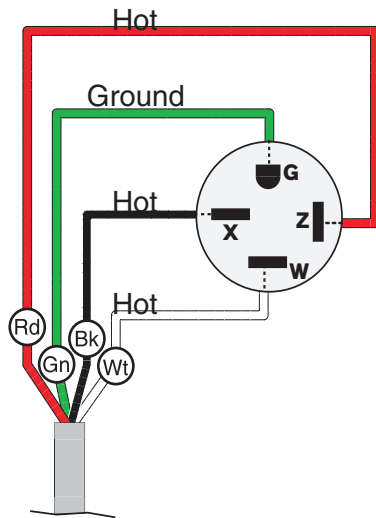

**220 VAC
3-Phase
15-15 Plug
(as recommended)**

Electric Clutch Wiring

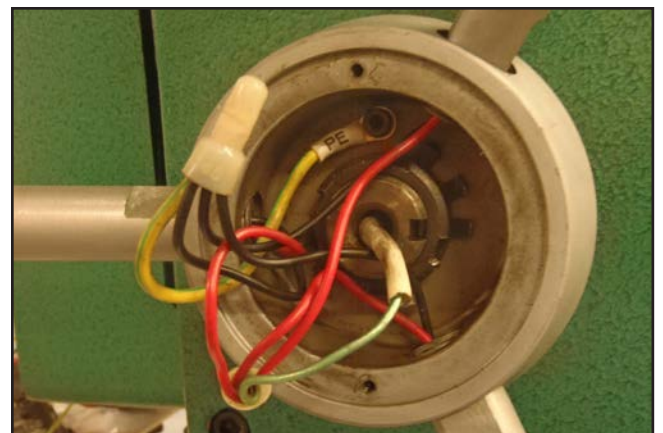
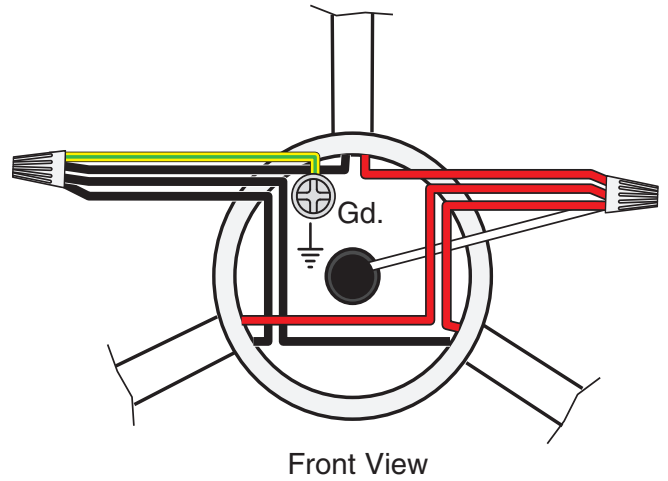
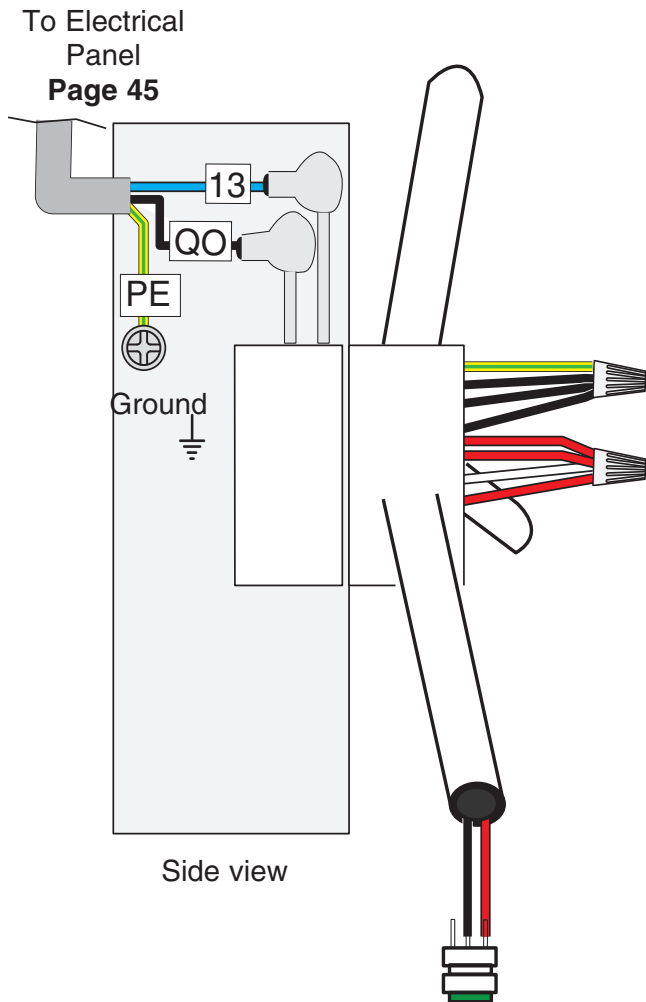

Figure 43. Electronic clutch wiring.



Motor & Pump Wiring

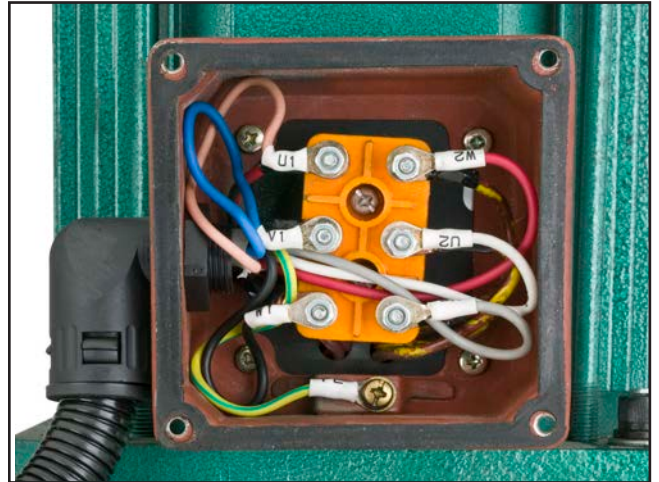
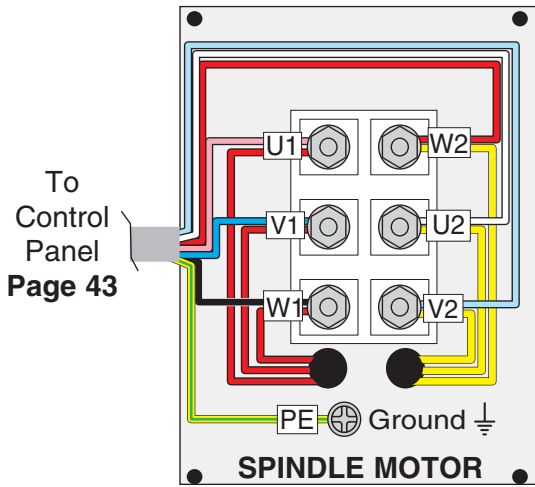

Figure 44. Spindle motor wiring.

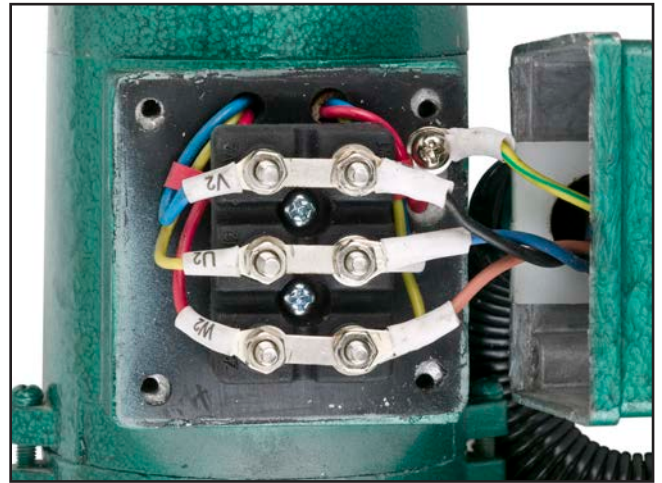
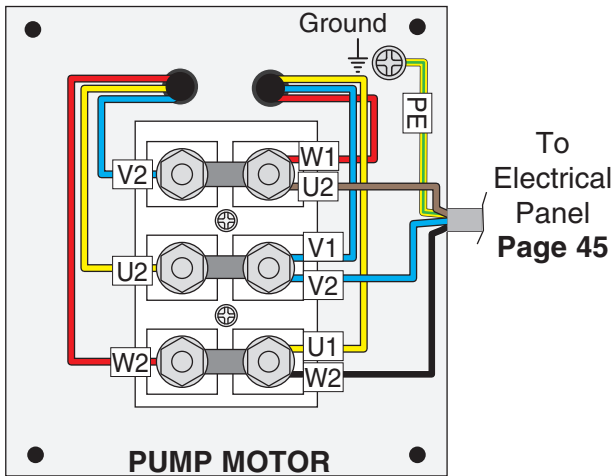

Figure 45. Coolant pump wiring.

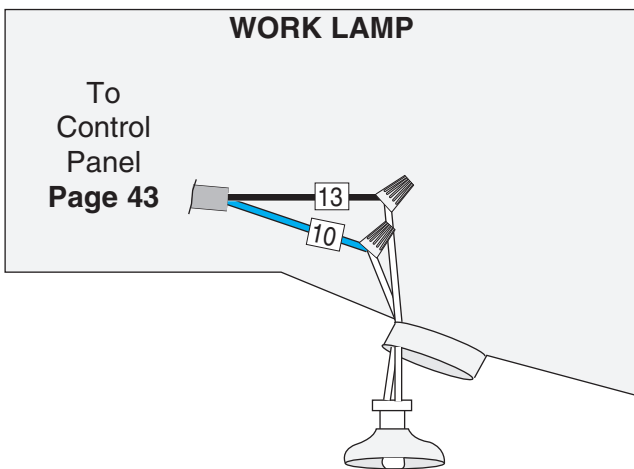

Figure 46. Work lamp wiring.

Control Panel

To Lamp
Page 41

To Electrical Panel
Page 45

To Electrical Panel
Page 45

To Spindle Motor
Page 41

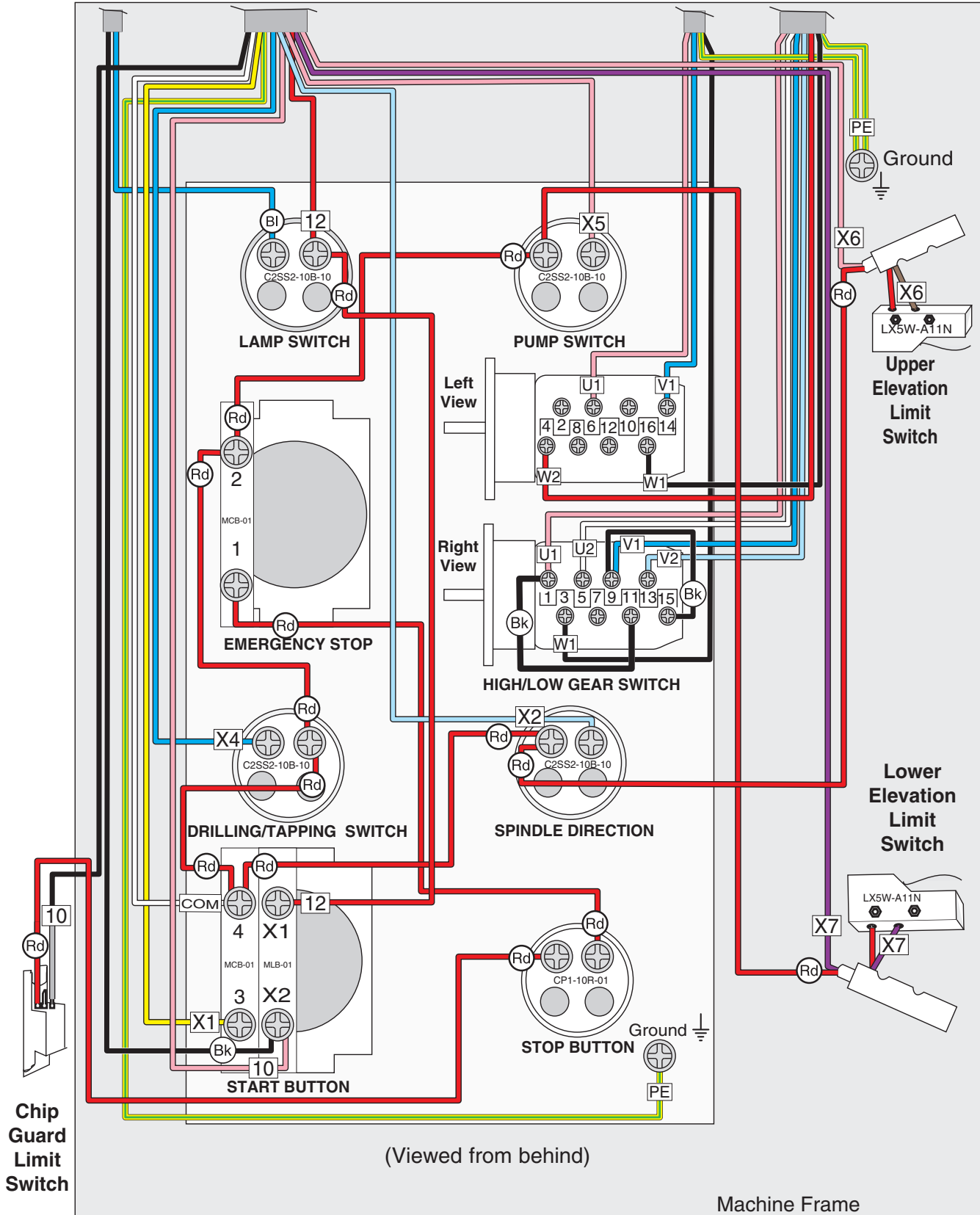

Control Panel & Limit Switches

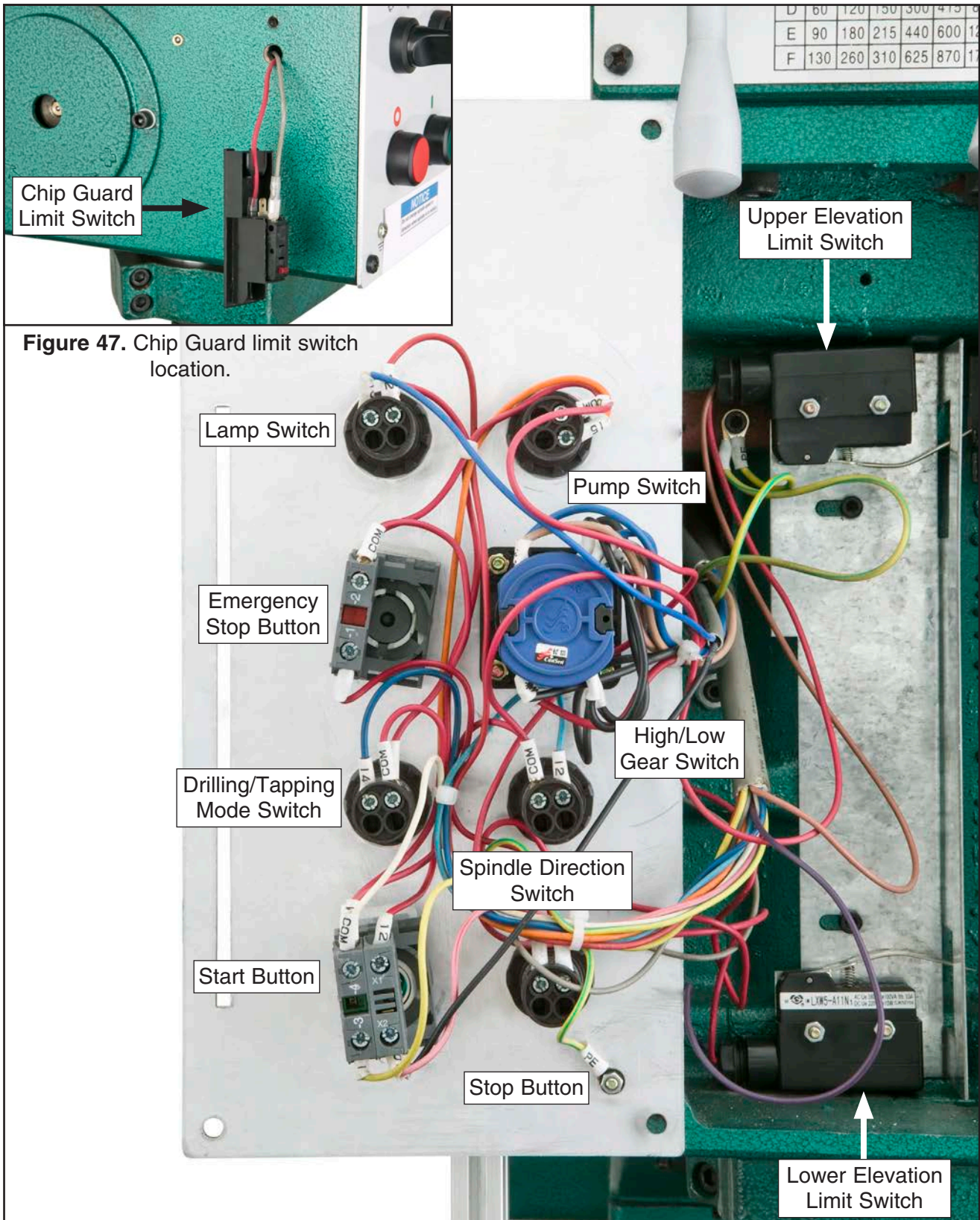
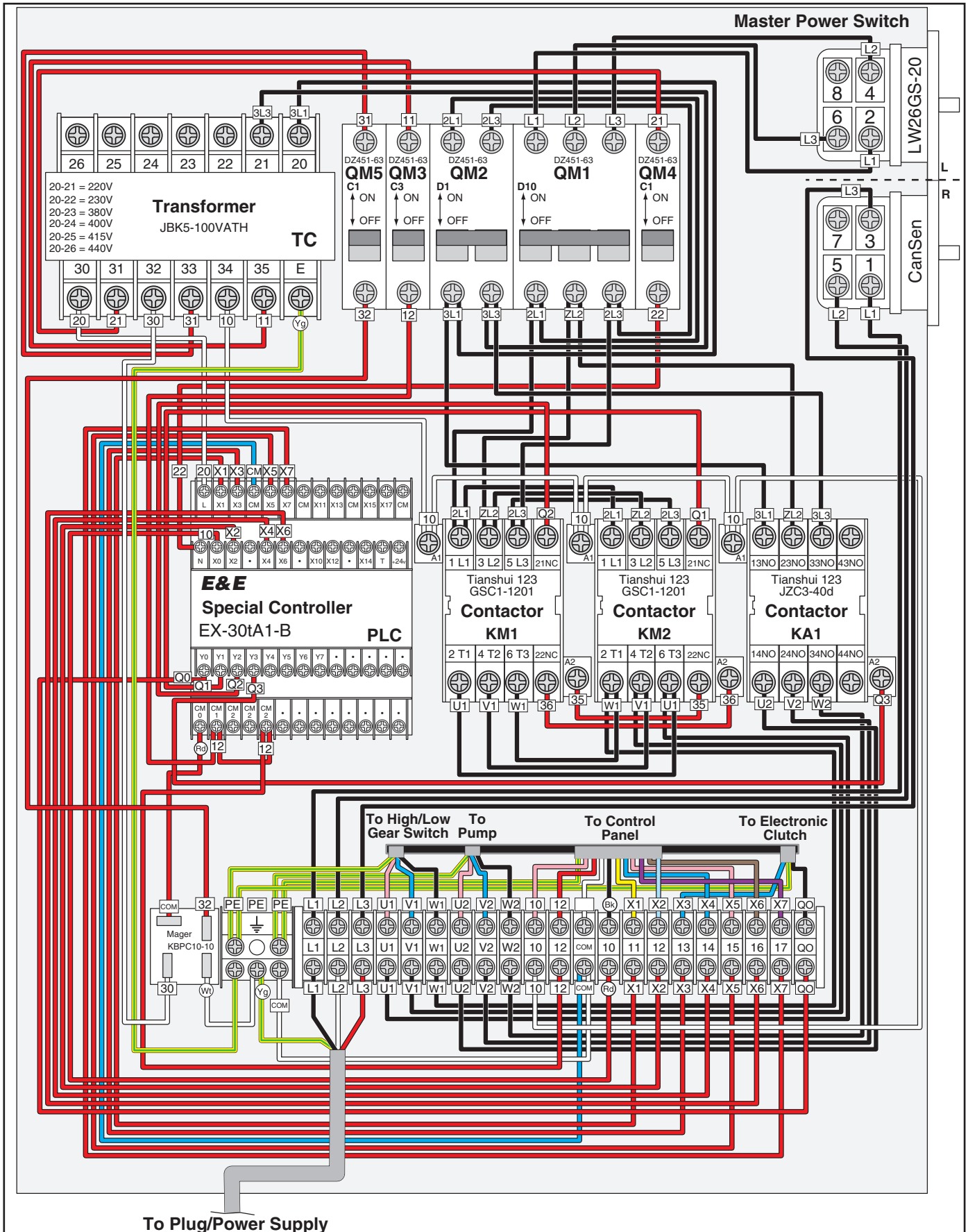

Figure 47. Chip Guard limit switch location.

Figure 31. Control panel and limit switch locations (viewed from behind).



Electrical Panel Wiring



Electrical Wiring Panel Photo

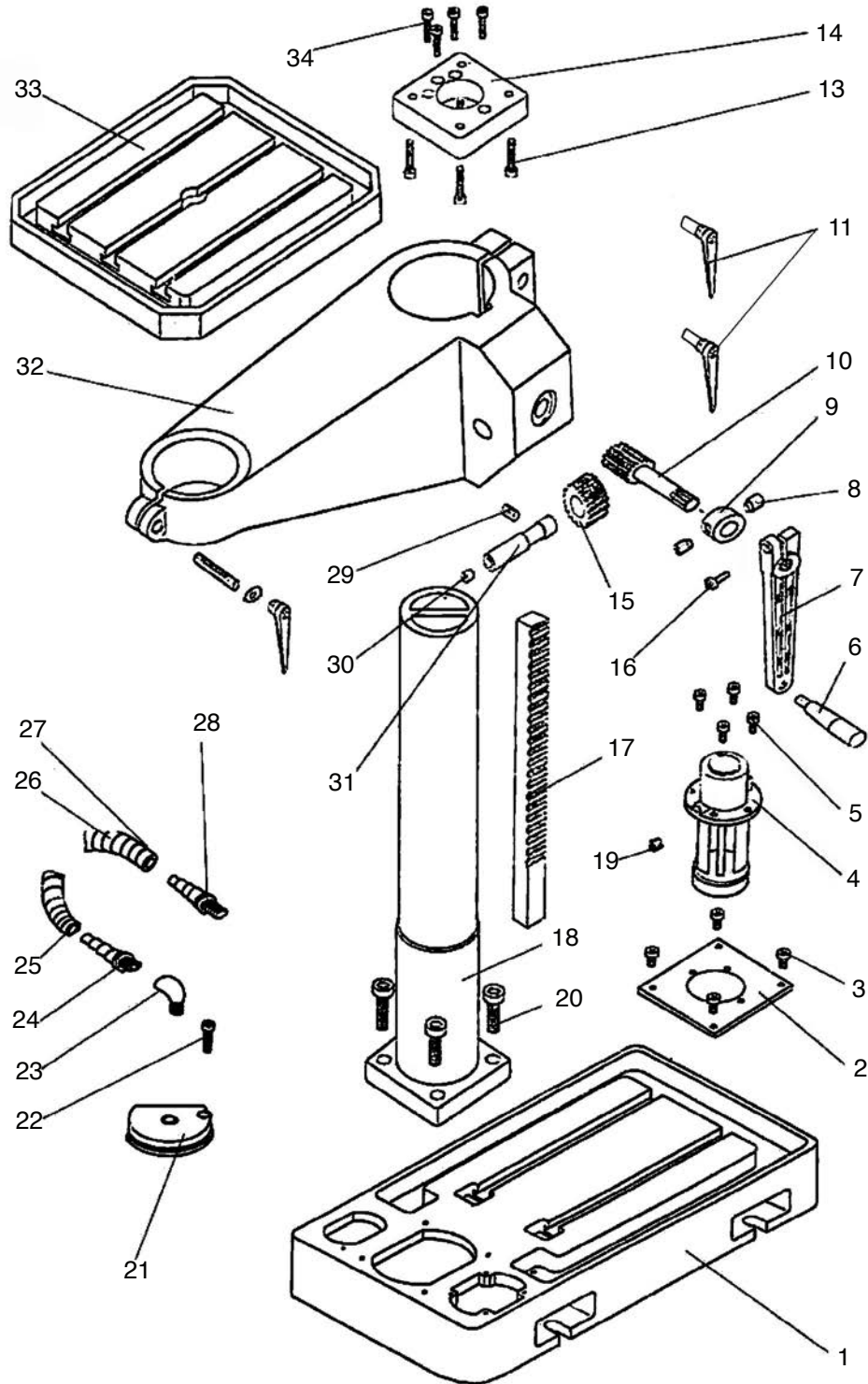

Figure 48. Electrical wiring panel.



SECTION 9: PARTS

Table Support & Coolant Breakdown



Please Note: We do our best to stock replacement parts whenever possible, but we cannot guarantee that all parts shown here are available for purchase. Call (800) 523-4777 or visit our online parts store at www.grizzly.com to check for availability.



Table Support & Coolant Parts List

REF	PART #	DESCRIPTION
1	P0756001	BASE
2	P0756002	COOLANT PUMP MOUNT
3	PCAP26M	CAP SCREW M6-1 X 12
4	P0756004	COOLANT PUMP
5	PCAP26M	CAP SCREW M6-1 X 12
6	P0756006	HANDLE SHAFT 3/8"-16 x 3"
7	P0756007	CRANK ARM
8	PSS127M	SET SCREW M10-1.5 X 10 PILOT
9	P0756009	CLAMP COLLAR
10	P0756010	WORM GEAR M16-2
11	P0756011	ADJUSTABLE HANDLE M16 X 114
13	PCAP49M	CAP SCREW M6-1 X 60
14	P0756014	HEADSTOCK MOUNT
15	P0756015	GEAR 15T
16	PCAP13M	CAP SCREW M8-1.25 X 30
17	P0756017	RACK
18	P0756018	COLUMN

REF	PART #	DESCRIPTION
19	P0756019	DRAIN PLUG 3/8" NPT SOCKET HEAD
20	PCAP209M	CAP SCREW M14-2 X 60
21	P0756021	COOLANT RESERVOIR COVER PLATE
22	PCAP31M	CAP SCREW M8-1.25 X 25
23	P0756023	REDUCING NIPPLE 1/2" X 3/8" NPT
24	P0756024	ELBOW
25	P0756025	FLEXIBLE TUBE 16 X 1.5 X 1300MM
26	P0756026	COOLANT RETURN HOSE
27	P0756027	COUPLING
28	P0756028	TEE
29	PSS16M	SET SCREW M8-1.25 X 10
30	PLUBE002M	BALL OILER 8MM TAP-IN
31	P0756031	GEAR SHAFT
32	P0756032	TABLE SUPPORT
33	P0756033	TABLE
34	PCAP122M	CAP SCREW M16-2 X 50



Gearbox Breakdown

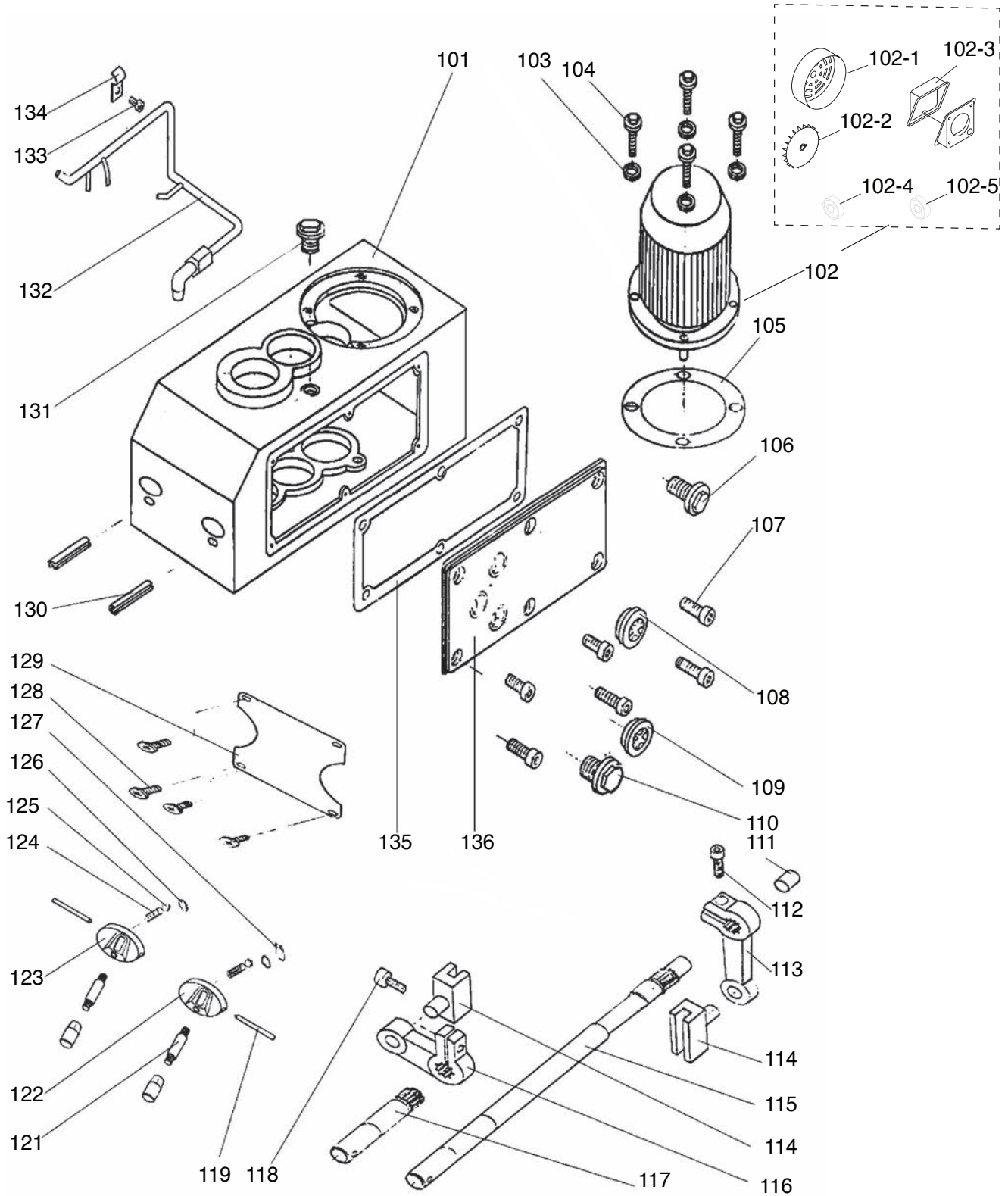

Gearbox Breakdown 2

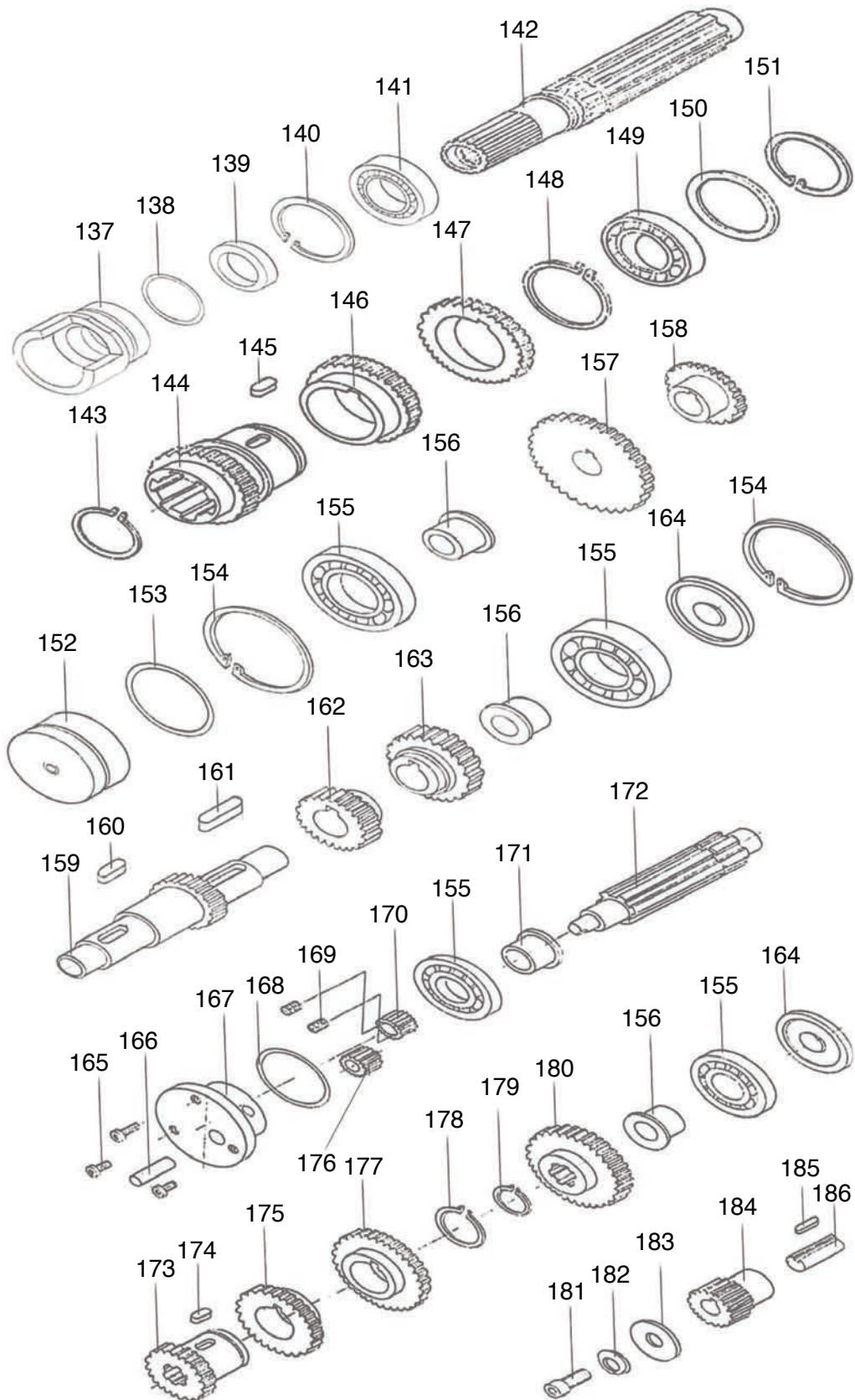

Gearbox Parts List

REF	PART #	DESCRIPTION
101	P0756101	GEARBOX HOUSING
102	P0756102	MOTOR 2HP 220V 3-PH 4/8-POLE
102-1	P0756102-1	MOTOR FAN COVER
102-2	P0756102-2	MOTOR FAN
102-3	P0756102-3	JUNCTION BOX
102-4	P0756102-4	FRONT MOTOR BEARING 6206 2RZ
102-5	P0756102-5	REAR MOTOR BEARING 6206 2RZ
103	PW04M	FLAT WASHER 10MM
104	PCAP210M	CAP SCREW M10-1.5 X 35 C12.9
105	P0756105	MOTOR GASKET
106	P0756019	DRAIN PLUG 3/8" NPT HEX HEAD
107	PCAP31M	CAP SCREW M8-1.25 X 25
108	P0756108	SIGHT GLASS M27 X 1.5
109	P0756109	SIGHT GLASS B20 x M27-1.5
110	P0756110	DRAIN PLUG M27-2 HEX HEAD
111	P0756111	PLUG
112	PCAP31M	CAP SCREW M8-1.25 X 25
113	P0756113	SHIFT LEVER
114	P0756114	SHIFT FORK
115	P0756115	SHAFT
116	P0756116	SHIFT LEVER
117	P0756117	SHAFT
118	PCAP14M	CAP SCREW M8-1.25 X 20
119	P0756119	POINTER PIN
121	P0756121	HANDLE LEVER
122	P0756122	RIGHT SHIFT HUB
123	P0756123	LEFT SHIFT HUB
124	P0756124	COMPRESSION SPRING 1 X 9 X 18-2
125	PSTB005M	STEEL BALL 10MM
126	P0756126	O-RING 17 X 1.8
127	PR09M	EXT RETAINING RING 20MM
128	PS08M	PHLP HD SCR M5-.8 X 12
129	P0756129	GEAR CHANGE PLATE
130	PRP59M	ROLL PIN 5 X 12
131	P0756019	DRAIN PLUG 3/8" NPT HEX HEAD
132	P0756132	LUBRICATION TUBE
133	PCAP03M	CAP SCREW M5-.8 X 8
134	P0756134	TUBE CLIP
135	P0756135	GEARBOX COVER GASKET
136	P0756136	GEARBOX COVER
137	P0756137	SPLINED FLANGE SLEEVE
138	P0756138	O-RING 61.5 X 3.55
139	P0756139	OIL SEAL 40 X 55 X 08MM
140	PR70M	INT RETAINING RING 68MM
141	P6008-2RS	BALL BEARING 6008-2RS

REF	PART #	DESCRIPTION
142	P0756142	SPLINED SHAFT
143	PR32M	EXT RETAINING RING 48MM
144	P0756144	GEAR 34T
145	P0756145	KEY 8 X 5 X 32
146	P0756146	GEAR 46T
147	P0756147	GEAR 40T
148	PR32M	EXT RETAINING RING 48MM
149	P6008-OPEN	BALL BEARING 6008-OPEN
150	P0756150	SPACER
151	PR38M	INT RETAINING RING 62MM
152	P0756152	COVER
153	P0756153	O-RING 58 X 2.65
154	PR38M	INT RETAINING RING 62MM
155	P6206-OPEN	BALL BEARING 6206-OPEN
156	P0756156	FLANGED BUSHING
157	P0756157	GEAR 48T
158	P0756158	GEAR 48T
159	P0756159	GEAR SHAFT
160	P0756145	KEY 8 X 5 X 32
161	P0756161	KEY 8 X 5 X 40
162	P0756162	GEAR 22T
163	P0756163	GEAR 28T
164	P0756164	COVER
165	PCAP01M	CAP SCREW M6-1 X 16
166	P0756166	DOWEL PIN 10 X 40MM
167	P0756167	FLANGE
168	P0756168	O-RING 58 X 2.65
169	PSS97M	SET SCREW M3-.5 X 4
170	P0756170	GEAR 12T
171	P0756171	FLANGED BUSHING
172	P0756172	SPLINED SHAFT
173	P0756173	GEAR 20T
174	P0756174	KEY 6 X 4 X 36
175	P0756175	GEAR 34T
176	P0756176	GEAR 12T
177	P0756177	GEAR 50T
178	PR12M	EXT RETAINING RING 35MM
179	PR11M	EXT RETAINING RING 25MM
180	P0756180	GEAR 50T
181	PCAP14M	CAP SCREW M8-1.25 X 20
182	PLW04M	LOCK WASHER 8MM
183	PWF08M	FENDER WASHER 8MM
184	P0756184	GEAR SHAFT
185	P0756185	KEY 6 X 4 X 28
186	P0756186	SHAFT



Spindle Feed Breakdown

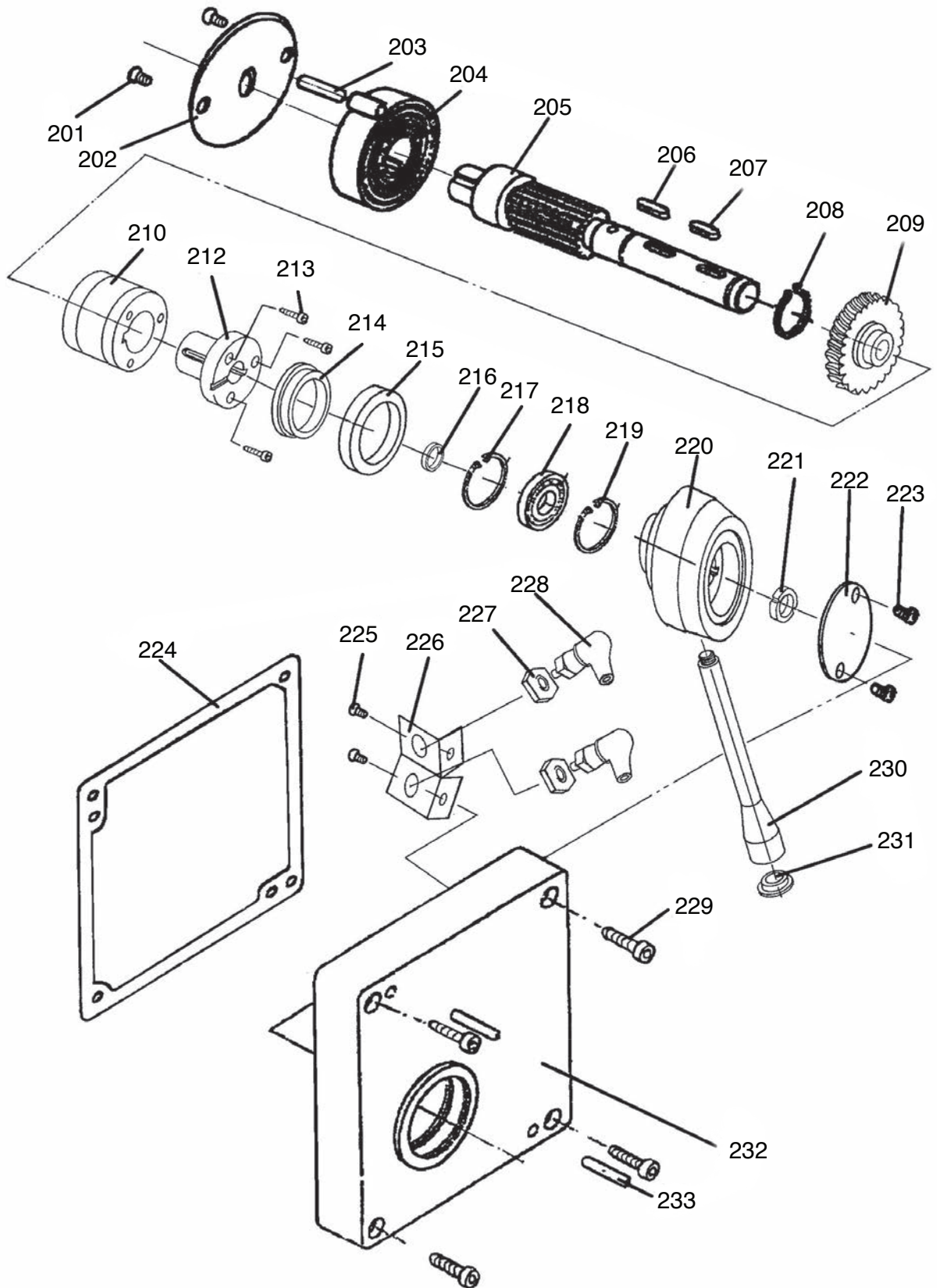

Spindle Feed Parts List

REF	PART #	DESCRIPTION
201	PS14M	PHLP HD SCR M6-1 X 12
202	P0756202	PLATE
203	PRP09M	ROLL PIN 6 X 5
204	P0756204	COILED SPRING
205	P0756205	GEAR SHAFT
206	P0756206	WOODRUFF KEY 8 X 5
207	P0756206	WOODRUFF KEY 8 X 5
208	PR73M	EXT RETAINING RING 5MM
209	P0756209	WORM GEAR
210	P0756210	ELECTROMAGNETIC TOOTH CLUTCH
212	P0756212	ARMATURE
213	PCAP16M	CAP SCREW M4-.7 X 16
214	P0756214	FLANGED BUSHING
215	P0756215	GEAR SHAFT SPACER-LARGE
216	P0756216	GEAR SHAFT SPACER-SMALL
217	PR25M	INT RETAINING RING 47MM

REF	PART #	DESCRIPTION
218	P16005-OPEN	BALL BEARING 16005-OPEN
219	PR25M	INT RETAINING RING 47MM
220	P0756220	FEED HANDLE HUB
221	P0756221	SPANNER NUT M24-1.5
222	P0756222	HUB COVER PLATE
223	PCAP110M	CAP SCREW M4-.7 X 6
224	P0756224	HEADSTOCK FEED COVER GASKET
225	PCAP110M	CAP SCREW M4-.7 X 6
226	P0756226	BRACKET
227	P0756227	NUT
228	P0756228	BRUSH
229	PCAP12M	CAP SCREW M8-1.25 X 40
230	P0756230	HANDLE SHAFT W/BUTTON HOUSING
231	P0756231	BUTTON RETAINER NUT
232	P0756232	HEADSTOCK FEED SPINDLE COVER
233	PRP86M	ROLL PIN 8 X 45



Headstock Breakdown

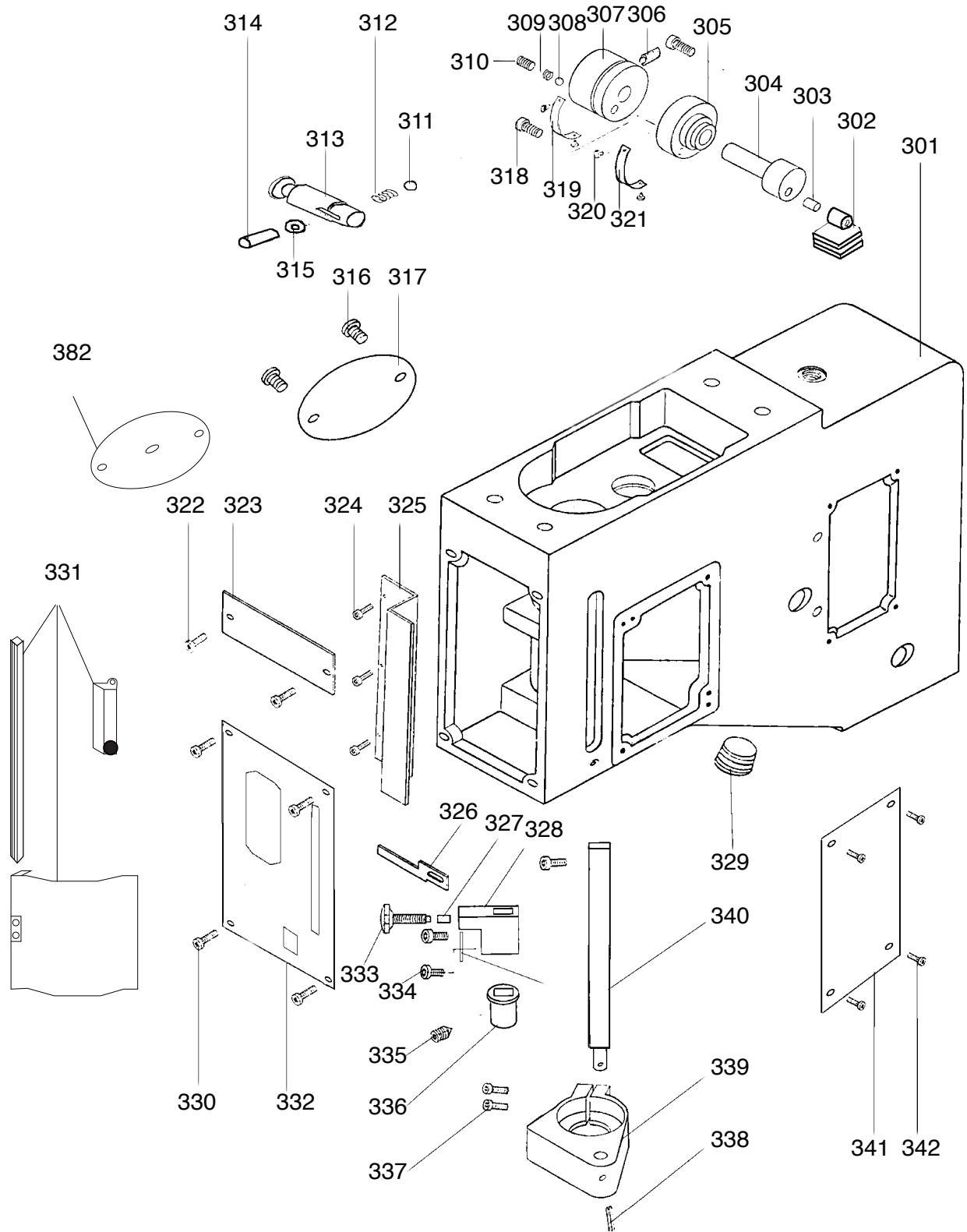

Headstock Breakdown 2

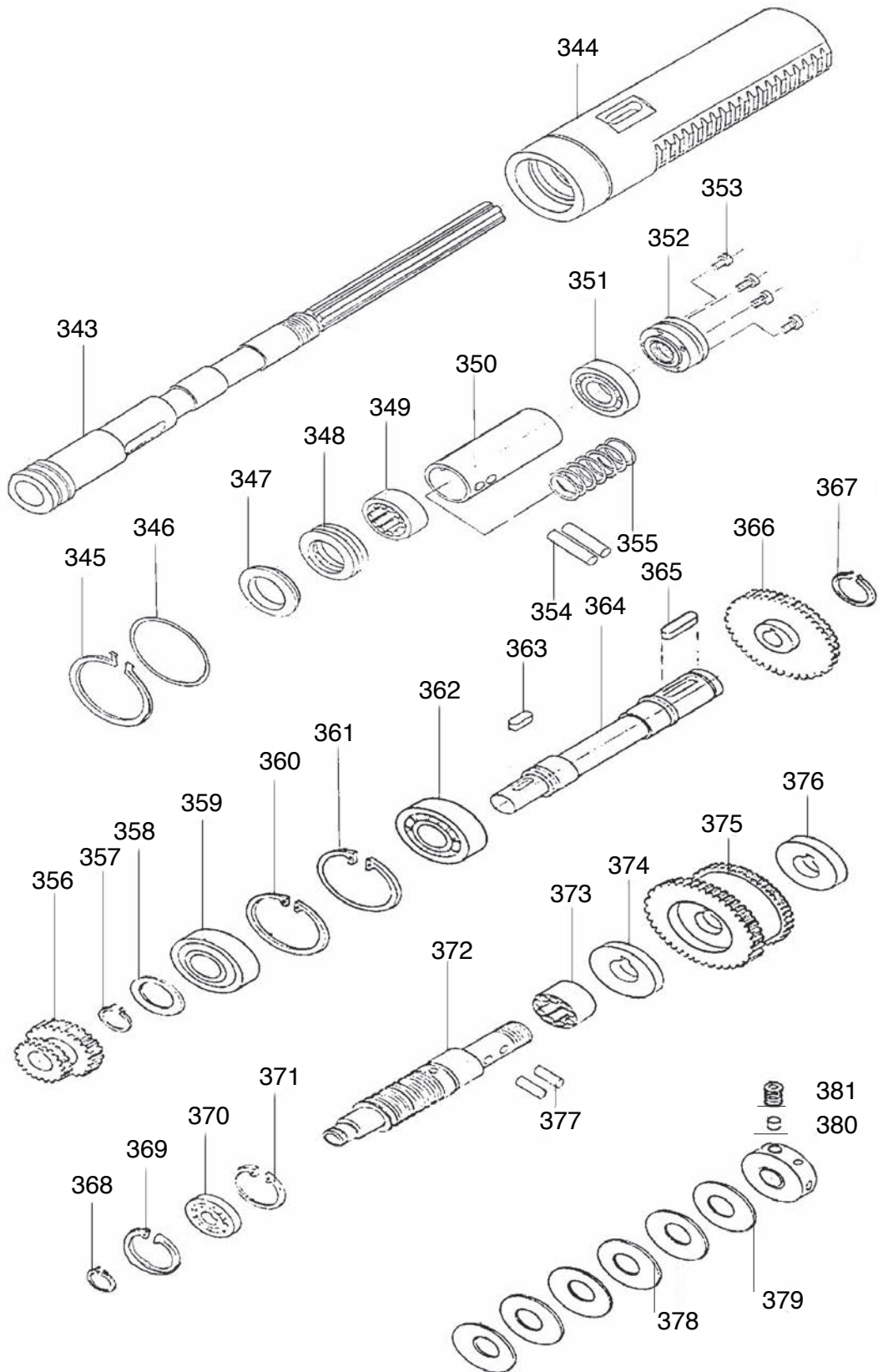

Headstock Parts List

REF	PART #	DESCRIPTION
301	P0756301	HEADSTOCK HOUSING
302	P0756302	AUTO DOWNFEED SHIFTING FORK
303	P0756303	DOWEL PIN 10 X 20MM
304	P0756304	AUTO DOWNFEED SHIFTING SHAFT
305	P0756305	AUTO DOWNFEED INDICATOR HUB
306	PSS128M	SET SCREW M8-1.25 X 25 PILOT
307	P0756307	AUTOMATIC DOWNFEED DIAL
308	PSTB003M	STEEL BALL 6MM
309	P0756309	COMPRESSION SPRING 0.8 X 5 X 16
310	PSS06M	SET SCREW M8-1.25 X 16
311	PSTB003M	STEEL BALL 6MM
312	P0756312	COMPRESSION SPRING 0.8 X 7 X 12
313	P0756313	AUTOMATIC DRIFT SHAFT
314	PSS128M	SET SCREW M8-1.25 X 25 PILOT
315	PN46M	HEX NUT M8-1.25 THIN
316	PS14M	PHLP HD SCR M6-1 X 12
317	P0756317	COILED SPRING COVER PLATE
318	PCAP02M	CAP SCREW M6-1 X 20
319	P0756319	CURVED PLATE
320	PRIV003M	STEEL FLUTED RIVET 2 X 4MM
321	P0756321	INDEX RING
322	PS14M	PHLP HD SCR M6-1 X 12
323	P0756323	PLATE
324	PCAP95M	CAP SCREW M5-.8 X 30
325	P0756325	FIREWALL PLATE
326	P0756326	SLIDE PLATE
327	P0756327	PIN
328	P0756328	BRACKET
329	P0756329	DRAIN PLUG 3/8" NPT SOCKET HEAD
330	PS14M	PHLP HD SCR M6-1 X 12
331	P0756331	CHIP GUARD ASSEMBLY
332	P0756332	CONTROL PANEL COVER PLATE
333	P0756333	STAR KNOB 5-PT M10-1.5 X 40
334	PCAP03M	CAP SCREW M5-.8 X 8
335	PSS120M	SET SCREW M6-1 X 16 CONE
336	P0756336	FLANGED COLLAR
337	PCAP12M	CAP SCREW M8-1.25 X 40
338	PRP16M	ROLL PIN 3 X 25
339	P0756339	QUILL COLLAR
340	P0756340	QUILL COLLAR SHAFT
341	P0756341	TORQUE LIMITER COVER PLATE
342	PS14M	PHLP HD SCR M6-1 X 12

REF	PART #	DESCRIPTION
343	P0756343	SPINDLE
344	P0756344	QUILL
345	PR97M	EXT RETAINING RING 75MM
346	P0756346	O-RING 85 X 5.7
347	P0756347	THRUST WASHER
348	P51108	THRUST BEARING 51108
349	P0756349	NEEDLE ROLLER BEARING RNA49/32
350	P0756350	SPRING HOUSING
351	P6006-2RS	BALL BEARING 6006-2RS
352	P0756352	CLAMP NUT
353	PCAP41M	CAP SCREW M4-.7 X 14
354	P0756354	DOWEL PIN 12 X 50MM
355	P0756355	COMPRESSION SPRING
356	P0756356	GEAR 32/20T
357	PR11M	EXT RETAINING RING 25MM
358	P0756358	BEARING FLAT WASHER
359	P6205-2RS	BALL BEARING 6205-2RS
360	PR26M	INT RETAINING RING 52MM
361	PR26M	INT RETAINING RING 52MM
362	P6205-2RS	BALL BEARING 6205-2RS
363	P0756363	WOODRUFF KEY 6 X 18
364	P0756364	SHAFT
365	P0756365	WOODRUFF KEY 6 X 12
366	P0756366	GEAR 22T
367	PR11M	EXT RETAINING RING 25MM
368	PR12M	EXT RETAINING RING 35MM
369	PR29M	INT RETAINING RING 32MM
370	P6002-2RS	BALL BEARING 6002-2RS
371	PR29M	INT RETAINING RING 32MM
372	P0756372	WORM
373	P0756373	NEEDLE ROLLER BEARING MF-2516
374	P0756374	KEYED SPACER
375	P0756375	GEAR 48/60T
376	P0756376	KEYED SPACER
377	P0756377	DOWEL PIN 6 X 8MM
378	P0756378	DISC SPRING 45 X 24 X 1.75
379	P0756379	CLAMP NUT
380	P0756380	PLUNGER
381	PSS20M	SET SCREW M8-1.25 X 8
382	P0756382	ROUND COVER PLATE W/ LUBE HOLE



Electrical Parts Breakdown

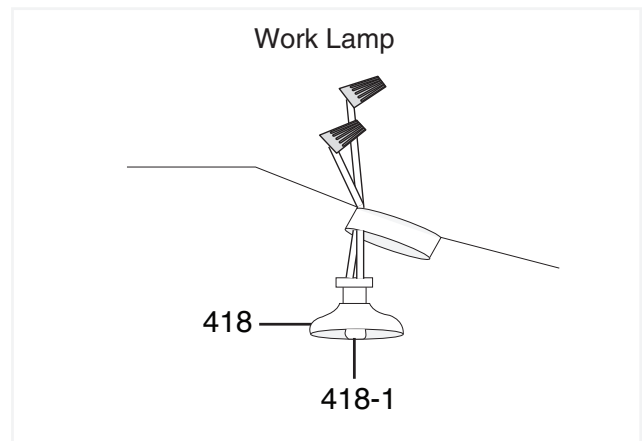
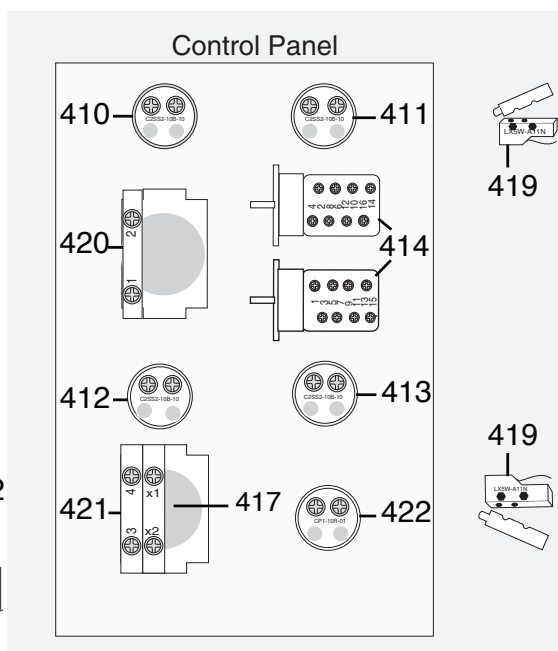
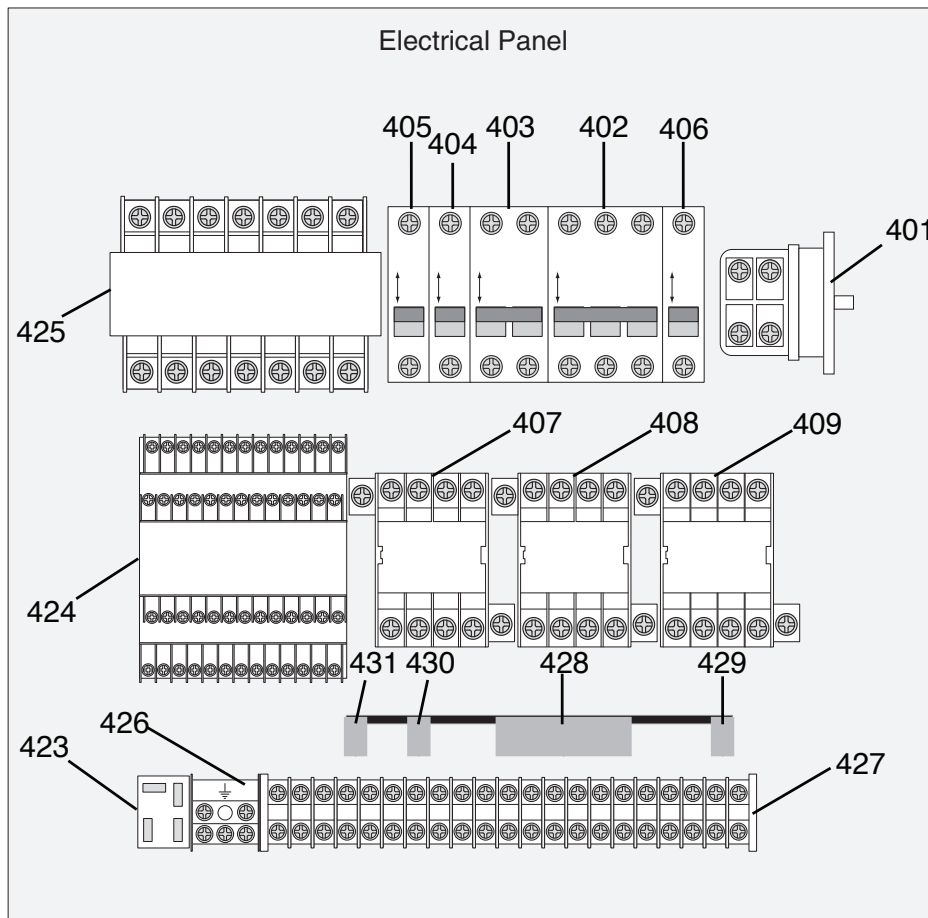

Electrical Parts List

REF PART # DESCRIPTION

401	P0756401	ROTARY SWITCH CANSEN LW26GS-20 4P
402	P0756402	CIRCUIT BREAKER HUILONG DZ451-63 D10 3P
403	P0756403	CIRCUIT BREAKER HUILONG DZ451-63 D1 2P
404	P0756404	CIRCUIT BREAKER HUILONG DZ451-63 C3 1P
405	P0756405	CIRCUIT BREAKER HUILONG DZ451-63 C1 1P
406	P0756405	CIRCUIT BREAKER HUILONG DZ451-63 C1 1P
407	P0756407	CONTACTOR TIANSHUI GSC-1201 24V
408	P0756407	CONTACTOR TIANSHUI GSC-1201 24V
409	P0756409	CONTACTOR TIANSHUI JZC3-40D 24V
410	P0756410	SELECTOR SWITCH ABB C2SS2-10B-10
411	P0756410	SELECTOR SWITCH ABB C2SS2-10B-10
412	P0756410	SELECTOR SWITCH ABB C2SS2-10B-10
413	P0756410	SELECTOR SWITCH ABB C2SS2-10B-10
414	P0756414	H/L ROTARY SWITCH CANSEN LW26-20 16P
417	P0756417	POWER LIGHT LA58-XD
418	P0756418	HALOGEN WORK LAMP 24V 25W

REF PART # DESCRIPTION

418-1	P0756418-1	HALOGEN BULB 50W 24V BI-PIN
419	P0756419	LIMIT SWITCH LXW5-A11N
420	P0756420	E-STOP BUTTON 22MM ABB MCB-01
421	P0756421	GRN BUTTON ABB 800FP-F3 MCB-10(2)
422	P0756422	RED BUTTON ABB CP1-10R-01
423	P0756423	BRIDGE RECTIFIER KBP1010
424	P0756424	CONTROLLER E&E EX-30A1-B
425	P0756425	TRANSFORMER JBK5-100VATH
426	P0756426	GROUNDING BLOCK
427	P0756427	TERMINAL BAR 21P
428	P0756428	CONTROL PANEL WIRING HARNESS
429	P0756429	ELEC CLUTCH WIRING HARNESS
430	P0756430	PUMP WIRING HARNESS
431	P0756431	H/L SWITCH WIRING HARNESS
432	P0756432	CHIP GUARD LIMIT SWITCH



Labels & Cosmetics

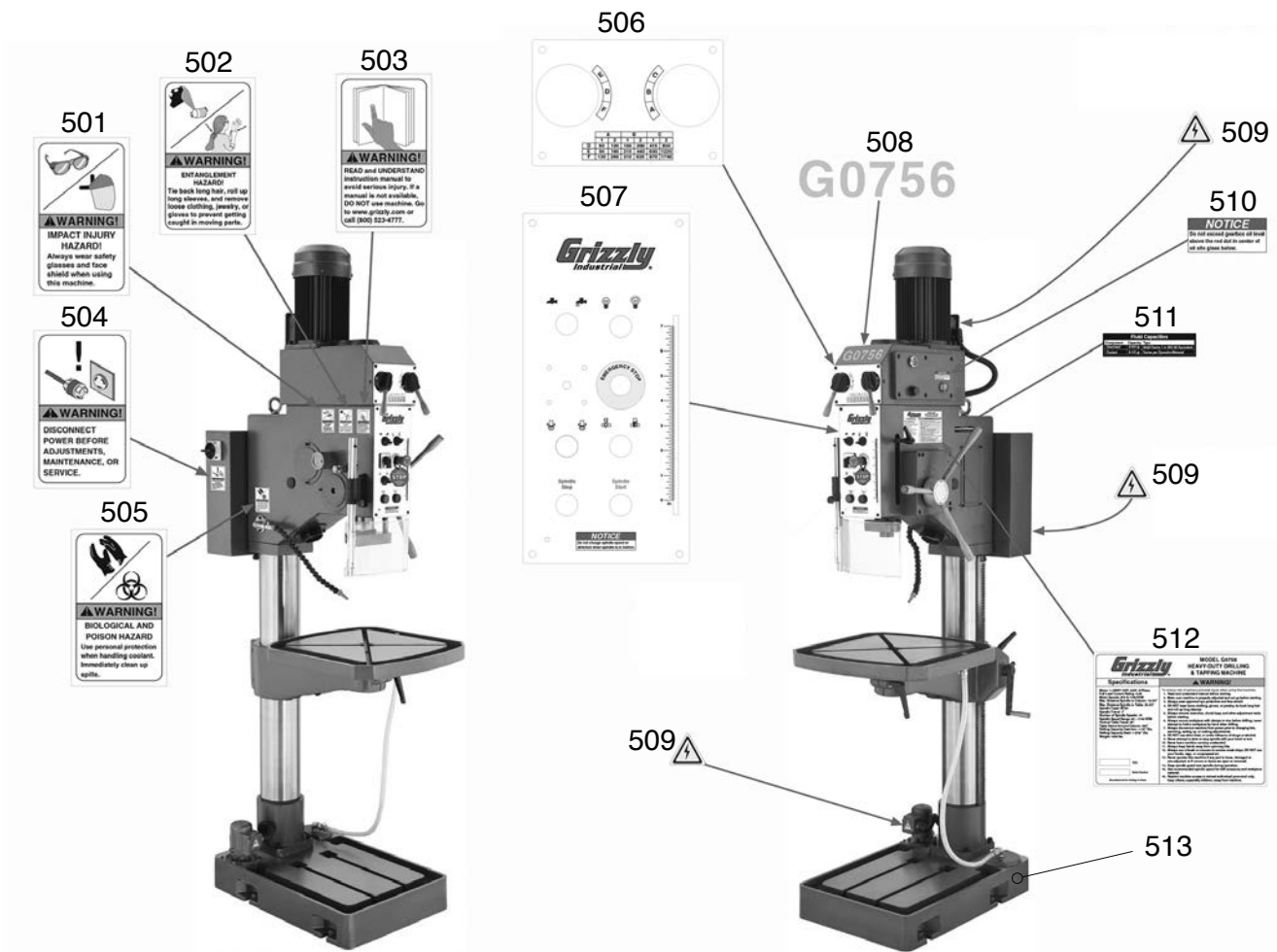

REF PART #	DESCRIPTION
501	P0756501 GLASSES FACE SHIELD LABEL 2"W X 3.3"H
502	PLABEL-55 ENTANGLEMENT LABEL 2"W X 3.3"H
503	PLABEL-12A READ MANUAL LABEL 2"W X 3.3"H
504	PLABEL-63 DISCONNECT POWER LABEL 2"W X 3.3"H
505	PLABEL-50 COOLANT HAZARD LABEL 2"W X 3.3"H
506	P0756506 GEARBOX SPEEDS LABEL
507	P0756507 CONTROL PANEL LABEL

REF PART #	DESCRIPTION
508	P0756508 MODEL NUMBER LABEL
509	PLABEL-14 ELECTRICITY LABEL 1.4"W X 1.2"H
510	P0756510 GEARBOX OIL LEVEL NOTICE
511	P0756511 FLUID CAPACITIES LABEL
512	P0756512 MACHINE ID LABEL
513	PPAINT-1 GRIZZLY GREEN TOUCH-UP PAINT

⚠️ WARNING

Safety labels help reduce the risk of serious injury caused by machine hazards. If any label comes off or becomes unreadable, the owner of this machine **MUST** replace it in the original location before resuming operations. For replacements, contact (800) 523-4777 or www.grizzly.com.





WARRANTY CARD

Name _____
 Street _____
 City _____ State _____ Zip _____
 Phone # _____ Email _____
 Model # _____ Order # _____ Serial # _____

The following information is given on a voluntary basis. It will be used for marketing purposes to help us develop better products and services. **Of course, all information is strictly confidential.**

1. How did you learn about us?

Advertisement Friend Catalog
 Card Deck Website Other:

2. Which of the following magazines do you subscribe to?

<input type="checkbox"/> Cabinetmaker & FDM	<input type="checkbox"/> Popular Science	<input type="checkbox"/> Wooden Boat
<input type="checkbox"/> Family Handyman	<input type="checkbox"/> Popular Woodworking	<input type="checkbox"/> Woodshop News
<input type="checkbox"/> Hand Loader	<input type="checkbox"/> Precision Shooter	<input type="checkbox"/> Woodsmith
<input type="checkbox"/> Handy	<input type="checkbox"/> Projects in Metal	<input type="checkbox"/> Woodwork
<input type="checkbox"/> Home Shop Machinist	<input type="checkbox"/> RC Modeler	<input type="checkbox"/> Woodworker West
<input type="checkbox"/> Journal of Light Cont.	<input type="checkbox"/> Rifle	<input type="checkbox"/> Woodworker's Journal
<input type="checkbox"/> Live Steam	<input type="checkbox"/> Shop Notes	<input type="checkbox"/> Other:
<input type="checkbox"/> Model Airplane News	<input type="checkbox"/> Shotgun News	
<input type="checkbox"/> Old House Journal	<input type="checkbox"/> Today's Homeowner	
<input type="checkbox"/> Popular Mechanics	<input type="checkbox"/> Wood	

3. What is your annual household income?

\$20,000-\$29,000 \$30,000-\$39,000 \$40,000-\$49,000
 \$50,000-\$59,000 \$60,000-\$69,000 \$70,000+

4. What is your age group?

20-29 30-39 40-49
 50-59 60-69 70+

5. How long have you been a woodworker/metalworker?

0-2 Years 2-8 Years 8-20 Years 20+ Years

6. How many of your machines or tools are Grizzly?

0-2 3-5 6-9 10+

7. Do you think your machine represents a good value? Yes No

8. Would you recommend Grizzly Industrial to a friend? Yes No

9. Would you allow us to use your name as a reference for Grizzly customers in your area?

Note: We never use names more than 3 times. Yes No

10. Comments: _____

CUT ALONG DOTTED LINE

FOLD ALONG DOTTED LINE



Place
Stamp
Here



GRIZZLY INDUSTRIAL, INC.
P.O. BOX 2069
BELLINGHAM, WA 98227-2069



FOLD ALONG DOTTED LINE

Send a Grizzly Catalog to a friend:

Name _____
Street _____
City _____ State _____ Zip _____

TAPE ALONG EDGES--PLEASE DO NOT STAPLE

WARRANTY & RETURNS

Grizzly Industrial, Inc. warrants every product it sells for a period of **1 year** to the original purchaser from the date of purchase. This warranty does not apply to defects due directly or indirectly to misuse, abuse, negligence, accidents, repairs or alterations or lack of maintenance. This is Grizzly's sole written warranty and any and all warranties that may be implied by law, including any merchantability or fitness, for any particular purpose, are hereby limited to the duration of this written warranty. We do not warrant or represent that the merchandise complies with the provisions of any law or acts unless the manufacturer so warrants. In no event shall Grizzly's liability under this warranty exceed the purchase price paid for the product and any legal actions brought against Grizzly shall be tried in the State of Washington, County of Whatcom.

We shall in no event be liable for death, injuries to persons or property or for incidental, contingent, special, or consequential damages arising from the use of our products.

To take advantage of this warranty, contact us by mail or phone and give us all the details. We will then issue you a "Return Number," which must be clearly posted on the outside as well as the inside of the carton. We will not accept any item back without this number. Proof of purchase must accompany the merchandise.

The manufacturers reserve the right to change specifications at any time because they constantly strive to achieve better quality equipment. We make every effort to ensure that our products meet high quality and durability standards and we hope you never need to use this warranty.

Please feel free to write or call us if you have any questions about the machine or the manual.

Thank you again for your business and continued support. We hope to serve you again soon.

grizzly.com[®]

TOOL WEBSITE

Buy Direct and Save with Grizzly[®] – Trusted, Proven and a Great Value!
~Since 1983~

*Visit Our Website Today For
Current Specials!*

**ORDER
24 HOURS A DAY!
1-800-523-4777**



Free Manuals Download Website

<http://myh66.com>

<http://usermanuals.us>

<http://www.somanuals.com>

<http://www.4manuals.cc>

<http://www.manual-lib.com>

<http://www.404manual.com>

<http://www.luxmanual.com>

<http://aubethermostatmanual.com>

Golf course search by state

<http://golfingnear.com>

Email search by domain

<http://emailbydomain.com>

Auto manuals search

<http://auto.somanuals.com>

TV manuals search

<http://tv.somanuals.com>