

**MINI DRILL PRESS**  
**MODEL G4014**  
**INSTRUCTION MANUAL**



COPYRIGHT © 1998 BY GRIZZLY INDUSTRIAL, INC.  
**WARNING: NO PORTION OF THIS MANUAL MAY BE REPRODUCED IN ANY SHAPE  
OR FORM WITHOUT THE WRITTEN APPROVAL OF GRIZZLY INDUSTRIAL, INC.**  
JUNE, 1998 PRINTED IN USA

# WARNING

Some dust created by power sanding, sawing, grinding, drilling, and other construction activities contains chemicals known to the State of California to cause cancer, birth defects or other reproductive harm. Some examples of these chemicals are:

- Lead from lead-based paints.
- Crystalline silica from bricks, cement, and other masonry products.
- Arsenic and chromium from chemically treated lumber.

Your risk from these exposures varies, depending on how often you do this type of work. To reduce your exposure to these chemicals: work in a well ventilated area, and work with approved safety equipment, such as those dust masks that are specially designed to filter out microscopic particles.

# WOODWORKING EQUIPMENT SAFETY INSTRUCTIONS

## WARNING

### For Your Own Safety Read Instruction Manual Before Operating This Equipment

Woodworking can be fun and rewarding, however it can also be a dangerous activity if safe and proper operating procedures are not followed. Please take the time to review the manual which was supplied with your machine, as well as these general safety instructions. Make sure you have properly assembled and adjusted the machine before operating it the first time. Also make certain you understand the procedures you are going to perform. Thinking through the steps or going through the motions of the operation with the machine off is often a good way to anticipate potential problems. Always use common sense and exercise caution in the workshop. If a procedure feels dangerous or awkward, don't do it!

If the instruction manual does not answer your questions, or you cannot find assistance from other woodworking books or references, please contact Grizzly Industrial's Customer Service:

Grizzly Industrial, Inc.  
1203 Lycoming Mall Circle  
Muncy, PA 17756  
Phone: (570) 546-9663  
Fax: 1-800-438-5901  
E-Mail: [techsupport@grizzly.com](mailto:techsupport@grizzly.com)  
Web Site: <http://www.grizzly.com>

## WARNING

### Safety Instructions For Power Tools

- 1. KEEP GUARDS IN PLACE** and in working order.
- 2. REMOVE ADJUSTING KEYS AND WRENCHES.** Form a habit of checking to see that keys and adjusting wrenches are removed from tool before turning on.
- 3. KEEP WORK AREA CLEAN.** Cluttered areas and benches invite accidents.
- 4. DO NOT USE IN DANGEROUS ENVIRONMENT.** DO NOT use power tools in damp or wet locations, or where any flammable or noxious fumes may exist. Keep work area well lighted.
- 5. KEEP CHILDREN AND VISITORS AWAY.** All children and visitors should be kept a safe distance from work area.
- 6. MAKE WORK SHOP CHILD PROOF** with padlocks, master switches, or by removing starter keys.
- 7. DO NOT FORCE TOOL.** It will do the job better and safer at the rate for which it was designed.
- 8. USE RIGHT TOOL.** DO NOT force tool or attachment to do a job for which it was not designed.

# WARNING

## Safety Instructions For Power Tools

9. **USE PROPER EXTENSION CORD.** Make sure your extension cord is in good condition. Conductor size should be in accordance with the chart below. The amperage rating should be listed on the motor or tool nameplate. An undersized cord will cause a drop in line voltage resulting in loss of power and overheating. Your extension cord must also contain a ground wire and plug pin. Always repair or replace extension cords if they become damaged.

Minimum Gauge for Extension Cords

AMP RATING	LENGTH		
	25ft	50ft	100ft
0-6	16	16	16
7-10	16	16	14
11-12	16	16	14
13-16	14	12	12
17-20	12	12	10
21-30	10	10	No

16. **REDUCE THE RISK OF UNINTENTIONAL STARTING.** On machines with magnetic contact starting switches there is a risk of starting if the machine is bumped or jarred. Always disconnect from power source before adjusting or servicing. Make sure switch is in OFF position before reconnecting.
17. **MANY WOODWORKING TOOLS CAN "KICKBACK" THE WORKPIECE** toward the operator if not handled properly. Know what conditions can create "kickback" and know how to avoid them. Read the manual accompanying the machine thoroughly.
18. **CHECK DAMAGED PARTS.** Before further use of the tool, a guard or other part that is damaged should be carefully checked to determine that it will operate properly and perform its intended function. Check for alignment of moving parts, binding of moving parts, breakage of parts, mounting, and any other conditions that may affect its operation. A guard or other part that is damaged should be properly repaired or replaced.
19. **NEVER LEAVE TOOL RUNNING UNATTENDED. TURN POWER OFF. DO NOT** leave tool until it comes to a complete stop.
20. **NEVER OPERATE A MACHINE WHEN TIRED, OR UNDER THE INFLUENCE OF DRUGS OR ALCOHOL.** Full mental alertness is required at all times when running a machine.

10. **WEAR PROPER APPAREL.** DO NOT wear loose clothing, gloves, neckties, rings, bracelets, or other jewelry which may get caught in moving parts. Non-slip footwear is recommended. Wear protective hair covering to contain long hair.
11. **ALWAYS USE SAFETY GLASSES.** Also use face or dust mask if cutting operation is dusty. Everyday eyeglasses only have impact resistant lenses, they are NOT safety glasses.
12. **SECURE WORK.** Use clamps or a vise to hold work when practical. It's safer than using your hand and frees both hands to operate tool.
13. **DO NOT OVERREACH.** Keep proper footing and balance at all times.
14. **MAINTAIN TOOLS WITH CARE.** Keep tools sharp and clean for best and safest performance. Follow instructions for lubricating and changing accessories.
15. **USE RECOMMENDED ACCESSORIES.** Consult the owner's manual for recommended accessories. The use of improper accessories may cause risk of injury.

### CAUTION

No list of safety guidelines can be complete. Every shop environment is different. Always consider safety first, as it applies to your individual working conditions. Use this and other machinery with caution and respect. Failure to do so could result in serious personal injury, damage to equipment or poor work results.

# Table Of Contents

	PAGE
<b>1. SAFETY</b> .....	2
SAFETY RULES FOR POWER TOOLS .....	2
ADDITIONAL SAFETY INSTRUCTIONS FOR THE MINI DRILL PRESS .....	3
<b>2. CIRCUIT REQUIREMENTS</b> .....	4
110V OPERATION .....	4
GROUNDING .....	4-5
<b>3. GENERAL INFORMATION</b> .....	6
UNPACKING .....	7
PIECE INVENTORY .....	7
CLEAN UP.....	8
SITE CONSIDERATIONS .....	8
<b>4. ASSEMBLY</b> .....	9
BEGINNING ASSEMBLY .....	9
BASE AND COLUMN .....	9
TABLE .....	10
HEAD STOCK .....	10
DRILL CHUCK.....	11
HANDLES .....	11
<b>5. ADJUSTMENTS</b> .....	12
SPEED CHANGE .....	12
SPINDLE ADJUSTMENTS .....	13
TABLE ADJUSTMENTS .....	13
<b>6. OPERATIONS</b> .....	14
TEST RUN.....	14
DRILL CHANGES .....	14
DRILLING METAL .....	15
DRILLING WOOD .....	15
<b>7. MAINTENANCE</b> .....	16
GENERAL .....	16
TABLES .....	16
LUBRICATION.....	16
<b>8. CLOSURE</b> .....	17
PARTS BREAKDOWN AND PARTS LISTS.....	18-19
MACHINE DATA .....	20
WARRANTY AND RETURNS .....	21
WARRANTY CARD .....	23

# SECTION 1: SAFETY

---

## WARNING: For Your Own Safety Read Instruction Manual Before Operating Drill Press

- a) Always wear eye protection.
- b) Always keep belt guards in place and in proper operating condition.
- c) While operating this machine, do not wear jewelry, loose clothing necklaces or neckties. Remember to roll up long sleeves.
- d) Never leave the chuck key in the drill chuck for any reason.
- e) Secure the workpiece adequately at all times during operation; Clamps or a vise should be used.

## Safety Instructions For Power Tools

These safety rules cannot cover every situation in a work shop. Consider your conditions when setting up or operating your drill press.

1. **KEEP GUARDS IN PLACE** and in working order.
2. **REMOVE ADJUSTING KEYS AND WRENCHES.** Form habit of checking to see that keys and adjusting wrenches are removed from tool before turning on.
3. **KEEP WORK AREA CLEAN.** Cluttered areas and benches invite accidents.
4. **DON'T USE IN DANGEROUS ENVIRONMENT.** Don't use power tools in damp or wet locations, or expose them to rain. Keep work area well lighted.
5. **KEEP CHILDREN AND VISITORS AWAY.** All children and visitors should be kept a safe distance from work area.
6. **MAKE WORK SHOP CHILD PROOF** with padlocks, master switches, or by removing starter keys.
7. **DON'T FORCE TOOL.** It will do the job better and safer at the rate for which it was designed.
8. **USE RIGHT TOOL.** Don't force tool or attachment to do a job for which it was not designed.
9. **USE PROPER EXTENSION CORD.** Make sure your extension cord is in good condition. When using an extension cord, be sure it is rated Hard Service (grade S) or better. Conductor size must be 16 A.W.G. for cords up to 100 feet in length. An undersized cord will cause a drop in line voltage resulting in loss of power and overheating. Your extension cord must also contain a ground wire and plug pin. Always repair or replace extension cords if they become damaged. Minimum Gage for extension cord:

16 A.W.G.	50ft
16 A.W.G.	100ft
14 A.W.G.	200ft
12 A.W.G.	300ft

10. **WEAR PROPER APPAREL** Do not wear loose clothing, gloves, neckties, rings, bracelets, or other jewelry which may get caught in moving parts. Non-slip footwear is recommended. Wear protective hair covering to contain long hair.
11. **ALWAYS USE SAFETY GLASSES.** Also use face or dust mask if cutting operation is dusty. Everyday eyeglasses only have impact resistant lenses, they are NOT safety glasses.
12. **SECURE WORK.** Use clamps or a vise to hold work when practical. It's safer than using your hand and frees both hands to operate tool.
13. **DON'T OVERREACH.** Keep proper footing and balance at all times.
14. **MAINTAIN TOOLS WITH CARE.** Keep tools sharp and clean for best and safest performance. Follow instructions for lubricating and changing accessories.
15. **DISCONNECT TOOLS** before servicing and changing accessories, such as blades, bits, cutters, and the like.
16. **REDUCE THE RISK OF UNINTENTIONAL STARTING.** Make sure switch is in off position before plugging in.
17. **USE RECOMMENDED ACCESSORIES.** Consult the owner's manual for recommended accessories. The use of improper accessories may cause risk of injury.
18. **CHECK DAMAGED PARTS.** Before further use of the tool, a guard or other part that is damaged should be carefully checked to determine that it will operate properly and perform its intended function-check for alignment of moving parts, binding of moving parts, breakage of parts, mounting, and any other conditions that may affect its operation. A guard or other part that is damaged should be properly repaired or replaced.
19. **DIRECTION OF FEED.** Feed work into a blade or cutter against the direction of rotation of the blade or cutter only.
20. **NEVER LEAVE TOOL RUNNING UNATTENDED. TURN POWER OFF.** Don't leave tool until it comes to a complete stop.

## Additional Safety Instructions For Mini Drill Press

1. Always operate your drill press at speeds that are appropriate for the drill bit size and the material that your are drilling.
2. Feed the drill bit evenly into the workpiece. Back the bit out of deep holes and clear the chips with a brush after you have turned the machine off.
3. Make sure the drill bit you are using is tightened properly. Use only round or triangular shank drill bits.
4. Never do maintenance or change speeds with this machine plugged in.
5. Never use tools that are in poor condition. Cutting tools that are dull or damaged are difficult to control and may cause serious injury.
6. Never drill sheet metal unless it is clamped securely to the table.
7. Work should be positioned in such a way as to avoid drilling into the table.
8. A face guard used with safety glasses are recommended.
9. Habits – good and bad – are hard to break. Develop good habits in your shop and safety will become second-nature to you.

# SECTION 2: CIRCUIT REQUIREMENTS

---

---

## 110V Operation

---

---

The motor supplied with the G4014 is wired for 110 volt operation. Under normal use, the motor draws approximately 1.25 amps. We recommend a 10 amp circuit breaker. This should be satisfactory for normal use, while providing enough protection against motor damage caused by power surges. Grizzly recommends that the circuit you use should be dedicated, (i.e., the G4014 should provide the only draw from that circuit). If frequent circuit failures occur when using the drill press, contact our service department or your local electrical contractor.

**CAUTION:** Be sure that your particular electrical configuration complies with local and state codes. The best way to ensure compliance is to check with your local municipality or licensed electrician.



## Grounding

---

---

**CAUTION:** THIS TOOL MUST BE GROUNDED WHILE IN USE TO PROTECT THE OPERATOR FROM ELECTRIC SHOCK.

In the event of a malfunction or breakdown, grounding provides a path of least resistance for electric current to reduce the risk of electric shock. This tool is equipped with an electric cord having an equipment-grounding conductor and a grounding plug. The plug must be plugged into a matching outlet that is properly installed and grounded in accordance with all local codes and ordinances.

Improper connections of the electrical-grounding conductor can result in risk of electric shock. The conductor with green or green and yellow striped insulation is the electrical-grounding conductor. If repair or replacement of the electric cord or plug is necessary, do not connect the equipment grounding conductor to a live terminal.



Under no circumstances should the grounding pin from any three-pronged plug be removed. If it will not fit the outlet, have the proper outlet installed by a qualified electrician.

Check with a qualified electrician or one of our service personnel if the grounding instructions are not completely understood, or if in doubt as to whether the tool is properly grounded. Use only 3-wire extension cords that have 3-prong grounding type plugs and 3-hole receptacles that accept the tool's plug. **Figure 1.**

Repair or replace damaged or worn cord immediately.

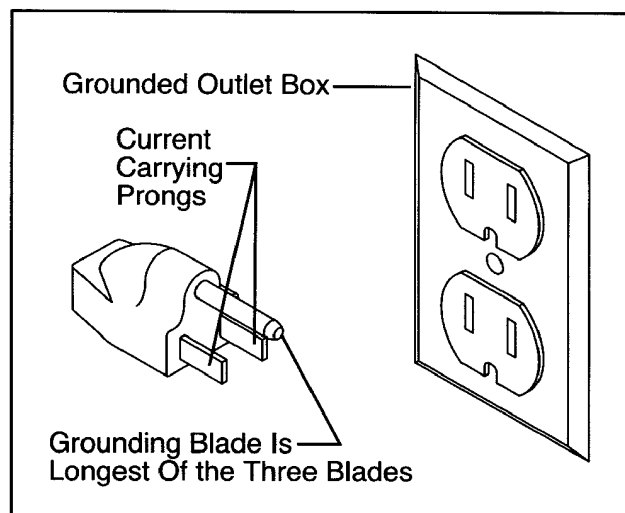

**Figure 1.**



# SECTION 3: GENERAL INFORMATION

---

Grizzly Industrial, Inc. is proud to offer the Model G4014 Mini Drill Press. The G4014 is part of Grizzly's growing family of fine woodworking and metalworking machinery. When used according to the guidelines stated in this manual, you can expect years of trouble-free, enjoyable operation.

The Model G4014 is intended for home use. The G4014 features cast iron construction for rigidity and strength. The slotted base and table make clamping easy. The five belt speeds give this machine a measure of versatility and the ½" drill chuck enhances this machine's capacity.

All running parts utilize shielded ball bearings, which require no lubrication for the life of the bearings.

We are also pleased to provide this manual with the Model G4014. It was written to guide you through assembly, review safety considerations, and cover general operating procedures. It represents our latest effort to produce the best documentation possible. If you have any criticisms that you feel we should address in our next printing, please write to us at the Bellingham, WA address at the end of this section.

Most important, we stand behind our machines. We have an excellent service department at your disposal should the need arise. If you have any service questions or parts requests, please call or write to us at the location listed below.

Grizzly Industrial, Inc.  
2406 Reach Road  
Williamsport, PA 17701  
Phone:(717) 326-3806  
Fax:(800) 438-5901  
E-Mail: grizzlytec@aol.com  
Web Site: www.grizzlyindustrial.com

To comment on this manual write to:

Grizzly Industrial, Inc.  
% Technical Documentation  
P.O. Box 2069  
Bellingham, WA 98227

To operate this, or any other power tool safely and efficiently, it is essential to become as familiar with it as possible. The time you invest before you begin to use your Model G4014 will be time well spent. **DO NOT** operate this machine until you are completely familiar with the contents of this manual.

# Unpacking

---

---

The Model G4014 Mini Drill Press is shipped from the manufacturer in a carefully packed carton. If you discover the machine is damaged after you've signed for delivery, *please call Customer Service immediately for advice.*

Save the containers and all packing materials for possible inspection by the carrier or its agent. *Otherwise filing a freight claim can be difficult.*

**Caution:** The G4014 is a heavy machine, 47 lbs. shipping weight. **DO NOT** over-exert yourself while unpacking or moving your machine – get assistance. In the event that your Drill Press must be moved up or down a flight of stairs, be sure that the stairs are capable of supporting the combined weight of people and the machine.

When you are completely satisfied with the condition of your shipment, you should inventory its parts.



# Piece Inventory

---

---

After all the parts have been removed from the carton, you should have:

- Work Table
- Column
- Base
- Head Stock Assembly
- Drill Chuck
- Key
- Hardware

Hardware	Qty
Hex Bolts M8-1.25 X 18	3
Column Lock Handle	1
Allen Wrench 3mm, 4mm	1
V-Belt	1
Handle Bars	3
Knobs	3

In the event that any non-proprietary parts are missing (e.g. a nut or a washer), we would be glad to replace them, or, for the sake of expediency, replacements can be obtained at your local hardware store.



# Clean up

---

---

The table and other unpainted parts of the Model G4014 are coated with a waxy oil that protects them from corrosion during shipment. Remove the protective coating with mineral spirits and paper towels. Do not use gasoline or other petroleum based solvents because of their extremely low flash points. Do not use chlorine-based solvents – if you happen to splash some onto a painted surface, you'll ruin the finish.

## **WARNING!**

***Follow the safety rules listed below when working with solvents:***

1. Read and follow all directions and warnings on the solvent label.
2. Work only in a well ventilated area.
3. Do not work near any type of open flame (e.g., pilot lights, kerosene heaters, and so on).
4. **DO NOT** smoke while working with flammable material.
5. Paper towels from the cleaning process are extremely combustible. Dispose of waste towels so they do not create a fire hazard.



# Site Considerations

---

---

1. **Work Table:** Your G4014 represents a relatively large weight load on a small footprint. Select a Work Table that will support the weight of the G4014 and the material you intend to drill. Make sure the base of the drill press is fastened securely to the work bench with clamps or bolts.
2. **Working Clearances:** Consider existing and anticipated needs, size of material to be processed through each machine, and space for auxiliary stands, work tables or other machinery when establishing a location for your drill press.
3. **Lighting and Outlets:** Lighting should be bright enough to eliminate shadow and prevent eye strain. Electrical circuits should be dedicated or large enough to handle amperage requirements. Outlets should be located near each machine so power or extension cords are clear of high-traffic areas. Observe local electrical codes for proper installation of new lighting, outlets, or circuits.



# SECTION 4: ASSEMBLY

---

---

## Beginning Assembly

---

---

Most of your G4014 Mini Drill Press has been assembled at the factory, but some parts must be assembled or installed after delivery. We have organized the assembly process into steps. Please follow along in the order presented here.

**Note:** All die-cut metal parts have a sharp edge (called “flashing”) on them after they are formed. This is removed at the factory. Sometimes, though, a bit of flashing might escape inspection. Please examine the edges of all metal parts before handling them.

**TOOLS REQUIRED:** You will need a 10mm, 12mm and 14mm open end wrench, a flat tipped screwdriver and a 3mm and 4mm Allen wrench (supplied).



## Base/Column

---

---

1. Place the base on a suitable bench. Make sure the surface is flat and stable. Secure the base to the table top with clamps or with two lag or through bolts.
2. Place the column on the base and line up the 3 holes. Secure tightly with the three M8-1.25 x 18mm Hex Head Bolts provided. **Figure 2.**

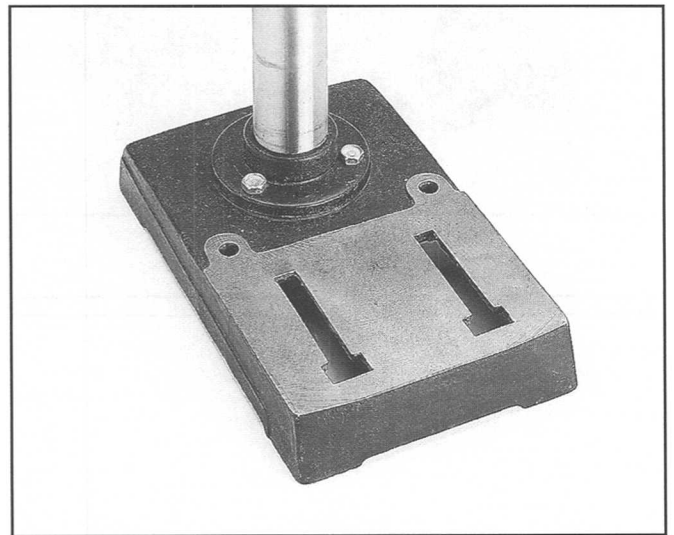
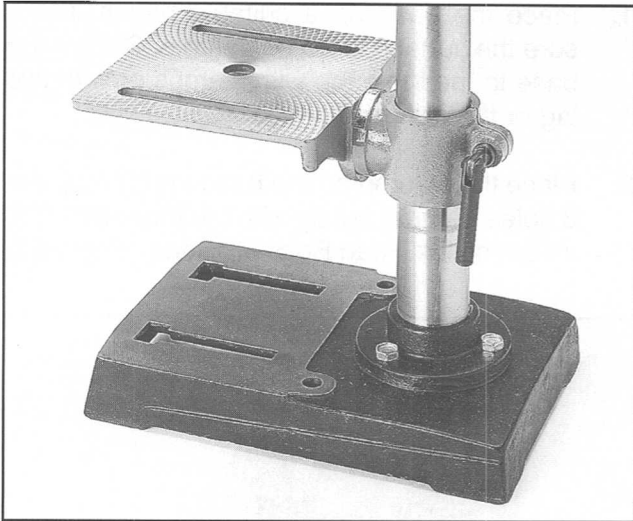

**Figure 2.**



## Table

Slide the table bracket onto the column and lock it down with lock handle positioned near the center of the column. **Figure 3.**

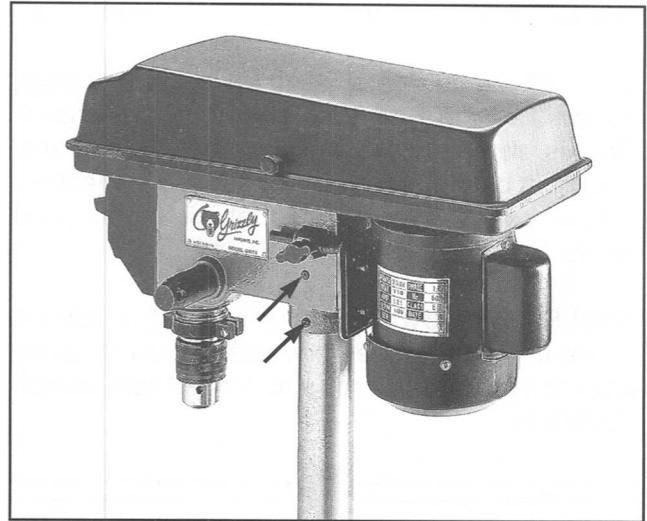

**Figure 3.**



## Head Stock

1. Place the head assembly onto the top of the column and lower it until it sits on the stop-pin. **CAUTION:** The head assembly is heavy; seek assistance for lifting and placement.
2. Secure the head to the column by tightening the two slotted head screws. **Figure 4.**



**Figure 4.**



# Drill Chuck

The drill press chuck must be mounted to the drill press spindle. The bottom of the spindle and the back of the chuck are Jacobs Taper #33. The drill press chuck and spindle are held together by friction fit. To mount the drill chuck on the spindle:

1. Thoroughly clean all of the shipping oil or grease from the inside of the drill press chuck and the spindle. Use mineral spirits and a clean rag.
2. Turn the body of the drill press chuck with the chuck key supplied until the jaws are all the way up inside its body.
3. Slide the chuck onto the spindle and tap it on the bottom with a soft hammer or a block of wood. **Figure 5.** The drill chuck should now be quite snug on the spindle. If not, repeat 1 and 2, making sure all oil or grease is removed.

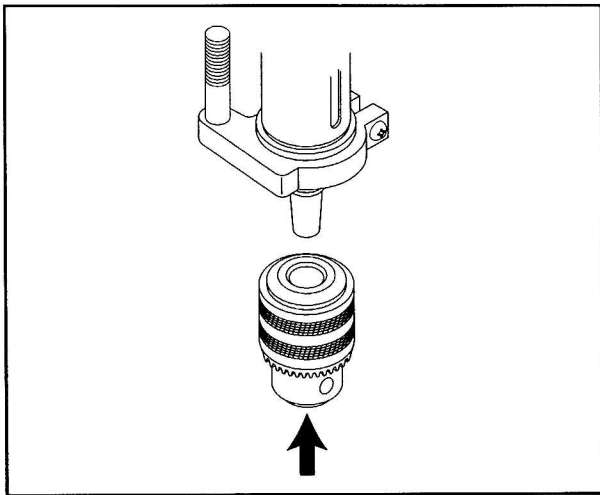

**Figure 5.**



# Handles

Screw the handles into the elevation axle.

**Figure 6.**

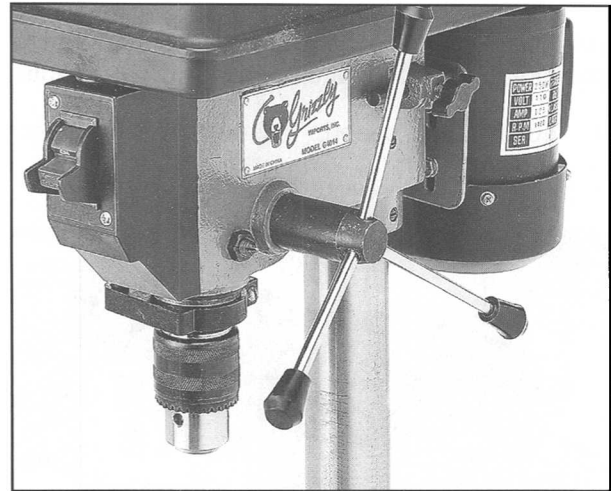

**Figure 6.**



# SECTION 5: ADJUSTMENTS

## Speed Change

Remember to disconnect the drill press from the power source before attempting any adjustments.

1. To change speed, loosen the lock knob. **Figure 7.**

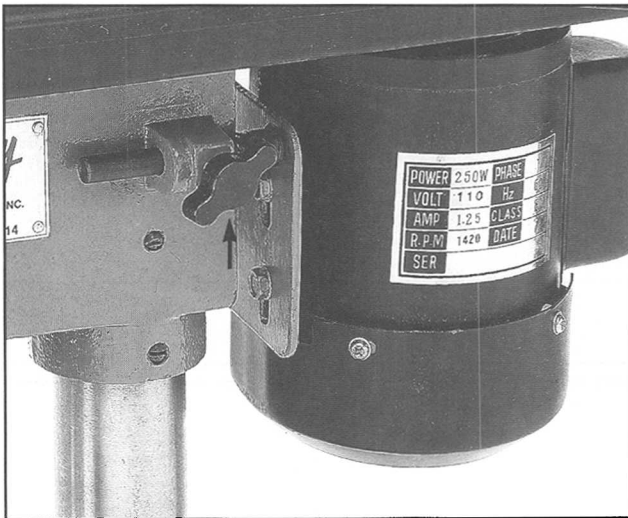

**Figure 7.**

2. The motor is mounted on a hinge. Pull the motor in closer to the head stock and roll the belt off of the pulleys.
3. Select the proper speed by referring to the chart inside the pulley cover. Place the belt onto the corresponding position for the selected speed.
4. Push the motor away from the head stock, push the motor support rod into the motor and tighten the lock knob.
5. Close the cover. **CAUTION:** Never run the drill press with the cover open.

**NOTE:** The speed chart under the pulley cover reflects two different power cycles for the motor. Use the 60 cycles per second spindle R.P.M. reference in the U.S.A.





# Spindle Adjustments

---

1. To stop the vertical travel of the drill bit at a desired depth, loosen the jam nut on the depth stop rod. **Figure 8.**
2. Roll the spindle down while watching the indicator arrow on the scale and stop at the desired depth.
3. Turn the lower nut while maintaining this depth until the nut comes into contact with the stop flange.
4. Allow the spindle to return to its original position and tighten the jam nut against the stop nut while making sure the stop nut does not move.

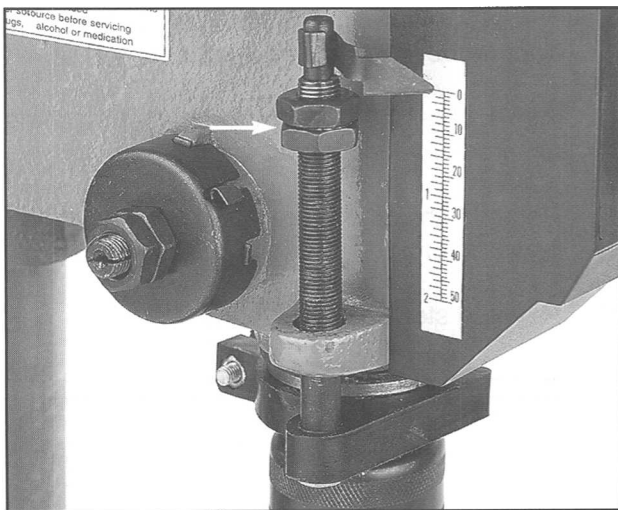

**Figure 8.**



# Table Adjustments

---

1. To adjust the table up or down, hold onto the table with one hand and with the other, loosen the column lock handle and lift or lower to the desired height. Secure the table with the lock handle. **Figure 9.**
2. To swing the table, support the table and loosen the lock handle as above. Swing the work table to the desired position and secure the table with the lock handle.
3. For workpieces that are extra long, swing the work table 180° and use the base as your work table.

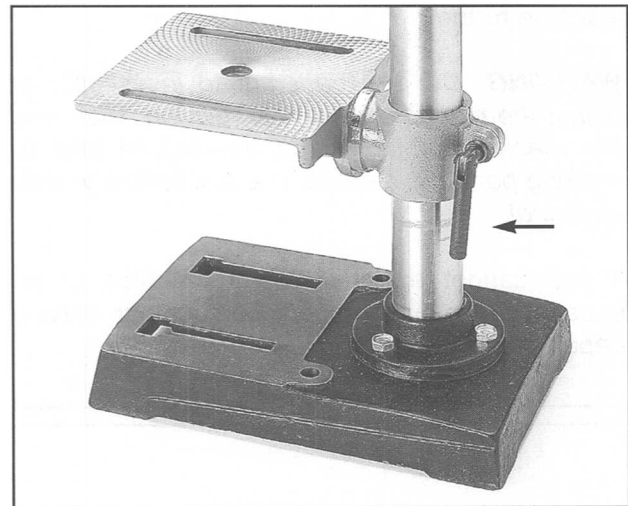

**Figure 9.**



# SECTION 6: OPERATIONS

---

---

## Test Run

---

---

Once assembly is complete and adjustments are done to your satisfaction, you are ready to test run the machine.

Make sure the starting switch is off and plug in machine. Press the START button. Make sure that your finger is poised on the STOP button, just in case there's a problem. The drill press should run smoothly, with little or no vibration or rubbing noises. Strange or unnatural noises should be investigated and corrected before operating the machine further.

**WARNING:** *DO NOT attempt to investigate or adjust the machine while it is running. Wait until the machine is turned off, unplugged and all working parts have come to a rest before you do anything!*

If you cannot easily locate the source of an unusual noise or vibration, contact our service department for help.

---

---



## Drill Changes

---

---

To insert a bit, care must be taken to secure the bit firmly in place. When changing bits, proceed as follows:

1. Disconnect the machine from the power source.
  2. Open the chuck wide enough to accept a new bit.
  3. Install the bit so the chuck jaws will grab the major portion of the bit shank. Do not allow the chuck to grab the fluted body of the drill bit. Make sure small drill bits do not get trapped between two of the jaws.
  4. Tighten the chuck with the chuck key using all three key locations.
  5. Remove the chuck key and reconnect the power source.
  6. Reverse steps to remove the drill bit.
- 
- 



# Drilling Wood

Twist bits, which are intended for metal, may also be used for boring holes in wood. Machine spur bits are generally preferred, they cut a square bottomed hole and are designed for removal of wood chips. Do not use hand bits which have a screw tip; at drill press speeds they turn into the wood too fast and tend to lift the workpiece off the table and spin it.

For through boring, line up the hole in the work table with the bit to avoid damaging its tip. Scribe a vertical line on the column and matching line on the table bracket so the table can be repositioned in true alignment at any height.

When using your drill press for operations such as shaping, sanding or hole sawing, use jigs, fixtures or hold downs that are appropriate.

The chuck will accept any cutting tool with up to a 1/2" shank. Do not attempt to open the chuck wider by forcing it.



# Drilling Metal

When drilling metal, use clamps to hold the workpiece securely in place. The workpiece should never be held in place by bare hands. The cutting edge can catch in the material at any time, resulting in serious injury. Any movement of the workpiece during the drilling operation may result in a rough or misplaced hole and increases the chance of breaking the bit.

For flat work, lay the workpiece on a wooden base and clamp it firmly to the table. Use a V-block and clamp for round stock. A drill press vise with prismatic jaws can also be used to hold flat or round material.



## Recommended Drill Speed RPM

The best speed to use in any drill press operation is determined by; material, size of the drill bit, type of drill bit or cutter and quality of the cut desired. The smaller the drill bit, the greater the speed. In soft materials, the speed should be higher than for hard materials.

<u>Drill Diameter</u>	<u>Cast Iron</u>	<u>Steel</u>	<u>Aluminum</u>	<u>Wood</u>
1/8"	1720	3100	3100	3100
3/16"	1100	1720	2340	3100
1/4"	1100	1100	1720	2340
5/16"	620	1100	1720	2340
3/8"	620	1100	1100	1720
7/16"	—	620	1100	1100
1/2"	—	620	620	1100
9/16"	—	620	620	1100
5/8"	—	—	—	620
3/4"	—	—	—	620
7/8"	—	—	—	620
1"	—	—	—	620

# SECTION 7: MAINTENANCE

---

---

## General

---

---

Regular periodic maintenance on your Model G4014 Mini Drill Press will ensure its optimum performance. Make a habit of inspecting your drill press each time you use it. Check for the following conditions and repair or replace when necessary.

1. Loose mounting bolts.
2. Worn switch.
3. Worn or damaged cords and plugs.
4. Damaged V-belt.
5. Any other condition that could hamper the safe operation of this machine.

**Caution:** Always perform any maintenance with the power off and the machine unplugged.



## Tables

---

---

Tables can be kept rust-free with regular applications of products like Boeshield® T-9. For long term storage you may want to consider products like Kleen Bore's *Rust Guardit*™.



## Lubrication

---

---

Since all bearings are shielded and permanently lubricated, simply leave them alone until they need to be replaced. Do not lubricate them.

For other items on this machine, such as the quill, table and column, an occasional shot of light machine oil is all that is necessary. Before applying lubricant, clean off sawdust and metal chips.

Your goal is to achieve adequate lubrication. Too much lubrication will attract dirt and sawdust. Various parts of your machine could lose their freedom of movement as a result.



# SECTION 8: CLOSURE

---

The following pages contain general machine data, parts diagrams/lists, troubleshooting guide and warranty/return information for your Model G4014 Mini Drill Press.

If you need parts or help in assembling your machine, or if you need operational information, we encourage you to call our Service Department. Our trained service technicians will be glad to help you.

If you have comments dealing specifically with this manual, please write to our Bellingham, Washington location using the address in the General Information. The specifications, drawings, and photographs illustrated in this manual represent the Model G4014 as supplied when the manual was prepared. However, due to Grizzly's policy of continuous improvement, changes may be made at any time with no obligation on the part of Grizzly. Whenever possible, though, we send manual updates to all owners of a particular tool or machine. Should you receive one, add the new information to this manual and keep it for reference.

We have included some important safety measures that are essential to this machine's operation. While most safety measures are generally universal, Grizzly reminds you that each workshop is different and safety rules should be considered *as they apply to your specific situation*.

We recommend you keep a copy of our current catalog for complete information regarding Grizzly's warranty and return policy. If you need additional technical information relating to this machine, or if you need general assistance or replacement parts, please contact the Service Department listed in *Section 3: General Information*.

Additional information sources are necessary to realize the full potential of this machine. Trade journals, woodworking magazines, and your local library are good places to start.

## **WARNING!**

*As with all power tools, there is danger associated with the Model G4014 Mini Drill Press. Use the tool with respect and caution to lessen the possibility of mechanical damage or operator injury. If normal safety precautions are overlooked or ignored, injury to the operator or others in the area is likely.*

The Model G4014 was specifically designed for drilling operations. **DO NOT MODIFY AND/OR USE THIS DRILL PRESS FOR ANY OTHER PURPOSE. Modifications or improper use of this tool will void the warranty.** If you are confused about any aspect of this machine, **DO NOT** use it until you have answered all your questions.

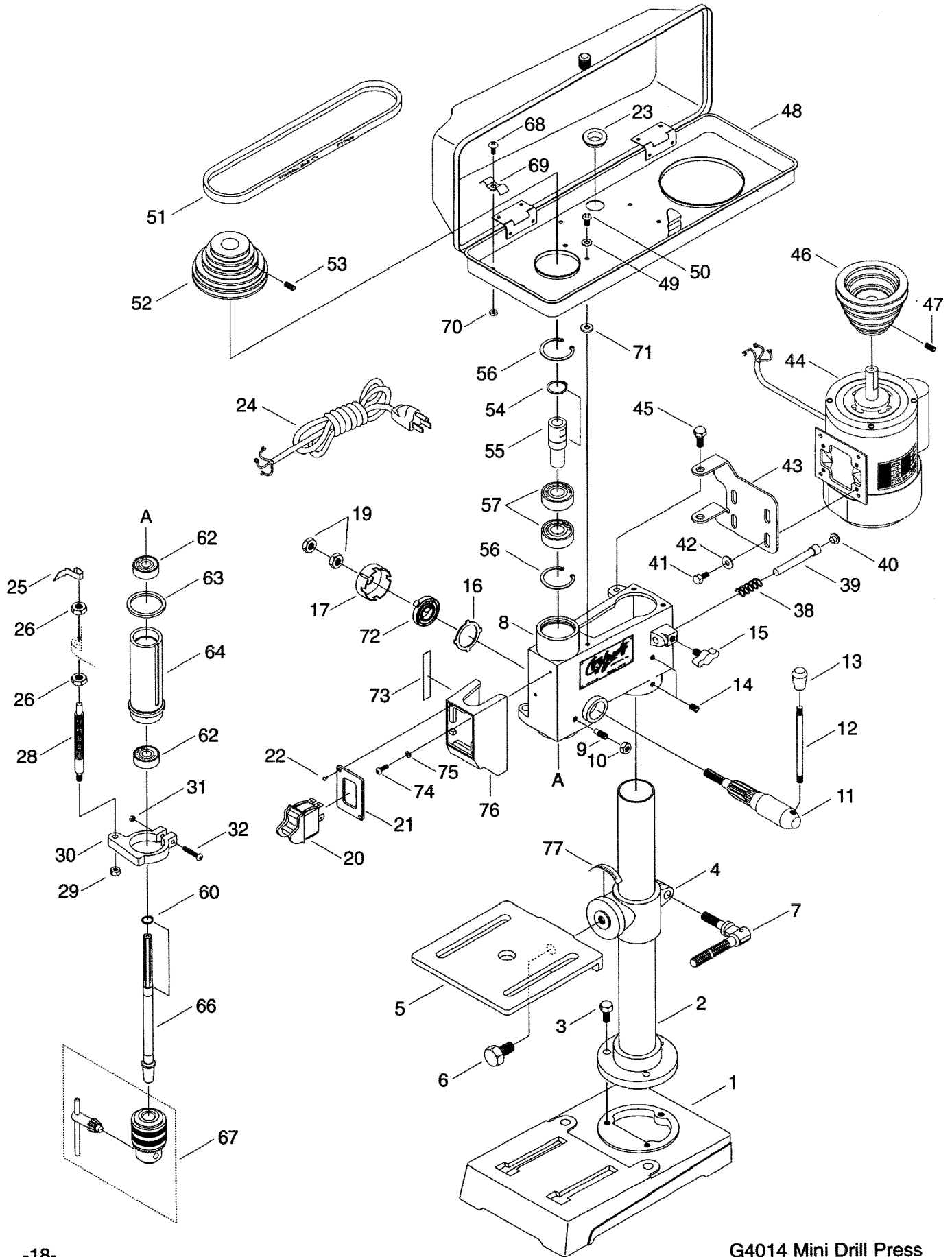

REF	PART #	DESCRIPTION
01	P4014001	BASE
02	P4014002	COLUMN
03	PB09M	HEX BOLT M8-1.25 X 20
04	P4014004	CLAMPING SLEEVE
05	P4014005	TABLE
06	PB25M	HEX BOLT M12-1.75 X 25
07	P4014007	CLAMPING LEVER
08	P4014008	BODY
09	PSS14M	SET SCREW M8-1.25 X 12
10	PN03M	HEX NUT M8-1.25
11	P4014011	FEED SHAFT
12	P4014012	HANDLE BAR
13	P4014013	KNOB
14	PSS20M	SET SCREW M8-1.25 X 8
15	PW07	SHIFTER BAR
16	PB23	SPRING
17	P4014017	SPRING HOUSING
19	P4014019	JAM NUT M10-1.0
20	PSW06	SWITCH
21	P4014021	MOUNT PLATE
22	P4014022	SHEET METAL SCREW
23	P4014023	GROMET
24	P4014078	POWER CORD
25	P4014025	POINTER
26	P4014019	JAM NUT M10-1.0
28	P4014028	LIMIT BOLT
29	PN01M	HEX NUT M6-1.0
30	P4014030	BRACKET
31	PN06M	HEX NUT M5-0.8
32	P4014032	PHLP HD SCR M5-0.8 X 24
38	P4014038	SPRING
39	P4014039	SLIDE BAR
40	P4014040	RUBBER BUMPER

REF	PART #	DESCRIPTION
41	PB02M	HEX BOLT M6-1.0 X 12
42	PW03M	FLAT WASHER M6
43	P4014043	MOTOR PLATE
44	P4014044	MOTOR
45	P4014045	SPECIAL BOLT
46	P4014046	MOTOR PULLEY
47	PSS04M	SET SCREW M6-1.0 X 12
48	P4014048	PULLEY COVER
49	PW03M	FLAT WASHER M6
50	PS14M	PHLP HD SCR M6-1.0 X 12
51	PVM26	V-BELT M-26 3L260
52	P4014052	SPINDLE PULLEY
53	PSS04M	SET SCREW M6-1.0 X 12
54	PR10M	EXT SNAP RING M22
55	P4014056	SPLINED SLEEVE
56	PR24M	INT SNAP RING M42
57	P6203	BALL BEARING 6203
60	PR03M	EXT SNAP RING M12
62	P6201	BALL BEARING 6201
63	P4014063	RUBBER COLLAR
64	P4014064	QUILL
66	P4014066	SPINDLE
67	P4014067	DRILL CHUCK
68	PS09M	PHLP HD SCR M5-0.8 X 10
69	P4014069	CLAMP
70	PN06M	HEX NUT M5-0.8
71	P4014071	RUBBER WASHER
72	P4014072	SPRING
73	P4014073	SCALE
74	PS08M	PHLP HD SCR M5-0.8 X 12
75	PW02M	FLAT WASHER M5
76	P4014076	SWITCH BOX
77	P4014007	DEGREE SCALE

# MACHINE DATA

## GRIZZLY MODEL G4014 DRILL PRESS

Design Type .....Bench Model

### Overall Dimensions:

Table.....6 1/2" X 6 3/8"  
Overall Height .....24"  
Overall Width .....7"  
Overall Depth .....12"  
Shipping Weight ..... 47 lbs.  
Weight in Place ..... 40 lbs.

### Construction:

Table .....Cast Iron  
Column.....Ground Steel Tubing  
Base & Head .....Cast Iron

### Capacities:

Spindle Travel .....2 3/4"  
Max. Distance, Spindle to Base ..... 10"  
Max. Distance, Spindle to Table .....7"  
Spindle Taper .....J.T. #33  
Swing .....8"  
Chuck Size .....1/2"  
Speeds .....5  
Range of Speeds .....620-3100 RPM  
Table Tilt .....0-90°

### Motor:

Type .....TEFC Capacitor Start Induction  
Horsepower .....1/3 HP  
Phase / Cycle .....Single Phase / 60 Hz  
Voltage.....110  
Amps ( @ 110/220) .....1.25  
RPM .....1420  
Power Transfer .....Belt Drive  
Bearings .....Shielded & Permanently Lubricated Ball

### Features:

Table.....Positive Locks

*Specifications, while accurate, are subject to change without notice.*



# WARRANTY AND RETURNS

---

Grizzly Industrial, Inc. warrants every product it sells for a period of **1 year** to the original purchaser from the date of purchase. This warranty does not apply to defects due directly or indirectly to misuse, abuse, negligence, accidents, repairs or alterations or lack of maintenance. This is Grizzly's sole written warranty and any and all warranties that may be implied by law, including any merchantability or fitness, for any particular purpose, are hereby limited to the duration of this written warranty. We do not warrant or represent that the merchandise complies with the provisions of any law or acts unless the manufacturer so warrants. In no event shall Grizzly's liability under this warranty exceed the purchase price paid for the product and any legal actions brought against Grizzly shall be tried in the State of Washington, County of Whatcom.

We shall in no event be liable for death, injuries to persons or property or for incidental, contingent, special, or consequential damages arising from the use of our products.

To take advantage of this warranty, contact us by mail or phone and give us all the details. We will then issue you a "Return Number", which must be clearly posted on the outside as well as the inside of the carton. We will not accept any item back without this number. Proof of purchase must accompany the merchandise.

The manufacturers reserve the right to change specifications at any time because they constantly strive to achieve better quality equipment. We make every effort to ensure that our products meet high quality and durability standards and we hope you never need to use this warranty.

Please feel free to write or call us if you have any questions about the machine or the manual.

Thank you again for your business and continued support. We hope to serve you again soon.

## Free Manuals Download Website

<http://myh66.com>

<http://usermanuals.us>

<http://www.somanuals.com>

<http://www.4manuals.cc>

<http://www.manual-lib.com>

<http://www.404manual.com>

<http://www.luxmanual.com>

<http://aubethermostatmanual.com>

Golf course search by state

<http://golfingnear.com>

Email search by domain

<http://emailbydomain.com>

Auto manuals search

<http://auto.somanuals.com>

TV manuals search

<http://tv.somanuals.com>