

Grizzly *Industrial, Inc.*®

MODEL G9017/G9018 HYDRAULIC TUBE BENDER INSTRUCTION SHEET



COPYRIGHT © OCTOBER, 2005 BY GRIZZLY INDUSTRIAL, INC.
**WARNING: NO PORTION OF THIS MANUAL MAY BE REPRODUCED IN ANY SHAPE
OR FORM WITHOUT THE WRITTEN APPROVAL OF GRIZZLY INDUSTRIAL, INC.**
#BL7554 PRINTED IN CHINA

Introduction

The Model G9017/G9018 (**Figure 1**) is designed for bending thick walled pipes (schedule 40 and 80) and has six different bending dies ranging in size from 1/2" to 2" for the G9017 (see **Figure 2**) and from 1/2" to 3" for the G9018. The Model G9017/G9018 is not designed for bending thin walled pipes or exhaust pipe.

We stand behind our machines. If you have any service questions or parts requests, please contact us.

Grizzly Industrial, Inc.
 1203 Lycoming Mall Circle
 Muncy, PA 17756
 Phone: (570) 546-9663
 Fax: (800) 438-5901
 E-Mail: techsupport@grizzly.com
 Web Site: <http://www.grizzly.com>

Technical Data

Maximum Working Pressure: 6259 PSI
 Maximum Load..... 24,000 Lbs.
 Maximum Travel..... 9 1/2"
 Pipe Size Capacity (G9017) 1/2"-2"
 (G9018) 1/2"-3"
 Maximum Pipe Wall Thickness 0.179"
 Hydraulic Oil Reservoir Capacity 2.5 Pints
 Type of Hydraulic Oil..... H32
 Weight (G9017), 90 Lbs.
 (G9018), 150 Lbs.

Size	Schedule 40	Schedule 80
1/2"	YES	YES
3/4"	YES	YES
1"	YES	YES
1 1/4"	YES	NO
1 1/2"	YES	NO
2"	YES	NO
2 1/2"	YES	NO
3"	YES	NO

Inventory (Figures 1 & 2)

- A. Bender..... 1
- B. Dies, (G9017) 1/2", 3/4", 1", 1 1/4", 1 1/2", 2")..... 6
- C. Dies, (G9018) 1/2", 3/4", 1", 1 1/4", 1 1/2", 2", 2 1/2", 3")..... 8
- D. Pump Handle Bar..... 1

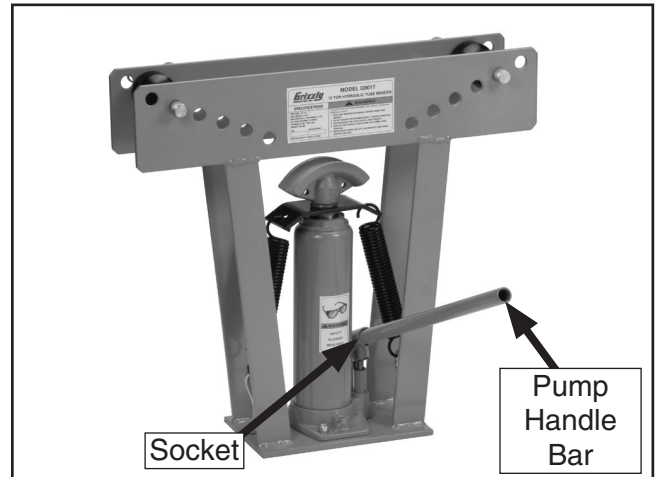

Figure 1. Model G9017.

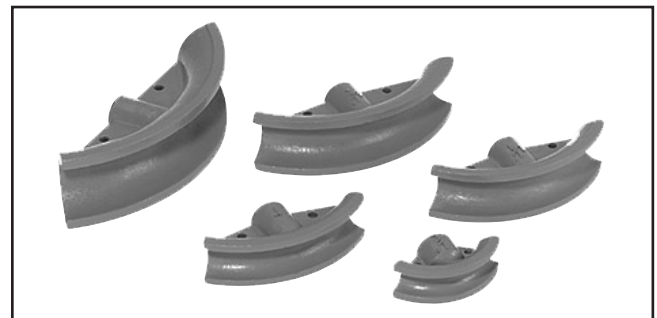



Figure 2. Model G9017 bending dies.



⚠ WARNING

The Model G9017/G9018 is a heavy machine (93/152 lbs. shipping weight). **DO NOT** over-exert yourself while unpacking or moving your machine—get assistance.

OPERATION

To bend a pipe:

1. Insert the pump handle bar into the socket on the tube bender shown in **Figure 1**.
2. Choose the proper size bending die and slip it on the end of the ram as shown in **Figure 3**.

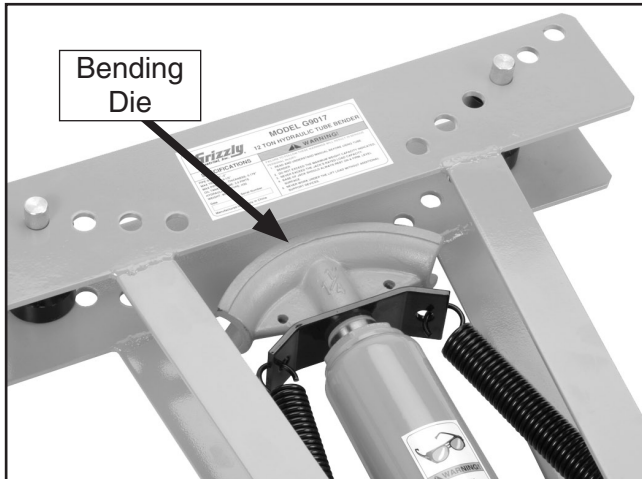

Figure 3. Die installed on bottle jack ram.

3. Choose an angle to bend your pipe. To make a 35-45° bend, place the rollers between the far outside holes on the frame. To make a 90° bend, place the rollers between the holes closest to the ram. Placing the rollers further inside the frame increases the bending angle.
4. To move the rollers, remove the hitch pins and roller shafts (**Figure 4**), and place the rollers between corresponding holes on each side of the frame.

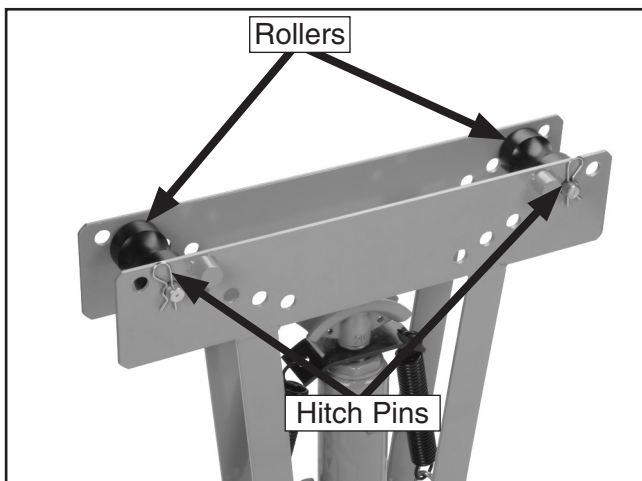

Figure 4. Hitch pin and roller shaft.

5. Reinstall the roller shafts and hitch pins.
6. Place the pipe over the bending die.

Note: To account for pipe shortening during the bend, make sure the pipe extends beyond the rollers (**Figure 5**) and, for short pipe, set the rollers closer together, as shown in **Figure 6**.

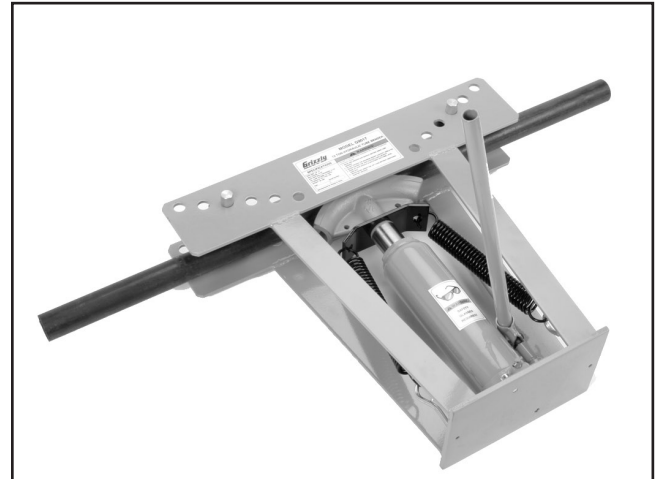

Figure 5. Pipe installed beyond rollers to account for pipe shortening during the bend.



Figure 6. Rollers set close together for bending short pipes.

WARNING

Wear ANSI approved safety glasses at all times.

⚠ CAUTION

Never use a cheater pipe extension on the hydraulic pump handle. Failure to comply may result in personal injury.

7. Make sure the release valve is closed, then use the pump handle bar (**Figure 7**) to advance the die and bend the pipe.

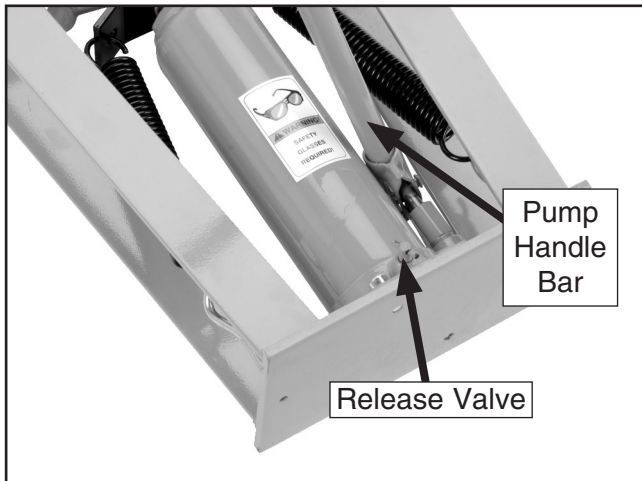

Figure 7. Operating pump and release valve.

8. When you are finished with your bend, release the pressure by opening the release valve and the ram will automatically retreat.

Operation tips and tricks:

- If the ram reaches the end of its stroke but still has not completed a desired bend, release pressure just enough to remove the pipe. Set the rollers either one or two holes farther in to finish the bend.
- We recommend making templates of accurate 45° and 90° angles. Compare these templates to an almost finished pipe so you do not over- or under-bend the pipe. Using templates will speed up your work.
- If you pass the 45° angle mistakenly, you can sometimes reverse the pipe and slightly press it enough to reach the required 45°.
- Bending any angle may thin and stress the walls and narrow the center of the pipe. If you need to make bends more than 100°, we recommend heating the pipe during bending. Generally, heat weakens metal, but it will allow it to bend more freely.

- Pipes bent past 90° will flow into the bending die, making the pipe hard to remove after bending. Greasing the inside of the die will make this removal easier, or switching to a larger die for bending the last few degrees will eliminate this difficulty.

MAINTENANCE

- The Model G9017 and G9018 are basically maintenance free. However, the oil level should be kept constant at about 2.5 pints of quality hydraulic oil.
- Too much oil will force the surplus oil to leak from the bottle jack fill plug (**Figure 8**), causing a mess.
- Not enough oil will cause loss of power.

To add oil:

1. Set the tube bender upright, retract the piston rod fully and remove the fill plug (**Figure 8**).

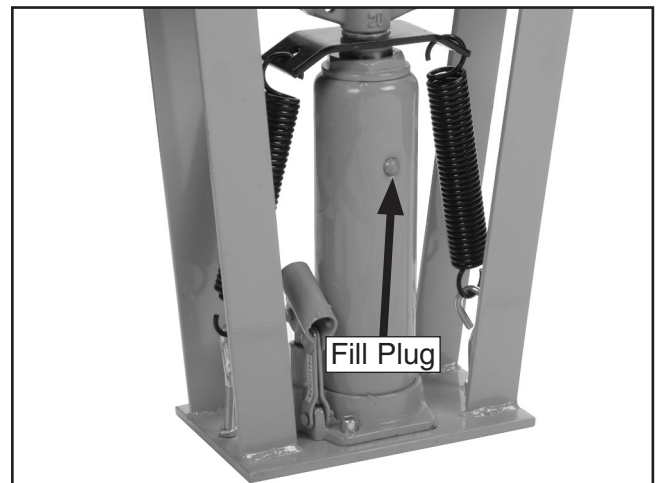
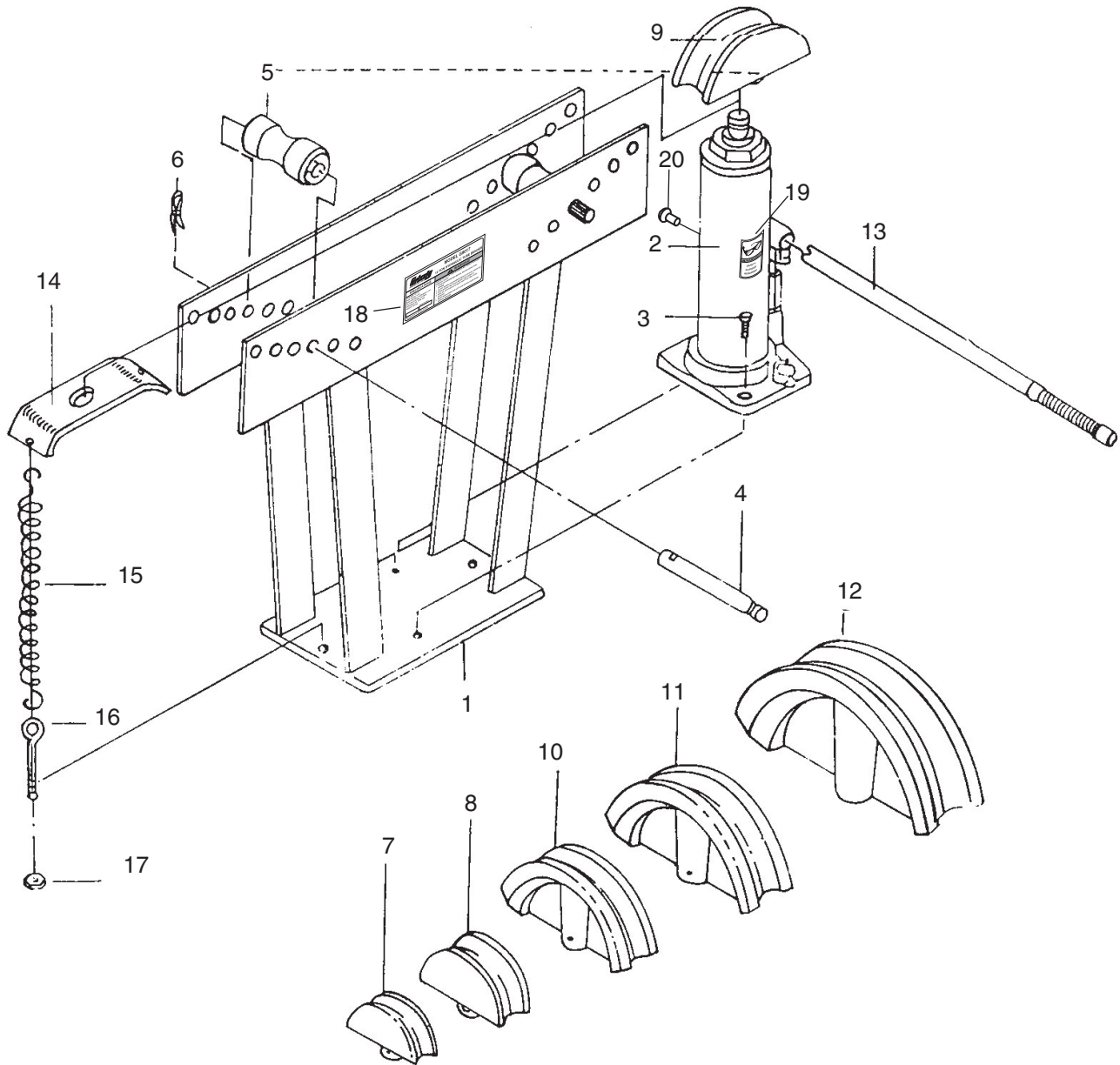

Figure 8. Fill Plug.

2. Fill the bottle jack to the level of the fill plug hole and replace the fill plug.
3. Place the tube bender in its operating position, fully extend the piston rod, then retract the rod to expel air in the bottle jack.
4. Remove the fill plug and repeat **Steps 2 & 3** until all of the air is expelled.

If you need additional help with this procedure, call our Service Department at: (570) 546-9663.

G9017 Parts Breakdown



G9017 Parts List

REF	PART #	DESCRIPTION
1	P9017001	FRAME
2	P9017002	12 TON BOTTLE JACK
3	PSB146M	CAP SCREW M10-1.5 X 15
4	P9017004	ROLLER SHAFT
5	P9017005	ROLLER
6	P9017006	HITCH PIN
7	P9017007	1/2" BENDING DIE
8	P9017008	3/4" BENDING DIE
9	P9017009	1" BENDING DIE
10	P9017010	1-1/4" BENDING DIE

REF	PART #	DESCRIPTION
11	P9017011	1-1/2" BENDING DIE
12	P9017012	2" BENDING DIE
13	P9017013	PUMP HANDLE BAR
14	P9017014	SPRING PLATE
15	P9017015	EXTENS. SPRING 35 X 4.5 X 21.5
16	P9017016	EYE BOLT
17	PN03M	HEX NUT M8-1.25
18	P9017018	MACHINE ID LABEL
19	PLABEL 11	LABEL (SAFETY GLASSES)
20	P9017019	FILL PLUG

G9018 Parts Breakdown

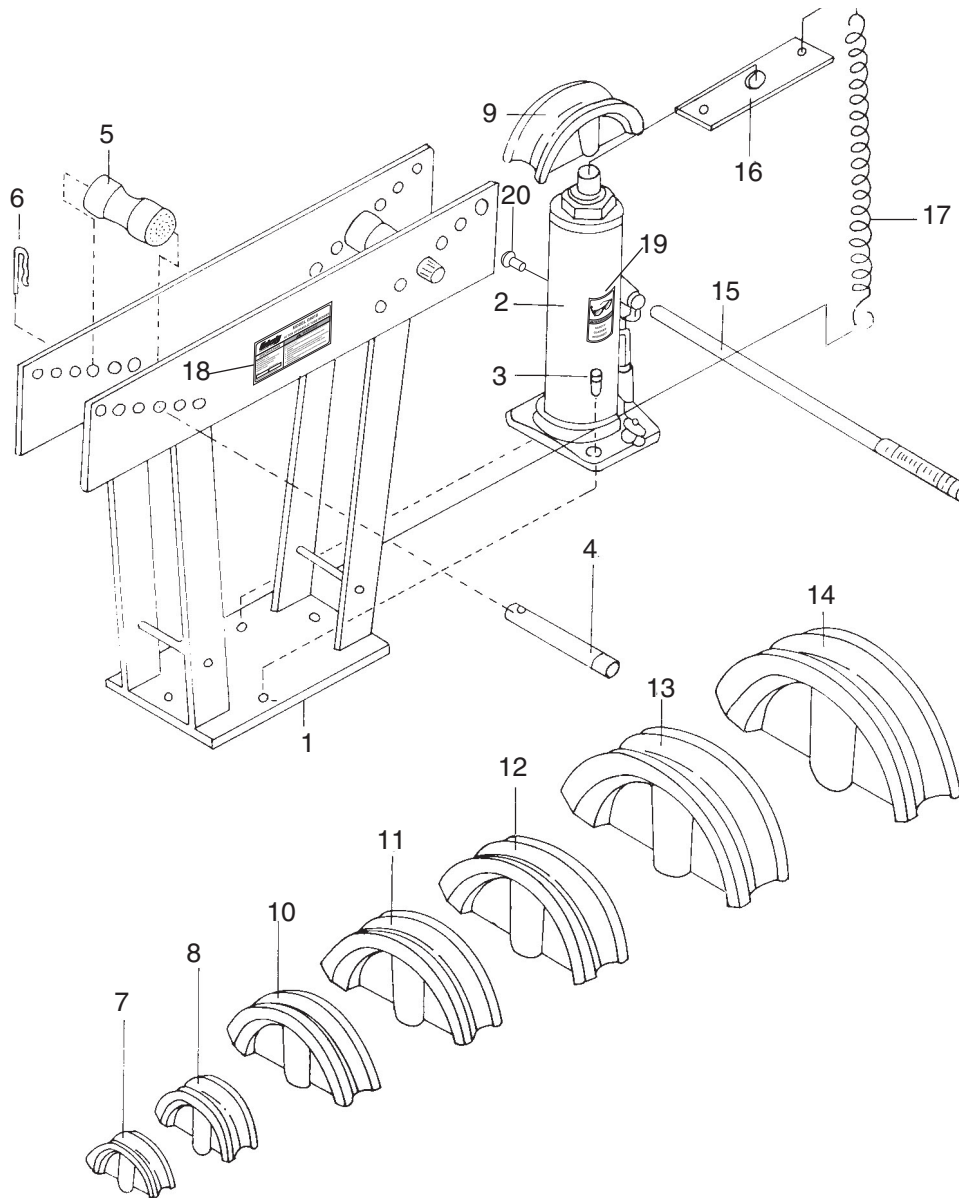

G9018 Parts List

REF	PART #	DESCRIPTION
1	P9018001	FRAME
2	P9018002	16 TON LONG RAM JACK
3	PSB61M	CAP SCREW M10-1.5 X 20
4	P9018004	ROLLER SHAFT
5	P9018005	ROLLER
6	P9018006	HITCH PIN
7	P9018007	1/2" BENDING DIE
8	P9018008	3/4" BENDING DIE
9	P9018009	1" BENDING DIE
10	P9018010	1-1/4" BENDING DIE

REF	PART #	DESCRIPTION
11	P9018011	1-1/2" BENDING DIE
12	P9018012	2" BENDING DIE
13	P9018013	2-1/2" BENDING DIE
14	P9018014	3" BENDING DIE
15	P9018015	PUMP HANDLE BAR
16	P9018016	SPRING PLATE
17	P9018017	EXTENS. SPRING 35 X 1.5 X 21.5
18	P9018018	MACHINE ID LABEL
19	PLABEL 11	LABEL (SAFETY GLASSES)
20	P9018020	FILL PLUG



WARRANTY CARD

Name _____
 Street _____
 City _____ State _____ Zip _____
 Phone # _____ Email _____ Invoice # _____
 Model # _____ Order # _____ Serial # _____

The following information is given on a voluntary basis. It will be used for marketing purposes to help us develop better products and services. **Of course, all information is strictly confidential.**

1. How did you learn about us?

Advertisement Friend Catalog
 Card Deck Website Other:

2. Which of the following magazines do you subscribe to?

<input type="checkbox"/> Cabinet Maker	<input type="checkbox"/> Popular Mechanics	<input type="checkbox"/> Today's Homeowner
<input type="checkbox"/> Family Handyman	<input type="checkbox"/> Popular Science	<input type="checkbox"/> Wood
<input type="checkbox"/> Hand Loader	<input type="checkbox"/> Popular Woodworking	<input type="checkbox"/> Wooden Boat
<input type="checkbox"/> Handy	<input type="checkbox"/> Practical Homeowner	<input type="checkbox"/> Woodshop News
<input type="checkbox"/> Home Shop Machinist	<input type="checkbox"/> Precision Shooter	<input type="checkbox"/> Woodsmith
<input type="checkbox"/> Journal of Light Cont.	<input type="checkbox"/> Projects in Metal	<input type="checkbox"/> Woodwork
<input type="checkbox"/> Live Steam	<input type="checkbox"/> RC Modeler	<input type="checkbox"/> Woodworker West
<input type="checkbox"/> Model Airplane News	<input type="checkbox"/> Rifle	<input type="checkbox"/> Woodworker's Journal
<input type="checkbox"/> Modeltec	<input type="checkbox"/> Shop Notes	<input type="checkbox"/> Other:
<input type="checkbox"/> Old House Journal	<input type="checkbox"/> Shotgun News	

3. What is your annual household income?

\$20,000-\$29,000 \$30,000-\$39,000 \$40,000-\$49,000
 \$50,000-\$59,000 \$60,000-\$69,000 \$70,000+

4. What is your age group?

20-29 30-39 40-49
 50-59 60-69 70+

5. How long have you been a woodworker/metalworker?

0-2 Years 2-8 Years 8-20 Years 20+ Years

6. How many of your machines or tools are Grizzly?

0-2 3-5 6-9 10+

7. Do you think your machine represents a good value?

Yes No

8. Would you recommend Grizzly Industrial to a friend?

Yes No

9. Would you allow us to use your name as a reference for Grizzly customers in your area?

Note: *We never use names more than 3 times.* Yes No

10. Comments: _____

CUT ALONG DOTTED LINE

FOLD ALONG DOTTED LINE



Place
Stamp
Here



GRIZZLY INDUSTRIAL, INC.
P.O. BOX 2069
BELLINGHAM, WA 98227-2069



FOLD ALONG DOTTED LINE

Send a Grizzly Catalog to a friend:

Name _____
Street _____
City _____ State _____ Zip _____

TAPE ALONG EDGES--PLEASE DO NOT STAPLE

Free Manuals Download Website

<http://myh66.com>

<http://usermanuals.us>

<http://www.somanuals.com>

<http://www.4manuals.cc>

<http://www.manual-lib.com>

<http://www.404manual.com>

<http://www.luxmanual.com>

<http://aubethermostatmanual.com>

Golf course search by state

<http://golfingnear.com>

Email search by domain

<http://emailbydomain.com>

Auto manuals search

<http://auto.somanuals.com>

TV manuals search

<http://tv.somanuals.com>