

**GEMINI
PT-2000
HIGH-TORQUE
DIRECT-DRIVE
QUARTZ-LOCK
PROFESSIONAL
TURNTABLE**

INSTRUCTION MANUAL

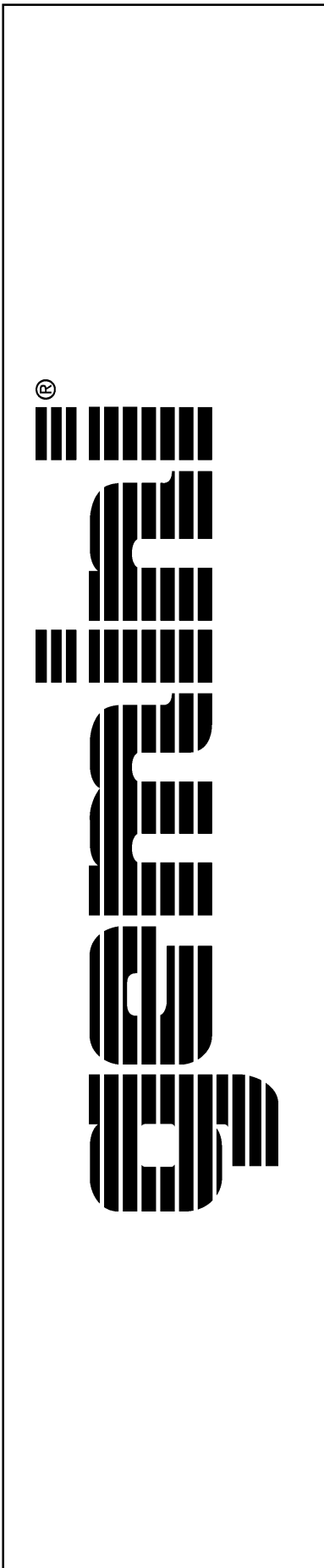
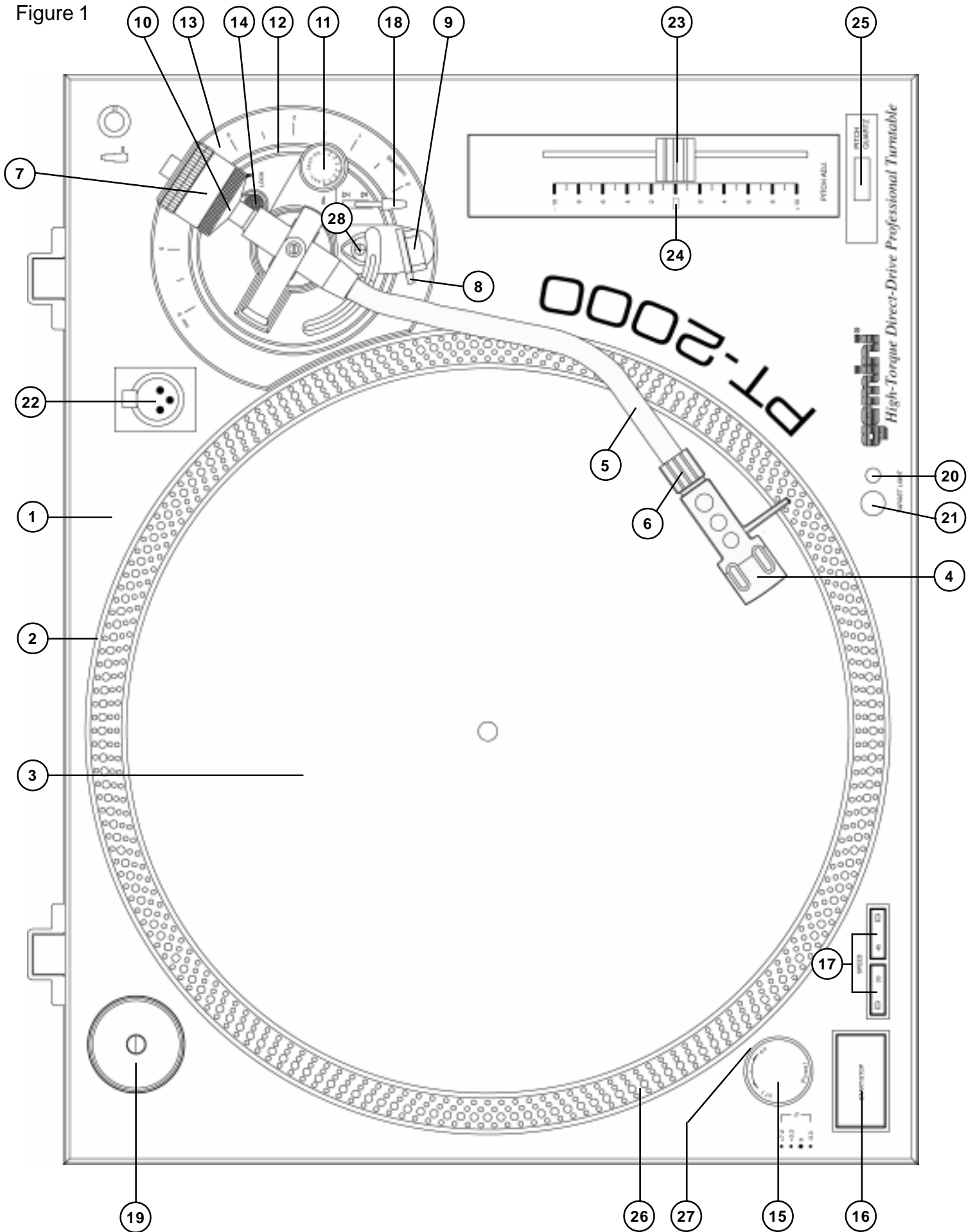

Figure 1



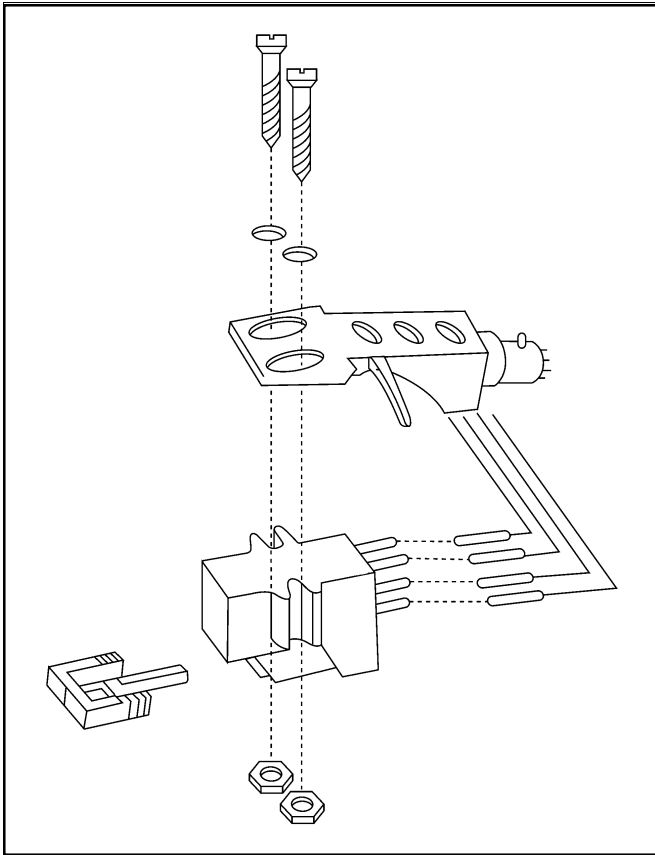

Figure 2

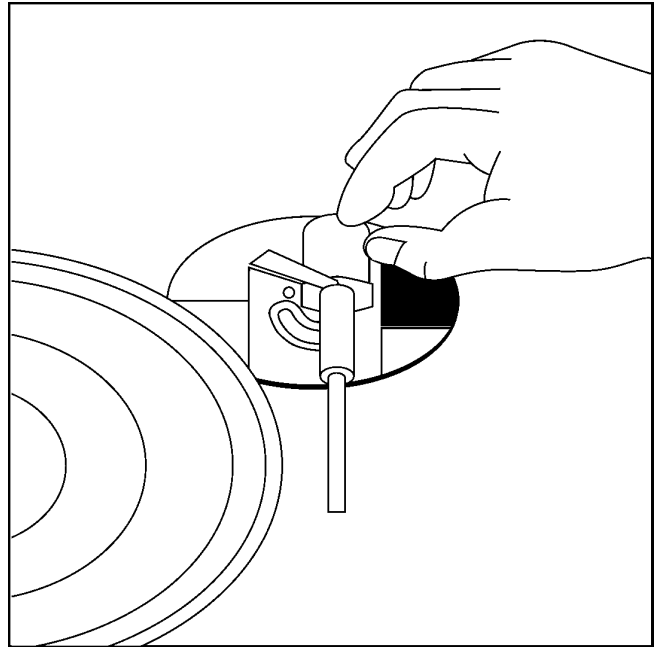

Figure 3A

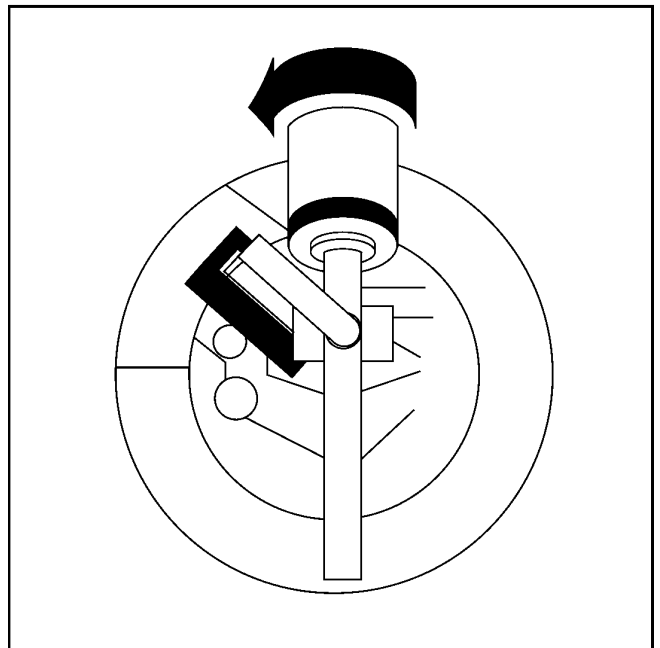

Figure 3B

Introduction

Congratulations on purchasing a Gemini PT-2000 high-torque professional turntable. This state of the art turntable includes the latest features in modern direct drive turntable technology. Prior to use, we suggest that you carefully read all the instructions.

Features

- Quartz locked speed
- +/- 10% Pitch control
- Fully electronic braking for quick stops
- Strobe illuminator
- Soft-touch start/stop switch

Precautions

1. Read all operating instructions before using this equipment.
2. To reduce the risk of electrical shock, do not open the unit. There are NO USER REPLACEABLE PARTS INSIDE. Please contact the Gemini Service Department or your authorized dealer to speak to a qualified service technician.
3. Tone Arm bearings are factory set and sealed. Any attempt at adjustment will void the warranty.
4. Be sure that all AC power is OFF while making connections.
5. Cables should be low capacitance, shielded and of proper length. Make sure that all plugs and jacks are tight and properly connected.
6. Always begin with the audio level faders/volume controls set at minimum and the speaker volume control(s) set to OFF. Wait 8 to 10 seconds prior to turning up the speaker volume to prevent the transient "POP" that could result in speaker/crossover damage.
7. DO NOT EXPOSE THIS UNIT TO RAIN OR MOISTURE.
8. DO NOT USE ANY SPRAY CLEANER OR LUBRICANT ON ANY CONTROLS OR SWITCHES.

Parts Checklist

Turntable unit.....	1
Dust cover hinge.....	2
Turntable platter.....	1
45 rpm adaptor.....	1
Rubber mat.....	1
Counter balance.....	1
Dust cover.....	1
Headshell.....	1

Assembly and Set-Up

NOTE: SEE FIG. 1 (PAGE 1) FOR PART NUMBERS AND LOCATIONS.

TURNTABLE PLATTER INSTALLATION:

Set the **TURNTABLE BASE (1)** on a flat, level surface. After checking to ensure that all packing materials have been removed, gently place the **PLATTER (2)** on the center spindle of the **TURNTABLE BASE (1)**. Put the **RUBBER MAT (3)** on the **PLATTER (2)**.

CARTRIDGE INSTALLATION: (SEE FIG. 2)

Because all cartridges have their own designs, please refer to your particular cartridge's instructions to insure proper installation.

1. Connect the lead wires to the cartridge terminals. For your convenience, the terminals of most cartridges are color coded. Connect each lead wire to the terminal of the same color.
 - White (L+).....Left Channel +
 - Blue (L-).....Left Channel -
 - Red (R+).....Right Channel +
 - Green (R-).....Right Channel -
2. Mount the cartridge in the **HEADSHELL (4)** and tighten it with the screws included with the cartridge.

ATTENTION STANTON 680 CARTRIDGE USERS

When using a Stanton 680 or similar cartridge, where the body is grounded to a cartridge terminal, remove the grounding strap from the cartridge body to the cartridge ground terminal. Failure to do this may result in excessive hum.

HEADSHELL INSTALLATION:

Insert the **HEADSHELL (4)** into the front of the tubular **TONE ARM (5)**. While holding the **HEADSHELL (4)** firmly in a horizontal position, turn the **LOCKING NUT (6)** clockwise until the **HEADSHELL (4)** is locked in place.

COUNTERWEIGHT INSTALLATION: (SEE FIG. 3A & 3B)

1. Slide the **COUNTERWEIGHT (7)** onto the rear of the **TONE ARM (5)**.
2. Twist the **COUNTERWEIGHT (7)** lightly counterclockwise, to screw it onto the rear of the **TONE ARM (5)**.

ADJUSTING HORIZONTAL ZERO (0) BALANCE AND STYLUS PRESSURE:

1. Without touching the stylus tip, remove the stylus protector (if your cartridge has a detachable one).
2. Release the **ARM CLAMP (8)** and lift the **TONE ARM (5)** off the **ARM REST (9)**.
3. Counter clockwise advancement of the **COUNTERWEIGHT (7)** will cause the cartridge side of the **TONE ARM (5)** to be lowered. Clockwise will cause the opposite. Turn the **COUNTERWEIGHT** clockwise or counter clockwise as needed until the **TONE ARM** is balanced horizontally. You can easily tell this by watching for the point where the **TONE ARM** "floats" freely.

- Place **TONE ARM (5)** on **ARM REST (9)** and lock it in place with the **ARM CLAMP (8)**.
- With the **TONE ARM (5)** locked on the **ARM REST (9)**, hold the **COUNTERWEIGHT (7)** steady with one hand while rotating the **STYLUS PRESSURE RING (10)** until the numeral "0" on the ring aligns with the center line on the **TONE ARM (5)** rear shaft. The horizontal zero (0) balance should be completed.
- Refloat the **TONE ARM** to ensure horizontal zero (0) balance. If zero balance has not been maintained, repeat counterweight steps 3 - 5.
- After adjusting the horizontal zero (0) balance, turn the balanced **COUNTERWEIGHT (7)** counter clockwise until the cartridge manufacturer's recommend stylus pressure appears on the **STYLUS PRESSURE RING (10)** where it meets the center line of the **TONE ARM (5)** rear shaft.

ADJUSTING THE ANTI-SKATING CONTROL:

Set the **ANTI-SKATING CONTROL (11)** to the same value as the stylus pressure.

ADJUSTING TONE ARM HEIGHT:

The tone arm height is adjustable between 0 and 6 mm. A **HEIGHT SCALE (13)** (in 0.5 mm increments) is provided to aid in an accurate setting.

- Unlock the tone arm by turning the **ARM LOCK (14)** knob away from the lock position.
- Look up the cartridge height on Table A and find its corresponding height scale reading.
- Turn the **HEIGHT ADJUSTMENT RING (12)** until the reference line on the ring is positioned at the correct scale reading.
- Lock the tone arm by turning the **ARM LOCK (14)** knob clockwise until it reaches the lock position.

TABLE A

CARTRIDGE HEIGHT (mm)	SCALE READING
15	0
16	1
17	2
18	3
19	4
20	5
21	6

For example, if the height of the cartridge is 18.5 mm, the **ARM HEIGHT ADJUSTMENT RING (12)** reference line should be positioned between 3 and 4 on the **HEIGHT SCALE (13)**.

INSTALLING THE DUSTCOVER:

- Hold the dustcover in position, directly above the turntable, and slide the hinge bases into the holders mounted on the rear panel.
- Always raise the dustcover before removal.
- Avoid opening and closing the dustcover during play. Undesirable vibration and stylus skipping can result.

UNIT PLACEMENT:

- Place unit on a flat, vibration free surface. Use the turntable feet to horizontally stabilize the unit.
- Try to place the unit as far away from the speakers as possible.

- Keep the unit away from direct exposure to the sun, heat, moisture or dirt.
- Keep the unit well ventilated.

CONNECTIONS:

- Plug the AC power plug into an appropriate outlet.
- See Table B for proper connection of the output RCA plugs and ground connector. Make sure that all the plugs are firmly plugged into the appropriate jacks. To reduce hum, make sure the ground lug is firmly connected to the ground screw.

TABLE B

OUTPUT CONNECTORS	MIXER OR RECEIVER
L (WHITE)	PHONO L CHANNEL
R (RED)	PHONO R CHANNEL
GND (Spade Lug)	GND Screw

Operating Instructions

BASIC OPERATION:

- Place a record on the **RUBBER MAT (3)** which sits on the **PLATTER (2)**.
- Select the desired speed by depressing the 33 or 45 **SPEED SELECTOR BUTTON (17)**.
- Turn the **POWER SWITCH (15)** to the "ON" position, at which point the strobe illuminator (built into the **POWER SWITCH (15)**) and the speed indicator (for the selected speed) will illuminate.
- Remove the stylus protector (if applicable to your cartridge).
- Release the **ARM CLAMP (8)** found on the **ARM REST (9)**.
- Push the **START STOP BUTTON (16)**. The turntable **PLATTER (2)** will start to spin.
- Push the **CUE LEVER (18)** to the "UP" position.
- Position the tone arm over the desired position on the record and push the **CUE LEVER** to the "DOWN" position. The **TONE ARM (5)** will slowly lower onto the record at which time play will begin.
- When play is over, raise the **TONE ARM (5)**, move it to the **ARM REST (9)**, and secure it with the **ARM CLAMP (8)**.
- You now have the option of turning off the power by turning the **POWER SWITCH (15)** to the "OFF" position, or stopping the **PLATTER (2)** by pushing the **START STOP BUTTON (16)** and engaging the electronic brake.

INTERRUPTING PLAY:

- Pushing the **CUE LEVER (18)** to the "UP" position will cause the **TONE ARM (5)** to lift stopping play.
- Pushing the **CUE LEVER (18)** to the "DOWN" position will cause the **TONE ARM (5)** to slowly lower onto the record at the point where play was interrupted.

PLAYING 45 RPM RECORDS:

- When playing a 45 rpm record with a large center hole, first place the **45 ADAPTOR (19)** on the center spindle.
- Be sure that the 45 **SPEED SELECTOR BUTTON (17)** is pushed and the 45 speed indicator is illuminated.

TARGET LIGHT:

1. Push the **TARGET LIGHT SWITCH (20)** firmly and the **TARGET LIGHT (21)** will raise into position and illuminate the stylus tip.
2. To lower the **TARGET LIGHT**, push down on it until it locks in the casing.
3. When not being used, the **TARGET LIGHT** should be kept in the lowered position.

XLR LAMP ADAPTOR:

1. Plug a gooseneck light with an XLR base, like the GEMINI GNL-500, into the **XLR LAMP ADAPTOR (22)**.
2. When the power is turned on, the light will illuminate.

ADJUSTING THE PITCH CONTROL:

1. The PT-2000 is equipped with **PITCH CONTROL (23)** and **QUARTZ LOCK (25)**. When the **QUARTZ LOCK** is activated, the **PITCH LED (24)** lights **GREEN**, and the speed will be exactly 33 1/3 or 45 RPM depending on which **SPEED SELECTOR BUTTON (17)** is pushed. **PITCH CONTROL** automatically disengages when **QUARTZ LOCK** is activated.
2. When the **QUARTZ LOCK** is off, you can adjust the **PITCH CONTROL(23)**. When you move **PITCH CONTROL (23)** off center, the pitch can vary +/- 10% depending on the position of the **PITCH CONTROL**.
3. Push the **QUARTZ LOCK (25)** button to bring the speed back to exactly 33 1/3 or 45 RPM when the **PITCH CONTROL (23)** is positioned off center. Disengaging the **QUARTZ LOCK (25)** will bring the platter speed back to the original pitch setting.
4. The **PLATTER (2)** is equipped with a **STROBE RPM INDICATOR STRIP (26)** and the **POWER SWITCH (15)** contains built in **STROBE LIGHTS (27)**. When the **PLATTER (2)** is spinning, the **STROBE LIGHTS** illuminate the **STROBE RPM INDICATOR STRIP (26)**. The bottom row of dots will appear to be stationary when the speed of the platter is exactly 45 RPM. The second row from the bottom will appear to be stationary at 33 1/3 RPM.

ARM-LIFT HEIGHT ADJUSTMENT:

If the pre-adjusted distance that the **CUE LEVER (18)** raises the stylus off the record surface is inadequate, it can be adjusted by turning the **ARM-LIFT HEIGHT ADJUSTMENT SCREW (28)** while simultaneously pushing down on the **TONE ARM (5)**. Clockwise rotation of the screw will decrease the distance and counterclockwise rotation will increase the distance.

Specifications

TURNTABLE SECTION:

Type.....	Quartz Direct Drive Manual Turntable
Drive Method.....	Direct Drive
Motor.....	Brushless DC Motor 18V
Platter.....	Aluminum Diecast 11 1/2" (332mm) Dia. Weight.....2 lbs. (0.9 Kg)
Speed.....	33 1/3 or 45 RPM
Starting Torque.....	1.5 Kg/cm (1.3 lb/in)
Build-up Characteristics.....	0.6 sec. standstill to 33 1/3 RPM
Braking System.....	Electronic Brake
Wow and Flutter.....	0.01% WRMS*
* This rating refers to the turntable assembly and platter only and excludes effects of records, cartridges or tonearms.	
Rumble.....	78 dB (IEC 98A WTD)

TONEARM SECTION:

Type.....	Universal S-Shaped Tubular Arm
Effective Length.....	9 1/16" (230.1 mm)
Arm Height Adjust Range.....	0 - 6 mm
Overhang.....	19/32" (15.2 mm)
Effective Mass.....	9 g (Without Cartridge)
Offset Angle.....	22°
Friction.....	Less Than 7 mg (Lateral, Vertical)
Tracking Error Angle.....	Within 2°32' at the outer groove and within 0°32' at the inner groove of a 30 cm (12") record
Stylus Pressure Adjust Range.....	0 - 2.5 g
Applicable Cartridge Weight Range.....	6 - 10 g
Headshell Weight.....	5.6 g

GENERAL:

Power Supply.....	115V 60Hz or
Power Supply.....	230V 50Hz
Power Consumption.....	15 Watts
Dimensions.....	17 1/2" x 6 1/4" x 14" 444.5mm x 158.75mm x 355.6mm
Weight.....	25 lbs. (11.34 Kg)

Specifications are subject to change without notice. The weight and dimensions shown are approximate.



**In the USA: If you experience problems with this unit,
call 1-732-738-9003 for Gemini Customer Service.**

Do not attempt to return this equipment to your dealer.

Parts of the design of this product may be protected by worldwide patents.

Information in this manual is subject to change without notice and does not represent a commitment on the part of the vendor. Gemini Sound Products Corp. shall not be liable for any loss or damage whatsoever arising from the use of information or any error contained in this manual.

No part of this manual may be reproduced, stored in a retrieval system or transmitted, in any form or by any means, electronic, electrical, mechanical, optical, chemical, including photocopying and recording, for any purpose without the express written permission of Gemini Sound Products Corp.

It is recommended that all maintenance and service on this product is performed by Gemini Sound Products Corp. or its authorized agents.

Gemini Sound Products Corp. will not accept liability for loss or damage caused by maintenance or repair performed by unauthorized personnel.

Worldwide Headquarters • 120 Clover Place, Edison, NJ 08818 • USA
Tel: (732) 738-9003 • Fax: (732) 738-9006

France • G.S.L. France • 11, Avenue Leon Harmel, Z.I. Antony, 92160 Antony, France
Tel: + 33 (0) 1 55 59 04 70 • Fax: + 33 (0) 1 55 59 04 80

Germany • Gemini Sound Products GmbH • Ottostrasse 6, 85757 Karlsfeld, Germany
Tel: 08131 - 39171-0 • Fax: 08131 - 39171-9

UK • Gemini Sound Products • Unit C4 Hazleton Industrial Estate, Waterlooville, UK P08 9JU
Tel: 087 087 00880 • Fax: 087 087 00990

Spain • Gemini Sound Products S.A. • Mino, 112, Nave 1, 08223 Terrassa, Barcelona, Spain
Tel: 011-34-93-736-34-00 • Fax: 011-34-93-736-34-01

Free Manuals Download Website

<http://myh66.com>

<http://usermanuals.us>

<http://www.somanuals.com>

<http://www.4manuals.cc>

<http://www.manual-lib.com>

<http://www.404manual.com>

<http://www.luxmanual.com>

<http://aubethermostatmanual.com>

Golf course search by state

<http://golfingnear.com>

Email search by domain

<http://emailbydomain.com>

Auto manuals search

<http://auto.somanuals.com>

TV manuals search

<http://tv.somanuals.com>