

PMX-7®

STEREO PRE-AMP MIXER

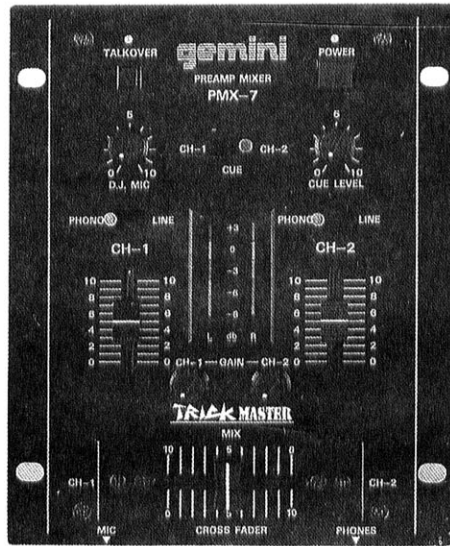

INSTRUCTION MANUAL

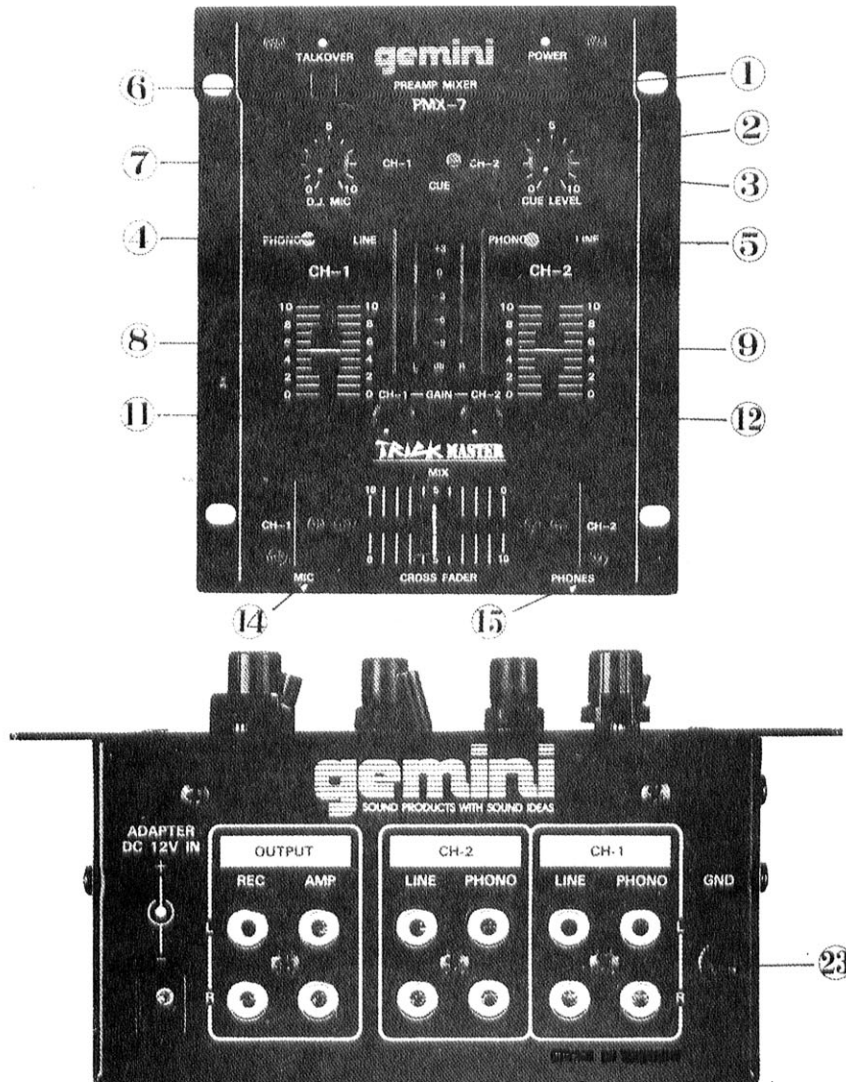

PMX-7

INTRODUCTION

We congratulate you on choosing a Gemini Sound Products mixer. You will find that its front panel design makes using it very simple.

The latest advances in mixer technology have been utilized in manufacturing. Making this mixer the ideal brain of any audio system.

We have incorporated many features to make you, the DJ, present a professional product. You will find using it fun no matter how it is used, on the go, in the club, or at home.

To obtain maximum performance from your mixer please read all instructions carefully before operating

4

INSTRUCTIONS FOR CONNECTIONS

1. Be sure that the POWER (1) is in the off position. All connections must be made with the equipment off.
2. This unit comes supplied with a 12 volt AC ADAPTER. Plug the MALE PIN cord into the back of the mixer (22). Then plug the adapter's AC CORD into the proper power source. (European adapters are available upon request).
3. For best sound use only high quality phono cables when hooking up equipment to the mixer. Make sure that all cables are pushed in securely.
4. When hooking up the amplifier use the OUTPUT AMP (18) jacks. Make sure you correctly attach the left and right cables.
5. If you desire to record your mix, connect the OUTPUT RECORD (19) jacks to the input of your reel to reel or cassette deck. The record output will vary as you raise and lower the channel volume controls (8) and (9) **&/or gain controls(11,12)**
6. The unit is equipped with one microphone input. The MIC (14) input jack is located on the front of your mixer. TALK (6) switch will reduce the overall volume of the mix without effecting the microphone volume.
7. **Up to two turntables may be attached to this mixer. Inputs for PHONO 1 (21) PHONO 2 (16) are on the back panel of your mixer. PHONO/LINE (4, 5) switches must be set to phono in order for the turntable sound to come through your system. Volume for each Channel is controlled by the CH-1 (8) and CH-2 (9) slide controls &/or gain controls(11,12)**

8. Tuners, cassette decks, reel to reels, video equipment, compact disc and any other line/aux level inputs may be connected to this mixer, through the LINE (17, 20) inputs located on the back panel. PHONO/LINE (4, 5) switches must be set to line in order for sound to come out through the mixer. Volume for each channel is controlled by the CH-1 (8) CH-2 (9) SLIDE CONTROLS &/or gain controls(11,12)

OPERATING INSTRUCTIONS

1. POWER On: Once you have made all connections to your mixer press the POWER (1) button.
2. MICROPHONE ADJUSTMENT. MIC volume is controlled by raising or lowering the **mic control (7)**. With the TALK (6) switch in the talk position the volume of all sources except the mic volume will be reduced by 16dB. In the off position all volumes return to normal.
3. This mixer is provided with a GROUND (23) connection which can be found on the back panel of your mixer. Most audio components come supplied with a ground wire. If so, connect the ground wire to the GROUND (23) connection. This will eliminate most hums and feedbacks.

4. PHONO/LINE selection: By moving the PHONO/LINE (4, 5) switches to the appropriate position you can choose which source will play through the mixer at any give time.

5. REMOVABLE FADER (13): the FADER mixes one channel into another. You can select which CH-1 and CH-2 will play through the fader

To Change new fader as follow:

- 1) REMOVE THE FADER KNOB (A) BY PULLING UP.
- 2) UNSCREW THE OUTSIDE FADER PLATE SCREWS (B) DO NOT TOUCH THE INSIDE SCREWS (C).
- 3) CAREFULLY LIFT THE FADER AND UNPLUG THE CABLE (D)
- 4) PLUG THE NEW FADER INTO THE CABLE AND PLACE IT BACK INTO THE MIXER
- 5) SCREW THE FADER TO THE MIXER
- 6) RETURN THE FADER KNOB TO ITS ORIGINAL POSITION

6. GAIN(11,12):Allows you to preset the channels to the same volume, by using the headphones, while both channel slides(8,9)are in the same position.

NOTE:We recommend using the maximum position on channel slides(8,9).

7. CUE assign(2):By connecting a headphone to the PHONE jack(15) you can monitor the mixex. cue assign(2)allows hearing of either channel and CUE LEVEL(3) controls the headphone volume.

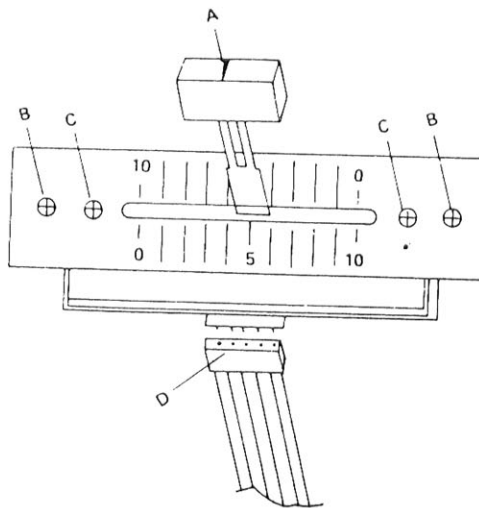

★ **NOTE:** REPLACEMENT FADERS can be purchased at your local dealer. Available in two lengths (30mm & 45mm).

6

WARNINGS

1. All operating instructions should be read before using this equipment.
2. To reduce the risk of electrical shock, do not remove cover or back. No user – serviceable parts inside. Refer servicing to a qualified service technician.
3. Do not expose to direct sunlight or heat sources: such as radiators, stoves, or other appliances that produce heat.
4. This unit should be cleaned only with a damp cloth. Avoid solvents or other cleaning detergents.
5. When moving this equipment is should be placed in its original carton and packing. This will reduce the risk of damage in transit.

SPECIFICATIONS

Inputs:

Microphone: 1.5mV 600 ohm

Phono: 3mV 47K ohm

Line: 150mV 27K ohm

Output: 7V Peak To Peak maximum.

Frequency response: 20-20,000Hz \pm 2dB

Distortion: 0.08%

S/N ratio: more than 70dB

Attenuation to the "TALKOVER": - 16 dB

Headphone monitor impedance: 16 ohm

Power source: DC 12V 500mA

Dimensions: 166(L) \times 200(W) \times 80(H)mm

6 1/2" (L) \times 7 7/8" (W) \times 3 1/4" (H)

Free Manuals Download Website

<http://myh66.com>

<http://usermanuals.us>

<http://www.somanuals.com>

<http://www.4manuals.cc>

<http://www.manual-lib.com>

<http://www.404manual.com>

<http://www.luxmanual.com>

<http://aubethermostatmanual.com>

Golf course search by state

<http://golfingnear.com>

Email search by domain

<http://emailbydomain.com>

Auto manuals search

<http://auto.somanuals.com>

TV manuals search

<http://tv.somanuals.com>