

# OWNER'S MANUAL

# HEX™

SERIES

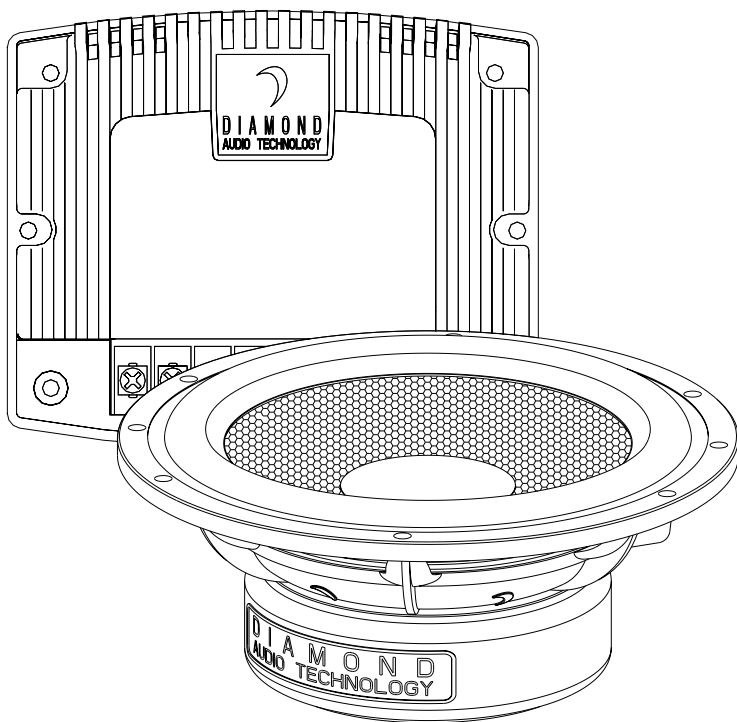

System covered:

**S6.0mx3**

6" (160mm)

Midbass Component Add-On



**DIAMOND**  
AUDIO TECHNOLOGY

Converts an S400/500 system to passive 3-way operation.

The following diagram shows a typical connection of the **S6.0mx3** Midbass Add-On to the **S400** or **S500** systems. In this manner, a fully passive 3-way speaker system may easily be assembled. Optionally, the RAF output of the *primary* HEX crossover may still be used to augment the front stage sound. The **Sx3** crossover features selectable highpass frequencies of 200 or 400Hz @ 6dB/oct, plus level controls to balance the bass/mid/high sound. For Bi-amping through the **Sx3** (not shown), simply connect the additional amp channels to the corresponding INPUT 2 terminals. Then, move the internal switches #3 & #4 to the **BIAMP=ON** position. **FAILURE TO SO MAY CAUSE DAMAGE TO THE AMPS.** Note: INPUT 1 passes audio to the WOOFER output, INPUT 2 to the HIGHPASS output.

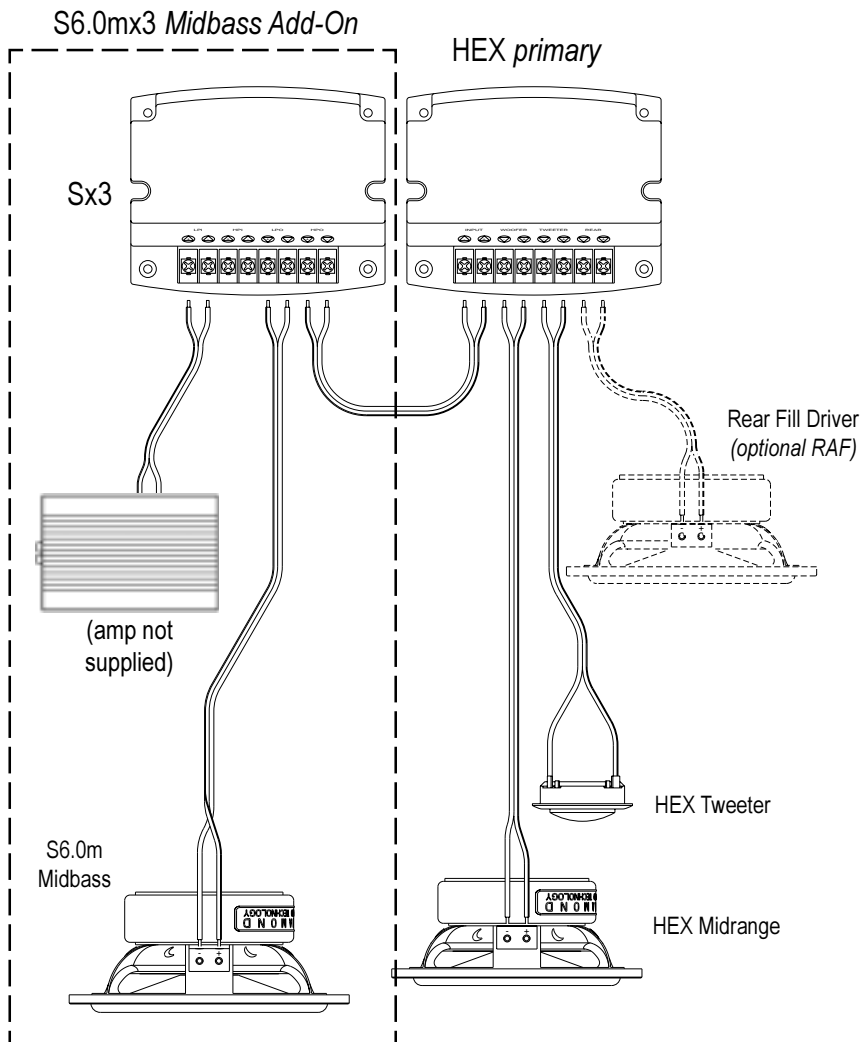

**“Technical...”**

**S6.0m  
HEX™ Cone  
Midbass/Woofer**

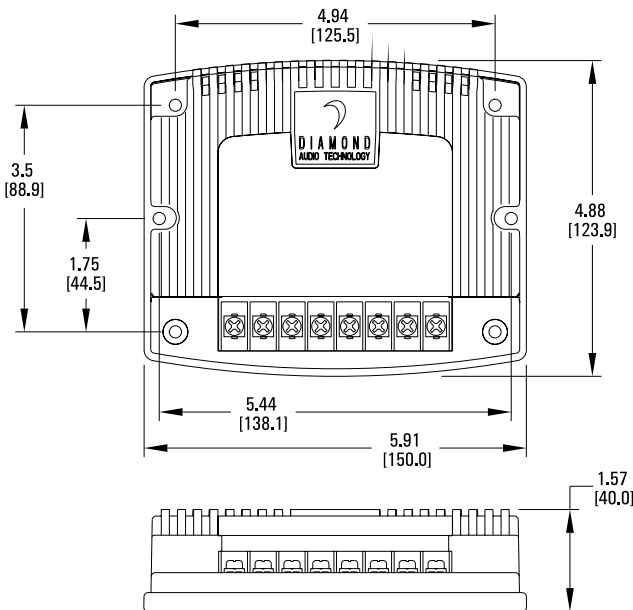
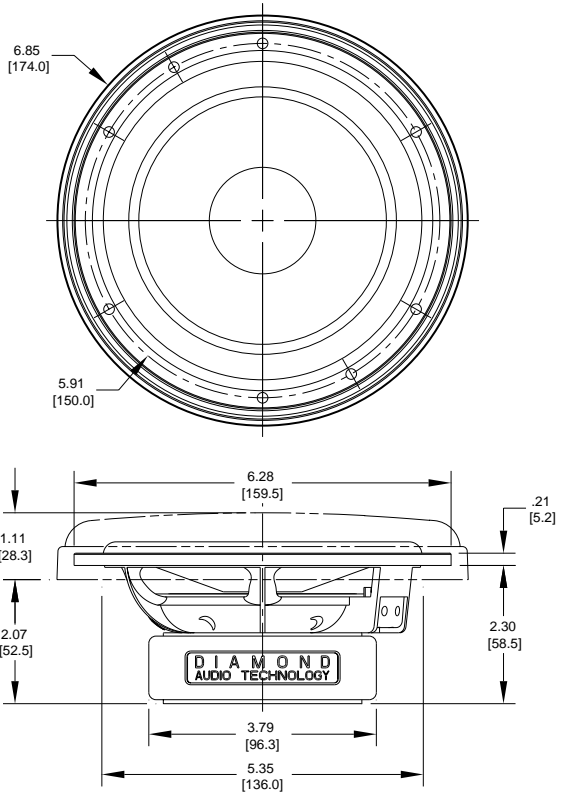

**Sx3  
250Hz Midbass  
Crossover**

## ⚡ LIMITED WARRANTY STATEMENT ⚡

Diamond Audio Technology, Inc. (DAT) warrants all DAT products to be free of defects in material and workmanship for a period of **one (1) year** from the date of original purchase provided they are purchased from an authorized DAT retailer in the United States. However, the effective warranty period will be **three (3) years** if the products were purchased from and installed by an authorized DAT retailer.

**WHAT IS COVERED:** Parts and labor to effect repair or, at the sole discretion of DAT, replacement of either any malfunctioning or defective part(s) or the entire system should the system or any component part(s) thereof fail to perform as designed. Includes return freight via ground transportation to destinations within the United States.

**WHAT IS NOT COVERED:** Installation or setup and repair or replacement of the system or any parts thereof which, in DAT's judgement, fail or become damaged as a result of negligence, improper use, abuse, unauthorized modification or service, improper or inadequate packaging during shipment, installation by a non-authorized dealer, accident, or use for any purpose other than those for which this product was originally intended, or where the model's serial number has been removed, altered or defaced.

**WHO IS COVERED:** Original purchaser so long as they reside in the United States and can provide proof of the original date of purchase (e.g., store receipt) from an authorized DAT retailer.

**OUTSIDE THE UNITED STATES:** Customers outside the United States should contact their local sales office to obtain information on prices, exchange unit availability, instructions, service and warranty/non-warranty repairs.

**REPAIR OR REPLACEMENT UNDER THIS WARRANTY IS THE EXCLUSIVE REMEDY OF THE CONSUMER. DAT SHALL NOT BE LIABLE FOR ANY INCIDENTAL OR CONSEQUENTIAL DAMAGES FOR BREACH OF ANY EXPRESSED OR IMPLIED WARRANTY ON THIS PRODUCT. EXCEPT TO THE EXTENT PROHIBITED BY APPLICABLE LAW, ANY IMPLIED WARRANTY OF MERCHANTABILITY OR FITNESS FOR A PARTICULAR PURPOSE ON THIS PRODUCT IS LIMITED IN DURATION TO THE DURATION OF THIS WARRANTY.**

Some states do not allow the exclusion or limitation of incidental or consequential damages, or allow limitations on how long an implied warranty lasts, so the above limitations or exclusions may not apply to you. This warranty gives you specific legal rights and you may also have other rights that may vary from state to state.

**HOW TO OBTAIN WARRANTY SERVICE:** In the event a DAT product should require servicing, you should (a) visit an authorized DAT retailer or (b) call the DAT Service Dept. at (310) 582-8942. To be eligible for warranty service within a three (3) year period, the accompanying receipt of original purchase from an authorized DAT retailer must specifically note that dealer installation was provided.

Product returned for repair/service must be properly packaged and clearly marked with the Return Authorization (RA) number issued by DAT. If the RA number is not clearly marked on the package or no RA number was issued by DAT, the product may be refused upon delivery. DAT does not assume responsibility for lost or misdirected product. ■



**Diamond Audio Technology, Inc.**

3030 Pennsylvania Ave.

Santa Monica, CA 90404

Tel: 310.582.1121

Fax: 310.582.1502

## Free Manuals Download Website

<http://myh66.com>

<http://usermanuals.us>

<http://www.somanuals.com>

<http://www.4manuals.cc>

<http://www.manual-lib.com>

<http://www.404manual.com>

<http://www.luxmanual.com>

<http://aubethermostatmanual.com>

Golf course search by state

<http://golfingnear.com>

Email search by domain

<http://emailbydomain.com>

Auto manuals search

<http://auto.somanuals.com>

TV manuals search

<http://tv.somanuals.com>