

DELTECH

Installation, Operation and Maintenance Manual

HYDROBLOC LS SERIES HEATLESS COMPRESSED AIR DRYER

**MODEL
LS60 through LS2580**

**This instruction manual must be read by everyone
who installs or works with this equipment**

Contents

HYDROBLOC LS SERIES SPECIFICATIONS

Section 1 General Information

1.1	Foreword	1 - 1
1.2	General System Information	1 - 1
1.2.1	Dryer	1 - 1
1.2.2	Prefilter Assembly	1 - 1
1.2.3	Automatic Drain Valves	1 - 2
1.2.4	Afterfilter Assembly	1 - 2

Section 2 Installation

2.1	Receiving and Inspection	2 - 1
2.2	Equipment Handling	2 - 1
2.3	Mechanical Set-Up	2 - 1
2.4	General Piping Information	2 - 2
2.5	Purge Exhaust Restrictor	2 - 3
2.6	Purge Exhaust Muffler	2 - 3
2.7	Electrical Connection	2 - 3
2.8	Remote Alarm Connection	2 - 5
2.9	Equipment Check	2 - 5
2.10	Instrumentation	2 - 6

Section 3 Operation

3.1	How It Works	3 - 1
3.2	Automatic Drain Valve	3 - 1
3.3	Initial Start-Up For Dryers With Fixed Cycle Electronic Timer Controls (Models LS60 through LS1000 only)	3 - 1
3.4	Initial Start-Up For Dryers With DEC Controller Dryer Models LS60 through LS1000	3 - 3
	Dryer Models LS1250 and LS1500	3 - 4
	Dryer Models LS2070 and LS2580	3 - 5
3.5	Normal Start-Up or Restart For Dryers With Fixed Cycle Electronic Timer Control (Models LS60 through LS1000 only)	3 - 7
3.6	Normal Start-Up or Restart For Dryers With DEC Controller Dryer Models LS60 through LS1000	3 - 7
	Dryer Models LS1250 and LS1500	3 - 8
	Dryer Models LS2070 and LS2580	3 - 8
3.7	Normal Operational Checks	3 - 9
3.8	Dryer Shutdown	3 - 9

Contents

Section 4	Maintenance and Repair	
4.1	Preventative Maintenance Schedule	4 - 1
	Weekly	4 - 1
	Quarterly	4 - 1
	Semi-Annually	4 - 1
	Annually	4 - 2
4.2	Desiccant Charging Procedures	4 - 2
4.3	Filter Element Replacement	4 - 3
	Dryer Models LS60 through LS1250	4 - 3
	Dryer Models LS1500 through LS2580	4 - 4
4.4	Servicing The Internal Float Drain Valve (If Equipped)	4 - 4
4.5	Automatic Drain Valve Disassembly and Servicing	4 - 5
4.6	Moisture Indicator Recharging Procedure	4 - 7
4.7	Inlet and Purge Exhaust Switching Valve Maintenance (LS60 through LS760)	4 - 8
4.8	Inlet and Purge Exhaust Switching Valve Maintenance (LS1000)	4 - 10
4.9	3" Inlet Switching Valve Maintenance (Models LS1250 and LS1500)	4 - 12
4.10	2" Purge Exhaust Switching Valve Maintenance (Model LS1250 only)	4 - 14
4.11	3" Purge Exhaust Switching Valve Maintenance (Model LS1500 only)	4 - 16
4.12	Purge and Outlet Check Valve Maintenance (Models LS60 through LS760)	4 - 18
4.13	3" Purge and Outlet Check Valve Maintenance (Models LS1000 through LS1500)	4 - 20
4.14	Remote Flow Restrictor Maintenance (Model LS1250 only)	4 - 22
4.15	Flow Restrictor Maintenance (Models LS1500 through LS2580)	4 - 23
4.16	Purge Adjusting Valve (Models LS2070 and LS2580)	4 - 26
4.17	Pilot Gas Filter Maintenance (Models LS2070 and LS2580)	4 - 27
Section 5	Troubleshooting Guide	
Appendix A	Purge Curves	
Appendix B	Replacement Parts	
Appendix C	Specifications, Purge Curves and Replacement Parts for -100°F Pressure Dew Point Dryers	

HYDROBLOC LS SERIES SPECIFICATIONS

STANDARD DESIGN OPERATING CONDITIONS

MODEL	FLOW CAPACITY ¹ (scfm)
LS60	60
LS110	110
LS130	130
LS185	185
LS240	240
LS270	270
LS360	360
LS505	505
LS630	630
LS760	760
LS1000	1000
LS1250	1250
LS1500	1500
LS2070	2070
LS2580	2580

Operating Pressure	<u>60 psig</u>	minimum
	<u>150 psig</u>	maximum
Operating Temperature	<u>40° F</u>	minimum
	<u>120° F</u>	maximum
Inlet Moisture Content	<u>Saturated</u>	(at specified inlet pressure)
Outlet Moisture Content	<u>-40</u>	°F Dew Point @ line pressure

¹ Based on 100°F inlet air temperature and -40°F pressure dew point. Maximum recommended inlet temperature, 120°F. For capacity at inlet temperature higher than 100°F, consult your local distributor.

DETAIL SPECIFICATIONS:

Dryer Cycle:	NEMA Cycle	<u>6 minutes</u>
	Drying	<u>3 minutes</u>
	Regeneration	<u>3 minutes</u>
Dryer Adsorbent:	Type	<u>DE-4 Activated Alumina</u>
Pressure Vessels:	ASME Section VIII, DIV. 1 Stamped	
	Design Pressure	<u>175 psig (minimum)</u>
	Design Temperature	<u>450° F</u>
Dryer:	Operation	<u>Automatic</u>
	Pressure Drop	<u>.5 TO 5 psid @ 100 psig and 100° F</u>
	Purge Source	<u>Dryer Outlet</u>

UTILITIES:

Electrical:	NEMA Type	<u>NEMA 4X</u>
	Input	<u>115V, 60 HZ, 1 PH</u>
	Power Consumption	<u>40 WATTS</u>

HYDROBLOC LS SERIES SPECIFICATIONS

MODEL	PREFILTER	AFTERFILTER
LS60	D-0100-CF	D-0100-PF
LS110	D-0175-CF	D-0100-PF
LS130	D-0175-CF	D-0170-PF
LS185	D-0250-CF	D-0170-PF
LS240	D-0250-CF	D-0300-PF
LS270	D-0400-CF	D-0300-PF
LS360	D-0400-CF	D-0405-PF
LS505	D-0600-CF	D-0510-PF
LS630	D-0600-CF	D-0850-PF
LS760	D-0750-CF	D-0850-PF
LS1000	D-1000-CF	D-1020-PF
LS1250	D-1200-CF	D-1225-CF
LS1500	D-1500-CF	D-1500-PF
LS2070	D-2000-CF	D-2000-PF
LS2580	D-3000-CF	D-3000-PF

1

General Information

1.1 Foreword

This manual is designed to serve as the installation, operation, and maintenance guide for your dryer system. The contents of this manual should be carefully read BEFORE attempting any phase of installation, operation or maintenance. Failure to follow the operating and maintenance procedures of the instruction manual could result in personal injury or property damage.

To facilitate maintenance, a "Recommended Spare Parts List" is included in the manual for your specific dryer model. Failure to maintain recommended spare parts and filter cartridges may result in EXPENSIVE and unnecessary downtime, for which the manufacturer cannot be responsible. To request a quotation, or place an order for recommended or emergency spare parts, please contact your local Deltech Sales Representative.

A Dryer Specification Label has been permanently attached to the inside cover of the dryer control enclosure. When requesting information, service, ordering of spare parts, etc., please reference all information supplied on the Specification Label.

All information, specifications and illustrations within this manual are those in effect at the time of printing. The manufacturer reserves the right to change or make improvements without incurring any obligation to make changes or add improvements to products previously sold.

1.2 General System Information

CAUTION: The Deltech Hydrobloc LS Series heaterless regenerative desiccant dryer system is designed to sequentially remove contaminants. The Prefilter removes liquid and particulate contaminants, the Dryer removes vaporous contaminants and the Afterfilter removes any remaining particulates. Bypass of any component in the system compromises the whole system.

CAUTION: Each component of a Deltech Hydrobloc LS Series heaterless regenerative desiccant dryer system has been selected to compliment the performance of the other components of the system. Therefore, use of unauthorized parts or supplies or improper operation will degrade system performance.

1.2.1 Dryer

This fully automatic, heaterless-type dryer alternately cycles the compressed, process gas flow through two desiccant-filled, vertical chambers where the gas's entrained, vaporous moisture content is adsorbed. One desiccant chamber is always on-stream in a timed DRYING CYCLE throughout normal dryer operation. The opposite, off-stream chamber is in a timed REGENERATION CYCLE for removal of the desiccant's previously adsorbed moisture content or in a static or steady state pressurized condition. The dryer's "fail-safe" design feature provides continued process gas flow through both desiccant chambers if the control system's power supply is lost or interrupted.

1.2.2 Prefilter Assembly

As the first line of defense against oil/water contaminants a Deltech D-Series Coalescing Prefilter with an automatic drain is required.

The Deltech D-Series Coalescing Prefilter Assembly removes oil and water aerosols, as well as dirt and pipe scale from the gas stream BEFORE the gas enters the dryer. Oil and liquids collected by the assembly's filter cartridges fall to the housing sump which must be periodically drained.

1.2.3 Automatic Drain Valves

As previously stated, the accumulated water and oil mixture collected by a prefilter must be periodically drained from the prefilter housing sump. A Deltech Automatic Drain Valve is a recommended and reliable means of removing collected moisture, oil and sludge from coalescing prefilter housings and other components requiring periodic draining.

1.2.4 Afterfilter Assembly

The Deltech D-Series Particulate Afterfilter Assembly is another feature offered. Even under the most ideal conditions, all regenerative type desiccant dryers tend to generate small quantities of micron-sized desiccant dust particles. This highly abrasive contaminant can erode instruments, valve seats, air cylinders and pneumatic tools. A Deltech D-Series Particulate Afterfilter Assembly installed downstream of your desiccant dryer will remove desiccant dust, pipe scale and other harmful particulates before the gas stream continues to points-of-use.

2 Installation

2.1 Receiving and Inspection

Immediately upon receipt of the dryer, thoroughly inspect for damage that may have occurred during shipment. Since the dryer is shipped F.O.B. Ocala, Florida, the carrier is legally responsible for damage incurred during shipping. Shipping damage is not covered by the dryer warranty.

If goods are received short or damaged, notify the carrier and insist on a notation of the loss on the face of the bill of lading. Otherwise no claim can be enforced against the carrier.

If concealed loss or damage is discovered, notify the carrier at once and request an inspection. The carrier will make an inspection and grant a concealed damage notation. The carrier will not consider any claim for loss or damage unless an inspection has been made. If you give the carrier a clear receipt for goods that have been damaged or lost in transit, you do so at your own risk and expense.

If there is any damage, file a claim with the carrier, contact your local distributor or the factory before attempting to install subject equipment.

2.2 Equipment Handling

Note: Should questions arise concerning site selection, installation, operation, etc., please contact your local Deltech Sales Representative for assistance.

WARNING!

Use appropriate, load rated lifting equipment, and observe safe lifting procedures during all moves. The unit should be carefully unloaded as close as is possible to final installation site to minimize chances of equipment damage. Refer to the drawings enclosed with this manual for equipment shipping weight.

Dryer models LS15 through LS1500 are designed to be moved by means of forklift slotting at the base of the dryer's protective shipping framework and lifting straps installed on the dryer.

Dryer models LS2070 and LS2580 are designed to be moved by means of lifting lugs supplied on the desiccant chambers.

2.3 Mechanical Set-Up

Important: When selecting an installation site, consideration must be given to the need for adequate clearances around and above the dryer system for ease of maintenance and accessibility. Site selection should also take into account possible momentary sound levels in excess of 85 decibels during each desiccant chamber depressurization period.

1. Locate the dryer system in an area with adequate clearance for servicing of all components. The recommended clearance around the dryer system should be a minimum of four (4) feet. An overhead clearance of not less than two (2) feet above each desiccant chamber is required for desiccant filling. Refer to the drawings enclosed with this manual for dimension, connection and weight specifications applicable to your specific dryer system.
2. Remove all protective shipping framework, covers, pipe plugs, shipping blocks, etc.
3. Utilizing the base plate mounting holes provided, anchor the dryer to a solid, level foundation designed to support the dryer's dead weight loading, plus any earthquake or wind loadings, as required.
4. Suitable protective barriers are recommended to reduce the possibility of accidental damage if the unit is located in an open area, or in close proximity to vehicular and pedestrian traffic.

2.4 General Piping Information

NOTE 1: Use the proper pressure rated piping, fittings and valves as approved by ASME, ANSI, ASA, etc. Separate or special requirements by local and/or municipal codes may also apply.

NOTE 2: The manufacturer is not liable for code violations, downtime, component failure or consequential damages to customer supplied components and/or equipment.

NOTE 3: Where it is undesirable to interrupt process flow, a redundant system with block valves should be installed to permit servicing and maintenance of the dryer and associated filter assemblies. The recommended block valve **MUST** be of a type which will provide bubble-tight shut-off. Ball, globe or butterfly valves with soft seats are suitable for this purpose. **DO NOT USE PLUG OR GATE VALVES.**

NOTE 4: All inlet and outlet connections, valve and inter-connecting piping **MUST** be of the same size as the dryer's gas inlet connection or larger. The manufacturer and its affiliates are not liable for excessive pressure drops and loss of capacity caused by undersized or incorrectly installed piping and/or piping components. Refer to Table 2.1 for inlet and outlet connection sizes for your dryer system.

NOTE 5: Carefully inspect all piping lengths and components **BEFORE** installation. Remove any internal oil, water, dirt, or debris which may have accumulated during shipment and/or storage.

NOTE 6: Leakage from piping connections and/or associated components installed upstream of the dryer will cause a loss of gas pressure and unnecessary compressor cycling. The **slightest** leakage from piping connections and/or associated components installed downstream of the dryer's outlet connection can easily cause a degradation of the dried gas dew point. The use of TFE tape on all male pipe threads and the application of sufficient torque at assembly will greatly reduce chances of leakage and subsequent rework.

1. All external piping must be supplied by the customer unless otherwise specified. Refer to Table 2.1 for connection sizes. Inlet and outlet manual shut-off valves and a vent valve are recommended so the dryers and filters can be isolated and depressurized for servicing. Refer to Figure 2.1 for recommended piping layout.
2. Be sure all piping is supported. Do not allow the weight of any piping to bear on the dryer or filters.

**Table 2.1
CONNECTIONS**

Model	FO1 Connections ¹ (Inches)		F02/FO7 Connections ² (Inches)	
	Inlet	Outlet	Inlet	Outlet
LS60	1" NPT	¾" NPT	1" NPT	1" NPT
LS110	1¼" NPT	¾" NPT	1" NPT	1" NPT
LS130	1¼" NPT	1" NPT	1" NPT	1" NPT
LS185	1½" NPT	1" NPT	1" NPT	1" NPT
LS240	1½" NPT	1¼" NPT	1½" NPT	1½" NPT
LS270	1½" NPT	1¼" NPT	1½" NPT	1½" NPT
LS360	1½" NPT	1½" NPT	1½" NPT	1½" NPT
LS505	2½" NPT	2" NPT	2" NPT	2" NPT
LS630	2½" NPT	2½" NPT	2" NPT	2" NPT
LS760	2½" NPT	2½" NPT	2" NPT	2" NPT
LS1000	3" FLG	2½" NPT	3" FLG	3" FLG
LS1250	3" FLG	3" FLG	3" FLG	3" FLG
LS1500	4" FLG	4" FLG	4" FLG	4" FLG
LS2070	4" FLG	4" FLG	4" FLG	4" FLG
LS2580	4" FLG	4" FLG	4" FLG	4" FLG

Model	FO1 Connections ¹ (Inches)		F02/FO7 Connections ² (Inches)	
	Inlet	Outlet	Inlet	Outlet
LSC60	¾" NPT	¾" NPT	1" NPT	1" NPT
LSC110	1" NPT	¾" NPT	1" NPT	1" NPT
LSC130	1" NPT	¾" NPT	1" NPT	1" NPT
LSC185	1¼" NPT	¾" NPT	1" NPT	1" NPT
LSC240	1¼" NPT	1" NPT	1" NPT	1½" NPT
LSC270	1¼" NPT	1" NPT	1" NPT	1½" NPT
LSC360	1½" NPT	1¼" NPT	1" NPT	1½" NPT
LSC505	2" NPT	1¼" NPT	1½" NPT	2" NPT
LSC630	2" NPT	1½" NPT	1½" NPT	2" NPT
LSC760	2½" NPT	2" NPT	2" NPT	2" NPT
LSC1000	2½" NPT	2½" NPT	2" NPT	2" NPT
LSC1250	3" FLG	3" FLG	3" FLG	3" FLG
LSC1500	3" FLG	3" FLG	3" FLG	3" FLG
LSC2070	4" FLG	4" FLG	4" FLG	4" FLG
LSC2580	4" FLG	4" FLG	4" FLG	4" FLG

¹ FO1 – Standard mounted filter package

² F02 /F07 – Optional mounted filter packages

3. Purge Exhaust Piping is not required on Models LS60 through LS1500. However, if it is necessary to have a remote mounted muffler, consult with your local Deltech Sales Representative for special piping instructions.

On Models LS2070 and LS2580, refer to the Purge Exhaust Muffler Section of the manual for Purge Exhaust Piping instructions.

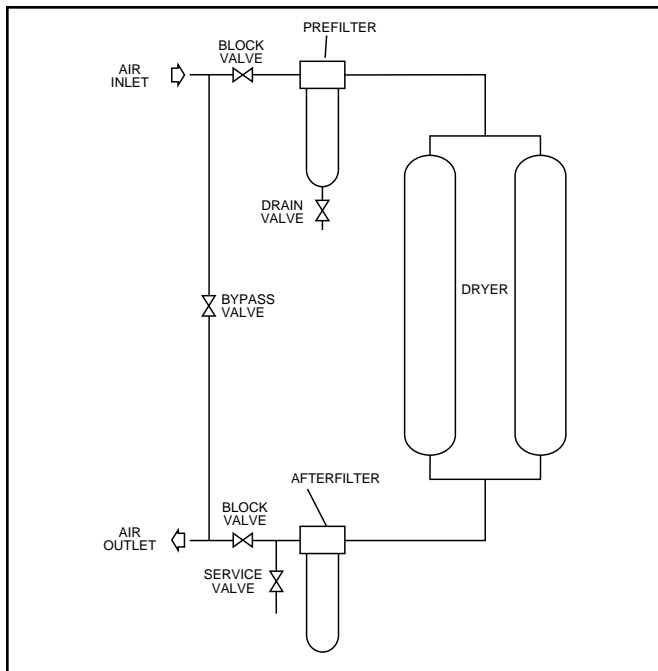

Figure 2.1
RECOMMENDED PIPING LAYOUT

2.5 Purge Exhaust Restrictor

The dryer's Purge Exhaust Restrictor quiets the gas flow and prevents desiccant bed fluidization by controlling (slowing) the rate of depressurization.

On dryer models LS60 through LS1000 the Purge Exhaust Restrictor is designed into the Purge Exhaust Valve.

On dryer models LS1250 through LS2580 the Purge Exhaust Restrictor must remain attached to the purge exhaust switching valve body to operate properly.

2.6 Purge Exhaust Muffler

The dryer's Purge Exhaust Muffler quiets the gas flow to atmosphere during depressurization and regeneration (purge) cycles.

On models LS2070 and LS2580, the purge exhaust muffler must be piped **BY THE CUSTOMER** to a remote location. A removable section of pipe should be provided at the Purge Exhaust Restrictor for ease of maintenance and the muffler should be mounted in a self-draining position.

Note: The pipe run from the dryer to the muffler should not exceed 100 equivalent feet of pipe using a pipe size equal to or larger than the Purge Exhaust Restrictor connection. Consult with your local Deltech Sales Representative for requirements when the equivalent feet of pipe exceeds 100 feet.

2.7 Electrical Connection

NOTE 1: Use proper, load-rated components as approved by NEC, NEMA, CSA, UL, etc., as required. Local and municipal codes may also apply. All installations and connections must be in accordance with recognized electrical codes in effect.

NOTE 2: It is mandatory that each dryer be individually GROUNDED. Do not use your plant's frame as a ground. Use an adequate ground with the conductor sized to NEC.

NOTE 3: A disconnect switch is not provided as standard equipment and therefore, must be supplied by the customer. The dryer's electrical load is indicated on the Dryer Specification Label located on the inside cover of the dryer control enclosure.

NOTE 4: The manufacturer is not liable for code violations, component damage, downtime or consequential damages related to customer supplied and installed electrical components and connections.

NOTE 5: Exercise CAUTION for Static Sensitive Devices before making electrical connections.

NOTE 6: DRYER CONTROLS FOR HAZARDOUS LOCATIONS. Optima dryer controls for hazardous locations comply with the National Electrical Code (NEC) for application in Class I, Division 2, Group B through D hazardous locations. Per NEC 501-3 (b), *all incendive devices (power supply, common alarm relay, fuse) that may release enough energy to ignite B through D gases and vapors are located in a NEMA 7 enclosure. Also, all non-incendive devices (solenoid valves, DIP switch and pressure switch contacts) that do not normally release enough energy to ignite B through D gases and vapors, are located in a NEMA 4 enclosure.*

1. For dryers equipped with an electronic timer, the dryer is pre-wired and ready to use and is fitted with a power cord. Refer to the dryer-mounted Specification Plate or the Dryer Specification Sheet located in the front of this manual for your specific dryer model's electrical input requirements. Connect the dryer to the power supply specified on the data plate.
2. For dryers equipped with the Hydrobloc DEC controller, refer to the Dryer Specification Label, (located on the inside cover of the dryer control enclosure) for your specific dryer model's electrical input requirements. ENSURE THAT THE INTENDED POWER SOURCE CONFORMS TO THESE REQUIREMENTS.

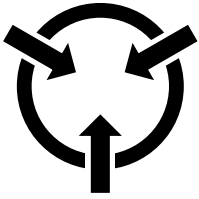

CAUTION

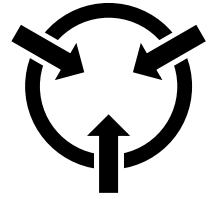

STATIC SENSITIVE DEVICES

STATIC SENSITIVE DEVICES CAN BE DAMAGED BY ELECTROSTATIC DISCHARGE. YOU CAN MINIMIZE THE CHANCES OF DESTROYING SUCH DEVICES BY:

1. KNOWING THAT THERE IS A POTENTIAL STATIC SENSITIVE PROBLEM.
2. ADHERING TO THE GUIDELINES LISTED BELOW FOR HANDLING THEM.
3. USING RECOMMENDED PACKAGING AND BENCH TECHNIQUES.

FOLLOW THESE PRACTICES TO MINIMIZE DAMAGE TO STATIC SENSITIVE DEVICES.

1. DO NOT WELD ON THIS EQUIPMENT AND/OR ASSOCIATED PIPING. THE CONTROL IS SENSITIVE TO ELECTRICAL GROUND LOOP VOLTAGES.
2. DISCHARGE PERSONAL STATIC BEFORE HANDLING DEVICE. (USE GROUNDING WRIST STRAP.)
3. MINIMIZE HANDLING.
4. HANDLE STATIC SENSITIVE DEVICES BY THE BODY ONLY. DO NOT TOUCH ANY CONNECTORS. (USE MICROCHIP EXTRACTION AND INSERTION TOOLS.)
5. KEEP PARTS IN ORIGINAL CONTAINERS UNTIL READY FOR USE.
6. DO NOT SLIDE STATIC SENSITIVE DEVICE OVER ANY SURFACE.
7. USE ANTISTATIC CONTAINERS FOR HANDLING AND TRANSPORT.
8. KEEP PLASTIC, VINYL AND POLYSTYRENE FOAM OUT OF THE WORK AREA.
9. WHEN REMOVING ASSEMBLIES HANDLE ONLY BY NONCONDUCTIVE EDGES AND NEVER TOUCH OPEN CONNECTORS EXCEPT AT A STATIC FREE WORK STATION. PLACING SHORTING STRIPS ON CONNECTOR USUALLY PROVIDES COMPLETE PROTECTION TO INSTALLED STATIC SENSITIVE DEVICES.
10. HANDLE STATIC SENSITIVE DEVICES ONLY AT A STATIC-FREE WORK STATION.
11. USE ONLY ANTISTATIC TYPE SOLDER-SUCKERS.
12. USE ONLY GROUNDED TIP SOLDERING IRONS.

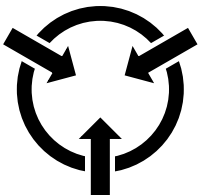

STATIC SENSITIVE SYMBOL

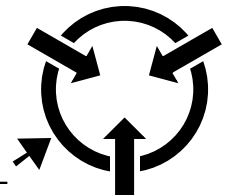

CAUTION: Surges, spikes and input voltage of less than eighty-five (85) VAC or greater than one hundred and thirty-two (132) VAC, may cause the Dryer Control System to operate erratically, or malfunction. This malfunction may or may not be accompanied by an alarm. Adequate surge, spike, brownout, and blackout protection must be provided to protect your equipment and allow safe shutdown time (an uninterrupted power supply is recommended). Failure to do so may result in wet pilot gas entering the control enclosure and damage to the equipment. Failure to provide adequate protection to the input voltage will void warranties.

3. Using the conduit connection ports provided, connect the electrical input and ground leads to the Power Input and Remote Alarm Terminal Block. Make connections in accordance with the lead connection inscriptions (**GND, H, N**). Connect ground lead (**GND**) **FIRST**.

NOTE: For hazardous locations, the Power Input and Remote Alarm Terminal Block are located in the NEMA 7 enclosure.

CAUTION: Do not make any additional wiring connections to terminals H, N, or GND on the POWER INPUT.

CAUTION: Do not remove the factory programmed microcomputer chip or any I.C. chip from the logic control circuit board. Improper removal will cause irreparable damage to these highly static-sensitive components. Damage to these components will render the dryer control system inoperative until replacement is accomplished by a Deltech Field Service Engineer. Do not remove the program identification sticker from the microcomputer chip.

WARNING!

DIP switches within the control box have been preset at the factory to conform to customer operating conditions. Any tampering with DIP switches will void warranty and may reduce the quality of the product gas. Any adjustments of DIP switches should only be made by a qualified Deltech Field Service Engineer.

2.8 Remote Alarm Connection

WARNING!

Most standard air and gas dryers are furnished with contacts for remote alarms. These contacts should be wired to an audible alarm and/or to an area where they are continuously monitored. When these contacts are not used, the dryer must be visually checked every two (2) hours for existence of any possible malfunction. Failure to do so may result in an upset condition that could damage the equipment. Failure to protect the dryer from aerosols and liquid condensate will void warranties.

1. Remote alarm terminals (A1, A2, A3) located on the Remote Alarm Terminal Block are provided for connection of a customer-supplied remote alarm circuit (if desired). Should an alarm situation or loss of the dryer's power supply occur, the remote alarm relay will de-energize to transfer contact from A3 to A2 for remote alarm actuation.

Note: A customer supplied separate power source of sufficient voltage, (not to exceed 120 VAC) must be connected to terminal A1 for remote alarm actuation.

CAUTION: The total current rating of all customer supplied remote alarm equipment **MUST NOT** exceed 6 amperes inductive, and 10 amperes resistive. Do not make any additional wiring connections to terminals A1, A2, and A3.

2.9 Equipment Check

1. Vibration during shipment can cause loosening of fittings and fasteners. Therefore, inspect the dryer for alignment, connection and tightness of all subassemblies, etc.
2. Remove shipping plugs from desiccant chamber fill ports (2). Apply TFE tape to threads and install relief valves (2).

Note: Pressure relief valves are offered as accessories and are shipped separately.

3. On Models LS60 through LS1500 desiccant is normally installed prior to shipment unless otherwise specified by the customer. On Models LS2070 and LS2580 desiccant is shipped loose.

Tapping on each chamber with a soft-face mallet will yield a deadened sound if desiccant has been installed. If a hollow sound is noted, the chambers are empty and require installation of desiccant prior to operation. Refer to the Desiccant Charging Procedure in the Maintenance and Repair section of this manual, if charging is necessary.

CAUTION: Dryer models covered within the scope of this manual are designed to use a specific desiccant. Use of any other size or type may reduce efficiency or damage the dryer.

CAUTION: Do not hydrostatically test the dryer with desiccant installed. All pressure vessels are factory tested at one and one-half (1-1/2) times the design pressure. Hydrostatic testing will damage the dryer's desiccant charge.

4. While exercising caution for Static Sensitive Devices, open the Dryer Control System Enclosure Cover and inspect as follows:
 - a) Check all terminal block wiring connections. **Do not over tighten terminal block lug screws.**

- b) Close the dryer control system enclosure cover and tighten all cover latches.

CAUTION: Do not remove the factory programmed micro-computer chip or any I.C. chip from the logic control circuit board. Improper removal will cause irreparable damage to these highly static-sensitive components. Damage to these components will render the dryer control system inoperative until replacement is accomplished by a Deltech Field Service Engineer. Do not remove the program identification sticker from the microcomputer chip.

WARNING!

DIP switches within the control box have been preset at the factory to conform to customer operating conditions. Any tampering with DIP switches will void warranty and may reduce the quality of the product gas. Any adjustments of DIP switches should only be made by a qualified Deltech Field Service Engineer.

2.10 Instrumentation

The following instrumentation helps in monitoring dryer operation and performance. Instruments which are available as options are so noted.

Fixed Cycle Electronic Timer Control

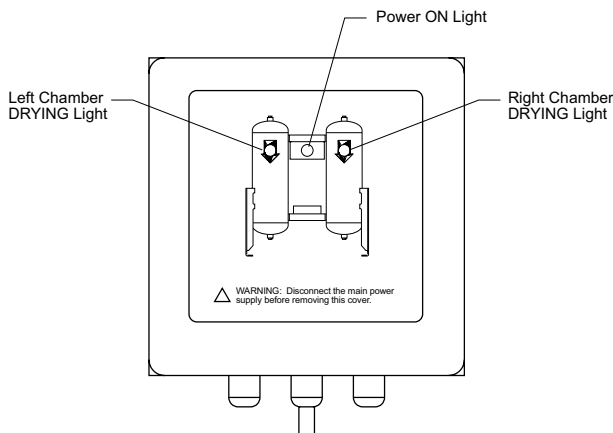

Figure 2.2
Hydrobloc LS Series Electronic Timer Control Indicating Panel

Power ON Light

The power ON light on the control panel indicates when the dryer is turned on and operating.

Left Chamber DRYING Light

The Left Chamber DRYING light on the control panel indicates when the left chamber is drying.

Right Chamber DRYING Light

The Right Chamber DRYING light on the control panel indicates when the right chamber is drying.

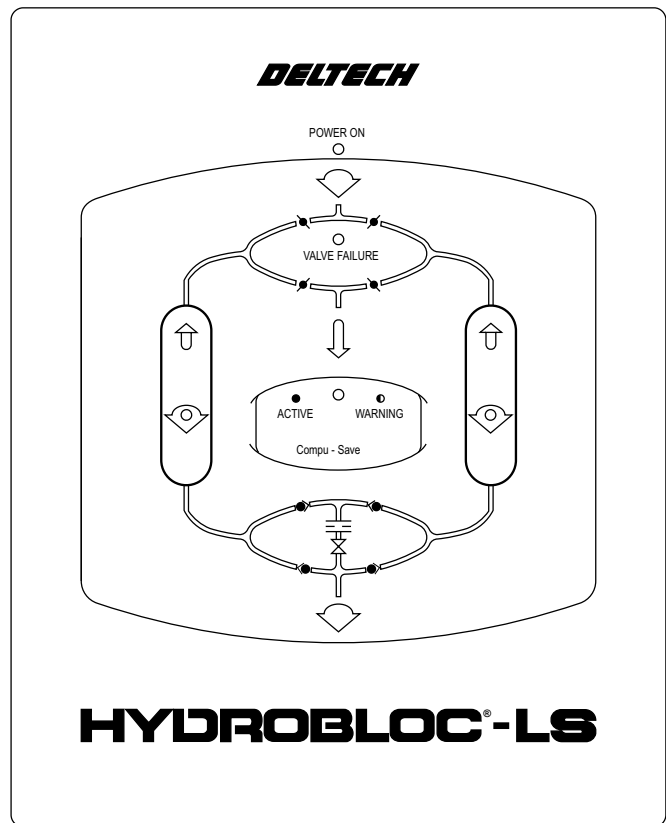

Figure 2.3
Hydrobloc DEC Indicating Panel

Hydrobloc LS DEC Controller

Hydrobloc LS Series dryers are equipped with a microprocessor system that controls the operation of all dryer functions. The controller is programmed to operate on a 6 minute cycle for -40°F pdp dryers (4 minute for -100°F pdp dryers). The controller keeps the drying chamber on-line for 3 minutes (2 minutes for -100°F pdp) while simultaneously regenerating the off-line chamber. Indicators on the controller (Figure 2.3) help in monitoring dryer operation and performance. Instruments which are available as options are so noted.

Deltech Compu-Save Energy Management System (Option B)

The optional DEC Compu-Save Energy Management System automatically adjusts dryer operation to compensate for changes in operating conditions. Air samples are periodically taken from within each vessel and passed over a capacitance probe which senses both temperature and relative humidity. The dew point of the air within the desiccant bed is then precisely determined. While the dryer continues to operate on a fixed drying cycle, the regeneration cycle will not be initiated until a predetermined set point has been reached. Purge air consumption is reduced to a minimum.

The DEC Compu-Save Energy Management System is active when the Energy Management System LED indicator is ON.

When the Energy Management System LED indicator is OFF, the dryer either does not have the Compu-Save Energy Management System option, or that the sensor has determined that the relative humidity in the on-line chamber has reached the predetermined set point. At next switchover, that chamber will regenerate using purge air.

When the Energy Management System LED indicator is flashing, a high humidity condition may exist or there is an Energy Management System failure.

Left Chamber DRYING Light

The Left Chamber DRYING light on the DEC control panel indicates when the left chamber is drying.

Right Chamber DRYING Light

The Right Chamber DRYING light on the DEC control panel indicates when the right chamber is drying.

Valve Switching Failure (Option A & B)

This alarm is triggered when the drying chambers are not in the correct pressure state. The chamber pressure switch should be open on the on-stream chamber and closed on the regenerating chamber. If triggered, the dryer control system will energize the red LED on the DEC control panel labeled VALVE FAILURE and de-energize the common alarm relay. The alarm automatically clears once the alarm conditions are corrected.

Chamber Pressure Gauges

A gauge mounted on the inlet valve block (models LS60 through LS1500) or panel mounted (models LS2070 and LS2580) indicates which chamber is on-stream and which is regenerating. The gauge for the on-stream chamber indicates operating pressure; the gauge for the regenerating chamber should indicate 0 psig.

Purge Flow Indicator

A locally mounted gauge indicates purge air pressure as an approximate measure of purge air flow when used with the appropriate calibration curve found in Appendix A (for -100°F pdp refer to Appendix C).

Moisture Indicator (Option A & B)

An indicator utilizing specially treated "silica gel" which changes color to alert personnel of a moisture problem requiring corrective action. The indicator is blue when dry, but gradually changes to pink in color whenever a "wet gas" sample is received.

3 Operation

3.1 How It Works

Incoming air or gas is first passed through the system pre-filter to remove liquid water and oil contaminants. The dryer then removes vaporous contaminants. The dryer's cycle control system alternately cycles the compressed gas flow through the unit's twin desiccant chambers. As the vapor-laden gas supply enters and flows downward through a desiccant chamber, the contaminant vapors are attracted to and adsorbed on the surface of the activated desiccant.

Adsorption is an exothermic (heat releasing) process, the heat which later contributes to regeneration. Dry gas exits the dryer to an afterfilter for particulate removal. The clean and dry gas then proceeds downstream into the compressed air system.

While one desiccant chamber is in the Drying Cycle previously described, the opposite, off-stream chamber depressurizes and proceeds through a fixed time, atmospheric pressure, regeneration cycle using a portion of the dry outlet process air at the design dew point. This outlet air is expanded through an orifice, further reducing the dew point. This extremely dry purge gas, in conjunction with the heat of adsorption, regenerates the bed. Upon completion of the regeneration cycle, the desiccant chamber will repressurize and once again be placed on-stream for another drying cycle.

The dryer control system utilizes its pilot gas supply to position the dryer's inlet and purge switching valves as required for the cycle at hand.

3.2 Automatic Drain Valve

All Hydrobloc LS Series dryers are equipped with an electronic drain valve that automatically discharges condensate from the prefilter.

The automatic drain valve has two LED indicators and a test button to help verify operation. Pushing the test button causes the drain port to click open. One LED indicates

that power is supplied to the drain valve; the other LED indicates that the drain port is open. The power indicator turns off when the drain port opens. If either LED fails to turn on at the proper time, refer to the maintenance section of this manual. If the dryer is under warranty, call your local representative for authorization before servicing.

Operation of the automatic drain valve is controlled by an electronic timer. The drain opening can be set from 0.5 to 10 seconds. The drain cycle can be set from 0.5 to 45 minutes.

To minimize air losses, the timer should be adjusted to open the port just long enough to discharge accumulated condensate. The timer is properly set if nothing but air vents at the end of the open period. If air vents for more than a few seconds, set the timer for a longer cycle or shorter drain opening. If liquid is still discharging when the port closes, set the timer for a shorter cycle or longer drain opening.

3.3 Initial Start-Up For Dryers With Fixed Cycle Electronic Timer Controls (Models LS60 through LS1000 only)

WARNING!

Ensure that the dryer is de-energized, valve isolated and fully depressurized before attempting to remove or disassemble any dryer component or subassembly. Failure to do so may result in serious personal injury and/or equipment damage.

CAUTION: Each component of a Deltech Regenerative Desiccant Dryer System has been selected to compliment the performance of the other components of the system. Therefore, use of unauthorized parts or supplies or improper operation will degrade system performance.

Once the Hydrobloc LS Series Dryer System has been installed according to instructions, it is ready to be operated. The system is fully automatic and does not require any auxiliary controls. It is designed to run continuously.

Do not start the dryer with compressed air flow through the dryer. Close customer supplied dryer shut-off valves before beginning start-up procedure.

1. Refer to the General Arrangement drawing as necessary for component identification and location while conducting start-up and operational procedures.

Note: If your dryer cannot be started, or fails to start due to special installation or other problems, contact your local Deltech Sales Representative for assistance.

2. Remove the Pilot Gas Filter Bowl. Verify that the pilot gas filter cartridge is installed. Replace Filter Bowl ensuring that O-ring is properly seated. Close the filter bowl bleed valve.
3. All Prefilter and Afterfilter Assemblies are shipped **WITH** filter cartridges installed. Verify that prefilter and afterfilter cartridges are installed. Prefilter and Afterfilter cartridges are **NOT** interchangeable and must be installed in their respective assemblies **ONLY**. The proper filter cartridge part number is listed on each Prefilter and Afterfilter Assembly.
4. Replace and tighten filter assembly bowls. Ensure that O-rings are properly seated.
5. Close any manual vent or drain valves installed in prefilter and afterfilter assemblies.
6. If the prefilter assembly was factory equipped with an automatic drain valve, inspect for, and remove pipe plug or cap which may have been installed in drain port for shipping purposes. Ensure isolation ball valve to automatic drain valve is open.
7. Ensure that all associated pipe and tubing connections, flanges, unions, plugs, mounting bolts, pipe hangers, etc., have been checked tight and/or properly secured.

IMPORTANT: It is recommended that the System's process gas output not be consumed or used at the intended points of use until the Start-Up and any related adjustments have been completed, and the system is producing process gas of the required quality. The quality of the process gas should be verified through test and analysis when a specific quality process gas is required.

8. Energize the dryer's electrical power supply.

The following indicator lights will illuminate:

- a) POWER ON
- b) LEFT or RIGHT CHAMBER DRYING

Note: Should the dryer experience a power interruption during a normal cycle, the unit will return to the same status of operation that existed at the time of the power interruption.

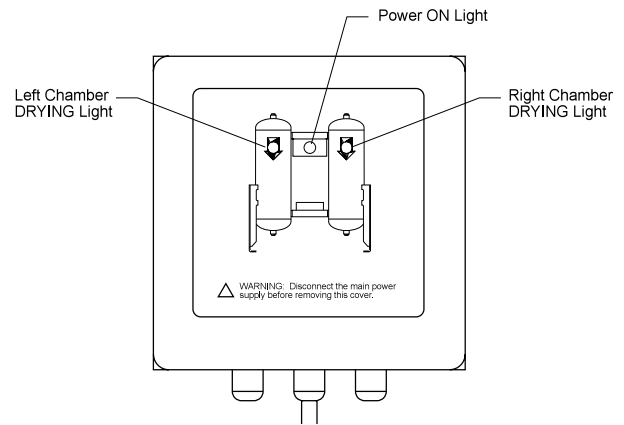

9. Supply pressure to system by slowly opening the System Inlet Isolation Valve (customer supplied). The Right Chamber Inlet Switching Valve and Left Chamber Purge Exhaust Switching Valve will close. The Left Chamber will immediately begin pressurizing to system pressure as indicated by the chamber pressure gauge.
10. The Moisture Indicator's (if dryer so-equipped) bleed valve is installed directly into the back of the indicator's body. Close the Indicator's Bleed Valve. FULLY open the Moisture Indicator Supply Valve.
11. Soap bubble test all external piping, fittings, and connections. Locate and repair all noted points of leakage. **Do not soap bubble test components located inside dryer control system's enclosure.**

Note: Small leaks noted in inlet piping to the dryer will not affect operation, other than a slight loss of pressure supplied to the dryer. HOWEVER, any gas leaks, (no matter how small), detected at, or downstream of the dryer outlet **MUST BE FIXED** to ensure that the dryer will provide a continuous supply of process gas at specified dew point, to intended points-of-use.

IMPORTANT: Water molecules can diffuse through a pinhole-size leak even though pressure inside the piping is several hundred PSIG. It is not uncommon to have a minute pinhole leak in a gas line cause an increase in dew point from -40°F to -10°F at a distance of forty or more feet downstream of the leak.

12. SLOWLY open the customer-supplied System Outlet Isolation Valve, while monitoring the Outlet Pressure Gauge (if dryer so-equipped). **DO NOT** permit the Dryer's Outlet Pressure Gauge to exceed a 5% drop in pressure while pressurizing downstream piping.
13. Close the customer-supplied System Bypass Valve (if installed).
14. Open and adjust the Moisture Indicator's Bleed Valve until a very slight, continuous gas bleed is felt exhausting from the bleed valve's exhaust port. Ensure that the granular indicator crystals remain motionless after final adjustment.

15. Refer to Appendix A (Appendix C for -100°F pdp) of this manual and calculate your dryer model's purge pressure setting as instructed.
16. Locate the Purge Adjusting Valve. Slowly rotate dryer's Purge Adjusting Valve until the Purge Pressure Indicator indicates the calculated purge pressure setting. (See following Note).

Note: The purge pressure can only be read and adjusted when an off-stream desiccant chamber has depressurized for regeneration. (When the off-stream chamber is pressurized, the Purge Pressure Indicator will read "system pressure".)
17. The Start-Up procedure for models LS60 through LS1000 is now complete. Proceed to the Normal Operation Checks section of this manual for final operational checks and adjustments.

3.4 Initial Start-Up For Dryers With DEC Controller

WARNING!

Ensure that the dryer is de-energized, valve isolated and fully depressurized before attempting to remove or disassemble any dryer component or subassembly. Failure to do so may result in serious personal injury and/or equipment damage.

CAUTION: Each component of a Hydrobloc LS Series Regenerative Desiccant Dryer System has been selected to compliment the performance of the other components of the system. Therefore, use of unauthorized parts or supplies or improper operation will degrade system performance.

Once the Hydrobloc LS Series Dryer System has been installed according to instructions, it is ready to be operated. The system is fully automatic and does not require any auxiliary controls. It is designed to run continuously.

Dryer Models LS60 through LS1000

Do not start the dryer with compressed air flow through the dryer. Close customer supplied dryer shut-off valves before beginning start-up procedure.

1. Refer to the General Arrangement drawing as necessary for component identification and location while conducting start-up and operational procedures.

Note: If your dryer cannot be started, or fails to start due to special installation or other problems, contact your local Deltech Sales Representative for assistance.
2. All Prefilter and Afterfilter Assemblies are shipped **WITH** filter cartridges installed. Verify that prefilter and afterfilter cartridges are installed. Prefilter and

Afterfilter cartridges are **NOT** interchangeable and must be installed in their respective assemblies **ONLY**. The proper filter cartridge part number is listed on each Prefilter and Afterfilter Assembly.

3. Replace and tighten filter assembly bowls. Ensure that O-rings are properly seated.
4. Close any manual vent or drain valves installed in prefilter and afterfilter assemblies.
5. If the prefilter assembly was factory equipped with an automatic drain valve, inspect for, and remove pipe plug or cap which may have been installed in drain port for shipping purposes. Ensure isolation ball valve to automatic drain valve is open.
6. Ensure that all associated pipe and tubing connections, flanges, unions, plugs, mounting bolts, pipe hangers, etc., have been checked tight and/or properly secured.

IMPORTANT: It is recommended that the System's process gas output not be consumed or used at the intended points of use until the Start-Up and any related adjustments have been completed, and the system is producing process gas of the required quality. The quality of the process gas should be verified through test and analysis when a specific quality process gas is required.

7. Supply compressed air up to System Inlet Isolation Valve.
8. Energize the dryer's electrical power supply.
9. Supply pressure to system by SLOWLY opening System Inlet Isolation Valve (customer-supplied). Both desiccant chamber Inlet Switching Valves will open and both chamber Purge Exhaust Valves will close. The desiccant chambers will immediately begin pressurizing to system pressure as indicated by chamber pressure gauges.
10. The Moisture Indicator's (if dryer so-equipped) bleed valve is installed directly into the back of the indicator's body. Close the Indicator's Bleed Valve. FULLY open the Moisture Indicator Supply Valve.
11. Soap bubble test all external piping, fittings, and connections. Locate and repair all noted points of leakage. **Do not soap bubble test components located inside dryer control system's enclosure.**

Note: Small leaks noted in inlet piping to the dryer will not affect operation, other than a slight loss of pressure supplied to the dryer. HOWEVER, any gas leaks, (no matter how small), detected at, or downstream of the dryer outlet **MUST BE FIXED** to ensure that the dryer will provide a continuous supply of process gas at specified dew point, to intended points-of-use.

IMPORTANT: Water molecules can diffuse through a pinhole-size leak even though pressure inside the piping is several hundred PSIG. It is not uncommon to have a minute pinhole leak in a gas line cause an increase in dew point from -40°F to -10°F at a distance of forty or more feet downstream of the leak.

12. SLOWLY open the customer-supplied System Outlet Isolation Valve, while monitoring the Outlet Pressure Gauge (if dryer so-equipped). **DO NOT** permit the Dryer's Outlet Pressure Gauge to exceed a 5% drop in pressure while pressurizing downstream piping.
13. Close the customer-supplied System Bypass Valve (if installed).
14. Open and adjust the Moisture Indicator's Bleed Valve until a very slight, continuous gas bleed is felt exhausting from the bleed valve's exhaust port. Ensure that the granular indicator crystals remain motionless after final adjustment.
15. Refer to Appendix A (Appendix C for -100°F pdp) of this manual and calculate your dryer model's purge pressure setting as instructed.
16. Locate the Purge Adjusting Valve. Slowly rotate dryer's Purge Adjusting Valve until the Purge Pressure Indicator indicates the calculated purge pressure setting. (See following Note).

Note: The purge pressure can only be read and adjusted when an off-stream desiccant chamber has depressurized for regeneration. (When the off-stream chamber is pressurized, the Purge Pressure Indicator will read "system pressure".)

For dryers with the Hydrobloc Compu-Save Energy Management System: During operation in the Energy Management Mode, the off-stream chamber may remain pressurized (in ENERGY MANAGEMENT ACTIVE). If this condition is noted, proceed as follows to adjust purge pressure.

- a) Open Dryer Control System Enclosure. Locate DIP switches on MEC CPU Board.
- b) Switch DIP switch position 7 to OFF position (down). De-energize dryer's electrical power supply for approximately fifteen (15) seconds; then re-energize. Dryer is now in Fixed Cycle Operation. The off-stream chamber will depressurize to atmosphere for regeneration.
- c) Calculate and set purge pressure as previously instructed.
- d) Return DIP switch position 7 to ON position. De-energize the dryer's electrical power supply for approximately fifteen (15) seconds; then re-energize. Dryer should be in Compu-Save Energy Saver Mode.

17. The Start-Up procedure for models LS60 through LS1000 is now complete. Proceed to the Normal Operation Checks section of this manual for final operational checks and adjustments.

Dryer Models LS1250 and LS1500

Do not start the dryer with compressed air flow through the dryer. Close customer supplied dryer shut-off valves before beginning start-up procedure.

1. Refer to the General Arrangement drawing as necessary for component identification and location while conducting start-up and operational procedures.

Note: If your dryer cannot be started, or fails to start due to special installation or other problems, contact your local Deltech Sales Representative for assistance.

2. All Prefilter and Afterfilter Assemblies are shipped **WITH** filter cartridges installed. Verify that prefilter and afterfilter cartridges are installed. Prefilter and Afterfilter cartridges are **NOT** interchangeable and must be installed in their respective assemblies **ONLY**. The proper filter cartridge part number is listed on each Prefilter and Afterfilter Assembly.
3. Replace and tighten filter assembly bowls. Ensure that O-rings are properly seated.
4. Close any manual vent or drain valves installed in prefilter and afterfilter assemblies.
5. If the prefilter assembly was factory equipped with an automatic drain valve, inspect for, and remove pipe plug or cap which may have been installed in drain port for shipping purposes. Ensure isolation ball valve to automatic drain valve is open.
6. Ensure that all associated pipe and tubing connections, flanges, unions, plugs, mounting bolts, pipe hangers, etc., have been checked tight and/or properly secured.

IMPORTANT: It is recommended that the System's process gas output not be consumed or used at the intended points of use until the Start-Up and any related adjustments have been completed, and the system is producing process gas of the required quality. The quality of the process gas should be verified through test and analysis when a specific quality process gas is required.

7. Supply compressed air up to System Inlet Isolation Valve.
8. Open the Pilot Gas Supply Valve, located upstream of the Pilot Gas Filter.
9. Supply pressure to system by slowly opening the System Inlet Isolation Valve (customer supplied). The Inlet Switching Valve will open to either left or

right chamber. Both Purge Exhaust Switching Valves will close. The desiccant chambers will immediately begin pressurizing to system pressure as indicated by chamber pressure gauges.

10. The Moisture Indicator's (if dryer so-equipped) bleed valve is installed directly into the back of the indicator's body. Close the Indicator's Bleed Valve. FULLY open the Moisture Indicator Supply Valve.
11. Soap bubble test all external piping, fittings, and connections. Locate and repair all noted points of leakage. **Do not soap bubble test components located inside dryer control system's enclosure.**

Note: Small leaks noted in inlet piping to the dryer will not affect operation, other than a slight loss of pressure supplied to the dryer. HOWEVER, any gas leaks, (no matter how small), detected at, or downstream of the dryer outlet MUST BE FIXED to ensure that the dryer will provide a continuous supply of process gas at specified dew point, to intended points-of-use.

IMPORTANT: Water molecules can diffuse through a pinhole-size leak even though pressure inside the piping is several hundred PSIG. It is not uncommon to have a minute pinhole leak in a gas line cause an increase in dew point from -40°F to -10°F at a distance of forty or more feet downstream of the leak.
12. SLOWLY open the System Outlet Isolation Valve (customer supplied), while monitoring the Outlet Pressure Gauge (if dryer so-equipped). **DO NOT** permit the Dryer's Outlet Pressure Gauge to exceed a 5% drop in pressure while pressurizing downstream piping.
13. Close the System Bypass Valve (if gas system has been so-equipped).
14. Open and adjust the Moisture Indicator's Bleed Valve until a very slight, continuous gas bleed is felt exhausting from the bleed valve's exhaust port. Ensure that the granular indicator crystals remain motionless after final adjustment.
15. Energize the dryer's electrical power supply.
16. Refer to Appendix A (Appendix C for -100°F pdp) of this manual and calculate your dryer model's purge pressure setting as instructed.
17. Locate the Purge Adjusting Valve. Slowly rotate dryer's Purge Adjusting Valve until the Purge Pressure Indicator indicates the calculated purge pressure setting. (See following Note).

Note: The purge pressure can only be read and adjusted when an off-stream desiccant chamber has depressurized for regeneration. (When the off-stream chamber is pressurized, the Purge Pressure Indicator will read "system pressure".)

For dryers with the Hydrobloc Energy Management System: During operation in the Energy Management Mode, the off-stream chamber may remain pressurized (in ENERGY MANAGEMENT ACTIVE). If this condition is noted, proceed as follows to adjust purge pressure.

- a) Open Dryer Control System Enclosure. Locate DIP switches on MEC CPU Board.
 - b) Switch DIP switch position 7 to OFF position (down). De-energize dryer's electrical power supply for approximately fifteen (15) seconds; then re-energize. Dryer is now in Fixed Cycle Operation. The off-stream chamber will depressurize to atmosphere for regeneration.
 - c) Calculate and set purge pressure as previously instructed.
 - d) Return DIP switch position 7 to ON position. De-energize the dryer's electrical power supply for approximately fifteen (15) seconds; then re-energize. Dryer should be in Compu-Save Energy Saver Mode.
18. The Start-Up procedure for models LS1250 and LS1500 is now complete. Proceed to the Normal Operation Checks section of this manual for final operational checks and adjustments.

Dryer Models LS2070 and LS2580

Do not start the dryer with compressed air flow through the dryer. Close customer supplied dryer shut-off valves before beginning start-up procedure.

1. Refer to the General Arrangement drawing as necessary for component identification and location while conducting start-up and operational procedures.

Note: If your dryer cannot be started, or fails to start due to special installation or other problems, contact your local Deltech Sales Representative for assistance.
2. Remove the Pilot Gas Filter Bowl. Verify that the pilot gas filter cartridge is installed. Replace Filter Bowl ensuring that O-ring is properly seated. Close the filter bowl bleed valve.
3. All Prefilter and Afterfilter Assemblies are shipped **WITH** filter cartridges installed. Verify that prefilter and afterfilter cartridges are installed. Prefilter and Afterfilter cartridges are **NOT** interchangeable and must be installed in their respective assemblies **ONLY**. The proper filter cartridge part number is listed on each Prefilter and Afterfilter Assembly.
4. Replace and tighten filter assembly bowls. Ensure that O-rings are properly seated.

5. Close any manual vent or drain valves installed in prefilter and afterfilter assemblies.
6. If the prefilter assembly utilized was factory-equipped with an automatic drain valve or drain trap, inspect for, and remove pipe plug or cap which may have been installed in **drain port** for shipping purposes.
7. Ensure that all associated pipe and tubing connections, flanges, unions, plugs, mounting bolts, pipe hangers, etc., have been checked tight and/or properly secured.

IMPORTANT: It is recommended that the System's process gas output not be consumed or used at the intended points of use until the Start-Up and any related adjustments have been completed, and the system is producing process gas of the required quality. The quality of the process gas should be verified through test and analysis when a specific quality process gas is required.

8. Supply compressed air up to Inlet Isolation Valve.
9. Close the Pilot Gas Supply Valve and pressurize the pilot gas system with compressed gas to line pressure. Use the Ball Valve located in the pilot gas line prior to the Pilot Gas Filter and after the Pilot Gas Supply Valve. Both desiccant chamber Inlet Valves will open and both Purge Exhaust Valves will close.
10. Supply pressure to system by slowly opening the System Inlet Isolation Valve (customer supplied). Both Inlet Switching Valves are open. Both Purge Exhaust Switching Valves are closed (Refer to step 9). The desiccant chambers will immediately begin pressurizing to system pressure as indicated by chamber pressure gauges.
11. When both chambers are at supply pressure, open the Pilot Gas Supply Valve and disconnect the gas supply to the pilot gas system at the Start-Up Ball Valve.
12. The Moisture Indicator's (if dryer so-equipped) bleed valve is installed directly into the back of the indicator's body. Close the Indicator's Bleed Valve. FULLY open the Moisture Indicator Supply Valve.
13. Soap bubble test all external piping, fittings, and connections. Locate and repair all noted points of leakage. **Do not soap bubble test components located inside dryer control system's enclosure.**

Note: Small leaks noted in inlet piping to the dryer will not affect operation, other than a slight loss of pressure supplied to the dryer. HOWEVER, any gas leaks, (no matter how small), detected at, or downstream of the dryer outlet **MUST BE FIXED** to ensure that the dryer will provide a continuous supply of process gas at specified dew point, to intended points-of-use.

IMPORTANT: Water molecules can diffuse through a pinhole-size leak even though pressure inside the piping is several hundred PSIG. It is not uncommon to have a minute pinhole leak in a gas line cause an increase in dew point from -40°F to -10°F at a distance of forty or more feet downstream of the leak.

14. SLOWLY open the System Outlet Isolation Valve (customer supplied), while monitoring the Outlet Pressure Gauge (if dryer so-equipped). **DO NOT** permit the Dryer's Outlet Pressure Gauge to exceed a 5% drop in pressure while pressurizing downstream piping.
15. Close the System Bypass Valve (if gas system has been so-equipped).
16. Open and adjust the Moisture Indicator's Bleed Valve until a very slight, continuous gas bleed is felt exhausting from the bleed valve's exhaust port. Ensure that the granular indicator crystals remain motionless after final adjustment.
17. Energize the dryer's electrical power supply.
18. Refer to Appendix A (Appendix C for -100°F pdp) of this manual and calculate your dryer model's purge pressure setting as instructed.
19. SLOWLY rotate dryer's Purge Adjusting Valve until the Purge Pressure Indicator indicates the calculated purge pressure setting. (See following Note).

Note: The purge pressure can only be read and adjusted when an off-stream desiccant chamber has depressurized for regeneration. (When the off-stream chamber is pressurized, the Purge Pressure Indicator will read "system pressure".)

For dryers with the Hydrobloc Compu-Save Energy Management System: During operation in the Energy Management Mode, the off-stream chamber may remain pressurized (in ENERGY MANAGEMENT ACTIVE). If this condition is noted, proceed as follows to adjust purge pressure.

- a) Open Dryer Control System Enclosure. Locate DIP switches on MEC CPU Board.
- b) Switch DIP switch position 7 to OFF position (down). De-energize dryer's electrical power supply for approximately fifteen (15) seconds; then re-energize. Dryer is now in Fixed Cycle Operation. The off-stream chamber will depressurize to atmosphere for regeneration.
- c) Calculate and set purge pressure as previously instructed.
- d) Return DIP switch position 7 to ON position. De-energize the dryer's electrical power supply for approximately fifteen (15) seconds; then re-energize. Dryer should be in Compu-Save Energy Saver Mode.

- The Start-Up procedure for models LS2070 and LS2580 is now complete. Proceed to the Normal Operation Checks section of this manual for final operational checks and adjustments.

3.5 Normal Start-Up or Restart For Dryers With Fixed Cycle Electronic Timer Control (Models LS60 through LS1000 only)

- Close the Pilot Gas Filter's Bleed Valve.
- Close any manual vent or drain valves installed in prefilter and afterfilter assemblies.
- Close the System Outlet Isolation Valve (customer supplied).
- Energize the dryer's electrical power supply.

The following indicator lights will illuminate:

- POWER ON
- LEFT or RIGHT CHAMBER DRYING

Note: Should the dryer experience a power interruption during a normal cycle, the unit will return to the same status of operation that existed at the time of the power interruption.

- Supply pressure to system by slowly opening the System Inlet Isolation Valve (customer supplied). The Right Chamber Inlet Switching Valve and Left Chamber Purge Exhaust Switching Valve will close. The Left Chamber will immediately begin pressurizing to system pressure as indicated by the chamber pressure gauge.
- PARTIALLY open the System Outlet Isolation Valve (customer supplied), while monitoring the outlet pressure gauge. **Do not** permit the Dryer's Outlet Pressure gauge to exceed a 5% drop in pressure while pressurizing downstream piping.
- Close the System Bypass Valve (if gas system has been so-equipped).
- Refer to Appendix A (Appendix C for -100°F pdp) of this manual and calculate your dryer model's purge pressure setting as instructed.
- Locate the Purge Adjusting Valve. Slowly rotate dryer's Purge Adjusting Valve until the Purge Pressure Indicator indicates the calculated purge pressure setting. (See following Note).

Note: The purge pressure can only be read and adjusted when an off-line desiccant chamber has depressurized for regeneration. (When the off-line chamber is pressurized, the Purge Pressure Indicator will read "system pressure".)

- The Normal Start-Up or Restart procedure for models LS60 through LS1000 is now complete. Proceed to the Normal Operational Checks section of this manual for final operational checks and adjustments.

3.6 Normal Start-Up or Restart For Dryers With DEC Controller

Dryer Models LS60 through LS1000

- Close the Pilot Gas Filter's Bleed Valve.
- Close any manual vent or drain valves installed in prefilter and afterfilter assemblies.
- Close the System Outlet Isolation Valve (customer supplied).
- Energize the dryer's electrical power supply.
- Supply pressure to system by slowly opening the System Inlet Isolation Valve (customer supplied). Both desiccant chamber Inlet Switching Valves will open and both Purge Exhaust Switching Valves will close. The desiccant chambers will immediately begin pressurizing to system pressure as indicated by chamber pressure.
- Fully open the Moisture Indicator Supply Valve.
- The Moisture Indicator's (if dryer so-equipped) bleed valve is installed directly into the back of the indicator's body. Adjust the Moisture Indicator's Bleed Valve until a very slight, continuous gas bleed is felt exhausting from the bleed valve's exhaust port. Ensure that the granular indicator crystals remain motionless after final adjustment.
- PARTIALLY open the System Outlet Isolation Valve (customer supplied), while monitoring the outlet pressure gauge. **Do not** permit the Dryer's Outlet Pressure gauge to exceed a 5% drop in pressure while pressurizing downstream piping.
- Close the System Bypass Valve (if gas system has been so-equipped).
- Refer to Appendix A (Appendix C for -100°F pdp) of this manual and calculate your dryer model's purge pressure setting as instructed.
- Locate the Purge Adjusting Valve. Slowly rotate dryer's Purge Adjusting Valve until the Purge Pressure Indicator indicates the calculated purge pressure setting. (See following Note).

Note: The purge pressure can only be read and adjusted when an off-line desiccant chamber has depressurized for regeneration. (When the off-line

chamber is pressurized, the Purge Pressure Indicator will read "system pressure".)

12. The Normal Start-Up or Restart procedure for models LS60 through LS1000 is now complete. Proceed to the Normal Operational Checks section of this manual for final operational checks and adjustments.

Dryer Models LS1250 and LS1500

1. Close the Pilot Gas Filter's Bleed Valve.
2. Close any manual vent or drain valves installed in prefilter and afterfilter assemblies.
3. Close the System Outlet Isolation Valve (customer supplied).
4. Open the Pilot Gas Supply Valve, located upstream of the Pilot Gas Filter.
5. Supply pressure to system by slowly opening the System Inlet Isolation Valve (customer supplied). The Right Chamber Inlet Switching Valve and Left Chamber Purge Exhaust Switching Valve will close. The Left Chamber will immediately begin pressurizing to system pressure as indicated by the chamber pressure gauge.
6. Fully open the Moisture Indicator Supply Valve.
7. The Moisture Indicator's (if dryer so-equipped) bleed valve is installed directly into the back of the indicator's body. Adjust the Moisture Indicator's Bleed Valve until a very slight, continuous gas bleed is felt exhausting from the bleed valve's exhaust port. Ensure that the granular indicator crystals remain motionless after final adjustment.
8. PARTIALLY open the System Outlet Isolation Valve (customer supplied), while monitoring the outlet pressure gauge. **Do not** permit the Dryer's Outlet Pressure gauge to exceed a 5% drop in pressure while pressurizing downstream piping.
9. Close the System Bypass Valve (if gas system has been so-equipped).
10. Energize the dryer's electrical power supply.
11. Refer to Appendix A (Appendix C for -100°F pdp) of this manual and calculate your dryer model's purge pressure setting as instructed.
12. Locate the Purge Adjusting Valve. Slowly rotate dryer's Purge Adjusting Valve until the Purge Pressure Indicator indicates the calculated purge pressure setting. (See following Note).

Note: The purge pressure can only be read and adjusted when an off-line desiccant chamber has depressurized for regeneration. (When the off-line chamber is pressurized, the Purge Pressure Indicator will read "system pressure".)

13. The Normal Start-Up or Restart procedure for models LS1250 through LS1500 is now complete. Proceed to the Normal Operational Checks section of this manual for final operational checks and adjustments.

Dryer Models LS2070 and LS2580

1. Close the Pilot Gas Filter's Bleed Valve.
2. Close any manual vent or drain valves installed in prefilter and afterfilter assemblies.
3. Close the System Outlet Isolation Valve (customer supplied).
4. Close the Pilot Gas Supply Valve and pressurize the pilot gas system with compressed gas to line pressure. Use the Ball Valve located in the pilot gas line prior to the Pilot Gas Filter and after the Pilot Gas Supply Valve. Both desiccant chamber Inlet Valves will open and both Purge Exhaust Valves will close.
5. Supply pressure to system by slowly opening the System Inlet Isolation Valve (customer supplied). Both Inlet Switching Valves are open. Both Purge Exhaust Switching Valves are closed (see step 4). The desiccant chambers will immediately begin pressurizing to system pressure as indicated by chamber pressure gauges.
6. Fully open the Moisture Indicator Supply Valve.
7. The Moisture Indicator's (if dryer so-equipped) bleed valve is installed directly into the back of the indicator's body. Adjust the Moisture Indicator's Bleed Valve until a very slight, continuous gas bleed is felt exhausting from the bleed valve's exhaust port. Ensure that the granular indicator crystals remain motionless after final adjustment.
8. PARTIALLY open the System Outlet Isolation Valve (customer supplied), while monitoring the outlet pressure gauge. **Do not** permit the Dryer's Outlet Pressure gauge to exceed a 5% drop in pressure while pressurizing downstream piping.
9. Close the System Bypass Valve (if gas system has been so-equipped).
10. Energize the dryer's electrical power supply.
11. Refer to Appendix A (Appendix C for -100°F pdp) of this manual and calculate your dryer model's purge pressure setting as instructed.
12. Locate the Purge Adjusting Valve. Slowly rotate dryer's Purge Adjusting Valve until the Purge Pressure Indicator indicates the calculated purge pressure setting. (See following Note).

Note: The purge pressure can only be read and adjusted when an off-line desiccant chamber has de-

pressurized for regeneration. (When the off-line chamber is pressurized, the Purge Pressure Indicator will read "system pressure".)

13. The Normal Start-Up or Restart procedure for models LS2070 through LS2580 is now complete. Proceed to the Normal Operational Checks section of this manual for final operational checks and adjustments.

3.7 Normal Operational Checks

1. Ensure that the dryer is being operated at the correct inlet pressure, flow rate, and inlet temperature, as specified on the Dryer Specification Label (located on inside cover of dryer system control enclosure).
2. If the prefilter utilizes any automatic drain device, ensure that it is draining and functioning properly.
3. Ensure that the Purge Pressure Indicator (gauge) indicates the pressure setting calculated during start-up.
4. After an off-stream desiccant chamber has depressurized for regeneration, a flow of purge gas should be felt exiting the purge exhaust muffler. The regenerating chamber's pressure gauge **MUST** indicate zero (0) PSIG throughout the purging period.
- 5a. The dryer controller should automatically switch the system from left to right and right to left chamber drying on a fixed time cycle. If the system fails to switch drying chambers twice within its designated NEMA Cycle, refer to the TROUBLESHOOTING GUIDE.
- 5b. If a Hydrobloc Compu-Save Energy Management System Control indicates a High Humidity Warning upon start-up, it should automatically shift to **ENERGY MANAGEMENT ACTIVE** within twenty-four (24) hours of start-up. If system fails to shift to **ENERGY MANAGEMENT ACTIVE** within this time period, refer to the TROUBLESHOOTING GUIDE and conduct checks listed for **HIGH HUMIDITY WARNING** (See following Note.)

Note: The system will operate in a fixed cycle accompanied by a HIGH HUMIDITY WARNING until the desiccant beds have been regenerated to the extent necessary to provide a process gas supply at the dryer's rated dew point. The control system will then automatically shift to ENERGY MANAGEMENT ACTIVE. During normal dryer operation (ENERGY MANAGEMENT ACTIVE), the off-stream desiccant chamber will depressurize and begin regenerating (purging) **ONLY** when the need for a regeneration cycle is sensed by the chamber's Compu-Save Humidity Sensor. Otherwise, the off-stream chamber will remain pressurized.

6. If the dryer has a Moisture Indicator and the Indicator's granular indicating gel is pink at the time of dryer start-up, a color change to blue should be noted within twenty-four (24) hours. Ensure that the indicator's bleed valve has been adjusted as instructed in the start-up procedure.
7. Ensure that the System Inlet and Outlet Isolation Valves (customer supplied) have been **fully opened**.
8. Ensure that the dryer control system's enclosure cover is closed with **all** latches tightened to prevent entrance of moisture, dust, dirt, etc.
9. SHUTDOWN AND DEPRESSURIZE DRYER following two (2) to three (3) weeks of initial operation. Inspect desiccant beds through fill ports, for settling. If settling has occurred, refill chambers as necessary to bring desiccant levels to **bottom** of each desiccant retaining screen. **Do Not Tamp or Ram Desiccant.**

3.8 Dryer Shutdown

1. De-energize the dryer's electrical supply. When the dryer's power supply is de-energized, both desiccant chambers will be automatically placed on-stream.
2. Close the System Outlet Isolation Valve (customer supplied).
3. Close the System Inlet Isolation Valve (customer supplied).

IMPORTANT: Inlet **and** Outlet Isolation Valves **MUST** be closed to prevent moisture overloading of desiccant beds, due to continuous flow without regeneration.

4. Close the Moisture Indicator Supply Valve (if dryer has been so-equipped). This **MUST** be done to prevent depressurization of the pilot gas supply, which in turn, will eventually result in dryer depressurization.
5. Shutdown is now complete. The dryer may be left pressurized during periods of non-use, if desired. However, if any servicing or maintenance is to be performed, ensure that the dryer is depressurized **BEFORE** beginning work. Proceed to Step 6 for depressurization instructions.

WARNING!

Ensure that the system is de-energized, valve isolated, and fully depressurized before attempting to remove or disassemble any component or subassembly. Failure to do so may result in serious personal injury and/or equipment damage.

6. To depressurize dryer, proceed as follows:
 - a) Open customer-supplied System Bypass Valve (if gas system has been so-equipped).

- b) Close the Pilot Gas Supply Valve.
- c) Open the Pilot Gas Filter's Bleed Valve. Allow pilot gas system to depressurize through the Pilot Gas Filter's Bleed Valve. When pilot gas pressure is sufficiently reduced, the Purge Exhaust Switching Valves will automatically open to depressurize dryer through Purge Exhaust Muffler.
- d) SLOWLY open customer supplied depressurization valve to vent the dryer internal air pressure.
- e) When all dryer pressure gauges indicate zero pressure, close the depressurization valve. Depressurization is complete.

4

Maintenance and Repair

4.1 Preventative Maintenance Schedule

Weekly

1. Check the following operating conditions:
 - a) Purge pressure setting (during regeneration)
 - b) Inlet pressure
 - c) Inlet flow rate
 - d) Inlet temperature

For optimum dryer operation and performance, these recorded parameters should correspond as close as is possible to the design operating conditions and specifications noted on the Dryer Specification Label (located on inside cover of dryer control enclosure).

2. Visually inspect the Moisture Indicator (if dryer is so-equipped) for a BLUE (dry) indication. If the indicator is PINK (wet) in color, refer to the Troubleshooting Guide and conduct checks listed for the Moisture Indicator.
3. Check the dryer's Indicator Panel for the presence of any illuminated alarm indicators. If an alarm indicator is illuminated, refer to the Troubleshooting Guide.
4. Check the pressure drop (differential pressure) across the Prefilters and Afterfilters. Prefilter and afterfilter cartridges should be replaced BEFORE a differential pressure of 10 PSID is exceeded.

CAUTION: Each component of a Deltech Regenerative Desiccant Dryer System has been selected to compliment the performance of the other components of the system. Therefore, use of unauthorized parts or supplies or improper operation will degrade system performance.

5. Check operation of the prefilter's automatic drain valve. This component must function properly to maintain filter efficiency and prevent premature desiccant failure induced by liquid and oil carry over from the prefilter, due to a clogged or inoperative automatic drain valve.

Quarterly

Check the dry gas outlet dew point. A precision Dew Point Analyzer is required to read the exact dew point. The analyzer should be connected as close to the dryer outlet as is possible. Test piping or tubing used to connect the analyzer to the gas system must be metallic, as rubber and certain plastics contain or permit moisture diffusion from the ambient air and can cause a false high dew point indication. Alnor, Beckman, Shaw and several other brands of precision dew point instruments are available.

Semi-Annually

WARNING!

Ensure that the Dryer and any associated Prefilters and Afterfilters are valve isolated and fully depressurized before attempting to remove or disassemble any components or subassemblies. Failure to do so may result in serious personal injury and/or equipment damage.

CAUTION: Each component of a Deltech Regenerative Desiccant Dryer System has been selected to compliment the performance of the other components of the system. Therefore, use of unauthorized parts or supplies or improper operation will degrade system performance.

1. Inspect the Pilot Gas Filter Cartridge and replace if the used cartridge appears clogged, dirty or excessively corroded.
2. Inspect the Prefilter Cartridges for clogging, excessive corrosion, cracked or damaged end seals or high pressure drop (differential pressure exceeds 10 PSID). Replace cartridges if necessary.
3. Inspect the Afterfilter Cartridges for clogging, excessive corrosion, cracked or damaged end seals or high pressure drop (differential pressure exceeds 10 PSID). Replace cartridges if necessary.

Annually

WARNING!

Ensure that the Dryer and any associated Prefilters and Afterfilters are valve isolated and fully depressurized before attempting to remove or disassemble any components or subassemblies. Failure to do so may result in serious personal injury and/or equipment damage.

1. Disassemble, clean and inspect the Outlet and Purge Check Valve Assemblies. Replace all damaged or worn parts.
2. Disassemble, clean and inspect the Inlet Switching and Purge Exhaust Switching Valves. Replace all damaged or worn parts.
3. Remove the desiccant fill port plugs or drain port flanges from the top of each desiccant chamber. Visually inspect the desiccant through each chamber's fill port. Replace desiccant if it appears badly broken or contaminated with oil.

4.2 Desiccant Charging Procedures

Note: Periodic desiccant replacement is necessary to maintain dryer performance. The frequency of desiccant replacement is dependent on the actual operating conditions present, and will vary in all cases. These conditions can be process related, mechanical or accidental. A rising dew point at the dryer outlet is an indication that new desiccant is required. This is assuming that the dryer is functioning properly from a mechanical and control standpoint; and the dryer is not being overloaded (operated above its maximum flow capacity).

Desiccant is normally installed prior to shipment unless otherwise specified by the customer. Tapping on each desiccant chamber with a soft-face mallet will yield a deadened sound if desiccant has been installed. If a hollow sound is noted, the chambers are empty and require installation of desiccant before operation.

WARNING!

Ensure that the Dryer is de-energized, valve isolated and fully depressurized before attempting to remove or disassemble any Dryer component or subassembly. Failure to do so may result in serious personal injury and/or equipment damage.

CAUTION: Dryer models covered within the scope of this manual are designed to use a specific desiccant. Use of any other size or type may reduce efficiency or damage the Dryer.

CAUTION: Prior to installing desiccant, review all applicable Material Safety Data Sheets and container warnings. Safety Data Sheets may be obtained from the manufacturers Safety Coordinator. Exercise all necessary precautions for your health and welfare.

WARNING!

A static electric charge can build up when pouring desiccants or dry powders. Proper grounding should be observed when pouring from a container (bag, drum, etc.).

WARNING!

Do not transfer desiccant under pressure. Malfunction or improper use of equipment can propel beads with enough velocity to penetrate skin.

WARNING!

Used desiccant material must be handled with special care. Desiccant is an adsorbent material. Used desiccant may contain chemicals and/or gases that are hazardous, toxic and/or flammable. It is recommended that all used desiccant be analyzed to determine content before disposal. Exercise proper care and procedures during handling and storage of used materials. All containers must be properly labelled and disposed of in accordance with Local, State and Federal regulations.

1. Remove the desiccant fill port plug or drain port flange installed in the top of each desiccant chamber. Clean and inspect the fill port closure.

Note: If this is an Initial Desiccant Installation Procedure go to Procedure 8.

2. Place a container suitable for receiving the spent desiccant under the desiccant chambers.
3. Remove desiccant drain port plug or drain port flange from the bottom of each desiccant chamber. When the drain port plug or drain port flange is removed, the desiccant will begin draining.
4. Use a flashlight to inspect each chamber through its respective fill port to ensure that all desiccant has been drained. LIGHT tapping on the chamber sides with a soft-face mallet will remove any desiccant that may have remained in each chamber.
5. Use a wire brush to clean drain ports and drain port plug threads.
6. Apply TFE tape to drain port plug threads. Reinstall drain port plugs or drain port flanges into each drain port. Torque drain port plugs or flange bolts to a reasonable limit.
7. Refer to Table 4.1 for the quantity of desiccant and tabular support required for each desiccant chamber.
8. Utilizing an appropriately sized funnel, fill each desiccant chamber as follows:

**Table 4.1
DESICCANT REQUIREMENTS**

Model	Activated Alumina (lbs. per chamber)	
	OPD-4	OPD-25
LS60	24	—
LS110	42	—
LS130	72	—
LS185	72	—
LS240	92	—
LS270	145	—
LS360	145	—
LS505	192	—
LS630	239	—
LS760	318	—
LS1000	416	—
LS1250	540	—
LS1500	675	—
LS2070	875	75
LS2580	1350	150

For Dryer Models LS60 through LS1500

- a) Fill each chamber with OPD-4 (4mm bead) desiccant until the specified quantity has been installed. Light tapping on the chamber sides with a soft-face mallet should yield additional free space to allow installation of the specified quantity. **DO NOT TAMP OR RAM DESICCANT.**

For Dryer Models LS2070 and LS2580

- a) Install the specified quantity of OPD-25 (1/4" bead) desiccant.
- b) Level layer of OPD-25.
- c) Finish filling each chamber with OPD-4 (4mm bead) desiccant until the specified quantity has been installed. Light tapping on the chamber sides with a soft-face mallet should yield additional free space to allow installation of the specified quantity. **Do Not Tamp Or Ram Desiccant.**

Note: Do not be alarmed if the specified quantity of desiccant cannot be installed in each chamber. Desiccant levels will settle after approximately two to three weeks of normal operation. Following this "settling" period, desiccant should be added as necessary to return levels to BOTTOM of each chamber's retaining screen (when installed).

9. Clean the fill port, fill port plug threads, or fill port flanges on each desiccant chamber. Apply TFE tape to fill port plug threads. Re-install the fill port plug or fill port flange in each desiccant chamber, and torque drain port plugs or flange bolts to a reasonable limit.

4.3 Filter Element Replacement

Coalescing prefilters and particulate afterfilters are included with all Hydrobloc LS Series Dryers. The filter elements should be replaced when the differential pressure gauge on top of the filter reads 7 to 10 psid, or once a year, whichever comes first. Refer to Appendix B for the replacement element part numbers. Replace elements in accordance with the following instructions.

Dryer Models LS60 through LS1250

WARNING!

Ensure that the Dryer and any associated Prefilters and Afterfilters are valve isolated and fully depressurized before attempting to remove or disassemble any components or subassemblies. Failure to do so may result in serious personal injury and/or equipment damage.

1. Isolate the filter by opening the system bypass valve (refer to Figure 2.1, page 2-2), and closing both inlet and outlet isolation valves.
2. Open the service valve to vent the filter to atmospheric pressure.
3. Disconnect drain lines at manual and automatic drain valves (if installed).

WARNING!

A "hissing" sound while the bowl is being removed indicates the filter has not been properly depressurized. DO NOT continue to remove the bowl until the filter has been completely vented to atmospheric pressure.

CAUTION: Filter bowls may be heavy. Caution should be taken when removing the bowl.

4. Remove the bottom bowl by unscrewing it from the head. A strap wrench may be needed.
5. Remove the element from the filter head with a brisk downward pull, or by working the element back and forth until it snap frees. Discard the element in accordance with applicable regulations. Used elements typically hold contaminants such as compressor lubricants and particulate matter.

Note: The element may be unsnapped by differential pressure in normal operation. This will not affect filtration, as the O-ring on the element maintains a positive seal.

6. Clean accumulated debris from the bowl with soap and water, and dry thoroughly.
7. LIGHTLY lubricate the new O-ring with a petroleum-based lubricant that is compatible with your application before installing the new element.
8. Insert new element, snapping it into place with a firm push up into the head. The element will hang from the head until the bowl is installed.
9. LIGHTLY lubricate the housing O-ring with a petroleum-based lubricant that is compatible with your application.

CAUTION: Do not use a pipe wrench to tighten the filter bowl to the head.

10. Reattach bowl to head and hand tighten. As the bowl is threaded onto the head, supports in the bottom of the bowl ensure a proper seal between the element and the filter head.
11. Reattach drain lines (if applicable).
12. Close service valve.
13. Slowly open the inlet isolation valve to prevent a pressure surge through the filter.
14. Once the filter has been pressurized, slowly open the outlet isolation valve.
15. After both isolation valves have been opened, close the system bypass valve. The filter is now in service.
16. Record the date of the element change in a record book or on the provided "Element Change" label. A new element change label with the updated information should be applied over the previous label each time the element is replaced.

Dryer Models LS1500 through LS2580

WARNING!

Ensure that the Dryer and any associated Prefilters and Afterfilters are valve isolated and fully depressurized before attempting to remove or disassemble any components or subassemblies. Failure to do so may result in serious personal injury and/or equipment damage.

1. Isolate the filter by opening the system bypass valve (refer to Figure 2.1, page 2-2), and closing both inlet and outlet isolation valves.
2. Open the service valve to vent the filter to atmospheric pressure.
3. Disconnect drain lines at manual and automatic drain valves (if installed).
4. Remove the bolts securing the filter cover to the vessel.

5. Remove the filter cover.
6. Unscrew and remove cartridge retaining seal nuts.
7. Remove the used element cartridges. Discard the cartridges in accordance with applicable regulations. Used elements typically hold contaminants, such as compressor lubricants and particulate matter.
8. Insert new element cartridges in filter.
9. Reinstall element seal nuts. Screw seal nuts on until "hand-tight", then tighten an additional one-half (1/2) turn.
10. Replace filter cover.
11. Reinstall bolts to secure filter cover.
12. Reattach drain lines (if applicable).
13. Close service valve.
14. Slowly open the inlet isolation valve to prevent a pressure surge through the filter.
15. Once the filter has been pressurized, slowly open the outlet isolation valve.
16. After both isolation valves have been opened, close the system bypass valve. The filter is now in service.
17. Record the date of the element change in a record book or on the provided "Element Change" label. A new element change label with the updated information should be applied over the previous label each time the element is replaced.

4.4 Servicing The Internal Float Drain Valve (If Equipped)

WARNING!

Ensure that the Dryer and any associated Prefilters and Afterfilters are valve isolated and fully depressurized before attempting to remove or disassemble any components or subassemblies. Failure to do so may result in serious personal injury and/or equipment damage.

1. Isolate the filter by opening the system bypass valve (refer to Figure 2.1, page 2-2), and closing both inlet and outlet isolation valves.
2. Open the service valve to vent the filter to atmospheric pressure.
3. Disconnect drain lines and automatic drain valves (if installed).

WARNING!

A "hissing" sound while the bowl is being removed indicates the filter has not been properly depressurized.

ized. **DO NOT** continue to remove the bowl until the filter has been completely vented to atmospheric pressure.

CAUTION: Filter bowls may be heavy. Caution should be taken when removing the bowl.

4. Remove the bottom bowl by unscrewing it from the head. A strap wrench may be needed.
5. Remove the nut from the bottom of the bowl.
6. Turn the bowl upside down.
7. Inspect the drain for damage. Replace if necessary or clean with a mild soap and water. Do not use solvents to clean the drain valve as they may damage the valve.
8. Hold the bowl upright and drop in the new or cleaned drain so that the drain stem is through hole at the bottom of the filter.
9. Replace the nut and hand tighten.

CAUTION: Do not use a pipe wrench to tighten the filter bowl to the head.
10. Reattach bowl to head and hand tighten.
11. Reattach drain lines (if applicable).
12. Close service valve.

13. Slowly open the inlet isolation valve to prevent a pressure surge through the filter.
14. Once the filter has been pressurized, slowly open the outlet isolation valve.
15. After both isolation valves have been opened, close the system bypass valve. The filter is now in service.

4.5 Automatic Drain Valve Disassembly and Servicing

Dryer models LS185 and larger have a timer controlled automatic drain valve.

CAUTION: Do not disassemble the drain valve timer or attempt to repair electrical parts. Replace timer if defective.

The automatic drain valve discharges condensate through a full-port drain opening. The valve body may need to be cleaned under conditions of gross particulate contamination.

To disassemble the automatic drain valve body for cleaning or other maintenance (refer to Figure 4.1):

1. Disconnect main power supply to dryer.
2. Lock out and tag power supply in accordance with OSHA requirements.

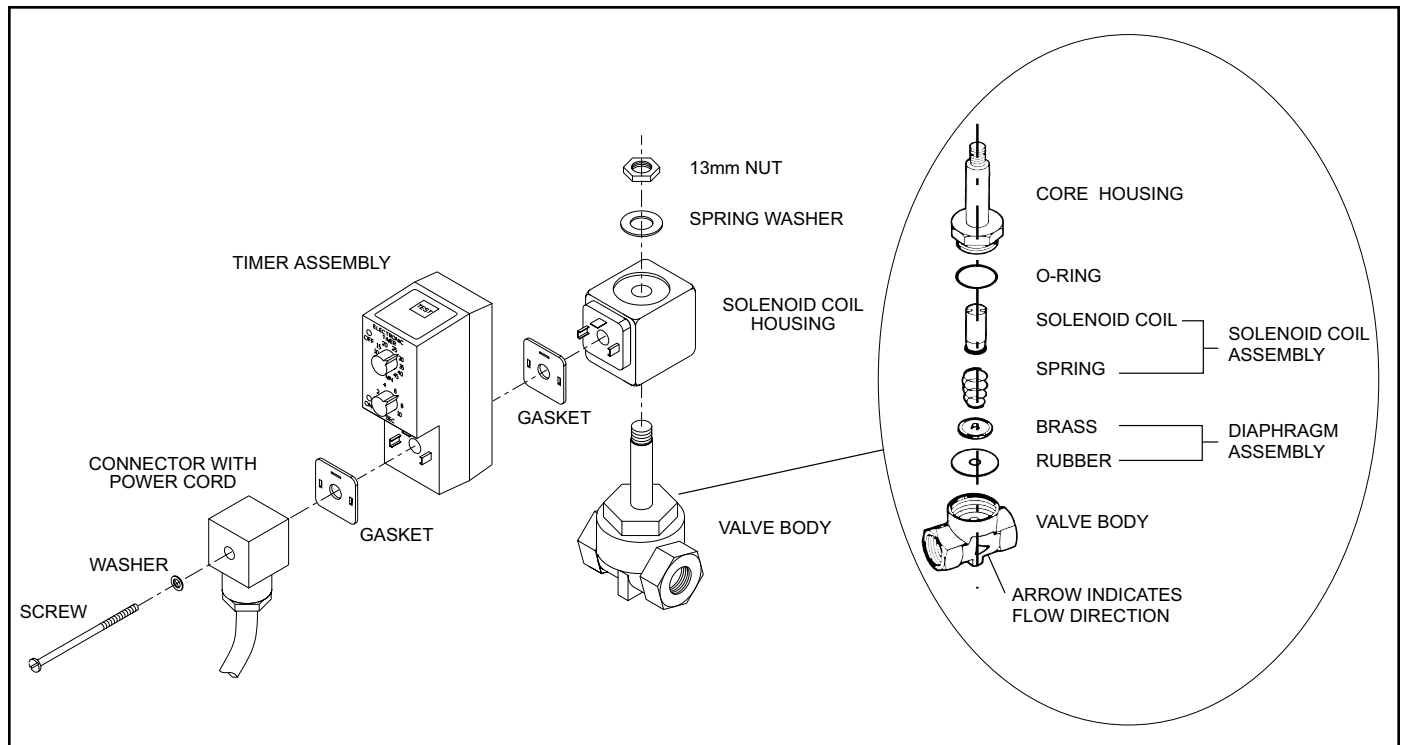

Figure 4.1
AUTOMATIC DRAIN VALVE COMPONENTS

WARNING!

Ensure that the Dryer is de-energized, valve isolated, and fully depressurized before attempting to remove or disassemble any Dryer component or subassembly. Failure to do so may result in serious personal injury and/or equipment damage.

3. Remove hose that connects the drain valve to the filter.
4. Remove screw and washer from front of drain valve.
5. Remove the power supply connector and gasket (with the timer assembly, if attached) from the solenoid coil housing. Do not damage or lose the gasket.
6. Remove 13 mm nut and spring washer from top of solenoid coil housing.
7. Lift solenoid coil housing off solenoid core in valve body.
8. Unscrew solenoid core from valve body.

Once the drain valve is disassembled, the following maintenance can be performed:

1. Inspect diaphragm, clean or replace as required.
2. Remove debris from the valve body.
3. Wipe solenoid core components with a clean cloth or blow out debris with compressed air from an OSHA approved air nozzle that limits the discharge pressure to 30 psig.
4. Check the small port in diaphragm assembly is clear and solenoid coil moves freely in housing. Viton diaphragm seals are compatible with commonly used synthetic lubricants.
5. If timer is attached to valve body, check electrical continuity across timer assembly.

4.6 Moisture Indicator Recharging Procedure

Note: Dryer shutdown is not necessary to perform the following procedure and can be accomplished without removing the entire assembly.

1. Close the Moisture Indicator Supply Valve, and ensure that the Moisture Indicator has fully depressurized through bleed valve [5] before proceeding to step #2 for disassembly. (See following WARNING.)

WARNING!

Ensure that Moisture Indicator is fully depressurized before attempting disassembly. Failure to do so may result in serious personal injury and/or equipment damage.

2. Remove sight dome assembly (items [2], [4], [6], [7], and [9]) from body [8] by turning screw [6] counter-clockwise.
3. Remove screw [6] from sight dome [2] by exerting pressure on screw's threaded end. Drain granular indicator.

4. Remove porous disc [4] and clean sight dome. (see following CAUTION.)

CAUTION: Sight Dome [2] is an acrylic plastic. **Do Not** clean with any type of solvent.

5. Replace O-ring [9], and re-install screw [6] in sight dome [2].
6. Carefully pour new granular indicator into sight dome [2]. Slide porous disc [4] into place.
7. Replace O-ring [7] and re-install sight dome assembly (items [2], [4], [6], [7], and [9]) in body [8].
8. Fully open the moisture indicator's gas supply valve (not shown).
9. Adjust bleed valve [5] until only a very slight constant gas bleed valve is felt exhausting from valve's bleed port. Ensure that granular indicator remains motionless after final adjustment.

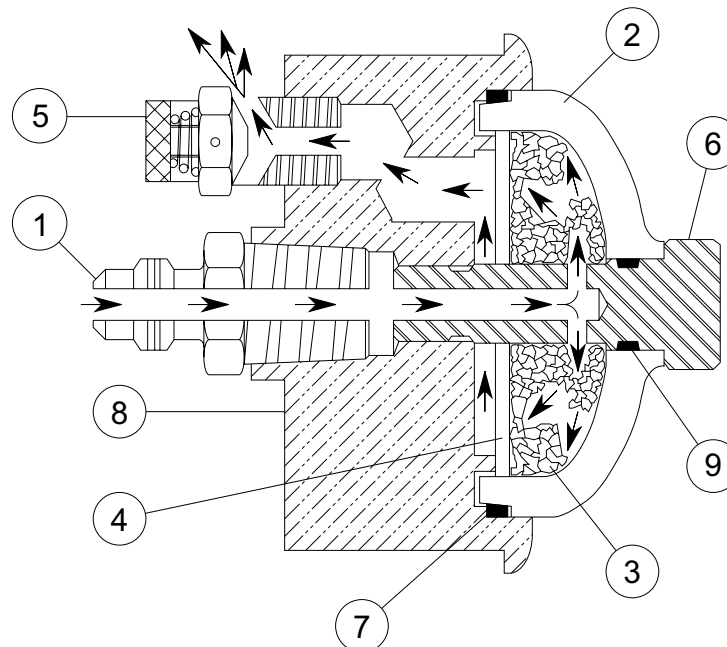

Figure 4.2
MOISTURE INDICATOR

4.7 Inlet and Purge Exhaust Switching Valve Maintenance (LS60 through LS760)

WARNING!

Ensure that the Dryer is de-energized, valve isolated, and fully depressurized before attempting to remove or disassemble any Dryer component or subassembly. Failure to do so may result in serious personal injury and/or equipment damage.

1. Clean and inspect all valve hardware upon disassembly. Replace locknuts [13] and [16] and compression springs [2] and [3]. Replace all software and any hardware which appears damaged or abnormally worn.

Note: Locknuts [13] and [16] are not re-usable. Once removed they **MUST** be replaced.

2. Clean and inspect valve seat located inside the valve body [8].
3. Apply an ultra-thin film of O-ring lubricant to items [10], [11], [15], and [23] before reassembly.
4. The U-cup piston seal [23] has been fitted with a cut O-ring. Ensure that the U-cup piston seal is installed on the valve pistons [21] and [22] as shown in Figure 4.3.
5. Apply a light coat of lubricant to sockethead cap screw, item (4). Hand tighten screws until snug. Torque as follows:

Torque 1/4 - 20 screws to 40 in-lbs.

Torque 5/16 - 18 screws to 135 in-lbs.

Switching Valve Components		
Item	Description	Total
1	Machine Screw	4
2	Compression Spring (Purge Exhaust)	2
3	Compression Spring (Inlet)	2
4	Sockethead Cap Screw	12
5	Washer	2
6	Washer	2
7	Washer	2
8	Valve Body	1
9	Flange Cover	2
10	O-Ring (Valve Cover)	4
11	O-Ring (Shaft)	2
12	Rod Scraper	2
13	Locknut	2
14	Tetraseal	3
15	O-Ring (Inlet)	4
16	Locknut	2
17	Valve Cover	2
18	Valve Poppet (Purge Exhaust)	2
19	Connect Rod (Purge Exhaust)	1
20	Connect Rod (Inlet)	1
21	Valve Piston (Purge Exhaust)	2
22	Valve Piston (Inlet)	2
23	Piston Seal	8

Piston seal [23] orientation on inlet valve piston [22]. Typical both sides.

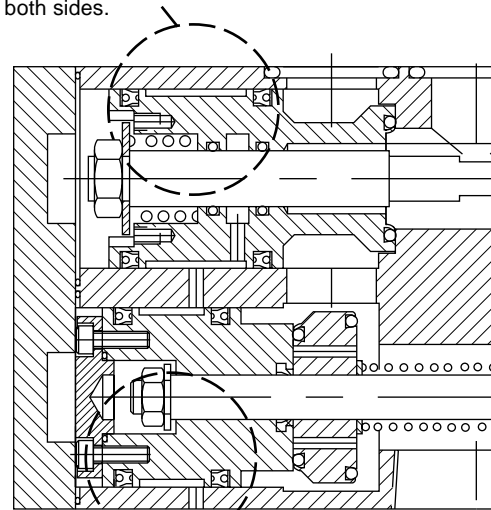

Piston seal [23] orientation on purge exhaust valve piston [21]. Typical both sides.

Figure 4.3

NOTE:

1. When the unit is located in a corrosive environment, coat sockethead cap screws with a corrosion resistant compound.

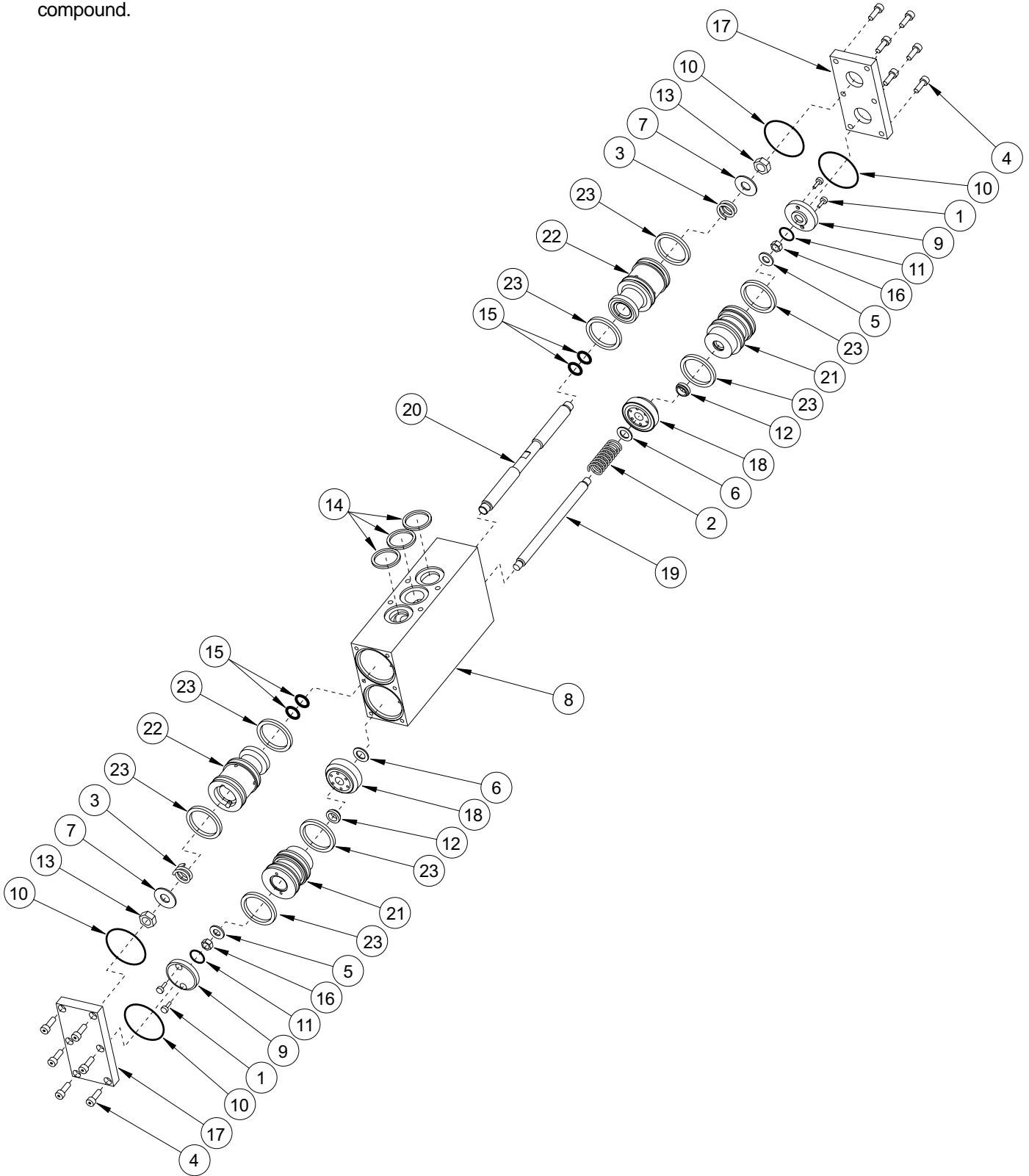

Figure 4.4
INLET AND PURGE EXHAUST SWITCHING VALVE
(LS60, LS110, LS130, LS185, LS240, LS270, LS360, LS505, LS630, LS760)

4.8 Inlet and Purge Exhaust Switching Valve Maintenance (LS1000)

WARNING!

Ensure that the Dryer is de-energized, valve isolated, and fully depressurized before attempting to remove or disassemble any Dryer component or subassembly. Failure to do so may result in serious personal injury and/or equipment damage.

1. Clean and inspect all valve hardware upon disassembly. Replace all software and any hardware which appears damaged or abnormally worn.
2. Clean and inspect valve seat located inside the valve body [1].
3. Apply an ultra-thin film of O-ring lubricant to items [14], [16], [17], and [21] before reassembly.
4. The U-cup piston seal [16] has been fitted with a cut O-ring. Ensure that the U-cup piston seal is installed on the valve pistons [4] and [5] as shown in Figure 4.3.
5. Apply a light coat of lubricant to the sockethead cap screws, items (1) and (18). Hand tighten screws until snug. Torque as follows:

Torque 1/4 - 20 screws to 40 in-lbs.

Torque 5/16 - 18 screws to 135 in-lbs.

Switching Valve Components		
Item	Description	Total
1	Valve Body	1
2	Valve Cover (Left Side)	1
3	Valve Cover (Right Side)	1
4	Valve Piston (Inlet)	2
5	Valve Piston (Purge Exhaust)	2
6	Valve Poppet (Purge Exhaust)	2
7	Connect Rod	1
8	Centering Rod	1
9	Spacer	1
10	Backup Ring	2
11	Compression Spring (Inlet)	2
12	Compression Spring (Purge Exhaust)	2
13	Washer	2
14	O-Ring (Valve Cover)	4
15	Tetraseal	3
16	Piston Seal	8
17	O-Ring (Inlet)	4
18	Sockethead Cap Screw	12
19	Locknut	2
20	Shaft	2
21	O-Ring (Shaft)	2
22	Pin	2

Piston seal [16] orientation
on inlet valve piston [4].
Typical both sides.

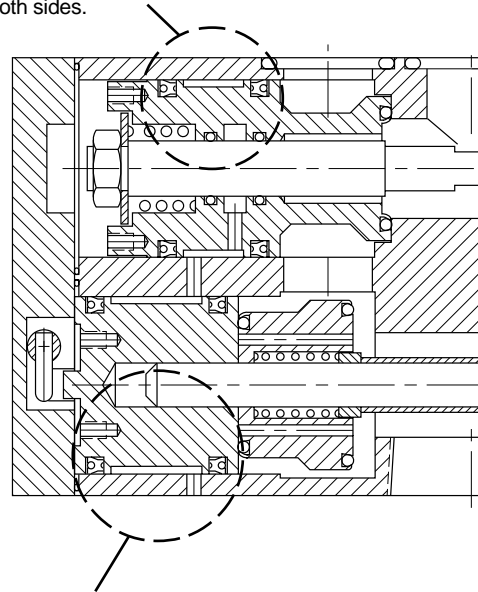

Piston seal [16] orientation
on purge exhaust valve piston [5].
Typical both sides.

Figure 4.5

NOTE:

1. When the unit is located in a corrosive environment, coat sockethead cap screws with a corrosion resistant compound.

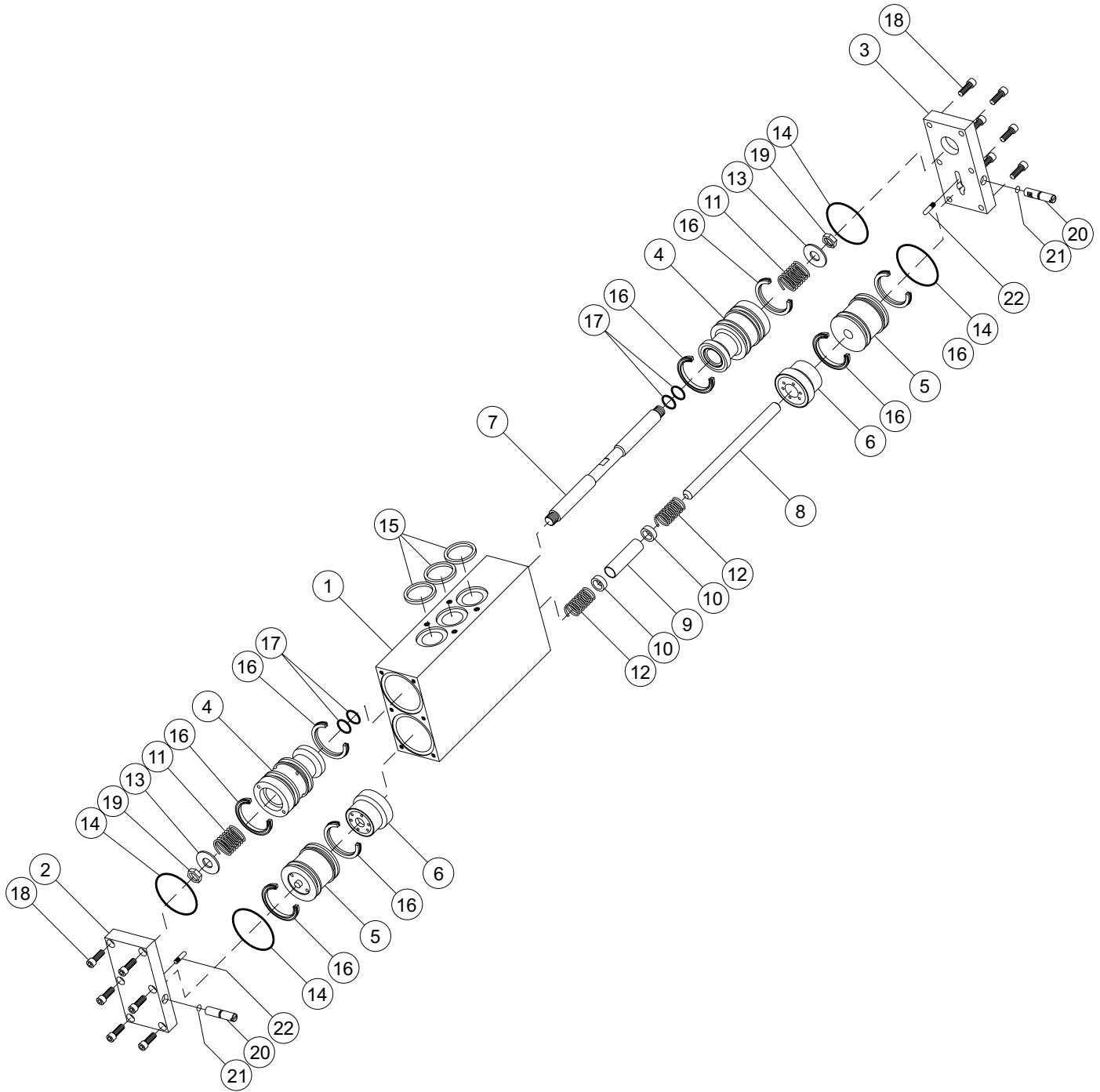

Figure 4.6
INLET AND PURGE EXHAUST SWITCHING VALVE
(LS1000)

4.9 3" Inlet Switching Valve Maintenance

(Models LS1250 and LS1500)

WARNING!

Ensure that the dryer is de-energized, valve isolated, and fully depressurized before attempting to remove or disassemble any dryer component or subassembly. Failure to do so may result in serious personal injury and/or equipment damage.

Note: Removal of valve body [21] from the dryer manifold is not required unless replacement of O-rings [23] or valve body is necessary.

1. Clean and inspect all valve hardware upon disassembly. Replace all software and any hardware which appears damaged or abnormally worn.
2. Clean and inspect valve seat located inside the valve body [21]. As previously noted, this can be accomplished without removing the valve body [9] from the dryer manifold.
3. Apply an ultra-thin film of O-ring lubricant to items [3], [6], [8], [12], [14] and [23] before reassembly.
4. Apply a light coat of lubricant to the sockethead cap screws, items (1), (20) and (22). Hand tighten screws until snug. Torque items (1) and (20) to 20 ft-lbs, and item (22) to 45 ft-lbs.

3" Switching Valve Components		
Item	Description	Total
1	Sockethead Cap Screw	4
2	Valve Cover	1
3	O-Ring	1
4	Bonnet Cylinder	1
5	Locknut	1
6	Piston Seal	1
7	Valve Piston	1
8	O-Ring	3
9	Poppet Shaft	1
10	Rod Seal	4
11	Guide Sleeve	2
12	O-Ring	1
13	Valve Bonnet	1
14	O-Ring	2
15	Rod Scraper	2
16	Valve Poppet	2
17	Poppet Shaft	1
18	Poppet Shaft	1
19	Valve Bonnet	1
20	Sockethead Cap Screw	4
21	Valve Body	1
22	Sockethead Cap Screw	4
23	O-Ring	2

NOTE:

1. When the unit is located in a corrosive environment, coat sockethead cap screws with a corrosion resistant compound.

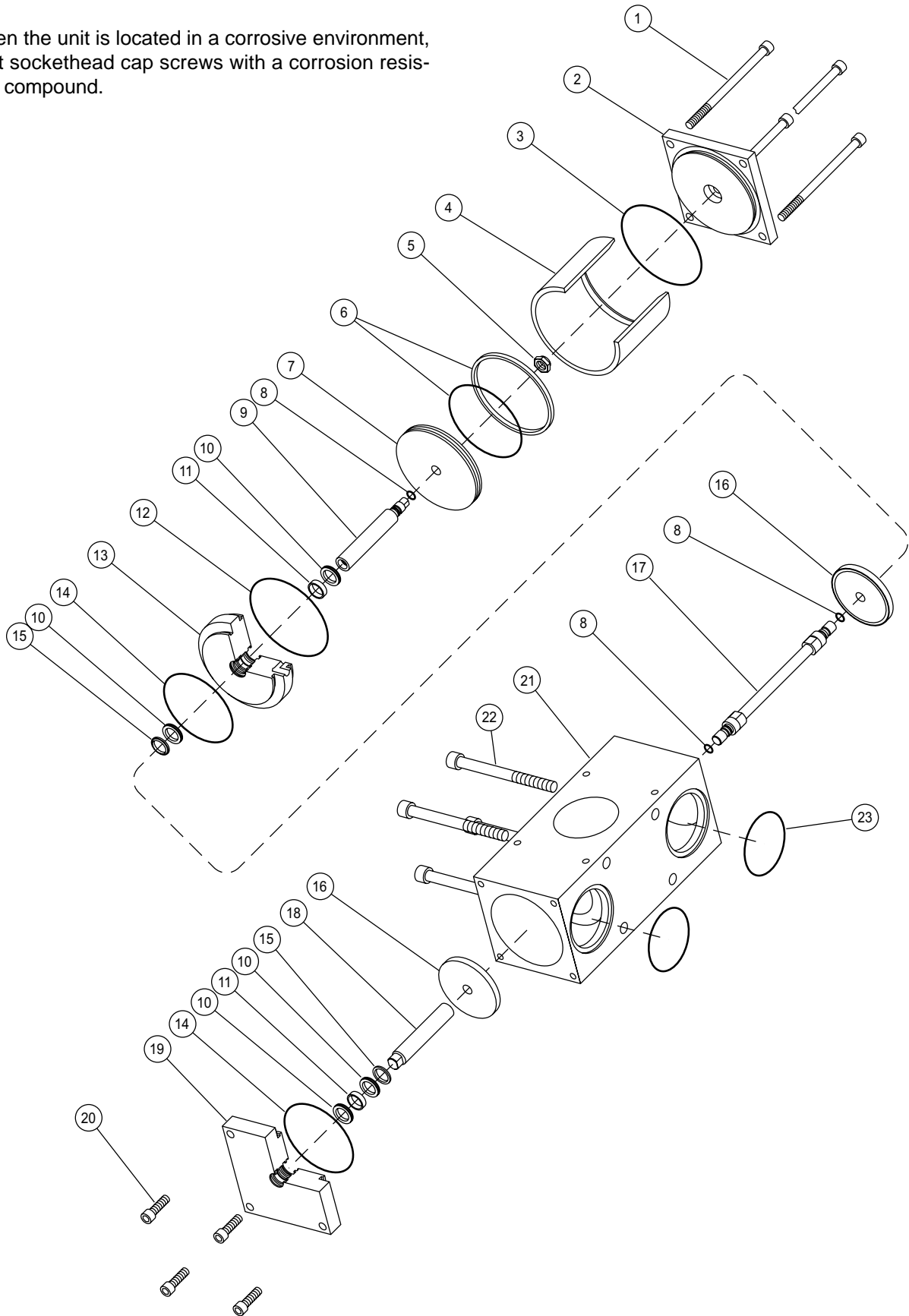

Figure 4.7
3" INLET SWITCHING VALVE
(LS1250, LS1500)

4.10 2" Purge Exhaust Switching Valve Maintenance

(Model LS1250 only)

WARNING!

Ensure that the Dryer is de-energized, valve isolated, and fully depressurized before attempting to remove or disassemble any Dryer component or subassembly. Failure to do so may result in serious personal injury and/or equipment damage.

Note: Removal of valve body [16] from the dryer manifold is not required unless replacement of square O-rings [17] or valve body is necessary.

Note: Exploded view illustrates one-half of switching valve only. Disassembly of opposite half (not shown exploded), is identical.

1. Clean and inspect all valve hardware upon disassembly. Replace all software and any hardware which appears damaged or abnormally worn.
2. Clean and inspect valve seat located inside the valve body [16]. As previously noted, this can be accomplished without removing the valve body [16] from the dryer manifold.
3. Apply an ultra-thin film of O-ring lubricant to items [3], [5], [8], [11], and [17] before reassembly. **Do not apply lubricant to the valve seat seal [13].**
4. The U-cup piston seal [5] has been fitted with a cut O-ring. Ensure that the U-cup piston seal is installed on the valve piston [4] as shown. The open side of the U-cup piston seal [5] must face the valve cover [2] upon reassembly.
5. Apply a light coat of lubricant to the sockethead cap screws, items (1) and (18). Hand tighten screws until snug. Torque to 245 in-lbs.

2" Switching Valve Components		
Item	Description	Total
1	Sockethead Cap Screw	8
2	Valve Cover	2
3	O-Ring	4
4	Valve Piston	2
5	Piston Seal	2
6	Bonnet Cylinder	2
7	Valve Bonnet	2
8	O-Ring	2
9	Rod Scraper	2
10	Poppet Shaft	2
11	O-Ring	2
12	Seal Retainer	2
13	Valve Seat Seal	2
14	Retaining Disc	2
15	Seal Nut	2
16	Valve Body	1
17	Square O-Ring	2
18	Sockethead Cap Screw	4

NOTE:

1. When the unit is located in a corrosive environment, coat sockethead cap screws with a corrosion resistant compound.

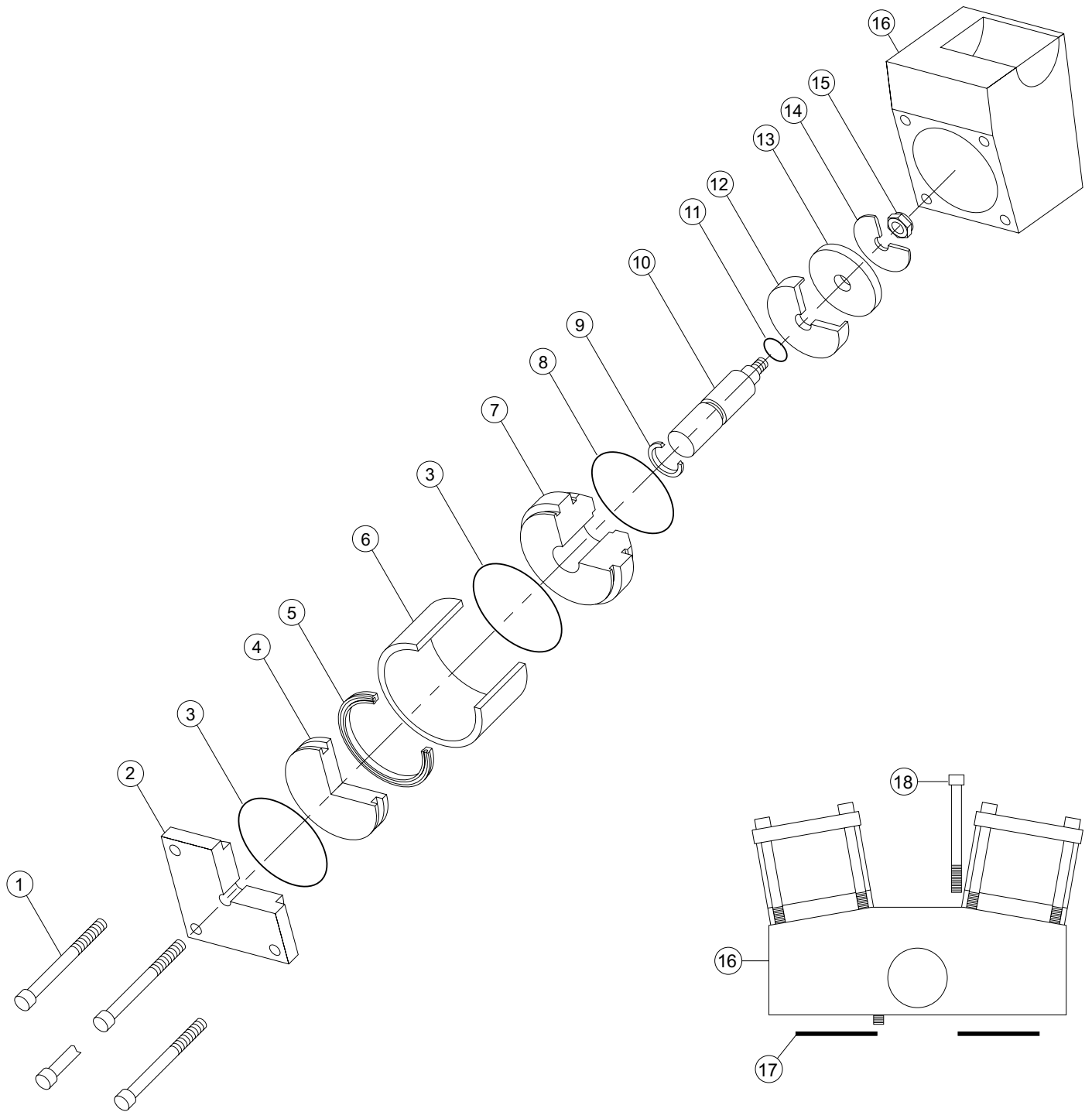

Figure 4.8
2" PURGE EXHAUST
(LS1250)

4.11 3" Purge Exhaust Switching Valve Maintenance

(Model LS1500 only)

WARNING!

Ensure that the dryer is de-energized, valve isolated, and fully depressurized before attempting to remove or disassemble any dryer component or subassembly. Failure to do so may result in serious personal injury and/or equipment damage.

Note: Removal of valve body [18] from the dryer manifold is not required unless replacement of O-rings [19] or valve body is necessary.

Note: Exploded view illustrates one-half of exhaust switching valve only. Disassembly of opposite half (not shown exploded), is identical.

1. Clean and inspect all valve hardware upon disassembly. Replace all software and any hardware which appears damaged or abnormally worn.
2. Clean and inspect valve seat located inside the valve body [18]. As previously noted, this can be accomplished without removing the valve body [18] from the dryer manifold.
3. Apply an ultra-thin film of O-ring lubricant to items [3], [6], [8], [12], [14] and [19] before reassembly.
4. Apply a light coat of lubricant to the sockethead cap screws, items (1) and (20). Hand tighten screws until snug. Torque item (1) to 20 ft-lbs, and item (20) to 45 ft-lbs.

3" Switching Valve Components		
Item	Description	Total
1	Sockethead Cap Screw	8
2	Valve Cover	2
3	O-Ring	2
4	Bonnet Cylinder	2
5	Locknut	2
6	Piston Seal	2
7	Valve Piston	2
8	O-Ring	4
9	Poppet Shaft	2
10	Rod Seal	4
11	Guide Sleeve	2
12	O-Ring	2
13	Valve Bonnet	2
14	O-Ring	2
15	Rod Scraper	2
16	Valve Poppet	2
17	Machined Bolt	2
18	Valve Body	1
19	O-Ring	2
20	Sockethead Cap Screw	4

NOTE:

1. When the unit is located in a corrosive environment, coat sockethead cap screws with a corrosion resistant compound.

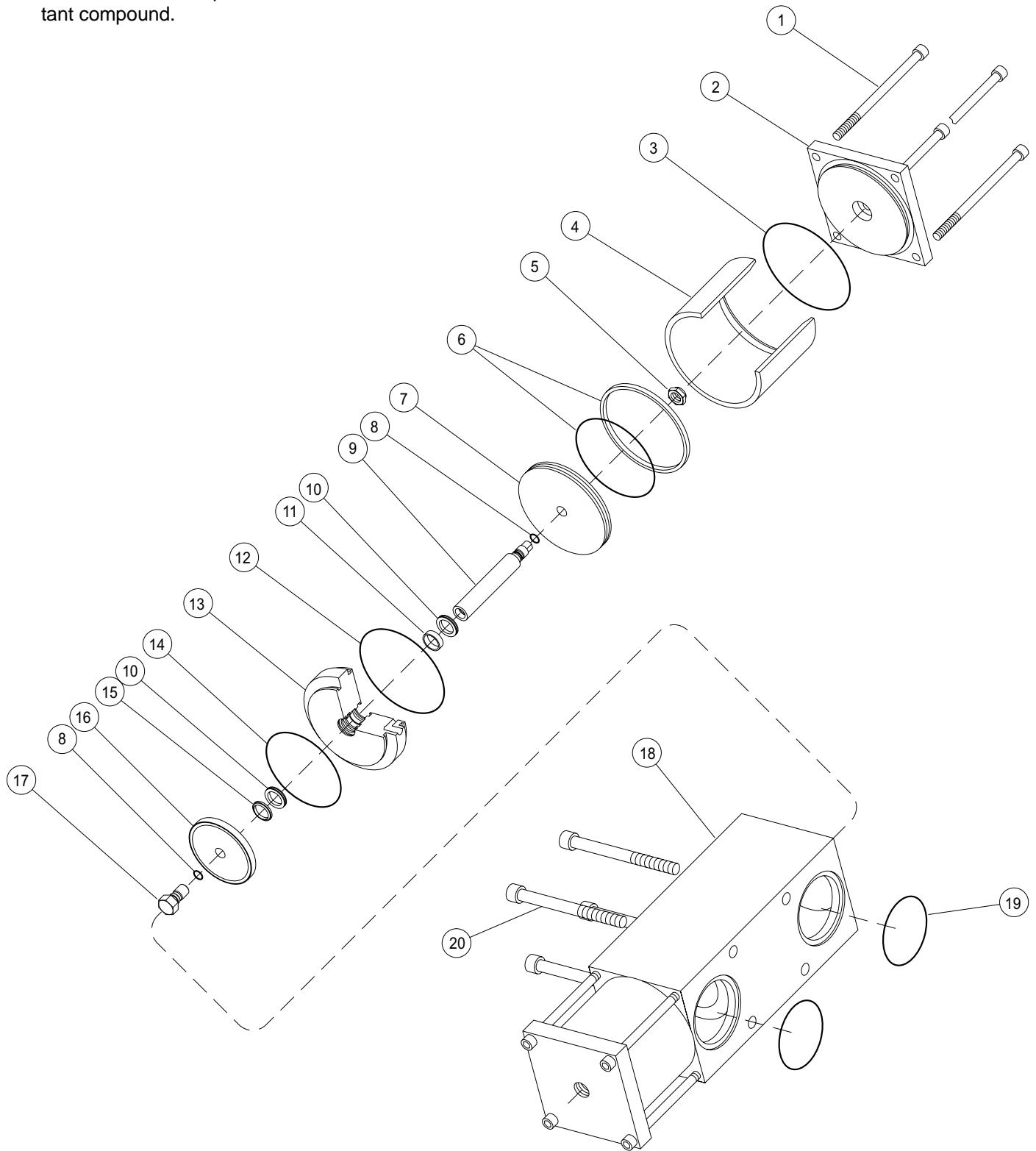

Figure 4.9
3" PURGE EXHAUST SWITCHING VALVE
(LS1500)

4.12 Purge and Outlet Check Valve Maintenance

(Models LS60 through LS760)

WARNING!

Ensure that the dryer is de-energized, valve isolated, and fully depressurized before attempting to remove or disassemble any dryer component or subassembly. Failure to do so may result in serious personal injury and/or equipment damage.

Note: The purge orifice [15] is specifically sized and drilled for your dryer. If the purge orifice [5] is lost or damaged, contact your local Deltech Sales Representative for the correct replacement.

Note: Do Not remove shoulder bolts [1] from the valve body [13] unless wear or damage necessitates replacement. If replacement is required, apply Loctite™ RC-680 to threads upon reassembly.

1. Clean and inspect all valve hardware upon disassembly. Replace all software and any hardware which appears damaged or abnormally worn. Closely inspect valve poppets [12], check balls [11], purge adjusting valve [7] and associated mating-sealing surfaces for any faults which could prevent positive sealing.
2. Apply an ultra-thin film of O-ring lubricant to items [3], [5], [9], and [10]. **Do not apply lubricant to check balls [11] or valve poppets [12].**

Purge and Outlet Check Valve		
Item	Description	Total
1	Shoulder Bolt	2
2	Sockethead Cap Screw	4
3	O-Ring	1
4	Roll Pin	2
5	O-Ring	2
6	Pipe Plug	2
7	Purge Adjusting Valve	1
8	Valve Guide	1
9	Tetraseal	1
10	O-Ring	1
11	Check Ball	2
12	Valve Poppet	2
13	Valve Body	1
14	Pipe Plug	2
15	Purge Orifice	2

IMPORTANT NOTICE

Due to potential damage of screwed fasteners from over torquing, fatigue, and corrosion, maintain the following procedure.

Inspect internal threads for conformity to ensure no damage was caused during previous assembly and/or disassembly, and remove all foreign debris.

Apply a light coat of Never Seize lubricant to the new sockethead cap screws provided in the repair kit. Hand tighten screws until snug. Torque as outlined in the schedule below.

TORQUE TABLE

SIZE	TORQUE
1/4 - 20	30 - 40 inch lbs. (3.4 - 4.5 Nm)
5/16 - 18	130 - 135 inch lbs. (14.7 - 15.3 Nm)
3/8 - 16	240 - 245 inch lbs. (27.1 - 27.7 Nm)
1/2 - 13	525 - 550 inch lbs. (59.3 - 62.2 Nm)

Nm = Newton-meters

NOTE:

1. When the unit is located in a corrosive environment, coat items (2) and (3) with a corrosion resistant compound.
2. Torque 1/4 - 20 screws to 40 in-lbs.
Torque 5/16 - 18 screws to 135 in-lbs.

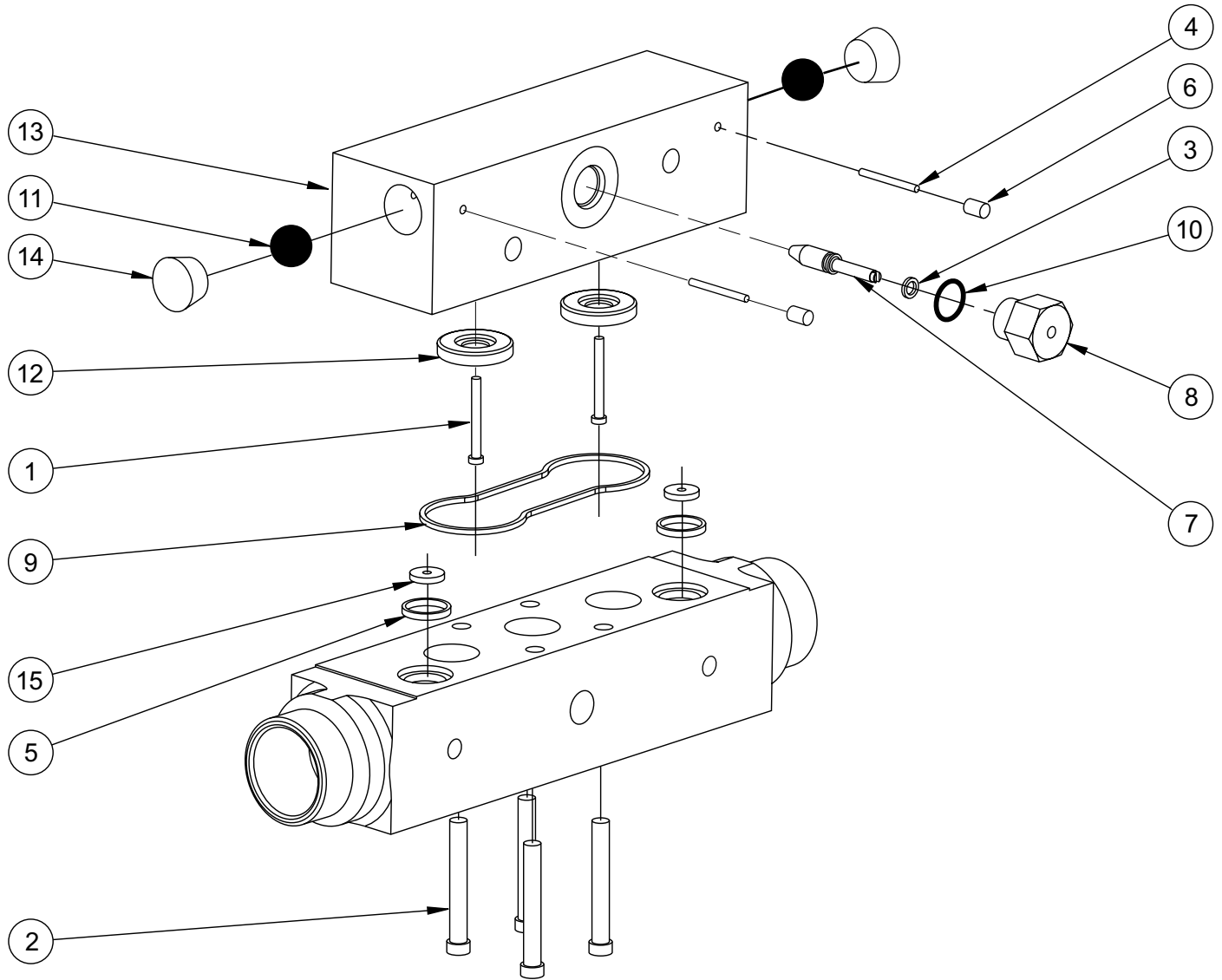

Figure 4.10
PURGE AND OUTLET CHECK VALVE ASSEMBLIES
(LS60, LS110, LS130, LS185, LS240, LS270, LS360, LS505, LS630, LS760)

4.13 3" Purge and Outlet Check Valve Maintenance

(Models LS1000 through LS1500)

WARNING!

Ensure that the Dryer is de-energized, valve isolated, and fully depressurized before attempting to remove or disassemble any Dryer component or subassembly. Failure to do so may result in serious personal injury and/or equipment damage.

Note: The purge orifice [4] is specifically sized and drilled for your dryer. If the purge orifice [4] is lost or damaged, contact your local Deltech Sales Representative for the correct replacement.

Note: Do not remove poppet guides [8] from the outlet check valve cover [2] unless wear or damage necessitates replacement.

1. Clean and inspect all valve hardware upon disassembly. Replace all software and any hardware which appears damaged or abnormally worn. Closely inspect valve poppets [7], check balls [15], purge adjusting valve [6] and associated mating-sealing surfaces for any faults which could prevent positive sealing.
2. Apply an ultra-thin film of O-ring lubricant to items [10], [11], [12], [17], and [18]. **Do not apply lubricant to check balls [15] or valve poppets [7].**

3" Purge and Outlet Check Valves		
Item	Description	Total
1	Flow Block	1
2	Check Valve Cover	1
3	Valve Housing	1
4	Purge Orifice	2
5	Hex Plug	2
6	Purge Adjusting Valve	1
7	Valve Poppet	2
8	Poppet Guide	2
9	Valve Spring	2
10	Square O-Ring	2
11	O-Ring	1
12	O-Ring	3
13	Sockethead Cap Screw	4
14	Sockethead Cap Screw	4
15	Check Ball	2
16	Valve Guide	1
17	O-Ring	1
18	Gauge Snubber	1
19	Square O-Ring	2

NOTE:

1. When the unit is located in a corrosive environment, coat items (13) and (14) with a corrosion resistant compound.
2. Torque 5/16 - 18 screws to 135 in-lbs.
Torque 3/8 - 16 screws to 245 in-lbs.

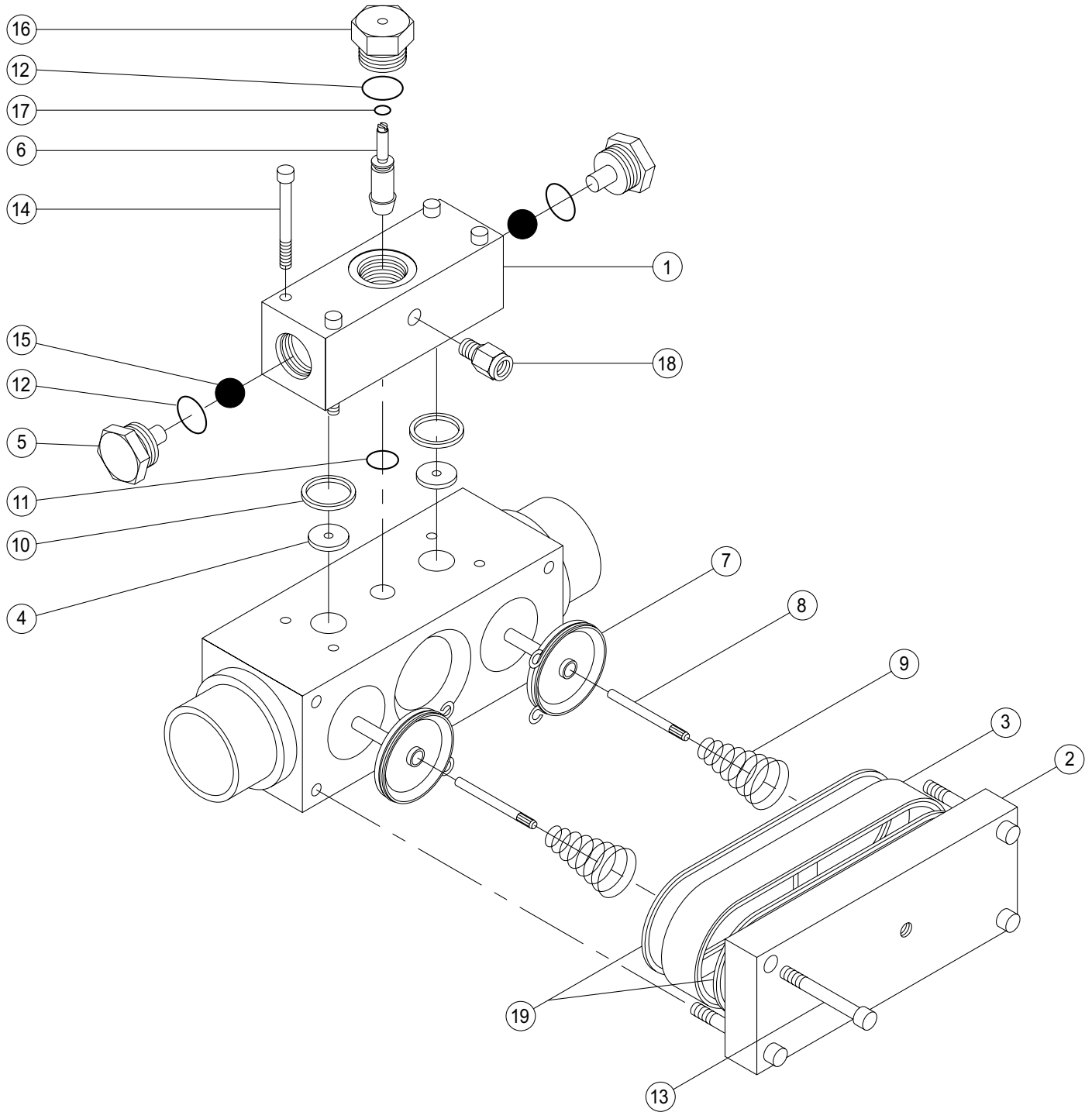

Figure 4.11
3" PURGE AND OUTLET CHECK VALVE ASSEMBLIES
(LS1000, LS1250, LS1500)

4.14 Remote Flow Restrictor Maintenance

(Model LS1250 only)

WARNING!

Ensure that the dryer is de-energized, valve isolated, and fully depressurized before attempting to remove or disassemble any dryer component or subassembly. Failure to do so may result in serious personal injury and/or equipment damage.

1. Remove muffler as follows:
 - a) **Provide adequate support for muffler and flow restrictor assembly.** Remove flow restrictor assembly from lower flange by equally loosening flange bolts. **Ensure that the method of support is prepared to accept the muffler and flow restrictor's full weight when the last bolt is removed (see following CAUTION).**

CAUTION: Exercise caution when lowering muffler and flow restrictor to prevent damaging control tubing and the Purge Pressure Indicator.

2. Remove, clean and inspect the "spring and orifice-type" flow restrictor. Install a new flow restrictor if damage is noted.

IMPORTANT: When installing Flow Restrictor, its springs **must be fully seated** in the spring receptacle. This **must** be accomplished for proper operation.

3. Reinstall muffler and flow restrictor assembly in the reverse order of removal.

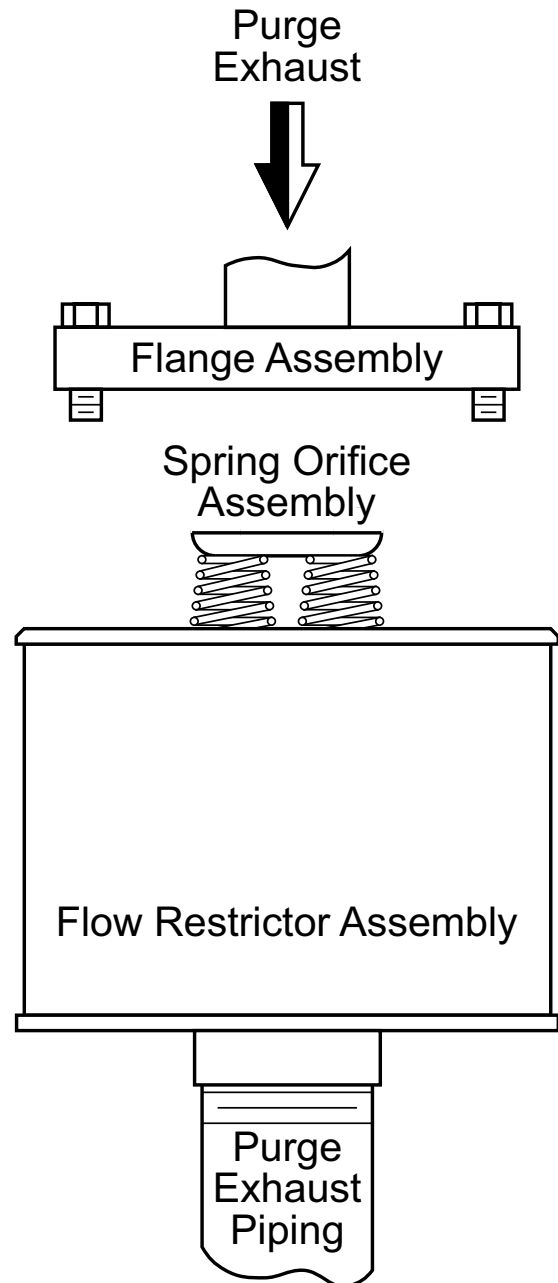

Figure 4.12

4.15 Flow Restrictor Maintenance (Models LS1500 through LS2580)

WARNING!

Ensure that the dryer and any associated prefilters and afterfilters are valve isolated and fully depressurized before attempting to remove or disassemble any components or subassemblies. Failure to do so may result in serious personal injury and/or equipment damage.

1. Clean and inspect the assembly. Check operation of the assembly. If a tendency to bind, erratic operation, damage and/or excessive wear is noted, disassemble and repair the assembly.

DISASSEMBLY/ASSEMBLY INSTRUCTIONS

1. Disassemble/Build the flow restrictor assembly in the order shown by the Flow Restrictor Assembly Diagram (Figure 4.14).
 - A) Hand tighten studs in sequence shown in Detail A.
 - B) Tighten studs in sequence shown to 30 ft-lbs. torque.
 - C) Leak check valve.

FLOW RESTRICTOR ASSEMBLY		
Item	Description	Total
1	Valve Body	1
2	Actuator Subassembly	1
3	Valve Flange	1
4	O-Ring	2
5	Hex Nut	8
6	Threaded Stud	4

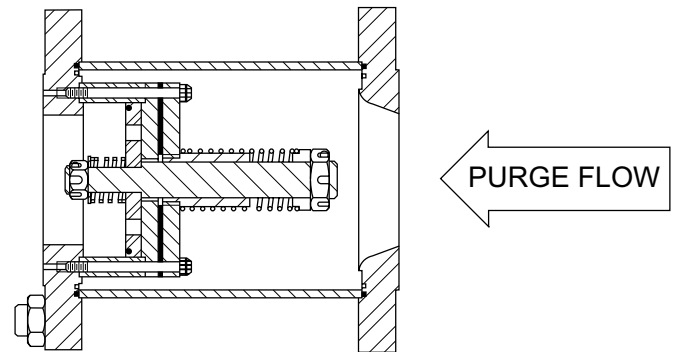

Figure 4.13

FLOW RESTRICTOR ASSEMBLY

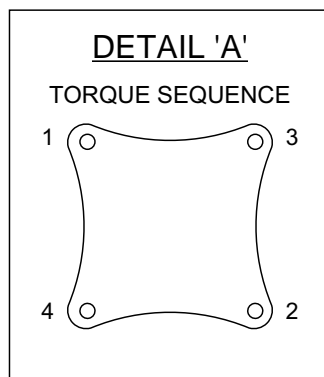
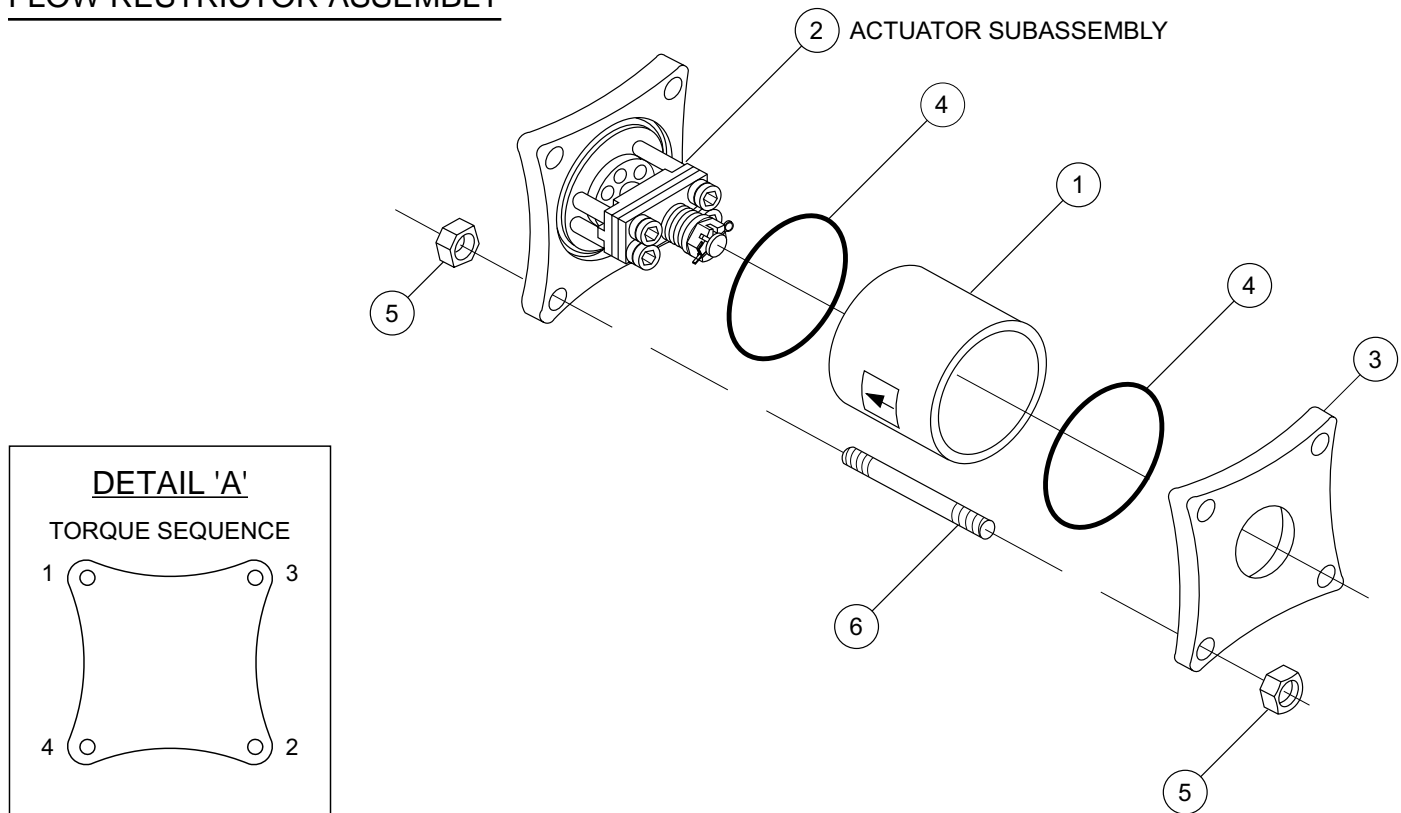

Figure 4.14

ACTUATOR SUBASSEMBLY		
Item	Description	Total
2A	Valve Flange	1
2B	Shaft Subassembly	1
2C	Spacer	4
2D	Mounting Plate	1
2E	Vibration Pad	1
2F	Retaining Plate	1
2G	Sockethead Cap Screw	4
2H	Lockwire	1
2J	Shaft Guide	1
2K	Compression Spring	1
2L	Spring Retainer	1
2M	Slotted Nut	1
2N	Cotter Pin	1

DISASSEMBLY/ASSEMBLY INSTRUCTIONS

ACTUATOR SUBASSEMBLY

1. Disassemble/Build the actuator subassembly in the order shown by the Actuator Subassembly Diagram (Figure 4.15).

- A) Secure the retaining plate in the jaws of a vise.
- B) Apply Loctite™ RC-620 to the threads of the shaft guide and thread it into the retaining plate. Using a 1" combination wrench tighten with approximately 80-100 lbs. force.

Note: Loctite™ RC-620 must be applied to the shaft guide to prevent loosening during operation.

- C) Tighten cap screws to 4-5 lbs. torque.
- D) Lockwire cap screws as shown in Detail B.

Note: Correctly applied lockwire will tend to tighten both cap screws.

ACTUATOR SUBASSEMBLY

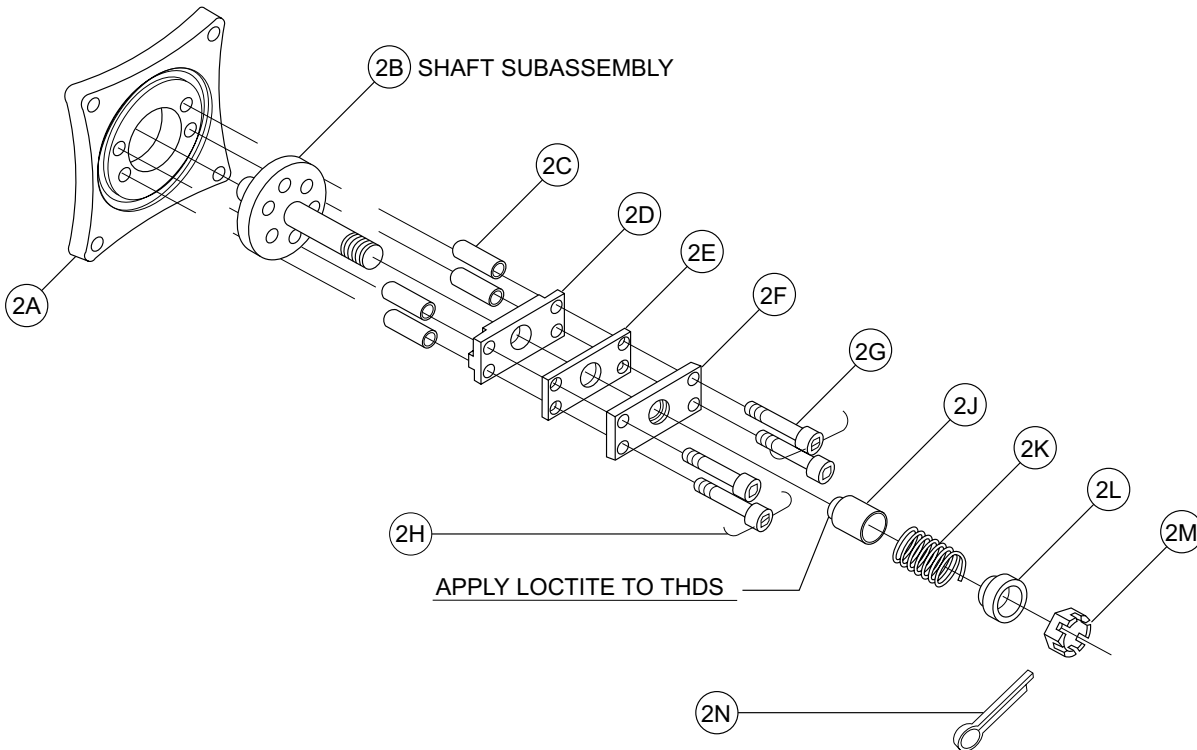

Figure 4.15

DETAIL 'B'	STEP '1'	STEP '2'	STEP '3'
<p>NOTE:</p> <p>1. WIRE SHOULD BE TWISTED TIGHTLY AND WITHOUT SLACK. USE WIRE TWISTER PLIERS.</p>	<p>1. INSERT WIRE THROUGH CONNECTOR '2'</p>	<p>1. TWIST 'A' & 'B'</p> <p>2. INSERT 'B' THROUGH CONNECTOR '1'</p>	<p>1. TWIST 'A' & 'B'</p>

2. Adjust orifice stroke.
 - A) Invert the actuator subassembly and place in a vice as shown in Detail C.
 - B) Gently press the flange to the orifice.
 - C) Tighten the nut until the spring retainer slightly contacts the shaft guide.
 - D) Continue tightening nut for an additional 1/2 turn.
 - E) Remove subassembly from the vice. Install the cotter pin.

Note: Orifice stroke adjustment is critical to the operation of the flow restrictor.

DISASSEMBLY/ASSEMBLY INSTRUCTIONS

SHAFT SUBASSEMBLY

1. Disassemble/Build the shaft subassembly in the order shown by the Shaft Subassembly Diagram (Figure 4.16).
2. Preload the orifice spring.
 - A) Tighten nut until slight contact is made with washer and orifice spring.
 - B) Continue tightening nut an additional 3 turns.
 - C) Install cotter pin.

Note: Preloading of the orifice spring is critical to the operation of the flow restrictor.

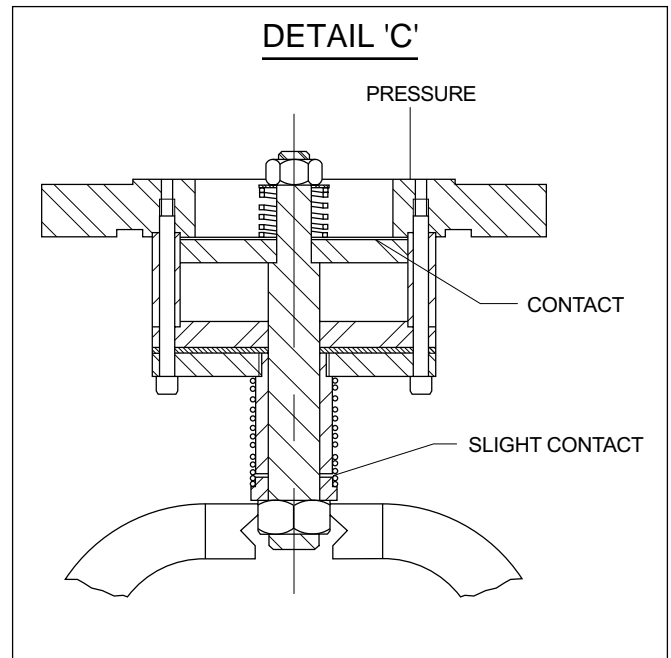

SHAFT SUBASSEMBLY		
Item	Description	Total
2B1	Poppet Shaft	1
2B2	Orifice Plate	1
2B3	Orifice Spring	1
2B4	Washer	1
2B5	Slotted Nut	1
2B6	Cotter Pin	1

SHAFT SUBASSEMBLY

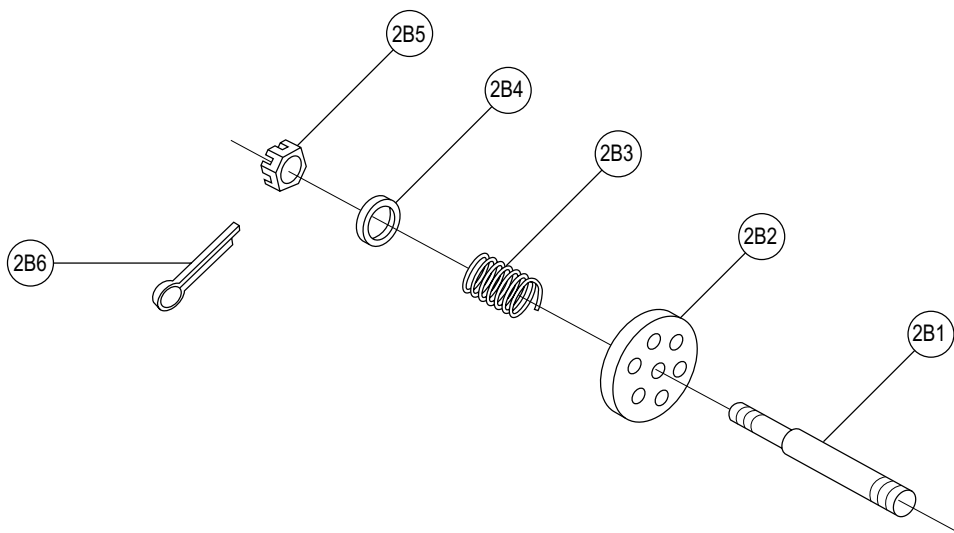

Figure 4.16

4.16 Purge Adjusting Valve

(Models LS2070 and LS2580)

WARNING!

Ensure that the dryer is de-energized, valve isolated and fully depressurized before attempting to remove or disassemble any dryer component or subassembly. Failure to do so may result in serious personal injury and/or equipment damage.

Note: Removal of valve body [4] is not required unless replacement of valve body is necessary.

1. Clean and inspect all valve hardware upon disassembly. Replace all software and any hardware which appears damaged or abnormally worn.
2. Apply an ultra-thin film of O-ring lubricant to item [2] before reassembly.

Item	Description	Total
1	Retaining Ring	1
2	O-ring	2
3	Valve Stem	1
4	Valve Body	1

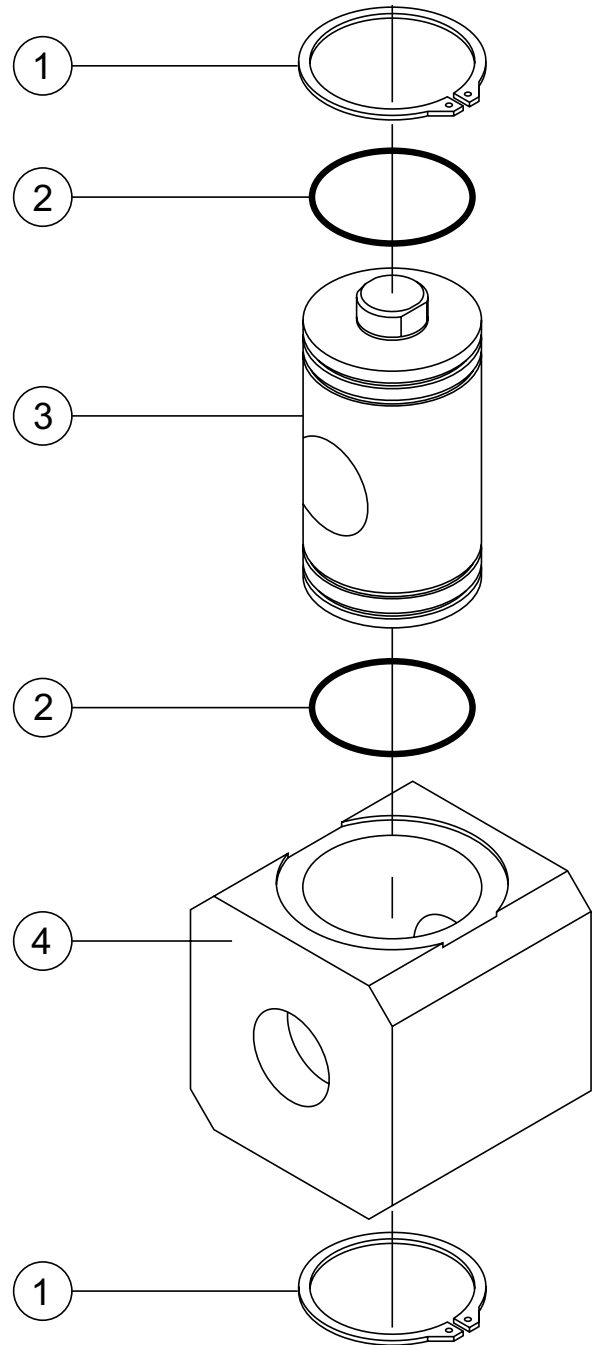

Figure 4.17

4.17 Pilot Gas Filter Maintenance

(Models LS2070 and LS2580)

WARNING!

Ensure that the dryer is de-energized, valve isolated, and fully depressurized before attempting to remove or disassemble any dryer component or subassembly. Failure to do so may result in serious personal injury and/or equipment damage.

Note: Flow through filter assembly is from outside of filter cartridge to the inside (center).

1. Clean and inspect all hardware upon disassembly. Replace filter cartridge, software, and any hardware which appears damaged or abnormally worn.
2. Apply an ultra-thin film of O-ring lubricant to filter cartridge's O-ring and O-ring [2].
3. Close filter bleed valve [6] following reassembly.

Item	Description	Total
1	Head Assembly	1
2	O-Ring	1
3	Filter Cartridge (non-cleanable)	1
4	Filter Bowl	1
5	Band Clamp	1
6	Filter Bleed Valve	1

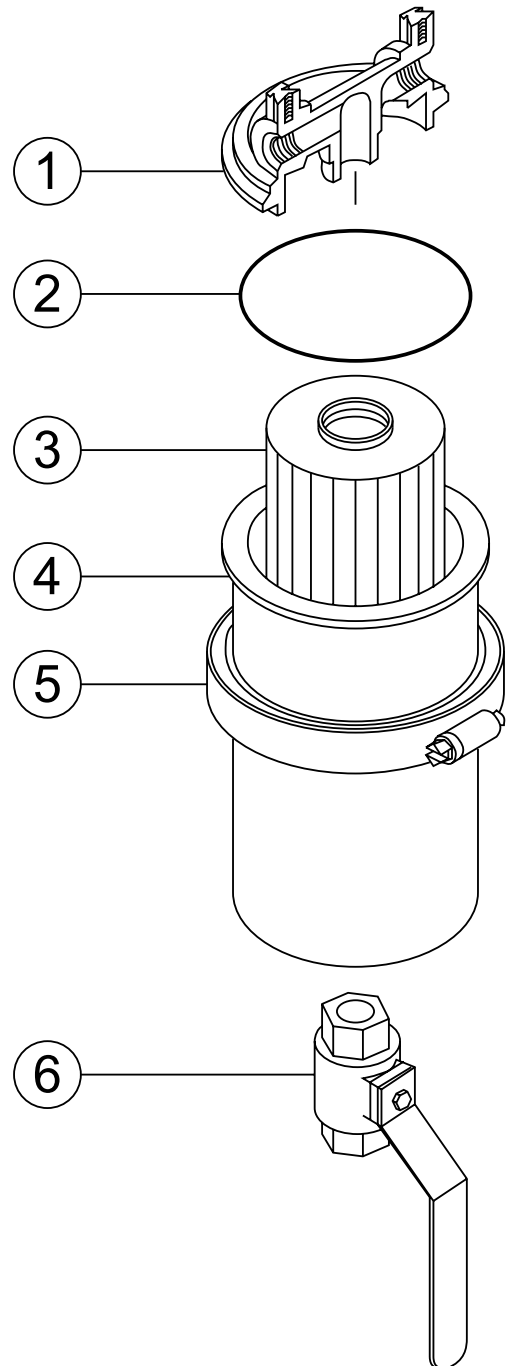

Figure 4.18

5 Troubleshooting Guide

WARNING!

Ensure that the Dryer and any associated Prefilters and Afterfilters are valve isolated and fully depressurized before attempting to remove or disassemble any subassemblies or components. Failure to do so may result in serious personal injury and/or equipment damage.

WARNING!

Some of the following troubleshooting checks require entering the Dryer Control System enclosure while the Dryer's Electrical Power Supply is energized. **THEREFORE, A POTENTIAL ELECTRICAL SHOCK HAZARD EXISTS.** These checks should be conducted by a qualified electrical technician or a Deltech authorized field service engineer **ONLY**. The Dryer's Electrical Power Supply must be de-energized before any electrical maintenance or repair work is conducted.

CAUTION: Do not open or enter the Dryer Control System without exercising proper precautions for **Static Sensitive Devices**. **Do not** remove the factory programmed microcomputer chip or any I.C. chip from the Logic Control Circuit Board. Improper removal or handling will cause irreparable damage to these highly Static Sensitive components. Damage to these components will render the Dryer Control System inoperative until replacement is accomplished by a Deltech authorized field service engineer. **Do not** remove the program identification sticker from the microcomputer chip.

Important: Water molecules can diffuse through a pinhole size leak even though pressure inside the piping is several hundred PSIG. It is not at all uncommon to have a minute pinhole leak in a gas line cause an increase in dew point from -40°F to -10°F at a distance of forty or more feet downstream of the leak.

PROBLEM/POSSIBLE CAUSE	CHECKS AND REMEDY
<p>Dew point degradation</p> <ol style="list-style-type: none"> 1. Insufficient or excessive purge gas flow during regeneration. 2. Inlet gas pressure is below the design pressure specified on the Dryer Specification Label located on the inside cover of the dryer control system enclosure. 3. Inlet gas flow (SCFM) is above the dryer's design flow rate. 	<ol style="list-style-type: none"> 1. Refer to the Calculation of Purge Pressure Setting instructions in Appendix A (refer to Appendix C for -100°F pdp). Ensure that the dryers purge flow has been properly calculated and adjusted. 2. Check the dryer's inlet pressure and correct if necessary. The efficiency of the dryer decreases as the inlet pressure decreases. 3. Verify the actual flow rate through dryer. Reduce flow rate if operating above the inlet flow rate specified on the Dryer Specification Label located on the inside cover of the dryer control system enclosure.

PROBLEM/POSSIBLE CAUSE

CHECKS AND REMEDY

<ol style="list-style-type: none">4. Inlet gas temperature is above the dryer's design inlet temperature specified on the Dryer Specification Label located on the inside cover of the dryer system control enclosure.5. Liquids entering the dryer inlet. 6. Desiccant is badly broken or coated with oil. The "normally white" desiccant will appear tan or brown if oil contamination has occurred.7. Union or other piping/component leaks at dryer outlet manifold or downstream of dryer outlet.	<ol style="list-style-type: none">4. Check the compressor aftercooler and cooling system. Adjust as necessary to bring the dryer inlet temperature to design specification.5. Isolate and depressurize Prefilter Assembly. Inspect prefilter cartridges and end seals for loosening and/or damage. Tighten or replace as necessary. CAUTION: Each component of an Deltech Air Purification System has been selected to compliment the performance of the other components of the system. Therefore, use of unauthorized parts or supplies or improper operation will degrade system performance.5a. Check the compressor aftercooler for tube leakage if the aftercooler uses water as the cooling medium.5b. Inspect the prefilter automatic drain valve or drain trap. Ensure that it is not clogged, and is draining properly. Repair or replace as necessary, if a problem is noted.6. Shutdown and Depressurize Dryer. Inspect desiccant through fill ports and replace if badly broken, coated with oil or otherwise fouled. Inspect prefilter if fouling is noted.7. Soap test the dryer outlet manifold and piping downstream of dryer. Repair ALL leaks noted.
<p>Moisture Indicator has changed color from BLUE (dry) to a PINK (wet) indication.</p> <ol style="list-style-type: none">1. Moisture indicator's bleed valve is closed.2. Moisture indicator supply valve is closed.3. Moisture indicator is internally clogged, preventing gas from exiting through indicator's bleed valve.4. Sample tubing to Moisture Indicator is leaking permitting "wet" atmospheric air to enter tubing and contaminate dry gas sample.5. If the previous items 1 through 4 have been checked, and the Moisture Indicator fails to return to blue within 3 to 5 hours, an actual dew point problem may exist.	<ol style="list-style-type: none">1. Open bleed valve installed in moisture indicator body until a slight continuous gas bleed is felt exhausting from bleed valve's drilled exhaust port. Granular indicating desiccant MUST remain motionless after final adjustment.2. Fully open the moisture indicator supply valve. Adjust indicator's bleed valve as instructed in previous step 1.3. Refer to Moisture Indicator Recharging Procedure section of this manual for disassembly instructions. Clean or replace components as necessary.4. Perform a soap bubble leak test on indicator's tubing and fittings. Tighten or repair all noted points-of-leakage.5. Refer to "dew point degradation" section of this Troubleshooting Guide. Determine and eliminate fault. Important: If granular indicating desiccant is discolored (any color other than Light Pink to Dark Blue, replace the granular indicator.

PROBLEM/POSSIBLE CAUSE

CHECKS AND REMEDY

Back pressure on a desiccant chamber during the regeneration cycle. (Chamber's pressure gauge indicates above zero (0) PSIG.)

Note: The presence of back pressure will result in insufficient regeneration followed by dew point degradation. An off-stream chamber's pressure gauge MUST indicate zero (0) PSIG throughout all regeneration cycles.

1. Purge Adjusting Valve is supplying excessive purge gas to regenerating chamber as indicated by the Purge Pressure Indicator (gauge).

Note: If correct setting is unknown, refer to the Calculation of Purge Pressure Setting instructions in Appendix A.

2. Purge or Outlet Check Valve seat is worn, damaged, or fouled (allowing slight pressure leakage to enter regenerating chamber).
3. Off-stream chamber's Inlet Switching Valve **or** on-stream chamber's Purge Exhaust Switching Valve seat is worn, damaged or fouled (allowing slight pressure leakage to enter regenerating chamber).

1. SLOWLY rotate Purge Adjusting Valve until correct purge pressure setting is noted on the Purge Pressure Indicator.

Note: The purge pressure setting can only be read and adjusted when the off-stream chamber has **depressurized** for regeneration. When the off-stream chamber is pressurized the Purge Pressure Indicator will read **system pressure**.

2. **Shutdown and Depressurize Dryer.** Refer to the Purge and Outlet Check Valve Maintenance procedure which is applicable to your specific dryer model. Disassemble, clean and inspect the Purge and Outlet Check Valves. Replace all worn or damaged components as noted.
3. **Shutdown and Depressurize Dryer.** Refer to the Inlet Switching Valve and Purge Exhaust Switching Valve Maintenance procedures which are applicable to your specific dryer model. Disassemble, clean and inspect the Inlet Switching Valves and Purge Exhaust Switching Valves. Replace all worn or damaged components as noted.

Loss of power to Operating Status and Alarm Indicators (no illumination). (Both chambers are at line pressure, as indicated by the left and right chamber pressure gauges.)

1. Loss of power supply to (or at) dryer's electrical disconnect switch, or breaker (customer supplied).
2. Loose connections at customer power connections (H, N, GND).
3. Control system's power fuse (F1) is blown.
4. Damaged components.

1. Check power disconnect switch (or breaker) CLOSED. If tripped breaker or blown fuse is noted, investigate and remedy cause.
2. **De-energize Dryer Power Supply.** Check power supply input wiring connections (H, N, GND).
3. **De-energize Dryer Power Supply.** Replace fuse if blown, investigate and remedy cause.
4. For damaged solid state components and/or circuit boards of microprocessor units, contact your local Deltech Sales Representative for assistance.

PROBLEM/POSSIBLE CAUSE

CHECKS AND REMEDY

<p>Excessive pressure drop across dryer.</p> <ol style="list-style-type: none">1. Badly broken, dusted or fouled desiccant.2. Inlet flow rate (SCFM) is exceeding the dryer's design flow rate as specified on the Dryer Specification Label located on the inside cover of the dryer system control enclosure.3. Desiccant retaining screens are clogged or fouled.4. Inlet and/or outlet pressure gauges are out of calibration, or damaged.	<ol style="list-style-type: none">1. Shutdown and Depressurize Dryer. Inspect desiccant through fill ports and replace if badly broken, dusted or fouled. Note: If the "normally white" desiccant is fouled or discolored, inspect prefilter cartridges and drain valve or trap.2. Reduce the inlet flow rate as necessary to meet the dryer's design flow rate.3. Shutdown and Depressurize Dryer. Drain desiccant from chamber. Inspect retaining screens through fill and drain ports and clean if fouling is noted. Investigate and remedy source of fouling. CAUTION: Desiccant may be reinstalled if it is not fouled or badly broken.4. Shutdown and Depressurize Dryer. Replace damaged, faulty or out-of-calibration gauges.
<p>Chamber depressurization (prior to each regeneration cycle) is excessively loud.</p> <ol style="list-style-type: none">1. The purge exhaust flow restrictor is damaged, or not fully seated.	<ol style="list-style-type: none">1. Shutdown and Depressurize Dryer. Proceed as follows:<ol style="list-style-type: none">a) For Model LS1250 only.<ol style="list-style-type: none">1. Provide adequate support for muffler and flow restrictor assembly. Remove flow restrictor assembly from lower flange by equally loosening flange bolts. Ensure that the method of support is prepared to accept the Muffler's full weight when the last bolt is removed (see following CAUTION). CAUTION: Exercise caution when lowering flow restrictor and muffler to prevent damaging control tubing, and the Purge Pressure Indicator.2 Remove, clean and inspect the "spring and orifice-type" flow restrictor. Install a new flow restrictor if damage is noted. Important: When installing Flow Restrictor, its springs MUST be fully seated in the spring receptacle. This MUST be accomplished for proper operation.3 Reinstall muffler and flow restrictor in the reverse order of removal.

PROBLEM/POSSIBLE CAUSE

CHECKS AND REMEDY

	<p>b) For Models LS1500 through LS2580</p> <p>WARNING! Removal of the Flow restrictor should not be done unless the piping to the Purge Exhaust Muffler is adequately supported. Failure to do so may result in serious personal injury and/or equipment damage.</p> <ol style="list-style-type: none"> 1. Remove Flow Restrictor from the line and refer to the Flow Restrictor Maintenance Procedure. 2. Disassemble, clean, inspect and adjust as required. Replace all worn or damaged parts as noted.
<p>Valve Failure Alarm with excessive pressure exhausting through muffler. BOTH chamber pressure gauges read below normal system pressure.</p> <ol style="list-style-type: none"> 1. During Depressurization Cycle. Off-stream chamber's Inlet Switching Valve has failed to close due to fouled or worn valve internals. 2. During Depressurization Cycle. Dryer Models LS60 through LS1500 Chamber Inlet Switching Valve has failed to close due to the associated solenoid valve's (B or C) failure to energize. Dryer Models LS2070 and LS2580 Off-stream chamber's Inlet Switching Valve has failed to close due to the associated solenoid valve's (B or C) failure to energize. 3. During Depressurization Cycle. Purge or Outlet Check Valve internals are worn, damaged, or fouled, permitting "blowby" of on-stream chamber's pressure (through faulty check valve) to the off-stream chamber. 	<ol style="list-style-type: none"> 1. Check for pilot gas pressure at off-stream chamber inlet valve's pilot tubing connection or on-stream chamber exhaust valve's pilot tubing connection. If pilot pressure is present, Shutdown and Depressurize Dryer. Disassemble, clean and inspect the Switching Valve. Replace all worn or damaged parts as noted. 2. Check indicator lights at solenoid block to determine whether energized. Indicator light should be lit if the solenoid coil is energized. If not, open control enclosure and check MEC Board for output signal to solenoid valve. <ol style="list-style-type: none"> a) If voltage is present and the indicator at the solenoid block is not lit, De-energize Dryer Power Supply. Press the manual override on solenoid valve to determine if functioning. If functioning mechanically, the solenoid valve coil is defective. Replace solenoid valve coil. Note: The dryer MUST be depressurized to change coils on a solenoid. b) If voltage is present and the inlet valve doesn't open (models OP-M15 through OP-M300) or close (models OP-M400 and OP-M500) when overriding the solenoid valve, the solenoid valve is defective. Replace solenoid valve. c) If voltage is not present, replace MEC Board. 3. Shutdown and Depressurize Dryer. Disassemble, clean and inspect the Purge and Outlet Check Valves. Replace all worn or damaged components as noted.

PROBLEM/POSSIBLE CAUSE**CHECKS AND REMEDY**

<p>4. During Repressurization Cycle. Purge Exhaust Switching Valve has failed to close due to fouled or worn valve internals.</p>	<p>4. Check for pilot gas pressure at on-stream chamber exhaust valve's pilot tubing connection.</p> <p>If pilot pressure is present, Shutdown and Depressurize Dryer. Disassemble, clean and inspect the Switching Valve. Replace all worn or damaged parts as noted.</p>
<p>Valve Failure Alarm with excessive pressure exhausting through muffler. BOTH chamber pressure gauges read normal system pressure.</p> <p>1. During Depressurization Cycle. Off-stream chamber's Purge Exhaust Valve has failed to open due to the associated solenoid valve's (A or D) failure to energize.</p>	<p>1. Check indicator lights at solenoid block to determine whether energized. Indicator light should be lit if the solenoid coil is energized. If not, open control enclosure and check MEC Board for output signal to solenoid valve.</p> <p>a) If voltage is present and the indicator at the solenoid block is not lit, Shutdown and Depressurize Dryer. Provide a separate pilot gas source.</p> <p>With the dryer controls de-energized, press the manual override on solenoid valve to determine if functioning. If functioning mechanically (the purge exhaust valve should open), the solenoid valve coil is defective. Replace solenoid valve coil.</p> <p>Note: The dryer MUST be depressurized to change coils on a solenoid.</p> <p>b) If voltage is present and the purge exhaust valve doesn't open when manual overriding the solenoid valve, the solenoid valve is defective. Replace solenoid valve.</p> <p>c) If voltage is not present, replace MEC Board.</p>
<p>Valve Failure Alarm.</p> <p>1. Damaged or out of calibration pressure sensor.</p>	<p>1. Shutdown and Depressurize Dryer. Replace pressure sensor.</p>

PROBLEM/POSSIBLE CAUSE

CHECKS AND REMEDY

High Humidity Warning

Note: A High Humidity Warning will ALWAYS cause the control system to automatically shift to fixed cycle operation.

1. Compu-Save Sensor has sensed a moisture overload condition within a desiccant bed due to the presence of one (or both) of the following conditions:

1a. Inlet flow rate (SCFM) is above dryer's design inlet flow rate, as specified on the Dryer Specification Label located on the inside cover of the dryer system control enclosure. Excessive flow rates will result in excessive moisture loading of the desiccant beds. This overload condition would raise the Compu-Save Sensor's moisture related frequency signal above the microcomputer's comparator set point range, and therefore, would be interpreted as a High Humidity Warning.

1b. Gas has been allowed to flow through dryer for an extended period of time with the dryer control system de-energized. When the control system is de-energized, one chamber is automatically placed on-stream and regeneration is not conducted.

Without regeneration, the desiccant beds will eventually be overloaded with moisture. When the power supply was re-energized, the moisture-overload condition raised the Compu-Save Sensor's moisture related frequency signal above the microcomputer's comparator set point range, and therefore, would be interpreted as a High Humidity Warning.

2. Purge Adjusting Valve is supplying excessive purge gas to regenerating chamber as indicated by the Purge Pressure Indicator (gauge).

Note: If correct setting is unknown, refer to the Calculation of Purge Pressure Setting instructions in Appendix A.

3. Purge or Outlet Check Valve seat is worn, damaged, or fouled (allowing slight pressure leakage to enter regenerating chamber).

1a. Verify the actual inlet flow rate. Reduce flow rate if operating above the inlet flow rate specified on the Dryer Specification Label.

If the verified inlet flow rate is not exceeding the specified design flow rate, proceed to POSSIBLE CAUSE #1b.

1b. Allow the dryer to remain energized and operating in a fixed cycle.

The High Humidity Alarm will de-energize (followed by the control system's return to Energy Management System (EMS) Active) AFTER the excessive moisture-load has been purged from the desiccant beds.

2. 1. SLOWLY rotate Purge Adjusting Valve until correct purge pressure setting is noted on the Purge Pressure Indicator.

Note: The purge pressure setting can only be read and adjusted when the off-stream chamber has **depressurized** for regeneration. When the off-stream chamber is pressurized the Purge Pressure Indicator will read **system pressure**.

3. **Shutdown and Depressurize Dryer.** Refer to the Purge and Outlet Check Valve Maintenance procedure which is applicable to your specific dryer model. Disassemble, clean and inspect the Purge and Outlet Check Valves. Replace all worn or damaged components as noted.

PROBLEM/POSSIBLE CAUSE**CHECKS AND REMEDY**

<p>4. Off-stream chamber's Inlet Switching Valve or on-stream chamber's Purge Exhaust Switching Valve seat is worn, damaged or fouled (allowing slight pressure leakage to enter regenerating chamber).</p>	<p>4. Shutdown and Depressurize Dryer. Refer to the Inlet Switching Valve and Purge Exhaust Switching Valve Maintenance procedures which are applicable to your specific dryer model. Disassemble, clean and inspect the Inlet Switching Valves and Purge Exhaust Switching Valves. Replace all worn or damaged components as noted.</p>
<p>Fixed Cycle Electronic Timer Control (Models LS60 through LS1000 ONLY)</p> <p>Dryer chambers fail to switch.</p> <p>1. Timer failure.</p> <p>2. Off-stream chamber's Inlet Switching Valve has failed to close due to fouled or worn valve internals.</p> <p>3. Off-stream chamber Inlet Switching Valve has failed to close due to the associated solenoid valve's (A or B) failure to energize. Both chambers are at line pressure.</p> <p>4. Purge Exhaust Switching Valve has failed to close due to fouled or worn valve internals.</p> <p>5. Purge or Outlet Check Valve internals are worn, damaged, or fouled, permitting "blowby" of on-stream chamber's pressure (through faulty check valve) to the off-stream chamber.</p>	<p>1a. Verify power is being supplied to dryer.</p> <p>1b. Replace timer if necessary.</p> <p>2. Check for pilot gas pressure at inlet valve's pilot tubing connections.</p> <p>If there is pilot pressure at the off-stream chamber's pilot tubing connection and no pilot pressure at the on-stream chamber's pilot tubing connection, refer to the Inlet Switching Valve Maintenance procedure which is applicable to your specific dryer model.</p> <p>Shutdown and Depressurize Dryer. Disassemble, clean and inspect the Inlet Switching Valve. Replace all worn or damaged parts as noted.</p> <p>3. Repeat check #2.</p> <p>If there is no pilot gas pressure present at the off-stream chamber's pilot gas tubing connection, check voltage to solenoid valve.</p> <p>If voltage is present. De-energize Dryer Power Supply. Replace solenoid valve.</p> <p>If voltage is not present, replace timer.</p> <p>4. Check for pilot gas leak through the piston seal pilot gas exhaust hole located on the bottom of the valve block.</p> <p>If a pilot gas pressure leak is present, refer to the Purge Exhaust Switching Valve Maintenance procedure which is applicable to your specific dryer model.</p> <p>Shutdown and Depressurize Dryer. Disassemble, clean and inspect the Purge Exhaust Switching Valve. Replace all worn or damaged parts as noted.</p> <p>5. Shutdown and Depressurize Dryer. Refer to the Purge and Outlet Check Valve Maintenance Procedure which is applicable to your specific dryer model.</p> <p>Disassemble, clean and inspect the Purge and Outlet Check Valves. Replace all worn or damaged components as noted.</p>

PROBLEM/POSSIBLE CAUSE**CHECKS AND REMEDY**

<p>Automatic drain valve continually discharging or venting.</p> <ol style="list-style-type: none">1. Clogged diaphragm.2. Short in electrical component.	<ol style="list-style-type: none">1. Clean diaphragm.2. Check and replace connector or timer assembly.
<p>Automatic drain valve not discharging.</p> <ol style="list-style-type: none">1. No electrical power.2. Timer malfunction.3. Solenoid coil malfunction.4. Clogged ports.	<ol style="list-style-type: none">1. Check and correct power supply and connections.2. Replace timer assembly.3. Replace solenoid coil.4. Clean ports.
<p>No response when push-to-test button on automatic drain valve is pressed.</p> <ol style="list-style-type: none">1. No electrical power.2. Timer malfunction.	<ol style="list-style-type: none">1. Check and correct power supply and connections.2. Replace timer assembly.

Appendix A

Purge Curves

HYDROBLOC LS SERIES PURGE CURVES

Calculation of Purge Pressure Setting

1. Determine air pressure (psig) at the dryer inlet.
2. Refer to Table A-1. Determine the inlet airflow for your model and inlet air pressure.
3. To calculate purge flow consumption on the critical orifice curve:

$$\frac{\text{Inlet Flow (SCFM)} \times 14.7 \text{ PSIG}}{\text{Inlet Pressure (PSIG)} + 14.7 \text{ PSIG}} \times 1.15 = \text{Purge (SCFM)}$$
4. Locate the Critical Orifice Calibration Curve that has been sized for your specific dryer model.
5. Cross the Purge Flow requirement calculated above to the same number on the Critical Orifice Calibration Curve. Follow this line vertically and then horizontally once intersection is made with the curve line to find the actual purge pressure setting.
6. Locate the Purge Adjusting Valve. Slowly rotate dryer's Purge Adjusting Valve until the Purge Pressure Indicator indicates the calculated purge pressure setting. (See following Note).

Note: The purge pressure can only be read and adjusted when an off-line desiccant chamber has de-pressurized for regeneration. (When the off-line chamber is pressurized, the Purge Pressure Indicator will read "system pressure".)

Table A - 1 Inlet Airflow at Various Inlet Air Pressures¹

Model	Inlet Air Pressure (psig)									
	60	70	80	90	100	110	120	130	140	150
	Average Inlet Airflow (scfm) ²									
LS60	39	44	50	55	60	65	70	76	81	86
LS110	72	81	91	100	110	120	129	139	148	158
LS130	85	96	107	119	130	141	153	164	175	187
LS185	120	137	153	169	185	201	217	233	250	266
LS240	156	177	198	219	240	261	282	303	324	345
LS270	176	199	223	246	270	294	317	341	364	388
LS360	234	266	297	329	360	391	423	454	486	517
LS505	329	373	417	461	505	549	593	637	681	725
LS630	410	465	520	575	630	685	740	795	850	905
LS760	495	561	627	694	760	826	893	959	1025	1091
LS1000	651	738	826	913	1000	1087	1174	1262	1349	1436
LS1250	814	923	1032	1141	1250	1359	1468	1577	1686	1795
LS1500	977	1108	1238	1369	1500	1631	1762	1892	2023	2154
LS2070	1348	1529	1709	1890	2070	2250	2431	2611	2792	2972
LS2580	1680	1905	2130	2355	2580	2805	3030	3255	3480	3705

¹ Maximum inlet air pressure, 150 psig.

² Based on 100°F inlet air temperature and -40°F pressure dew point. Maximum recommended inlet temperature, 120°F. For capacity at inlet temperature higher than 100°F, consult your local distributor.

HYDROBLOC LS SERIES PURGE CURVES

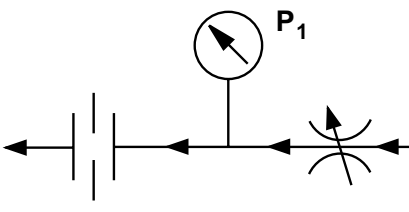
Orifice Dia. .129 Gas: Air Temp: 100°F C _D : .65	
--	--

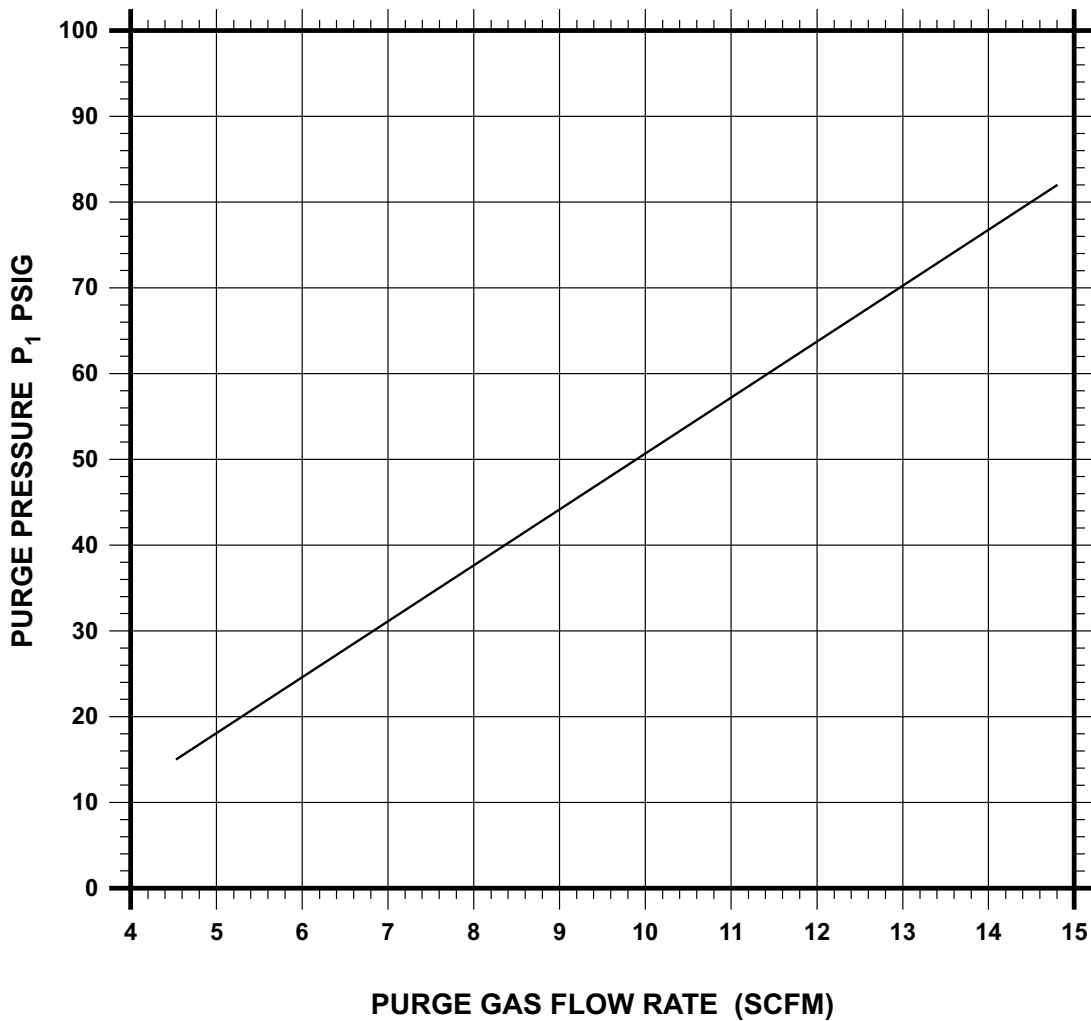
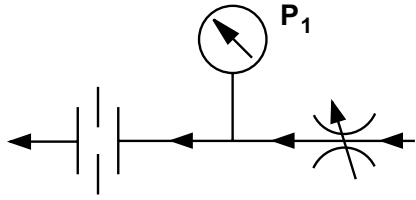

Figure A.1 — Critical Orifice Calibration Curve
(LS60)

HYDROBLOC LS SERIES PURGE CURVES

<p>Orifice Dia. .156 Gas: Air Temp: 100°F C_D: .65</p>	
---	--

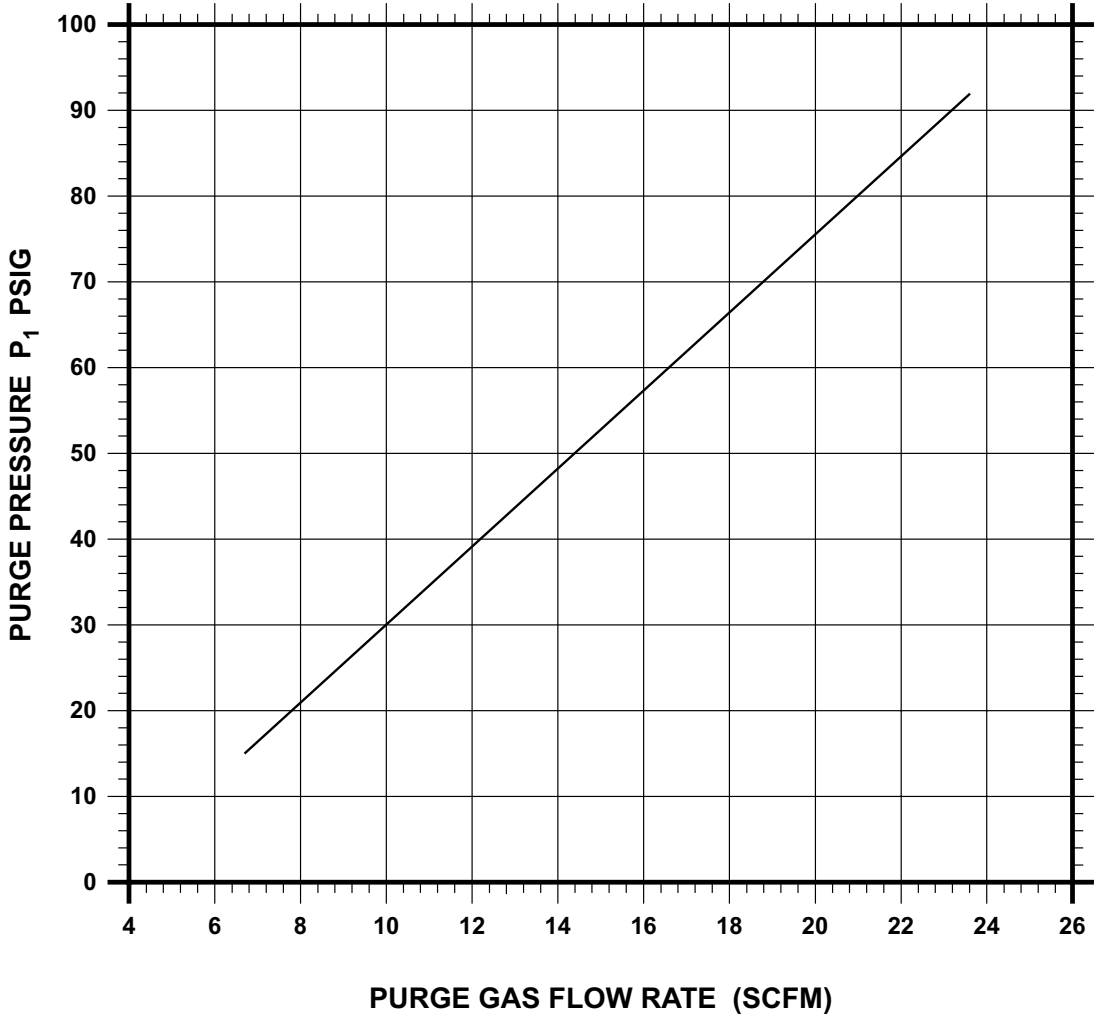

Figure A.2 — Critical Orifice Calibration Curve
(LS110)

HYDROBLOC LS SERIES PURGE CURVES

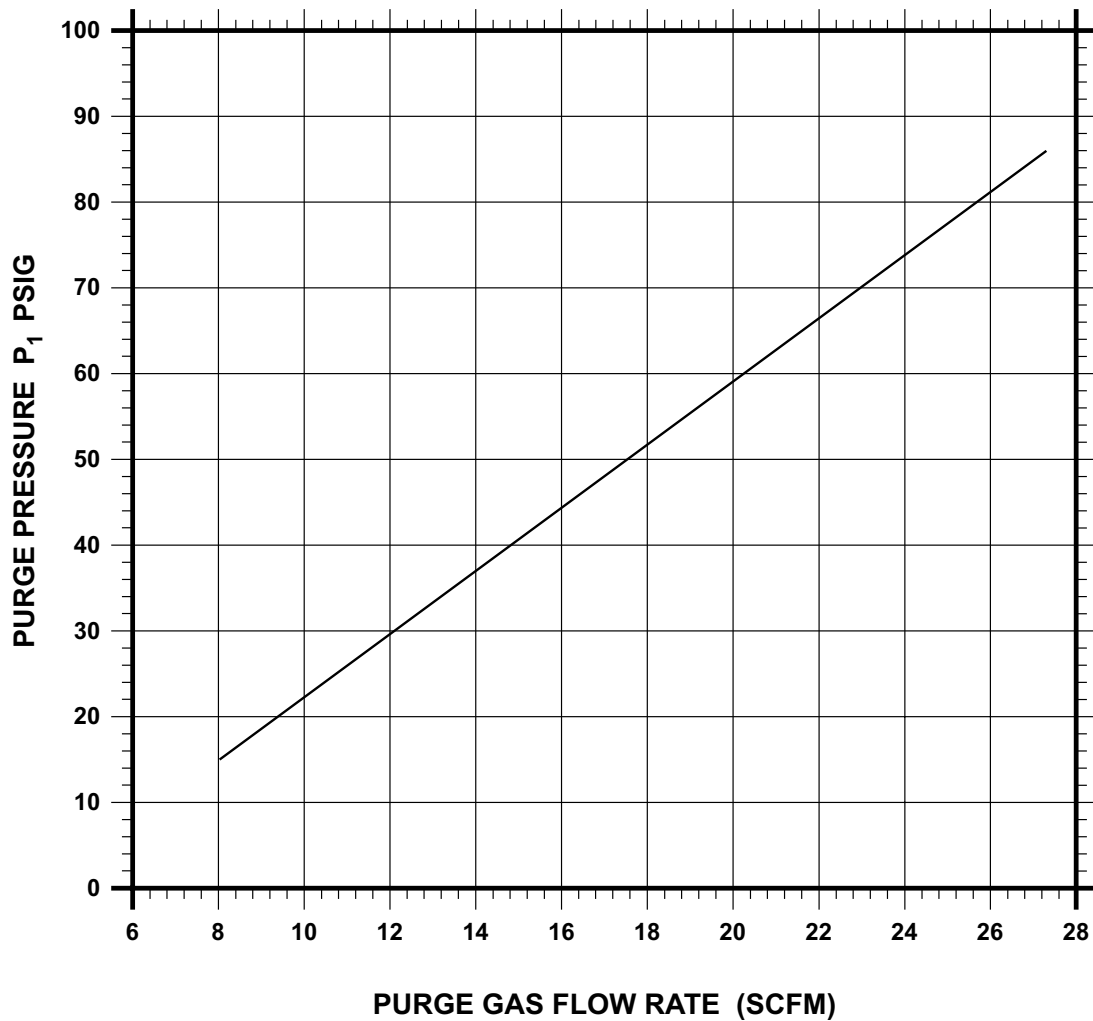
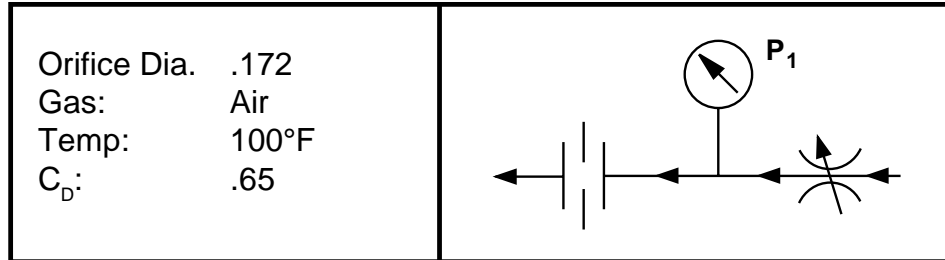
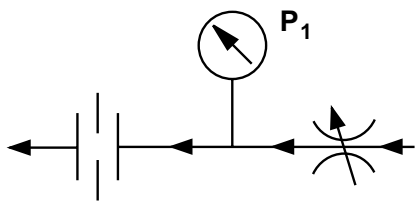

Figure A.3 — Critical Orifice Calibration Curve
(LS130)

HYDROBLOC LS SERIES PURGE CURVES

<p>Orifice Dia. .203 Gas: Air Temp: 100°F C_D: .65</p>	
--	--

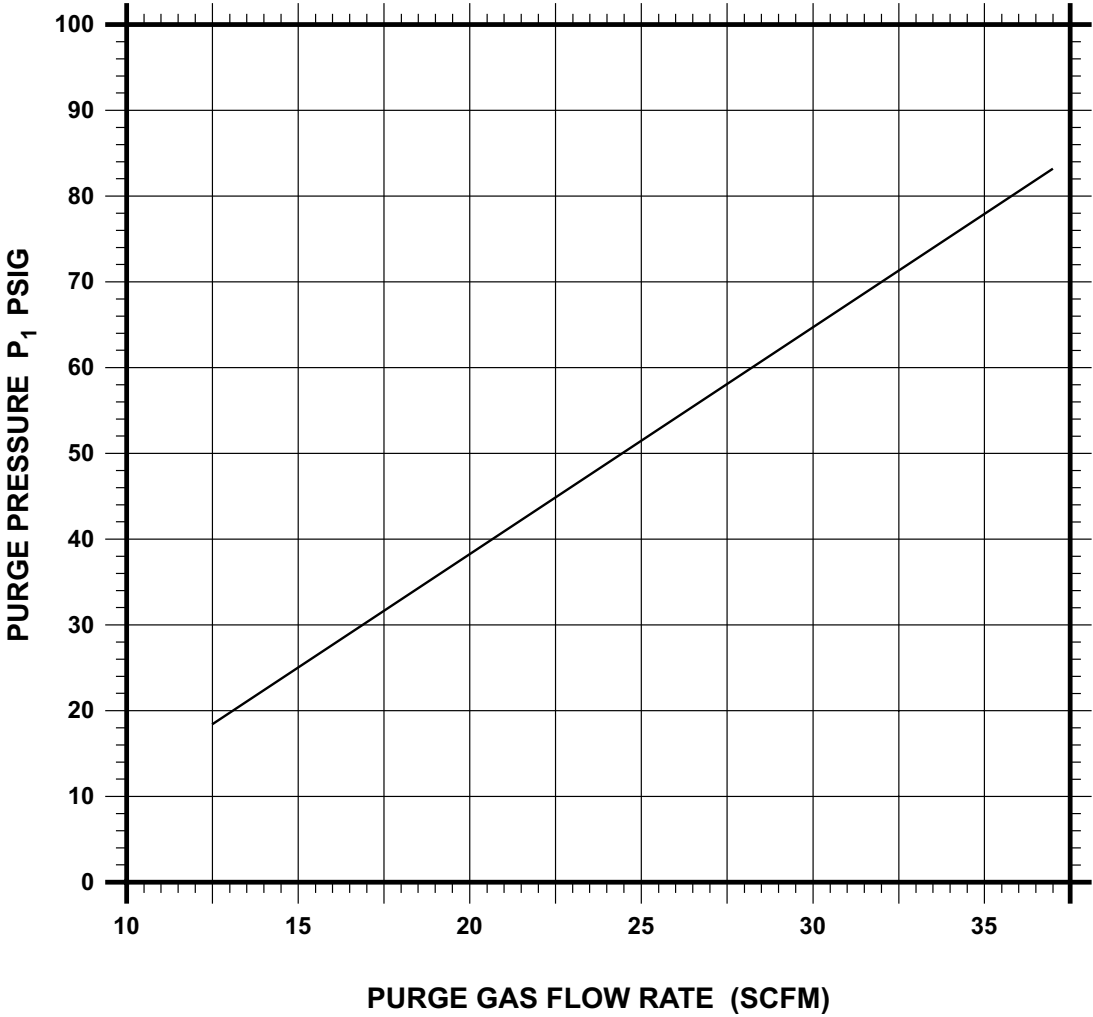

Figure A.4 — Critical Orifice Calibration Curve
(LS185)

HYDROBLOC LS SERIES PURGE CURVES

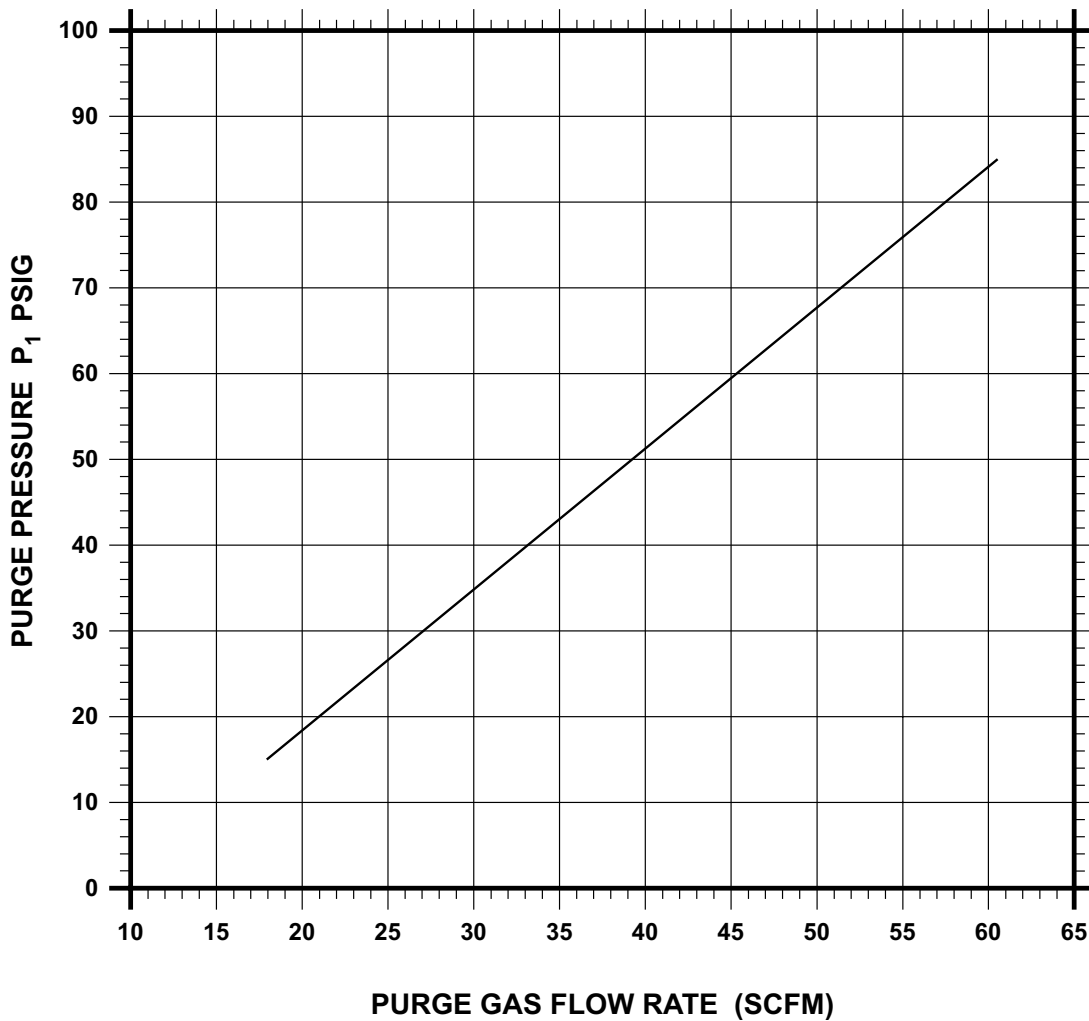
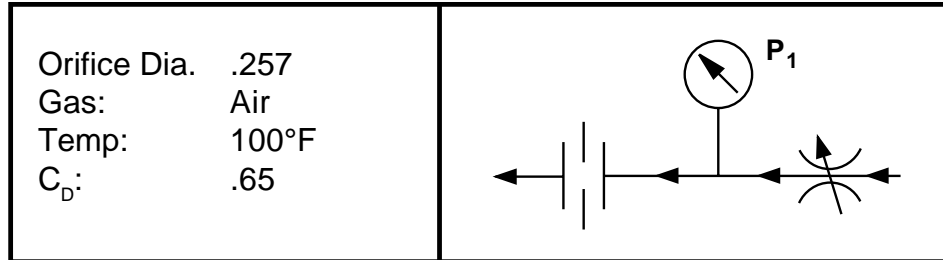

Figure A.5 — Critical Orifice Calibration Curve
(LS240)

HYDROBLOC LS SERIES PURGE CURVES

<p>Orifice Dia. .272 Gas: Air Temp: 100°F C_D: .65</p>	
---	--

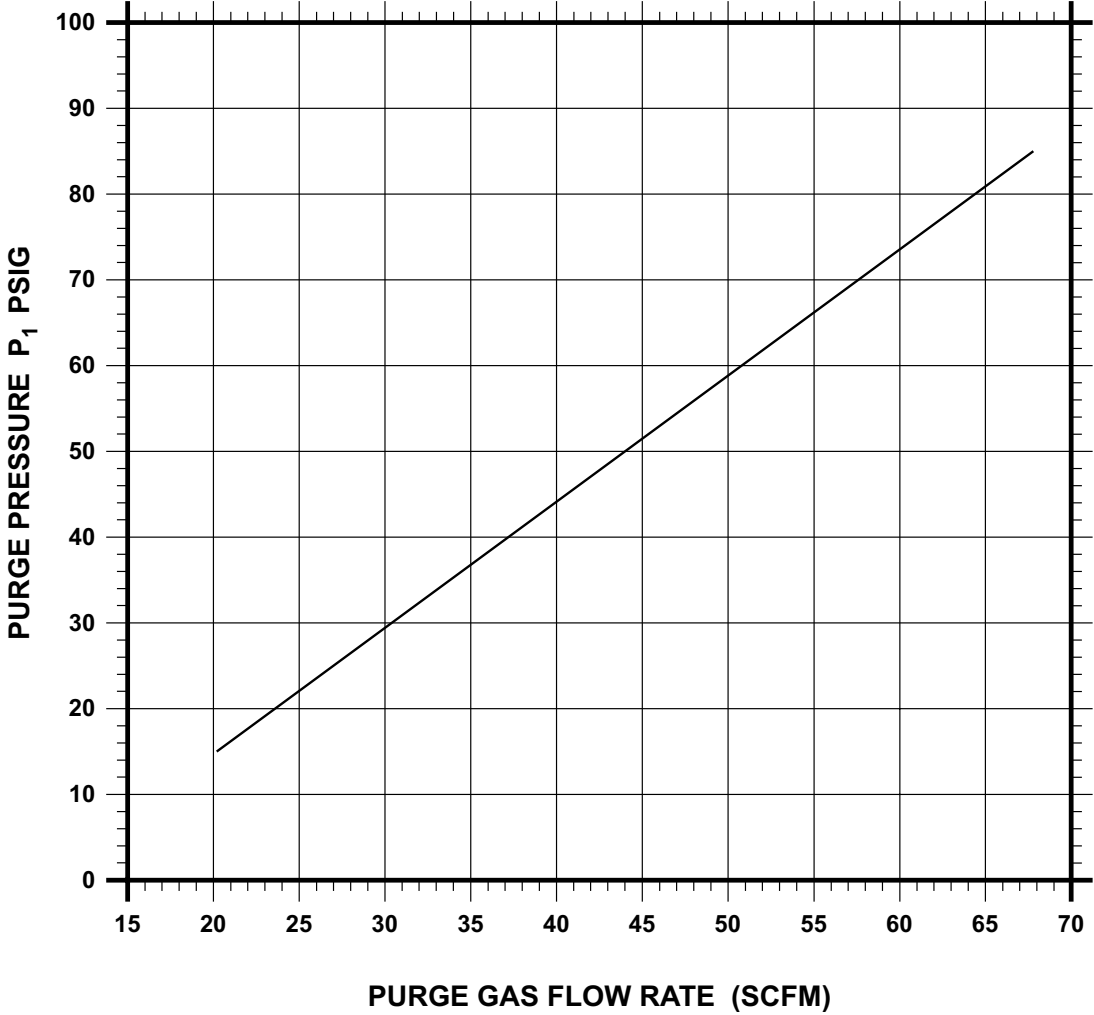

Figure A.6 — Critical Orifice Calibration Curve
(LS270)

HYDROBLOC LS SERIES PURGE CURVES

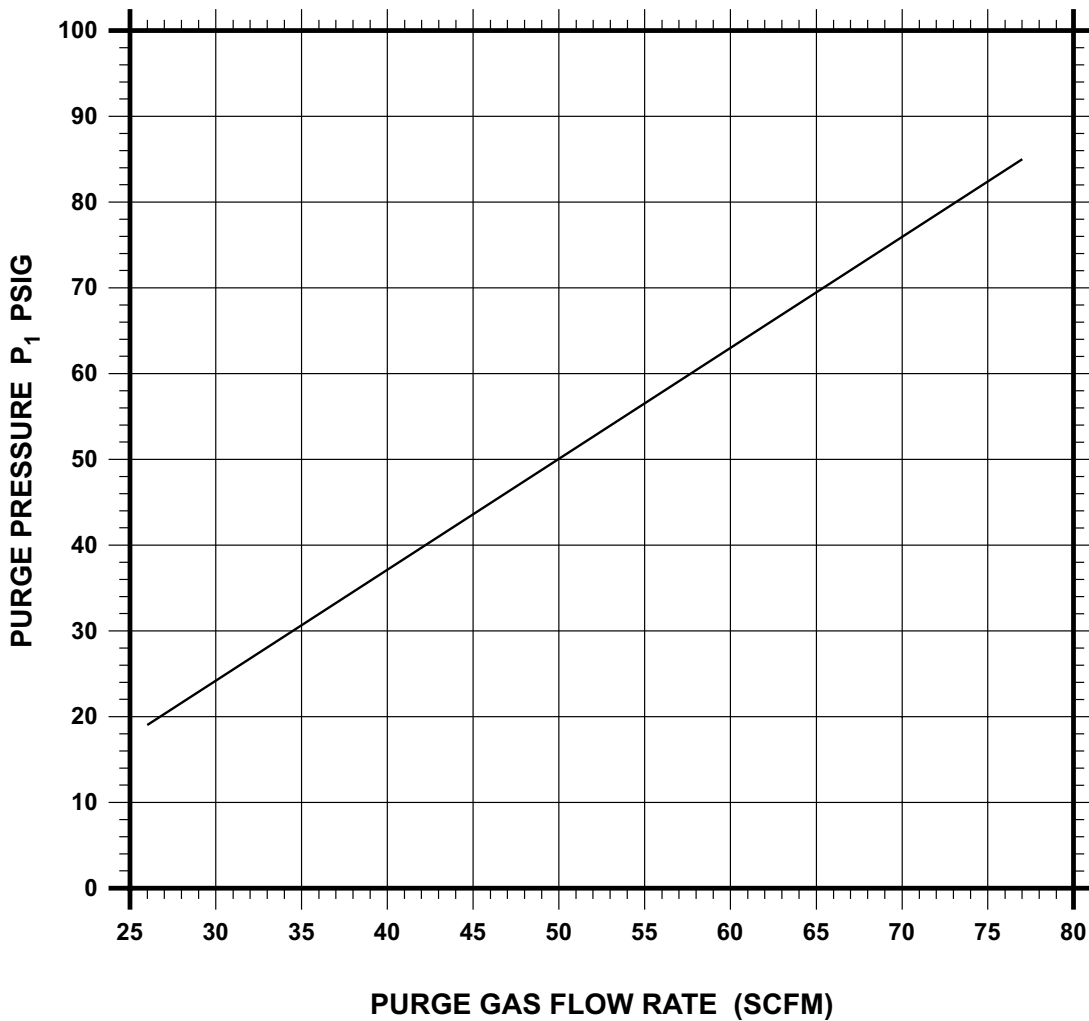
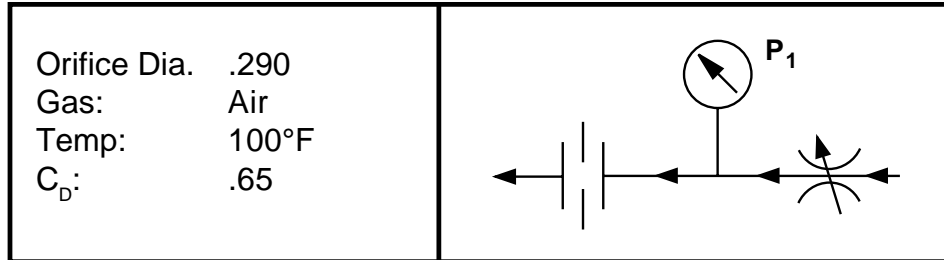
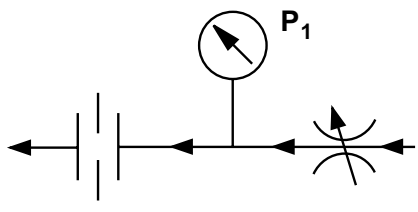

Figure A.7 — Critical Orifice Calibration Curve
(LS360)

HYDROBLOC LS SERIES PURGE CURVES

<p>Orifice Dia. .359 Gas: Air Temp: 100°F C_D: .65</p>	
---	--

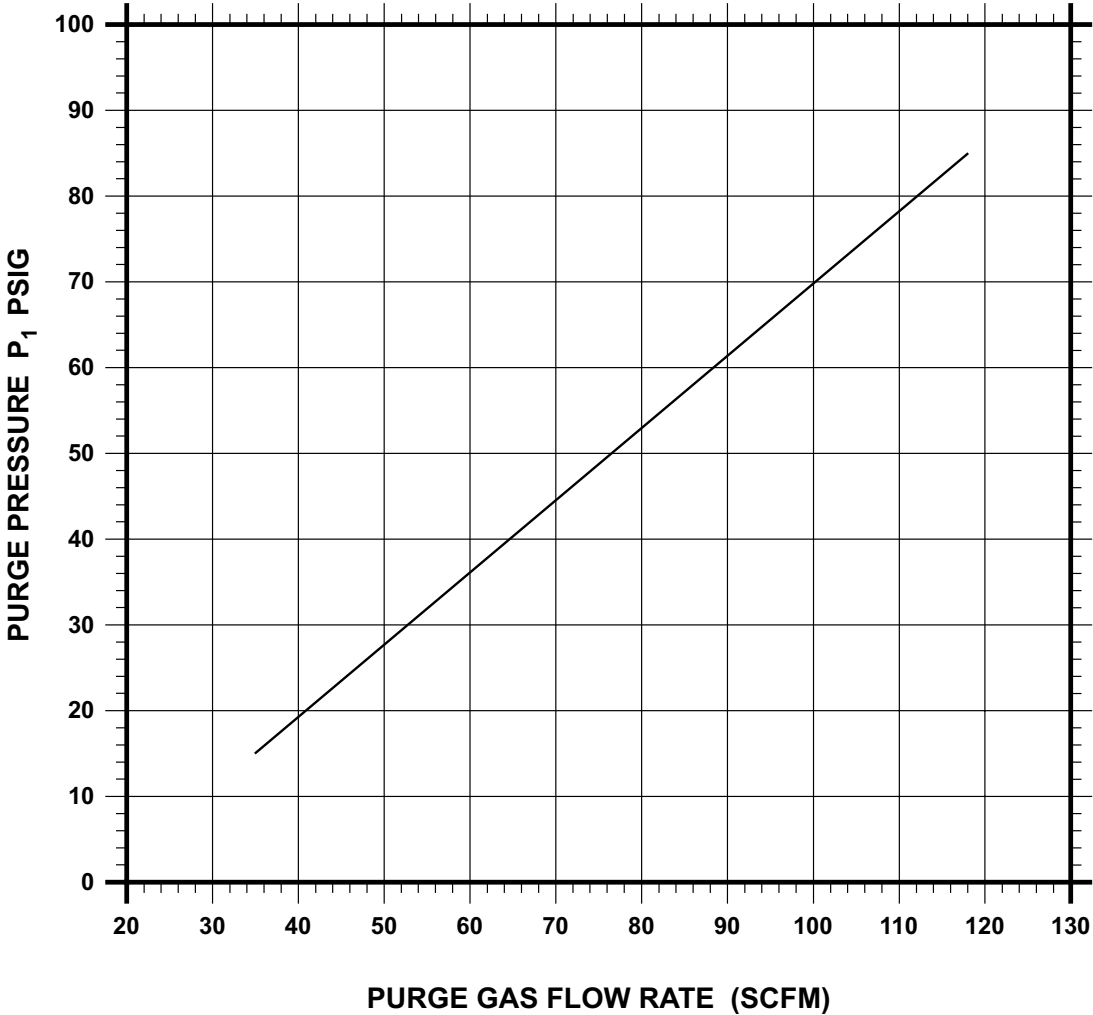

Figure A.8 — Critical Orifice Calibration Curve
(LS505)

HYDROBLOC LS SERIES PURGE CURVES

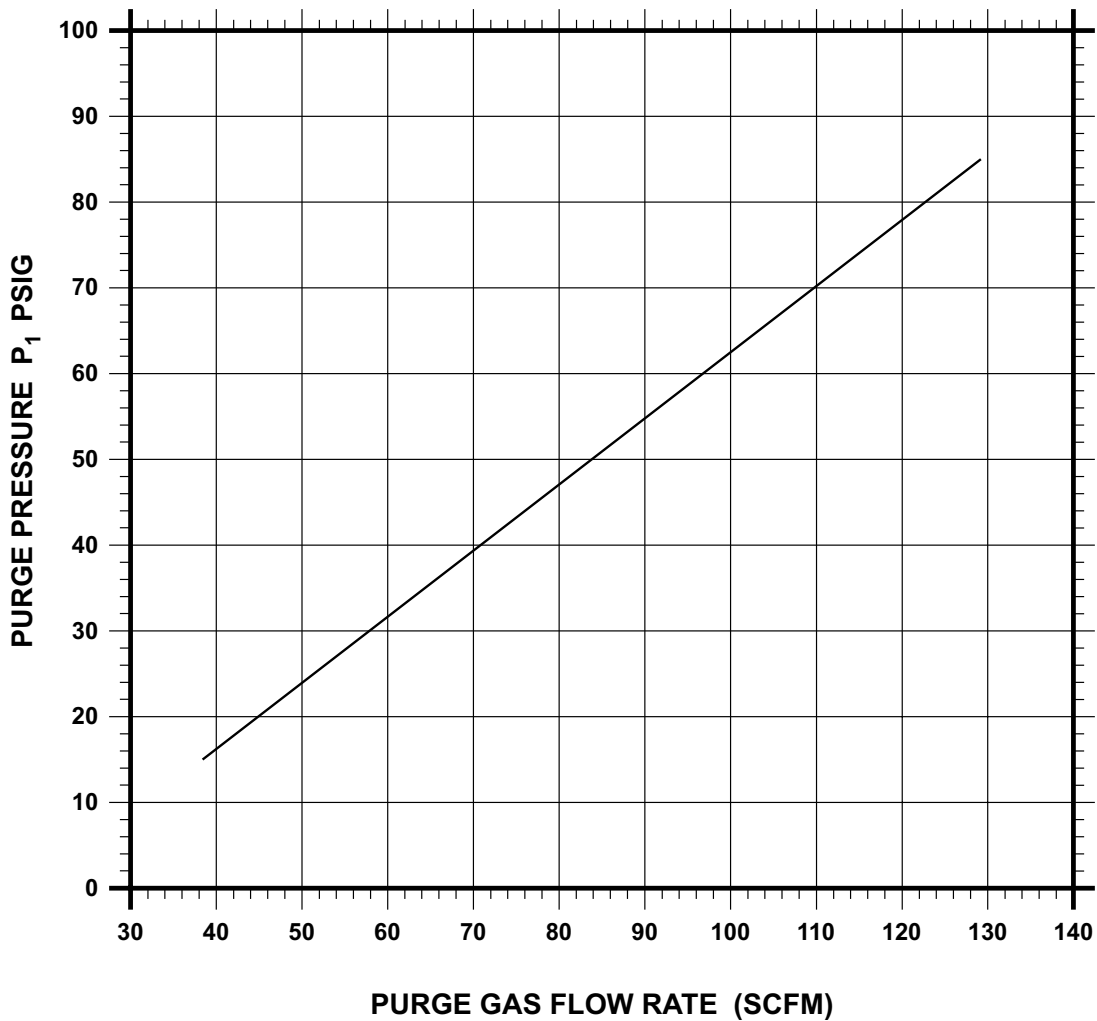
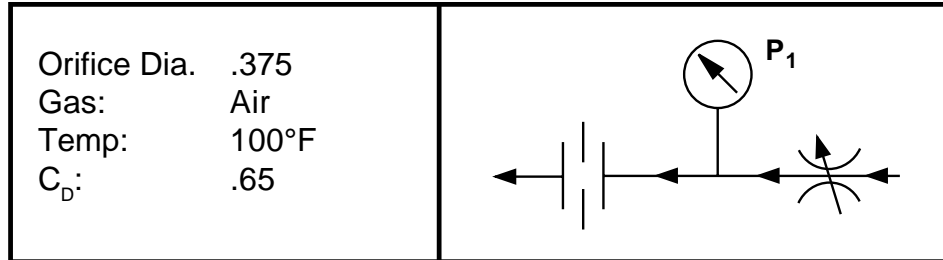

Figure A.9 — Critical Orifice Calibration Curve
(LS630)

HYDROBLOC LS SERIES PURGE CURVES

<p>Orifice Dia. .438 Gas: Air Temp: 100°F C_D: .65</p>	
--	--

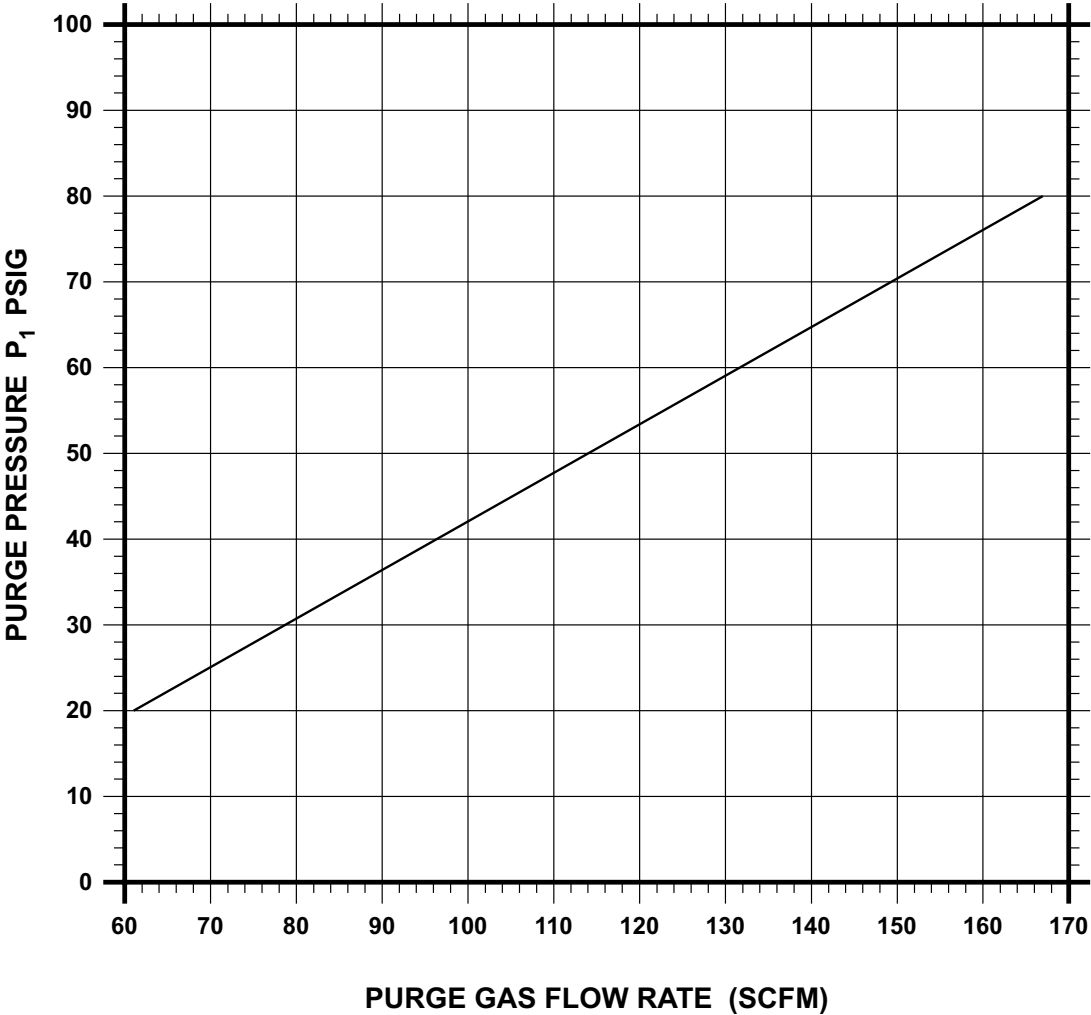

Figure A.10 — Critical Orifice Calibration Curve
(LS760)

HYDROBLOC LS SERIES PURGE CURVES

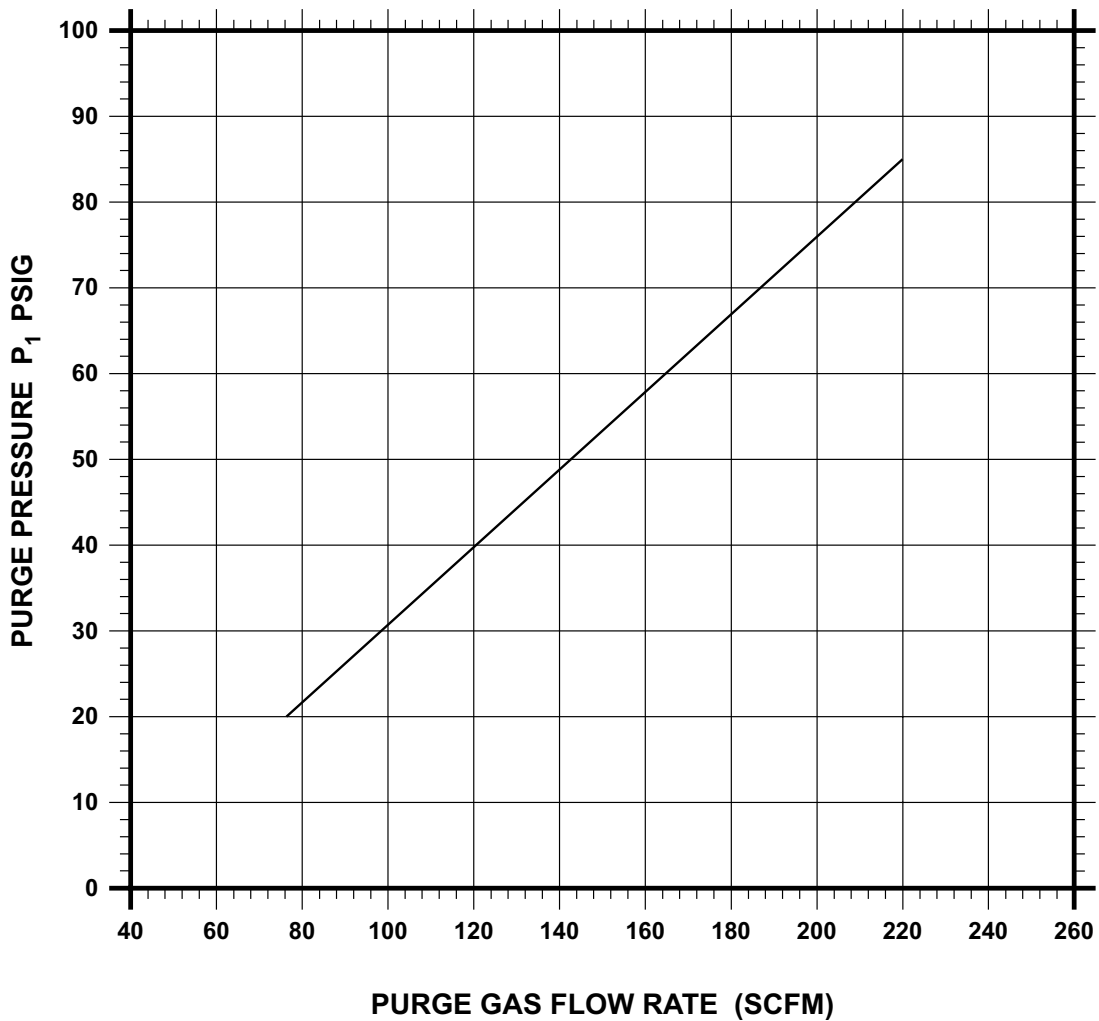
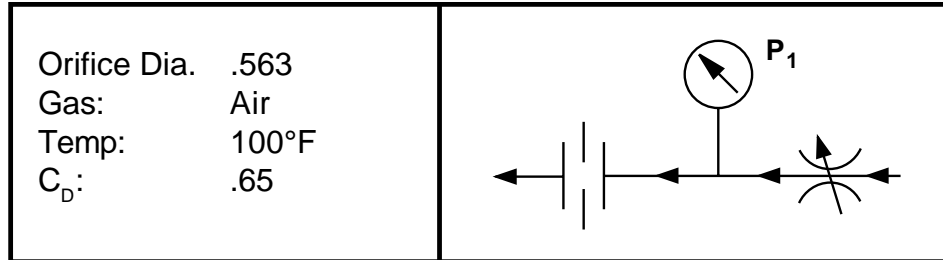

Figure A.11 — Critical Orifice Calibration Curve
(LS1000)

HYDROBLOC LS SERIES PURGE CURVES

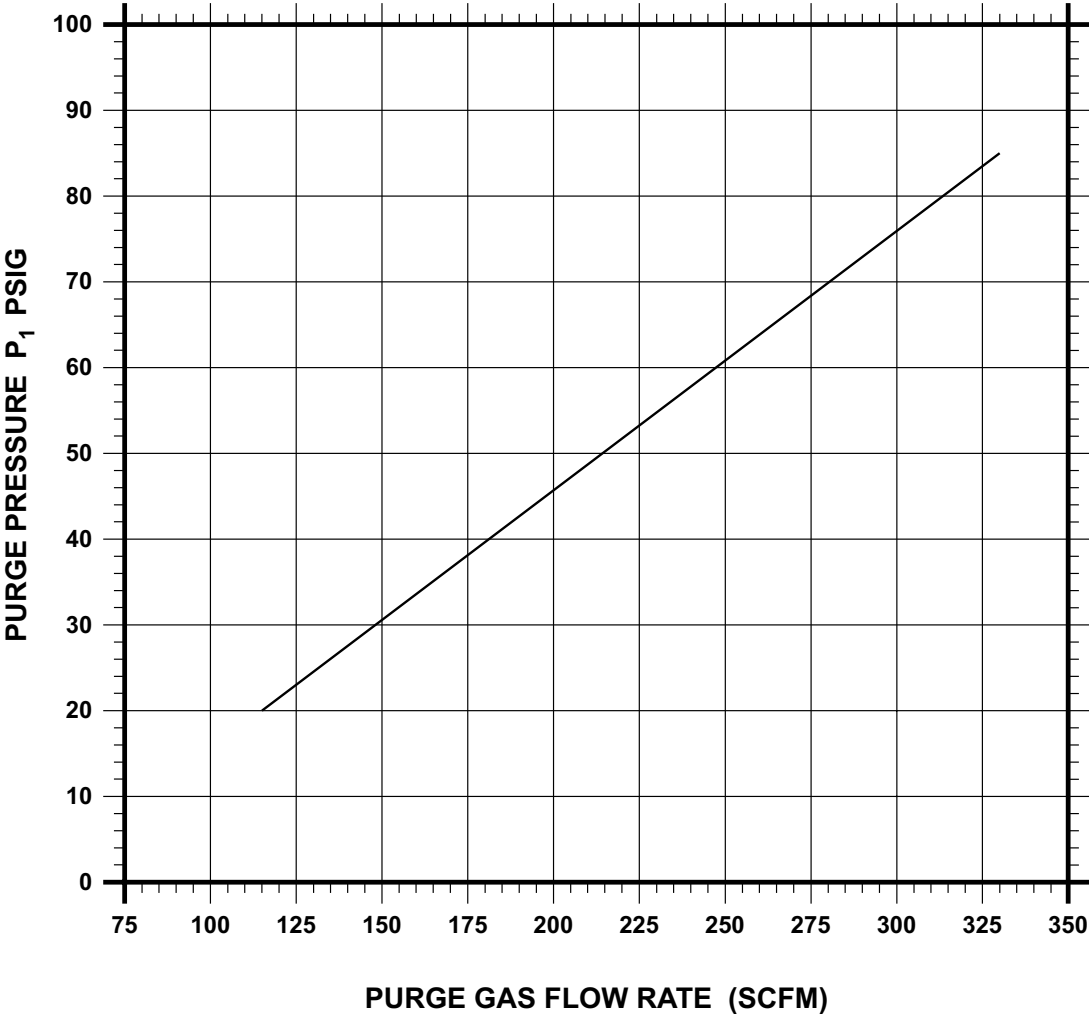
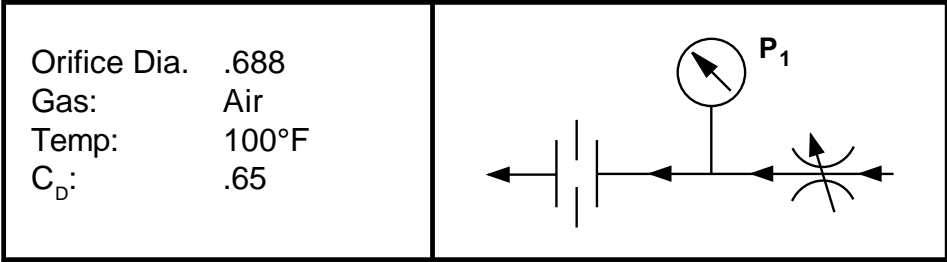

Figure A.12 — Critical Orifice Calibration Curve
(LS1250, LS1500)

HYDROBLOC LS SERIES PURGE CURVES

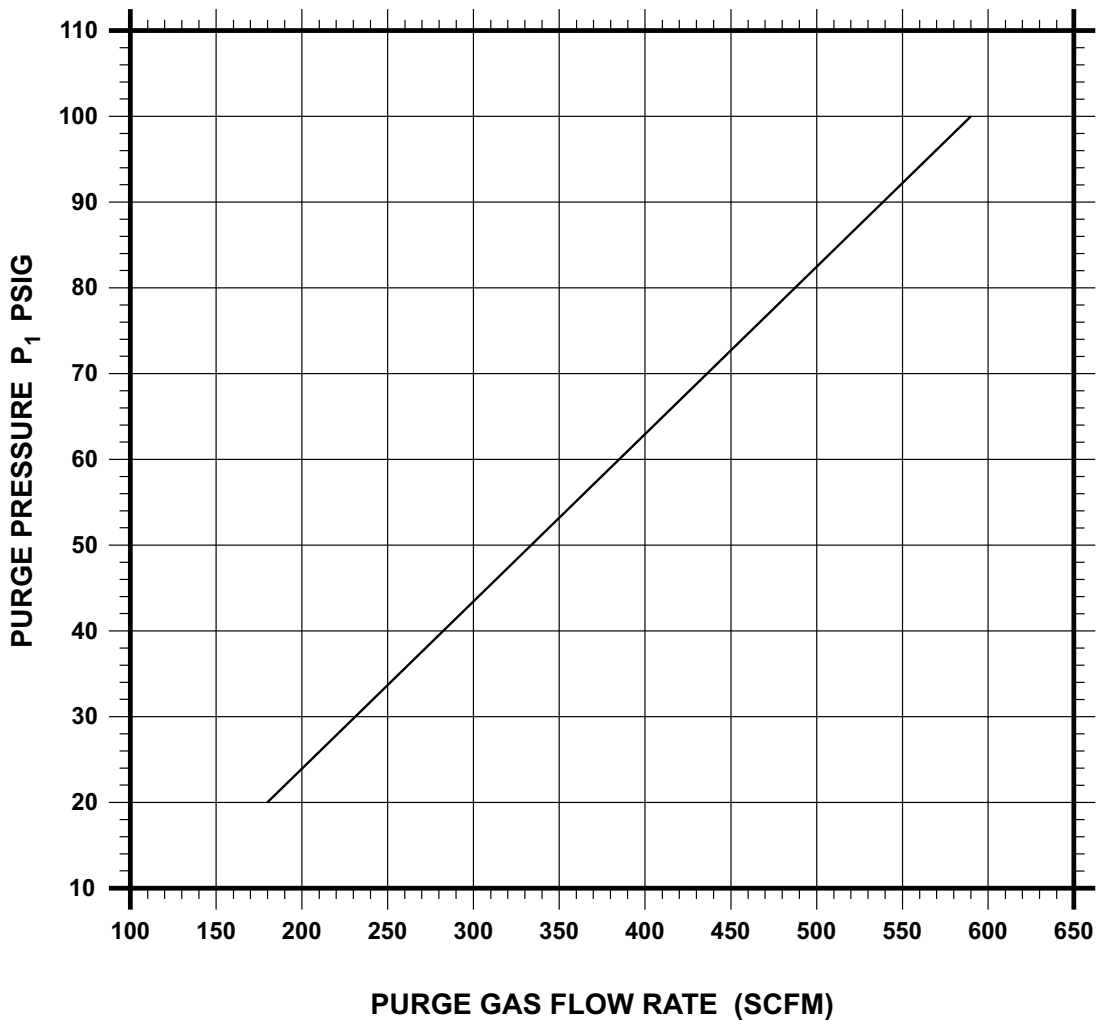
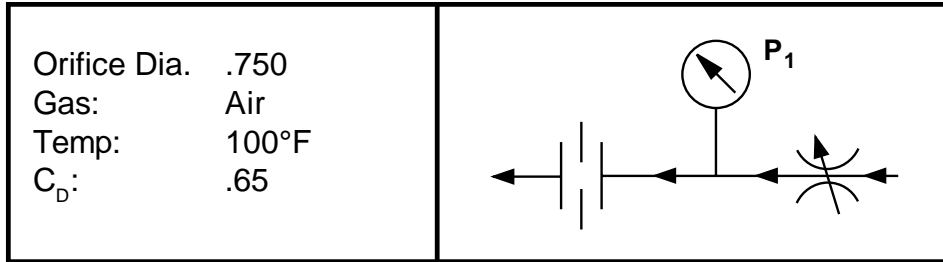

Figure A.13 — Critical Orifice Calibration Curve
(LS20700, LS2580)

Appendix B

Replacement Parts

HYDROBLOC LS REPLACEMENT PARTS

Description	Quantity Required*	Model LS60	Model LS110	Model LS130	Model LS185	Model LS240
Muffler	1	1283853	1283853	1283853	1283853	1283853
Relief Valve	1	1124704	1124704	1124704	1124704	1124704
Pressure Gauge	3	1125546	1125546	1125546	1125546	1125546
AQUADEX® Repair Kit	1	1207278	1207278	1207278	1207278	1207278
Inlet/Exhaust Valve Packing Kit	1	1283204	1283204	1283214	1283214	1283222
Purge Valve Packing Kit	1	1283207	1283207	1283207	1283207	1283233
Inlet/Exhaust Valve Repair Kit	1	1283203	1283203	1283213	1283213	1283221
Purge Valve Repair Kit	1	1283206	1283206	1283206	1283206	1283232
Purge Orifice	2	1218634	1180925	1180926	1198157	1218635
Solid State Controller	1	1275442	1275442	1275442	1275442	1275442
Solenoid Valve	2	1275475	1275475	1275475	1275475	1275475
Solenoid Coil	2	1284506	1284506	1284506	1284506	1284506
Control Board (CPU)	1	1274947	1274947	1274947	1274947	1274947
Programmed IC	1	1270702	1270702	1270702	1270702	1270702
Fuse (1/2AMP)	1	1222239	1222239	1222239	1222239	1222239
Power Supply	1	1261094	1261094	1261094	1261094	1261094
Solenoid Valve Spare	1	1276724	1276724	1276724	1276724	1276724
Display Panel Cable Assembly	1	1273367	1273367	1273367	1273367	1273367
Pressure Switch (Option 'A' & 'B')	1	1221910	1221910	1221910	1221910	1221910
Pressure Switch Cable Assy (Option 'A' and 'B')	1	1262602	1262602	1262602	1262602	1262602
Pilot Filter Replacement Element	1	1223259	1223259	1223259	1223259	1223259
Prefilter Replacement Element	1	1276841	1276851	1276851	1276857	1276857
Afterfilter Replacement Element	1	1276843	1276843	1276847	1276847	1276861
Automatic Drain Valve	1	1276741	1276741	1276741	1276741	1276741
Desiccant						
1269703, OPD-4-17-S, 17# container, (qty./dryer)				1		
1269704, OPD-4-34-S, 34# container, (qty./dryer)		2	3	3	5	6
1269705, OPD-4-150#, 150# container, (qty./dryer)						

* Quantity required indicates spares recommended for stocking and maintenance.

HYDROBLOC LS REPLACEMENT PARTS

Description	Quantity Required*	Model LS270	Model LS360	Model LS505	Model LS630	Model LS760
Muffler	1	1283853	1283853	1283285	1283285	1283285
Relief Valve	1	1124704	1124704	1124704	1124704	1124704
Pressure Gauge	3	1125546	1125546	1125546	1125546	1125546
AQUADEX® Repair Kit	1	1207278	1207278	1207278	1207278	1207278
Inlet/Exhaust Valve Packing Kit	1	1283225	1283225	1283227	1283229	1283231
Purge Valve Packing Kit	1	1283233	1283233	1283235	1283235	1283235
Inlet/Exhaust Valve Repair Kit	1	1283224	1283224	1283226	1283228	1283230
Purge Valve Repair Kit	1	1283232	1283232	1283234	1283234	1283234
Purge Orifice	2	1198854	1200806	1218638	1180920	1180921
Solid State Controller	1	1275442	1275442	1275442	1275442	1275442
Solenoid Valve	2	1275475	1275475	1275475	1275475	1275475
Solenoid Coil	2	1284506	1284506	1284506	1284506	1284506
Control Board (CPU)	1	1274947	1274947	1274947	1274947	1274947
Programmed IC	1	1270702	1270702	1270702	1270702	1270702
Fuse (1/2AMP)	1	1222239	1222239	1222239	1222239	1222239
Power Supply	1	1261094	1261094	1261094	1261094	1261094
Solenoid Valve Spare	1	1276724	1276724	1276724	1276724	1276724
Display Panel Cable Assembly	1	1273367	1273367	1273367	1273367	1273367
Pressure Switch (Option 'A' & 'B')	1	1221910	1221910	1221910	1221910	1221910
Pressure Switch Cable Assy (Option 'A' and 'B')	1	1262602	1262602	1262602	1262602	1262602
Pilot Filter Replacement Element	1	1223259	1223259	1223259	1223259	1223259
Prefilter Replacement Element	1	1276865	1276865	1276875	1276875	1276881
Afterfilter Replacement Element	1	1276861	1276869	1276871	1276885	1276885
Automatic Drain Valve	1	1276741	1276741	1276741	1276741	1276741
Desiccant						
1269703, OPD-4-17-S, 17# container, (qty./dryer)			1	1		
1269704, OPD-4-34-S, 34# container, (qty./dryer)		3		4	3	2
1269705, OPD-4-150#, 150# container, (qty./dryer)		1	2	2	3	4

* Quantity required indicates spares recommended for stocking and maintenance.

HYDROBLOC LS REPLACEMENT PARTS

Description	Quantity Required*	Model LS1000	Model LS1250	Model LS1500	Model LS2070	Model LS2580
Muffler	1	1283853	1283853	1283853	1283853	1283853
Relief Valve	1	1124704	1124704	1124704	1124704	1124704
Pressure Gauge	3	1125546	1125546	1125546	1125546	1125546
AQUADEX® Repair Kit	1	1207278	1207278	1207278	1207278	1207278
Inlet/Exhaust Valve Packing Kit	1	1272497				
Inlet Valve Packing Kit	2		1256169	1256169	1252986	1252985
Exhaust Valve Packing Kit	2		1256167	1256168	1252986	1252986
Outlet & Purge Check Valve Packing Kit	1	1256401	1256401	1256401		
Inlet/Exhaust Valve Repair Kit	1	1272489				
Inlet Valve Repair Kit	1		1256174	1256174		
Exhaust Valve Repair Kit	1		1256172	1256173		
Outlet Valve Repair Kit	1	1256413	1256413	1256413		
Purge Valve Repair Kit	1	1256415	1256415	1256415		
Flow Restrictor Repair Kit	1			1205911	1205911	1205911
Flow Restrictor Rebuild Kit	1			1205937	1205937	1205937
Purge Orifice	2	1183533	1210703	1210703		
Purge Orifice	1				1268843	1268843
Solid State Controller	1	1275442				
Solenoid Valve	2	1275475				
Solenoid Coil	2	1284506				
Control Board (CPU)	1	1274947	1274947	1274947	1274947	1274947
Programmed IC	1	1270702	1270702	1270702	1270702	1270702
Fuse (1/2AMP)	1	1222239	1222239	1222239	1222239	1222239
Power Supply	1	1261094	1261094	1261094	1261094	1261094
Solenoid Valve Spare	1	1276724	1276724	1276724	1276724	1276724
Display Panel Cable Assembly	1	1273367	1273367	1273367	1273367	1273367
Pressure Switch (Option 'A' & 'B')	1	1221910	1221910	1221910	1221910	1221910
Pressure Switch Cable Assy (Option 'A' and 'B')	1	1262602	1262602	1262602	1262602	1262602
Pilot Filter Replacement Element	1	1223259	1223259	1223259	1223259	1223259
Prefilter Replacement Element (qty./filter)		1276889 (1)	1276897 (1)	1276881 (2)	1276889 (2)	1276889 (3)
Afterfilter Replacement Element (qty./filter)		1276893 (1)	1276901 (1)	1276885 (2)	1276893 (2)	1276901 (3)
Automatic Drain Valve	1	1276741	1276741	1276741	1276741	1276741
Desiccant						
1269703, OPD-4-17-S, 17# container, (qty./dryer)						
1269704, OPD-4-34-S, 34# container, (qty./dryer)			1			
1269705, OPD-4-150#, 150# container, (qty./dryer)		1		2		
1269706, OPD-4-350#, 350# container, (qty./dryer)		2	3	3	5	2
1269707, OPD-4-2000#, 2000# container, (qty./dryer)						1
1269708, OPD-25-150#, 150# container, (qty./dryer)					1	2

* Quantity required indicates spares recommended for stocking and maintenance.

Appendix C

Specifications, Purge Curves and Replacement Parts for -100°F Pressure Dew Point Dryers

HYDROBLOC LSC SPECIFICATIONS

STANDARD DESIGN OPERATING CONDITIONS

MODEL	FLOW CAPACITY ¹ (scfm)
LSC60	36
LSC110	66
LSC130	78
LSC185	111
LSC240	144
LSC270	162
LSC360	216
LSC505	303
LSC630	378
LSC760	456
LSC1000	600
LSC1250	750
LSC1500	900
LSC2070	1242
LSC2580	1548

Operating Pressure	<u>60 psig</u> minimum
	<u>150 psig</u> maximum
Operating Temperature	<u>40° F</u> minimum
	<u>120° F</u> maximum
Inlet Moisture Content	<u>Saturated</u> (at specified inlet pressure)
Outlet Moisture Content	<u>-100</u> °F Dew Point @ line pressure

¹ Based on 100°F inlet air temperature and -100°F pressure dew point. Maximum recommended inlet temperature, 120°F. For capacity at inlet temperature higher than 100°F, consult your local distributor.

DETAIL SPECIFICATIONS:

Dryer Cycle:	NEMA Cycle	<u>4 minutes</u>
	Drying	<u>2 minutes</u>
	Regeneration	<u>2 minutes</u>
Dryer Adsorbent:	Type	<u>DE-4 Activated Alumina</u>
Pressure Vessels:	ASME Section VIII, DIV. 1 Stamped	
	Design Pressure	<u>175 psig (minimum)</u>
	Design Temperature	<u>450° F</u>
Dryer:	Operation	<u>Automatic</u>
	Pressure Drop	<u>.5 TO 5 psid @ 100 psig and 100° F</u>
	Purge Source	<u>Dryer Outlet</u>

UTILITIES:

Electrical:	NEMA Type	<u>NEMA 4X</u>
	Input	<u>115V, 60 HZ, 1 PH</u>
	Power Consumption	<u>40 WATTS</u>

HYDROBLOC LSC SPECIFICATIONS

MODEL	PREFILTER	AFTERFILTER
LSC60	D-0050-CF	D-0050-PF
LSC110	D-0100-CF	D-0100-PF
LSC130	D-0100-CF	D-0100-PF
LSC185	D-0175-CF	D-0100-PF
LSC240	D-0175-CF	D-0170-PF
LSC270	D-0175-CF	D-0170-PF
LSC360	D-0250-CF	D-0300-PF
LSC505	D-0400-CF	D-0300-PF
LSC630	D-0400-CF	D-0405-PF
LSC760	D-0600-CF	D-0510-PF
LSC1000	D-0750-CF	D-0850-PF
LSC1250	D-1000-CF	D-0850-CF
LSC1500	D-1500-CF	D-1500-PF
LSC2070	D-2000-CF	D-2000-PF
LSC2580	D-3000-CF	D-3000-PF

HYDROBLOC LSC PURGE CURVES

Calculation of Purge Pressure Setting

1. Determine air pressure (psig) at the dryer inlet.
2. Refer to Table C-1. Determine the inlet airflow for your model and inlet air pressure.
3. To calculate purge flow consumption on the critical orifice curve:

$$\frac{\text{Inlet Flow (SCFM)} \times 14.7 \text{ PSIG}}{\text{Inlet Pressure (PSIG)} + 14.7 \text{ PSIG}} \times 1.15 = \text{Purge (SCFM)}$$
4. Locate the Critical Orifice Calibration Curve that has been sized for your specific dryer model.
5. Cross the Purge Flow requirement calculated above to the same number on the Critical Orifice Calibration Curve. Follow this line vertically and then horizontally once intersection is made with the curve line to find the actual purge pressure setting.
6. Locate the Purge Adjusting Valve. Slowly rotate dryer's Purge Adjusting Valve until the Purge Pressure Indicator indicates the calculated purge pressure setting. (See following Note).

Note: The purge pressure can only be read and adjusted when an off-line desiccant chamber has de-pressurized for regeneration. (When the off-line chamber is pressurized, the Purge Pressure Indicator will read "system pressure".)

Table C - 1 Inlet Airflow at Various Inlet Air Pressures¹

Model	Inlet Air Pressure (psig)									
	60	70	80	90	100	110	120	130	140	150
	Average Inlet Airflow (scfm) ²									
LSC60	23	27	30	33	36	39	42	45	49	52
LSC110	43	49	54	60	66	72	78	83	89	95
LSC130	51	58	64	71	78	85	92	98	105	112
LSC185	72	82	92	101	111	121	130	140	150	159
LSC240	94	106	119	131	144	157	169	182	194	207
LSC270	106	120	134	148	162	176	190	204	218	233
LSC360	141	160	178	197	216	235	254	272	291	310
LSC505	197	224	250	277	303	329	356	382	409	435
LSC630	246	279	312	345	378	411	444	477	510	543
LSC760	297	337	376	416	456	496	536	575	615	655
LSC1000	391	443	495	548	600	652	705	757	809	862
LSC1250	488	554	619	685	750	815	881	946	1,012	1,077
LSC1500	586	665	743	822	900	978	1,057	1,135	1,214	1,292
LSC2070	809	917	1,025	1,134	1,242	1,350	1,459	1,567	1,675	1,783
LSC2580	1,008	1,143	1,278	1,413	1,548	1,683	1,818	1,953	2,088	2,223

¹ Maximum inlet air pressure, 150 psig.

² Based on 100°F inlet air temperature and -100°F pressure dew point. Maximum recommended inlet temperature, 120°F. For capacity at inlet temperature higher than 100°F, consult your local distributor.

HYDROBLOC LSC PURGE CURVES

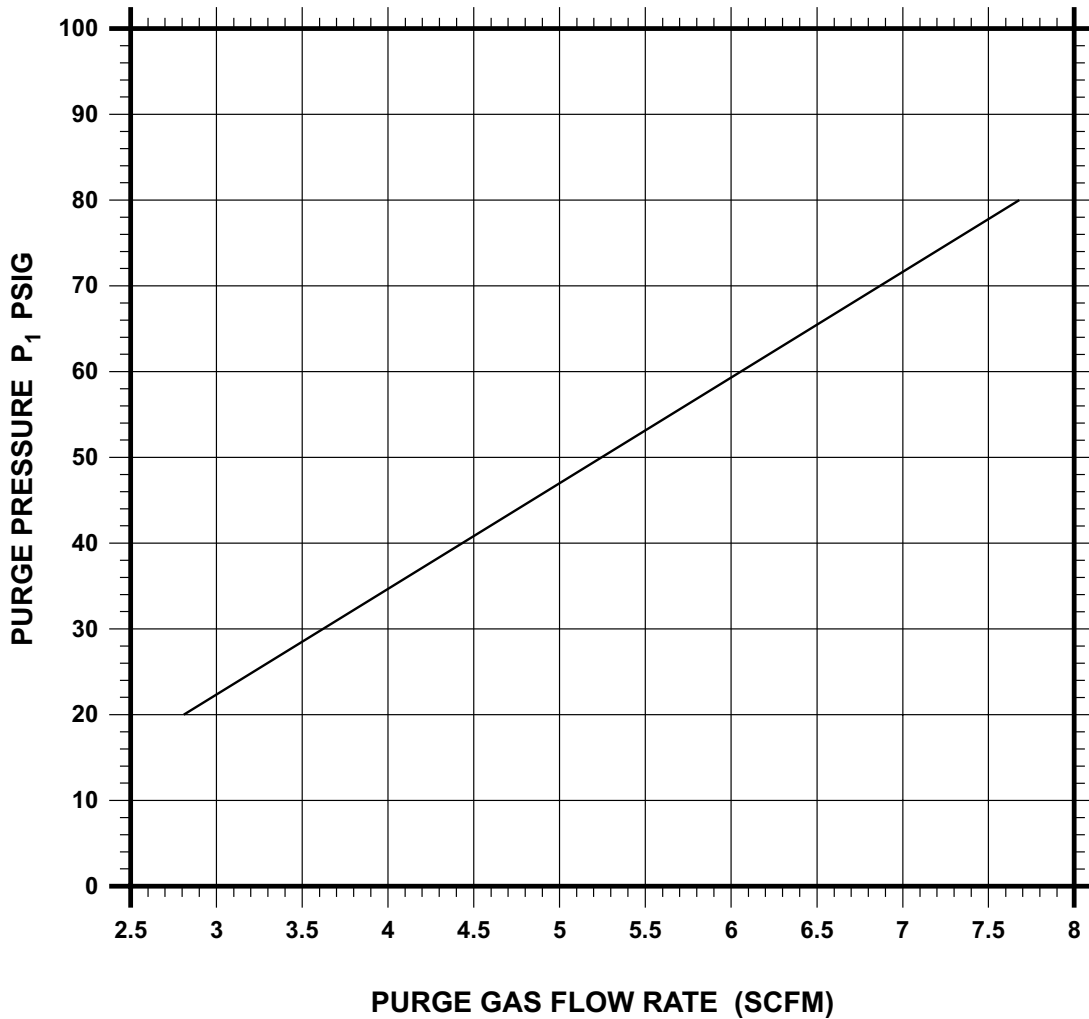
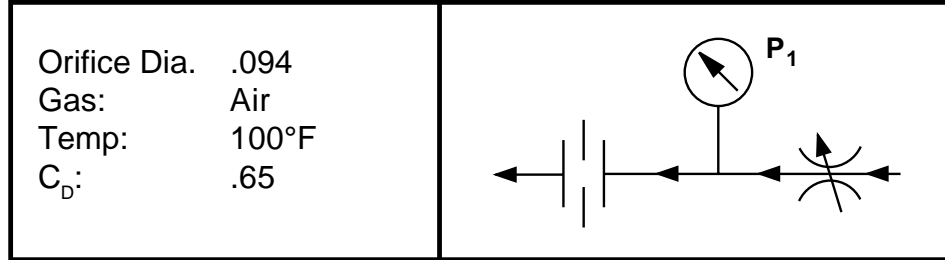

Figure C.1 — Critical Orifice Calibration Curve
(LSC60)

HYDROBLOC LSC PURGE CURVES

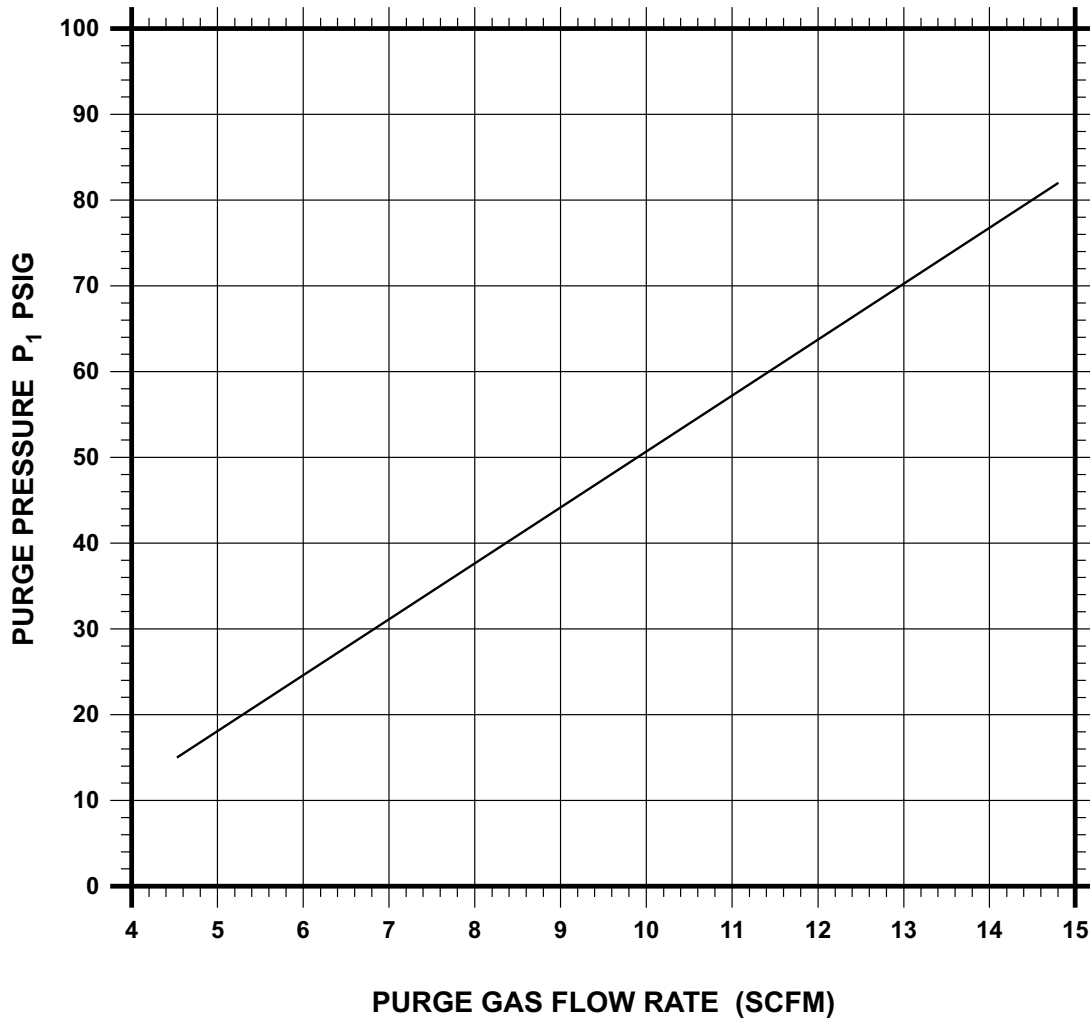
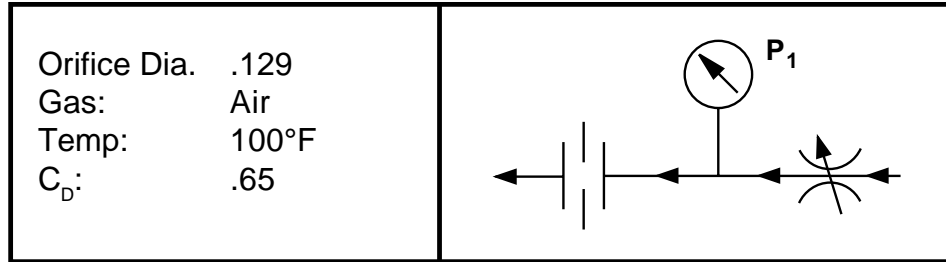
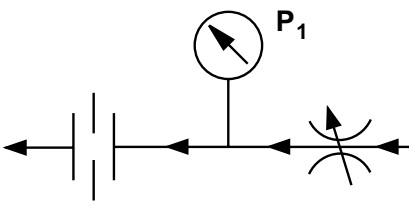

Figure C.2 — Critical Orifice Calibration Curve
(LSC110)

HYDROBLOC LSC PURGE CURVES

<p>Orifice Dia. .156 Gas: Air Temp: 100°F C_D: .65</p>	
--	--

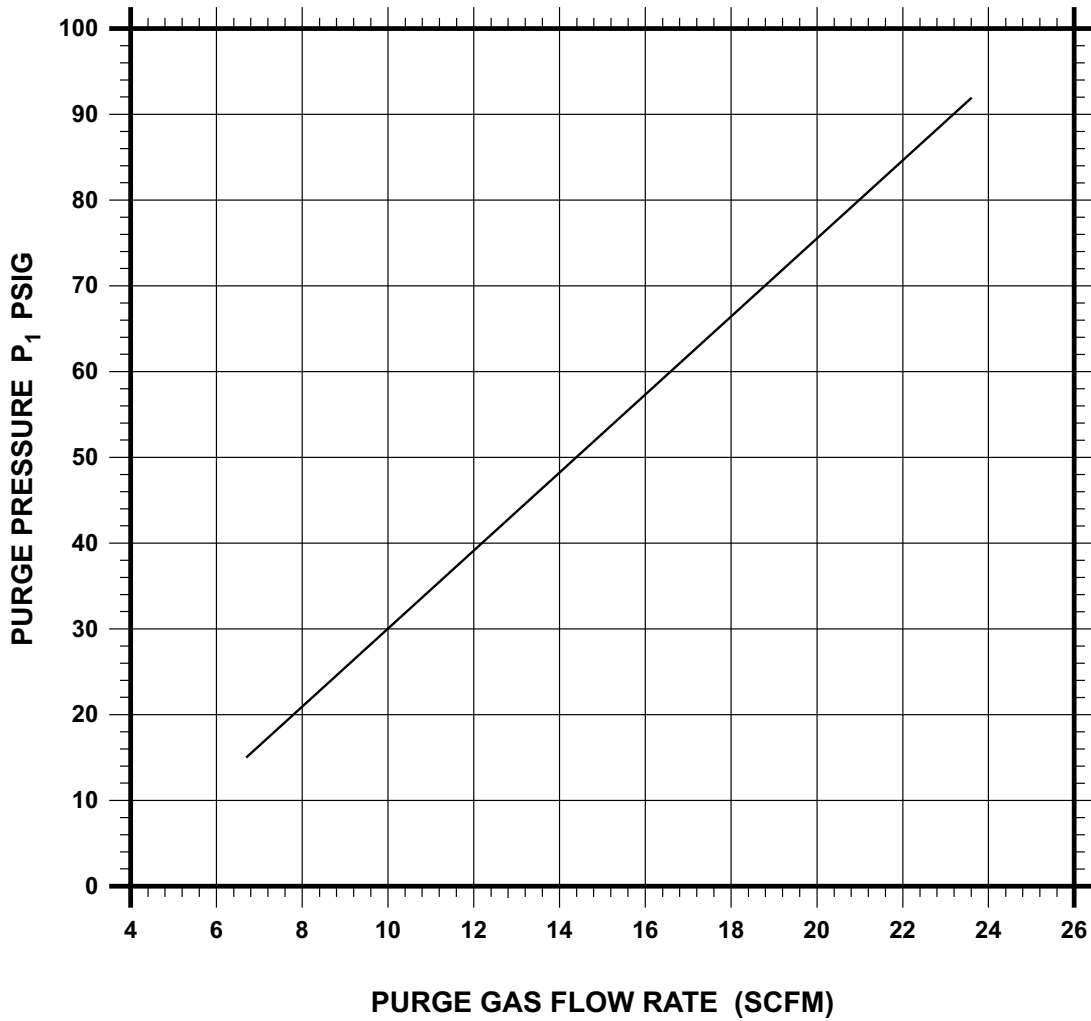

Figure C.3 — Critical Orifice Calibration Curve
(LSC130)

HYDROBLOC LSC PURGE CURVES

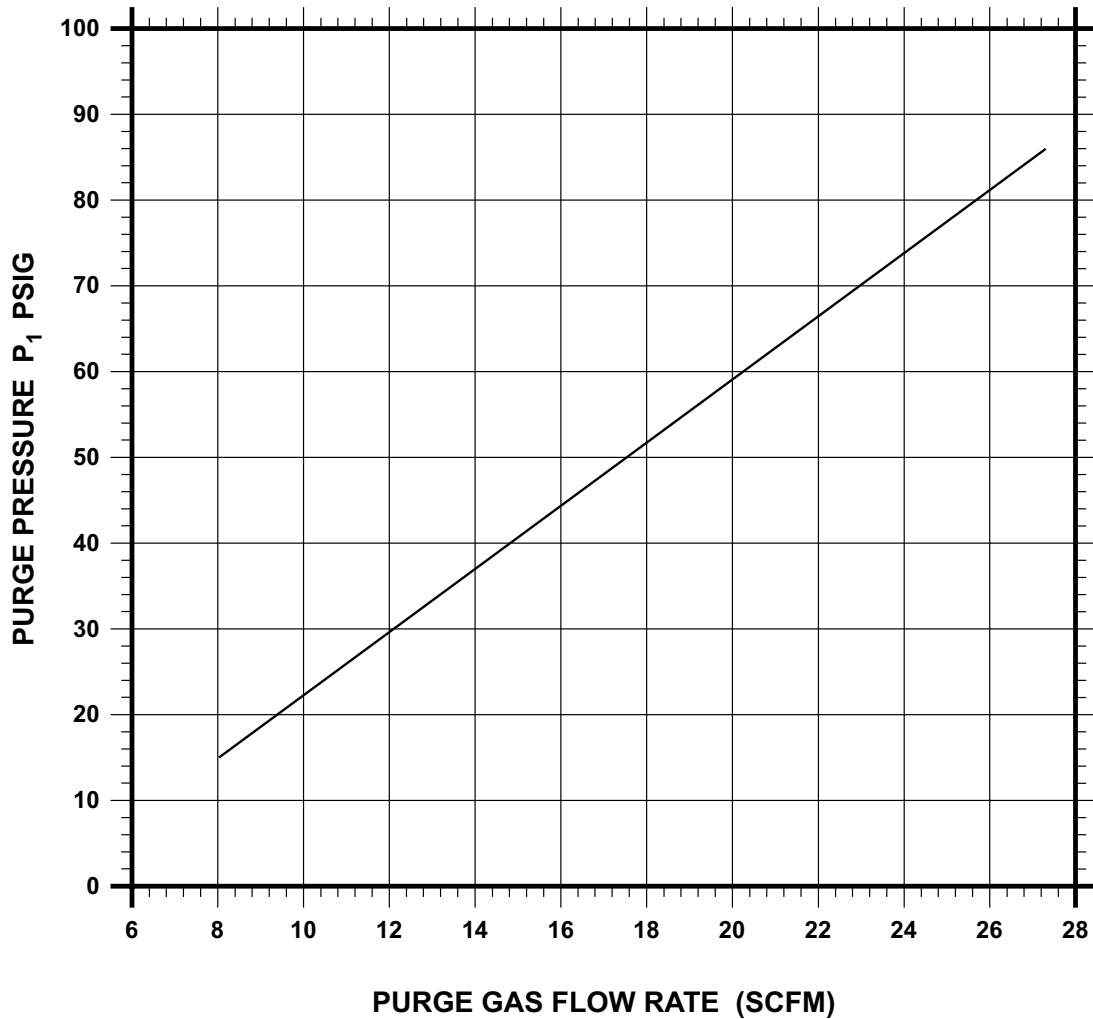
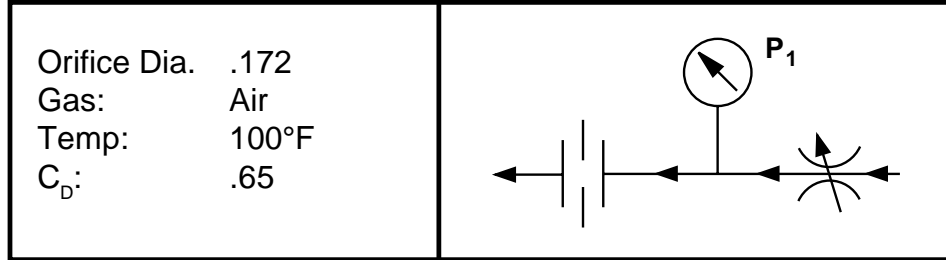
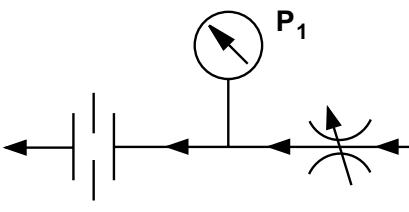

Figure C.4 — Critical Orifice Calibration Curve
(LSC185)

HYDROBLOC LSC PURGE CURVES

<p>Orifice Dia. .203 Gas: Air Temp: 100°F C_D: .65</p>	
--	--

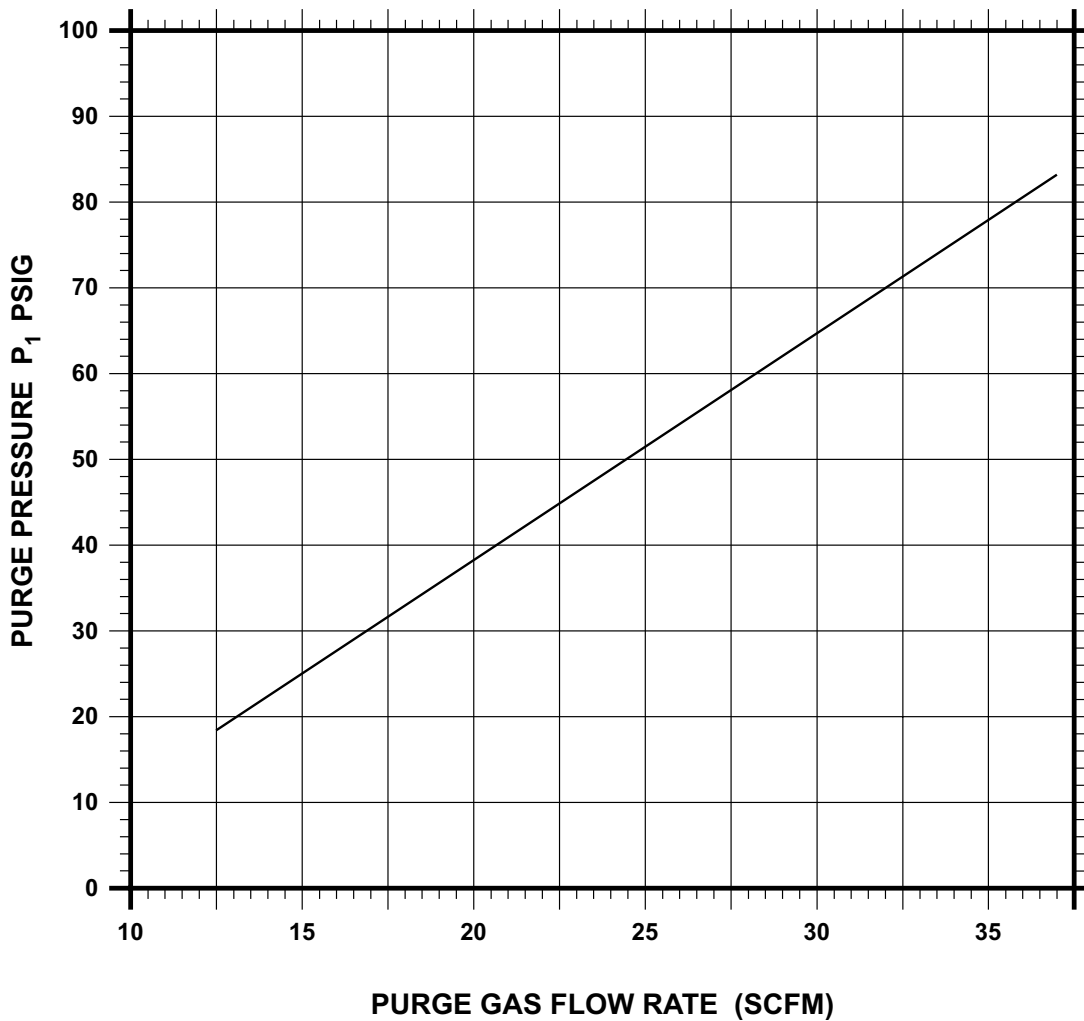

Figure C.5 — Critical Orifice Calibration Curve
 (LSC240, LSC270)

HYDROBLOC LSC PURGE CURVES

<p>Orifice Dia. .257 Gas: Air Temp: 100°F C_D: .65</p>	
---	--

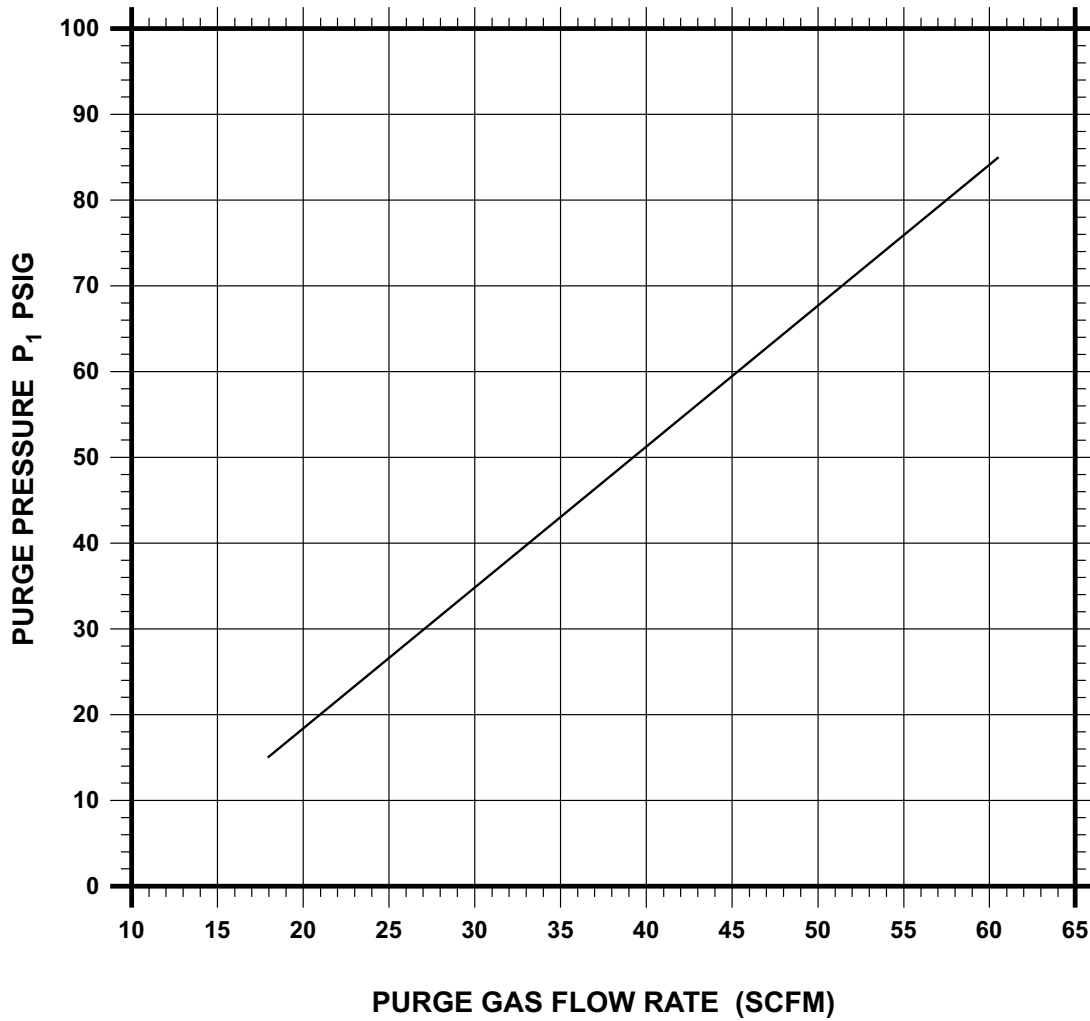

Figure C.6 — Critical Orifice Calibration Curve
(LSC360)

HYDROBLOC LSC PURGE CURVES

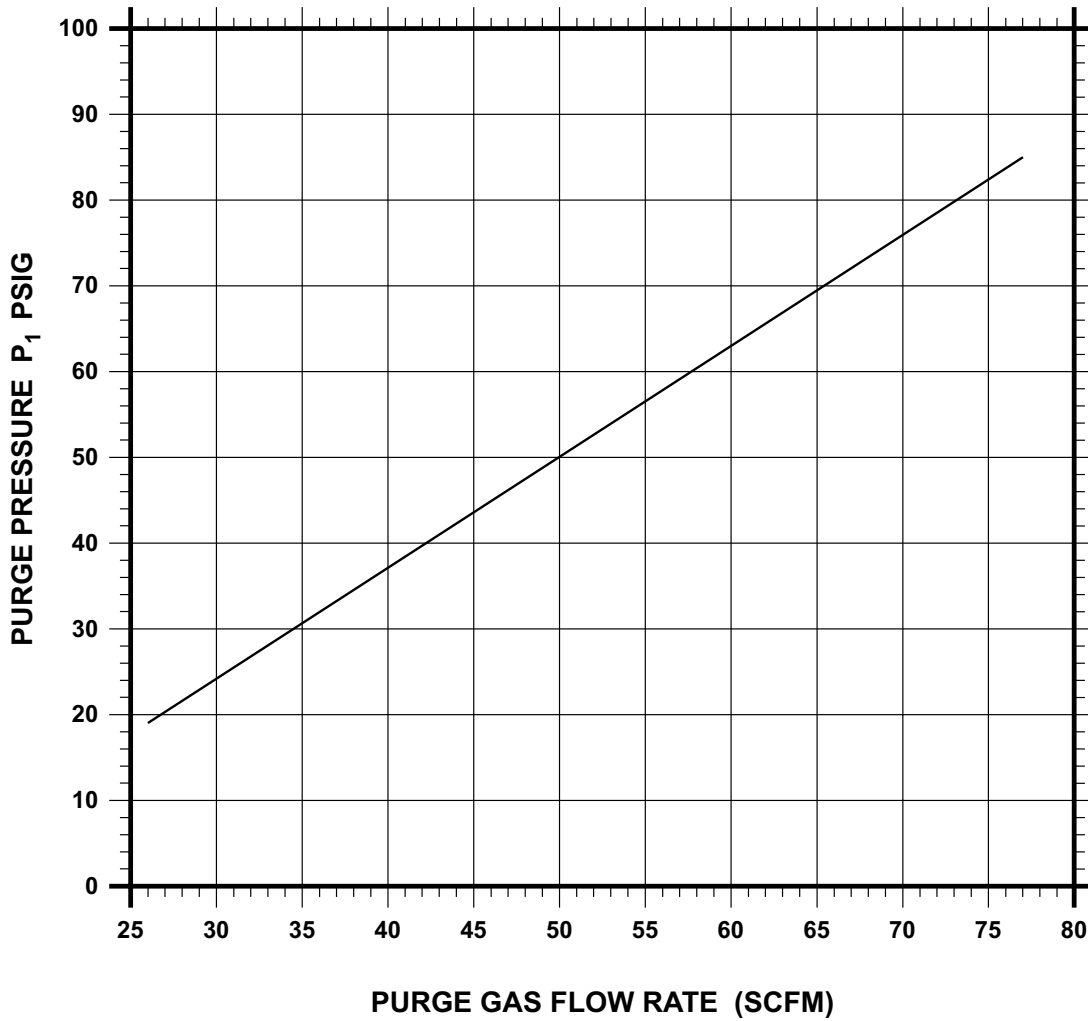
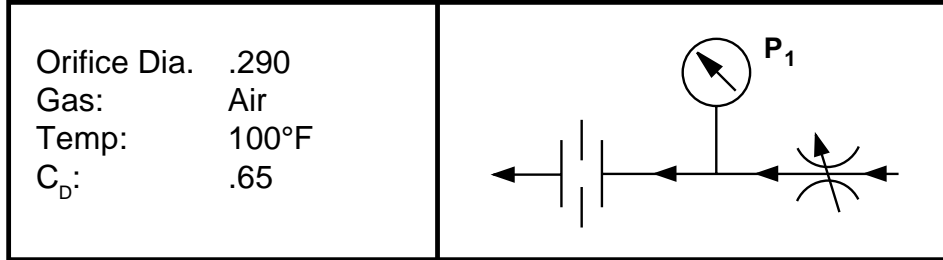

Figure C.7 — Critical Orifice Calibration Curve
(LSC505)

HYDROBLOC LSC PURGE CURVES

<p>Orifice Dia. .313 Gas: Air Temp: 100°F C_D: .65</p>	
--	--

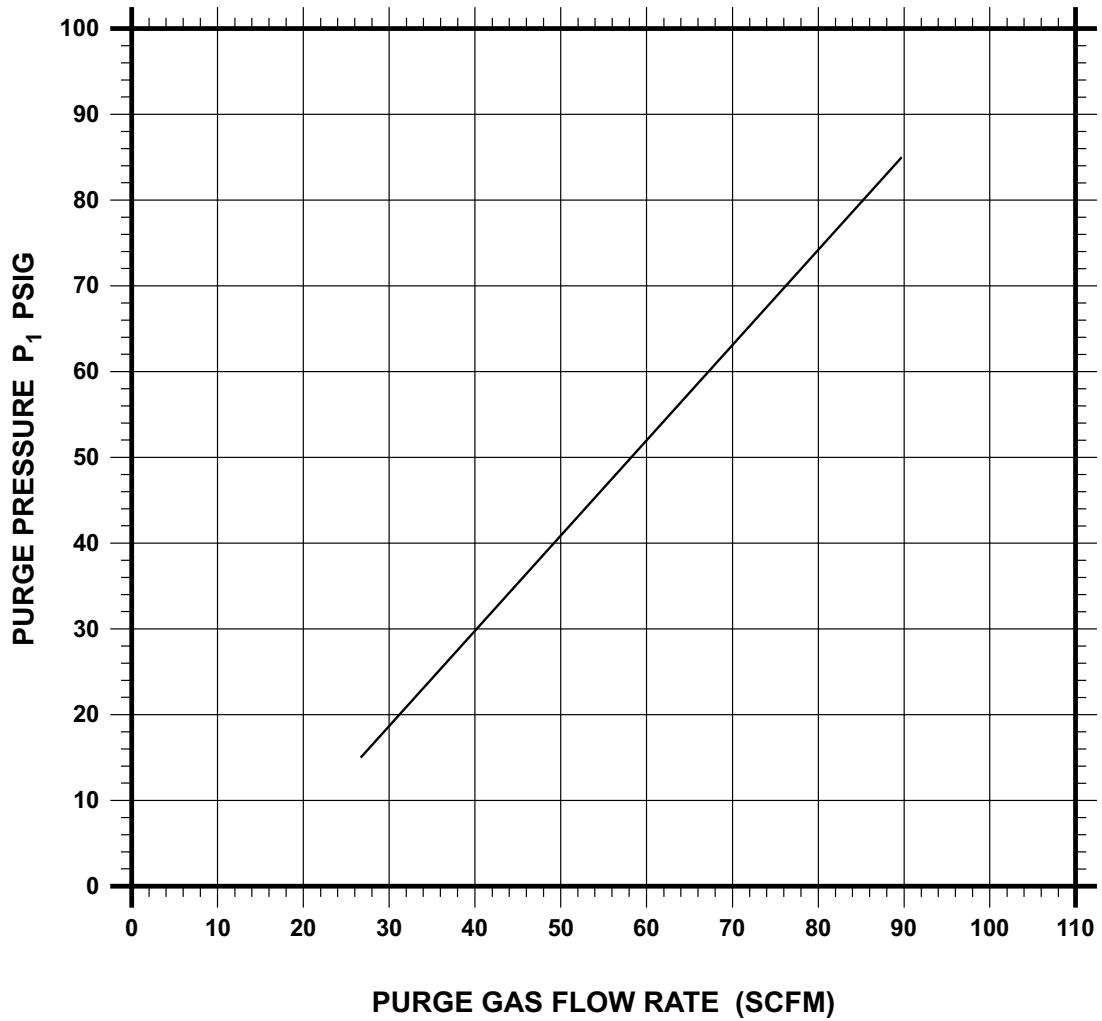

Figure C.8 — Critical Orifice Calibration Curve
(LSC630)

HYDROBLOC LSC PURGE CURVES

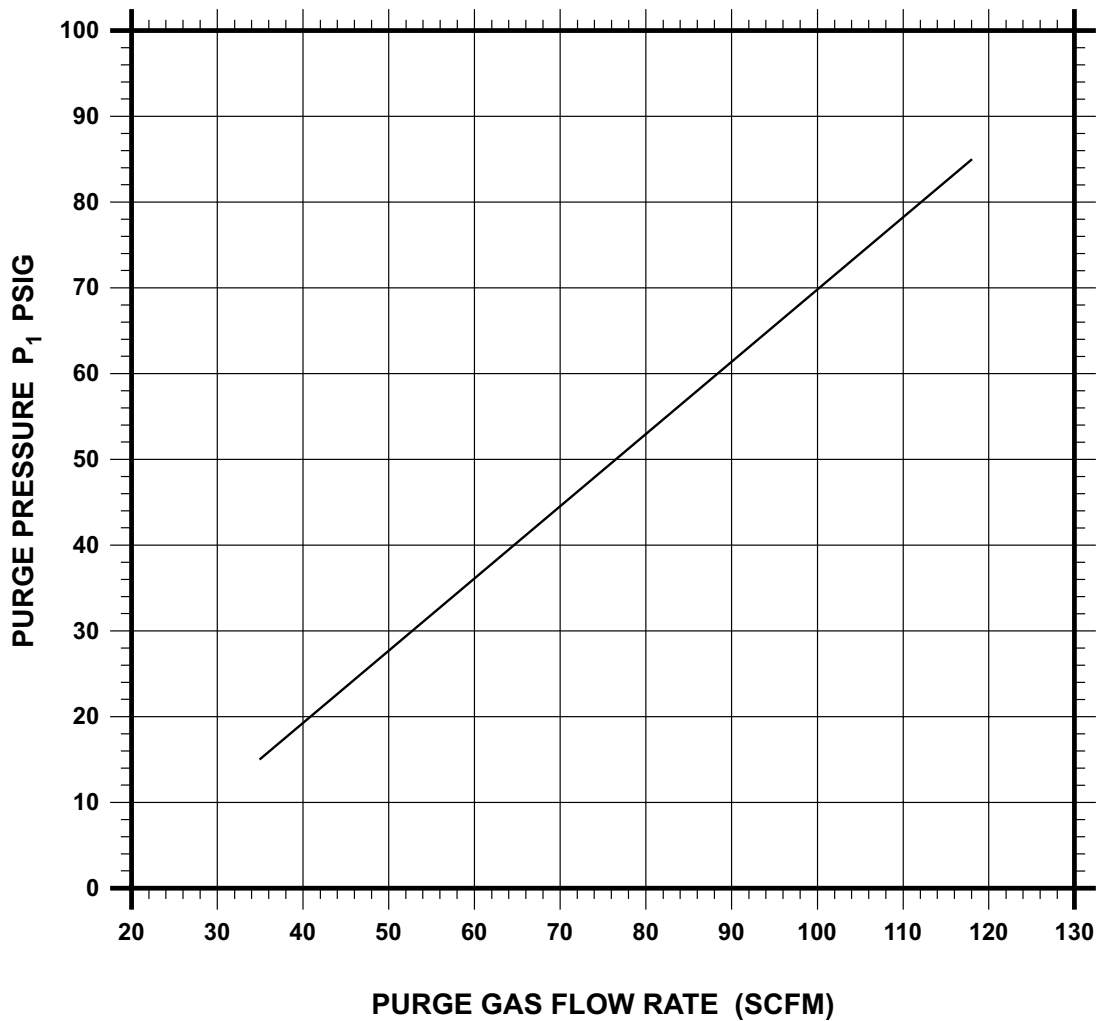
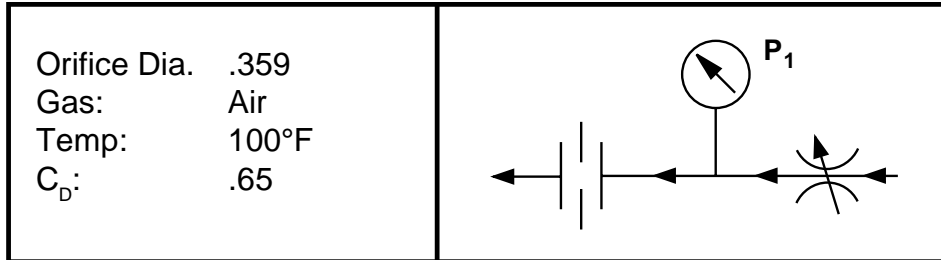

Figure C.9 — Critical Orifice Calibration Curve
(LSC760)

HYDROBLOC LSC PURGE CURVES

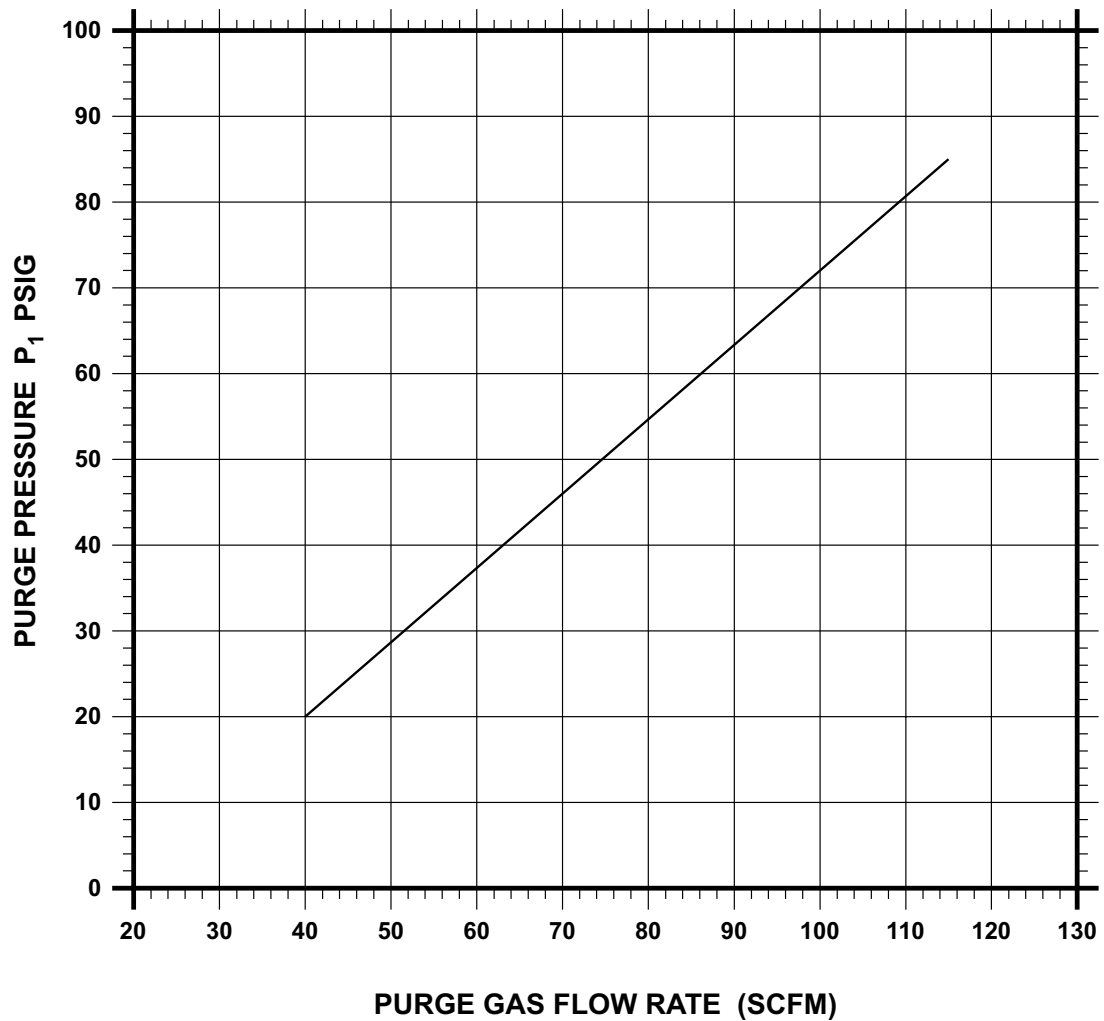
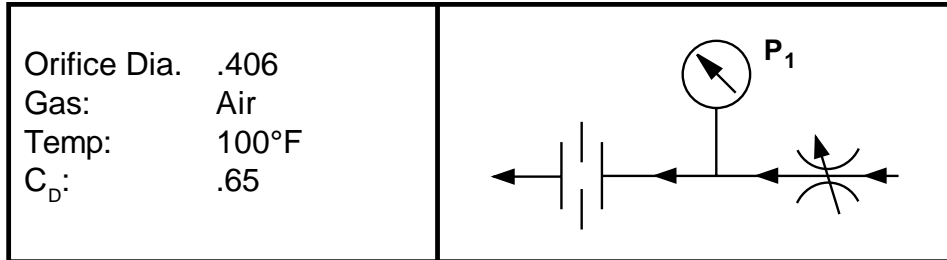

Figure C.10 — Critical Orifice Calibration Curve
(LSC1000, LSC1250)

HYDROBLOC LSC PURGE CURVES

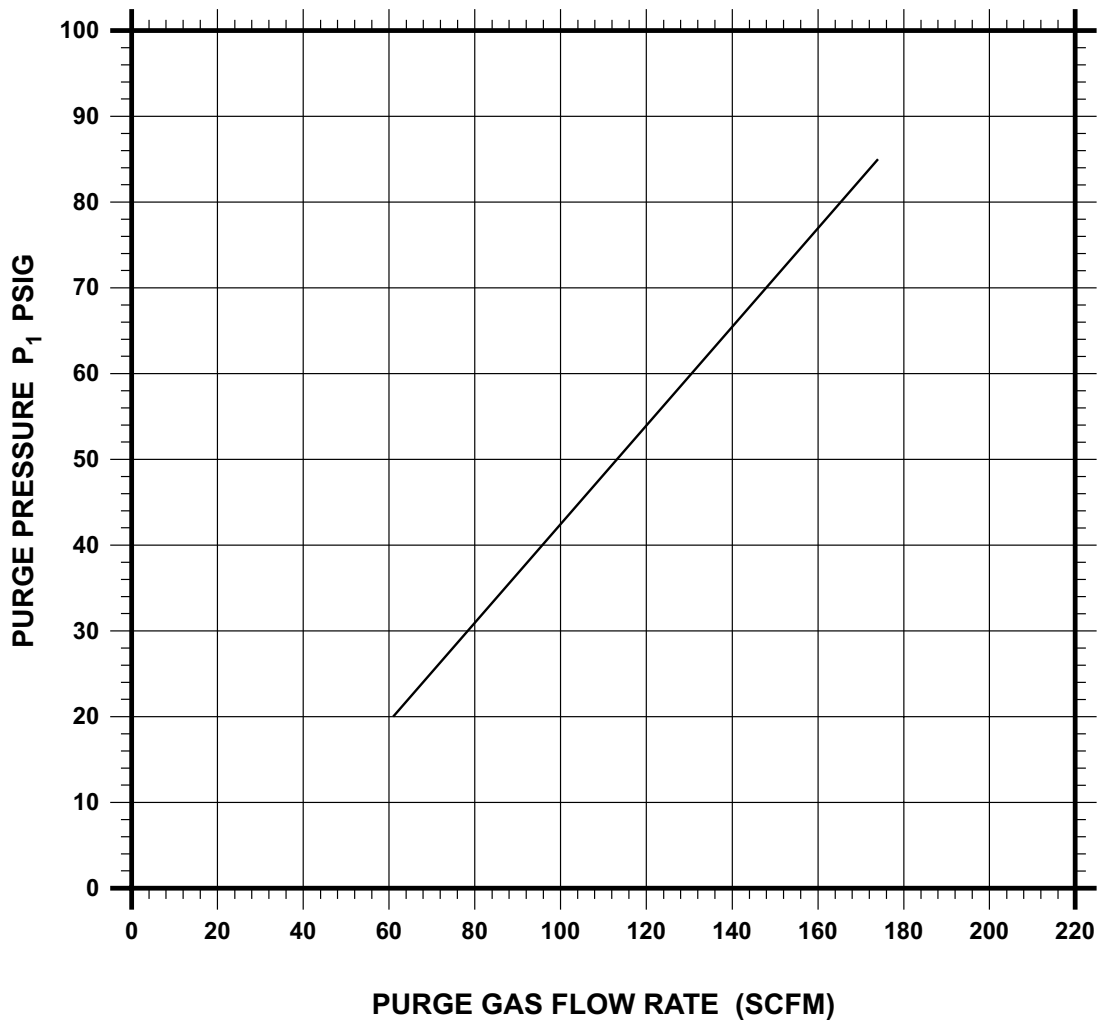
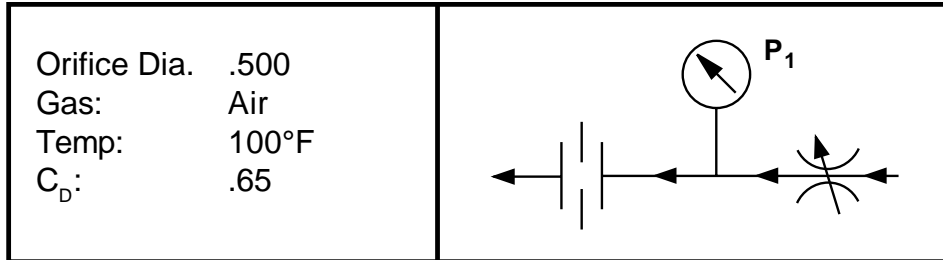

Figure C.11 — Critical Orifice Calibration Curve
(LSC1500)

HYDROBLOC LSC PURGE CURVES

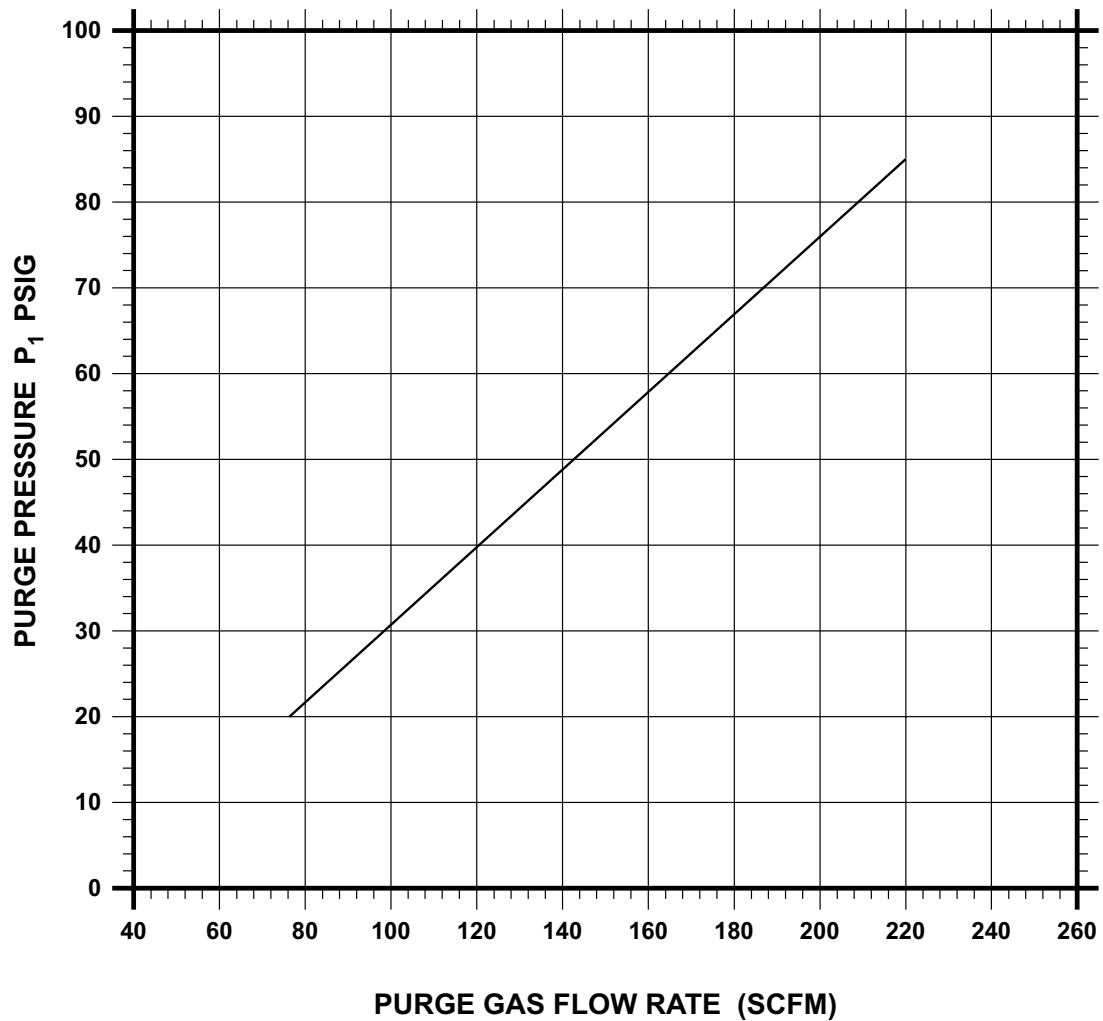
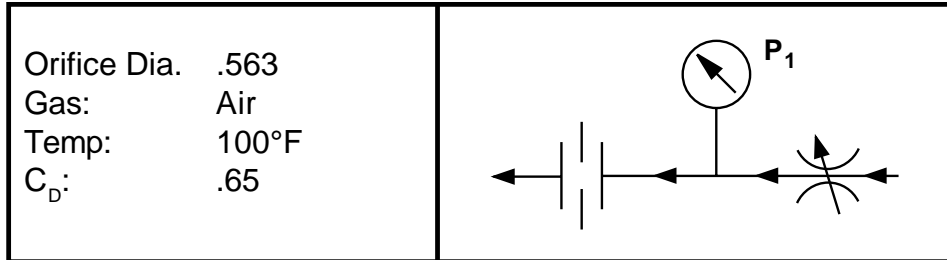

Figure C.12 — Critical Orifice Calibration Curve

(LSC2070)

HYDROBLOC LSC PURGE CURVES

<p>Orifice Dia. .688 Gas: Air Temp: 100°F C_D: .65</p>	
--	--

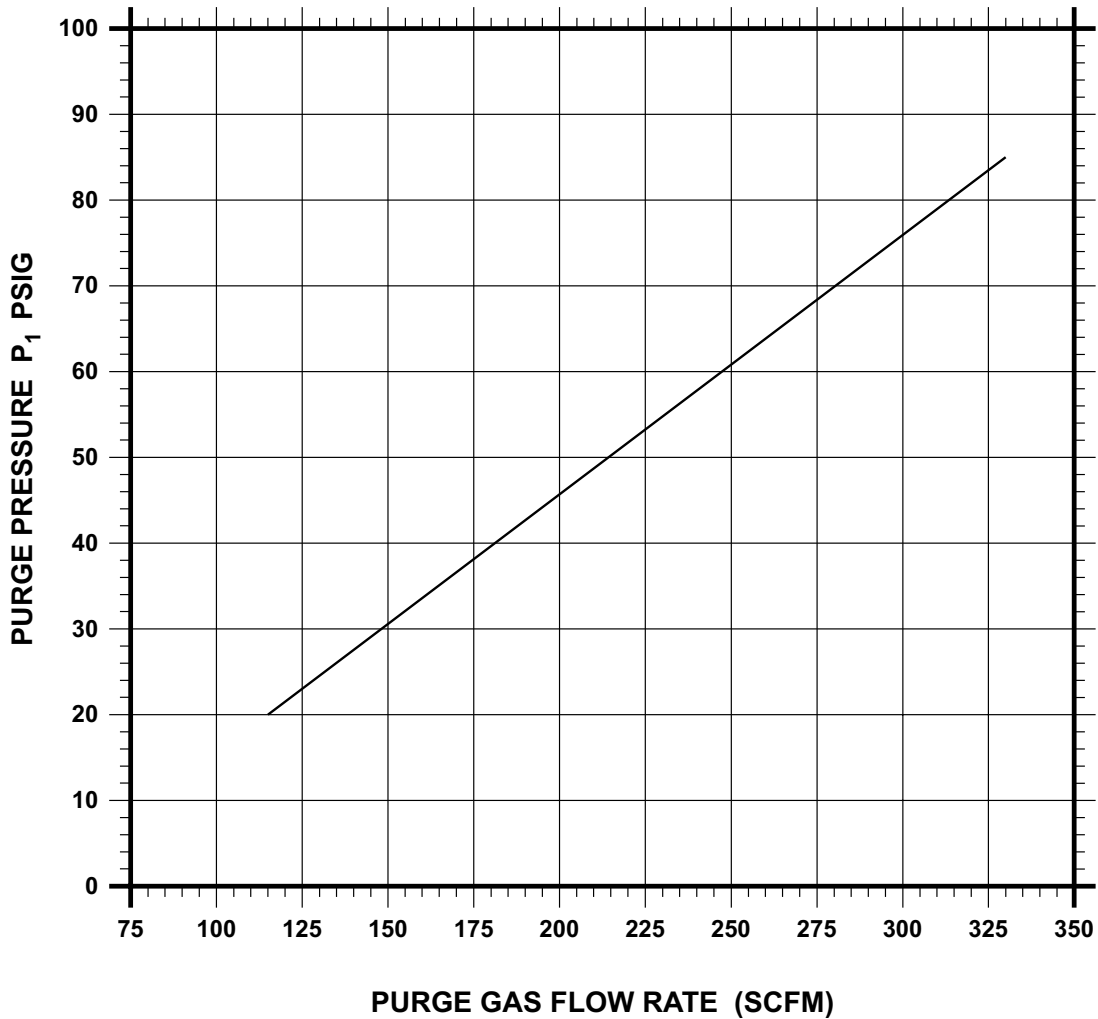

Figure C.13 — Critical Orifice Calibration Curve
(LSC2580)

HYDROBLOC LSC REPLACEMENT PARTS

Description	Quantity Required*	Model LSC60	Model LSC110	Model LSC130	Model LSC185	Model LSC240
Muffler	1	1283853	1283853	1283853	1283853	1283853
Relief Valve	1	1124704	1124704	1124704	1124704	1124704
Pressure Gauge	3	1125546	1125546	1125546	1125546	1125546
AQUADEX® Repair Kit	1	1207278	1207278	1207278	1207278	1207278
Inlet/Exhaust Valve Packing Kit	1	1283204	1283204	1283214	1283214	1283222
Purge Valve Packing Kit	1	1283207	1283207	1283207	1283207	1283233
Inlet/Exhaust Valve Repair Kit	1	1283203	1283203	1283213	1283213	1283221
Purge Valve Repair Kit	1	1283206	1283206	1283206	1283206	1283232
Purge Orifice	2	1198603	1218634	1180925	1180926	1198157
Solid State Controller	1	1286552	1286552	1286552	1286552	1286552
Solenoid Valve	2	1275475	1275475	1275475	1275475	1275475
Solenoid Coil	2	1284506	1284506	1284506	1284506	1284506
Control Board (CPU)	1	1274947	1274947	1274947	1274947	1274947
Programmed IC	1	1270702	1270702	1270702	1270702	1270702
Fuse (1/2AMP)	1	1222239	1222239	1222239	1222239	1222239
Power Supply	1	1261094	1261094	1261094	1261094	1261094
Solenoid Valve Spare	1	1276724	1276724	1276724	1276724	1276724
Display Panel Cable Assembly	1	1273367	1273367	1273367	1273367	1273367
Pressure Switch (Option 'A' & 'B')	1	1221910	1221910	1221910	1221910	1221910
Pressure Switch Cable Assy (Option 'A' and 'B')	1	1262602	1262602	1262602	1262602	1262602
Pilot Filter Replacement Element	1	1223259	1223259	1223259	1223259	1223259
Prefilter Replacement Element	1	1276832	1276841	1276841	1276851	1276851
Afterfilter Replacement Element	1	1276834	1276843	1276843	1276843	1276847
Automatic Drain Valve	1	1276741	1276741	1276741	1276741	1276741
Desiccant						
1269703, OPD-4-17-S, 17# container, (qty./dryer)				1		
1269704, OPD-4-34-S, 34# container, (qty./dryer)		2	3	3	5	6
1269705, OPD-4-150#, 150# container, (qty./dryer)						

* Quantity required indicates spares recommended for stocking and maintenance.

HYDROBLOC LSC REPLACEMENT PARTS

Description	Quantity Required*	Model LSC270	Model LSC360	Model LSC505	Model LSC630	Model LSC760
Muffler	1	1283853	1283853	1283285	1283285	1283285
Relief Valve	1	1124704	1124704	1124704	1124704	1124704
Pressure Gauge	3	1125546	1125546	1125546	1125546	1125546
AQUADEX® Repair Kit	1	1207278	1207278	1207278	1207278	1207278
Inlet/Exhaust Valve Packing Kit	1	1283225	1283225	1283227	1283229	1283231
Purge Valve Packing Kit	1	1283233	1283233	1283235	1283235	1283235
Inlet/Exhaust Valve Repair Kit	1	1283224	1283224	1283226	1283228	1283230
Purge Valve Repair Kit	1	1283232	1283232	1283234	1283234	1283234
Purge Orifice	2	1198157	1218635	1200806	1180918	1218638
Solid State Controller	1	1286552	1286552	1286552	1286552	1286552
Solenoid Valve	2	1275475	1275475	1275475	1275475	1275475
Solenoid Coil	2	1284506	1284506	1284506	1284506	1284506
Control Board (CPU)	1	1274947	1274947	1274947	1274947	1274947
Programmed IC	1	1270702	1270702	1270702	1270702	1270702
Fuse (1/2AMP)	1	1222239	1222239	1222239	1222239	1222239
Power Supply	1	1261094	1261094	1261094	1261094	1261094
Solenoid Valve Spare	1	1276724	1276724	1276724	1276724	1276724
Display Panel Cable Assembly	1	1273367	1273367	1273367	1273367	1273367
Pressure Switch (Option 'A' & 'B')	1	1221910	1221910	1221910	1221910	1221910
Pressure Switch Cable Assy (Option 'A' and 'B')	1	1262602	1262602	1262602	1262602	1262602
Pilot Filter Replacement Element	1	1223259	1223259	1223259	1223259	1223259
Prefilter Replacement Element	1	1276851	1276857	1276865	1276865	1276875
Afterfilter Replacement Element	1	1276847	1276861	1276861	1276869	1276871
Automatic Drain Valve	1	1276741	1276741	1276741	1276741	1276741
Desiccant						
1269703, OPD-4-17-S, 17# container, (qty./dryer)			1	1		
1269704, OPD-4-34-S, 34# container, (qty./dryer)		3		4	3	2
1269705, OPD-4-150#, 150# container, (qty./dryer)		1	2	2	3	4

* Quantity required indicates spares recommended for stocking and maintenance.

HYDROBLOC LSC REPLACEMENT PARTS

Description	Quantity Required*	Model LS1000	Model LS1250	Model LS1500	Model LS2070	Model LS2580
Muffler	1	1283853	1283853	1283853	1283853	1283853
Relief Valve	1	1124704	1124704	1124704	1124704	1124704
Pressure Gauge	3	1125546	1125546	1125546	1125546	1125546
AQUADEX® Repair Kit	1	1207278	1207278	1207278	1207278	1207278
Inlet/Exhaust Valve Packing Kit	1	1272497				
Inlet Valve Packing Kit	2		1256169	1256169	1252986	1252985
Exhaust Valve Packing Kit	2		1256167	1256168	1252986	1252986
Outlet & Purge Check Valve Packing Kit	1	1256401	1256401	1256401		
Inlet/Exhaust Valve Repair Kit	1	1272489				
Inlet Valve Repair Kit	1		1256174	1256174		
Exhaust Valve Repair Kit	1		1256172	1256173		
Outlet Valve Repair Kit	1	1256413	1256413	1256413		
Purge Valve Repair Kit	1	1256415	1256415	1256415		
Flow Restrictor Repair Kit	1			1205911	1205911	1205911
Flow Restrictor Rebuild Kit	1			1205937	1205937	1205937
Purge Orifice	2	1183533	1210703	1210703		
Purge Orifice	1				1268843	1268843
Solid State Controller	1	1286552				
Solenoid Valve	2	1275475				
Solenoid Coil	2	1284506				
Control Board (CPU)	1	1274947	1274947	1274947	1274947	1274947
Programmed IC	1	1270702	1270702	1270702	1270702	1270702
Fuse (1/2AMP)	1	1222239	1222239	1222239	1222239	1222239
Power Supply	1	1261094	1261094	1261094	1261094	1261094
Solenoid Valve Spare	1	1276724	1276724	1276724	1276724	1276724
Display Panel Cable Assembly	1	1273367	1273367	1273367	1273367	1273367
Pressure Switch (Option 'A' & 'B')	1	1221910	1221910	1221910	1221910	1221910
Pressure Switch Cable Assy (Option 'A' and 'B')	1	1262602	1262602	1262602	1262602	1262602
Pilot Filter Replacement Element	1	1223259	1223259	1223259	1223259	1223259
Prefilter Replacement Element (qty./filter)		1276881 (1)	1276889 (1)	1276881 (2)	1276889 (2)	1276889 (3)
Afterfilter Replacement Element (qty./filter)		1276885 (1)	1276885 (1)	1276885 (2)	1276893 (2)	1276893 (3)
Automatic Drain Valve	1	1276741	1276741	1276741	1276741	1276741
Desiccant						
1269703, OPD-4-17-S, 17# container, (qty./dryer)						
1269704, OPD-4-34-S, 34# container, (qty./dryer)			1			
1269705, OPD-4-150#, 150# container, (qty./dryer)		1		2		
1269706, OPD-4-350#, 350# container, (qty./dryer)		2	3	3	5	2
1269707, OPD-4-2000#, 2000# container, (qty./dryer)						1
1269708, OPD-25-150#, 150# container, (qty./dryer)					1	2

* Quantity required indicates spares recommended for stocking and maintenance.



DELTECH

A United Dominion Company

Flair Engineered Products

4647 SW 40th Avenue • Ocala, FL 34474-5799

Telephone 352-873-5700 • Fax 352-873-5744

WEB ADDRESS: www.udi-flair.com/deltech

E-MAIL: deltech@udi-flair.com

U.S. FACILITIES

New Castle, Delaware

Ocala, Florida

Stanley, North Carolina

CANADIAN FACILITIES

Brockville, Ontario

Tel. 800-893-5247 • Fax 800-318-0952

EUROPEAN FACILITIES

Horndean, Hants, England

Dortmund, Germany

Killarney, Ireland

Etten-Leur, The Netherlands

ASIAN FACILITIES

Jaipur, India

Vadodara, India

Tokyo, Japan

Pusan, Korea

Free Manuals Download Website

<http://myh66.com>

<http://usermanuals.us>

<http://www.somanuals.com>

<http://www.4manuals.cc>

<http://www.manual-lib.com>

<http://www.404manual.com>

<http://www.luxmanual.com>

<http://aubethermostatmanual.com>

Golf course search by state

<http://golfingnear.com>

Email search by domain

<http://emailbydomain.com>

Auto manuals search

<http://auto.somanuals.com>

TV manuals search

<http://tv.somanuals.com>