



# Dell 1815dn **Service Manual**

27 Mar 2006

**Information in this document is subject to change without notice.  
2010 Dell Inc. All rights reserved.**

Reproduction in any manner whatsoever without the written permission of Dell Inc. is strictly forbidden.  
Trademarks used in this text: Dell and the DELL logo are trademarks of Dell Inc.

Other trademarks and trade names may be used in this document to refer to the entities claiming the marks and names of their products. Dell Inc. disclaims any proprietary interest in trademarks and trade names other than its own.

# 1. Precautions

In order to prevent accidents and to prevent damage to the equipment please read the precautions listed below carefully before servicing the printer and follow them closely .

## 1.1 Safety Warning

(1) Only to be serviced by appropriately qualified service engineers.

High voltages and lasers inside this product are dangerous. This printer should only be serviced by a suitably trained and qualified service engineer.

(2) Use only Dell replacement parts

There are no user serviceable parts inside the printer . Do not make any unauthorized changes or additions to the printer, these could cause the printer to malfunction and create electric shock or fire hazards.

(3) Laser Safety Statement

The Printer is certified in the U.S. to conform to the requirements of DHHS 21 CFR, chapter 1 Subchapter J for Class 1(1) laser products, and elsewhere, it is certified as a Class I laser product conforming to the requirements of IEC 825. Class I laser products are not considered to be hazardous. The laser system and printer are designed so there is never any human access to laser radiation above a Class I level during normal operation, user maintenance, or prescribed service condition.

*Warning >> Never operate or service the printer with the protective cover removed from Laser/Scanner assembly. The reflected beam, although invisible, can damage your eyes. When using this product, these basic safety pre-cautions should always be followed to reduce risk of fire, electric shock, and injury to persons.*



CAUTION - INVISIBLE LASER RADIATION  
WHEN THIS COVER OPEN.  
DO NOT OPEN THIS COVER.

VORSICHT - UNSICHTBARE LASERSTRAHLUNG,  
WENN ABDECKUNG GEFFNET.  
NICHT DEM STRAHL AUSSETZEN.

ATTENTION - RAYONNEMENT LASER INVISIBLE EN CAS  
D'OUVERTURE. EXPOSITION DANGEREUSE  
AU FAISCEAU.

ATTENZIONE - RADIAZIONE LASER INVISIBLE IN CASO DI  
APERTURA. EVITARE L'ESPOSIZIONE AL  
FASCIO.

PRECAUCION - RADIACION LASER IVISIBLE CUANDO SE ABRE.  
EVITAR EXPONERSE AL RAYO.

ADVARSEL - USYNLIG LASERSTRÅLNING VED ÅBNING, N R  
SIKKERHEDSBRYDERE ER UDE AF FUNKTION.  
UNDG. UDSÆTTELSE FOR STRÅLNING.

ADVARSEL - USYNLIG LASERSTRÅLNING N R DEKSEL  
PÅNES. STIRR IKKE INN I STRÅLEN.  
UNNG. EKSPONERING FOR STRÅLEN.

WARNING - OSYNLIG LASERSTRÅLNING N R DENNA DEL  
R PPNAD OCH SPÄRREN R URKOPPLAD.  
BETRAKTA EJ STRÅLEN. STRÅLEN R FARLIG.

VARO! - AVATTAESSA JA SUOJALUKITUS OHITETTAESSA  
OLET ALTTIINA N KYM TT M LLE LASER-  
S TEILYLLE L KATSO S TEESEEN.

注 意 - 严禁揭开此盖, 以免激光泄露灼伤

주 의 - 이 덮개를 열면 레이저광에 노출될 수 있으므로  
주의하십시오.

## 1.2 Caution for safety

---

### 1.2.1 Toxic material

---

This product contains toxic materials that could cause illness if ingested.

- (1) If the LCD control panel is damaged it is possible for the liquid inside to leak. This liquid is toxic. Contact with the skin should be avoided, wash any splashes from eyes or skin immediately and contact your doctor. If the liquid gets into the mouth or is swallowed see a doctor immediately.
- (2) Please keep toner cartridges away from children. The toner powder contained in the toner cartridge may be harmful and if swallowed you should contact a doctor.

### 1.2.2 Electric Shock and Fire Safety Precautions

---

Failure to follow the following instructions could cause electric shock or potentially cause a fire.

- (1) Use only the correct voltage, failure to do so could damage the printer and potentially cause a fire or electric shock.
- (2) Use only the power cable supplied with the printer. Use of an incorrectly specified cable could cause the cable to overheat and potentially cause a fire.
- (3) Do not overload the power socket, this could lead to overheating of the cables inside the wall and could lead to a fire.
- (4) Do not allow water or other liquids to spill into the printer, this can cause electric shock. Do not allow paper clips, pins or other foreign objects to fall into the printer these could cause a short circuit leading to an electric shock or fire hazard.
- (5) Never touch the plugs on either end of the power cable with wet hands, this can cause electric shock. When servicing the printer remove the power plug from the wall socket.
- (6) Use caution when inserting or removing the power connector. The power connector must be inserted completely otherwise a poor contact could cause overheating possibly leading to a fire. When removing the power connector grip it firmly and pull.
- (7) Take care of the power cable. Do not allow it to become twisted, bent sharply round corners or otherwise damaged. Do not place objects on top of the power cable. If the power cable is damaged it could overheat and cause a fire or exposed cables could cause an electric shock. Replace a damaged power cable immediately, do not reuse or repair the damaged cable. Some chemicals can attack the coating on the power cable, weakening the cover or exposing cables causing fire and shock risks.
- (8) Ensure that the power sockets and plugs are not cracked or broken in any way. Any such defects should be repaired immediately. Take care not to cut or damage the power cable or plugs when moving the machine.
- (9) Use caution during thunder or lightning storms. Dell recommends that this machine be disconnected from the power source when such weather conditions are expected. Do not touch the machine or the power cord if it is still connected to the wall socket in these weather conditions.
- (10) Avoid damp or dusty areas, install the printer in a clean well ventilated location. Do not position the machine near a humidifier. Damp and dust build up inside the machine can lead to overheating and cause a fire.
- (11) Do not position the printer in direct sunlight. This will cause the temperature inside the printer to rise possibly leading to the printer failing to work properly and in extreme conditions could lead to a fire.
- (12) Do not insert any metal objects into the machine through the ventilator fan or other part of the casing, it could make contact with a high voltage conductor inside the machine and cause an electric shock.

## 1.2.3 Handling Precautions

---

The following instructions are for your own personal safety , to avoid injury and so as not to damage the printer

- (1) Ensure the printer is installed on a level surface, capable of supporting its weight. Failure to do so could cause the printer to tip or fall.
- (2) The printer contains many rollers, gears and fans. Take great care to ensure that you do not catch your fingers, hair or clothing in any of these rotating devices.
- (3) Do not place any small metal objects, containers of water , chemicals or other liquids close to the printer which if spilled could get into the machine and cause damage or a shock or fire hazard.
- (4) Do not install the machine in areas with high dust or moisture levels, beside on open window or close to a humidifier or heater. Damage could be caused to the printer in such areas.
- (5) Do not place candles, burning cigarettes, etc on the printer , These could cause a fire.

## 1.2.4 Assembly / Disassembly Precautions

---

Replace parts carefully, always use Dell parts. Take care to note the exact location of parts and also cable routing before dismantling any part of the machine. Ensure all parts and cables are replaced correctly . Please carry out the following procedures before dismantling the printer or replacing any parts.

- (1) Check the contents of the machine memory and make a note of any user settings. These will be erased if the mainboard or network card is replaced.
- (2) Ensure that power is disconnected before servicing or replacing any electrical parts.
- (3) Disconnect printer interface cables and power cables.
- (4) Only use approved spare parts. Ensure that part number , product name, any voltage, current or temperature rating are correct.
- (5) When removing or re-fitting any parts do not use excessive force, especially when fitting screws into plastic.
- (6) Take care not to drop any small parts into the machine.
- (7) Handling of the OPC Drum
  - The OPC Drum can be irreparably damaged if it exposed to light.  
Take care not to expose the OPC Drum either to direct sunlight or to fluorescent or incandescent room lighting. Exposure for as little as 5 mins can damage the surface' s photoconductive properties and will result in print quality degradation. Take extra care when servicing the printer . Remove the OPC Drum and store it in a black bag or other lightproof container . Take care when working with the covers(especially the top cover) open as light is admitted to the OPC area and can damage the OPC Drum.
  - Take care not to scratch the green surface of OPC Drum Unit.  
If the green surface of the Drum Cartridge is scratched or touched the print quality will be compromised.

## 1.2.5 Disregarding this warning may cause bodily injury

---

**(1) Be careful with the high temperature part.**

The fuser unit works at a high temperature. Use caution when working on the printer . Wait for the fuser to cool down before disassembly.

**(2) Do not put finger or hair into the rotating parts.**

When operating a printer, do not put hand or hair into the rotating parts (Paper feeding entrance, motor , fan, etc.). If do, you can get harm.

**(3) When you move the printer.**

This printer weighs 17.5kg including toner cartridge and cassette. Use safe lifting and handling techniques. Use the lifting handles located on each side of the machine. Back injury could be caused if you do not lift carefully .

**(4) Ensure the printer is installed safely.**

The printer weighs 17.5Kg, ensure the printer is installed on a level surface, capable of supporting its weight. Failure to do so could cause the printer to tip or fall possibly causing personal injury or damaging the printer .

**(5) Do not install the printer on a sloping or unstable surface. After installation, double check that the printer is stable.**

## 1.3 ESD Precautions

---

Certain semiconductor devices can be easily damaged by static electricity. Such components are commonly called “Electrostatically Sensitive (ES) Devices”, or ESDs. Examples of typical ESDs are: integrated circuits, some field effect transistors, and semiconductor “chip” components.

The techniques outlined below should be followed to help reduce the incidence of component damage caused by static electricity.

*Caution >>Be sure no power is applied to the chassis or circuit, and observe all other safety precautions.*

1. Immediately before handling a semiconductor component or semiconductor-equipped assembly, drain off any electrostatic charge on your body by touching a known earth ground. Alternatively, employ a commercially available wrist strap device, which should be removed for your personal safety reasons prior to applying power to the unit under test.
2. After removing an electrical assembly equipped with ESDs, place the assembly on a conductive surface, such as aluminum or copper foil, or conductive foam, to prevent electrostatic charge buildup in the vicinity of the assembly.
3. Use only a grounded tip soldering iron to solder or desolder ESDs.
4. Use only an “anti-static” solder removal device. Some solder removal devices not classified as “anti-static” can generate electrical charges sufficient to damage ESDs.
5. Do not use Freon-propelled chemicals. When sprayed, these can generate electrical charges sufficient to damage ESDs.
6. Do not remove a replacement ESD from its protective packaging until immediately before installing it. Most replacement ESDs are packaged with all leads shorted together by conductive foam, aluminum foil, or a comparable conductive material.
7. Immediately before removing the protective shorting material from the leads of a replacement ESD, touch the protective material to the chassis or circuit assembly into which the device will be installed.
8. Maintain continuous electrical contact between the ESD and the assembly into which it will be installed, until completely plugged or soldered into the circuit.
9. Minimize bodily motions when handling unpackaged replacement ESDs. Normal motions, such as the brushing together of clothing fabric and lifting one’s foot from a carpeted floor, can generate static electricity sufficient to damage an ESD.

## 1.4 Super Capacitor or Lithium Battery Precautions

---

1. Exercise caution when replacing a super capacitor or Lithium battery. There could be a danger of explosion and subsequent operator injury and/or equipment damage if incorrectly installed.
2. Be sure to replace the battery with the same or equivalent type recommended by the manufacturer.
3. Super capacitor or Lithium batteries contain toxic substances and should not be opened, crushed, or burned for disposal.
4. Dispose of used batteries according to the manufacturer’s instructions.

## 2. Reference Information

This chapter contains the tools list, list of abbreviations used in this manual, and a guide to the location space required when installing the printer. A definition of tests pages and Wireless Network information definition is also included.

### 2.1 Tool for Troubleshooting

The following tools are recommended safe and easy troubleshooting as described in this service manual.

- **DVM(Digital Volt Meter)**

Standard : Indicates more than 3 digits.

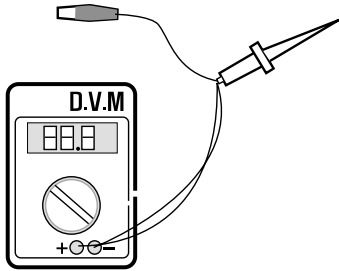

- **Driver**

Standard : "-" type, "+" type (M3 long, M3 short, M2 long, M2 short).

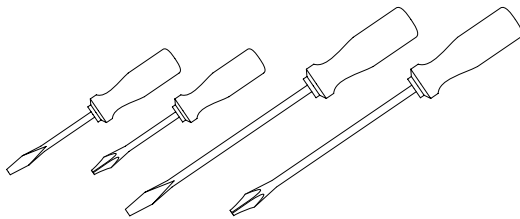

- **Tweezers**

Standard : For general home use, small type.



- **Cotton Swab**

Standard : For general home use, for medical service.



- **Cleaning Equipments**

Standard : An IPA(Isopropyl Alcohol)dry wipe tissue or a gentle neutral detergent and lint-free cloth.

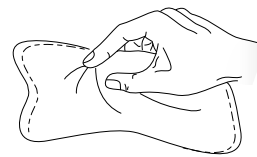

- **Vacuum Cleaner**

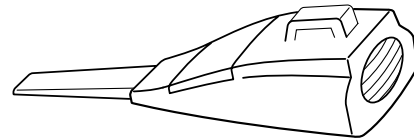

- **Spring Hook**

Standard : For general use



- **Software (Driver) installation CD ROM**

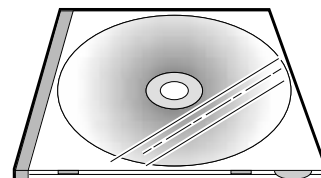



## 2.2 Acronyms and Abbreviations

The table in the below explains abbreviations used in this service manual.

The contents of this service manual are declared with abbreviations in many parts. Please refer to the table.

AC	Alternating Current	IC	integrated circuit
ADF	Automatic Document Feeder	IDE	Intelligent Drive electronics or Imbedded Drive Electronics
ASIC	Application Specific Integrated Circuit	IEEE	Institute of Electrical and Electronics Engineers. Inc
ASSY	assembly	IPA	Isopropyl Alcohol
BIOS	Basic Input Output System	IPM	Images Per Minutes
CCD	Charge Coupled Device	LAN	local area network
CIS	Contact Image Sensor	lb	pound(s)
CMOS	Complementary Metal Oxide Semiconductor	LBP	Laser Beam Printer
CN	connector	LCD	Liquid Crystal Display
CON	connector	LED	Light Emitting Diode
CPU	Central Processing Unit	LSU	Laser Scanning Unit
dB	decibel	MB	Megabyte
dbA	decibelampere	MHz	Megahertz
dBm	decibel milliwatt	NVRAM	Nonvolatile random access memory
DC	direct current	OPC	Organic Photo Conductor
DCU	Diagnostic Control Unit	PBA	Printed Board Assembly
DPI	Dot Per Inch	PCL	Printer Command Language , Printer Control Language
DRAM	Dynamic Random Access Memory	PDL	Page Discription Language
DVM	Digital Voltmeter	PPM	Page Per Minute
ECP	Enhanced Capability Port	PTL	Pre-Transfer Lamp
EEPROM	Electronically Erasable Programmable Read Only Memory	Q'ty	Quantity
EMI	Electro Magnetic Interference	RAM	Random Access Memory
EP	electrophotographic	ROM	Read Only Memory
EPP	Enhanced Parallel Port	SCF	Second Cassette Feeder
FW	firmware	SMPS	Switching Mode Power Supply
GDI	graphics device interface	SPGP	SEC Printer Graphic Processor
GND	ground	SPL	SEC Printer Language
HBP	Host Based Printing	Spool	Simultaneous Peripheral Operation Online
HDD	Hard Disk Drive	SW	Switch
HV	high voltage	Sync	Synchronous or synchronization
HVPS	High Voltage Power Supply	USB	Universal Serial Bus
I/F	interface		
I/O	Input and Output		

## 2.3 The Sample Pattern for the Test

The sample pattern shown in below is the standard pattern used in the factory .  
 The life of the toner cartridge and the printing speed are measured using the pattern shown below .  
 (The image is 70% of the actual A4 size).

### 2.3.1 A4 ISO 19752 Standard Pattern

This test page is reproduced at 70% of the normal A4 size

ABCDEFGHIJKLMN...  
 ABCDEFGHIJKLMN...  
 HIJKLMN...  
 HIJKLMN...

---

Stephen J. Singel  
 Labanda Sinpat Abarress  
 Tendar, BSF  
 URANGLE

27 March 2003

---

Jonathan Q. Maderia

Inpert Mampem Abareess  
 2343 Stantin Dawer Lank  
 Benhibe, SDF

Mr. Maderia:

Nam liber tempor cum soluta nobis eleifend option cogue nihil consequat, velillum. Dolore eu zril feugiat nulla facilisis at vero eros accumsan et iust— odio dignissim qui blandit praesent lutatum ril lobortis nisl ut aliquip ex ea commodo consequat. Duis autem vel eum iriure dolor in hendrerit vulputate velit esse molestie tincidunt ut laoreet dolore magna aliquam erat volutpat. Ut wisi enim ad minim veniam, quis nostrud exerci tation ullamcorper suscipit lotis nisl ut aliquip ex ea commodo con-sequat. Lorem ipsum dolor sit.

Amet, consectetur adipiscing elit, s'd diam nonummy nibh veniam, recneps adipiscing elit, sed diam nonummy nibh laoreet dolore magna aliam erat volutpat. Ut wisi enim minim veniam, quisient nostrud. Soluta nobis eleifend optn cogue nihil imerdiet domg id quod mzim plerat facer posim aum. Lorem ipsum dolor sit amet, consectuer. Duis autem vel eum iriure dolor in hendrerit vulputate velit esse ea commodo molestie.

Nam liber tempor cum soluta nobis eleifend option cogue nihil consequat, velillum. Dolore eu zril feugiat nulla facilisis at vero eros accumsan et iust— odio dignissim qui blandit praesent lutatum ril lobortis nisl ut enod.

Singabet,

Stephen J. Singel  
 Demperta Aminerimum  
 Labanda Sinpat Abarress

SJS: dwg

**Stnecrep Balreeneeps**

Category	Value
A	100
B	75
C	50
D	25
E	10

ABCDEFGHIJKLMN...  
 ABCDEFGHIJKLMN...  
 HIJKLMN...  
 HIJKLMN...

## 3. Product Specifications

---

Specifications are correct at the time of printing. Product specifications are subject to change without notice. See below for product specifications.

### 3.1 Product Overview

---

- Concept: MFP of high speed
- Target User : Small & Medium Business
- Customer Benefits (Sales Points)
  - Fast Printing Speed  
(25ppm in A4 / 27ppm in Letter)
  - Multifunction Network Solution  
(Scan-to-Email, Scan-to-SMB, Scan-to-FTP)
  - Duplex Capability
  - Direct USB Connectivity 2nd Version  
(PDF Direct Printing)
  - Small Foot Print
- Key Features
  - 25 ppm Print speed/14 cpm Copy Speed
  - 1200 dpi Print Resolution (Addressable)
  - PCL6, PS3(SCX-5530FN)
  - 64MB System Memory/32MB DIMM(5530FN)
  - 50 ADF
  - 250 sh Paper Input / 150 sh Paper Output
  - 33.6 Kbps Fax Modem (5530FN only)
  - Duplex Print (5530FN only)

### 3.2 Product General Specifications

Items			Remarks
General	Major Features	Fax, Copier, Print, Scan, ADF, Scan to USB Key	
	Size (W*D*H) w/o Hand Set	450mmx423mmx456mm (17.7x16.7x18")	
	Net Weight(Inc. Toner Cartridge)	17.5kg	
	Net Weight(exc. Toner Cartridge)	16.5kg	
	Gross Weight(with package)	22.5kg	
	LCD	16*2 Char	w/o back light
	I/O Interface	USB2.0 (High Speed)	
	MPU	Chorus-m / 300MHz	System Bus 100MHz
Power Consumption	Printing Operation	450 W	EPA
	Sleep Mode	30 W	EPA
	Power Switch	Yes	
Power Supply	Input Voltage	Low Voltage : 110 ~ 127VAC	
		High Voltage : 220 ~ 240VAC	
	Input Frequency	50 / 60Hz(+/- 3Hz)	
Noise	Printing 54dBA		
	Copy	55dBA	
	Standby	39dBA(TBD)	
Warm Up Time	from Cold Status	Less than 42 seconds	
Machine Life	Max. Monthly Volume (Duty Cycle)	Print	25000pages
		Scan 1000pages	
		ADF	1000pages
	Average Monthly Print Volume	1500pages	
	Machine Life	200,000pages	
Periodic Replacing Parts	Pickup Roller	150,000 Pages	
	Pad Unit (Tray)	150,000 Pages	
	Pad Unit (ADF)	20,000 Pages	
	Transfer Roller	70,000 Pages	
	Fuser Unit	80,000 Pages	
	Paper Tray	150,000 Pages	
Environmental	Temperature	Operating	10~32 °C
		Non Operating	-20~40 °C
	Humidity	Operating	20~80%
		Non Operating	10~90%
	Altitude	Max 8,200ft	

Items		8 Y @gYf A: D%, % Xb	Remarks	
EMI Approval		Class B		
Device Memory	Standard / Max.	64MB / 192MB(Std./Max)	Duplex (Standard / Max)	
		Program , Font (8M) + Data (2M) + Fax (4M) + Scan (6M) + Codec (4M) + N/W (8M) + Print (16M) + Scan To Email (16M) = 64MB	: 64MB + 32MB / 192MB	
	Type	SDRAM		
	Expand Memory Slot , Type	SDRAM DIMM	Expand Memory specification would be defined separate note. 128MB Micron Memory will work only in GEU Burst mode off.	
	Compression Technology	YES		
PRINT	Print Speed	Simplex	27ppm/Ltr, 25ppm/A4 (600 dpi)	
		Duplex	18ipm/Ltr, 17ipm/Ltr(600dpi)	Usable paper sizes (Let. A4. Folio.Legal), Oficio
	Print Emulation		GDI, PCL6, PCL5e PostScript Level3(Clone)	
	Auto Emulation Sensing		YES	
	Font	Type	45 Scalable, 1 Bitmap	Refer to the attached file.
		Number	N/A	
	Power Save		Yes (5/10/15/30/45min.)	
	Resolution	Normal	600x600dpi (1200x1200,)	
		RET	Yes	
	Toner Save		Yes (No dedicated button on CP)	
	Memory		16MB	
	FPOT	From Stand by	Approx. 10 seconds (From LSU 'ON', A4)	
		From Cold Status	Less than 50 seconds	
	Duplex Print		1815dn : Yes	Manual Duplex through MP tray would be possible on 1815n model.
	Printable Area		208 x 273 mm (Letter)	
Halftone(Gray Scale)		256levels		
SCAN	Scan Method		Color CCD	
	Scan Speed through ADF	Linearity	Approx. 15sec (USB 2.0)	USB 2.0, 300dpi, Letter Size, Pentium 4 2.XGHz, 128MB RAM
		Gray	Approx. 20sec (USB 2.0)	
		Color	Approx. 30sec (USB 2.0)	
	Scan Speed through Platen	Linearity	Approx. 15sec (USB 2.0)	
		Gray	Approx. 20sec (USB 2.0)	
Color 75dpi/300dpi		Approx. 30sec (USB 2.0)		

Items		Dell Laser MFP 1815dn		Remarks	
	Resolution	Optical	600*1200dpi	75, 300, 600dpi horizontal	
		Enhanced	4800dpi*4800dpi		
	Halftone		256level	for only optical resolution	
	Scan Size	Max. Document Width	Max.216mm(8.5")		
		Effective Scan Width	Max 208mm(8.2inch)		
	Scan-to		Scan to Application/Network/Email/USB Key		
	Scan To Email Locations		399 locations in the Directory with Search, Edit and Store facilities		
	Scan Depth	Color	24 bit		
		Mono	1bit for Lineart, 8 Bit for Gray scale		
	COPY	Copy Quality Selection or Original Image type selection Mode	Text	600x300dpi	
Text/Photo			600x300dpi		
Photo			600x600dpi		
Other			N/A		
FCOT		Stand by	Approx. 10 seconds : Platen Approx. 15 seconds : ADF		
		From Cold Status	50 seconds		
Copy Speed / Letter		SDMC at all mode	27cpm/Ltr, 25cpm/A4		SDMC: Single Document Multiple Copy MDSC: Multi-document Single Copy
		MDSC at Text, Text/Photo (600x300dpi)	14cpm		
		MDSC at Photo Mode (600x600dpi)	8cpm		
Origin Alignment		Platen	REAR LEFT		
		ADF	Center		
Resolution		Scan:600x300dpi, 600*600dpi Print:600*600dpi			
Zoom Range		25% to 400% for Platen 25% to 100% for ADF			
Number of Copies		1~199			
Preset Y		es			
Contrast Levels		5 level			
Copy Mode(=Quality)		Text, Text/Photo, Photo			

Items		Dell Laser MFP 1815dn	Remarks	
COPY(Continued)	Collation Copy	Yes		
	Auto return to default mode	Yes	Time can be changeable; 15,30,60,180sec, Off	
	Changeable Default mode	Contrast, Image, Reduce/Enlarge, No. of Copies		
	Special Copy	N-up copy	2-up, 4-up (ADF only)	
		Collation Copy	Yes (ADF only)	
		Auto Fit Copy	Yes(Platen only)	
		ID Copy	Yes(Platen only)	* Copy 2-side printed original document into one page (ex. ID Card Copy)
Clone		Yes(Platen only)		
Poster	Yes(Platen only)			
TELEPHONE	Handset	No		
	On hook Dial *	Yes		
	Search *	Yes(Phone Book)	by using Phone Book Button(Same as Rocky)	
	1-Touch Dial *	10 Numeric Key pad (No dedicated keys)		
	Speed Dial *	400 locations(00~399) include 1-touch dials	Total locations can be stored	
	TAD I/F	Yes		
	Tone/Pulse	Selectable in Technical Mode		
	Pause Y	es		
	Auto Redial	Yes		
	Last Number Redial	Yes		
	Distinctive Ring	Yes		
	Caller ID	No		
	External Phone Interface	Yes		
	Report & List Print out	Tx/Rx Journal	Yes	
		Confirmation	Yes	
		Help List	No	
		Auto Dial List	Yes	
		System Data List	List all user setting	
	Sound Control	Ring Volume	Yes(Off, Low, MED, HIGH)	
		Key Volume	Yes(On, Off)	
Alarm Volume		Yes(On, Off)		
Speaker		Yes(On, Off, Comm. Error)		

Items		Dell Laser MFP 1815dn	Remarks	
Fax	Compatibility	ITU-T G3		
	Communication System		PSTN/PABX	
	Modem Speed	33.6Kbps		
	TX Speed	3sec	LRT/MMR/CCITT No.1 Chart/33.6Kbps Compression MH/MR/MMR/JPEG	
	Color Fax	Yes(Sending Only)		
	ECM	Yes		
	Resolution	Std	203*98dpi	
		Fine	203*196dpi	
		S.Fine	300*300dpi	
	Scan Speed(ADF)	Std	2.5 sec/ LTR	
		Fine/S.Fine	5 sec/ LTR	
	Changeable Default mode	Darkness, Original Type, Reduce/ Enlarge, No. Of Copies		
	Rx fax duplex print out	Yes only for 1815dn model.		
	Multiple page scan speed	14 ppm/LTR, Std mode	203x98dpi, ITU-T #1(TBD)	
	Receive Mode	Fax, TEL, Ans/Fax, DRPD		
	Memory	Capacity	4MB	
		Optional Memory	No	
		Max locations to store to 1 Group Dial	400 locations	
		Fax Forward	Yes(On/Off)	
		Broadcasting	up to 409 locations?	
		Cover page	Yes	
		Delayed fax	Yes	
		Fax Forward to Email Addresses	Yes (Enable / Disable), max 10 locations	
Memory RX	Yes			
Functions	Voice Request	No		
	TTI	Yes		
	RTI	Yes		
	Polling	No		
	Earth/Recall	No		
	Max modem Speed	Yes		
	Auto Reduction	Yes		
F/W Remote upgrade	Yes			
Junk Fax barrier	Yes			
Secure Receive	Yes			
Memory Back-up	Yes, Max. 43hours			



Items		Dell Laser MFP 1815dn		Remarks
Paper Handling	Capacity (20lbs)	Main Tray	250sheets	
		Bypass	50 Sheets	
	Optional Cassette		250sheets	
	Output Capacity		Face Down: 150Sheets/20lb Face Up: 1Sheet	
Paper Handling (Continued)	Output Control		Face Up/Down controlled manually by opening rear cover	
	Paper Size	Main Tray	A4,Letter,Legal,Folio,Executive, B5,A4,Oficio	
		Bypass	Envelope6 3/4,7 3/4,#9, #10,DL, C5,B5, 3"x5"	
	Paper Weight	Main Tray	16~24 lb.	
		Bypass	16~43 lb.	
	Paper Path	Standard output	Bottom to Middle Front (FIFO)	
		Straight Through	Face up, Single Sheet	
	Paper Size	Max	216 x 356mm(8.5"x14")	
		Min	76 x 127mm(3"x5")	
	ADF	Paper Weight	12.5~28lb	
		Capacity	50 sheets	
		Document Size Width	142mm - 216mm(5.6" - 8.5")	
		Document Size Length	148 mm - 356mm(5.8" - 14.0")	
	Jam Rate	Cassette, 2nd Feeder	1/2000	*In H/H and L/L condition, the spec. of JAM rate and Mis- pickup rate Double Feed is doubled.  Cassette : Jam:1/1000, Double Feed:1/500
		ADF	1/1000	
	Multi-Feed Rate	Cassette, 2nd Feeder	1/1000	
		ADF	1/500	
Printing Skew	Top	1.5/177.8mm (1st Tray) 2.0/177.8 (2nd Tray)	2.0/177.8 (Duplex)	
	Side	2/241.3mm (1st Tray) 2.5/241.3mm (2nd Tray)	2.5/177.8 (Duplex)	
Copy Skew	Top	2.5/190mm (1st Tray) 3.0/190mm (2nd Tray)		
	Side	3.5/277mm (1st Tray) 4.0/277mm (2nd Tray)		

Items		Dell Laser MFP 1815dn	Remarks	
Software	Compatibility	DOS	No	
		Win 3.x	No	
		Win 95	No	
		Win 98	Yes	
		Win ME	Yes	
		Win NT 4.0	Yes	
		Win 2000	Yes	
		Win 2003	Yes	Addition Win2003
		Win XP	Yes	
		Longhorn	No	
		64 bit	No	
		Mac	Yes, English only web version	
		Linux	Yes, English only	
	WHQL	MFP	Yes for 2000 & XP	
	Driver	Printer	GDI, PCL6, PostScript Level3(Std.)	
TWAIN		Yes		
WIA		Yes		
PSU		Yes		
PC-FAX		Yes	PC fax including to network fax	
Accessory	Quick setup guide		Yes	
	Quick Reference Guide		Yes	
	Owner's manual		Yes	
	S/W CD ROM		CDs for Print Driver, Scan Driver, RCP	
	S/W	OCR	PaperPort	
		FAX	N/A	
		SCAN S/W	PaperPort	
	Toner Cartridge		1 EA (3K yield ISO 19752 5% Coverage)	
	Power Cable		1 EA	
	Telephone Jack		1 EA	
Printer Cable		No		
Consumables	Type		One Piece Type Toner Cartridge	
	How to install		Front door open and front loading	
	Toner	Life	Initial 3Kpages (5% ISO 19752Test Pattern) running Standard: 3Kpages High yield: 5 K pages	
		Level Sensor	No	
	Toner Count		Yes (Dot Counter)	

## 4. System Outline

---

This document is the product specification for Dell 1815dn. Dell 1815dn is a Multi-Function Peripheral (MFP) integrating a plain fax, a B/W laser printer, a color flatbed scanner, and a B/W copier. Dell 1815dn is developed for small workgroup and personal office customers. The main product concept is °∞High Speed and High Quality.°± This model has 27ppm print-speed, 3 sec transmission-speed for fax, 33.6kbps fax-transfer rate, optical 600 dpi color scanner, and 1200 dpi printer.

Dell 1815dn is developed to meet standard approvals of FCC Part 15 Class B, FCC Part 68, IC 60950, and cUL for the US and Canada. Other markets covered are Europe, Latin America and Emerging Markets. Agency Certifications will be attained to enable launch in all target markets

### 4.1 System Configurations

---

Dell 1815dn is made up of the Main Control part, Operation Panel part, Scanner part, Line interface part and Power part. Each Part is a separate Module which focuses on common and standard design of different kind of products. Main control part adopting Fax & LBP Printer exclusive Controller is composed of 1 CPU and 1 Board. Scanner part is composed of ADF and Platen and is connected with Main by Harness. Line Interface part is designed to apply TBR21 standard (Domestic, Europe, etc.)

#### 4.1.1 CPU Part

---

1) CPU : ARM920T , which is exclusive controller to execute Printer & FAX Function and to execute operation block by flash memory within system program, and to control whole system.

- Main function block
- Completely Integrated System for Embedded Applications
- PVC
  - Dual / Single Beam, - LVDS Pad (VDO, HSYNC), - Support A3 1200dpi, multi-pass color.
- HPVC
  - Dual / Single Beam, - LVDS Pad (VDO, HSYNC), - Support A4 600dpi, multi-pass color.
- DMA
  - 6 Channels (if not use CIP4e, 4ch is available for external DMA.  
if CIP4E used (a4 DMA channel use), 2ch available for external DMA)
- Operation Frequency : CPU Core -> over 300MHz, System Bus -> 100MHz
- Operation Voltage : Core Voltage -> 1.2V, I/O Pad Voltage -> 3.3V, RTC Voltage -> 3V

2) Flash Memory : Record System Program, and download System Program by PC INTERFACE. FAX for Journal List, and Memory for One Touch Dial, Speed Dial List.

- size : 16M Byte (NOR Flash)
- Access Time: 90ns (Max)
- Page Access Time: 25ns (Max)

3) SDRAM : is used as Swath Buffer in Printing, Scan Buffer in Scanning, ECM Buffer in FAX receiving, and System Working Memory Area

- size : 64Mbyte(Basic) , 96Mbyte(Duplex)
  - 4MB : System Working Memory Area and Scan Buffer
  - 4MB : FAX Memory Receive Area
  - 16MB : Printing System Working Memory Area
- Max Frequency : 166MHz
- store Fax Receive Memory Data by using Battery

## 4.1.2 FAX Section

Modem Part

### BLOCK DIAGRAM

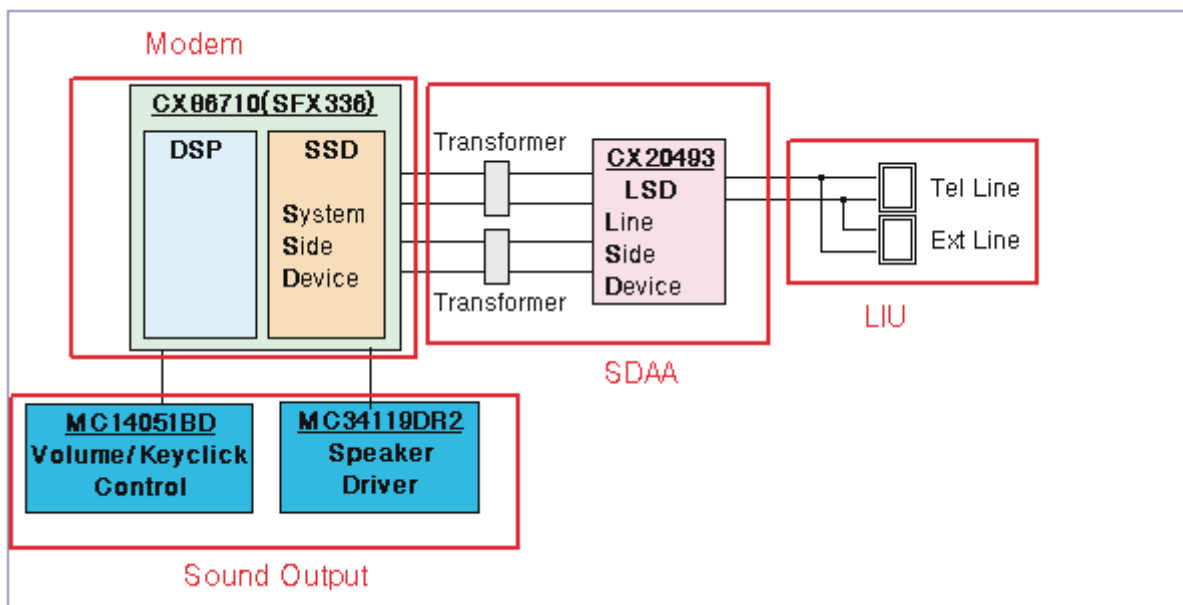

Implemented by based on Conexant DAA (Data Access Arrangement) Solution, and is roughly composed of two kinds Chip Solution

- CX86710 (SFX336): Existing Modem Chip which adds SSD (System Side Device) for interfacing between LSD and DIB of FM336Plus Core
- CX20493 (LSD) : LIU (Line Interface Unit) Chip which is controlled by SSD and satisfies each PSTN Requirements by modulating internal Configuration with connecting Tel Line.

**Modem (SFX336) specification.**

- 2-wire half-duplex fax modem modes with send and receive data rates up to 33,600 bps
- V.17, V.34, V.29, V.27 ter, and V.21 Channel 2
- Short train option in V.17 and V.27 ter
- PSTN session starting
- V.8 and V.8bis signaling
- HDLC support at all speeds
- Flag generation, 0-bit stuffing, ITU CRC-16 or CRC-32 calculation and generation
- Flag detection, 0-bit deletion, ITU CRC-16 or CRC-32 check sum error detection
- FSK flag pattern detection during high-speed receiving
- Tone modes and features
- Programmable single or dual tone generation
- DTMF receiver
- Tone detection with three programmable tone detectors
- Receive dynamic range:
  - 0 dBm to +43 dBm for V.17, V.29, V.27 ter and V.21 Channel 2
  - 9dBm to -43 dBm for V.34 half-duplex
- Digital speaker output to monitor received signal
- Two 16-byte FIFO data buffers for burst data transfer with extension up to 255 bytes
- V.21 Channel 1 Flag detect
- V.21 Channel 1 Flag detect
- +3.3V only operation
- Typical power consumption
- Normal mode: 264 mW

**Signal Transition of DAA Solution**

Line Interface Signal of Tel Line and LSD is Analog Signal.

- 2) there is A/D, D/A Converter in LSD, so Analog Signal from Tel Line is converted in Digital through A/D Converter in DAA and transfer to SSD by DIB Capacitor
- Digital Signal from SSD is converted to Analog by D/A Converter in DAA and transfer to Tel Line

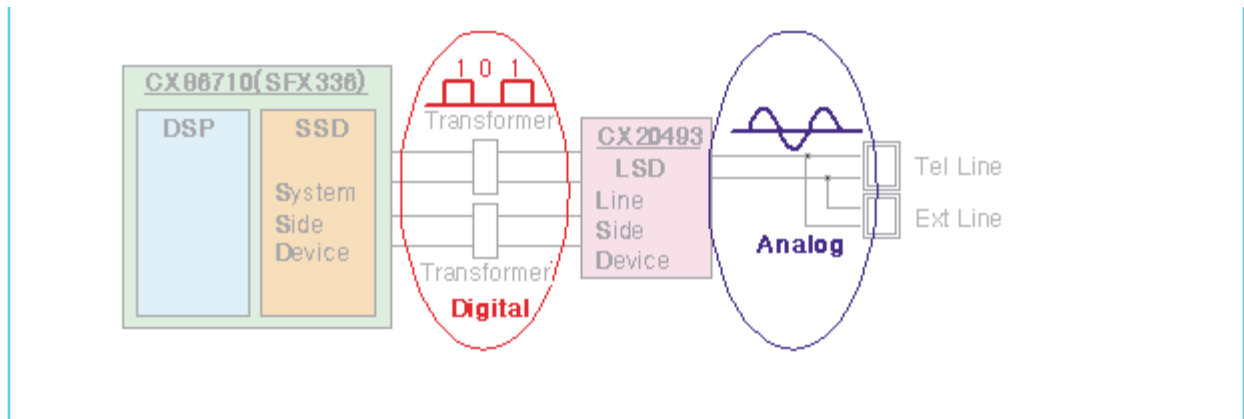

Transformer transfer Clock from SSD to LSD and Clock Frequency is 4.032MHz.

LSD full wave rectifies Clock to use as inner Power supply and also use as Main Clock for DIB Protocol Sync between LSD and SSD. Transformer transfer Clock by separating Primary and Secondary, and amplifies Clock Level to LSD by Coil Turns Ratio 1:1.16.

■ Clock

- Clock is supplied by transformer from SSD to LSD, and there is PWROUT to adjust output impedance of Clock

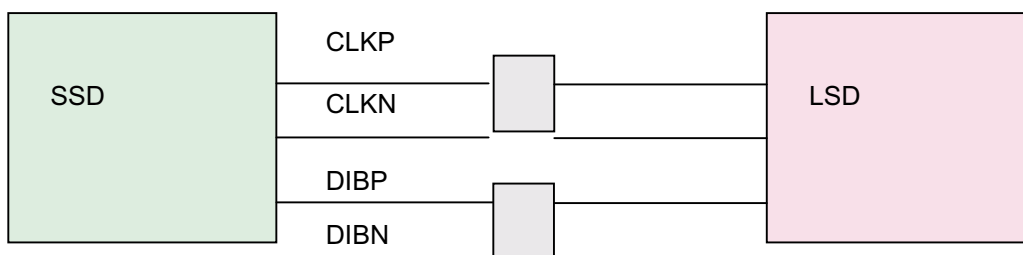

Out Driver is inside SSD and CLKSHIGH Resistor to adjust duty of HLPWR Resistor and Clock.

Clock from SSD to LSD has Differential structure of 180 phase difference for Noise Robustness

DIB Data transfer Data from SSD to LSD by Transformer, and also transfer specific data from LSD to SSD.

After transferring data from SSD, RSP is transferred and LSD recognizes RSP and change LSD to output Driver transfer Data to SSD.

DIB Data form SSD to LSD by Transformer has Differential structure of 180 phase difference between DIBP and DIBN for Noise Robustness

## 4.1.3 Line Interface Part

---

This is Connection Part between system and PSTN(Public Switched Telephone Network), and primary circuit is usually located. Main functions are Line Interface, Telephone Connection and Line Condition Monitoring.

### 1 Telephone Line Connection

- ① Modular Plug : RJ-11C
- ② LIU PBA Modular Type : 623 PCB4-4
- ③ Line Code Length : 2500 ± 50mm
- ④ Line Code Color : Black

### ON HOOK state Characteristic

#### 1) DC Resistance

- ① DP Dial Mode (Direct Current 30mA) : 50 ~ 300ohm
- ② DTMF Dial Mode (Direct Current 20mA) : 50 ~ 540ohm

#### 2) Ring Sensitivity

- ① Ring detection Voltage : 40Vrms ~ 150Vrms (condition : Current=25mA, Frequency=15Hz)  
product Margin : 30Vrms ~ 150Vrms
- ② Ring detection Frequency : 15.3Hz ~ 68Hz (condition : Voltage=45Vrms, Current=25mA )  
product Margin : 15Hz ~ 70Hz
- ③ Ring detection Current : 20mA ~ 100mA (condition : Voltage=40Vrms, Frequency=20Hz)  
product Margin : over 15mA

#### 3) False Ring Sound

- ① Ring Frequency : 750 Hz + 1020 Hz
- ② Ring interrupt Cycle : On/Off depending on input Ring Signal Cycle.

## 4.1.4 Scan Part

---

Pictorial signal input part: output signal of CCD passes through Bypass Cap change to ADC at HT82V26, and defined signal between HT82V26 and CHORUSm processes the Image signal. When AFE accept each pixel, CDS(Correlated Double Sampling) technique which samples arm-level twice is used on each pixel by using CIP4e signal.

2) Pictorial image processing part: read CCD Pixel data in terms of 600dpi Line and process Error Diffusion Algorithm on Text mode and Photo mode, and then store Data at Scan Buffer on PC Scan mode without algorithm.

On every mode Shading Correction and Gamma Correction are executed ahead, then processing is executed later.

### \* Scan Image Control Specification

- ① Minimum Scan Line Time: 0.75ms
- ② Scan Resolution : Max. 600DPI
- ③ Scan Width : 216mm
- ④ main function
  - Internal 12bit ADC
  - White Shading Correction
  - Gamma Correction
  - CCD Interface
  - 256 Gray Scale

3) CCD Operating Part : CCD Image sensor use +5V and Inverter uses +24V

- CCD Maximum Operating Frequency : 10MHz
- CCD Line time : 0.75ms
- White Data output Voltage : 0.7V  $\pm$ 0.5V (Mono Copy, 0.75ms/line)
- Maximum Inverter Current : 600 mA Max.( +24V)

## 4.1.5 OPE Panel Section

---

### (1) Configuration

Operations Panel uses Main Control and separated OPE Chip Micom and work as inner program, systemic operation is serial system which exchange Data with SIO Port of Main Control. OPE Panel is approximately composed of Micom part, Matrix part and LCD.

### (2) Micom controller

Micom has ROM, RAM, I/O Port built-in and displays and lights LCD by CPU command of Main Control Part and report Key recognition Data to Main Control Board.



## 4.1.6 Printer Section

Printer is consisted of the Engine parts and F/W , and engine parts is consisted of the mechanical parts comprising Frame, Feeding, Developing, Driving, Transferring, Fusing, Cabinet and H/W comprising the main control board, power board, operation panel, PC Interface.

The main controller is consisted of ASIC (CHORUSm) parts, Memory parts, Engine

Interface parts and it functions as Bus Control, I/O Handling, drivers & PC Interface by CPU.

The Engine Board and the Controller Board are in one united board, and it is consisted of CPU part and print part in functional aspect. The CPU is functioned as the bus control, I/O handling, drivers, and PC interface. The main board sends the Current Image, Video data to the LSU and manages the conduct of Electro photography for print - ing. It is consisted of the circuits of the motor (paper feed, pass) driving, clutch driving, pre-transfer lamp driving, current driving, and fan driving.

The signals from the paper feed jam sensor and paper empty sensor are directly inputted to the main board.

Printing Method:	Laser-based Electro-photography
Supported Operating Systems:	Windows 98/2000/2003/NT4.0/ME/XP/ MAC (English only, no status monitor, web download only)Linux: Red Hat 8.0~9.0, Fedora Core 1~3, Mandrake 9.0~10.2, SuSE 8.2~9.2
Emulation:	SPL(GDI) , PCL6, PS3,PCL5e
Maximum Paper Size:	Legal
Effective Printing Width:	Letter/Legal:           208mmA4:                   202mm
Resolution: (selectable from Print Driver)	Addressable 1200 x1200 dpi600x600 dpi (True; no RET)
Speed:	27ppm (Letter)
Input Paper Capacity:	Tray: 250 sheets (20 lb) Bypass: 50 sheets (20 lb)
Output Paper Capacity:	150 sheets (20 lb; sequenced 1 to N, face down)
Feed Direction:	Front In, Front Out (FIFO)
PC Interface:	USB 2.0(without HUB mode) Requires 6 ft. USB Cable (not supplied by SEC)
Toner Cartridge:	Toner Low Sensor: None Toner Low Indicator: Message displayed on LCD Cartridge Missing Indicator: Message displayed on LCD
Paper Sensing:	Tray: "Add Paper" message displayed on LCD Bypass: "Add Paper" message displayed on LCD

## ASIC

Items	Specification	Remark
Process	0.13um (STDH150)	
Package	- 496 PBGA (total pad number:597ea) - Function pin: about 367pins - PWR & GND pin: 130pins ( (130/496) × 100 = 26.2 %) - PWR & GND pad: 204ea ((204/597) × 100 = 34.17%)	*PWR & GND pin : 114ea*Dedicated PWR & GND pin(ring, rtc, lvds, pll): 16ea
Voltage	- Core Voltage: 1.2V - I/O Pad Voltage: 3.3V ?RTC Voltage : 3V	
CPU Core	ARM 920T (I-Cache: 16KB, D-Cache-16KB)	
Operating Freq.	- CPU Core: over 300MHz - Target System Bus: 100MHz	
SDRAMC	- 32 Bits Only, 100MHz - 5 Banks (Up to 128MB per Bank) - Feed-back clock(for SDRAM read) is appended	
ROMC	4 Banks (Up to 16MB per Bank)	
IOC	6 Banks (Up to 16MB per Bank)	
DMAC	6 Channels (if not use CIP4e, 4ch is available for external DMA. if CIP4E used (a4 DMA channel use), 2ch available for external DMA)	
HPVC	- Dual / Single Beam - LVDS Pad (VDO, HSYNC) - Support A4 600dpi, multi-pass color.	
PVC	- Dual / Single Beam - LVDS Pad (VDO, HSYNC) - Support A3 1200dpi, multi-pass color.	
UART	5 Channels (Channel0 supports DMA/interrupt Operation )	
INTERRUPT	6 External Interrupts, 26 Internal Interrupts	
TIMER	6 System Timers	
CIP4e	-300/400/600/1200dpi CIS/CCD image sensor interface -Color/Mono grey image, Binary image scan support -600dpi Color/Mono Copy support -Image processing for High-End MFP, Digital Copier, -MH/MR/MMR CODEC function for fax - Scan image :(max) A4 1200dpi pixel processing, -Copy image :(max) A4 600dpi pixel processing	
NAND Flash Controller	- 8/16 Bits, H/W ECC Generation - Auto Boot Mode (using internal SRAM, 4KB)	
MAC	- 10M/100Mbps - Full IEEE 802.3 compatibility	
PPI	IEEE1284 compliant parallel port interface	
GEU	Graphic Execution Unit	

Items	Specification	Remark
RSH	Fully Hardware Rotator/Scaler/Halftoner support	
Engine Controller	<ul style="list-style-type: none"><li>- LSU Interface unit, contained APC function.</li><li>- Step Motor: 4 Phase</li><li>- PWM: 8 Channels</li><li>- ADC: 8 Channels</li><li>- BLDC clock support.</li></ul>	
APC	DAC(2 ea)	
I2C Controller	I2C bus(SM bus) Slave Device Support (I2C Version 2.1)	
RTC	RTC Core Voltage: 3V	
PLL	2 PLL (MAIN / (H)PVC )	

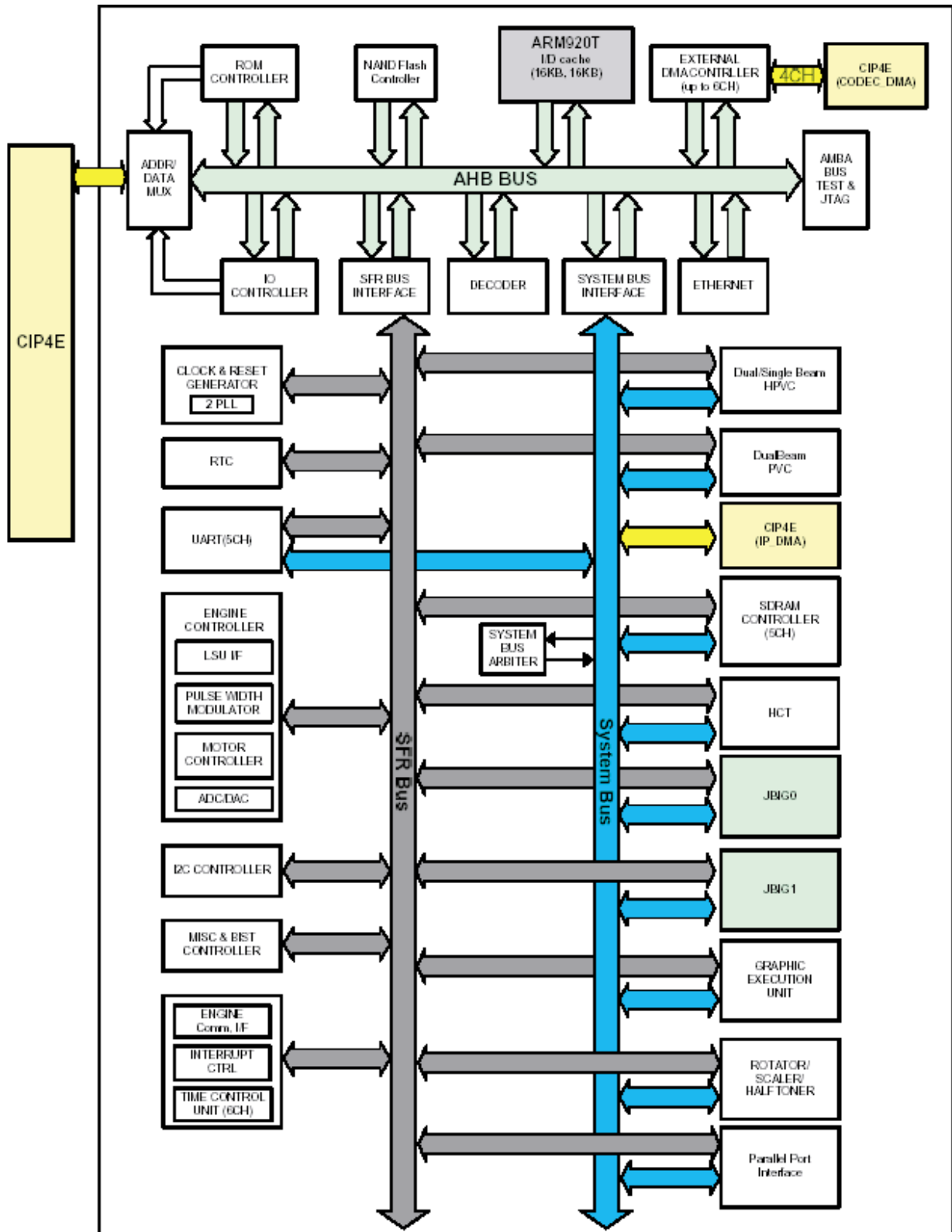

## 4.1.7 Copier Section

Copy Mode:	Black and White
Scanner Type; Maximum Size of Original: (max. width = 218 mm, max length =400 mm)	CCD with Flatbed/Platen and ADF Platen: 216 x 297 mm ADF: Legal (216 x 356 mm)
Optical Resolution:	600 x 600 dpi
Copy Quality - H x V: (User selectable via Content button)	Text : 600 x 300 dpi (default) Text/Photo : 600 x 300 dpi Photo : 600 x 600 dpi
Supported Media Types: Copy Speed: (SDMP = Single Document, Multiple Printout, MDSP = Multiple Document, Single Printout)	Plain, Label, Cardstock, Transparency Platen, SDMP: 27cpm (Letter) ADF, SDMP: 27cpm (Letter) ADF, MDSP: 14cpm (Letter, Text or Text/Photo) 8cpm (Letter, Photo)
Reduce/Enlarge:	Platen: 25% - 400% (1% increments) ADF: 25% - 100% (1% increments)
Non-printable Area: Copy Count: (Page count displayed on LCD during copy operation)	4 mm (Top, Bottom, and each Side) 1 to 199
Copy Modes:	Text, Text/Photo, Photo
Fixed R/E Setting:	100%, Auto-fit, 2(4)-Up
Darkness Control:	5 levels
First Copy Output Time (FCOT):	Platen: 10 sec. (600 x 300 dpi) ADF: 15 sec. (600 x 300 dpi)
Duplex Copy	Automatic Duplex Copy for 1815dn model

## 4.1.8 Telephone Section

Speed Dial:	400 Locations (46 digits maximum per location)
On-hook Dial (manual fax):	Yes
Last Number Redial:	Yes
Automatic Redial:	Yes
Pause:	Yes (using Redial key)
Ringer Volume:	Off, Low, Medium, High
Tone/Pulse:	Selectable (Tech Mode Only no Telecom certification for Pulse mode)

## 4.1.9 SMPS & HVPS SECTION

The SMPS supplies DC Power to the System.

It takes 110V/220V and outputs the +5V, +24V to supply the power to the main board and ADF board. The HVPS board creates the high voltage of THV/MHV/Supply/Dev and supplies it to the developer part for making best condition to display the image. The HVPS part takes the 24V and outputs the high voltage for THV/MHV/BIAS, and the outputted high voltage is supplied to the toner, OPC cartridge, and transfer roller.

### HVPS (High Voltage Power Supply)

- Transfer High Voltage (THV+)
  - Input Voltage: 24 V DC  $\pm$  15%
  - Output Voltage: MAX +5.0KV Duty Variable,  
-1.2KV  $\pm$  15% ()
  - Output Voltage Trigger: 6.5  $\mu$ A
  - Line Regulation : under  $\pm$ 3% (fluctuation input 21.6V ~ 27.6V)
  - Output Voltage Rising Time 50ms Max
  - Output Voltage Falling Time : 100 ms Max
  - Fluctuating transfer voltage with environmental various : +650 V(Duty 10%) ~ 5 KV (Duty 90%)
  - Environment Recognition Control Method : The THV-PWM ACTIVE is transfer active signal. It detects the resistance by recognizing the voltage value, F/B, while permits the environmental recognition voltage.
  - Output Voltage Control Method : Transfer Output Voltage is outputted and controlled by changing Duty of THVPWM Signal. 10% Duty : +650V, 90% Duty : +5KV

· Charge Voltage (MHV)

- Input Voltage : 24 V DC  $\pm$  15%
- Output Voltage : -1.2KV ~ -1.8KV DC  $\pm$  3%
- Output Voltage Rising Time : 50 ms Max
- Output Voltage Falling Time : 50 ms Max
- Output Control Signal(MHV-PWM) : CPU is HV output when PWM is Low

· Cleaning Voltage (THV-)

- The (+) Transfer Voltage is not outputted because the THV PWM is controlled with high.
- The (-) Transfer Voltage is outputted because the THV-Enable Signal is controlled with low
- The output fluctuation range is big because there is no Feedback control.

· Developing Voltage (DEV)

- Input Voltage : 24 V DC  $\pm$  15%
- Output Voltage: -200V ~ -600V DC  $\pm$  3%
- Output Voltage Fluctuation Method : PWM Control
- Line Regulation : under  $\pm$ 3% (fluctuation input 21.6V ~ 27.6V)
- Load Regulation : Under  $\pm$ 3%
- Output Voltage Rising Time : 50 ms Max
- Output Voltage Falling Time : 50 ms Max
- Output Control Signal (BIAS-PWM) : the CPU output is HV output when PWM is low .

· Supply

- Output Voltage : -300V ~ -800V DC  $\pm$  5% (ZENER using, DEV )
- Line Regulation : under  $\pm$ 3% (fluctuation input 21.6V ~ 27.6V)
- Load Regulation : Under  $\pm$ 3%
- Output Voltage Rising Time : 50 ms Max
- Output Voltage Falling Time : 50 ms Max
- Output Control Signal (BIAS-PWM) : the CPU is HV output when PWM is low .

**SMPS (Switching Mode Power Supply)**

It is the power source of entire system. It is assembled by an independent module, so it is possible to use for common use. It is mounted at the bottom of the set.

It is consisted of the AMPS part, which supplies the DC power for driving the system, and the AC heater control part, which supplies the power to fuser. SMPS has two output channels. Which are 3.3V and +24V.

· AC Input

Input Rated Voltage: AC 115V ~ 127V / AC 220V ~ 240V AC 120V / AC 220V(EXP version)

Input Voltage fluctuating range : AC 198V ~ 264V AC 90V ~ 135V / AC 198V ~ 264V

(EXP version)

Rated Frequency : 50/60 Hz

Frequency Fluctuating range : 47 ~ 63 Hz

Input Current : Under 5.0Arms / 2.5Arms (But, the status when lamp is of f or rated voltage is inputted/ outputted )

· Rated Output Power

NO	ITEM	CH1	CH2	Remark
1	CHANNEL NAME	+5V	+24.0V	
2	CONNECTOR PIN	CON 3 5V PIN: 11,13,15 GND PIN: 12,14,16	CON 3 24V PIN:3,5,7,9 GND PIN:4,6,8,10	
3	Rated Output	+5V ±5% (4.75 ~5.25V)	+24V ±10% (21.6 ~26.4V)	
4	Max. Output Current	3 A	4.4 A	
5	Peak Loading Current	3.6 A	5.3 A	1ms
6	RIPPLE NOISE Voltage	100mVp-p@ ō	Under 500mVp-p	
7	Maximum output	15W	105.6W	
8	Peak output	18W	127.2W	1ms
9	Protection for loading shortage and overflowing current	Shut down or Fuse Protection	Shut down or Output Voltage Drop	

· Consumption Power

NO	ITEM	CH2(+5V)	CH3(+24V)	System
1	Stand-By	TBD A	TBD A	AVG : TBD Wh
2	PRINTING	TBD A	TBD A	AVG TBD Wh
3	Sleep-Mode	TBD A	TBD A	AVG : TBD Wh



- Length of Power Cord : 1830 ±50mm
- Power Switch : Use
- Feature
  - Insulating Resistance : 100 MΩ or more (at DC 500V)
  - Withstanding Voltage : Must be no problem within 1 min. (at 1000V -LV model / 1500Vac-HV model,10mA)
  - Leaking Current : under 3.5mA
  - Running Current : under 40A PEAK (AT 25 °C, COLD START)  
under 60A PEAK (In other conditions)
  - Rising Time : within 2Sec
  - Falling Time : over 20ms
  - Surge : Bi-Wave 3kV ? Normal, 6KV - Common

- Environment Condition

- Operating temperature range : 0 °C ~40 °C
- Maintaining temperature range : -25 °C ~85 °C
- Preserving Humidity Condition : 30% ~90% RH
- Operating atmospheric pressure range : 1atm

- EMI Requirement : CISPR ,FCC, CE, MIC

- Safety Requirement :IEC950 UL1950, CSA950, C-UL,NOM,TUV ,Semko,EK,CB, GOST, EPA, Power save

- FUSER AC POWER CONTROL

Fuser(HEAT LAMP) gets heat from AC power. The AV power controls the switch with the Triac, a semiconductor switch. The ON/OFF control is operated when the gate of the Triac is turned on/off by Phototriac (insulating part).

In other words, the AC control part is passive circuit, so it turns the heater on/off with taking signal from engine control part.

When the HEATER ON signal is turned on at engine, the LED of PC501 (Photo Triac) takes the voltage and flashes. From the flashing light, the Triac part (light receiving part) takes the voltage, and the voltage is supplied to the gate of Triac and flows into the Triac. As a result, the AC current flows in the heat lamp, and heat is occurred.

On the other hand, when the signal is off, the PC501 is off, the voltage is cut off at the gate of Triac, the Triac becomes off, and then the heat lamp is turned off.

- Triac (Q501) feature : 24A-LV model / 16A-HV model, 600V SWITCHING

- Phototriac Coupler (PC501)

- Turn On If Current : 15mA ~50mA(Design: 16mA)
- High Repetive Peak Off State Voltage : Min 600V

### 4.1.10 Toner Cartridge

---

In the toner cartridge, the OPC unit and the developer unit are in a body .

The OPC unit has OPC drum and charging roller , and the developer unit has toner , toner cartridge, supply roller, developing roller, and the blade.

### 4.1.11 LSU (Laser Scanner Unit)

---

The LSU unit is controlled by video controller . It scans the video data received from video controller with laser beam by using the rotation principle of the polygon mirror to create the latent image on the OPC drum. It is the core part of LBP .

The OPC drum rotates as the same speed as the paper feeding speed. It creates the /HSYNC signal and sends it to the engine when the laser beam of the LSU reaches the end of the polygon mirror , and the engine detects the /HSYNC signal to arrange the vertical line of the image on the paper . After detecting the /HSYNC signal, the image data is sent to the LSU to arrange the its margin on the paper .

The one side of the polygon mirror is one line for scanning.

### 4.1.12 Fixing Part (FUSER)

---

The fuser is consisted of the Heat Lamp, Heat Roller , Pressure Roller, Thermistor and Thermostat.

It adheres the toner to the paper with pressure and a heat to complete the printing job.

### 4.1.13 TRANSFER Ass'y

---

It is consisted of PTL (pre-transfer lamp) and Transfer Roller. The PTL sends a light to the OPC drum, makes the current on the drum surface to low, and improve the transfer efficiency.

The transfer roller delivers the toner of the OPC drum to the paper .

### 4.1.14 Driver Ass'y

---

- It is a power delivery unit by gearing: BLDC Motor(P62) -> Pickup/Feeder/Developer  
STEP Motor( ø55) -> Feeder/Exit  
STEP Motor( ø42) -> Duplex

## 4.1.15 Feeding Part

---

- Feeding Type: Universal Cassette Type
- Feeding Standard: Center Loading
- Feeding Qty: Cassette 250 sheets (75g/ m<sup>2</sup>, 20lb paper standard)  
Bypass 50 sheet (Paper, OHP, Envelope etc.)
- Separating Type: Cassette - Friction Pad Type  
Bypass - Friction Pad Type
- Driver Type: Driving by Gearing from Main Motor
- Pick\_up Roller Driver: Solenoid

## 4.1.16 Duty Cycle

---

(except where noted otherwise, all toner usage references are for Letter size paper at 5% coverage)

- ▶ Product Life Time : 200,000 images or 5 years, whichever comes first
- ▶ Toner CRU: Initial CRU to be 3,000 pages (In-Box): 85 grams  
After-market CRU will be 5,000 pages: 140grams
- ▶ Recommended Duty Cycle: 1,500 pages/month (A4 size ,ISO 19752 5% coverage)
- ▶ AMPV: Printing: 2,500 pages  
Flat-bed: 150 pages  
ADF: 150 pages
- ▶ Max. Monthly Volume: Printing: 25,000 pages  
Flat-bed: 1,000 pages  
ADF: 1,000 pages
- ▶ Periodic replace parts are recommended as follows:
 

CRU	ADF Rubber Pad: 20,000 pages
	ADF Pickup Roller: 80,000pages
	Pick-up Roller (Paper Tray): 150,000 pages
	Fuser Door: non periodic
	Transfer Roller: 70,000 pages
	Fuser Unit : 80,000 pages

## 5. Disassembly and Reassembly

### 5.1 General Precautions on Disassembly

When you disassemble and reassemble components, you must use extreme caution. The close proximity of cables to moving parts makes proper routing a must.

If components are removed, any cables disturbed by the procedure must be restored as close as possible to their original positions. Before removing any component from the machine, note the cable routing that will be affected.

#### Whenever servicing the machine, you must perform as follows:

1. Check to verify that documents are not stored in memory.
2. Be sure to remove the toner cartridge before you disassemble parts.
3. Unplug the power cord.
4. Use a flat and clean surface.
5. Replace only with authorized components.
6. Do not force plastic-material components.
7. Make sure all components are in their proper position.

#### Releasing Plastic Latches

Many of the parts are held in place with plastic latches. The latches break easily; release them carefully.

To remove such parts, press the hook end of the latch away from the part to which it is latched.

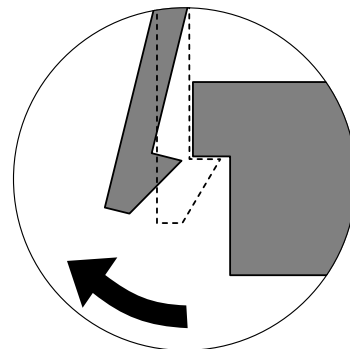

## 5.2 Front Cover

1. Take out the Cassette.

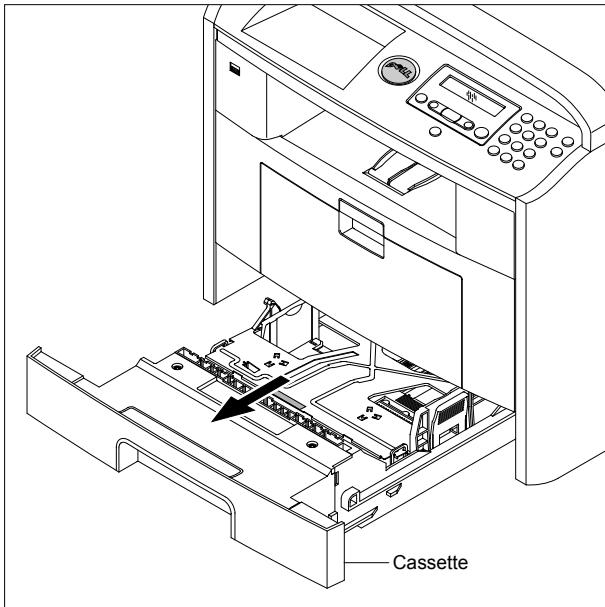

3. If necessary, remove the Toner Cartridge.

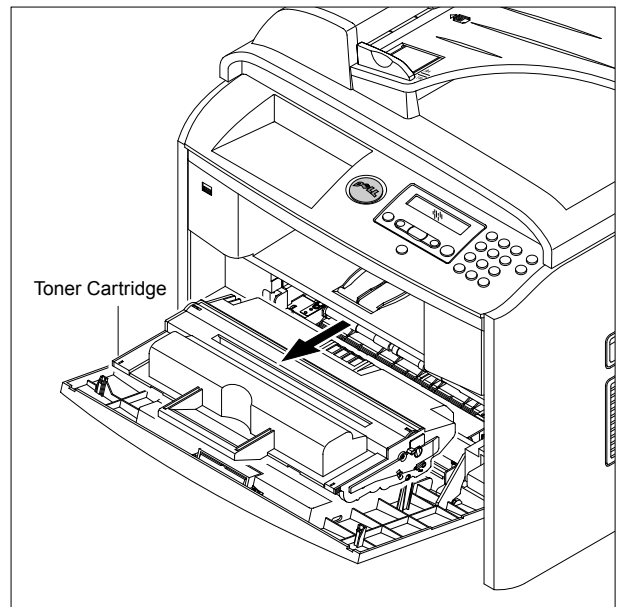

2. Open the Cover.

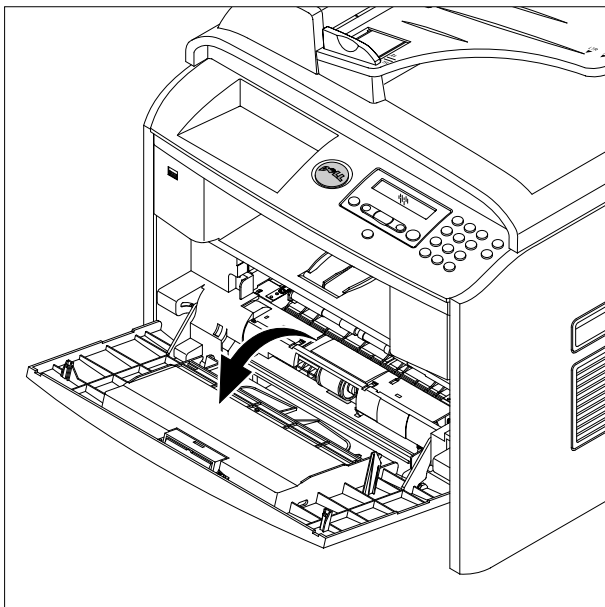

4. To remove the Front Cover, first pull the part below the both side of the Front Cover with a light pressure to the direction of arrow.

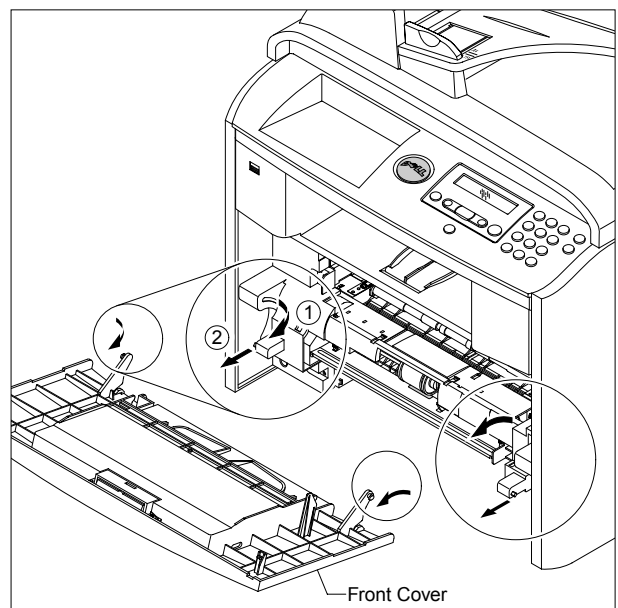

## 5.3 MP Tray Ass'y

1. Open the MP Tray Ass'y

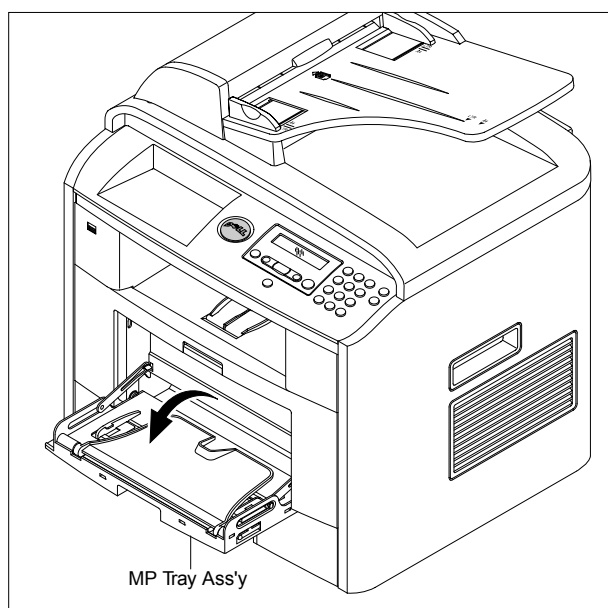

2. Pull the Tray Links from the both side of the Front Cover with a light pressure to the direction of arrow .

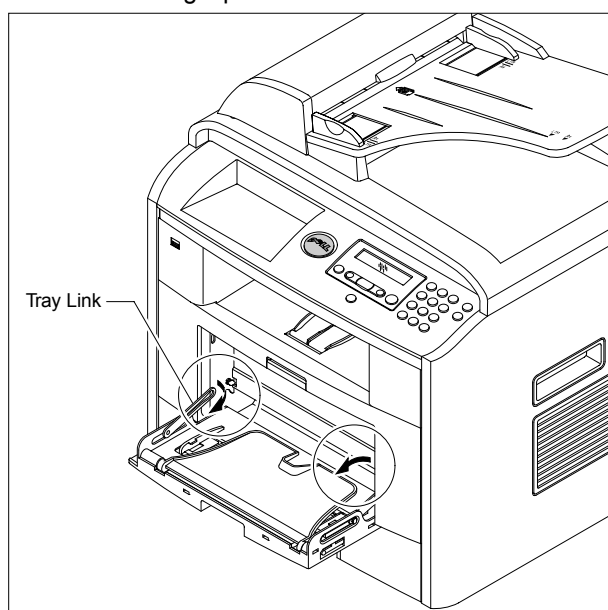

3. Apply light pressure to the both side of the MP Tray Ass'y and pull it in the direction of arrow , as shown below.

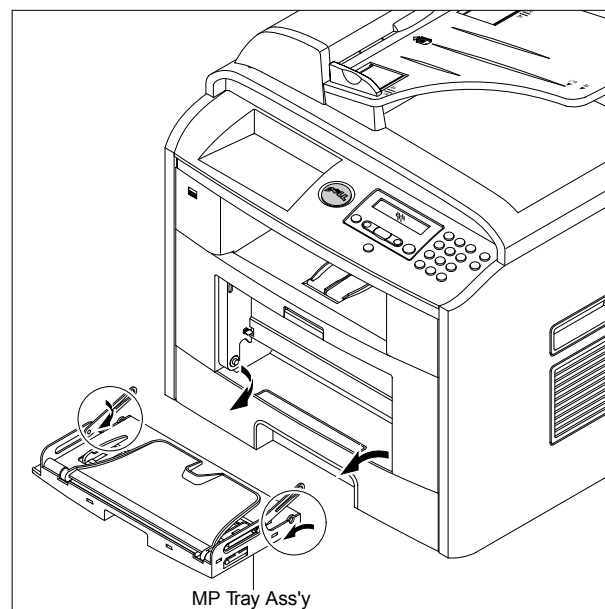

## 5.4 Rear Cover

1. Open the DIMM Cover from the Left Side Cover in the direction of arrow, as shown below.

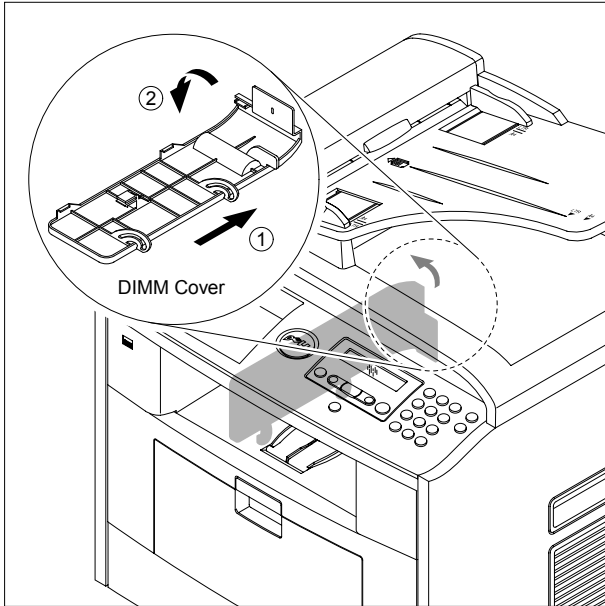

3. Remove the four screws securing the Rear Cover and then Release the Rear Cover from the Set.

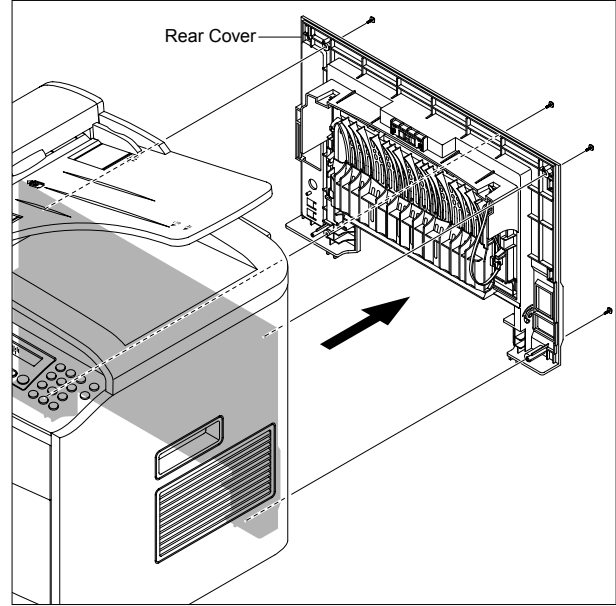

2. Take out the Duplex Unit.

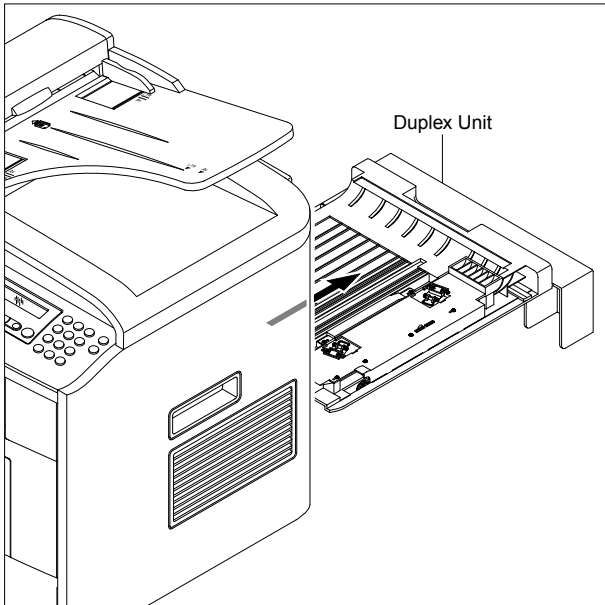

4. To remove the Face Up Cover, first release the Stopper Strap in the direction of arrow.

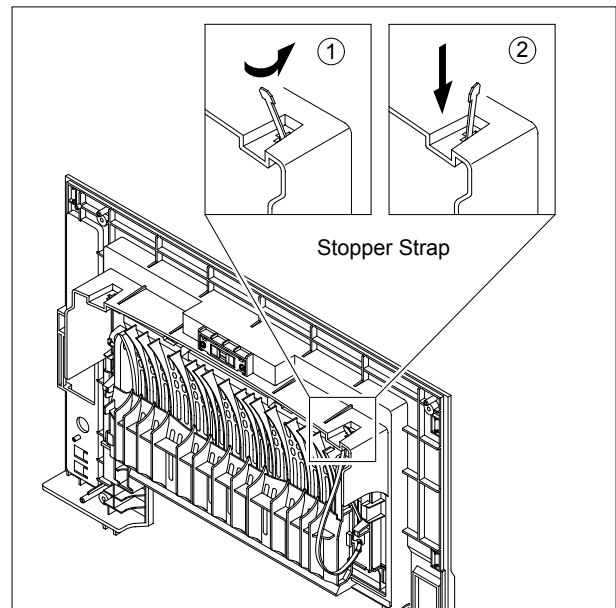

5. Unlatch the Face Up Cover from the Rear Cover and then release the Face Up Cover, as shown below.

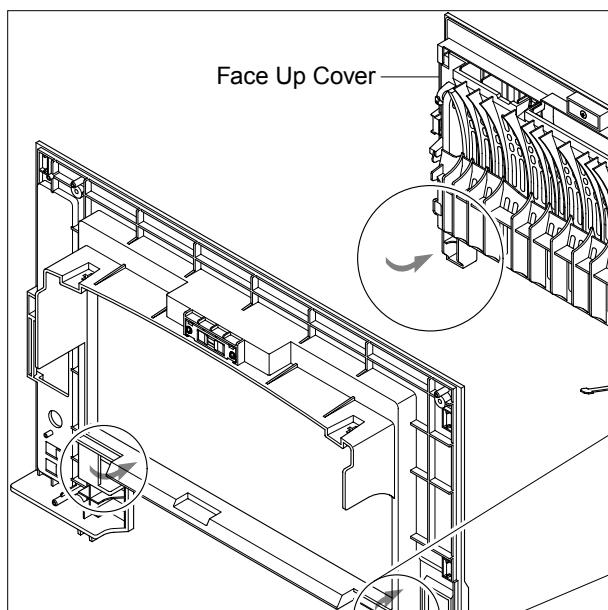



## 5.5 Fuser Ass'y

1. Before you remove the Fuser Ass'y, you should remove:
  - Rear Cover (Refer to 5.4)
2. Remove the four screws securing the Fuser Ass'y and then pull the Fuser Ass'y.

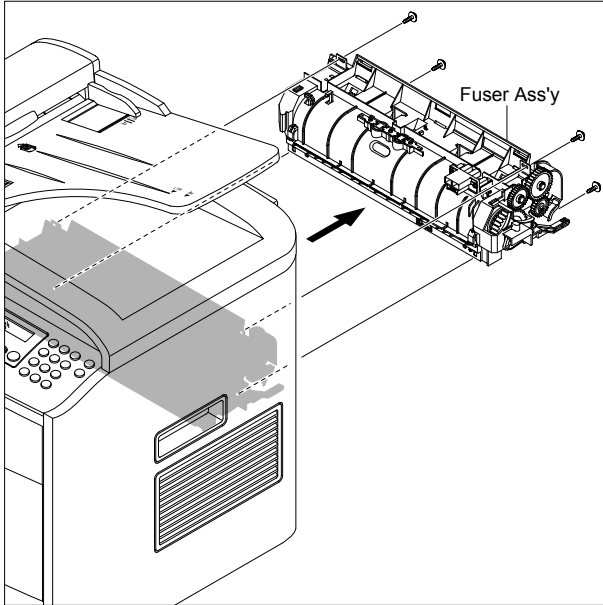

3. Release the CON Harness and REC Harness from the Thermostat and then remove the three screws securing the Thermostat and remove it.

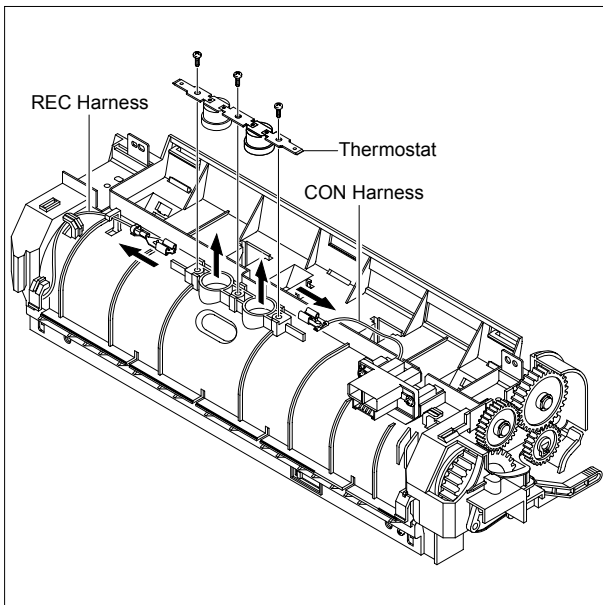

4. To remove the Halogen Lamp, first release REC Harness from the left side of the Halogen Lamp and then release the CON Harness from the right side of the Halogen Lamp, as shown below.

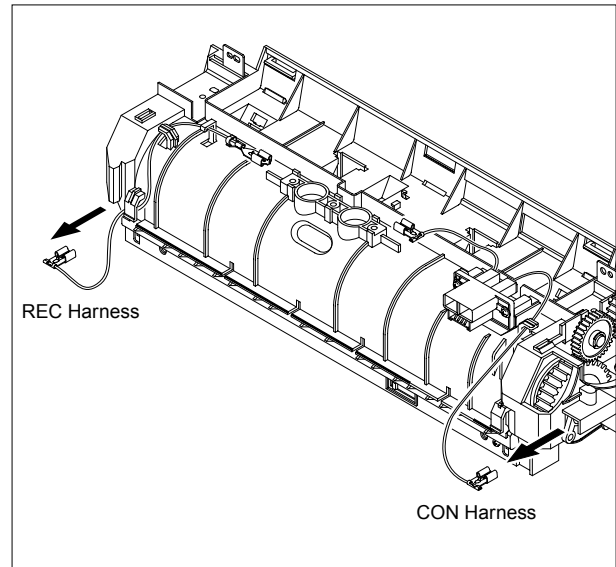

5. Remove the two screws securing the both side of the Halogen Lamp and then release in the direction of arrow, as shown below.

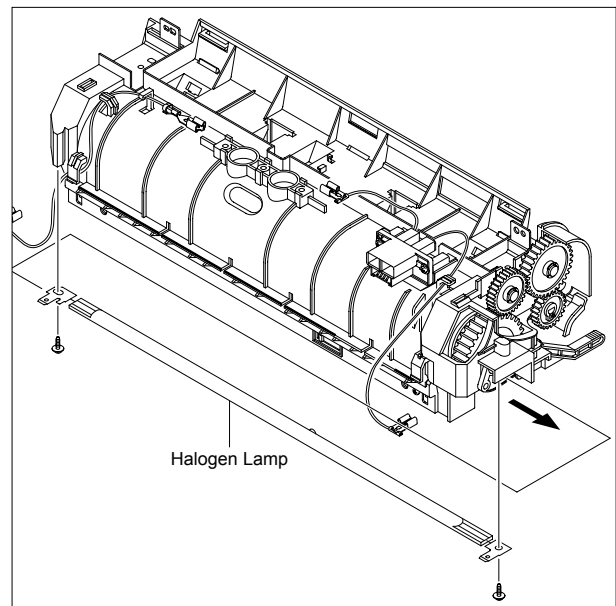

6. Remove the two screws securing the Input Guide and remove it.

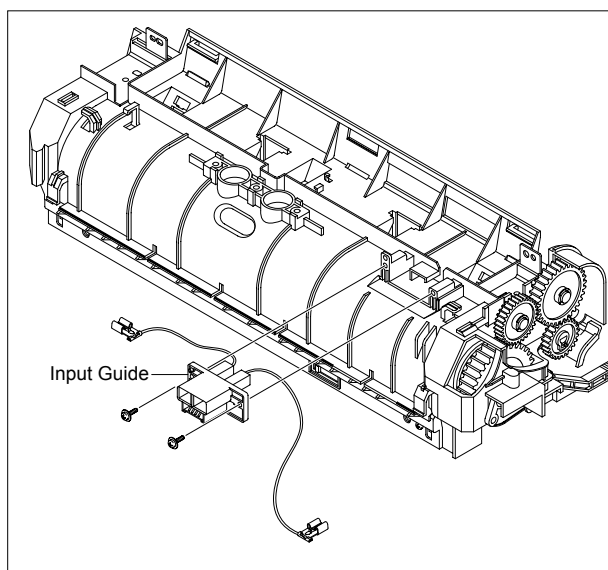

8. Remove the three screws securing the Idle Gear Bracket and remove it.

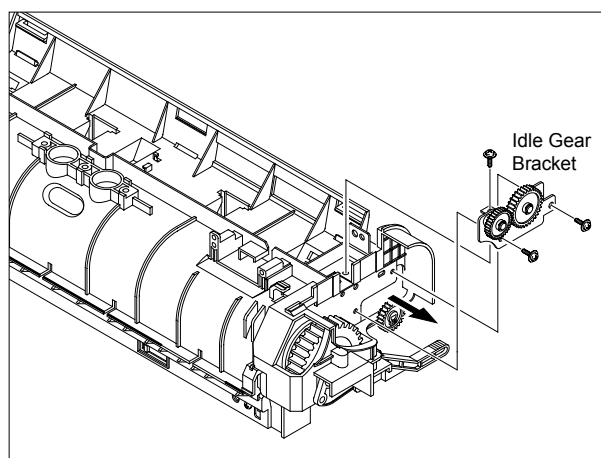

7. Unplug the connector from the Input Guide and remove the one screw securing the Thermistor and remove it.

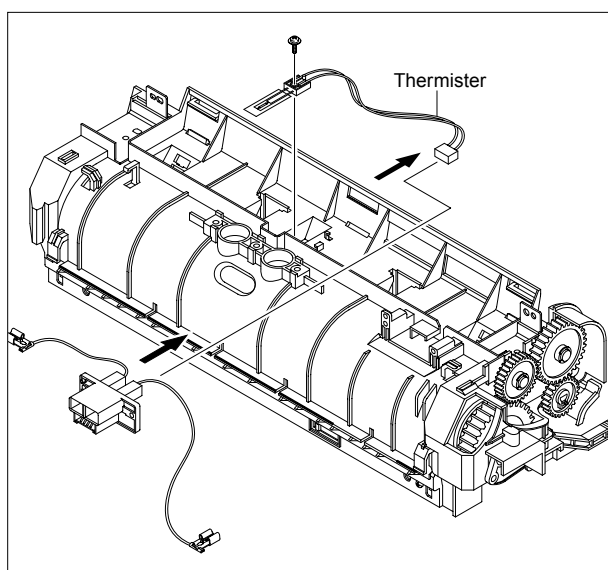

9. Remove the one screw securing the Fuser Cover and release the Fuser Cover from the Fuser Frame.

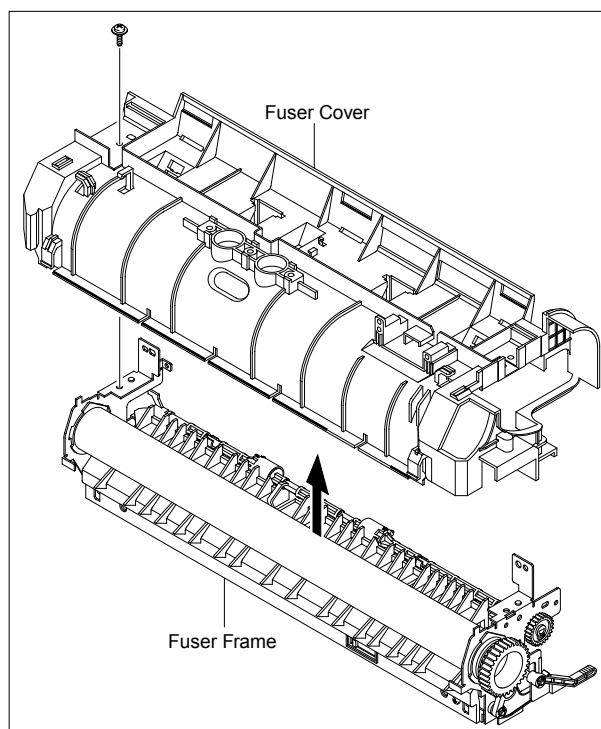

10. Release the Fuser Gear and HR Bush and then remove the Heat Roller, as shown below.

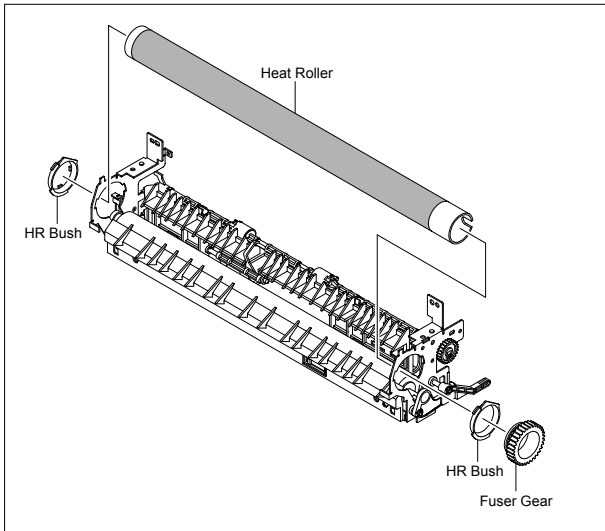

11. Remove the Jam Link Lever (L,R) and Jam Holder (L,R) and then remove the Pressure Roller, as shown below.

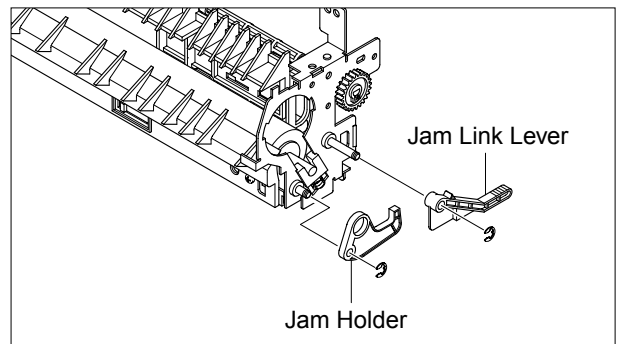
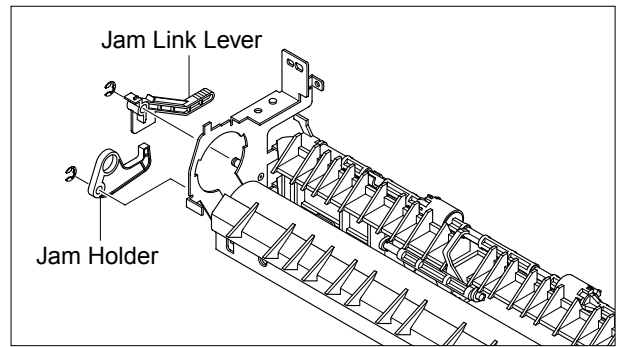

## 5.6 Side Cover (Left, Right)

1. Before you remove the Side Cover (Left, Right), you should remove:  
- Rear Cover (Refer to 5.4)

2. Remove the two screws securing the Right Side Cover, as shown below.

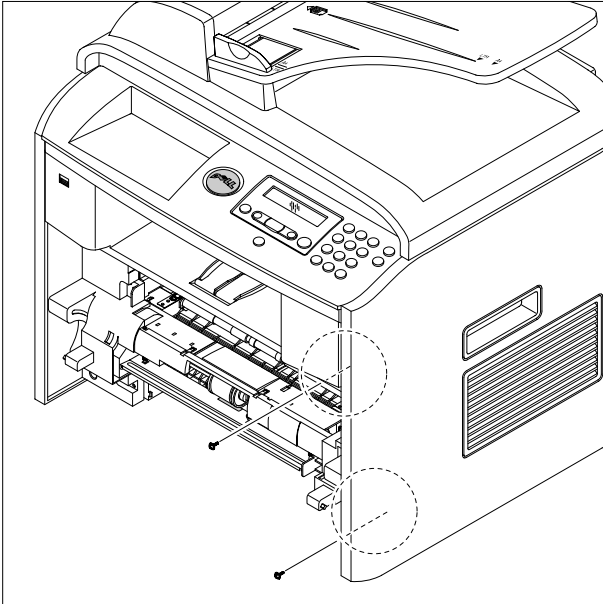

3. Apply light pressure to the bottom of the Right Side Cover and pull it to the right side in the direction of arrows, as shown below.

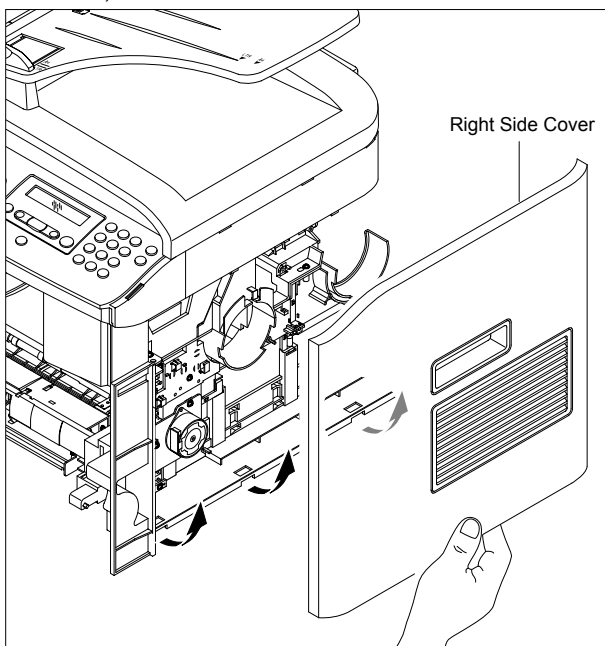

4. Remove the two screws securing the Left Side Cover, as shown below.

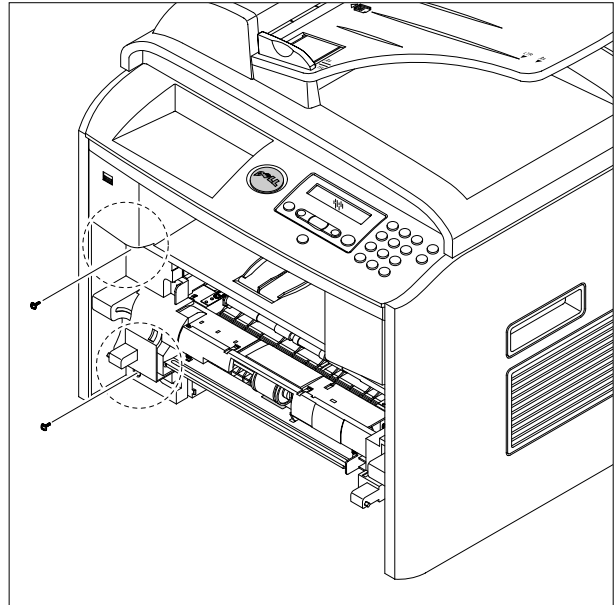

5. Apply light pressure to the bottom of the Left Side Cover and pull it to the left side in the direction of arrows, as shown below.

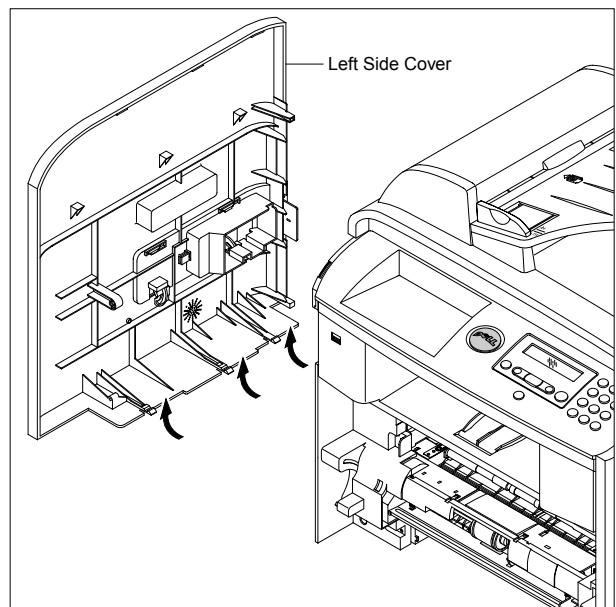

6. To remove the DIMM Cover, first open the DIMM Cover (refer to 5.4.1) and then release the DIMM Cover, as shown below.

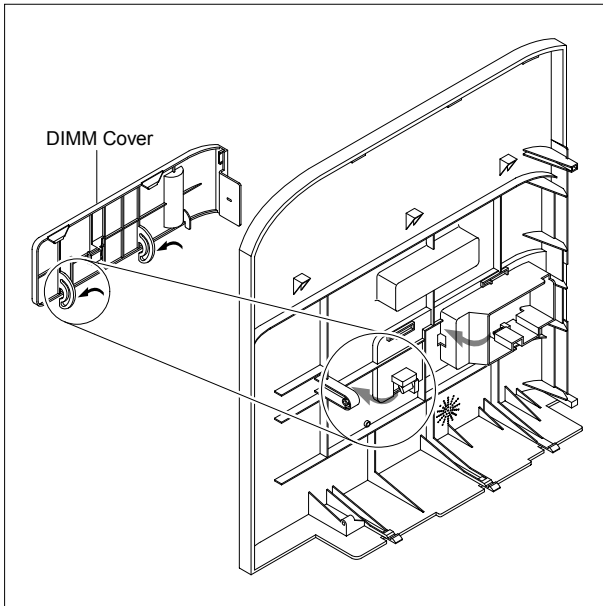

**Notice :** Be careful not to damage the hooks when remove the Side Cover (Left, Right).

## 5.7 Scanner Ass'y

1. Before you remove the Scanner Ass'y, you should remove:

- Rear Cover (Refer to 5.4)
- Side Cover (Left, Right) (Refer to 5.6)

2. Remove the two screws securing the Scanner Ass'y, as shown below.

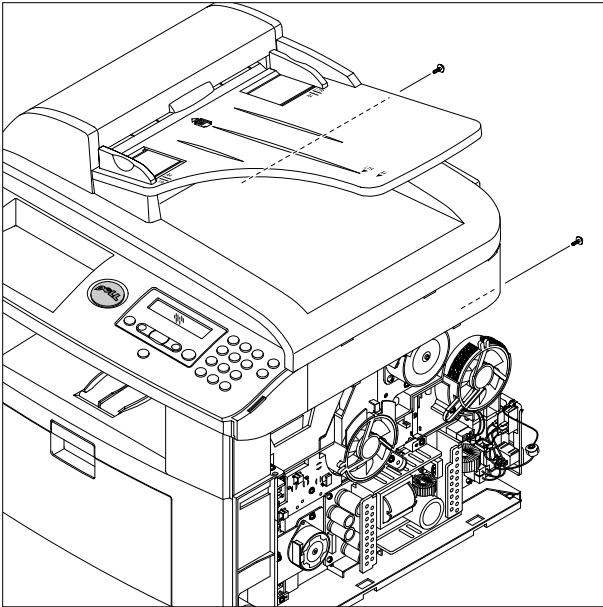

3. Remove the one screw securing the Ground Cable and unplug the four connectors and CCD Cable.

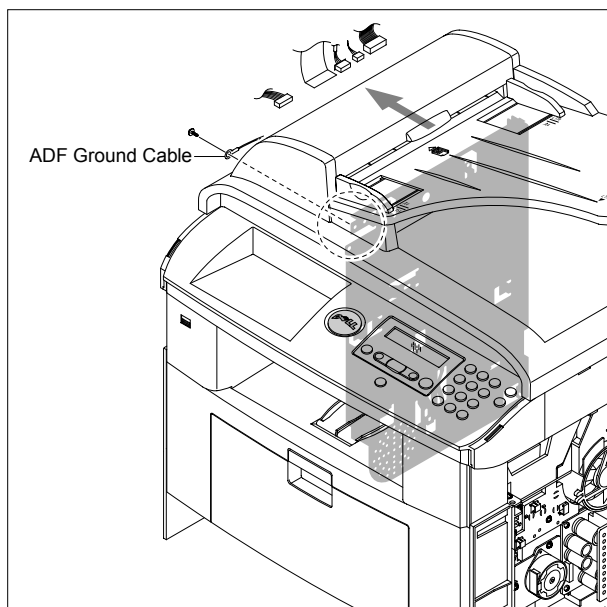

4. Pull up the Scanner Ass'y, as shown below.

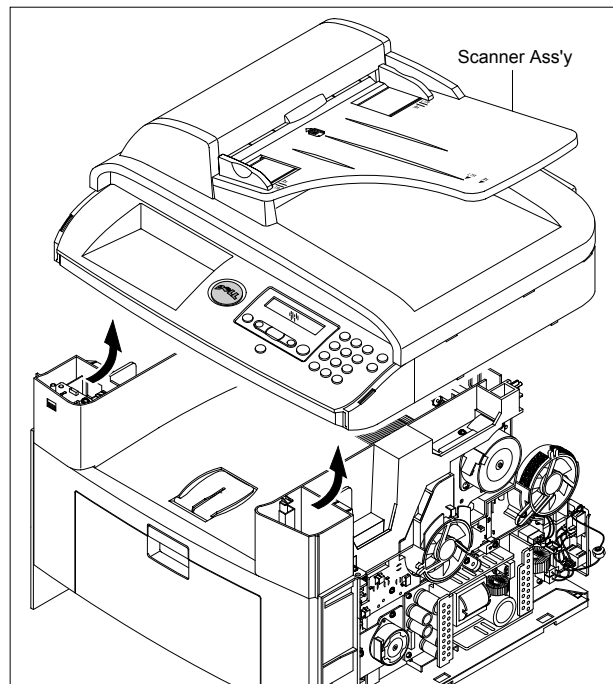

5. Release the ADF Harness from the underneath the Scanner Ass'y.

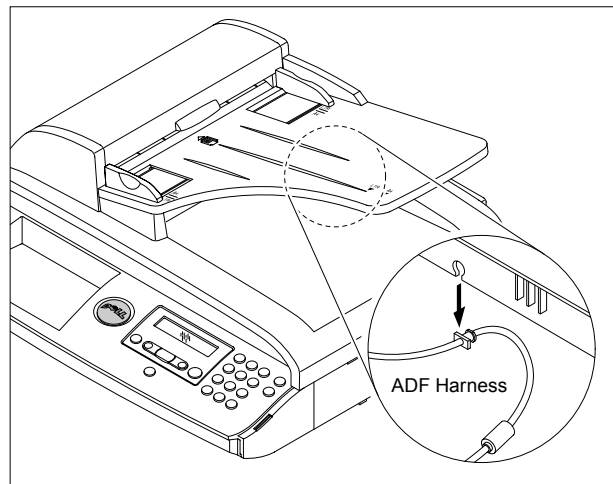

6. Lift the ADF Ass'y upward to remove it.

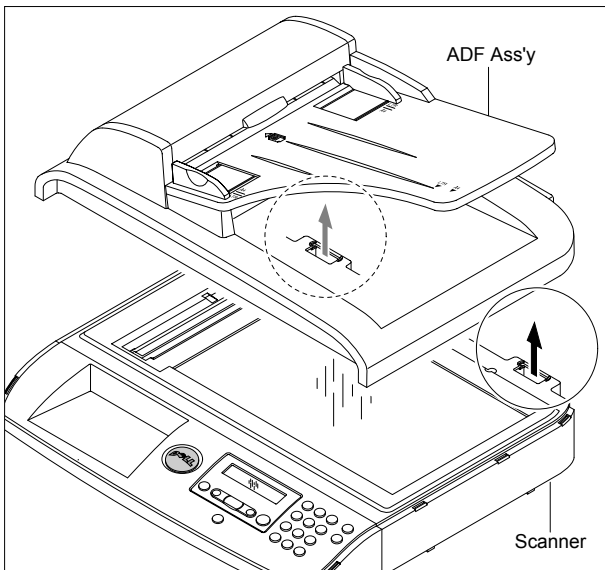

7. To remove the OPE Unit, first pull the part below the front of the OPE Unit with a light pressure to the direction of arrow.

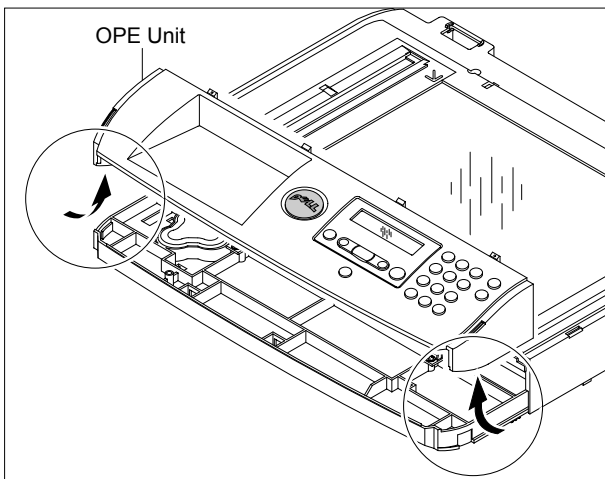

8. Unplug the three connectors from the OPE PBA, as shown below and then release the Battery.

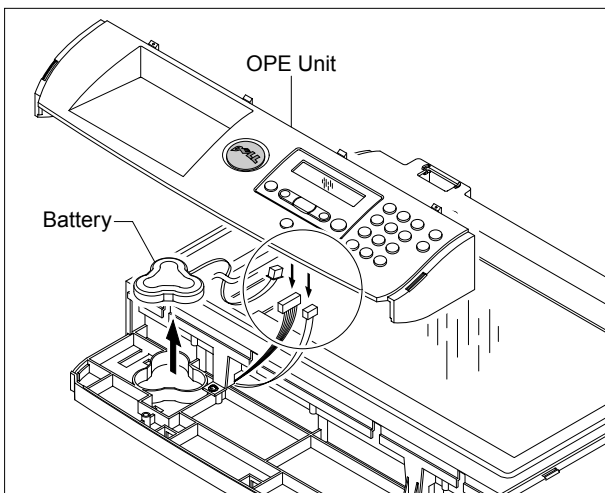

9. Remove the four screws securing the Scan Upper.

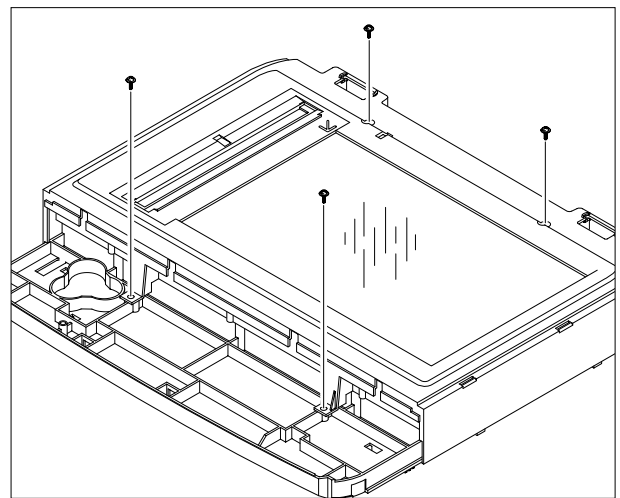

10. Release the four hooks securing the Scan Upper to the Scan Lower and remove it, as shown below.

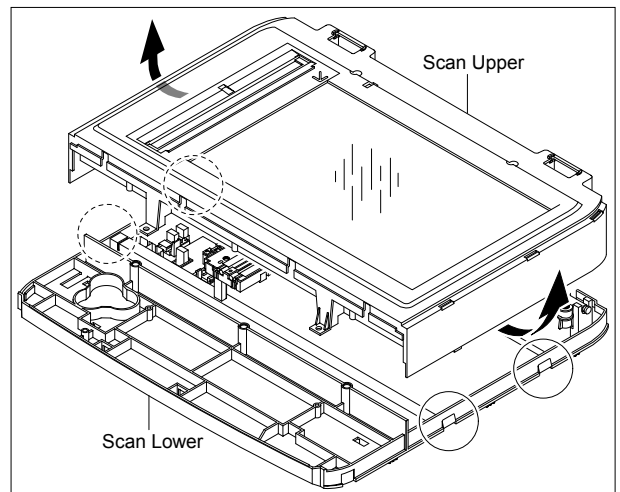

11. Remove the CCD Cable, as shown below.

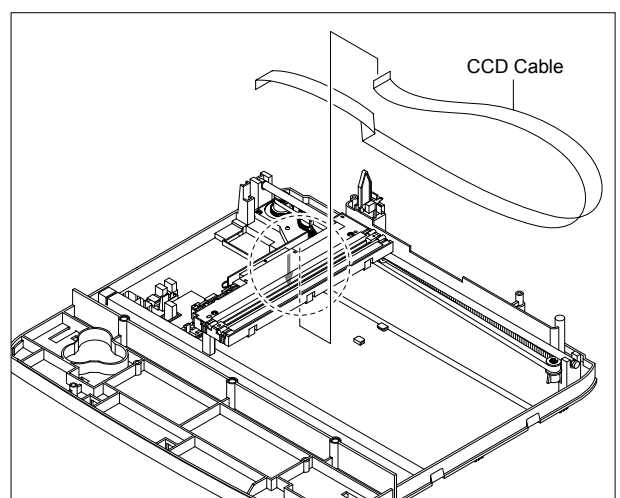

12. Pull up the CCD Shaft and take out the CCDM.

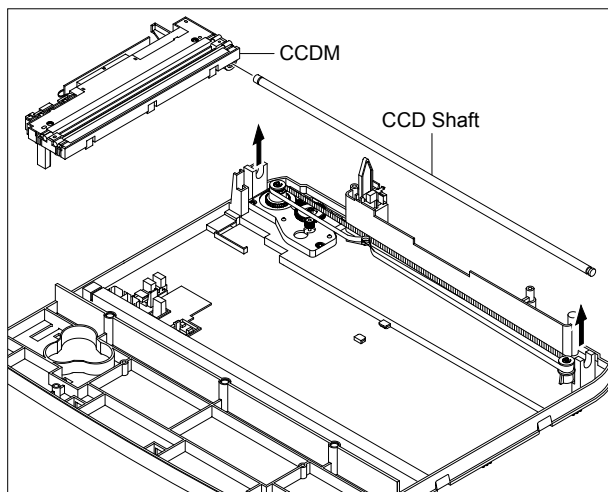

13. Squeeze the spring to release the tension in the Belt and lift from the pulleys, as shown below.

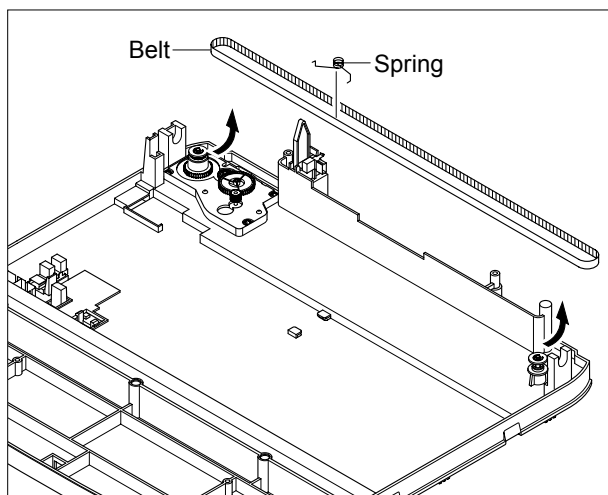

14. Remove the three screws securing the Scan Motor Ass'y and remove it.

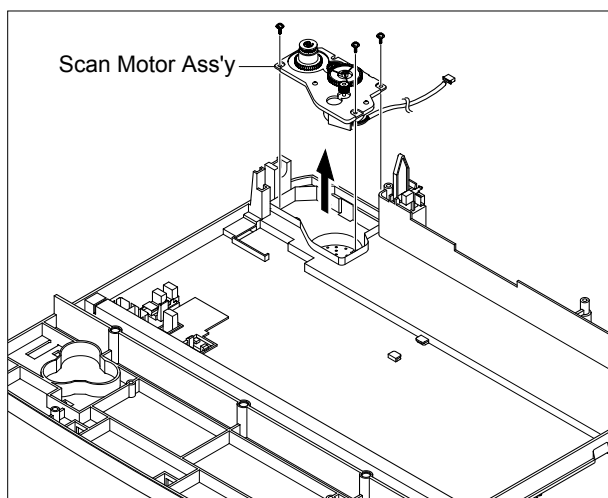

15. If necessary, remove the two screws securing the Scan Motor and remove it, as shown below.

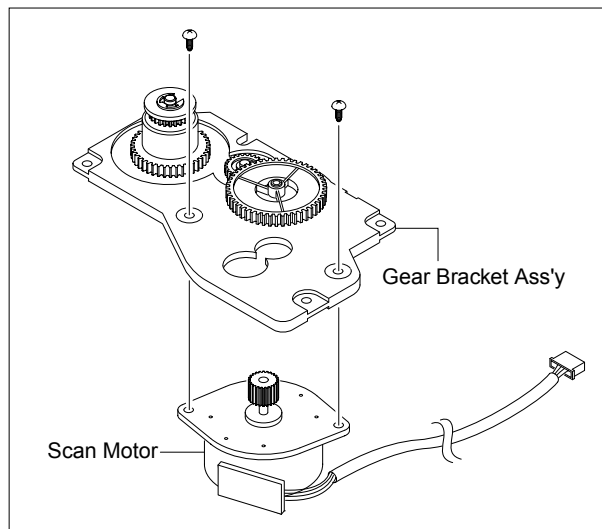

**Caution : Reassembling CCDM**

- 1) When refitting the Scanner Belt and Belt Spring take care to relocate the tension spring as close to the right side of the CCDM as is possible, as shown below.
- 2) When refitting the Scan Upper Cover take care to ensure that the Cover Open Switch is not trapped.

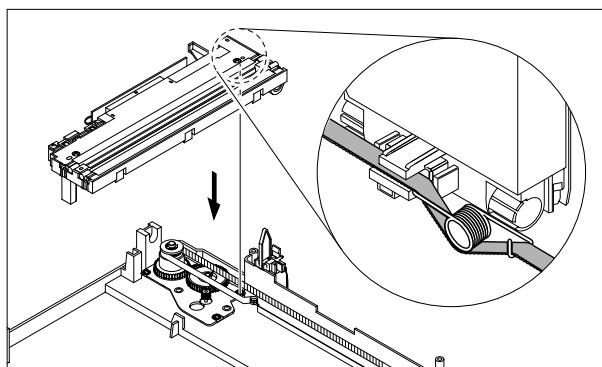



16. Unplug the connector from the Open Sensor Ass'y.

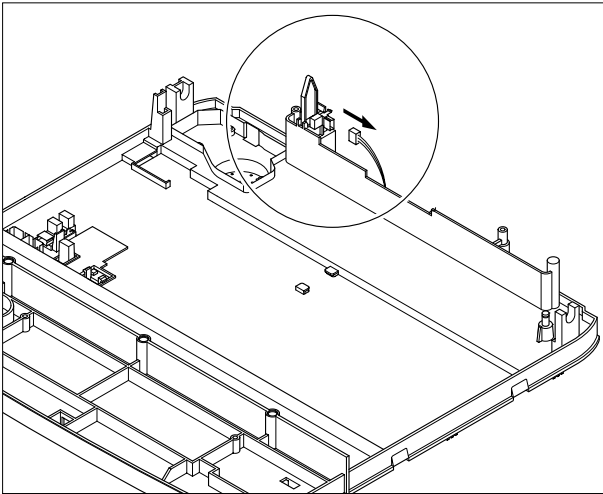

17. Unlatch the Open Sensor and remove it, as shown below.

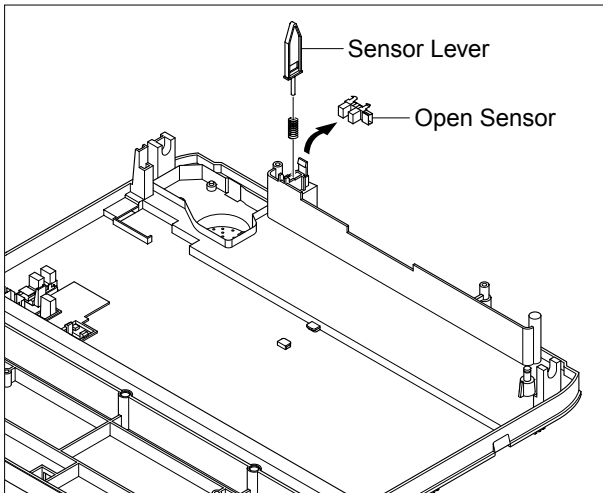

18. Remove the CCD Holder.

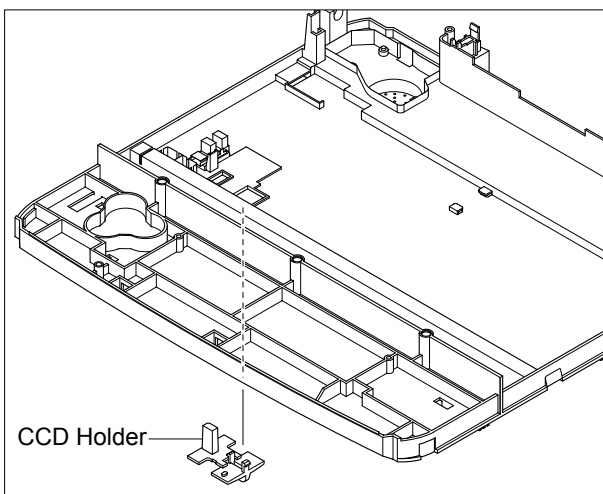

19. Unplug the Harness from the CCD Home Sensor and release the CCD Home Sensor, as shown below.

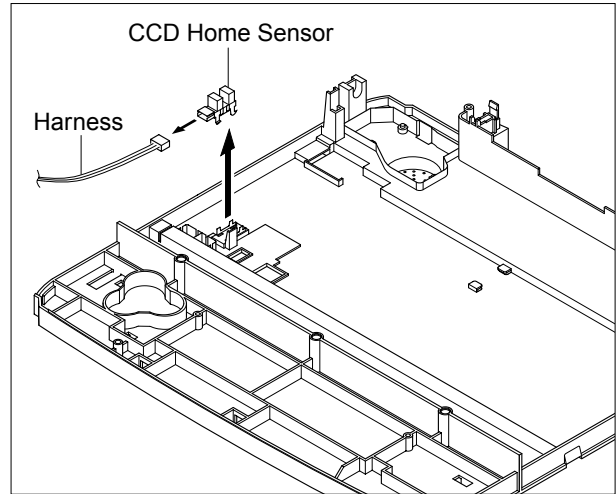

## 5.8 ADF Ass'y

- Before you remove the ADF Ass'y, you should remove:
  - Rear Cover (Refer to 5.4)
  - Side Cover (Left, Right) (Refer to 5.6)
  - Scanner Ass'y (Refer to 5.7)
- Release the ADF Harness from the underneath the Platen Cover Ass'y.

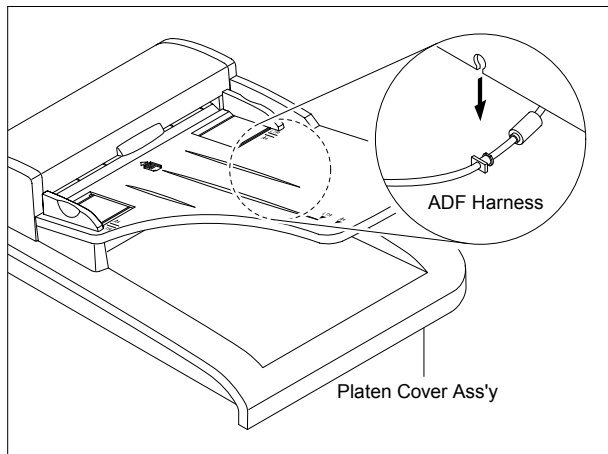

- Remove the two screws securing the ADF Engine Ass'y and remove it.

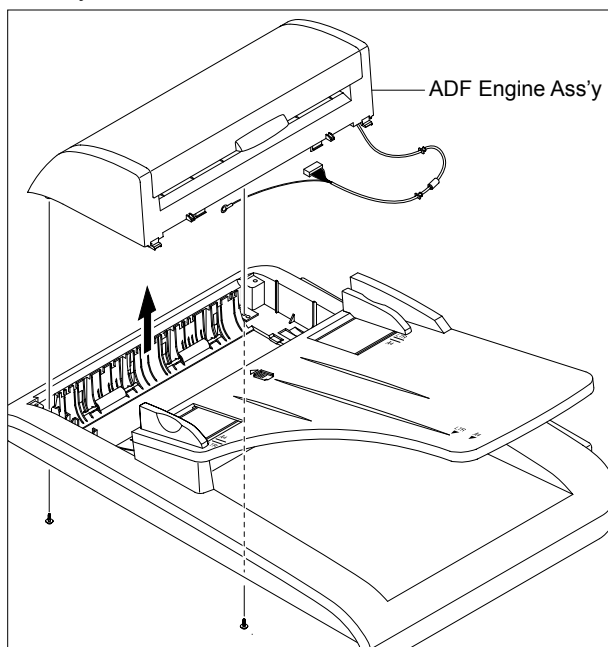

**Notice :** Take care to thread the ADF Harness through the Platen Cover Ass'y.

- Remove the Open Cover, as shown below.

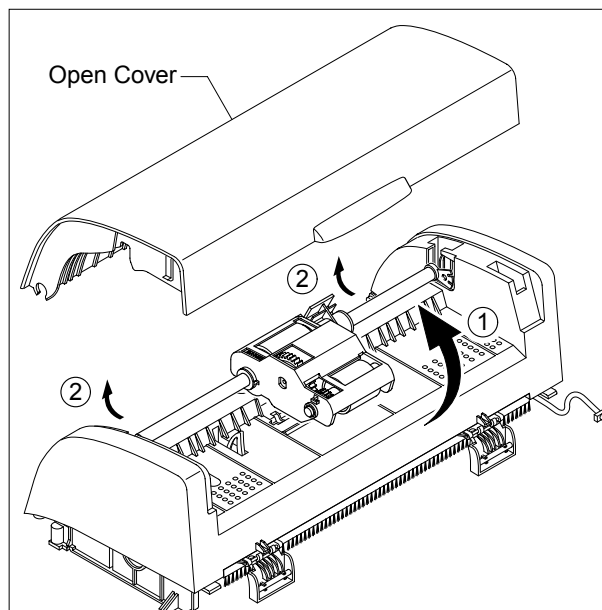

**Notice :** When working on the ADF Motor Ass'y take care not to contaminate any of the rubber surfaces with grease.

- Release the Bush and rotate it until it reaches the slot, as shown below. Then lift the Pick Up Ass'y out.

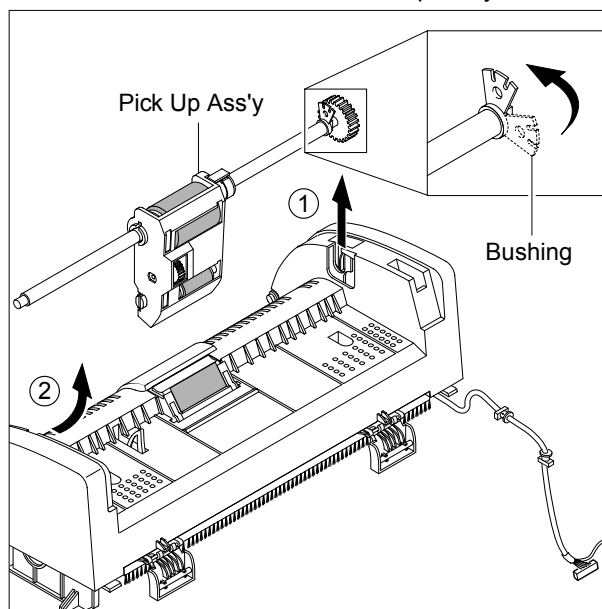

6. Remove the two screws securing the ADF Upper and remove it, as shown below.

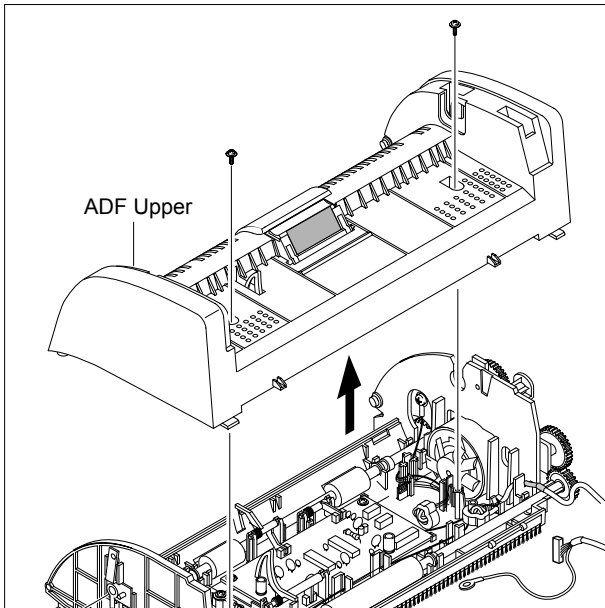

7. Unplug the one connector and remove four screws securing the ADF Motor Ass'y and then remove the one screw securing the Ground Cable, as shown below. Then take out the ADF Motor Ass'y.

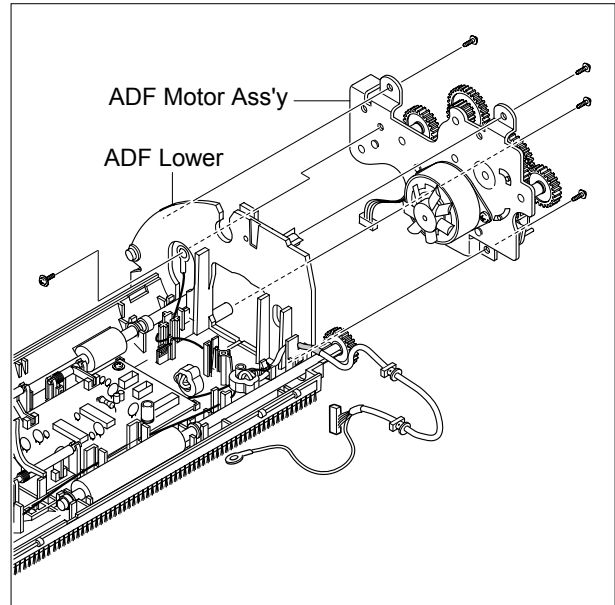

**Notice :** Before removing the ADF Engine Ass'y take great care to note the position of the Ferrite Core and the Motor Harness routing. When refitting the ADF Engine Ass'y ensure that the Harness and Ferrite are properly located and are clear of the Motor Fan and White Bar Clip.

## 5.9 OPE Unit

1. Before you remove the OPE Unit, you should remove:

- Rear Cover (Refer to 5.4)
- Side Cover (Left, Right) (Refer to 5.6)
- Scanner Ass'y (Refer to 5.7)

2. Remove the five screws securing the OPE PBA from the OPE Cover.

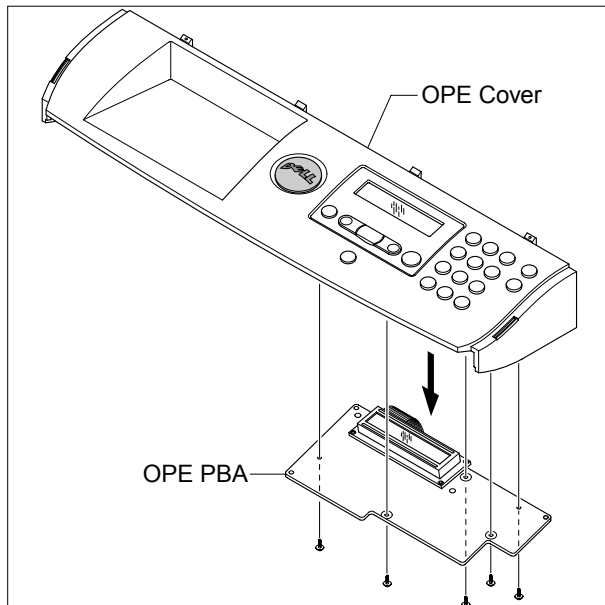

4. Remove the Keys from the OPE Cover .

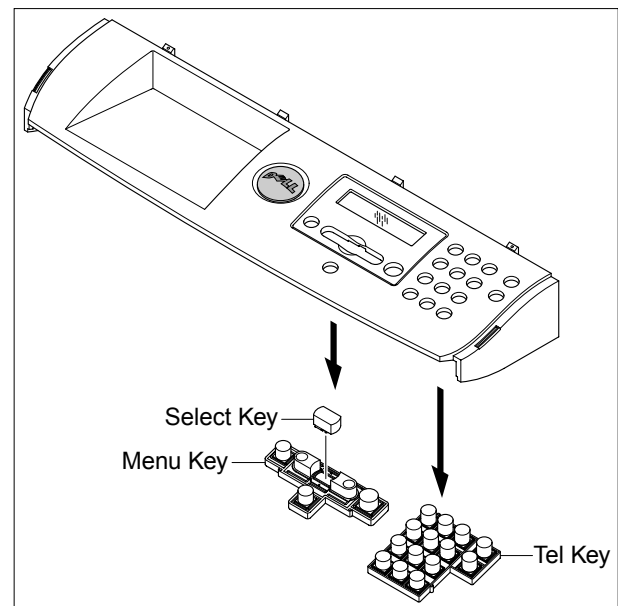

3. Remove the Contact Rubber from the OPE Cover .

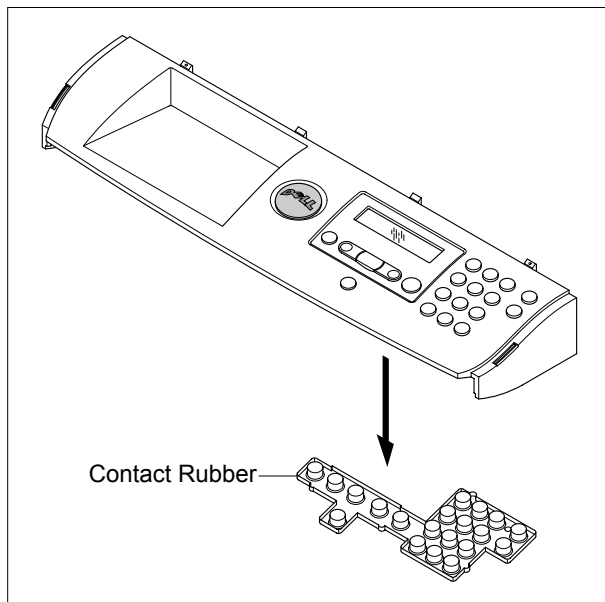

## 5.10 Shield Controller Ass'y

1. Before you remove the Shield Controller Ass'y, you should remove:
  - Rear Cover (Refer to 5.4)
  - Side Cover Left (Refer to 5.6.4)
2. Unplug the all connectors and remove the one screw securing the Ground Cable.

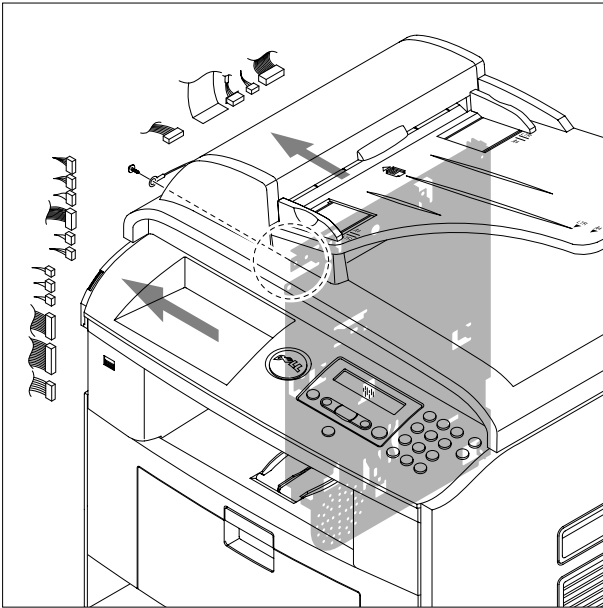

3. Remove the five screws securing the Shield Controller Ass'y and remove it.

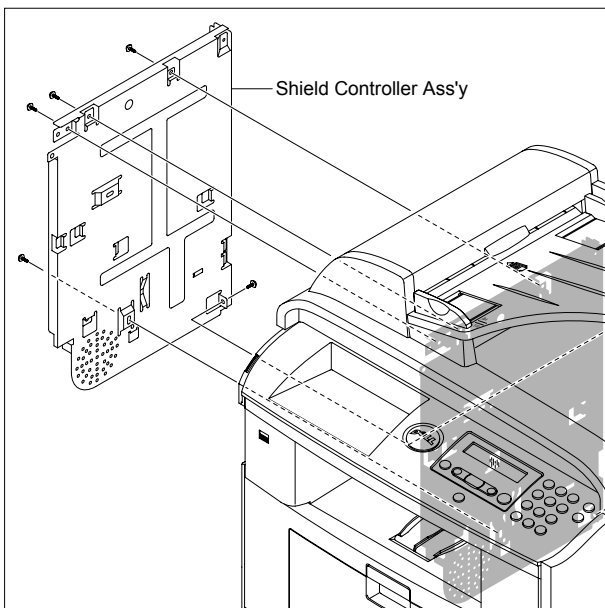

4. Remove the three screws securing the Main PBA to the Bracket and unplug the Film Cable and then remove the Main PBA.

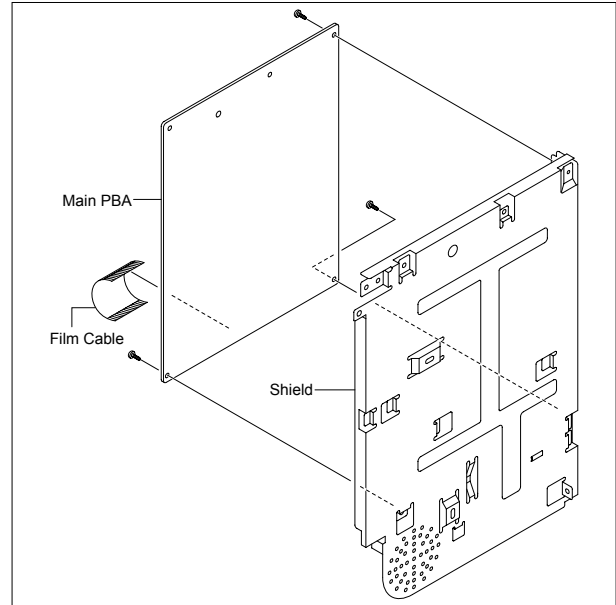

5. The connectors are located, as shown below.

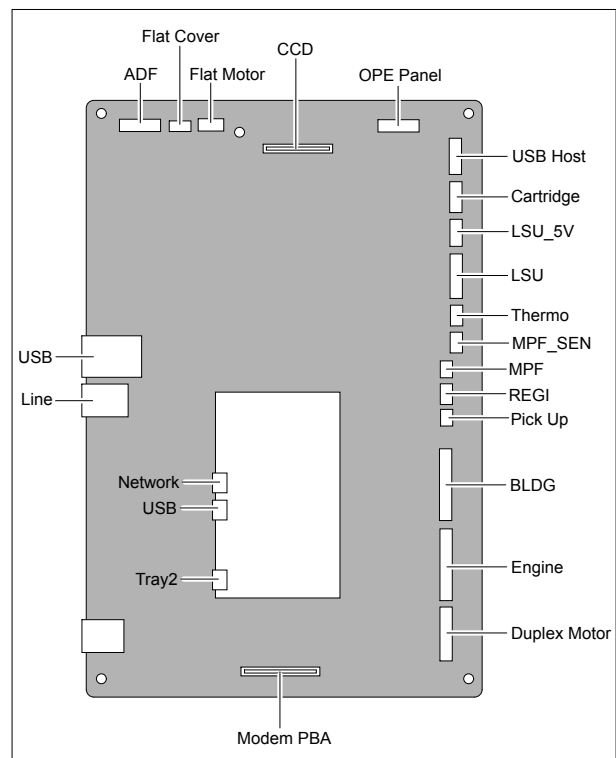

6. Remove the three screws securing the Modem PBA to the Bracket and unplug the Film Cable and then remove the Modem PBA.

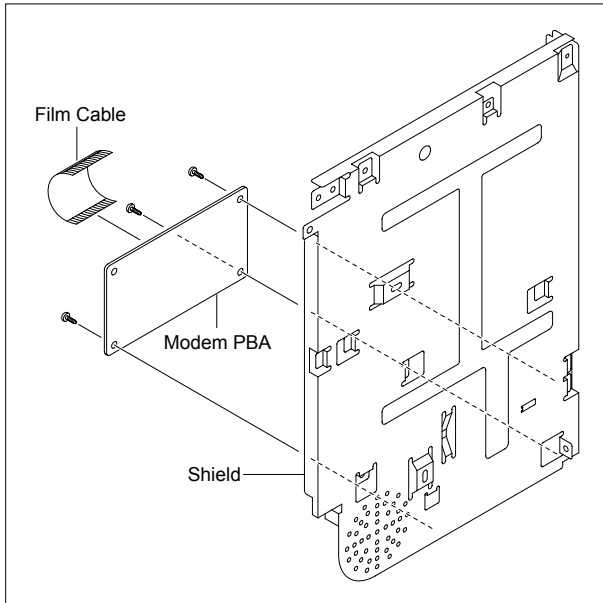

7. Remove the two screws securing the Speaker to the Bracket and unplug the connector from the Modem PBA and then remove the Speaker.

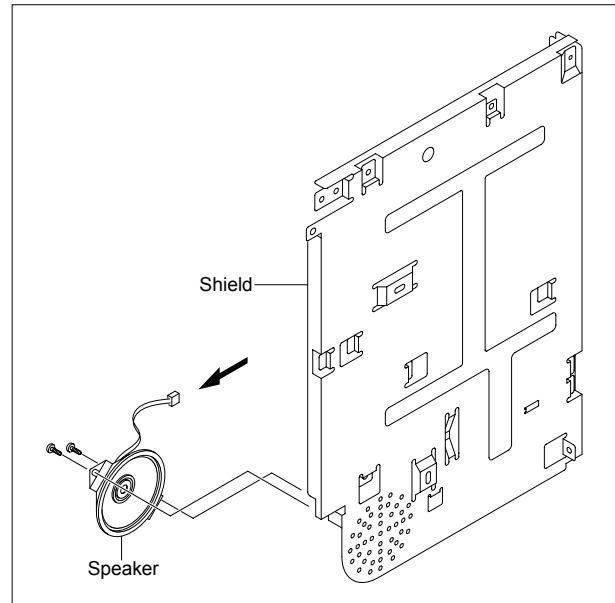

## 5.11 Drive Ass'y

1. Before you remove the Drive Ass'y, you should remove:

- Rear Cover (Refer to 5.4)
- Side Cover Left (Refer to 5.6.4)
- Shield Controller Ass'y (Refer to 5.10)

2. Remove the five screws securing the Drive Ass'y and remove it.

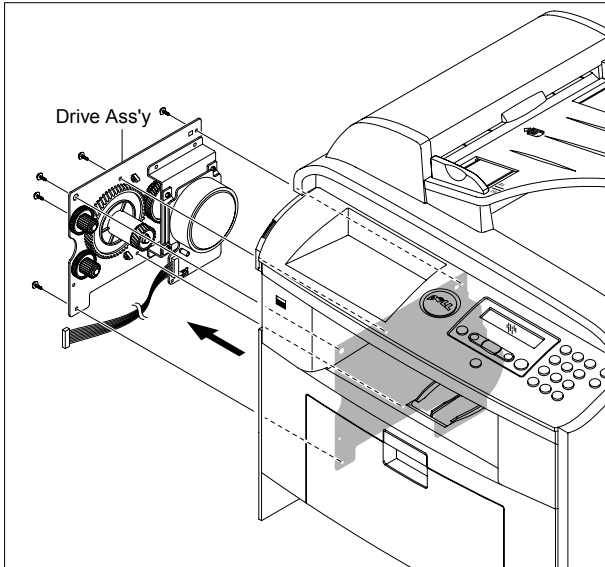

3. If necessary, remove the four screws securing the BVDC Motor Ass'y and remove it.

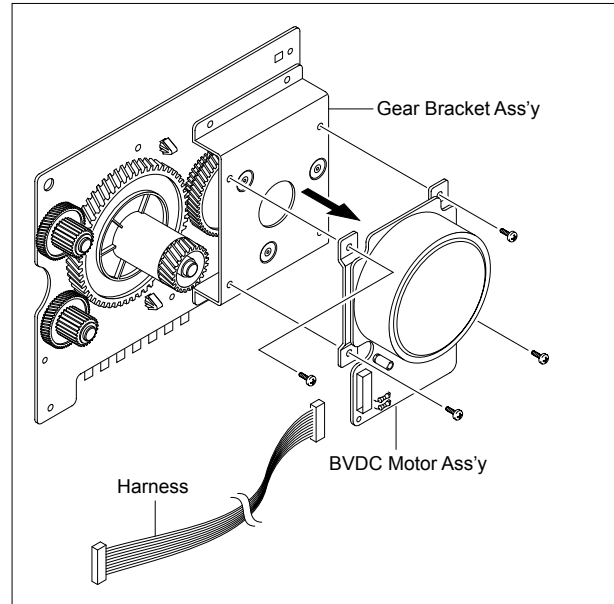

**Notice :** The six screws have numbers stamped into the Drive Ass'y base plate. When refitting the Drive Ass'y tighten the screws the order they are numbered. Only screws numbered 1 to 5 are fitted at this stage. Screw 6 is fitted when the Shield Controller Ass'y is refitted.

## 5.12 Duplex Drive Ass'y

1. Before you remove the Duplex Drive Ass'y, you should remove:
  - Rear Cover (Refer to 5.4)
  - Side Cover Right (Refer to 5.6.3)
2. Unplug the connector from the Connection PCB and remove the three screws securing the Duplex Drive Unit and remove it.

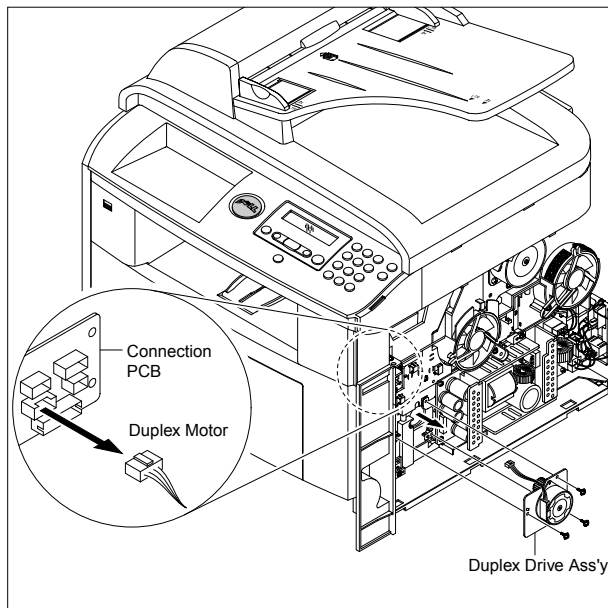

3. If necessary, remove the two screws securing the Duplex Motor and remove it.

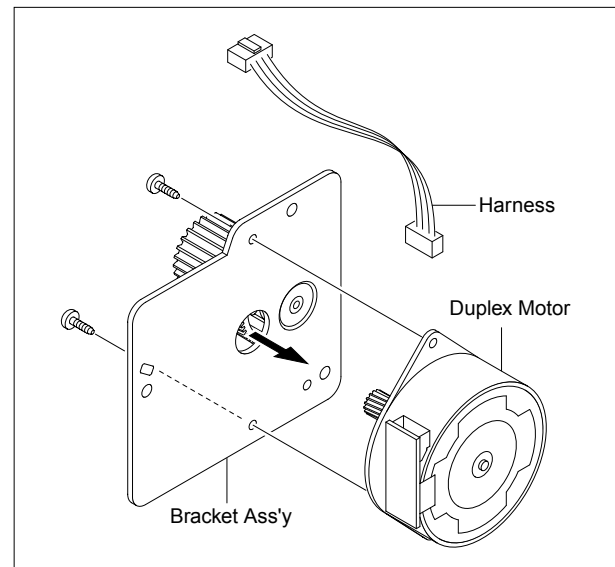



## 5.13 Shield SMPS Ass'y

1. Before you remove the Shield SMPS Ass'y, you should remove:

- Rear Cover (Refer to 5.4)
- Side Cover Right (Refer to 5.6.3)
- Duplex Drive Ass'y (Refer to 5.12)

2. Unplug the two connectors (HVPS, Fuser).

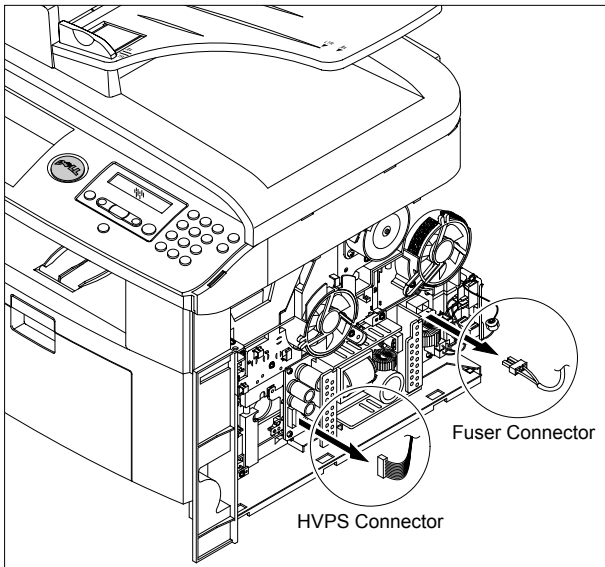

3. Remove the three screws securing the Shield SMPS Ass'y and remove it.

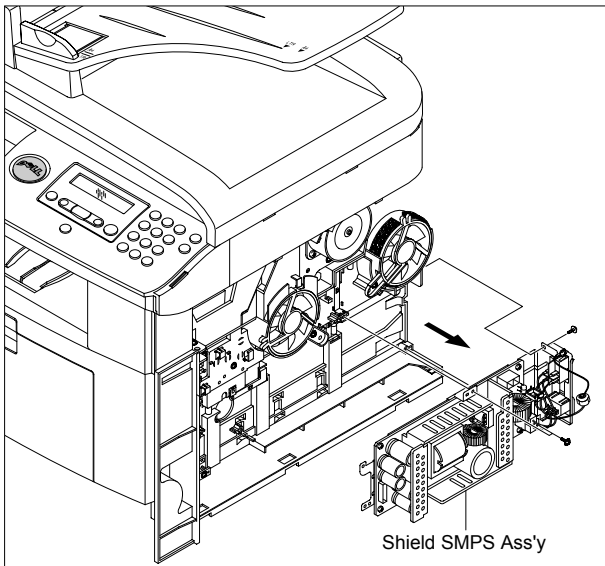

4. Unplug the connector (AC Inlet) and remove the four screws securing SMPS and remove it.

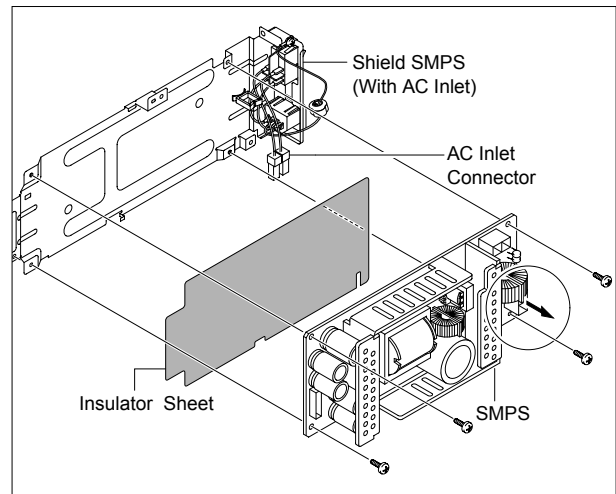

## 5.14 Connection PCB

1. Before you remove the Connection PCB, you should remove:

- Rear Cover (Refer to 5.4)
- Side Cover Right (Refer to 5.6.3)

2. Unplug the all connectors.

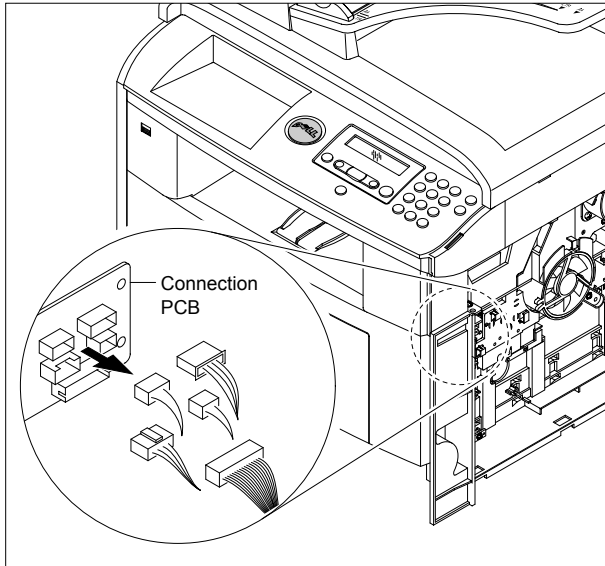

3. Remove the two screws securing the Connection PCB and remove it.

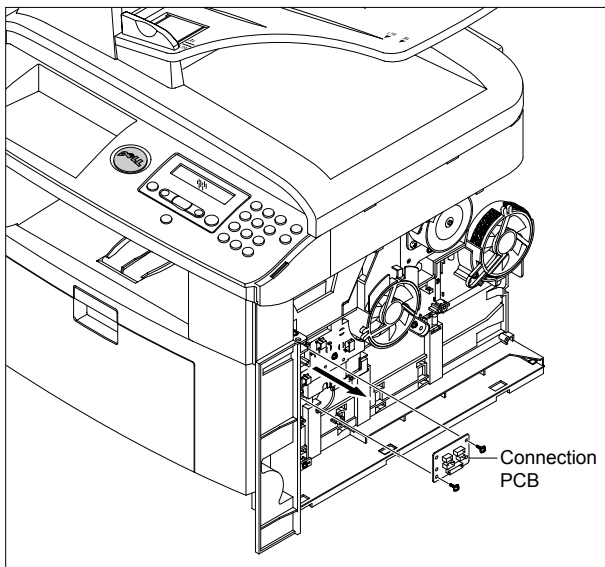

4. The connectors are located, as shown below.

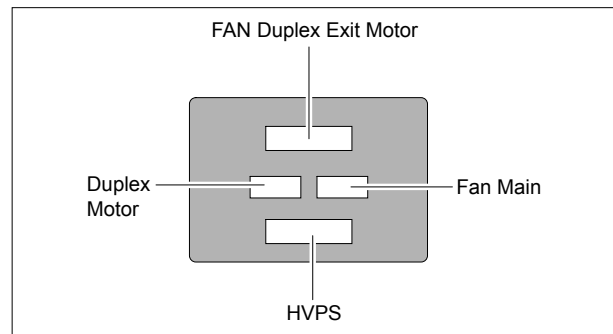

## 5.15 Fuser Drive Ass'y

1. Before you remove the Fuser Drive Ass'y, you should remove:

- Rear Cover (Refer to 5.4)
- Side Cover Right (Refer to 5.6.3)

2. Unplug the connector from the Connection PCB.

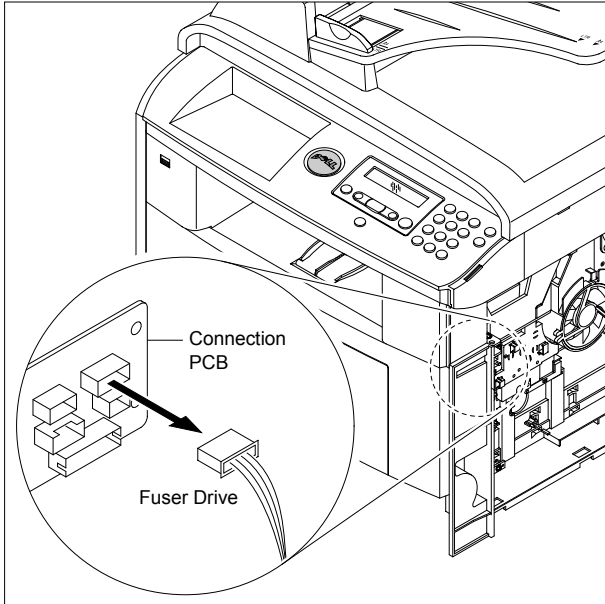

4. If necessary, remove the two screws securing the Step Motor and remove it.

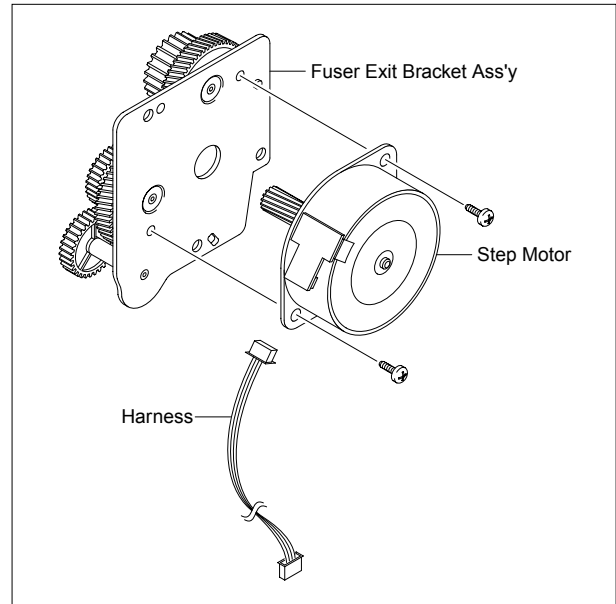

3. Remove the three screws securing the Fuser Drive Ass'y and remove it.

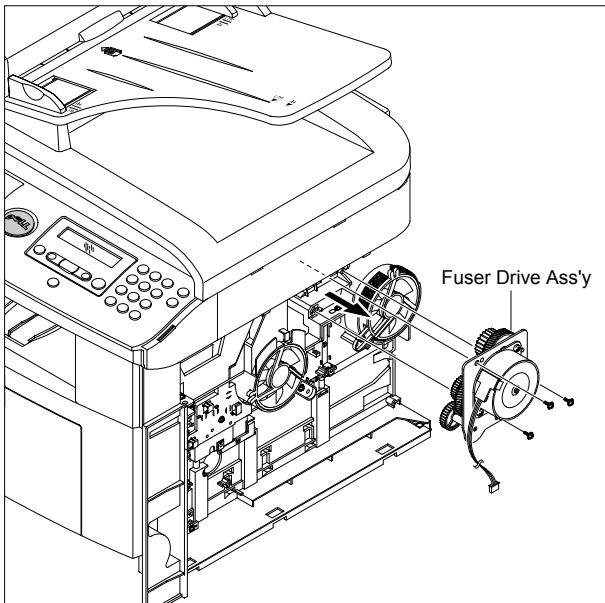

## 5.16 Fan

1. Before you remove the Fan, you should remove:
  - Rear Cover (Refer to 5.4)
  - Side Cover Right (Refer to 5.6.3)
2. Unplug the two connectors from the Connection PCB, as shown below.

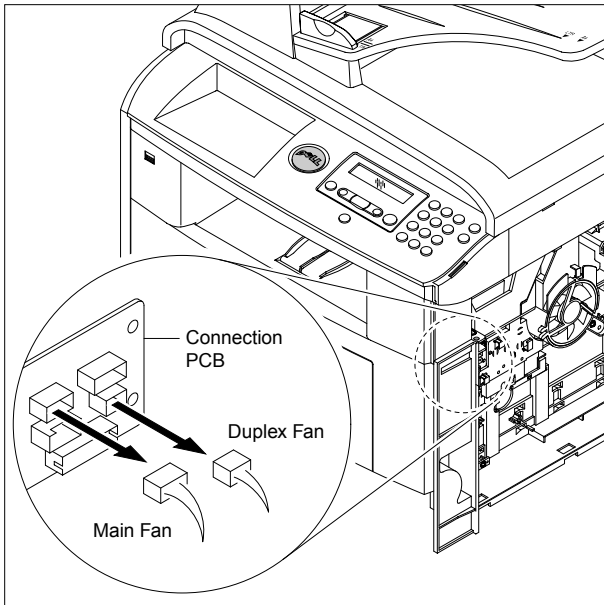

3. Remove the two screws securing the Fans and then pull the Fans (Main, Duplex).

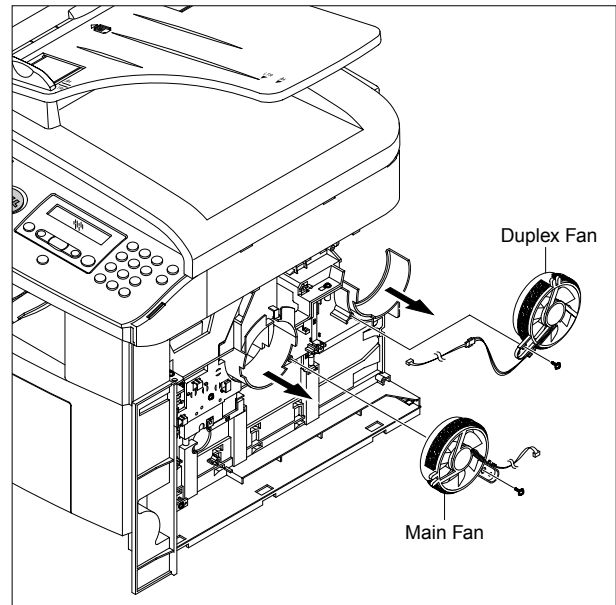

## 5.17 Pick Up Roller Ass'y

1. Take out the Cassette.

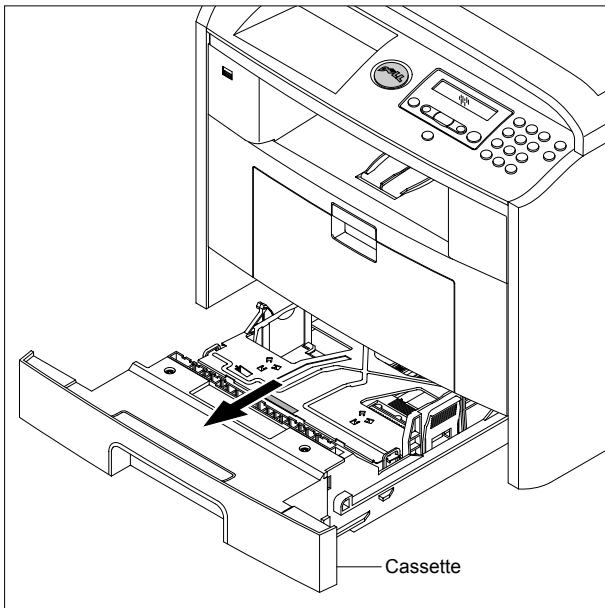

2. To remove the Pick Up Roller Ass'y, first lift the notch attached to the Pick Up Roller Ass'y from the Shaft, then slide the Pick Up Roller Ass'y from left to right and it will be released completely, as shown below.

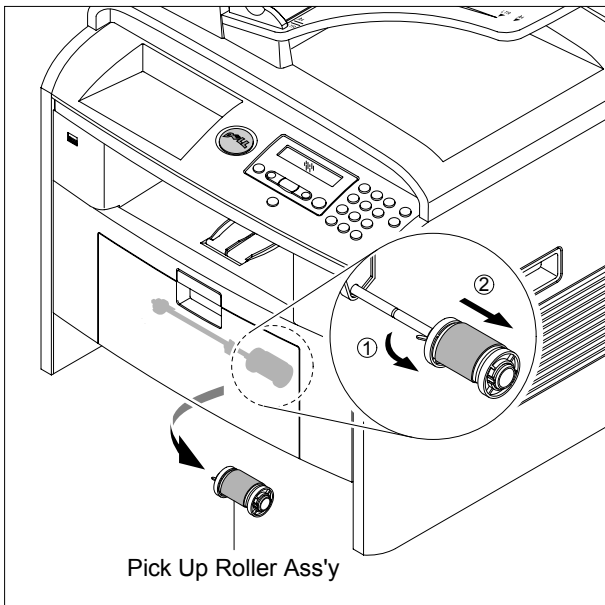

3. To remove the Shaft, first release the locker and slide the Shaft from left to right, then lift the notch attached to the Cam so that it's released from the Shaft. Then release the Bush from the Shaft and remove the Shaft from the Duplex Guide Housing, as shown below.

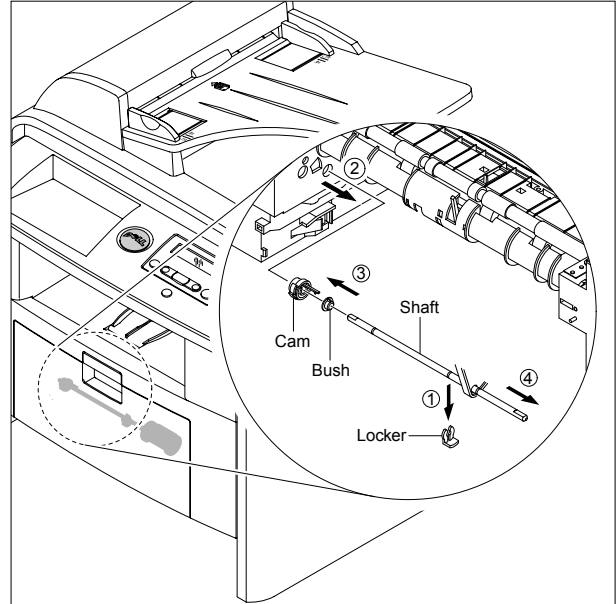

## 5.18 Duplex Guide Housing (With Feed Roller)

1. Before you remove the Duplex Guide Housing, you should remove:
  - Pick Up Roller Ass'y (Refer to 5.17)
2. Remove the two screws securing the Duplex Guide Housing.

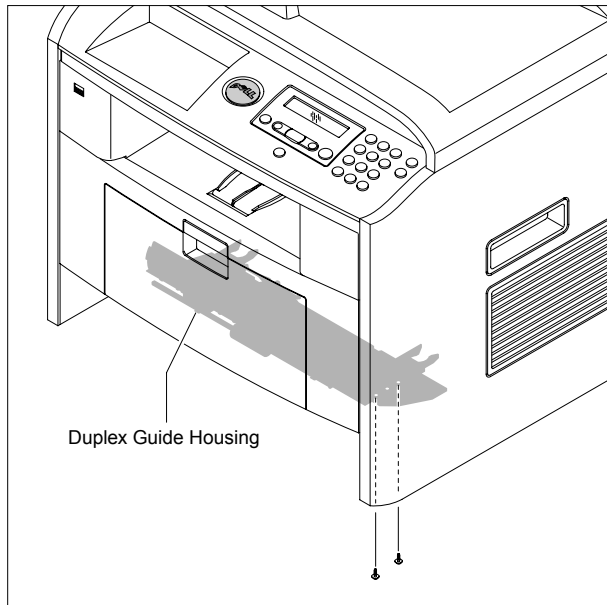

4. Pull the Feed Roller from the Bushing.

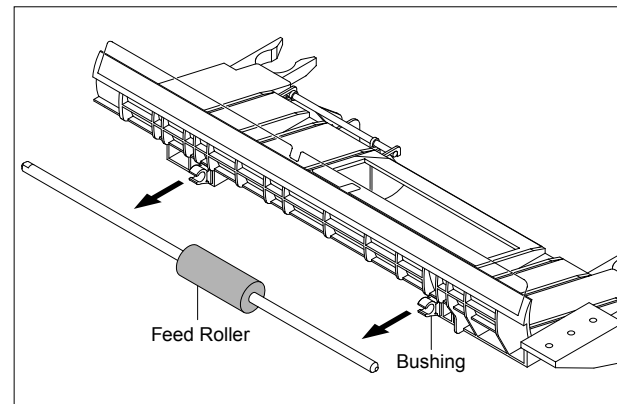

3. Unplug the one connector (Photo Interrupter) and remove the Duplex Guide Housing (with Feed Roller), as shown below.

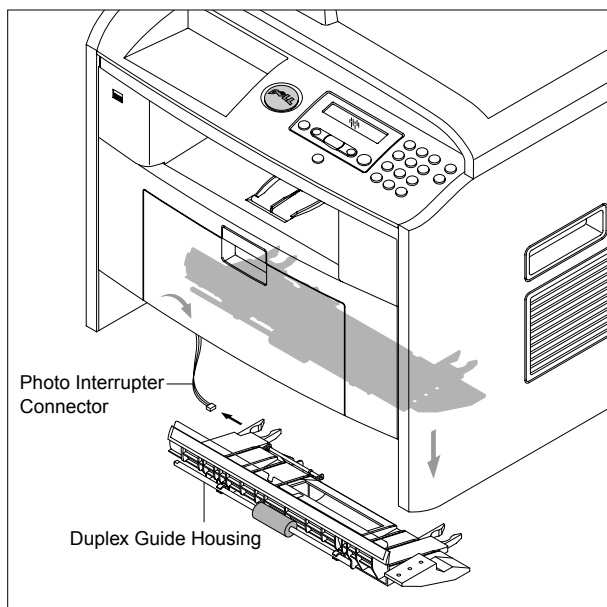

## 5.19 HVPS Housing

1. Before you remove the HVPS Housing, you should remove:

- Duplex Drive Ass'y (Refer to 5.12)
- Pick Up Roller Ass'y (Refer to 5.17)
- Duplex Guide Housing (Refer to 5.18)
- Unplug the two Connectors (HVPS) (p5-22)

2. Remove the eight screws securing the HVPS Housing, as shown below.

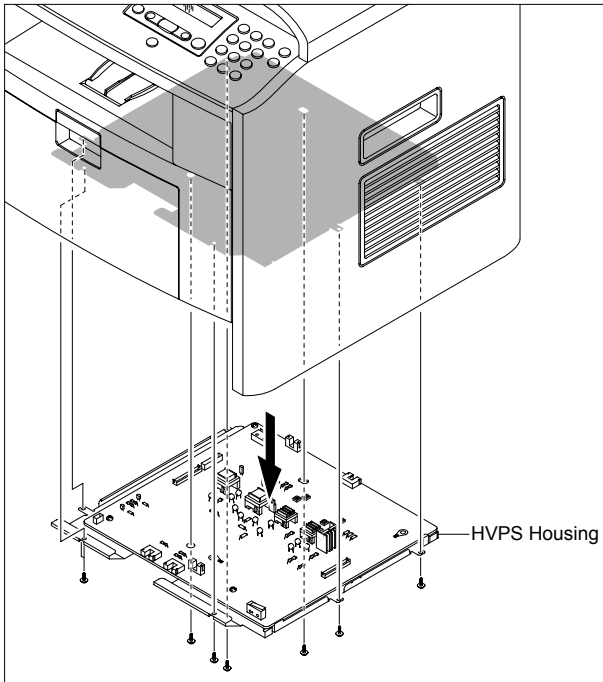

4. If necessary, remove the three screws securing the HVPS and remove it.

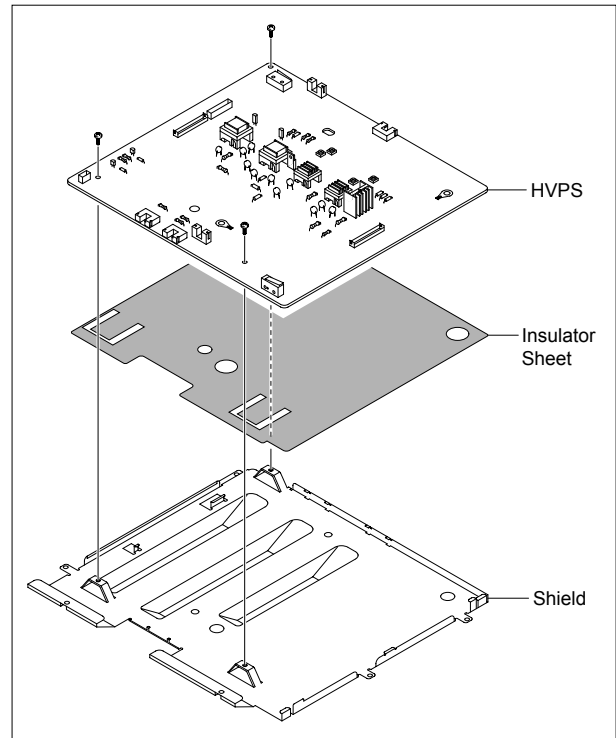

3. Unplug the connector for connection PBA & SMPS first. Unplug the other connectors.

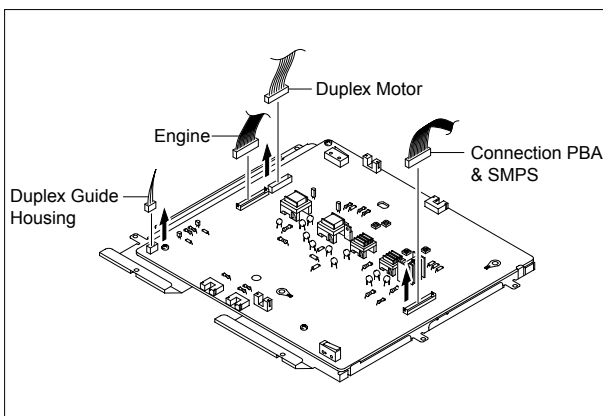

## 5.20 Middle Cover Ass'y

- Before you remove the Middle Cover Ass'y, you should remove:
  - Rear Cover (Refer to 5.4)
  - Side Cover (Left, Right) (Refer to 5.6)
  - Scanner Ass'y (Refer to 5.7)
  - Shield Controller Ass'y (Refer to 5.10)
- Remove the six screws securing the Middle Cover Ass'y and remove it.

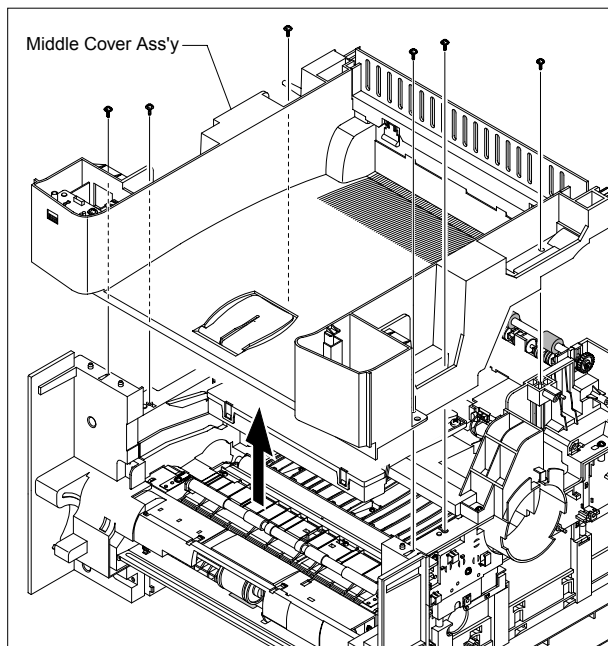

- If necessary, remove the two screws securing the USB Host PBA and remove it.

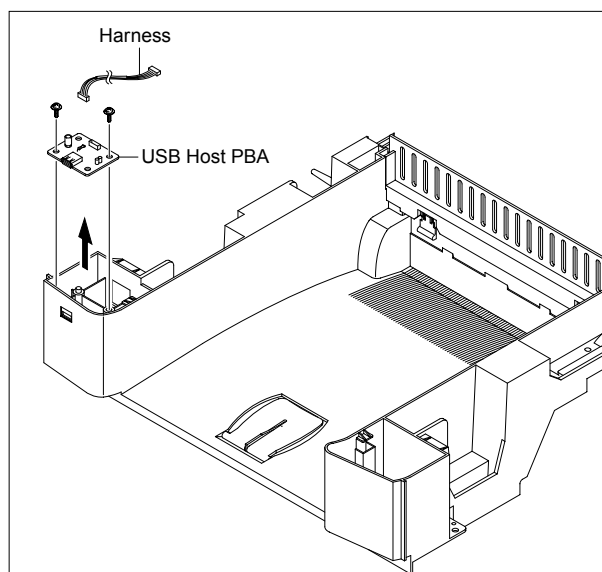

## 5.21 Cover Mid Front

- Before you remove the Cover Mid Front, you should remove:
  - Middle Cover Ass'y (Refer to 5.20)
- Remove the four screws securing the Cover Mid Front and release two hooks in the center. This cover is fragile take care when removing it.

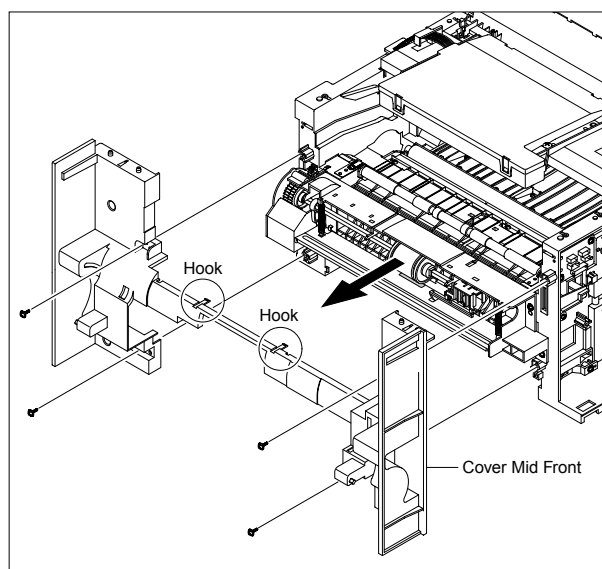



## 5.22 MPF Housing

1. Before you remove the MPF Housing, you should remove:
  - Cover Mid Front (Refer to 5.21)
2. Remove the four screws securing the MPF Housing and remove it.

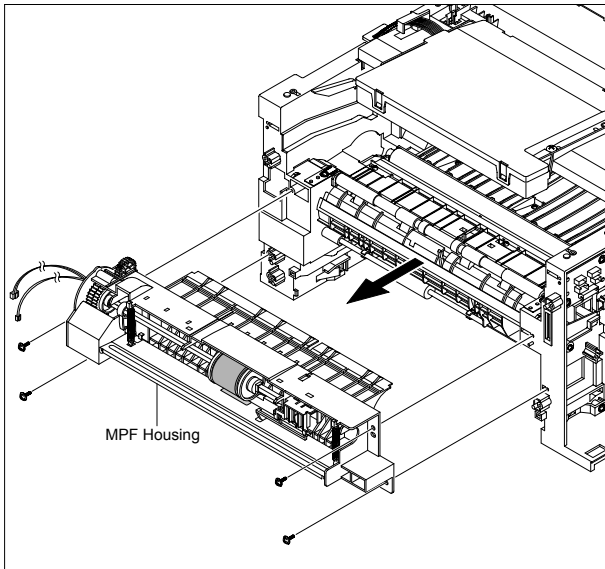

3. To remove the MP Pick Up Ass'y, first lift the notch attached to the left side Stopper so that it's slide the right to left from the Shaft, then left side Idle slid the right to left from the Shaft and take out the MP Pick Up Ass'y, as shown below.

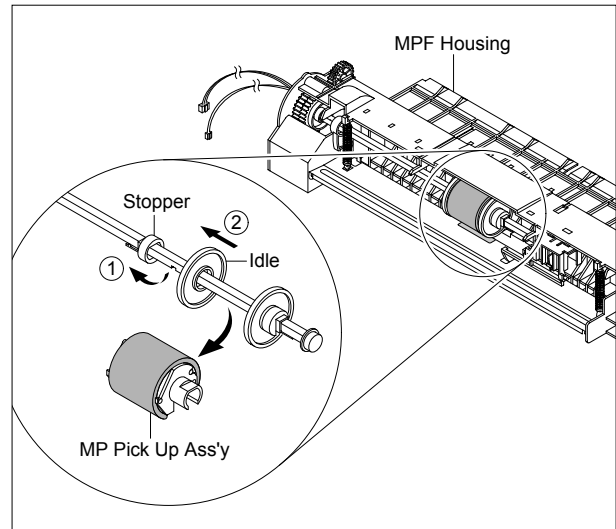

## 5.23 Feed Roller Parts

1. Before you remove the Feed Roller Parts, you should remove:

- Pick Up Roller Ass'y (Refer to 5.17)
- Duplex Guide Housing (Refer to 5.18)
- Middle Cover Ass'y (Refer to 5.20)
- MPF Housing (Refer to 5.22)

2. Remove the two screws securing the both side of the Guide Paper and then remove the Guides.

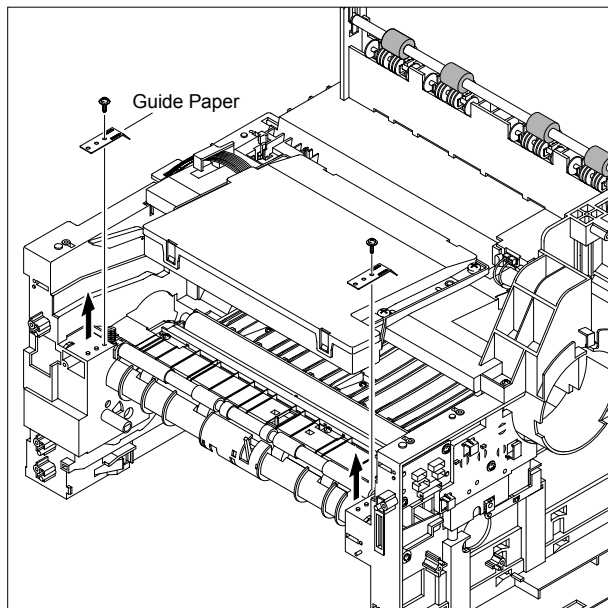

3. Pull up the Feed Idle Shaft and the Bushs (with Spring).

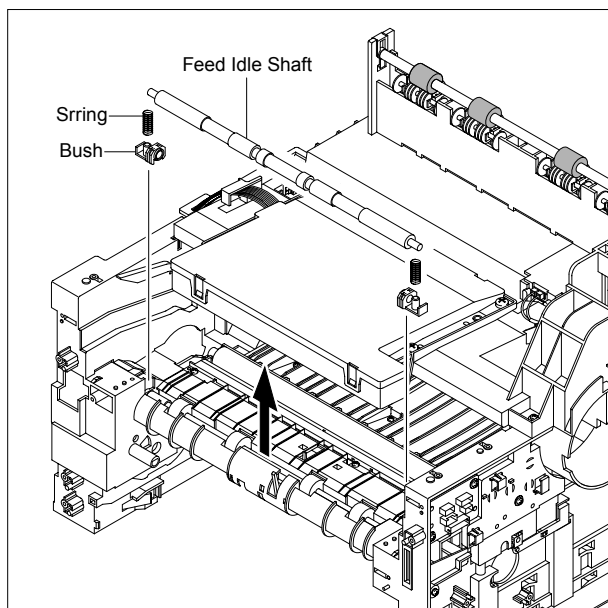

4. Release the E-Ring securing the Feed2 Gear and remove it.

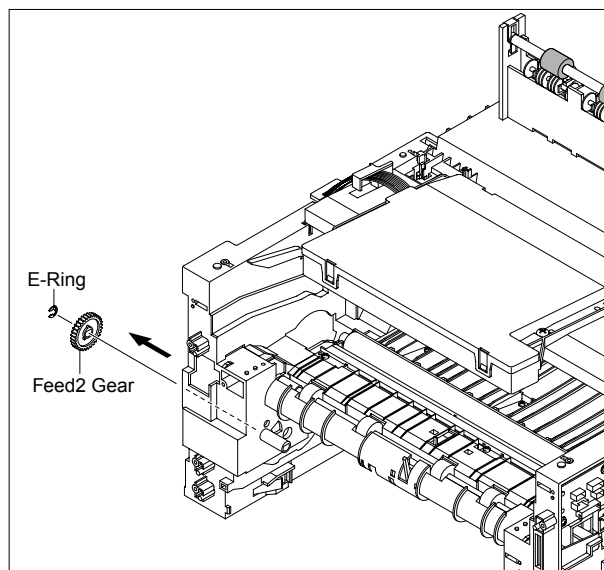

5. Remove the three screws securing the Feed Bracket Unit and then remove the Feed Bracket Unit and Feed2 Shaft.

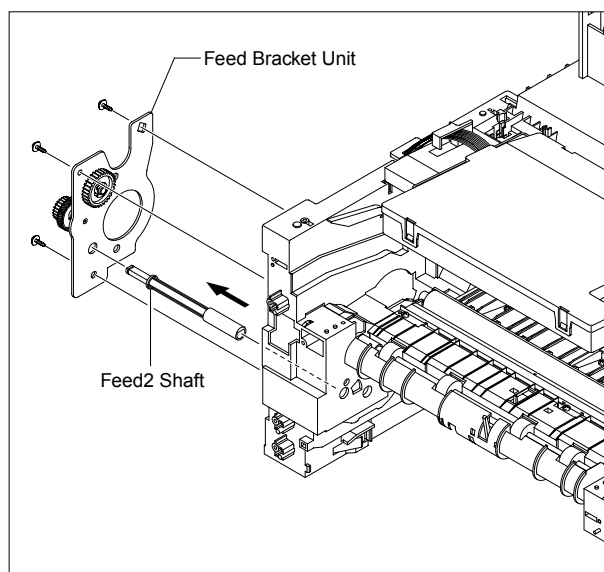

6. If necessary, release the three E-Rings securing the Gears (T2 Idle, Retard, Idle) and then remove the Gears from the Feed Bracket, as shown below.

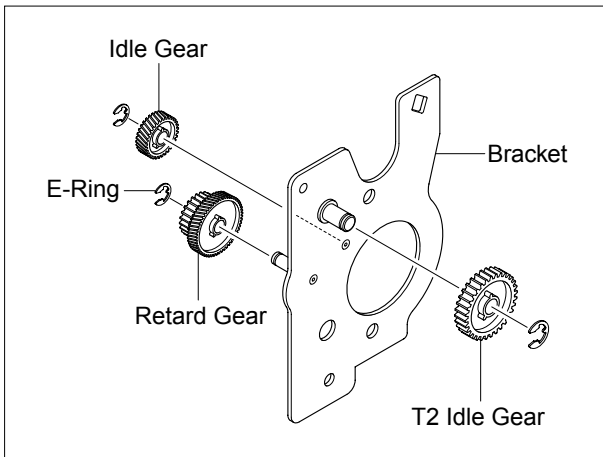

**Notice :** Be aware of the E-Rings to ensure they are not lost.

7. Remove the Clutch Unit, as shown below.

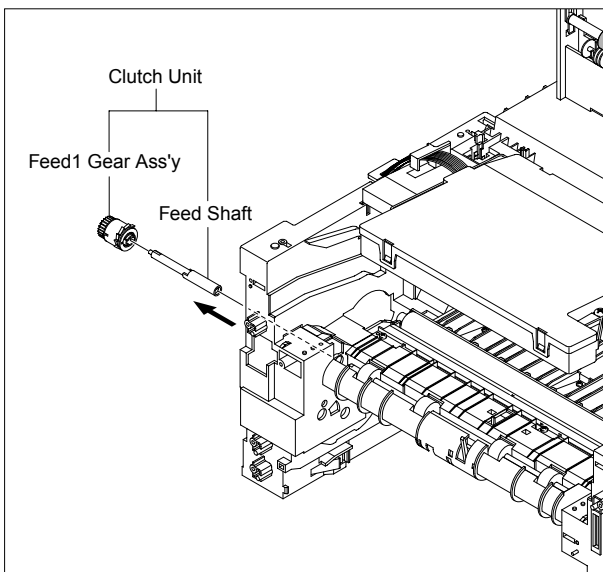

8. Pull up the Feed1 Roller from the Bushing, as shown below.

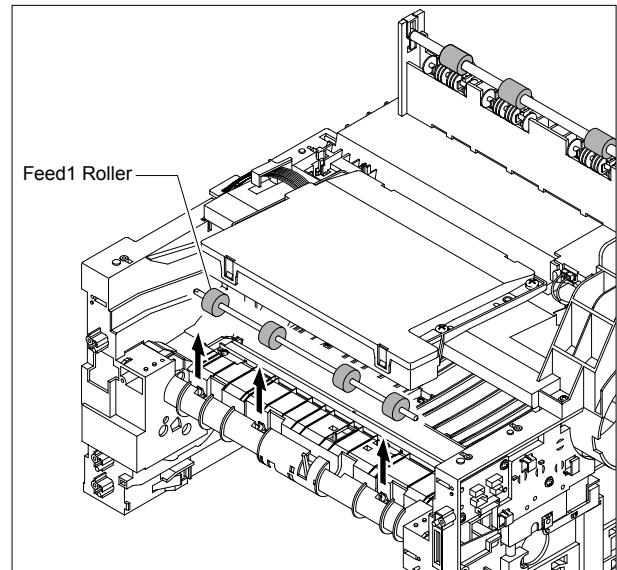

## 5.24 Pick Up Gear Ass'y & Solenoids

- Before you remove the Pick Up Gear Ass'y & Solenoids, you should remove:
  - Duplex Guide Housing (Refer to 5.18)
  - Feed Bracket Unit (Refer to 5.23.5)
- Release the Pick Up Gear Ass'y and Pick Up Gear Shaft, as shown below.

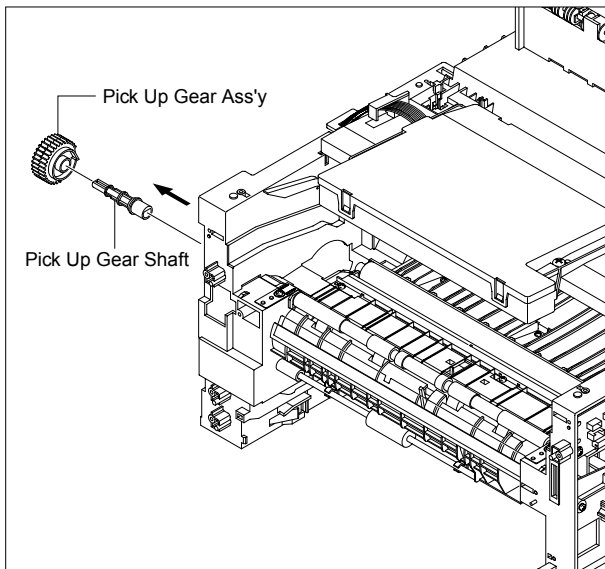

- Remove the two screws securing the Manual Solenoid and Feed Solenoid and then remove the Solenoids, as shown below.

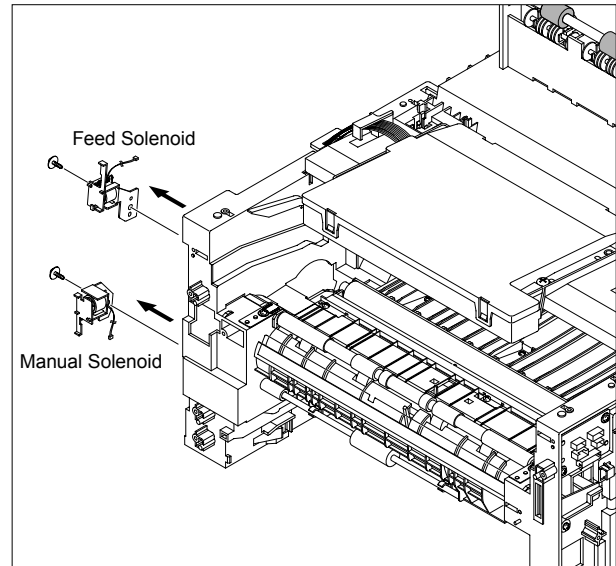

## 5.25 Exit Roller

- Before you remove the Exit Roller, you should remove:
  - Fuser Drive Ass'y (Refer to 5.15)
  - Middle Cover Ass'y (Refer to 5.20)
- Remove the Exit Gear, and release the Bearing at one end then remove the Roller Exit F/Down and Exit Roller Rack, as shown below.

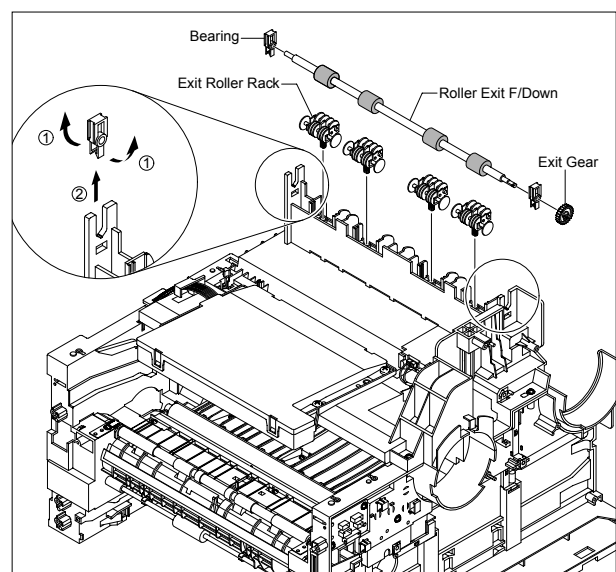

## 5.26 LSU

1. Before you remove the LSU, you should remove:
  - Middle Cover Ass'y (Refer to 5.20)

2. Remove the four screws securing the LSU and remove it.

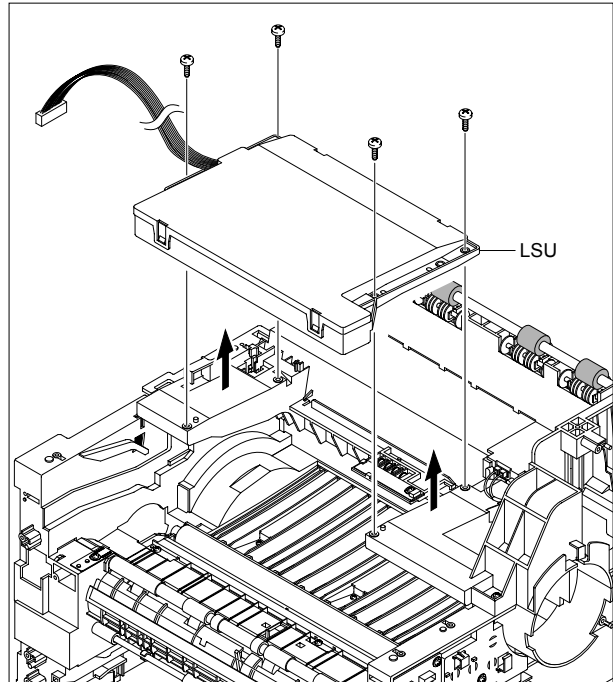

## 5.27 Terminal PBA

1. Before you remove the CRUM2 PBA, you should remove:
  - Middle Cover Ass'y (Refer to 5.20)
  - LSU (Refer to 5.26)

2. Remove the one screw securing the CRUM2 PBA and remove it and then release the four Terminals, as shown below.

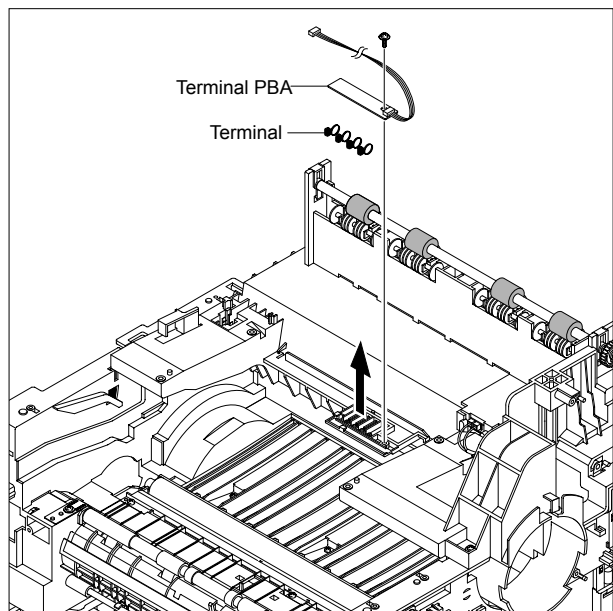

**Notice :** Be aware of the Terminals to ensure they are not lost.

## 5.28 Transfer Roller Parts

1. To remove the Transfer Roller, first push the TR Holder and then take out the Transfer Roller, as shown below.

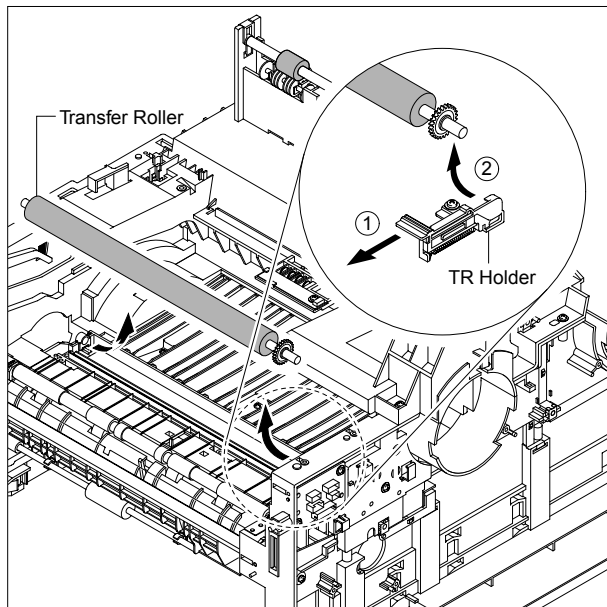

**Notice :** Do not grab the rubber part of the Transfer Roller, it may cause a malfunction due to a foreign object. Hold the both side of the Transfer Roller when replacing it.

## 6. Alignment and Adjustments

This chapter describes the main functions for service, such as the product maintenance method, the test output related to maintenance and repair, DCU using method, Jam removing method, and so on. It includes the contents of manual.

### 6.1 Paper path

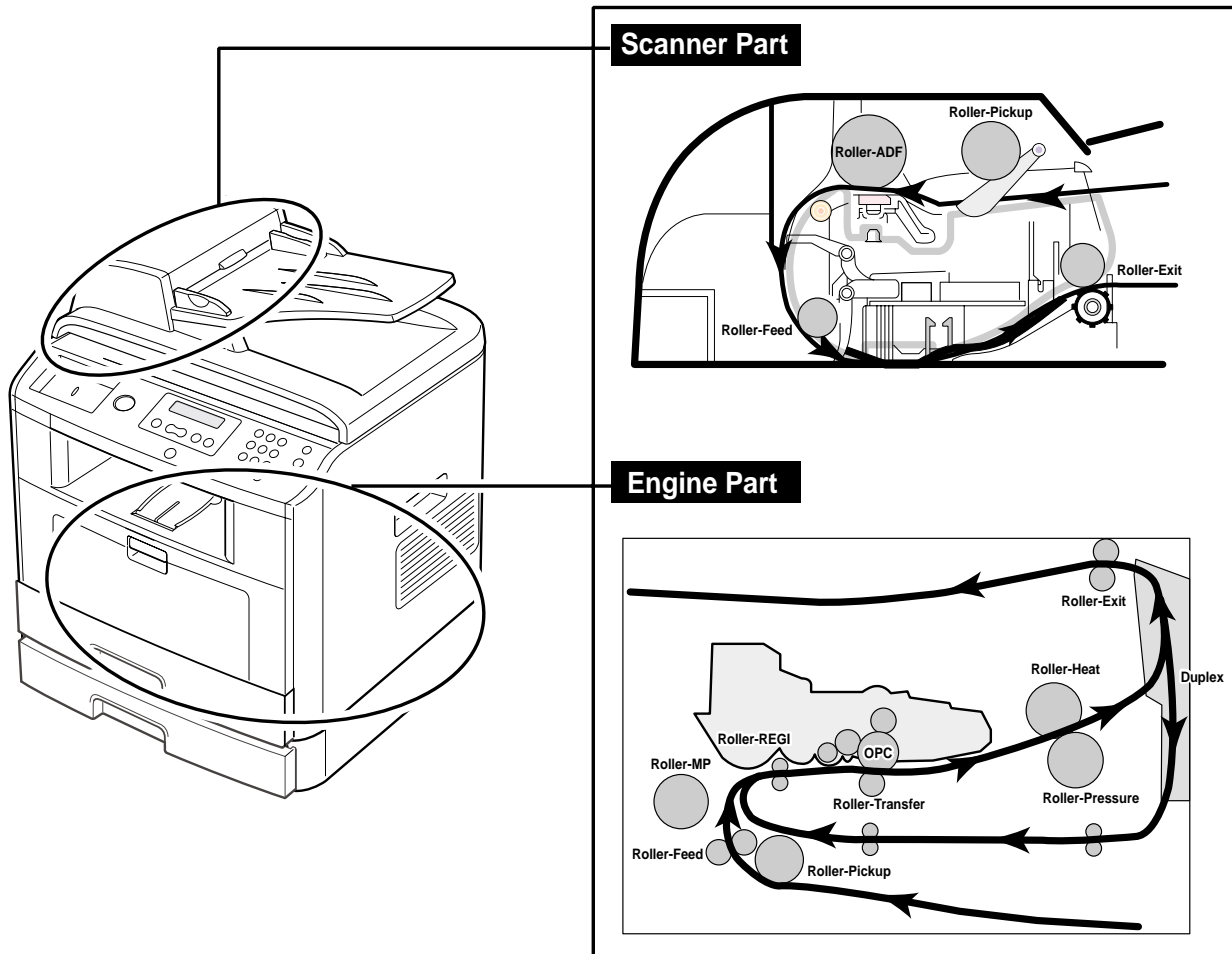

## 6.2 Clearing Paper Jams

---

Occasionally, paper can be jammed during a print job. Some of the causes include:

- The tray is loaded improperly or overfilled.
- The tray has been pulled out during a print job.
- The front cover has been opened during a print job.
- Paper was used that does not meet paper specifications.
- Paper that is outside of the supported size range was used.

If a paper jam occurs, LCD window will show it's speeds. Find and remove the jammed paper. If you don't see the paper, open the covers.

Do not use a pinset or a sharp metal tool when removing a jam.

The covering of a metal part can be removed which can cause an electric leakage.



## 6.2.1 Clearing Document Jams

When a document jams while it passes through the ADF, Document Jam appears on the display.

**NOTE:** To prevent document jams, use the document glass for thick, thin or mixed documents.

1. Remove the remaining documents from the ADF.

If the document is jammed in the paper feed area:

a. Open the ADF cover.

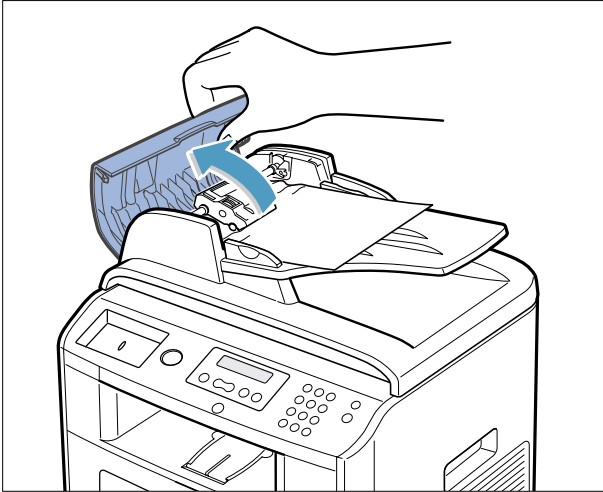

c. Close the ADF cover. Then reload the document into the ADF.

b. Remove the document by gently pulling it out.

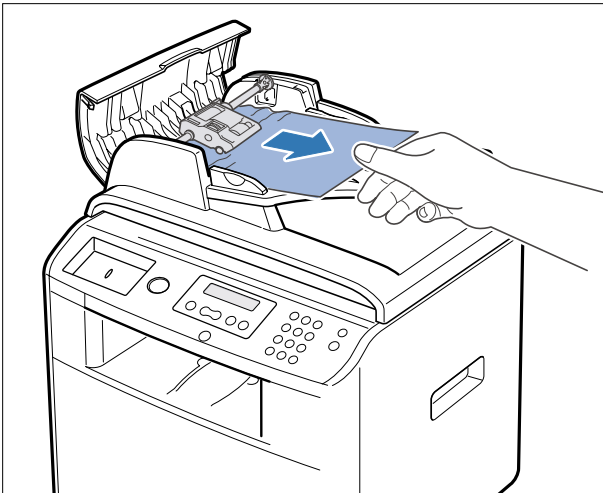

If the document is jammed in the paper exit area:

- a. Open the document cover and turn the release knob to remove the misfed documents from the document document output tray.

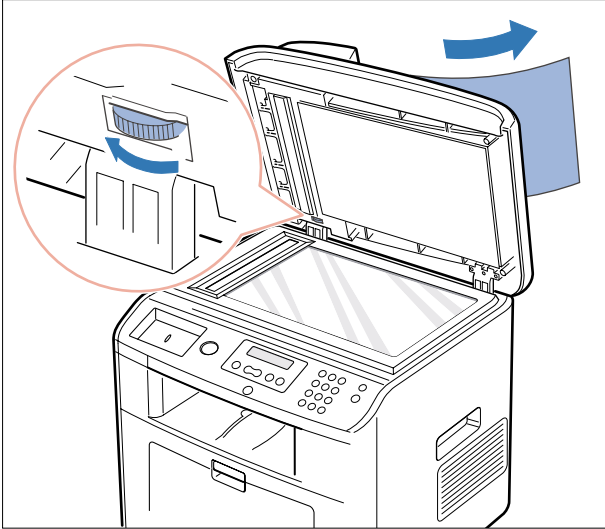

- b. Close the document cover. Then load the documents back into the ADF.

2. If you cannot see the paper or the paper does not move when you pulled, open the document cover.
3. Turn the release knob so that you can easily seize the misfed document, and remove the document from the roller or the feed area by carefully pulling it gently to the right.

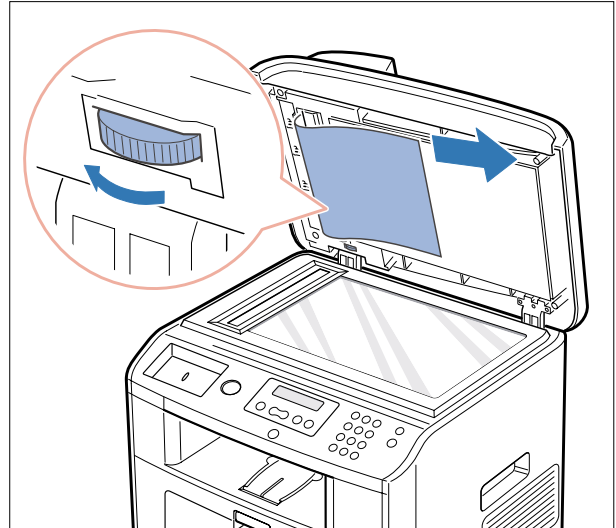

4. Close the document cover. Then load the documents back into the ADF.

## 6.2.2 Clearing Jams in the Paper Paths

When a paper jam occurs, Paper Jam appears on the display . Refer to the table below to locate and clear the paper jam.

Operator Panel Message	Location of Jam	Go to
Paper Jam 0 Open Front Door	Paper Feed Jam (tray 1) Paper Feed Jam (optional tray 2)	"Paper Feed Jam (tray 1)" or "Paper Feed Jam (optional tray 2)".
Paper Jam 1 Cartridge Area	Fuser Area Jam	"Fuser Area Jam".
Paper Jam 2 Open Rear Door	Paper Exit Jam	"Paper Exit Jam".
Duplex Jam 0 Check Inside a	in the duplex unit	"Duplex Jam 0".
Duplex Jam 1 Check Inside a	between the duplex unit and fuser area	"Duplex Jam 1".

To avoid tearing the paper, pull the jammed paper out gently and slowly . Follow the steps below to clear the jam.

### 6.2.3 Paper Feed Jam (tray 1)

1. Open and close the front cover. The jammed paper automatically exits the printer. If the paper does not exit, go to the next step.
2. Pull the paper tray open.

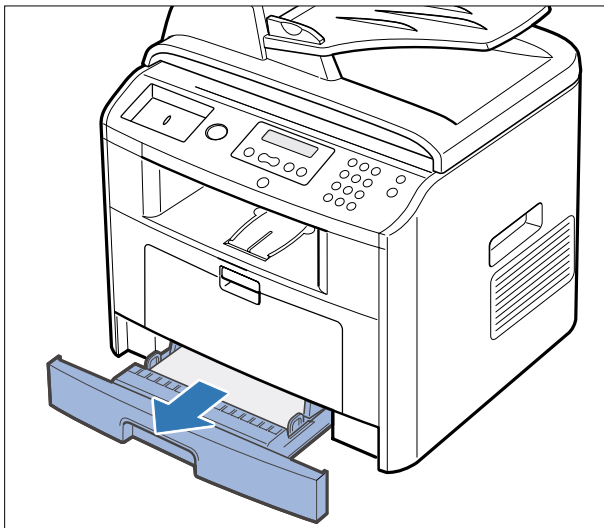

3. Remove the paper by gently pulling it straight out.

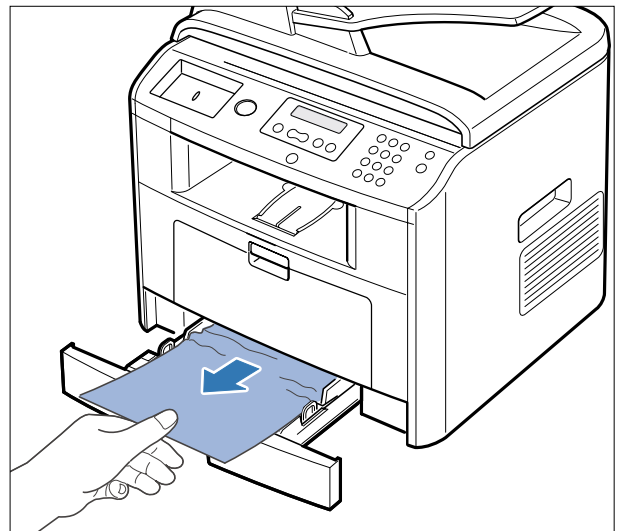

If you cannot see the paper or the paper does not move when pulled, check the fuser area. For more information, see "Fuser Area Jam".

4. Insert the paper tray into the printer until it snaps into place.  
Printing automatically resumes.

### 6.2.4 Paper Feed Jam (optional tray 2)

1. Pull the optional tray 2 open.
2. Remove the jammed paper from the printer.
3. Pull the tray 1 half.
4. Pull the paper straight up and out.

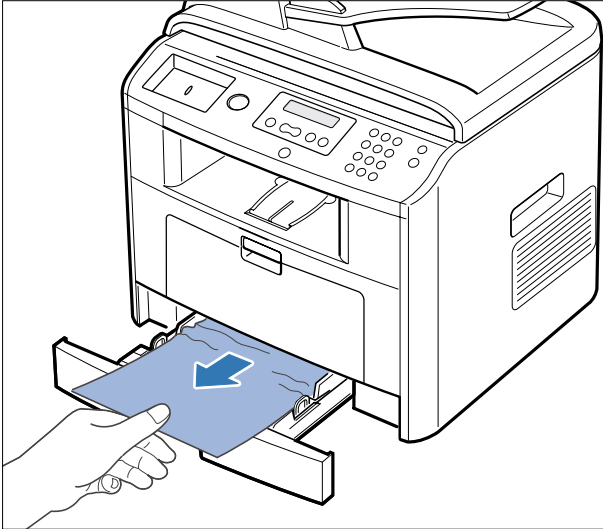

If you cannot see the paper in this area or the paper does not move when pulled, go to the next step.

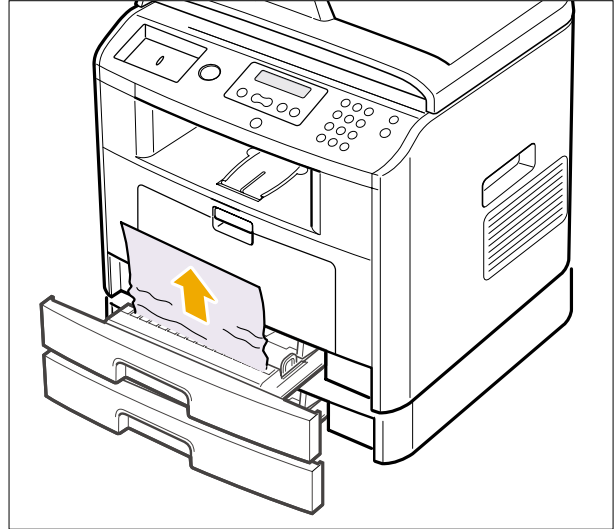

### 6.2.5 Bypass tray Jam

1. If the paper is not feeding properly, pull the paper out of the printer.
2. Open and close the front cover to resume printing.

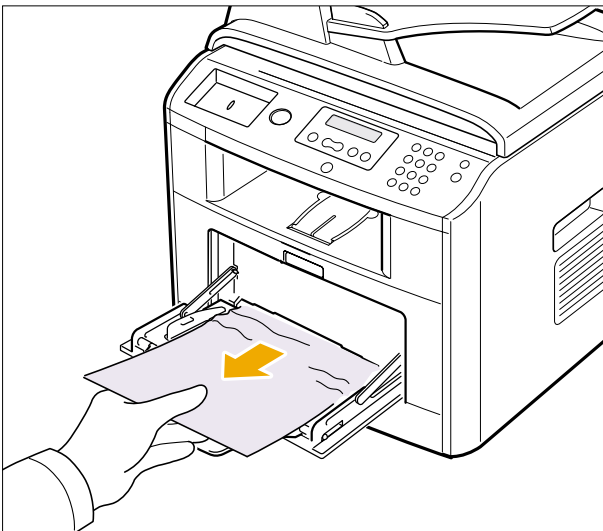

## 6.2.6 Fuser Area Jam

**NOTICE:** The fuser area is hot. Take care when removing paper from the printer.

1. Open the front cover and lightly pull the toner cartridge straight out.

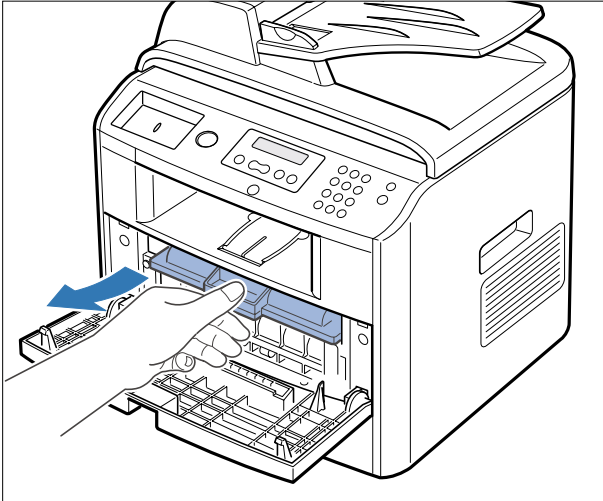

2. Remove the paper by gently pulling it straight out.

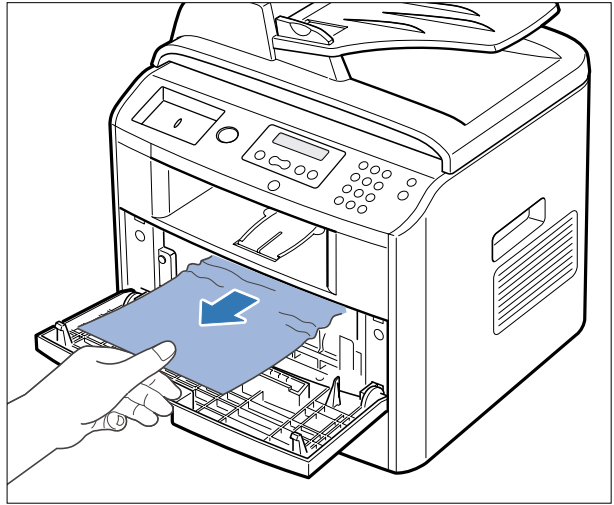

3. Replace the toner cartridge and close the front cover. Printing automatically resumes.

## 6.2.7 Paper Exit Jam

1. Open and close the front cover. The jammed paper automatically exits the printer. If the paper does not exit, go to the next step.

2. Gently pull the paper out of the output tray.

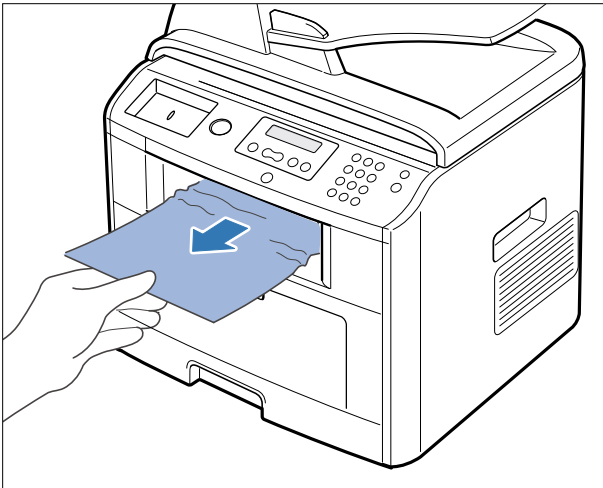

3. If you cannot see the paper in the output tray or the paper does not move when pulled, open the rear cover.

4. If you see the jammed paper, push the two blue pressure levers up and remove the paper.

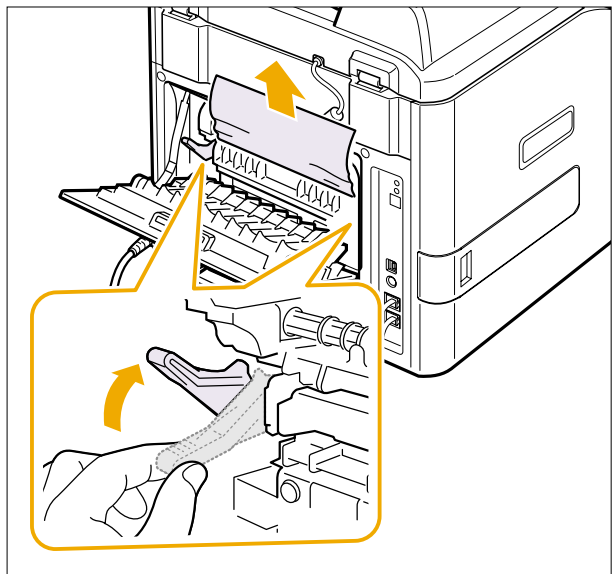

If you do not see the paper, go to the next step.

5. Release the blue strap, the rear cover stopper, and fully open the rear cover, as shown.

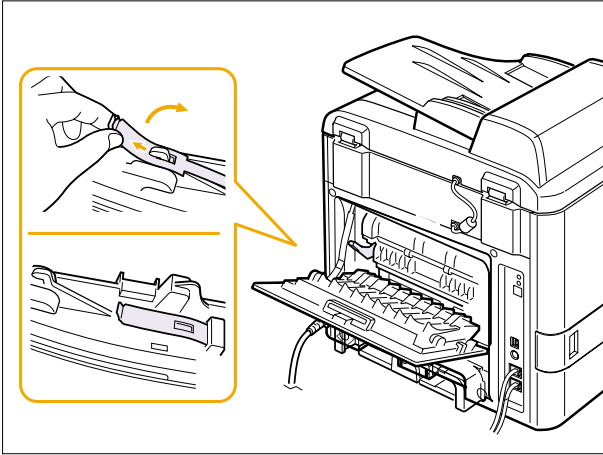

6. Unfold the duplex guide fully.

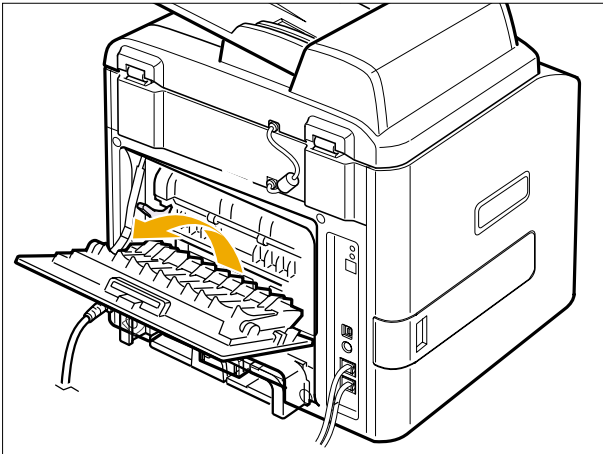

7. While pushing the fuser lever to the right, open the fuser door.

**NOTE:** Make sure to unfold the fuser guide before opening the fuser door or you may damage the fuser door.

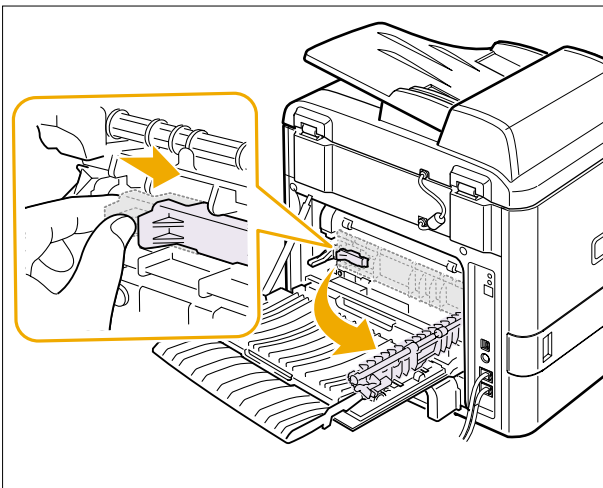

8. Pull the jammed paper out. If the jammed paper does not move when you pull, push the two blue pressure levers up to loosen the paper, and then remove it.

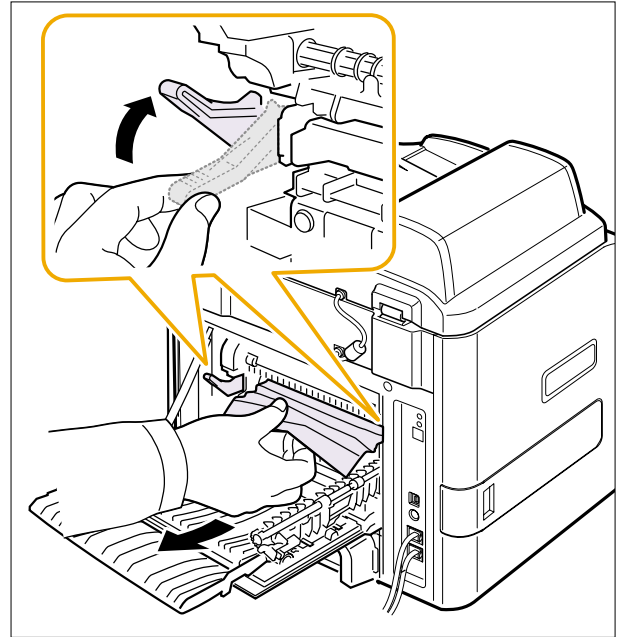

9. Return the levers, fuser door, rear cover stopper, and duplex guide to their original position.
10. Close the rear cover. Printing automatically resumes.

## 6.2.8 Duplex Jam 0

1. Pull the duplex unit out of the printer .

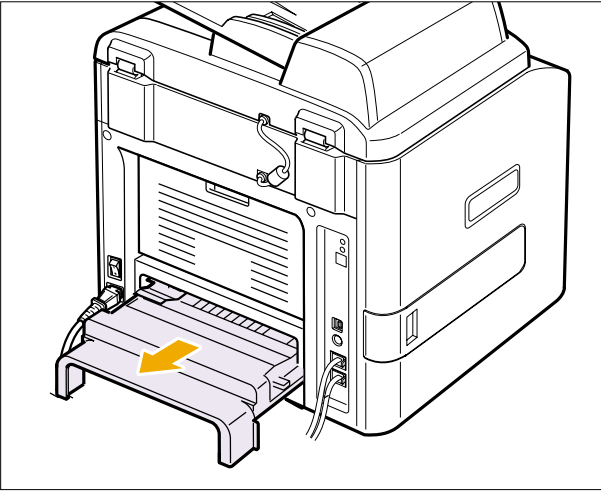

2. Remove the jammed paper from the duplex unit.

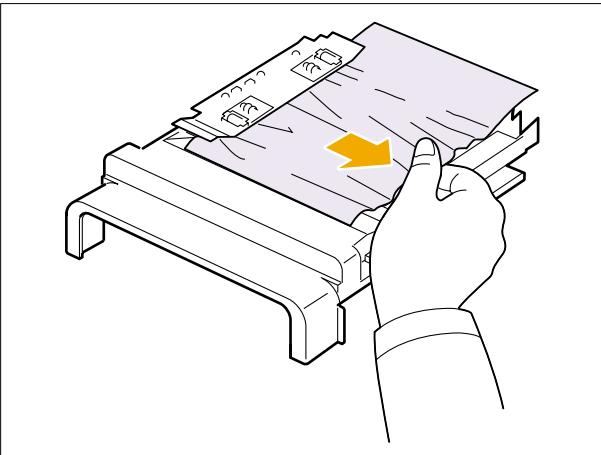

If the paper does not come out with the duplex unit, remove the paper from the bottom of the printer .



3. Push the duplex unit to the printer .

**CAUTION:** If you do not push the duplex unit in correctly, a paper jam may occur.

### 6.2.9 Duplex Jam 1

1. Open the rear cover.
2. Unfold the duplex guide fully.
3. Pull the jammed paper out.
4. Return the duplex guide and close the rear cover .  
Printing automatically resumes.

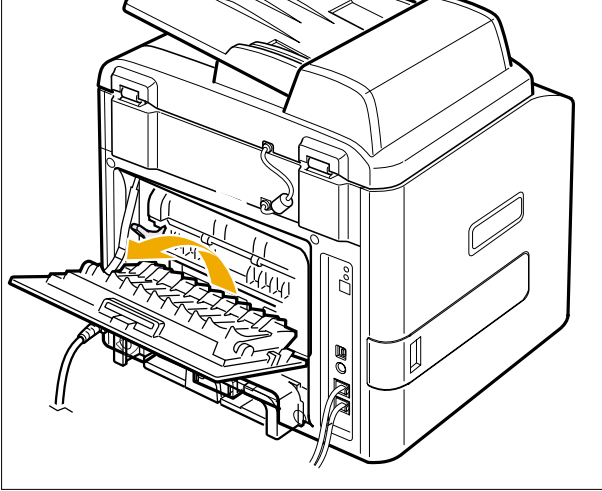



## 6.3 User Mode(Dell Laser MFP1815dn)

The table in the bellow explains the possible setting functions by user . The details about the ways to use are explained in the user manual.

In the service manual, the items are about the possible set-up by user .

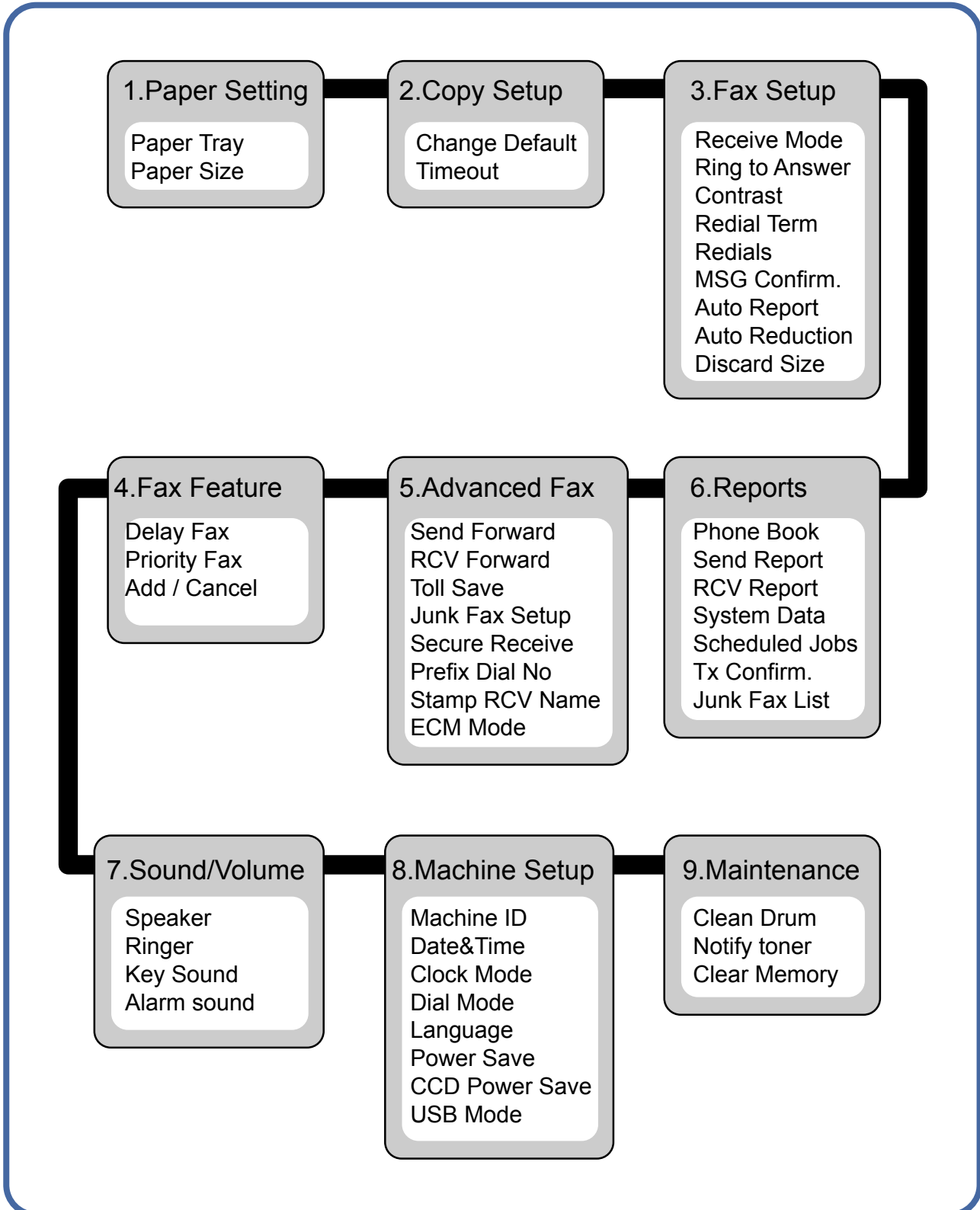







## 6.4 Tech Mode

### 6.4.1 How to Enter Tech Mode

In service (tech) mode, the technician can check the machine and perform various test to isolate the cause of a malfunction.

While in Tech mode, the machine still performs all normal operations.

#### To enter the Tech mode

To enter the Tech mode, press  →  →  →  →  →  sequence, and the LCD briefly displays 'TECH', the machine has entered service (tech) mode.

### 6.4.2 Setting-up System in Tech Mode

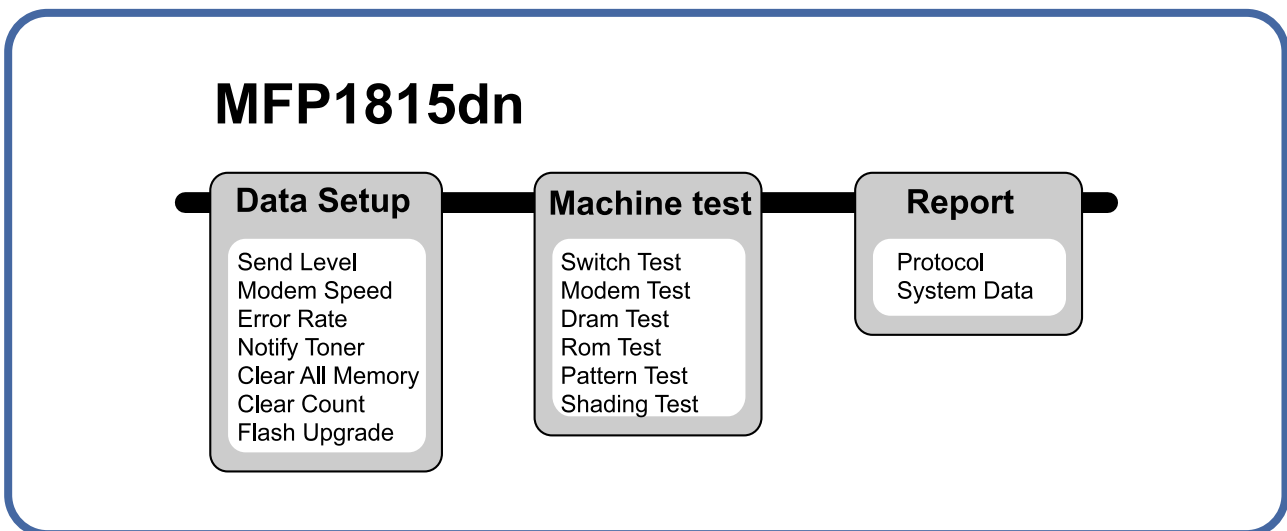

## 6.4.3 Data Setup

### SEND LEVEL

You can set the level of the transmission signal. Typically, the Tx level should be under -12 dBm.

**Caution :** *The Send Fax Level is set at the best condition in the shipment from factory. Never change settings arbitrarily.*

### DIAL MODE

This function can choose dial method.

\*Default : Dial(Dial/Pulse)

### MODEM SPEED

You can set the maximum modem speed.

Communication is done with modem speed automatically set at lower speed when communicating with a slower speed modem since communication is done on the standard of the side where modem speed is low for transmission/reception. It is best set 33.6Kbps as default setting.

### ERROR RATE

When the error rate is about exceed the set value, the Baud rate automatically adjusts to 2400 bps.

This ensures that the error rate remains below the set value.

You can select the rate between 5% and 10%.

### CLEAR ALL MEMORY

The function resets the system to factory default settings.

This function is used to reset the system to the initial value when the product is functioning abnormally. All the values are returned to the default values, and all the information, which was set by the user, will be erased.

#### < Method >

1. Select the [MEMORY CLEAR] at the TECH MODE.
2. Push the ENTER button.
3. Select your country. (There are four country groups. Refer to the table below.)
4. Push the ENTER button then it will clear all memory.

**NOTICE :** *Always perform a memory clear after replacing the main board. Otherwise, the system may not operate properly.*

Country Group	USA/Canada	UK	Russia	Southafrica
Country	USA/Canada Mexico Brazil	UK Germany France Italy Spain Austria Netherlands Belgium Portugal Pakistan Sweden Norway Denmark Finland Switzerland Greece Ireland Turkey	Russia India Oman Poland Bangladesh Kuwait Moroco Algeria  UAE Bahrain Srilanka Saudi Arabia Chile Peru Argentina Hungary Romania Bulgaria Czech	South Africa

## FLASH UPGRADE

The Firmware Upgrade function has two methods, Local and Remote.

### (1) Local Machine

#### • RCP(Remote Control Panel) mode

This method is for Parallel Port or USB Port. Connect to PC and activate RCP(Remote Control Panel) to upgrade the Firmware.

#### < Method >

How to Update Firmware using RCP

1. Connect PC and Printer with Parallel Cable or USB Cable.
2. Execute RCP and select Firmware Update.
3. Search Firmware file to update with Browse Icon.
4. Click Update icon, firmware file is transmitted to Printer automatically and printer is initialized when finished.
5. Click Refresh icon and check what is updated.

#### • DOS Command mode

This method is just for Parallel Port. Connect to PC with Parallel cable and enter DOS Command to upgrade the Firmware.

#### < Method >

1. The first of all, need the files : down.bat, down\_com.bin, fprt.exe, and Rom File: file name for upgrade. Save the files in the same folder.
2. In the DOS, input as below and push the enter key. Then, it will be automatically upgraded.
3. There are two commands for the conditions of product.
  - \* When the product is in idle condition **down "rom file"**
  - \* When the product is in Ready condition (TECH MODE → DATA SETUP → FLASH UPGRADE → LOCAL) **fprt "rom file"**
4. Do not turn off the power while upgrading process.

### (2) Remote FAX

This is a function that a fax with the latest firmware sends files to a fax in long distance through telephone line.

#### < Method >

1. Operate a fax with the latest firmware to prepare it being upgrade.  
(TECH MODE → DATA SETUP → FLASH UPGRADE → REMOTE)
2. Input the fax number, which needs to be upgraded.  
(Several faxes can be upgrade at the same time. In this case, enter the each fax number .)
3. After push the enter button, send the firmware file by calling to the appointed number.  
(Around 10~15 minutes needs to send the file.)

#### < Caution >

1. sending and receiving fax must be the same model.
2. A sending fax must be set up as ECM mode, and a receiving memory must be set up as 100%.  
If not, the function operates abnormally.

## 6.4.4 Machine Test

### SWITCH TEST

Use this feature to test all keys on the operation control panel. The result is displayed on the LCD window each time you press a key.

### MODEM TEST

Use this feature to hear various transmission signals to the telephone line from the modem and to check the modem. If no transmission signal sound is heard, it means the modem part of the main board malfunctioned.

### DRAM TEST

Use this feature to test the machine's DRAM. The result appears in the LCD display. If all memory is working normally, the LCD shows << O K >>

### ROM TEST

Use this feature to test the machine'S ROM. The result and the software version appear in the LCD display.

- FLASH VER : 1.00 V
- ENGINE VER :1.00V

### PATTERN TEST

Using this pattern printout, you can check if the printer mechanism is functioning properly . It is needed in the production progress. Service person doesn't need to use it.

### SHADING TEST

The function is to get the optimum scan quality by the specific character of the CCD(Charge Coupled Device). If the copy image quality is poor , perform this function to check the condition CCD unit.

#### < Method >

1. Select the [ADJUST SHADING] at the TECH MODE.
2. Push the SET UP button then an image will be scanned.
3. After the scan, CCD SHADING PROFILE will be print out.
4. If the printed image is different to the image, the CCD is defect.

**NOTICE :** When you test CCD, make sure that the cover is closed.

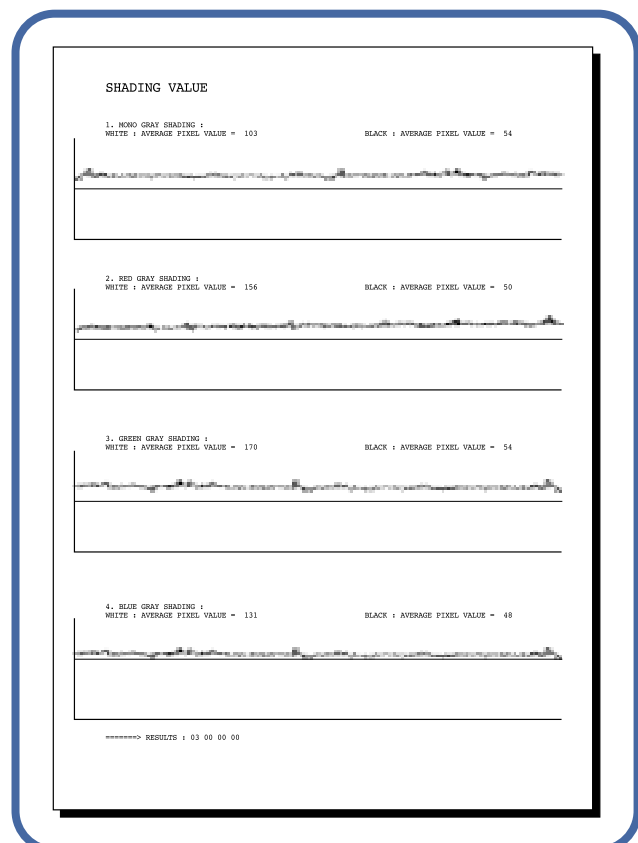

## 6.4.5 Report

---

### **PROTOCOL LIST**

This list shows the sequence of the CCITT group 3 T.30 protocol during the most recent sending or receiving operation. Use this list to check for send and receive errors. If a communication error occurs while the machine is in TECH mode, the protocol list will print automatically.

### **SYSTEM DATA**

This list provides a list of the user system data settings and tech mode settings.

## 6.5 Engine Test Mode







The Engine Tests Mode supplies useful functions to check the condition of the engine. It tests the condition of each device and displays the result of the test on the LCD. It is classified into 5 functions (0~4), and are shown below .

### Outline

- In order to enter "Engine Test " mode,,the method should be especial because this mode is developed for related engineers, not for users
- After Entering the mode,the message,"Engine Test Mode " is displayed..
- On the mode,an engineer should press the "Menu Key=>#=>1=>9=>3=>1 " to search each function he would like to test..
- Turn the power off,after the test is entirely end.

### 6.5.1 To enter the Engine Test Mode

#### To enter the Engine Test mode

Press  →  →  →  →  →  sequence, and the LCD briefly displays 'Engine Test', the machine has entered Engine Test Mode.

### 6.5.2 Diagnostic

NO.	Sub No.	Engine test	Remark
0	1	Motor Test	1 : On, 2 : Off
	2	PickUp Test	1 : On, 2 : Off
	3	Fan Test	1 : On, 2 : Off
	4	Manual Clt Test	1 : On, 2 : Off
	5	PTL Test	1 : On, 2 : Off
1	1	LSU Motor Test	1 : On, 2 : Off
	2	LSU Hsync Test	1 : On, 2 : Off
	3	LD Test	1 : On, 2 : Off
2	1	Feed Sen Test	Check : Check Start
			Next : Next Sensor Check
	2	Exit Sen Test	Check : Check Start
			Next : Next Sensor Check
	3	Cover Sen Test	Check : Check Start
			Next : Next Sensor Check
	4	Empty Sen Test	Check : Check Start
Next : Next Sensor Check			
5	Manual Sen Text	Check : Check Start	
		Next : Next Sensor Check	
3	1	Therm ADC 180	1 : On, 2 : Off (maintain the fusing temp. 80C)
	2	Therm ADC 140	1 : On, 2 : Off (maintain the fusing temp. 135C)
	3	Therm ADC 120	1 : On, 2 : Off (maintain the fusing temp. 160C)
	4	Therm ADC 100	1 : On, 2 : Off (maintain the fusing temp. 191C)
4	1	MHV Test	1 : On, 2 : Off (-1550V ± 50V)
	2	Dev Bias Test	1 : On, 2 : Off (-430V ± 20V)
	3	THV EN/NEG Test	1 : On, 2 : Off (-1000V +300V/-150V)
	4	THV ON (1300V)	1 : On, 2 : Off (+1300V ± 20V)
	5	THV ADC 1300V	1 : On, 2 : Off (ADC Value : 101 ± 5)
	6	THV ADC 600V~3500V	1 : On, 2 : Off (Compare each ADC Value)

### 6.5.3 Detail Description(Engine Test Mode)

Function Name	Description	Display
01.Motor Test	The main motor keeps running after the execution key is chosen and stops when the stop key is chosen.	Main Motor On(Off)
02.Pick Up Test	automatically stops, when the execution is chosen.	Tray 1,2 Solenoid On/Off
03.Fan Test	The fan keeps running after the execution key is chosen and stops when the stop key is chosen.	Fan On(Off)
04.Manual Clutch Test	The tray2,3 clutch is on for 1sec and then it automatically stops, when the execution is chosen.On this function, the main motor runs before 2sec from the point of the clutch on in order to check the clutch state.	Tray 2,3 Clutch On/Off
05.PTL Test	PTL(Pre-Transfer Lamp) is on after the execution key is chosen and it stops when the stop key is chosen.	PTL On(Off)
11.LSU Motor	Test The laser motor keeps running after the execution key is chosen and stops when the stop key is chosen.	Laser Motor On(Off)
12.LSU Hsync Test	"Laser Leady" is displayed, When the Laser Scanning Unit is ready to print. On the other case "Laser Error"	Laser Leady On(Off)
13.LD Test	"Diode On" is displayed, when the laser diode is on. On the other case "Diode Off" is displayed.	Diode On(Off)
21.Feed Sen Test	These Functions are considered to check the present state (normal or not)of the Sensors.	"Sensor Off"to " Sensor On "
22.Exit Sen Test		
23.Cover Sen Test		"Cover Open" to "Cover Close"
24.Empty Sen Test	These Functions are considered to check the present state (normal or not)of the Sensors.	"Sensor Off"to " Sensor On "
25.Manual Sen Test		
31.Them ADC 180	"current value"is displayed on the upper line of the panel, and "target value"on the bottom line. Target value is limited from "191°C" to "80°C"	Input and output value are ADC value.(refer to the ADC table)
32.Them ADC 140		
33.Them ADC 120		
34.Them ADC 100		
41.MHV Test	These Functions are considered to check whether the control for HVPS is normal or not.	MHV On(Off)
42.Dev Bias Test		Dev Bias On(Off)
43.THV EN/NEG Test		THV EN/NEG On(Off)
44.THV ON(1300V)		THV On(Off)
45.THV ADC 1300V		ADC value displayed.
46.THV ADC 600V~3500		ADC value displayed.



## 6.6 Identify Sale Date

---

This function confirms the date that consumer bought product and used the product for the first time. When the consumer first operate the machine, it will start a scan and page count. The time the machine was first used is remembered.

These settings are are remembered after memory delete (Clear All Memory).

### < Method >

Press MENU, #, 1, 9, 3, # in sequence. Firmware version is displayed on LCD.

Press 1( in the number keypad) : The LCD display shows "Updated date"

Press 2( in the number keypad) : The LCD display shows "Product first use date"

## 6.7 Consumables and Replacement Parts

---

The cycle period outlined below is a general guideline for maintenance.  
The example list is for an average usage of 50 transmitted and received documents per day.  
Environmental conditions and actual use will may vary.  
The cycle period given below is for reference only.

COMPONENT	REPLACEMENT CYCLE
ADF Rubber	20,000 Pages
ADF Roller	60,000 Pages
Pick-up Roller	150,000 Pages
Friction Pad(Paper Tray)	150,000 Pages
Transfer Roller	70,000 Pages
Fuser	80,000 Pages
Toner Cartridge	4,000 Pages (A4 ISO 5% Pattern)

## 6.8 Abnormal Image Printing and Defective Roller

If abnormal image prints periodically, check the parts shown below.

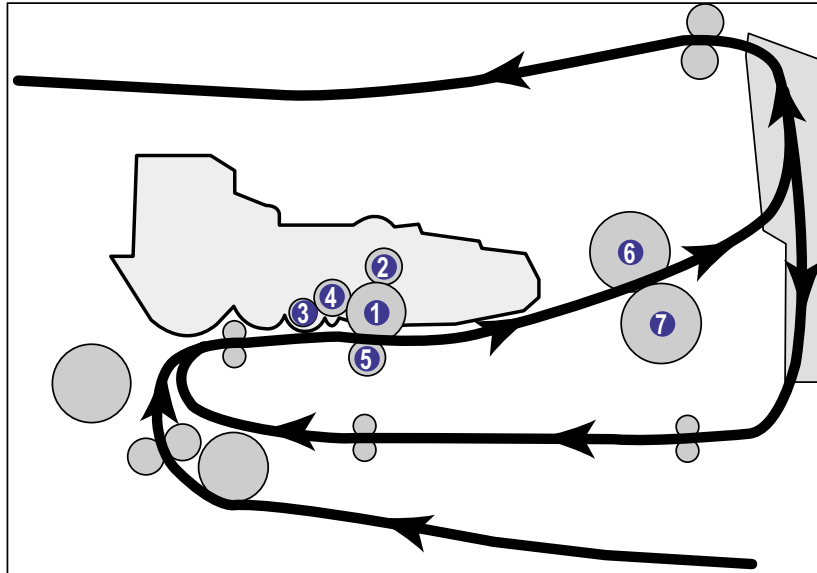

- ① OPC Drum
- ② Charge Roller
- ③ Supply Roller
- ④ Developing Roller
- ⑤ Transfer Roller
- ⑥ Heat Roller
- ⑦ Pressure Roller

No	Roller	Abnormal image period	Kind of abnormal image
1	OPC Drum	75.5mm	White spot, Block spot
2	Charge Roller	37.7mm	Black spot
3	Supply Roller	44.9mm	Horizontal density band
4	Develop Roller	35.2mm	Horizontal density band
5	Transfer Roller	47.1mm	Black side contamination/transfer fault
6	Heat Roller	77.8mm	Black spot and fuser ghost
7	Pressure Roller	75.4mm	Black side contamination

## 6.9 Error Messages

Display	Meaning	Suggested solutions
# Not Assigned Choose Another	You have tried to delete the number for the delayed fax job.	Verify the number to be deleted and try again.  OR Delete the number after the delayed fax job is sent.
Add Paper & Press Star	The bypass tray is empty in the manual feeder mode.	Load a sheet of print material and press Start. You need to press the button each page to be printed.
Invalid Cartridge	The toner cartridge you have installed is not for your printer.	Install a Dell-genuine toner cartridge, designed for your printer.
COMM. Error Retry	The printer has a communication problem.	Ask the sender to try again.
Document Jam Check Feeder	The loaded document has jammed in the ADF.	Clear the document jam. See "Clearing Jams in the ADF".
Door Open Front Door	The front cover is not securely latched.	Close the cover until it locks into place.
Duplex jam 0 Check Inside	Paper has jammed during duplex printing.	Clear the jam. See "Duplex Jam 0".
Duplex jam 1 Check Inside	Paper has jammed during duplex printing.	Clear the jam. See "Duplex Jam 1".
Enter again	You entered an unavailable item.	Enter the correct item again.
Fuser Door Open	The fuser door is not securely latched.	Open the rear cover and close the fuser door until it locks into place. For the location of the fuser door, see "Paper Exit Jam".
Group Not Available	You have tried to select a group location number where only a single location number can be used, such as when adding locations for a broadcasting operation.	Use a speed dial number or dial the number manually using the number keypad.
Hsync Error	A problem has occurred in the Laser Scanning Unit (LSU).	Unplug the power cord and plug it back in. If the problem persists, call for service
Job cancelled by user	Cancel ( ) is pressed during transmission.	Try again after a few minutes.
Job limit (15) reached	The number of jobs stored in the printer is 15 and you are trying to add 16th job.	Delete jobs in the printer or try later after completing some jobs.
Junk Fax Job Cancelled	The received fax number is the number stored in memory as junk fax number.	Change the Junk Fax Setup option.
Line Busy Try Later	The receiving party did not answer or the line is already engaged.	Try again after a few minutes.
Line Error Retry	Your printer cannot connect with a remote printer or has lost contact because of a problem with the phone line.	Try again. If the problem persists, wait for an hour or try a different phone line if possible and then try to connect again.  Or, turn the ECM mode on. See "ECM Mode".
Low Heat Error Cycle	There is a problem in the fuser unit.	Unplug the power cord and plug it Power Once back in. If the problem persists, call for service.

Display	Meaning	Suggested solutions
Memory Full Cancel or Start	The memory is full.	Delete unnecessary documents, retransmit after more memory becomes available.
Memory Full Divide the Job	The memory is full.	Split the transmission into more than one operation.
No Answer Try Later	The remote fax machine has not answered after several redial attempts.	Try again. Verify the number to make sure a fax can be received.
No Cartridge Load Cartridge	The toner cartridge is not installed.	Install the toner cartridge. See "Installing the Toner Cartridge".
No Paper Add Paper	The paper in the paper tray has run out.	Load paper in the paper tray. See "Loading Paper".
No such job	You are performing an Add/Cancel operation, but there are no jobs waiting.	Check the display to see if there are any scheduled jobs. The display should indicate if any scheduled jobs are in Standby mode, for example, Delay Fax.
Over Heat Call Service	There is a problem in the fuser unit.	Unplug the power cord and plug it back in. If the problem persists, call for service.
Open Heat Error Call Service	There is a problem in the fuser unit.	Unplug the power cord and plug it back in. If the problem persists, call for service.
Paper Jam 0 Open Front Door	Paper has jammed in the feeding area of the paper tray.	Clear the jam. See "Paper Feed Jam (tray 1)" or "Paper Feed Jam (optional tray 2)".
Paper Jam 1 Cartridge Area	Paper has jammed in the fuser area.	Clear the jam. See "Fuser Area Jam".
Paper Jam 2 Open Rear Door	Paper has jammed in the paper exit area.	Clear the jam. See "Paper Exit Jam".
Power Failure Data Lost	The power has been turned off and then on and the printer's memory has not been saved.	The printer's memory was not saved due to a power failure. The job will need to be started over.
Printer Error Cycle Power	A problem has occurred in the Laser Scanning Unit (LSU).	Unplug the power cord and plug it back in. If the problem persists, call for service.
Ready-toner 0% TONER EMPTY	The toner cartridge is empty.	Replace the toner cartridge with a new one. See "Replacing the Toner Cartridge".
Ready-toner 7% TONER LOW	The toner cartridge is almost empty.	Take out the toner cartridge and thoroughly shake it. By doing this, you can temporarily reestablish printing operations.  OR Replace the toner cartridge with a new one for the best print quality. See "Replacing the Toner Cartridge".
Scanner locked Unlock scanner	The scanner module is locked.	Unlock the scanner and press Start.
Self Diagnostic	The engine in your printer is checking some problems detected.	Please wait a few minutes.
Waiting for redial	The machine is waiting for the programmed interval to automatically redial.	Please wait a few minutes.

# 7. Troubleshooting

## 7.1 Paper Feeding Problems

### 7.1.1 Wrong Print Position

- **Description** Printing begins when the paper is in the wrong position.

Check and Cause	Solution
A defective feed sensor actuator can cause incorrect timing.	Replace the defective actuator

### 7.1.2 JAM 0

- **Description**
  1. Paper has not exited from the cassette.
  2. Jam-0 occurs if the paper feeds into the printer .

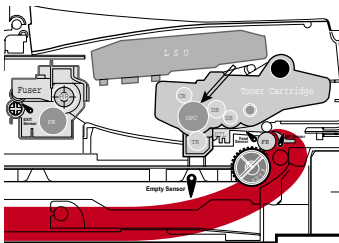

Check and Cause	Solution
1. Check the Pickup Solenoid by using Engine Test Mode : Diagnostic Mode.	1. Replace the solenoid.
2. Check if the friction pad is loose in the paper tray.	2. Replace the holder pad Assembly or if necessary.
3. Check the surface of the roller-pickup for foreign matter.	3. Clean with soft cloth dampened with IPA(Isopropyl Alcohol) or water.
4. If continuous clusters occur, check whether the assembly slot between shaft-pickup and housing-pickup become open or is broken away.	4. Replace the Roller-Pickup Ass'y.
5. If the paper feeds into the printer and Jam 0 occurs, check diagnostic mode to check feed-sensor of the engine board.	

### 7.1.3 JAM 1

• **Description**

1. Recording paper is jammed in front of or inside the fuser .
2. Recording paper is stuck in the discharge roller and in the fuser just after passing through the Actuator-Feed.

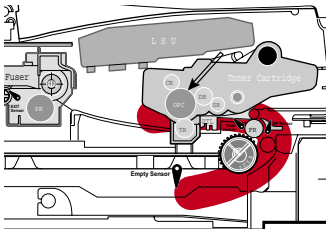

**Check and Cause**

1. If the recording paper is jammed in front of or inside the fuser, check. (The feed sensor Nith diagnostic mode the exit.)

**Solution**

1. Replace the HVPS, it necessary.

### 7.1.4 JAM 2

• **Description**

1. Recording paper is jammed in front of or inside the fuser .
2. Recording paper is stuck in the discharge roller and in the fuser just after passing through the Actuator-Feed.

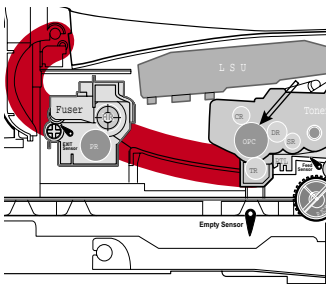

**Check and Cause**

1. If the paper is completely fed out of the printer, but Jam 2 occurs : Exit sensor is defective.
  - After the paper is completely discharged, actuator Exit should return to the original position to shut off the photo-sensor. Sometimes it takes longer than it should and does not return.
2. If the paper is rolled in the Fuser Roller:
  - This occurs when a Guide claw is broken away or transformed.
  - It occurs when the Guide slaw spring is broken away or transformed.
  - It occurs when the Heat-Roller or Pressure-Roller is seriously contaminated with toner powder.
3. Paper is accordion jammed in fuser .

**Solution**

1. Check if the exit sensor actuator is defective.
  - Check if the actuator exit is deformed (Check if the lever part is deformed in shape).
  - Check whether burrs occur in the assembly part of the actuator exit or not and if the actuator is smoothly operated.
  - Check if foreign matters and wire get caught in the actuator exit's operation.
2. If the paper is stuck in the fuser : dis - assemble the fuser and remove the jammed paper, and clean the surface of the pressure roller with dry gauze.
3. Remove the jammed paper after disassembling the fuser : Clean the surface of the pressure roller with dry gauze.
  - Remove the toner particles stained on the rib.
  - Check the assemblage and performance of the exit.

### 7.1.5 Multi-Feeding

• **Description** Multiple sheets of paper are fed at once.

Check and Cause	Solution
<ol style="list-style-type: none"> <li>1. Solenoid malfunction(the solenoid does not work properly): Perform Engine Test Mode : Diagnostic Mode.</li> <li>2. Friction-Pad is contaminated with foreign matter .(oil..)</li> <li>3. The face of paper is blended.</li> </ol>	<ol style="list-style-type: none"> <li>1. Replace the solenoid if necessary.</li> <li>2. Clean the friction-pad with soft cloth dampened with IPA(Isopropyl Alcohol).</li> <li>3. Use the smooth paper.</li> </ol>

### 7.1.6 Paper rolled in the fuser

• **Description** If contaminated at intervals of 57mm on the back of a paper .

Check and Cause	Solution
<ol style="list-style-type: none"> <li>1. Contamination of the pressure roller. (Background, Hot off set)</li> </ol>	<ol style="list-style-type: none"> <li>1. Disassemble the fuser, clean the area between the Heat-roller and Thermistor and remove the foreign matter off of the pressure roller.</li> <li>2. If background appears badly in the printing, fix it by referring to the solutions for background.</li> </ol>



### 7.1.7 Paper rolled in the OPC

• **Description** Paper is rolled up in the OPC.

Check and Cause	Solution
<ol style="list-style-type: none"> <li>1. Paper is too thin.</li> <li>2. The face of paper is curled.</li> </ol>	<ol style="list-style-type: none"> <li>1. Recommend to use normal paper thickness.</li> <li>2. How to remove the rolled paper in the OPC.                             <ul style="list-style-type: none"> <li>• Remove the paper while turning the OPC against the ongoing direction.</li> <li>• Clean fingerprints on the OPC softly with soft cloth dampened with IPA(Isopropyl Alcohol) or tissue.</li> </ul> </li> </ol>

### 7.1.8 Defective ADF

• **Description** ADF (Automatic document Feeder) is not properly operated.

Check and Cause	Solution
<ol style="list-style-type: none"> <li>1. Check if ADF rubber and HOLDER rubber are damaged.</li> <li>2. Check if the document sensors of ADF Ass'y (3 paper sensors) are normal.</li> </ol>	<ol style="list-style-type: none"> <li>1. Replace the contaminated or damaged part.</li> <li>2. If you cannot confirm the damaged part with the naked eye, try to replace the ADF Ass'y.</li> </ol>

## 7.2. Printing Problems (malfunction)

### 7.2.1 Defective Operation (LCD WINDOW ■■■ ) Display

- **Description** Strange characters are displayed on the OPE Panel and buttons are not operated.

Check and Cause	Solution
<ol style="list-style-type: none"> <li>1. Clear the memory.</li> <li>2. Check if OPE HARNESS is connected to the Connection B'd correctly.</li> </ol>	<ol style="list-style-type: none"> <li>1. Try again after clearing the memory.</li> <li>2. After confirming that OPE HARNESS is connected to the Main B'd correctly, if it is so, then replace the OPE Ass'y and Main Board in sequence.</li> </ol>

### 7.2.2 Defective LCD Operation

- **Description** Defective LCD Operation

Check and Cause	Solution
<ol style="list-style-type: none"> <li>1. Clear the memory.</li> <li>2. Confirm to catch a click sound, while a key on the OPE panel is pressed on.</li> </ol>	<ol style="list-style-type: none"> <li>1. The key is wrong itself or wrongly assembled.</li> <li>2. Even after the key has been replaced, it is still wrong, try to replace the OPE Ass'y and the Main B'd in sequence.</li> </ol>

### 7.2.3 Not functioning of the fuser gear due to melting away

- **Description** The Motor breaks away from its place due to gear melting away .

Check and Cause	Solution
1. Check the Heat Lamp.	1. Replace the Fuser.  2. Replace the Main PBA.  3. Replace the SMPS.

### 7.2.4 Paper Empty

- **Description** Paper empty sign on the display panel is on even when paper is loaded in the cassette.

Check and Cause	Solution
1. Bending or deformation of the actuator of the paper sensor.  2. The function of the Main PBA is defective Perform Engine Test Mode : Perform Engine Test Mode.	1. Replace the defective actuator.  2. Replace the Main PBA.

### 7.2.5 Paper Empty without indication

- **Description** Paper empty sign does not come on when the paper cassette is empty .

Check and Cause	Solution
1. Bending or deformation of the actuator of the paper sensor.  2. The function of the Main PBA is defective Perform.  3. The Connecting wire between the sensor and HVPS would be disconnected.	1. Replace the defective actuator.  2. Replace the Main PBA.  3. Connect the wire properly.

## 7.2.6 Door Open

- **Description** The ERROR lamp is on even when the print Door is closed.

Check and Cause	Solution
<ol style="list-style-type: none"> <li>1. The hook lever in the Front Cover may be defective.</li> <li>2. Check the Connector(CN1) and Circuit of the Cover Switch department in the Main PBA.</li> </ol>	<ol style="list-style-type: none"> <li>1. Replace the hook lever, if defective.</li> <li>2. Check the insertion of the Door Open S/W Connect.</li> <li>3. Replace the Main PBA or Door Open S/W.</li> </ol>

## 7.2.7 No Beep on when the Door is open

- **Description** The ERROR lamp does not come on even when the printer Door is open.

Check and Cause	Solution
<p>Check the Connector(CN1) and Circuit of the Cover Switch department in the Main PBA.</p>	<ol style="list-style-type: none"> <li>1. Check the insertion of the Door S/W Connect.</li> <li>2. Replace the Main PBA or Door Open S/W.</li> </ol>

### 7.2.8 Defective Motor operation

• **Description** Main Motor is not driving when printing, and paper does not feed into the printer , resulting 'Jam 0'.

Check and Cause	Solution
1. Motor harness or sub PCB may be defective.  2. Perform Engine Test Mode diagnostic code 0 and Check the Motor operation.	1. Check the Motor harness, replace it, if defective.  2. Replace the SMPS, if necessary.

### 7.2.9 No Power

• **Description** When system power is turned on, all lamps on the operator panel do not come on.

Check and Cause	Solution
1. Check if the power input and SMPS output are normal.  2. Check for defective of LCD-Panel on the front-cover if the LCD of Panel does not appear after normal warming-up.	1. Replace the power supply cord or SMPS.  2. Replace the control board.  3. Replace the LCD-panel.

### 7.2.10 Vertical Line Getting Curved

- **Description** When printing, vertical line gets curved.

Check and Cause	Solution
1. If the supply of +24v is unstable in the Main Control board linking with LSU, check drive by Engine Test Mode : Diagnostic Code 1 LSU Motor on.	1. Replace LSU.  2. Replace the Main Control board.

## 7.3 Printing Quality Problems

### 7.3.1 Vertical Black Line and Band

- **Description** 1. Straight thin black vertical line occurs in the printing.  
2. Dark black vertical band occur in the printing.



Check and Cause	Solution
<ol style="list-style-type: none"> <li>1. Damaged develop roller in the Developer. Deformed Doctor-blade.</li> <li>2. Scratched surface of the charge roller in the developer.</li> <li>3. Partial depression or deformation on the surface of the transfer roller.</li> </ol>	<ol style="list-style-type: none"> <li>1. If causes 1 and 2 occur in the developer cartridge, replace the developer and try to print out.</li> <li>2. Replace the transfer roller if occurred as No. 3.</li> </ol>

### 7.3.2 Vertical White Line

- **Description** White vertical voids in the image.

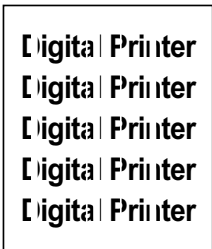

Check and Cause	Solution
<ol style="list-style-type: none"> <li>1. Foreign matter stuck onto the window of internal lenses of LSU mirror.</li> <li>2. Foreign matter or toner particles between the developer roller and blade. (In case the life of the developer has been expired, white lines or light image occur in front of the image.)</li> <li>3. It may occur when a Burr and foreign substances are on the window of the developer frame.</li> <li>4. If the fuser is defective, voids occur periodically at the top of a black image.</li> </ol>	<ol style="list-style-type: none"> <li>1. Foreign matter stuck onto the window : Clean the LSU window with recommended cleaner(IPA) Clean the window with a clean cotton swab.</li> <li>2. Foreign matter in the LSU : Open the cover of LSU and clean with a cotton swab on the surface of the reflex mirror .</li> <li>3. No 3. : Remove the foreign matter and burr of the exposure window. (Developer cartridge)</li> <li>4. No. 4. : Open the front cover and check ribs that corresponds to the position of the voids. Remove if found.</li> <li>5. If the problems are not solved, replace the developer cartridge.</li> </ol>

### 7.3.3 Horizontal Black Band

- **Description** 1. Dark or blurry horizontal stripes occur in the printing periodically .  
(They may not occur periodically.)

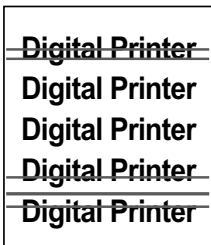

Check and Cause	Solution
1. Bad contacts of the voltage terminals to developer.  2. The rollers of developer may be stained. Charge roller = 37.7 mm Supply roller = 37 mm Develop roller = 35.3 mm Transfer roller = 45.3 mm	1. Clean each voltage terminal of the Charge, Supply, Develop and Transfer roller. (remove the toner particles and paper particles)  2. Clean the right Gear that has a relatively small gap of the teeth in the OPC.  3. If the malfunction persists, replace the developer.

### 7.3.4 Black/White Spot

- **Description** 1. Dark or blurry black spots occur periodically in the printing.  
2. White spots occur periodically in the printing.



Check and Cause	Solution
1. If dark or blurry black spots occur periodically, the rollers in the Developer may be contaminated with foreign matter or paper particles. ( Charge roller : 37.7 mm interval OPC drum : 75.5 mm interval)  2. If faded areas or voids occur in a black image at intervals of 75.5 mm, or black spots occur elsewhere, the OPC drum surface is damaged.  3. If a black image is partially broken, the transfer voltage is abnormal or the transfer roller's life has expired.	1. Run OPC cleaning Mode Print and run the Self-test 2 or 3 times.  2. In case of 75.5 mm interval unremovable in 1, cleanly remove foreign substances stuck on the OPC location equivalent to black spots and white spots with a dry duster .  3. The transfer roller guarantees 60,000 sheets printing. If the roller's life is expired, replace it.  4. In case of 37.7 mm interval unremovable in 1, take measures as to replace the developer cartridge and try to print out.  5. Clean the inside of the set against the paper particles and foreign matter in order not to cause the trouble.



### 7.3.5 Light Image

• **Description** The printed image is light, with no ghost.

Digital Printer  
 Digital Printer  
 Digital Printer  
 Digital Printer  
 Digital Printer

Check and Cause	Solution
1. Develop roller is stained when the toner of developer cartridge is almost consumed.	1. Check if the Toner Save Mode is off.
2. Ambient temperature is below than 10 °C.	2. No 1 : Replace the developer cartridge and try to print out.
3. Bad contact caused by the toner stains between the high voltage terminal in the HVPS and the one in the set.	3. No 2 : Wait 30 minutes after printer is powered on before you start printing.
4. Abnormal output from the HVPS. (Run self-test and check 1~4)	4. No3 : Clean up the contaminated area by the toner.
	5. Replace the HVPS if the problems are not solved by the above four directions.

### 7.3.6 Dark Image or a Black

• **Description** The printed image is dark.



Check and Cause	Solution
1. No charge voltage in the Main PBA. ( Perform Engine Test Mode : Diagnostic code 4 HVPS check.)	1. Clean the high voltage charge terminal.
2. Charge voltage is not turned on due to the bad contacts between power supply in the side of the Developer and charge terminal of HVPS.	2. Check the state of the connector which connects the engine board and HVPS.
	3. If steps 1 and 2 above did not correct the problem, replace the HVPS .

### 7.3.7 Uneven Density

• **Description** Print density is uneven between left and right.

Digital Printer  
 Digital Printer  
 Digital Printer  
 Digital Printer  
 Digital Printer

Check and Cause	Solution
1. The pressure force on the left and right springs of the transfer roller is not even, the springs are damaged, the transfer roller is improperly installed, or the transfer roller bushing or holder is damaged.	1. Replace both the left and right Spring Holder.
2. The life of the Developer has expired.	2. Problem with the toner cartridge, replace the toner cartridge and try to print out.
3. The toner level is not even on the developer roller due to the bad blade.	

### 7.3.8 Background

• **Description** Light dark background appears in whole area of the printing.

Digital Printer  
 Digital Printer  
 Digital Printer  
 Digital Printer  
 Digital Printer

Check and Cause	Solution
1. Recycled recording paper has been used.	1. Quality is not guaranteed when using recycled paper.
2. The life of the Developer has expired.	2. Replace the toner cartridge.
3. The up-to-down movement of the transfer roller is swift?	3. Clean the busing on the transfer roller .
4. The HVPS is normal? (Perform Engine Test Mode diagnostic code 4)	4. Replace the HVPS.

### 7.3.9 Ghost (1)

• **Description** Ghost occurs at 75.5 mm intervals of the OPC drum in the whole printing.

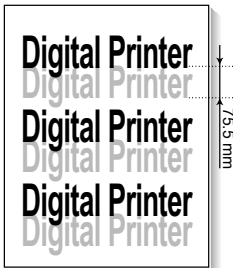

Check and Cause	Solution
1. Bad contacts caused by contamination from toner particles between high voltage terminal in the main body and the electrode of the Developer.	1. Clean the contaminated terminals.
2. Bad contacts caused by contamination from toner particles between high voltage terminal in the main body and the one in the HVPS board.	2. Problem in the toner cartridge, replace the toner cartridge and try to print out.
3. The life of developer is expired.	3. Replace the engine board if not solved by the above directions 1-2.
4. Transfer roller lifetime(60,000 sheets) has expired.	4. If not solved by the direction 3, check the transfer roller lifetime and replace it.
5. Abnormal low temperature(below 10°C).	5. Wait about 1 hour after power on before using printer.
6. Damaged cleaning blade in the developer.	6. Problem in the toner cartridge, replace the toner cartridge and try to print out.

### 7.3.10 Ghost (2)

• **Description** Ghost occurs at 75.5 mm intervals of the OPC drum in the whole printing. (When printing on card stock or transparencies using manual feeder)

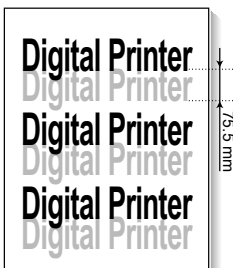

Check and Cause	Solution
When printing on card stock thicker than normal paper or transparencies such as OHP , higher transfer voltage is required.	Select 'Thick Mode' on paper type menu from the software application and after use, we recommend returning to the original Mode.

### 7.3.11 Ghost (3)

• **Description** White ghost occurs in the black image printing at 35.2 mm intervals.



Check and Cause	Solution
<ol style="list-style-type: none"> <li>1. The life of the developer may be expired.</li> <li>2. The abnormal voltage and bad contact of the terminal of the supply roller</li> </ol>	<ol style="list-style-type: none"> <li>1. Problem in the toner cartridge, replace the toner cartridge and try to print out.</li> <li>2. Check the approved voltage of the supply roller and contact of the terminal and adjust if necessary.</li> </ol>

### 7.3.12 Ghost (4)

• **Description** Ghost occurs at 77.8 mm intervals.



Check and Cause	Solution
The temperature of the fuser is maintained high.	<ol style="list-style-type: none"> <li>1. Disassemble the fuser and remove the contaminated toner particles on the roller and clean the foreign matter between Thermistor and Heat roller. ( ▲Caution: can be deformed)</li> </ol>

### 7.3.13 Stains on the front of the page

• **Description** The background on the face of the printed page is stained.



Check and Cause	Solution
<ol style="list-style-type: none"> <li>1. Toner leakage due to improperly sealed developer.</li> <li>2. If the transfer roller is contaminated, stains on the face of page will occur.</li> </ol>	<ol style="list-style-type: none"> <li>1. Replace the toner cartridge.</li> <li>2. If the transfer roller is contaminated, run PC Cleaning Mode Print 2 or 3 times. And perform Self-Test 2 or 3 times to remove contamination.</li> </ol>

### 7.3.14 Stains on back of the page

- **Description** The back of the page is stained at 47.1 mm intervals.

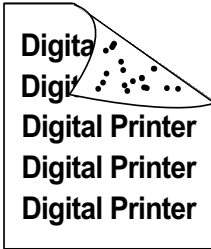

Check and Cause	Solution
1. Transfer roller is contaminated.	1. Perform the OPC Cleaning Mode Print 2 or 3 times. Run Self-Test to remove the contamination of the transfer roller.
2. Pressure roller is contaminated.	2. Replace the transfer roller if contaminated severely.
	3. Disassemble the fuser and clean the H/R(Heat Roller) and P/R(Pressure roller). And check the area between H/R and Thermistor. If contaminated, clean the area is should not be deformed.

### 7.3.15 Blank Page Print out (1)

- **Description** Blank page is printed.



Check and Cause	Solution
Bad ground contacts in OPC and/or developer.	Remove contamination of the terminals of the toner cartridge and the printer.

### 7.3.16 Blank Page Print out (2)

- **Description**
  1. Blank page is printed.
  2. One or several blank pages are printed.
  3. When the printer turns on, several blank pages print.

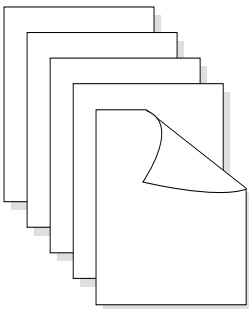

Check and Cause	Solution
1. Bad ground contacts in OPC and/or developer.	1. Remove contamination of the terminals of the toner cartridge.
2. Abnormal solenoid.	2. Perform the engine self test using Engine Test Mode diagnostic Mode code 0 if the Solenoid is normal.
	3. If not solved by the above directions 1-2, Replace the engine board.
	4. Turn the power off, clear the print job on the computer, and try printing again.

## 7.4 Fax & Phone Problems

### 7.4.1 No Dial Tone

- **Description** While on-hook button is pressed, there is no dial tone.

Check and Cause	Solution
<ol style="list-style-type: none"> <li>1. Check if the telephone line cord is connected to TEL LINE correctly.</li> <li>2. Check if it makes CLICK sound while OHD key is pressed.</li> <li>3. Check the connection of HARNESS between the LIU and the Main B'd.</li> <li>4. Check if the SPEAKER is connected correctly.</li> </ol>	<ol style="list-style-type: none"> <li>1. If the telephone cord is normal but there is no dial tone, then try to replace the LIU B'd.</li> <li>2. If you cannot hear the OHD CLICK sound, the OPE Ass'y may be defective. Try to replace the OPE Ass'y.</li> <li>3. Check the Speaker connection, and try to replace it.</li> <li>4. Lastly, try to replace the Main B'd.</li> </ol>

### 7.4.2 Defective MF DIAL

- **Description** The MF DIAL is not functioning.

Check and Cause	Solution
<ol style="list-style-type: none"> <li>1. Check if the telephone line is connected correctly .</li> <li>2. While the BUTTON KEY is pressed, check to catch a CLICK sound.</li> <li>3. Check the connection of HARNESS between the LIU and the Main PBA.</li> </ol>	<ol style="list-style-type: none"> <li>1. If you cannot catch the OHD CLICK sound, the OPE Ass'y may be defective. Try to replace the OPE Ass'y.</li> <li>2. If you can catch a CLICK sound, after checking the connection of HARNESS between the LIU and the Main PBA, try to replace the HARNESS.</li> <li>3. The problem still persists, then replace the LIU and the main B'd in sequence.</li> </ol> <p><b>Notes:</b> Product supports the MF DIAL type only.</p>

### 7.4.3 Defective FAX FORWARD/RECEIVE

- **Description** The FAX FORWARD/RECEIVE is not functioning.

Check and Cause	Solution
<ol style="list-style-type: none"> <li>1. Check if you can catch a dial tone by pressing OHD.</li> <li>2. Check if you can catch a RECEIVE tone while MODEM testing in the TECH Mode.</li> </ol>	<ol style="list-style-type: none"> <li>1. If the MODEM testing is normal and there is no dial tone, then try to replace the LIU B'd.</li> <li>2. If the MODEM testing is abnormal, try to replace the Main B'd.</li> </ol>

### 7.4.4 Defective FAX FORWARD

- **Description** RECEIVE is functioning, but FORWARD is not functioning or the received data are broken.

Check and Cause	Solution
<ol style="list-style-type: none"> <li>1. Check if there is NOISE when pressing on-hook dial.</li> <li>2. Check the RECEIVE condition by trying to forward a FAX to another fax machine from the forwarding side FAX.</li> <li>3. Check if the telephone line connected to the Product is contaminated or gets stripped off or down.</li> </ol>	<ol style="list-style-type: none"> <li>1. If it makes NOISE while using on-hook dial, replace or repair the telephone line.</li> </ol>

### 7.4.5 Defective FAX RECEIVE (1)

• **Description** FORWARD is functioning, but RECEIVE is not functioning or the received data are broken.

Check and Cause	Solution
<ol style="list-style-type: none"> <li>1. Check if there is NOISE when pressing on-hook dial.</li> <li>2. Check the RECEIVE condition by trying to receive a FAX at another fax machine.</li> </ol>	<ol style="list-style-type: none"> <li>1. If it makes NOISE while on-hooking, replace or repair the telephone line.</li> </ol>

### 7.4.6 Defective FAX RECEIVE (2)

• **Description** The received data are lengthened or cut in the printing.

Check and Cause	Solution
<ol style="list-style-type: none"> <li>1. Check if there is NOISE when pressing on-hook dial.</li> <li>2. Ask to the forwarding side, check the image quality of another machine receiving a FAX additionally sent to.</li> </ol>	<ol style="list-style-type: none"> <li>1. If it makes NOISE, rearrange the telephone line. (Refer to 'Defective FAX RECEIVE'.)</li> <li>2. Check if the FAX status of the forwarding side is also normal.</li> </ol>

### 7.4.7 Defective FAX RECEIVE (3)

• **Description** The phone is ringing continuously, but it cannot receive.

Check and Cause	Solution
<p>Check if the RECEIVE Mode is TEL MODE or FAX MODE.</p>	<p>Even when the RECEIVE Mode is changed to FAX MODE, it cannot receive, then replace the LIU and the Main B'd in sequence.</p>



### 7.4.8 Defective FAX RECEIVE (4)

- **Description** The received data is reduced by more than 50% in the printing.

Check and Cause	Solution
Check the FAX status of the forwarding side.	After checking the data of the forwarding side, correct the FAX of the forwarding side.

### 7.4.9 Defective Automatic Receiving

- **Description** The automatic receiving function is not working.

Check and Cause	Solution
1. Check if the RECEIVE Mode is TEL MODE or FAX MODE.	1. If the RECEIVE Mode is set to the TEL MODE, reset it to the FAX MODE.  2. Even after the RECEIVE Mode is changed to the FAX Mode, it cannot receive, then try to replace the LIU and the Main B'd in sequence.

## 7.5 Copy Problems

### 7.5.1 White Copy

• **Description** Blank page is printed out when copy.

Check and Cause	Solution
<ol style="list-style-type: none"> <li>1. Check the Scan-Cover open.</li> <li>2. Check shading profile.</li> <li>3. Check white/black reference voltage in Main PBA.</li> </ol>	<ol style="list-style-type: none"> <li>1. Room light ca transit a thin original.</li> <li>2. Remake shading profile in the tech mode.</li> <li>3. Replace U60 if it is defective.                             <ul style="list-style-type: none"> <li>• U60-154 = 0.5V</li> <li>• U60-155 = 3.3V</li> </ul> </li> </ol>

### 7.5.2 Black Copy

• **Description** Black page is printed out when Copy.

Check and Cause	Solution
<ol style="list-style-type: none"> <li>1. Check the CCD problem in Main PBA.</li> <li>2. Check shading profile.</li> </ol>	<ol style="list-style-type: none"> <li>1. Check the CCD harness contact.</li> <li>2. Remake shading profile in the tech mode.</li> </ol>

### 7.5.3 Abnormal noise

- **Description** There is noise when copy.

Check and Cause	Solution
<ol style="list-style-type: none"> <li>1. Check the Scanner Motor and any mechanical disturbance.</li> <li>2. Check the Motor Driver in Driver PBA.</li> </ol>	<ol style="list-style-type: none"> <li>1. Check the right position of the Scanner Motor , and check the any mechanical disturbance in the CCD carriage part.</li> <li>2. If any driver is defective, replace it.                             <ul style="list-style-type: none"> <li>• Connection PBA U4-1, 19 or U5-1, 19=0V to 24V swing signal when operating.</li> </ul> </li> </ol>

### 7.5.4 Defective Image Quality

- **Description** The copied image is light or bad.

Check and Cause	Solution
<ol style="list-style-type: none"> <li>1. Check shading profile.</li> <li>2. Check the gap between original and scanner glass.</li> <li>3. Check printing quality.</li> </ol>	<ol style="list-style-type: none"> <li>1. Remake shading profile in the tech mode.</li> <li>2. The gap above 0.5 mm can cause a blurred image.</li> <li>3. See "Print" troubleshooting.</li> </ol>

## 7.6 Scanning Problems

### 7.6.1 Defective PC Scan

- **Description** The PC Scan is not functioning at all.

Check and Cause	Solution
<ol style="list-style-type: none"> <li>1. Check the Cable (USB or Parallel)</li> <li>2. Check if the driver is installed properly.</li> <li>3. Check if copy function operates normally.</li> </ol>	<ol style="list-style-type: none"> <li>1. If the PC and the cable are not connected properly , reconnect it.</li> <li>2. After confirming that it is proper by performing a PC printing test related to driver setup, if it is not so, rein - stall it. (Refer to User's Manual.)</li> <li>3. If copy function works, replace the Main PBA. If copy function doesn't work, replace the CCD Ass'y and try again.</li> </ol>

### 7.6.2 Defective Image Quality of PC Scan

- **Description** The image PC scanned is not clear or bad.

Check and Cause	Solution
<ol style="list-style-type: none"> <li>1. Check the waveform form by performing a CCD test in TECH Mode.</li> <li>2. Check if the resolution is set too low in PC Scan options. (Refer to User's Manual.)</li> </ol>	<ol style="list-style-type: none"> <li>1. If the CCD waveform form is abnormal, try to replace the CCD Ass'y.</li> <li>2. If the resolution is set to low , let the user be acquaint- ed with the using method well.</li> </ol>

## 7.7 Toner Cartridge Service

It is not guaranteed for the default caused by using other toner cartridge other than the cartridge supplied by the or caused by non-licensed refill production.

### 7.7.1 Precautions on Safe-keeping of Toner Cartridge

Excessive exposure to direct light more than a few minutes may cause damage to the cartridge.

### 7.7.2 Service for the Life of Toner Cartridge

If the printed image is light due to the life of the toner , you can temporarily improve the print quality by redistributing the toner(Shake the toner cartridge), however, you should replace the toner cartridge to solve the problem thoroughly .

#### 7.7.2. 1 Redistributing Toner

When the toner cartridge is near the end of its life, white streaks or light print occurs. The LCD displays the warning message, "Toner Low." You can temporarily reestablish the print quality by redistributing the remaining toner in the cartridge.

1. Open the Front Cover.

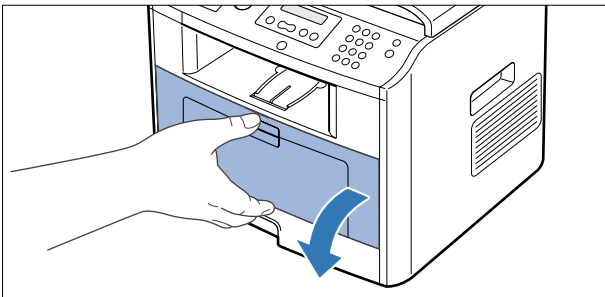

2. Lightly pushing the used cartridge down, pull it out.

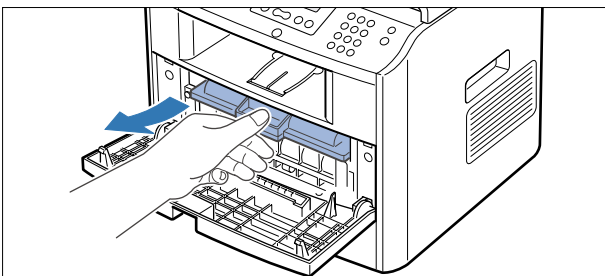

*Note : Help the environment by recycling your used toner cartridge. Refer to the recycling brochure packed with the toner cartridge for details.*

3. Unpack the new toner cartridge and gently shake it horizontally four or five times to distribute the toner evenly inside the cartridge.

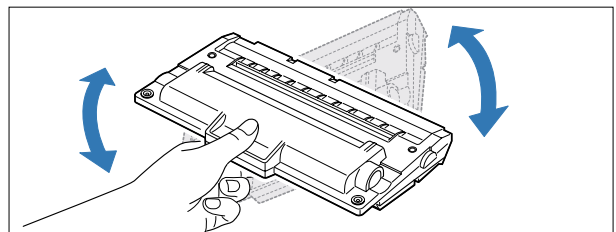

4. Save the box and the cover for shipping. Slide the new toner cartridge in until it locks into place.

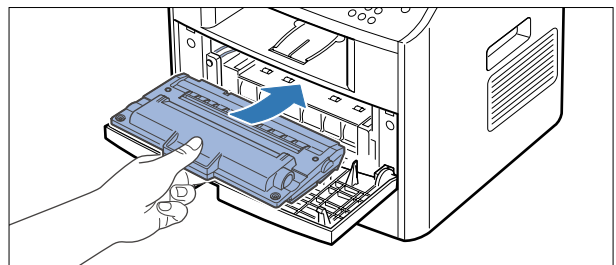

5. Close the front cover.

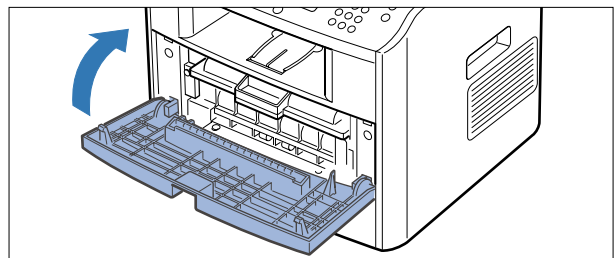

### 7.7.3 Service for Judgement of Inferior Expendables and the Standard of Guarantee

Please refer to User's Manual or Instructions on Fax/Printer Expendables SVC for the judgement of inferior expendables and the standard of guarantee besides this service manual.

### 7.7.4 Signs and Measures at Poor toner cartridge

Fault	Signs	Cause & Check	Solution
<p><b>Light image and partially blank image (The life is ended.)</b></p>	<ul style="list-style-type: none"> <li>• The printed image is light or unclean and untidy.</li> <li>• Some part of the image is not printed.</li> <li>• Periodically a noise as "tick tick" occurs.</li> </ul>	<ol style="list-style-type: none"> <li>1. If the image is light or unclean and untidy printed image - Shake the developer and then recheck.                             <ul style="list-style-type: none"> <li>(1)NG: Check the weight of the developer</li> <li>(2)OK: Lack of toner, so the life is nearly closed.</li> </ul> </li> <li>2. Some part of image is not printed - Shake the developer and then recheck.                             <ul style="list-style-type: none"> <li>(1)NG: Check the weight of the developer and clean the LSU window with a cotton swab, then recheck.</li> <li>(2)OK: Lack of toner, so the life is nearly closed.</li> </ul> </li> <li>3. Periodically a noise as "tick tick" occurs - Measure the cycle and the weight of the developer.</li> <li>4. White vertical stripes on the whole screen or partly : Check the weight of the developer.</li> </ol>	<ol style="list-style-type: none"> <li>1. All of 1, 2, 3 above-                             <ul style="list-style-type: none"> <li>(1)The weight of the developer ended: 800g ± 20g</li> <li>(2)If it become better by shaking, replace with a new developer after 50-100 sheets in the closing state of the life span.</li> </ul> </li> <li>2. In case of 2-                             <ul style="list-style-type: none"> <li>If it becomes better after cleaning the LSU window, then the developer is normal. (Because of foreign substance on the LSU window, the image has not been printed partly.)</li> </ul> </li> <li>3. In case of 3-                             <ul style="list-style-type: none"> <li>If the cycle of noise is about 2 seconds, the toner inside the developer has been nearly exhausted.( Purchase and replace with a new developer after using about 200 sheets at the point of occurrence)</li> </ul> </li> <li>4. In case of 3-                             <ul style="list-style-type: none"> <li>This is a phenomenon caused by lack of toner, so replace with a new developer.</li> </ul> </li> </ol>
<p><b>Toner Contamination</b></p>	<ul style="list-style-type: none"> <li>• Toner is fallen on the papers periodically.</li> <li>• Contaminated with toner on prints partly or over the whole surface.</li> </ul>	<ol style="list-style-type: none"> <li>1. Toner is fallen on the paper periodically.                             <ul style="list-style-type: none"> <li>(1)Check the cycle of the falling of the toner.</li> <li>(2)Check the appearance of both ends of the developer OPC drum.</li> </ul> </li> <li>2.The center of the printed matter is contaminated with toner.                             <ul style="list-style-type: none"> <li>(1)Check whether foreign substances or toner are stuck to the terminal (contact point) of the developer.</li> <li>(2)Check whether the state of the terminal assembly is normal.</li> </ul> </li> </ol>	<ol style="list-style-type: none"> <li>1. If both ends of the OPC drum are contaminated with toner: Check the life of the developer. (In case of less than 820g, the life may be expired.)</li> <li>2. Check whether it could be recycled.</li> <li>3. If it cannot be recycled: Replace the developer.</li> </ol>

Fault	Signs	Cause & Check	Solution
<p><b>White Black spot</b></p>	<ul style="list-style-type: none"> <li>• Light or dark black dots on the image occur periodically.</li> <li>• White spots occur in the image periodically.</li> </ul>	<ol style="list-style-type: none"> <li>1. If light or dark periodical black dots occur, this is because the developer rollers are contaminated with foreign substance or paper particles.                             <ol style="list-style-type: none"> <li>(1) 37.7 mm interval : Charged roller</li> <li>(2) 75.5 mm interval : OPC cycle</li> </ol> </li> <li>2. If white spots occur in a black image at intervals of 75mm, or black spots occur elsewhere, the OPC drum is damaged or foreign substance is stuck to the surface.</li> <li>3. If a black and white or graphic image is partially broken at irregular intervals, the transfer roller's life has been expired or the transfer voltage is abnormal.</li> </ol>	<ol style="list-style-type: none"> <li>1. In case of 1 above - Run OPC Cleaning Mode Print 4-5 times repeatedly to remove. Especially check foreign substance on the OPC surface, then remove them with a clean gauze moistened with IPA(Isopropyl Alcohol) not to damage OPC if necessary. <b>Never use usual alcohol.</b></li> <li>2. In case of 2 If they are not disappeared by running OPC Cleaning Mode Print 4-5 times.                             <ul style="list-style-type: none"> <li>: at intervals of 37.7 mm - Replace the developer.</li> <li>: at intervals of 75.5 mm - Remove foreign substance.</li> <li>: Broken image - Replace the developer according to carelessness.</li> </ul> </li> <li>3. In case of 3 - Exchange the transfer roller because the life of the transfer roller in use has been expired. (Check the transfer voltage and readjust if different.)</li> </ol>
<p><b>Recycled product</b></p>	<ul style="list-style-type: none"> <li>• Poor appearance of the developer.</li> <li>• Unclean and rough printouts.</li> <li>• Bad background in the image.</li> </ul>	<ol style="list-style-type: none"> <li>1. Poor appearance of the developer.                             <ol style="list-style-type: none"> <li>(1) Check the damage to label and whether different materials are used.</li> <li>(2) Check the appearance of parts of the developer, such as frame, hopper.</li> </ol> </li> <li>2. Unclean and rough printouts.                             <ol style="list-style-type: none"> <li>(1) Check whether foreign substance or toner are stuck to the terminal (contact point) of the developer.</li> <li>(2) Check whether the state of the terminal assembly is normal.</li> </ol> </li> </ol>	<ol style="list-style-type: none"> <li>1. In case of 1 -                             <ol style="list-style-type: none"> <li>(1) If there is an evidence of disassembling the developer.</li> <li>(2) If materials other than normal parts of the developer are added or substituted.</li> </ol> </li> <li>2. In case of 2 - If there are any abnormalities in connection with the situation of 1.                             <ol style="list-style-type: none"> <li>(1) It occurs when the developer is recycled over 2 times.</li> <li>(2) If toner nearly being expired are collected to use, it is judged as the recycled developer.</li> </ol> </li> </ol>

Fault	Signs	Cause & Check	Solution
<p><b>Ghost &amp; Image Contamination</b></p>	<ul style="list-style-type: none"> <li>• The printed image is too light or dark, or partially contaminated black.</li> <li>• Totally contaminated black. (Black image printed out)</li> <li>• The density of print-outs is too dark and ghost occurs.</li> </ul>	<ol style="list-style-type: none"> <li>1. The printed image is too light or dark, or partially contaminated black.               <ul style="list-style-type: none"> <li>(1) Check whether foreign substance or toner are stuck to the terminal (point of contact) of the developer.</li> <li>(2) Check whether the terminal assembly is normal.</li> </ul> </li> <li>2. Totally contaminated black. (Black image printed out)               <ul style="list-style-type: none"> <li>(1) Check whether foreign substances are stuck to the terminal (point of contact) of the developer and the state of assembly. (Especially check the charged roller terminal.)</li> </ul> </li> <li>3. The printed image is dark and ghost occurs.               <ul style="list-style-type: none"> <li>(1) Check foreign substance attached to the terminal (point of contact) of the developer and the state of assembly. (Especially check the developing roller terminal.)</li> </ul> </li> </ol>	<ol style="list-style-type: none"> <li>1. All of 1, 2, 3 above               <ul style="list-style-type: none"> <li>(1) Remove toner and foreign substances adhered to the contact point of the developer.</li> <li>(2) The contact point of the unit facing that of the developer also must be cleaned.</li> <li>(3) If the terminal assembly is unsafe:                   <ul style="list-style-type: none"> <li>• Fully stick the terminal to or reassemble it after disassembling.</li> <li>• Disassemble the side plate and push the terminal to be stuck, then reassemble it.</li> </ul> </li> </ul> </li> <li>2. In case of 2               <p>It is a phenomenon when the OPC drum of the developer is not electrically charged. Clean the terminals of the charged roller , then recheck it.</p> </li> <li>3. In case of 3               <p>It is a phenomenon as the developing bias voltage of the developer. Clean the terminals of the developing roller, then recheck it.</p> </li> </ol>



## 7.8 Network Problems Troubleshooting

### 7.8.1 General Problems

Problem	Solution
System does not function with some wrong values entered by mistake while configuring.	Possibly the parameters in PortThru are corrupted. Restart the system and set to factory defaults on the printer front panel or on your computer using SyncThru.
Not able to access from SNMP Manager. SyncThru is unable to automatically detect print servers.	Try pinging from the same system on which SNMP manager is running. If it does not succeed, there must be a problem with network connectivity between the manager and PortThru. If ping succeeds, verify that community names with sufficient permissions have been used.
SyncThru is unable to automatically detect print servers.	Check the environment as described in Auto Detection of Print Server. Check NetWare file server consoles for error messages regarding nodes with conflicting network numbers.
You cannot see any of DHCP server, BOOTP server or RARP server, when you want to set IP address to print server.	On Network Interface in SyncThru, you should set "Static" to "IP Address Assignment Method" in TCP/IP tab. You should set IP address, Subnet Mask and Default Gateway to print server.
Print server does not print using TCP/IP protocol.	1. Check whether TCP/IP protocol is installed in your PC. 2. Check whether your PC is on the same network with print server.
Unable to print in NetWare environment.	Use SyncThru to see if PortThru indicates that queue is serviceable. If not, the login permissions may have changed or the configuration information for queues, printers and print servers may have been changed. Verify using PCONSOLE and NWADMIN that the configuration is correct and check the job queue to see if the print job exists. Check that NetWare is enabled on PortThru. Check that the Check Job every is configured on PortThru.
The status of printer is displayed 'unknown' in SyncThru.	1. Check the protocol of your PC and install DLC/LLC or IPX/SPX protocol. 2. Assign IP Address to PortThru using the front panel.
The name of printer is displayed empty while adding a port and the printer doesn't function.	1. Check the protocol of your PC and install DLC/LLC or IPX/SPX protocol. 2. Assign IP Address to PortThru using the front panel.

### 7.8.2 Macintosh Problems

Problem	Solution
The printer name is not displayed in the Chooser.	<ol style="list-style-type: none"> <li>1. Make sure the printer is connected to network correctly .</li> <li>2. Make sure the printer is configured in SyncThru using the new name.</li> <li>3. After turning on the printer ,wait 3 minutes,then check it again.</li> <li>4. Make sure that your Macintosh is connected to the network through Ethernet.</li> <li>5. When the Macintosh and network printer are in the same network, check above items again. Otherwise check whether the router can support AppleTalk protocol. If the router can not support the AppleTalk protocol,then ask the network manager to solve this problem.</li> </ol>
The printer drops letters.	<ol style="list-style-type: none"> <li>1. Make sure the PS option is installed in your printer correctly .</li> <li>2. Make sure the SIMM provided with PS option is installed correctly . Check that the total memory is 12MB by printing a self-test page.</li> </ol>

### 7.8.3 Windows Problems

Problem	Solution
After installing PortThru,the print server name is not displayed under New Print Server in SyncThru.	<ol style="list-style-type: none"> <li>1. Verify that the printer power switch is turned on and the 'READY' message is displayed on the printer front panel.</li> <li>2. Verify that the LAN cable is plugged into the PortThru card.</li> <li>3. Verify that the second LED on the PortThru card blinks. <ul style="list-style-type: none"> <li>• If the second LED blinks regularly,turn off the printer, then turn it back on. If the problem continues,contact your local dealer .</li> <li>• If the first LED on the PortThru card does not blink, check that the card is installed snugly. If the problem continues, contact your local dealer.</li> </ul> </li> <li>4. Confirm whether the print server and the PC which searches for the New Print Server is on the same LAN. If you want to search for a New Print Server,your PC and the print server should be on the same LAN.</li> </ol>
The print server name is displayed, but the test page is not printed.	Select the Network menu from the front panel menus. Check that the test page is printed. If the Network menu is not displayed,or the test page is not printed, turn off the printer, then turn it back on.
Firmware upgrade process is completed. But upgrading is not executed.	An IP address should be assigned to upgrade the Firmware. Make sure that IP address is entered in Print Server. If an IP address is not entered,reassign it and try again.

Problem	Solution
SyncThru is unable to automatically detect printers.	<ol style="list-style-type: none"> <li>1. Check LAN cable is connected to the printers.                             <ul style="list-style-type: none"> <li>• Check LAN cable is connected to the printers yourself.</li> <li>• Make sure that there are the connected printers shown in network neighborhood. If not, check the communication status of the printers.</li> <li>• If IP address is assigned to the computers, try ping command.</li> </ul> </li> <li>2. If the protocols of NPC are disabled, DLC/LLC should be installed in the computers.                             <ul style="list-style-type: none"> <li>• If SyncThru is unable to detect printers with DLC/LLC installed in the computers, check whether NPC and PC are on the same LAN.</li> <li>• If LAN is connected by routers, SyncThru is unable to detect the printers.</li> </ul> </li> <li>3. If more than one of the protocols of NPC are enabled and DLC/LLC is installed in the computers, check NPC and PC are on the same LAN.                             <ul style="list-style-type: none"> <li>• If LAN is connected by routers, SyncThru is unable to detect the printers. In this case, one of protocols which are enabled in NPC should be installed in the computers.</li> </ul> </li> <li>4. In case that the protocol which is enabled in NPC is installed in the computers:                             <ul style="list-style-type: none"> <li>• If TCP/IP installed, check entry values of IP address, subnet mask and default gateway.</li> </ul> </li> </ol>
The printer does not print.	Try Add a Port.

### 7.8.4 SyncThru Installation Problems

Problem	Solution
"File Transfer Error" message appears when you execute Installation.	<ol style="list-style-type: none"> <li>1. Make sure the previously installed SyncThru is uninstalled.</li> <li>2. If the SyncThru is uninstalled, restart your PC.</li> <li>3. If the problem continues, In Windows 95/98, delete the "sammon.dll" file in the system directory of Windows in MS-DOS mode, restart Windows and reinstall it. In Windows NT, stop the spooler service with 'Services' in Control Panel, delete the "sammon.dll" file in the system32 directory of Windows NT, start spooler service and reinstall it.</li> </ol>
'Unable to add the Port list of Dell ports' message appears, when you add a port.	Verify that your PC restarts after installing SyncThru.

# 8

## 8. Exploded Views and Parts List

- 8.1. Main Exploded Views ..... page(8-2)
- 8.2. Cover Ass'y ..... page(8-3)
- 8.3. Middle Cover Ass'y ..... page(8-4)
- 8.4. Front Cover Ass'y ..... page(8-5)
- 8.5. Rear Cover Ass'y ..... page(8-6)
- 8.6. Frame Assembly ..... page(8-7)
- 8.7. Fuser Drive Ass'y ..... page(8-8)
- 8.8. Main Drive Ass'y ..... page(8-9)
- 8.9. MP Ass'y ..... page(8-10)
- 8.10. ADF Ass'y..... page(8-11)
- 8.17. Cover Platen Ass'y..... page(8-12)
- 8.16. OPE Unit ..... page(8-13)
- 8.15. Scanner Ass'y ..... page(8-14)
- 8.14. Cassette Ass'y ..... page(8-15)
- 8.15. Fuser Ass'y ..... page(8-16)
- 8.16. Duplex Unit ..... page(8-17)

- Deal drawings and service parts are declared for the items with higher rate of inferiority and replaceable in the level of service description only.
- If inferiority occurs, you can replace the parts by the unit declared in deal drawings and service items.

### Way to observe Part Code & Description

Part code and Description is quoted and controlled by determined standard. Refer to this determined standard, it will help with ordering Part.

- There are two kinds of Part code inscription type.

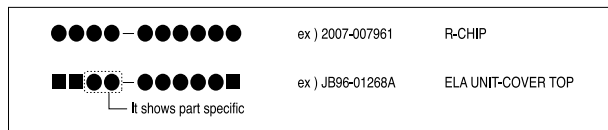

(● : figure, ■ : character (alphabet))

**Type 1** : Controlled by Company : It can be commonly used for all kinds of product SEC produce. Mostly, electronics Parts.

**Type 2** : Controlled by Division : It is used or one produce. Mostly, Mostly, mechanical Parts.

- **A/S privately used part** : It is only used for A/S .
- **Ass'y part** : Assembled by more than 2 Parts. If necessary part is not A/S Part, Ass'y part including necessary par can be used. It is shown in the diagram and drawing of SVC manual.
- Ass'y part and A/S privately used Part is distinguished by part Code and Description. The are inscription type 2. It is recognized by Part character and front side of description.

DIVISION	PART CODE	DESCRIPTION
A/S Private	**81-***** (JB81-00039A)	AS-***** (AS-USE)
ASS'Y Part	**75-***** (JB75-00068A)	MEC-***** (MEC-CHUTE)
ASS'Y Part	**92-***** (JB92-01131A)	PBA ***** (PBA MAIN-CONTROLLER)
ASS'Y Part	**97-***** (JB97-01089A)	MEA ***** (MEA UNIT-PULLEY IDLE)

# 8.1 Main Exploded Views

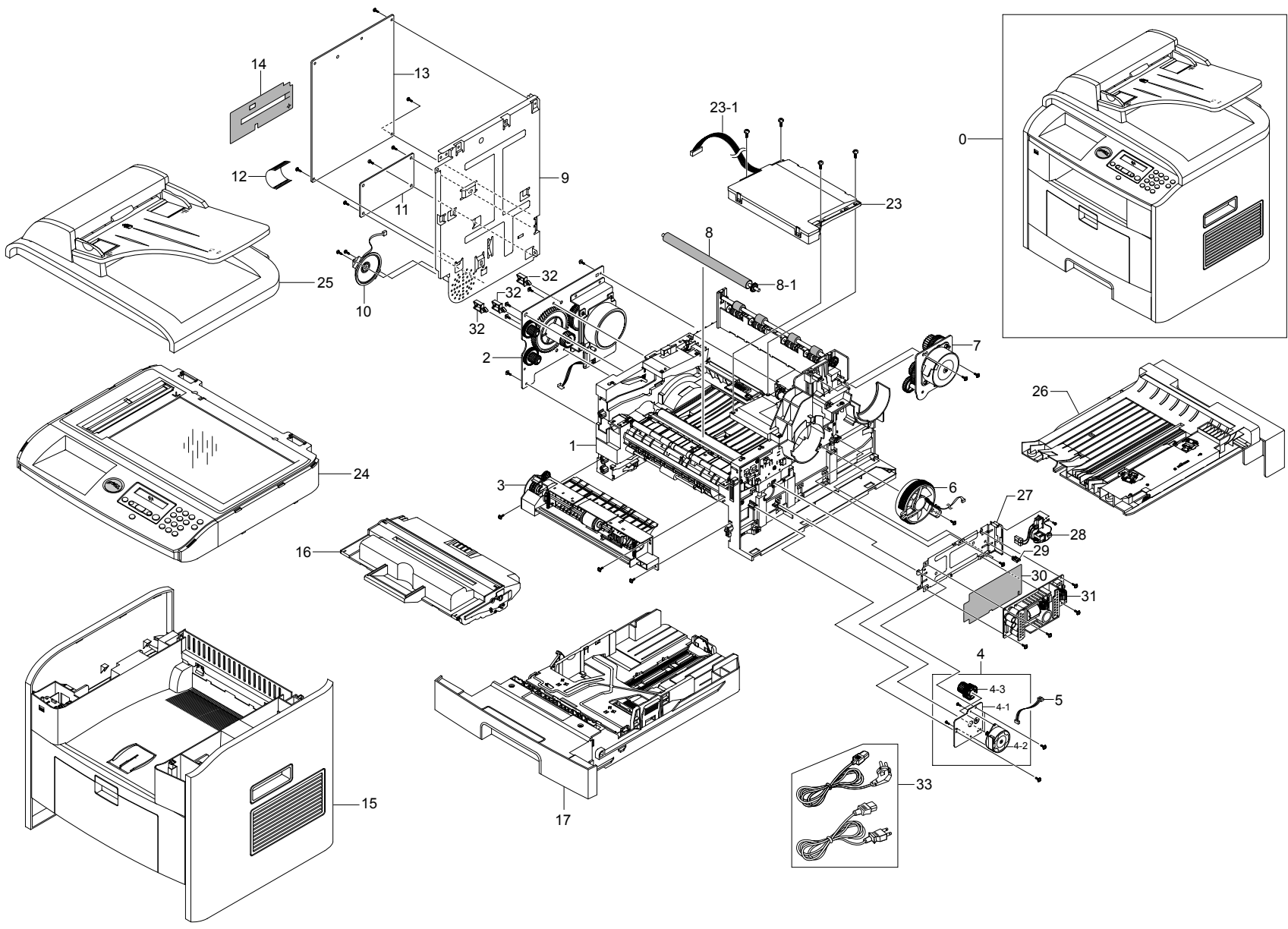

## 8.2 Cover Ass'y

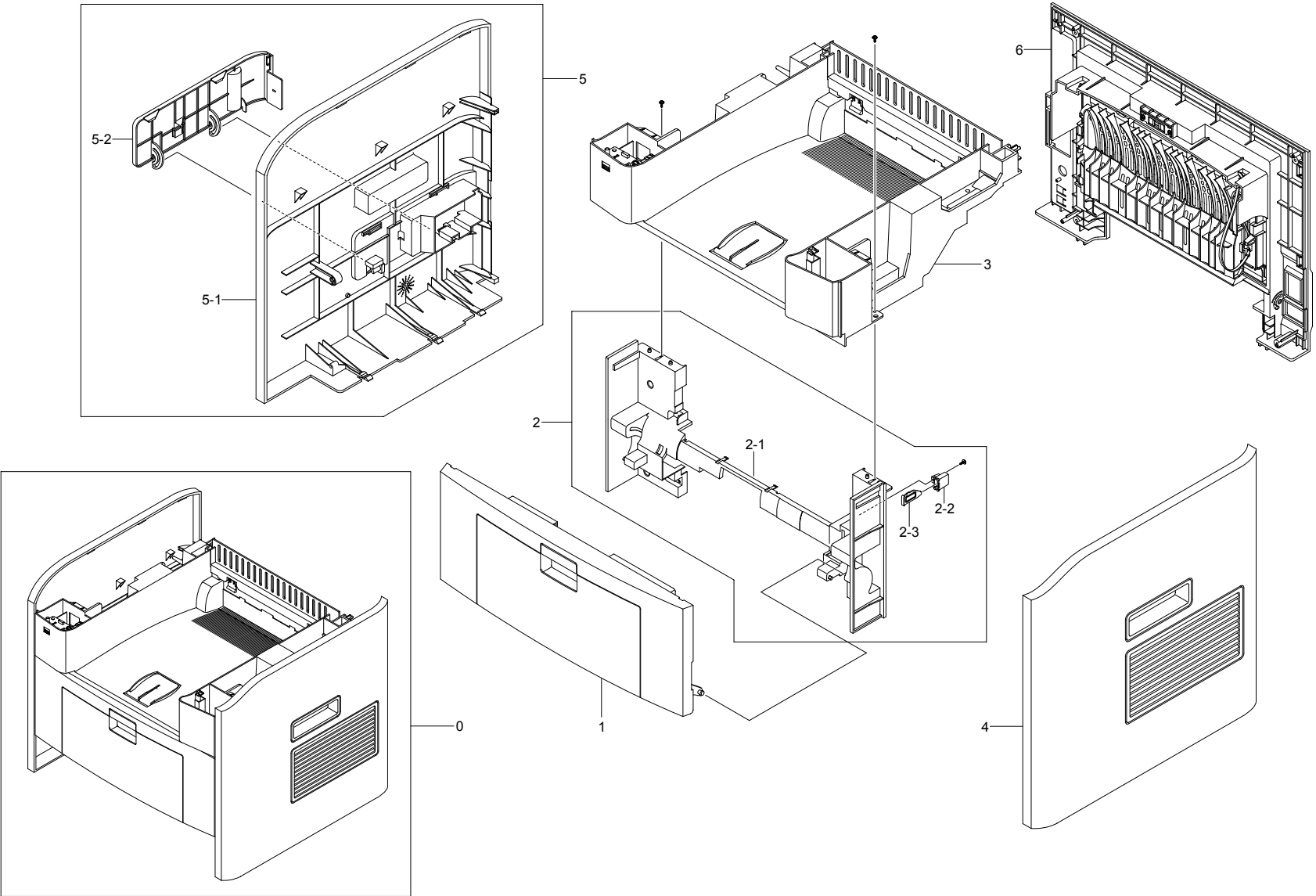

## 8.3 Middle Cover Ass'y

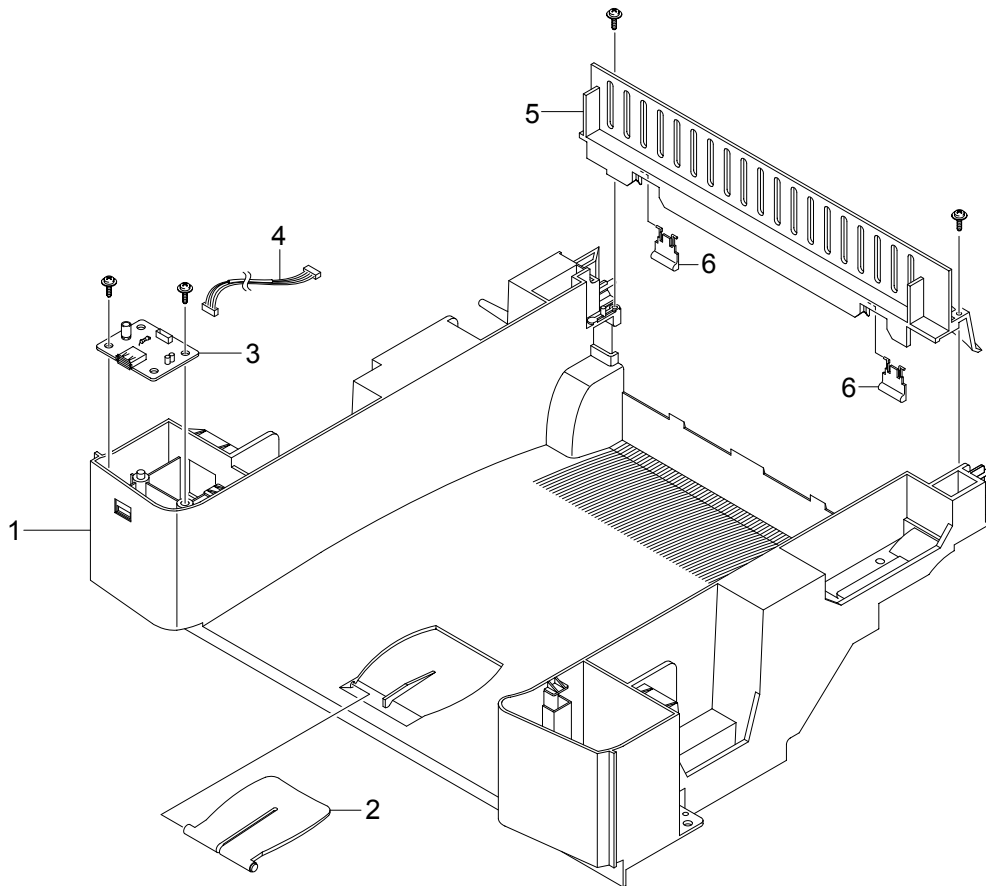
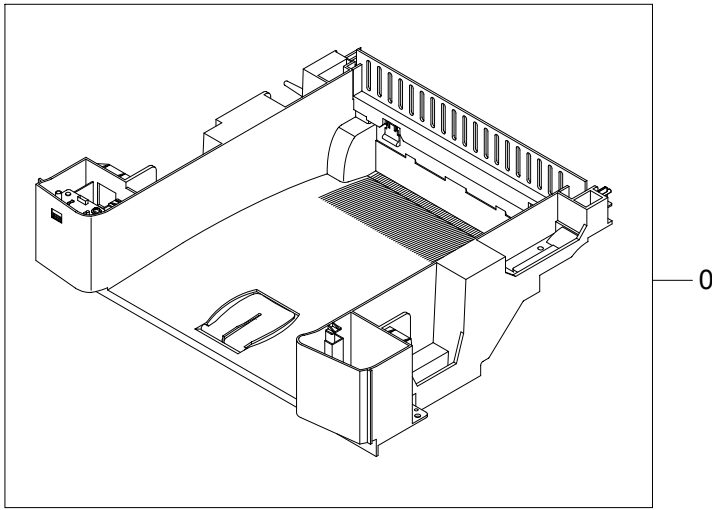

### 8.4 Front Cover Ass'y

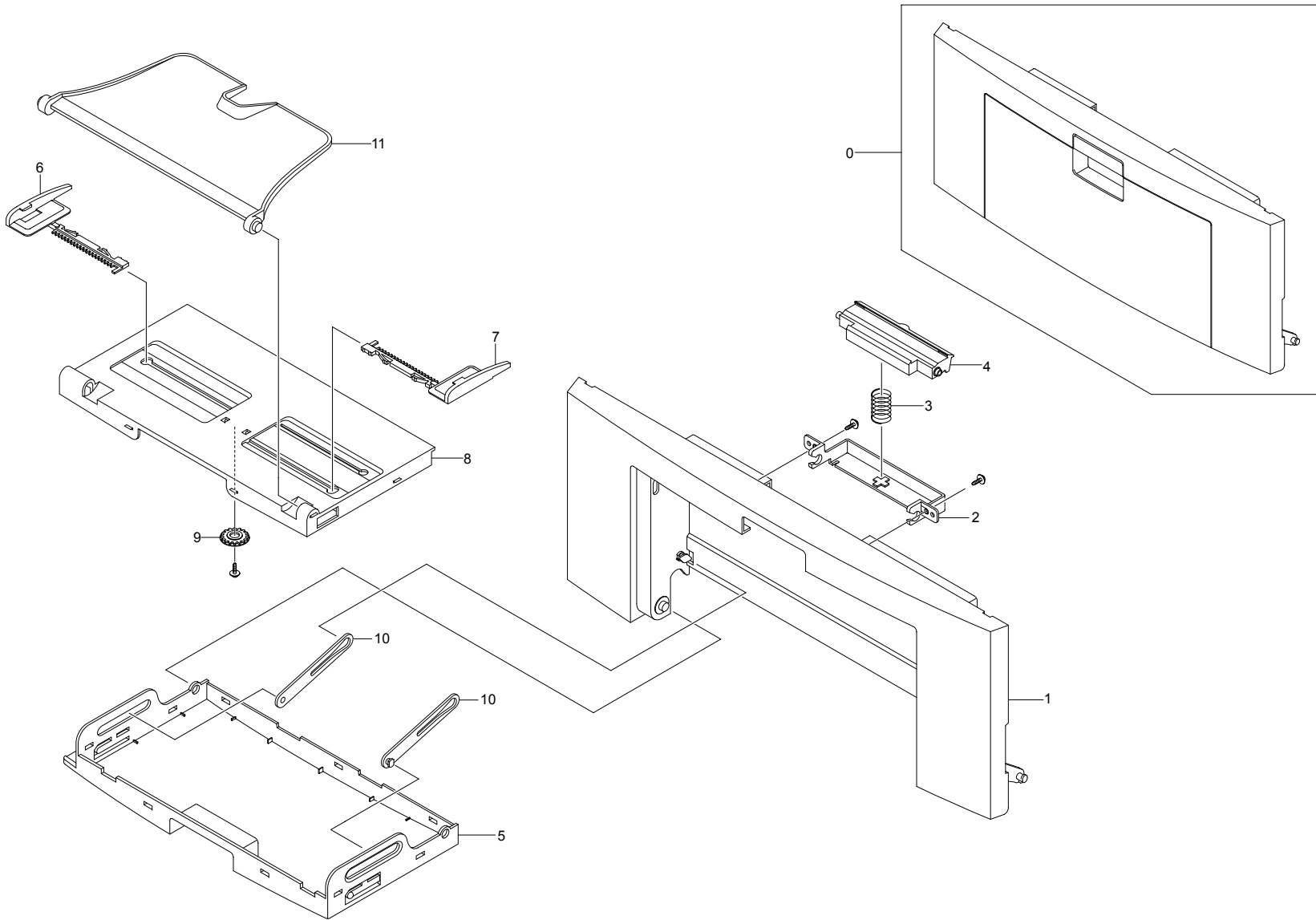



### 8.5 Rear Cover Ass'y

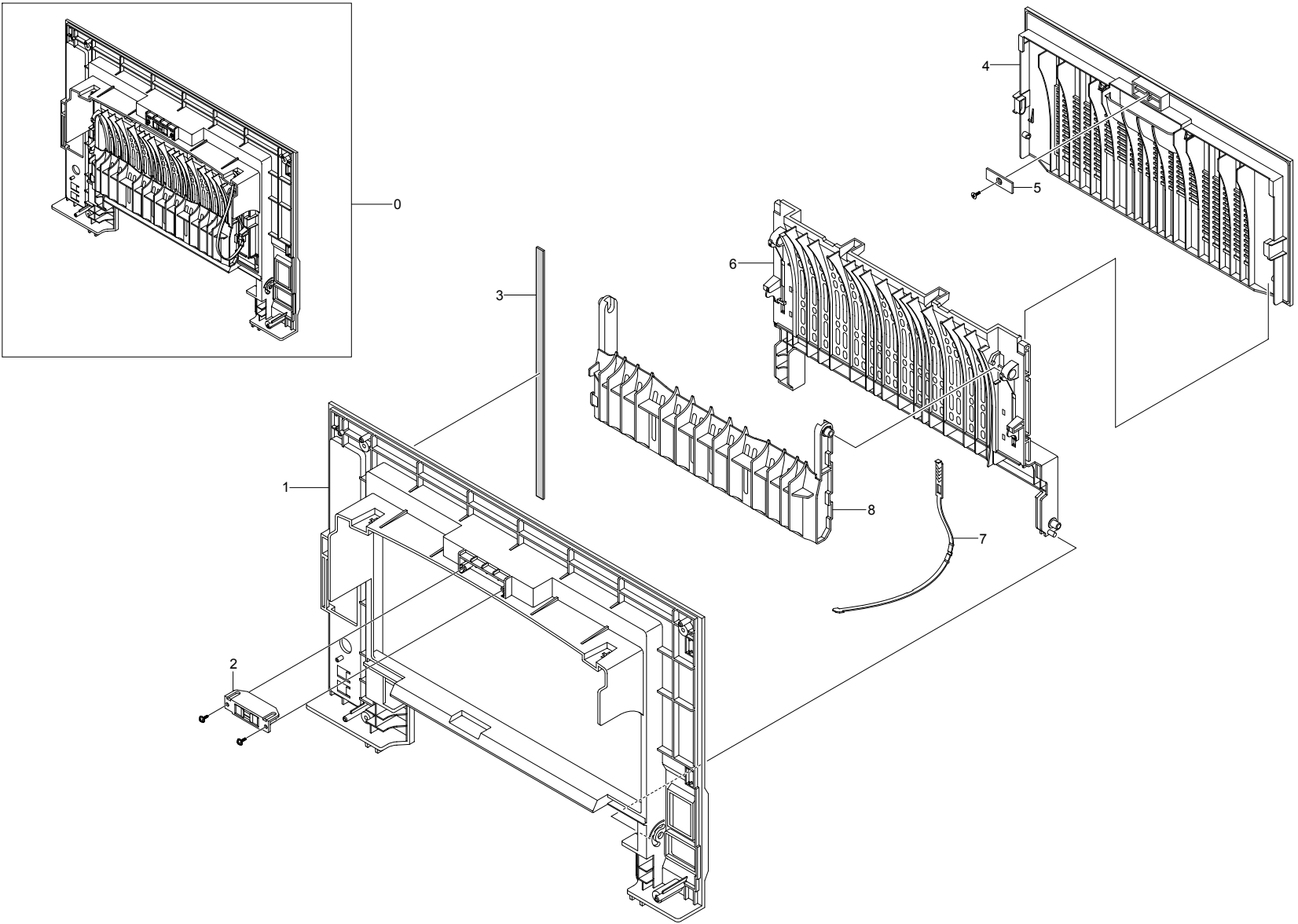

# 8.6 Frame Assembly

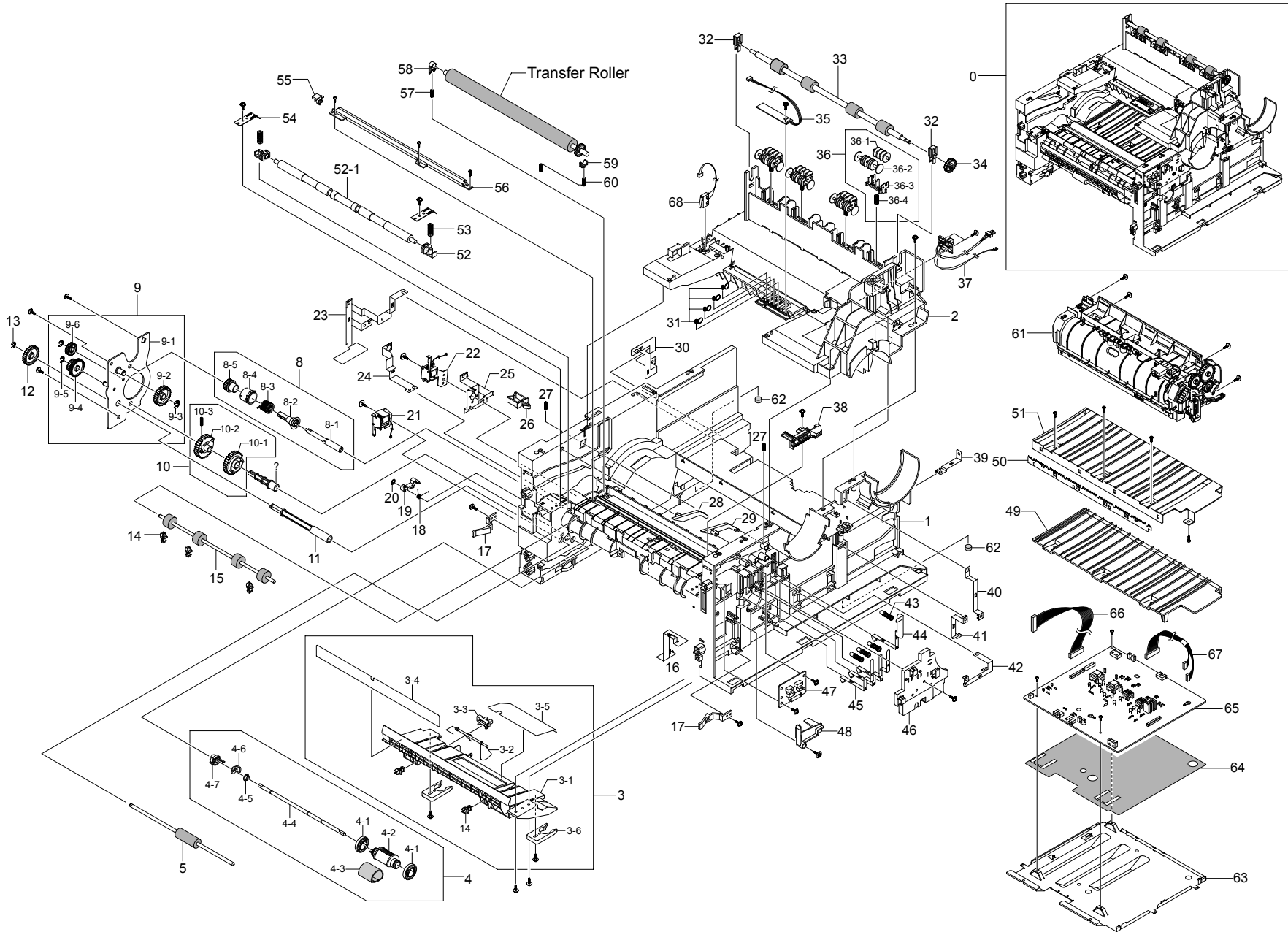

## 8.7 Fuser Drive Ass'y

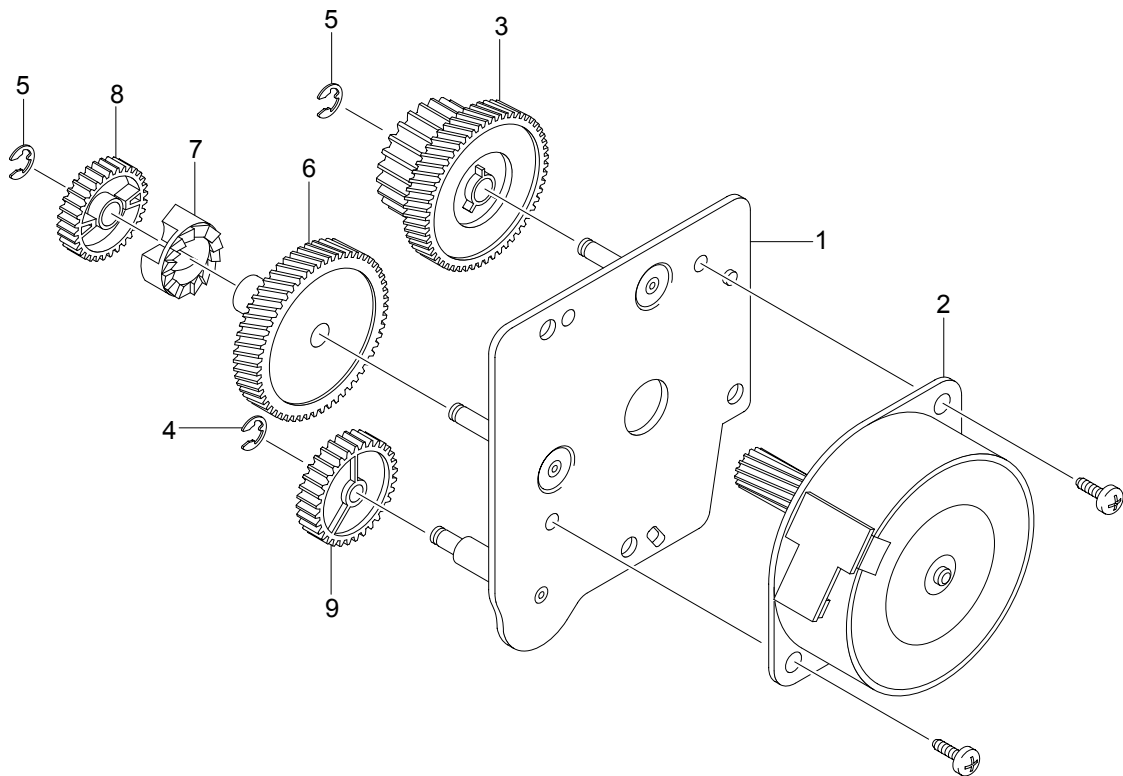
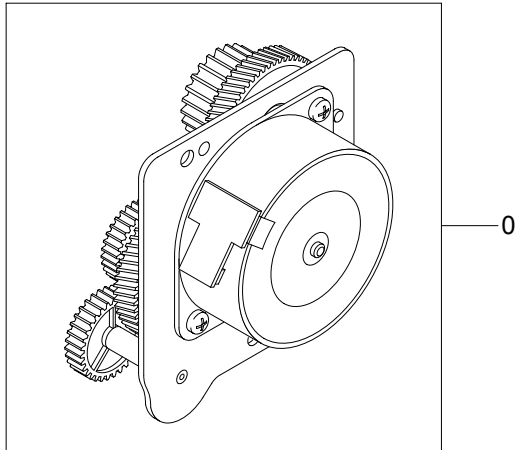

## 8.8 Main Drive Ass'y

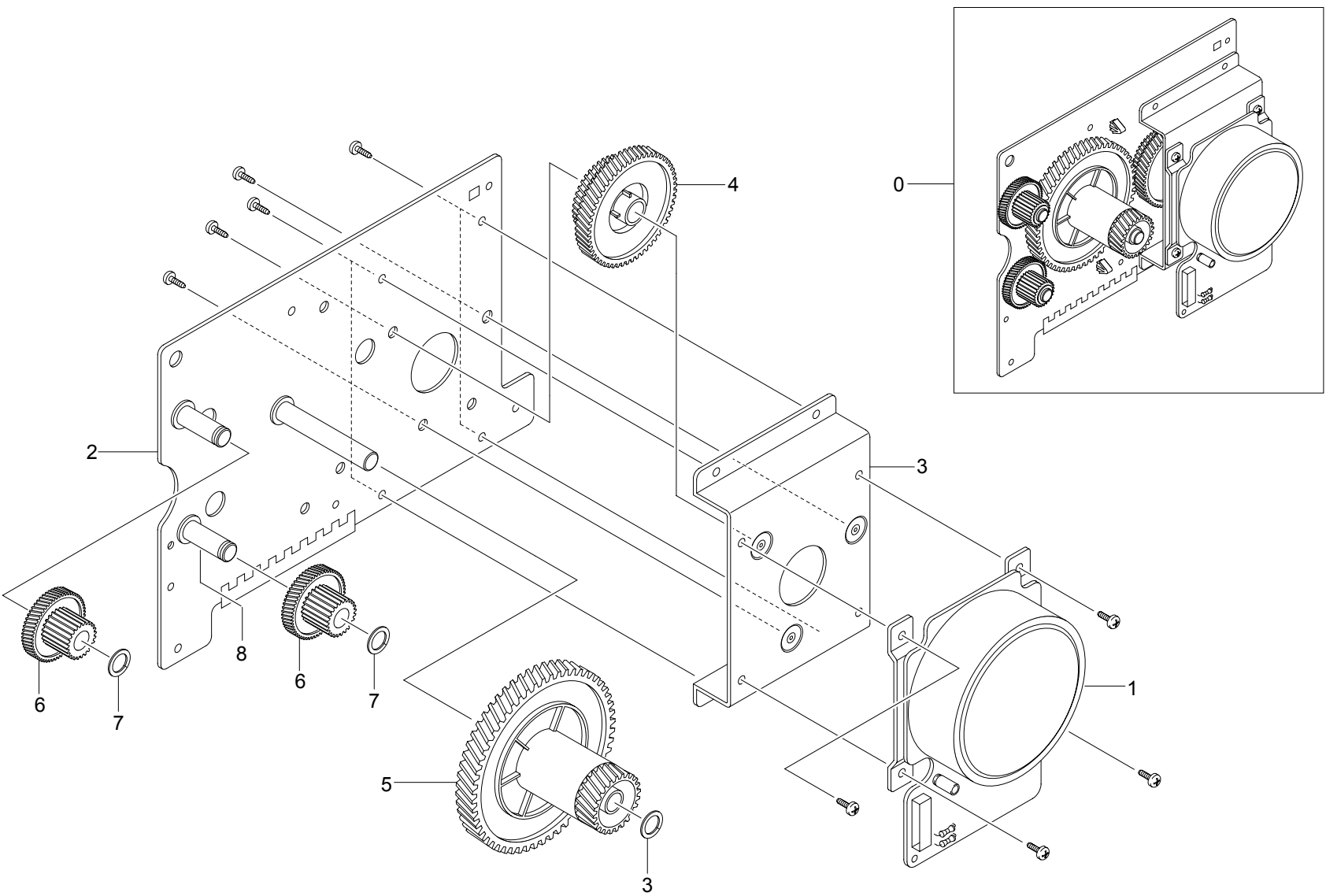

# 8.9 MP Ass'y

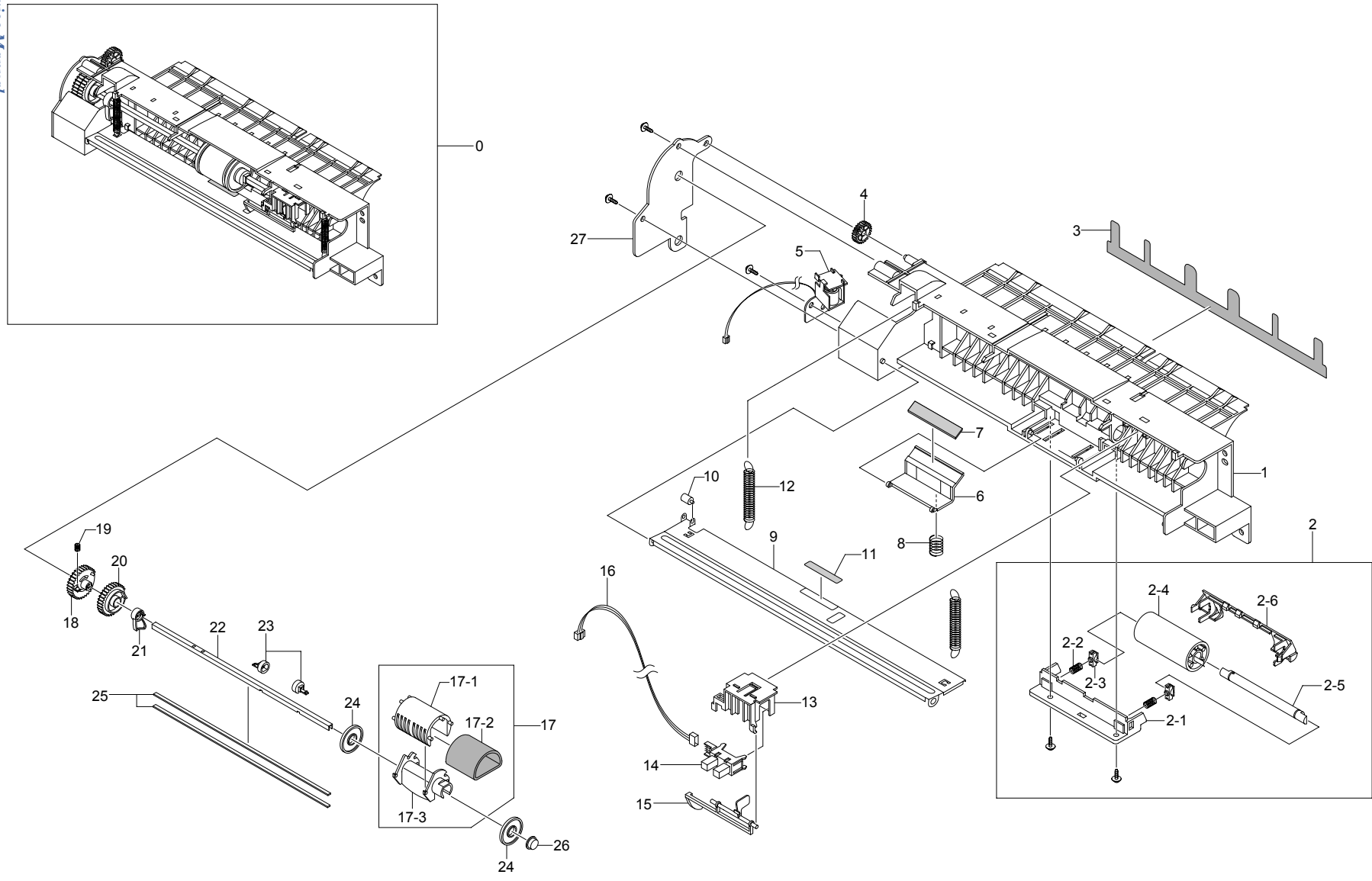

# 8.10 ADF Ass'y

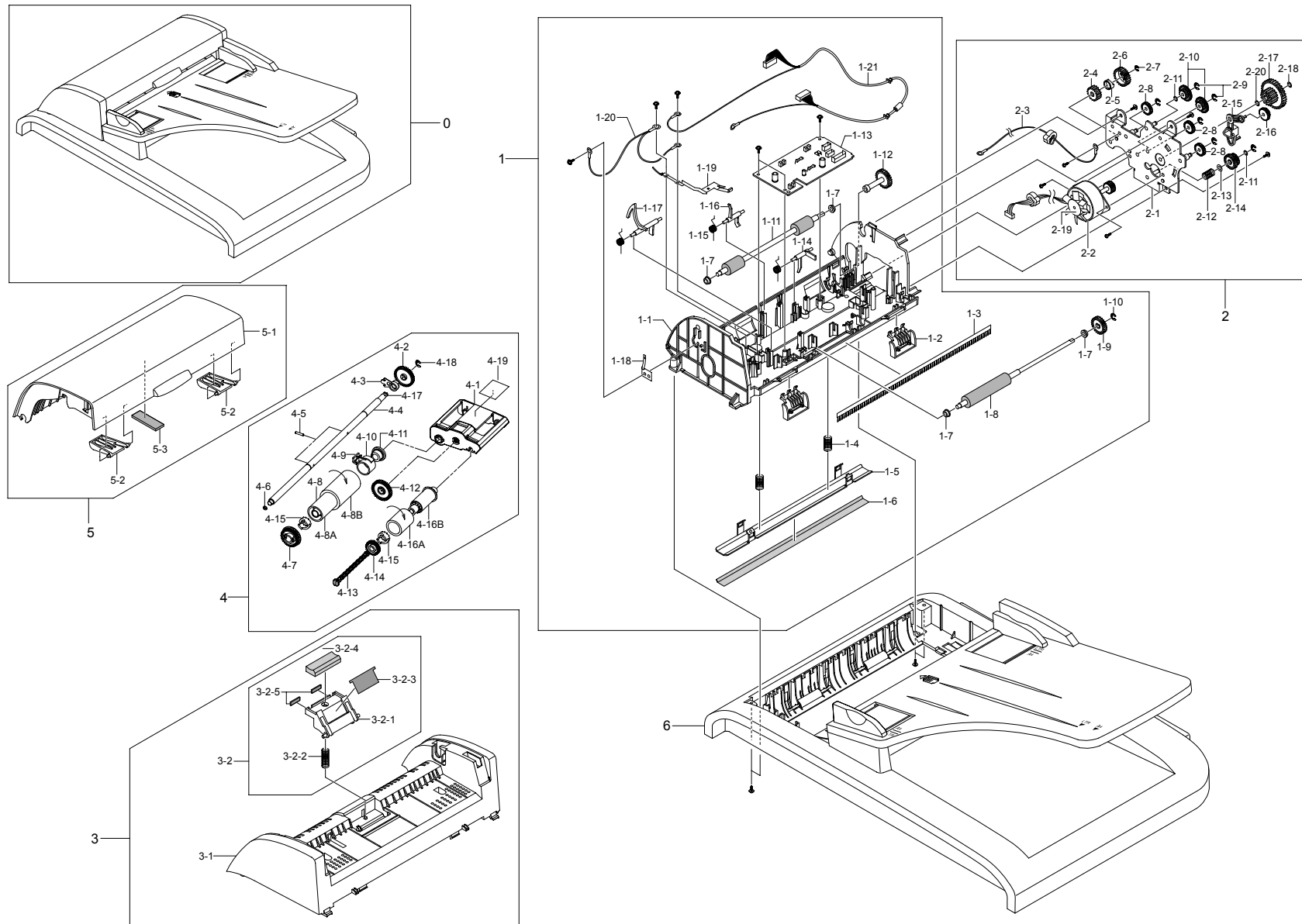

## 8.11 Cover Platen Ass'y

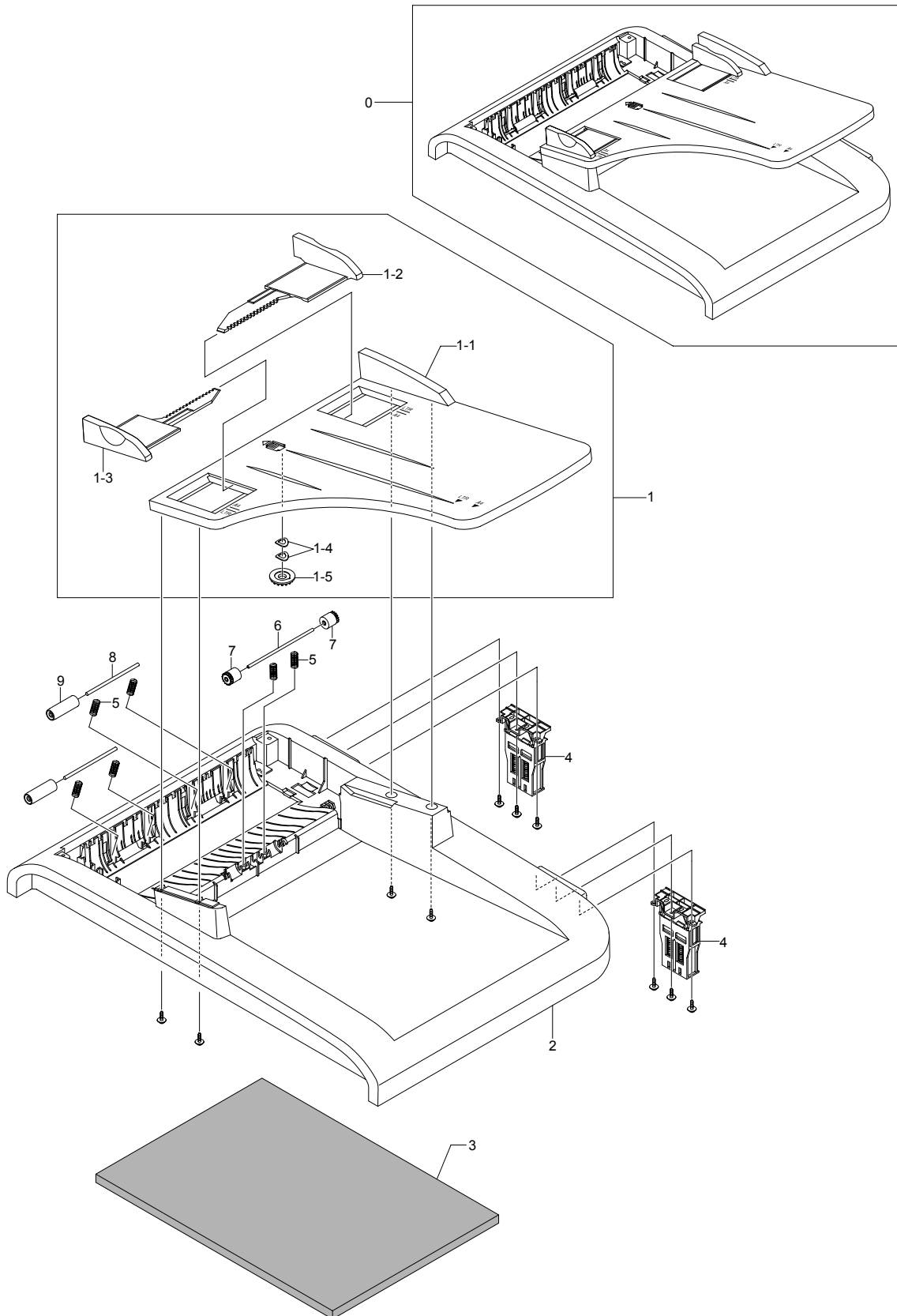

## 8.12 OPE Unit

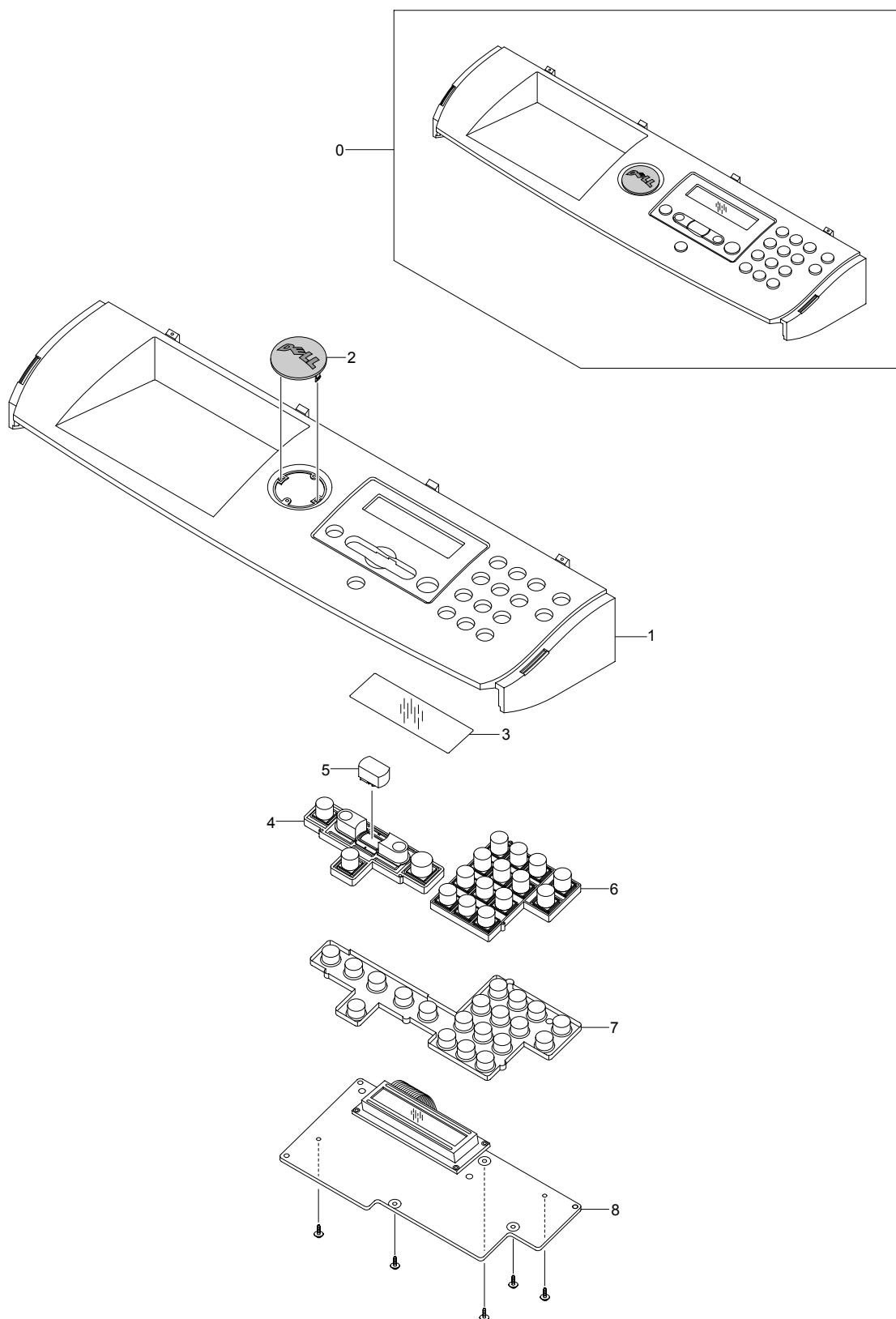



## 8.13 Scanner Ass'y

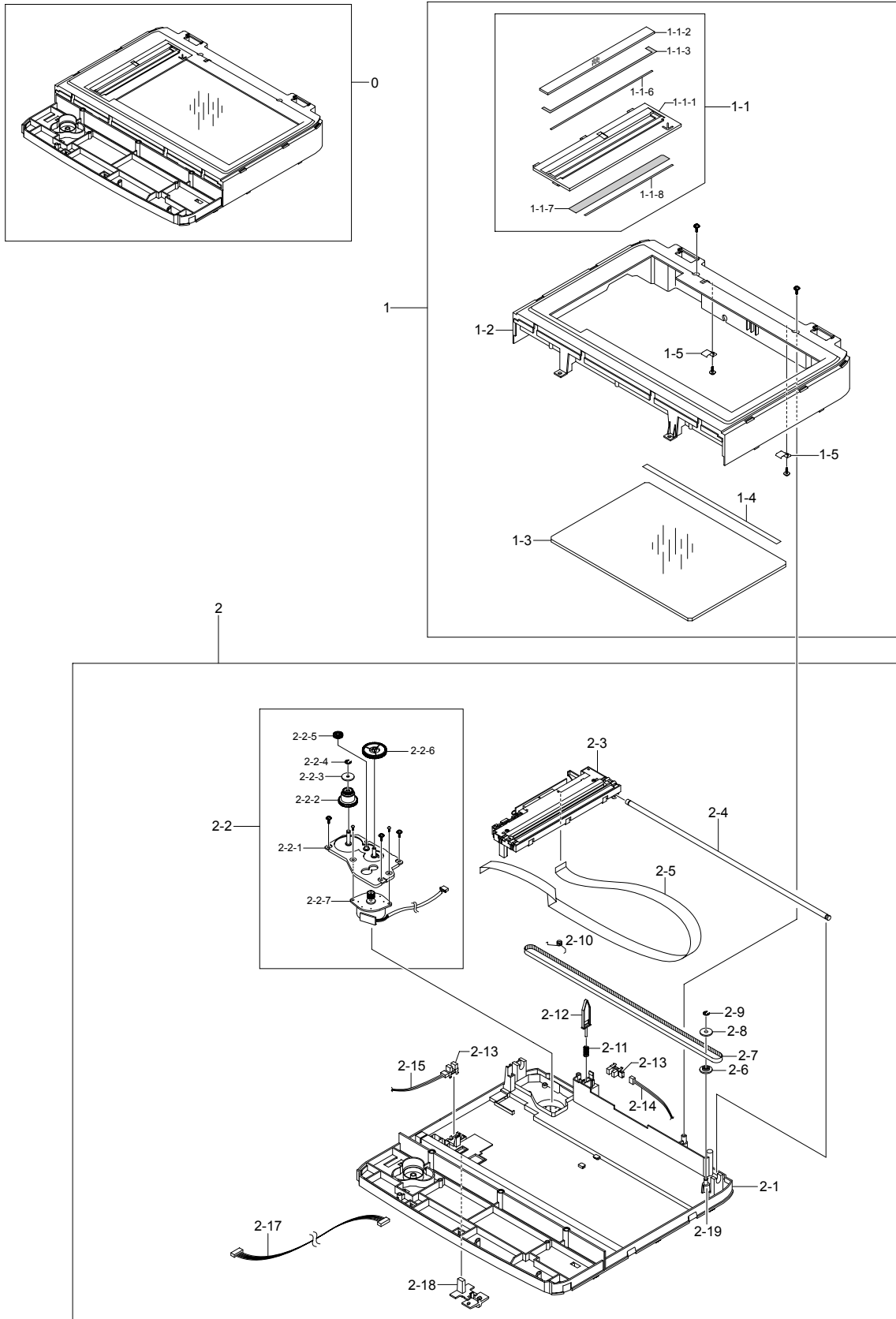

### 8.14 Cassette Ass'y

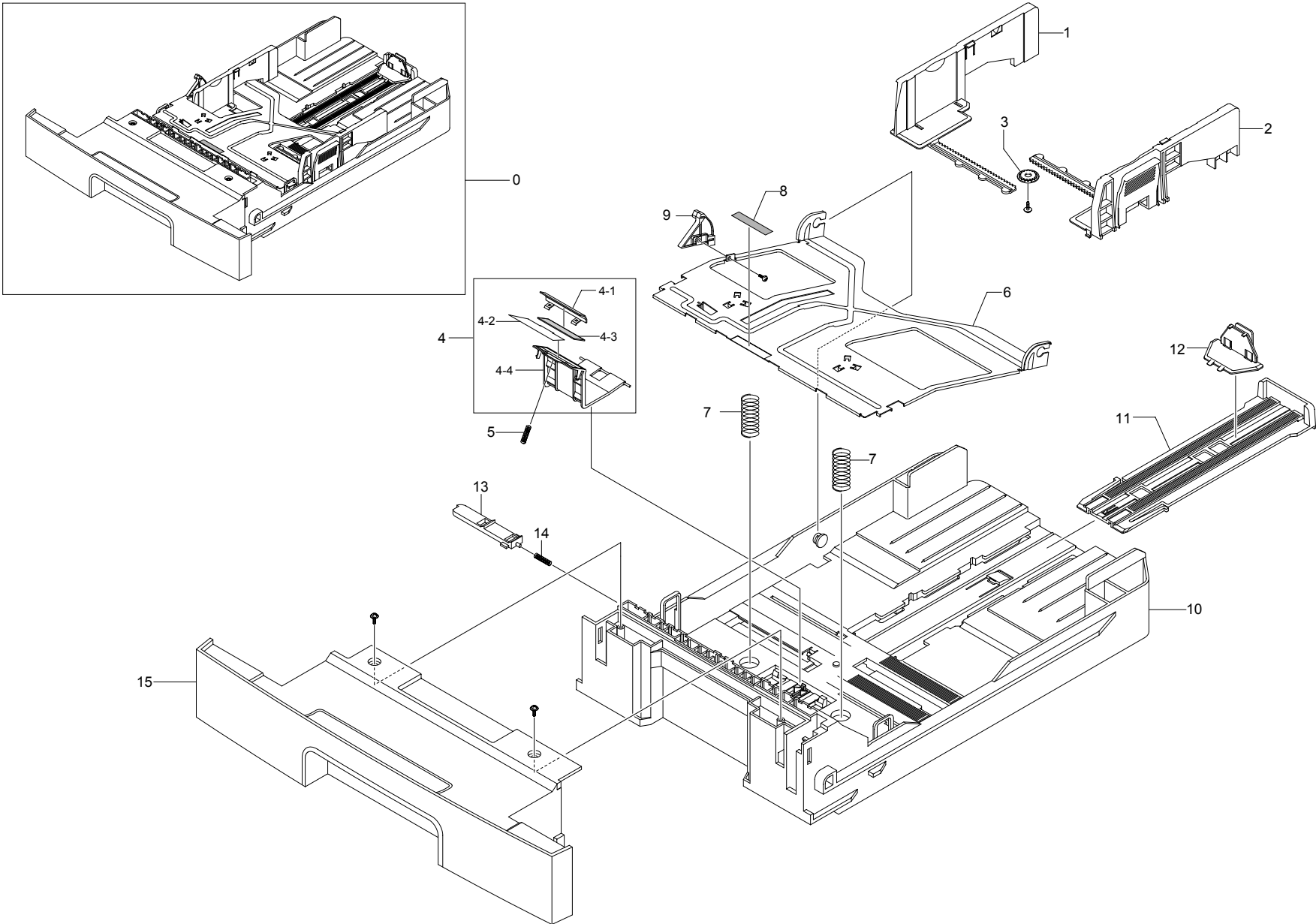

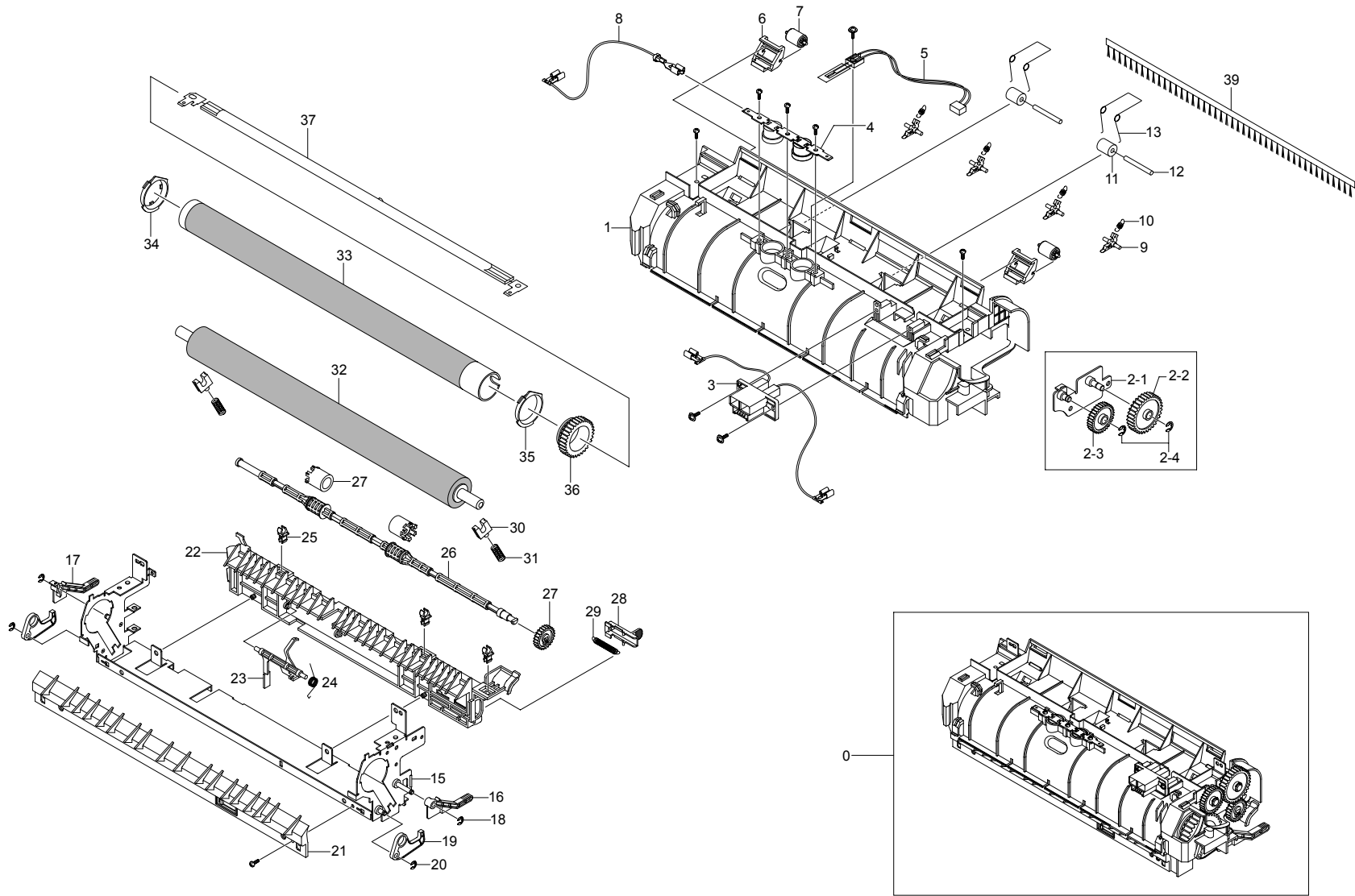

# 8.15 Fuser Ass'y

### 8.16 Duplex Unit(Optional)

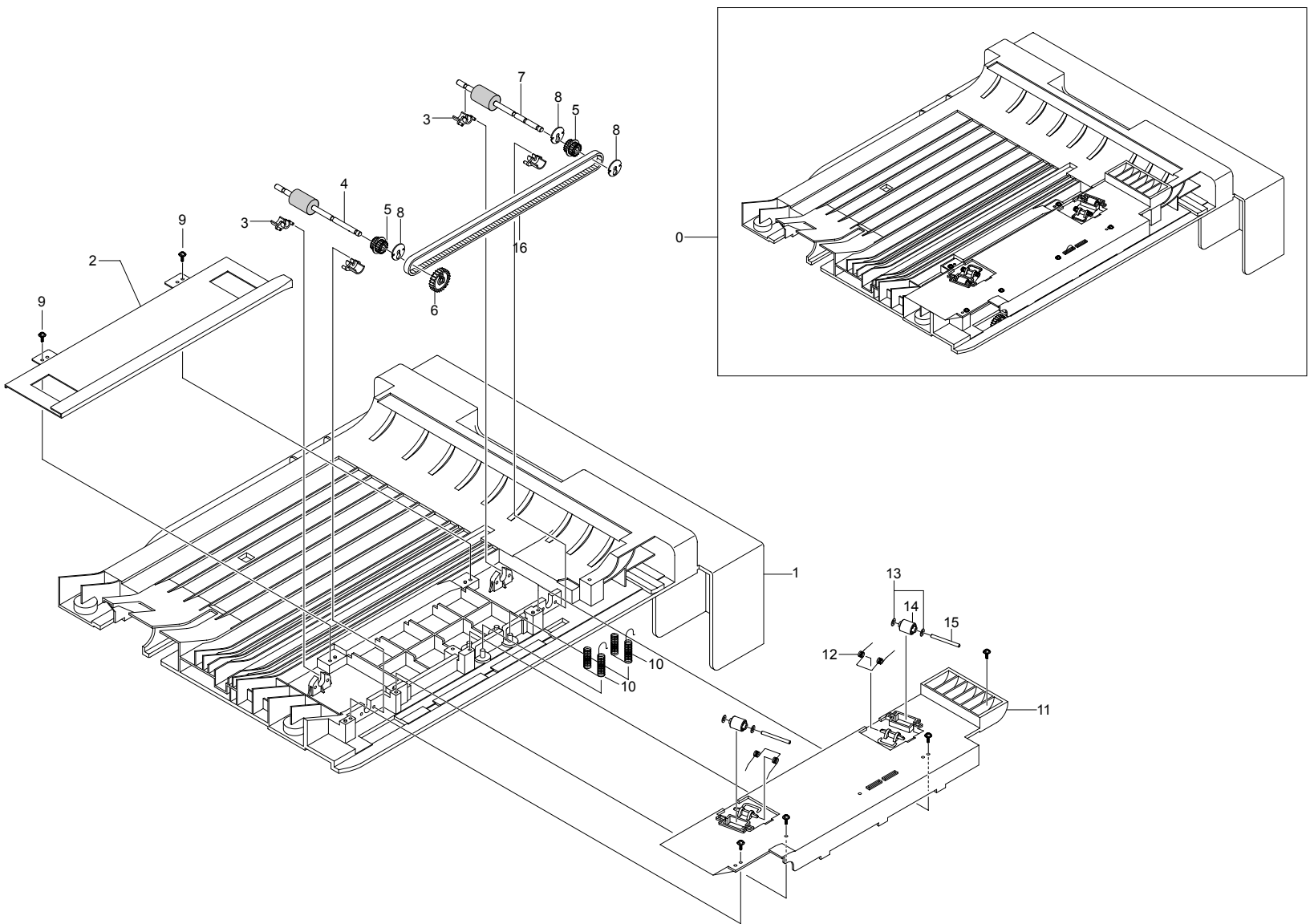

## Parts List(Model: Dell 1815dn)

8.1 Main Exploded Views					
Drawer#	SEC Parts Code	Description and Specification	QT'y	FRU Item (O/X)	Remark
8.1-0	Dell 1815dn	Set	1	X	
8.1-1	JC96-03792A	ELA HOU-FRAME 110V	1	X	110V
8.1-1	JC96-03791A	ELA HOU-FRAME 220V	1	X	220V
8.1-2	JC96-03866A	ELA HOU-FUSER DRIVE	1	X	
8.1-3	JC96-03837A	ELA HOU-MPF	1	O	
8.1-4	JC96-03762A	ELA UNIT-DUPLEX DRIVE	1	O	
8.1-4-1	JC61-01599A	BRACKET-P-GEAR DUP	1	X	
8.1-4-2	JC31-00048A	MOTOR STEP-DUPLEX	1	X	
8.1-4-3	JC66-01159A	GEAR-DUP RDCN 45/19	1	X	
8.1-5	JC39-00526A	CBF HARNESS-DUPLEX	1	X	
8.1-6	JC31-00025A	FAN-DC(Main FAN)	1	O	
8.1-7	JC96-03065A	ELA HOU-ADF MOTOR	1	X	
8.1-8	JC97-02652A	MEA-TRANSFER ROLLER (Drawer# 8.1-8 + 8.1-8-1)	1	O	
8.1-8-1	JC66-00395A	GEAR-TRANSFER	1	X	
8.1-9	JC63-00912B	SHIELD-P-CONTROLLER	1	X	
8.1-10	3001-001293	SPEAKER	1	X	
8.1-11	JC92-01746B	PBA SUB-MODEM	1	O	
8.1-12	JC39-00518A	CBF HARNESS-ENGINE	1	X	
8.1-13	JC92-01744A	PBA MAIN-CONTROLLER	1	O	
8.1-14	JC96-03970A	ELA HOU-MAIN RAM DIMM	1	O	
8.1-15	JC97-02392A	MEA-COVER	1	X	
8.1-16	SCX-D5525A/DEL	TONER CARTRIDGE(3K)	1	O	
8.1-16	SCX-D5525B/DEL	TONER CARTRIDGE(5K)	1	O	
8.1-17	JC97-02414A	MEA UNIT-CASSETTE	1	O	
8.1-23	JC59-00027A	UNIT-LSU	1	O	
8.1-23-1	JC39-00524A	CBF HARNESS-LSU S/W	1	X	
8.1-24	JC96-03778A	ELA HOU-SCAN	1	X	
8.1-25	JC96-03810A	ELA HOU-ADF	1	O	
8.1-26	JC97-02393B	MEA UNIT-DUPLEX	1	X	
8.1-27	JC63-00913A	SHIELD-P-SMPS	1	X	
8.1-28	JC39-00523A	CBF HARNESS-AC INLET	1	X	
8.1-29	JC61-01653B	STOPPER-M STRAP	1	X	
8.1-30	JC63-00960A	SHEET-INSULATOR_SMPS	1	X	
8.1-31	JC44-00097A	SMPS-PSP_TYPE3_V1	1	O	
8.1-31	JC44-00090A	SMPS-PSP_TYPE3_V2C	1	O	
8.1-32	JC72-00382B	PMO-BUSHING FEED	2	X	
8.1-33	3903-000085	CBF-POWER CORD	1	X	
8.2 Cover Ass'y					
Drawer#	SEC Parts Code	Description and Specification	QT'y	FRU Item (O/X)	Remark
8.2-0	JC97-02392A	MEA-COVER	1	X	
8.2-1	JC97-02423A	MEA-COVER FRONT	1	O	
8.2-2	JC97-02424A	MEA-COVER MID FRONT	1	X	
8.2-2-1	JC63-00954A	COVER-M MID FRONT	1	X	
8.2-2-2	JC67-00068B	CAP-M SUB ACTUATOR	1	X	
8.2-2-3	JC72-01339A	PMO-M-SUB ACTUATOR	1	X	
8.2-3	JC63-00949A	COVER-M MIDDLE	1	X	
8.2-4	JC63-00947A	COVER-M SIDE R	1	O	
8.2-5	JC97-02421A	MEA-COVER SIDE L	1	O	
8.2-5-1	JC63-00948A	COVER-M SIDE L	1	X	
8.2-5-2	JC63-00950A	COVER-M DIMM	1	O	
8.2-6	JC97-02422A	MEA-COVER REAR	1	O	
8.3 Middle Cover Ass'y					
Drawer#	SEC Parts Code	Description and Specification	QT'y	FRU Item (O/X)	Remark
8.3-0	JC96-03794A	COVER-M MIDDLE	1	O	
8.3-1	JC63-00954A	COVER-M MID FRONT	1	X	
8.3-2	JC63-00513A	COVER-M-RX STACKER	1	X	
8.3-3	JC92-01636A	PBA SUB-USB HOST	1	O	
8.3-4	JC39-00397A	CBF HARNESS-USB HOST	1	X	
8.3-5	JC63-00938B	COVER-M REAR UPPER	1	X	
8.3-6	JC72-01001A	PMO-SUB STACKER	2	X	
8.4 Front Cover Ass'y					
Drawer#	SEC Parts Code	Description and Specification	QT'y	FRU Item (O/X)	Remark

Drawer#	SEC Parts Code	Description and Specification	QT'y	FRU Item (O/X)	Remark
<b>8.4-0</b>	<b>JC97-02423A</b>	<b>MEA-COVER FRONT</b>	<b>1</b>	<b>O</b>	
8.4-1	JC63-00953A	COVER-M_FRONT	1	X	
8.4-2	JC61-00953C	HOLDER-M_LOCKER	1	X	
8.4-3	JG61-70549A	SPRING ETC-CIS(C2)	1	X	
8.4-4	JC64-00232A	KNOB-M_LOCKER	1	X	
8.4-5	JC63-00946A	TRAY-M_ASF_INPUT	1	X	
8.4-6	JC70-00478C	ADJUST-M_MP L	1	X	
8.4-7	JC70-00479C	ADJUST-M_MP R	1	X	
8.4-8	JC63-00446D	TRAY-ASF_INPUT_UPPER	1	X	
8.4-9	JG66-40003A	GEAR-PINION	1	X	
8.4-10	JC63-00444A	TRAY-M-LINK_MP	2	X	
8.4-11	JC63-00447D	TRAY-ASF_FOLDER	1	X	
<b>8.5 Rear Cover Ass'y</b>					
Drawer#	SEC Parts Code	Description and Specification	QT'y	FRU Item (O/X)	Remark
<b>8.5-0</b>	<b>JC97-02422A</b>	<b>MEA-COVER REAR</b>	<b>1</b>	<b>O</b>	
8.5-1	JC63-00951A	COVER-M_REAR	1	X	
8.5-2	JC61-00961A	MAGNET-CATCH DELL	1	X	
8.5-3	JC63-01028A	SHEET-PORT	1	X	
8.5-4	JC63-00936B	COVER-M_FACE UP	1	X	
8.5-5	JC61-00962A	PLATE-MAGNET CATCH	1	X	
8.5-6	JC63-00937B	COVER-M-STACKER REAR	1	X	
8.5-7	JC61-01653A	STOPPER-M-STRAP	1	X	
8.5-8	JC61-01583A	GUIDE-OUTPUT FUSER	1	X	
<b>8.6 Frame Assembly</b>					
Drawer#	SEC Parts Code	Description and Specification	QT'y	FRU Item (O/X)	Remark
<b>8.6-0</b>	<b>JC96-03792A</b>	<b>ELA HOU-FRAME 110V</b>	<b>1</b>	<b>X</b>	<b>110V</b>
<b>8.6-0</b>	<b>JC96-03791A</b>	<b>ELA HOU-FRAME 220V</b>	<b>1</b>	<b>X</b>	<b>220V</b>
8.6-1	JC61-01620A	FRAME-M_BASE	1	X	
8.6-2	JC61-01621A	FRAME-M_EXIT	1	X	
8.6-3	JC96-03829A	ELA HOU-GUIDE DUP F	1	X	
8.6-3-1	JC61-01600A	GUIDE-M_FRONT DUPLEX	1	X	
8.6-3-2	JC66-01187A	LEVER-ACTUATOR EMPTY	1	X	
8.6-3-3	0604-001095	PHOTO-INTERRUPTER	1	X	
8.6-3-4	JC63-01095A	SHEET-GUIDE DUP_OUT	1	X	
8.6-3-5	JC63-00992A	SHEET-GUIDE FRONT DU	1	X	
8.6-3-6	JC66-01170A	CAM-SHAFT PICK UP	1	X	
8.6-4	JC97-02441A	MEA-ROLLER PICK UP	1	O	
8.6-4-1	JC66-01169A	ROLLER-IDLE PICK UP	2	X	
8.6-4-2	JC61-01601A	HOUSING-M_PICK UP	1	X	
8.6-4-3	JC66-01168A	ROLLER-PICK UP	1	X	
8.6-4-4	JC66-01171A	SHAFT-PICK UP	1	X	
8.6-4-5	JC72-41364A	PMO-BUSHING P/U,MP	1	X	
8.6-4-6	JC66-00050A	CAM-CATCH	1	X	
8.6-5	JC66-01173A	ROLLER-FEED	1	X	
8.6-8	JC97-01788A	MEA UNIT-CLUTCH	1	X	
8.6-8-1	JC66-00398A	SHAFT-FEED	1	X	
8.6-8-2	JC72-00981A	PMO-HUB CLUTCH	1	X	
8.6-8-3	6107-001171	SPRING-TS	1	X	
8.6-8-4	JC72-00978A	PMO-COLLAR_SPRING	1	X	
8.6-8-5	JC66-00393A	GEAR-FEED 1	1	X	
8.6-9	JC97-02394A	MEA UNIT-BRACKET FEED	1	X	
8.6-9-1	JC61-01582A	BRACKET-P-FEED	1	X	
8.6-9-2	JC66-01166A	GEAR-IDLE Z29 HELICAL	1	X	
8.6-9-3	6044-000231	RING-E	1	X	
8.6-9-4	JC66-01164A	GEAR-RETARD 39/19	1	X	
8.6-9-5	JC66-00484A	GEAR-T2 IDEL_Z27	1	X	
8.6-9-6	6044-000125	RING-E	2	X	
8.6-10	JC97-02648A	MEA UNIT-GEAR PICK UP	1	X	
8.6-10-1	JC66-01183A	GEAR-PICK UP INNER	1	X	
8.6-10-2	JC66-01184A	GEAR-PICK UP_OUTER	1	X	
8.6-10-3	6107-001167	SPRING-CS	1	X	
8.6-11	JC66-01160A	SHAFT-M_FEED2	1	X	
8.6-12	JC66-01165A	GEAR-FEED2 Z27	1	X	
8.6-13	6044-000125	RING-E	1	X	
8.6-14	JC72-00382B	PMO-BUSHING FEED	3	X	
8.6-15	JC66-00526A	ROLLER-FEED ROLLER 1	1	X	
8.6-17	JC72-00983A	PMO-LOCKER CST	2	X	
8.6-18	6107-001170	SPRING-TS	1	X	
8.6-19	JC66-00377A	CAM-M-PICK_UP	1	X	
8.6-20	6044-000001	RING-CS	1	X	

Drawer#	SEC Parts Code	Description and Specification	QT'y	FRU Item (O/X)	Remark
8.6-21	JC33-00010A	SOLENOID-HB (MANUAL)	1	X	
8.6-22	JC33-00014A	SOLENOID-FEED ROCKY2	1	X	
8.6-23	JC63-00917A	GROUND-P-DRIVE	1	X	
8.6-24	JC63-00923A	GROUND-P-PUSH BUSHING	1	X	
8.6-25	JC63-00922A	GROUND-P-DRIVE2	1	X	
8.6-26	6502-001093	CABLE CLAMP	1	X	
8.6-27	JC61-70932A	SPRING ETC-GUIDE DEVE	2	X	
8.6-28	JC72-00984A	PMO-PLATE GUIDE DEVE_L	1	X	
8.6-29	JC72-00985A	PMO-PLATE GUIDE DEVE_R	1	X	
8.6-30	JC63-00926A	GROUND-P-SHIELD	1	X	
8.6-31	JC65-00019A	TERMINAL-P_CRUM	4	X	
8.6-32	JC61-00829A	HOLDER-BEARING EXIT F/DOWN	2	X	
8.6-33	JC97-01034A	MEA RACK-EXIT ROLLER	1	X	
8.6-34	JC66-01196A	ROLLER-EXIT F/DOWN	1	X	
8.6-35	JC92-01829A	PBA SUB-TERMINAL	1	X	
8.6-36	JC97-01034A	MEA RACK-EXIT ROLLER	4	X	
8.6-36-1	JC72-41008A	PMO-ROLLER FD R	1	X	
8.6-36-2	JC72-41007A	PMO-ROLLER FD F	1	X	
8.6-36-3	JC72-41006A	PMO-HOLDER EXIT ROLL	1	X	
8.6-36-4	JC61-70911A	SPRING ETC-EXIT ROLL FD	1	X	
8.6-37	JC39-00523A	CBF HARNESS-AC INLET	1	X	
8.6-39	JC63-00920A	GROUND-P-FUSER	1	X	
8.6-40	JC63-00925A	GROUND-P-MOTOR FUSER	1	X	
8.6-41	JC63-00924A	GROUND-P-SHIELD SMPS	1	X	
8.6-42	JC63-00921A	GROUND-P-GUIDE TR	1	X	
8.6-43	JC75-00049A	MEC-TERMINAL	4	X	
8.6-43-1	JC61-00035A	SPRING ETC-HV APOLLO	1	X	
8.6-43-2	JC70-00050A	IPR-TERMINAL	1	X	
8.6-44	JC65-00014A	TERMINAL-P-HV CR	1	X	
8.6-45	JC70-00312A	IPR-P-TERMINAL CON	3	X	
8.6-46	JC61-01584A	HOUSING-M_TERMINAL	1	X	
8.6-47	JC92-01828A	PBA SUB-CONNECTION	1	X	
8.6-48	JC72-00974A	PMO-ACTUATOR CVR OPEN	1	X	
8.6-49	JC61-01746A	GUIDE-TR RIB	1	X	
8.6-50	JC61-00604B	PLATE-E_SAW	1	X	
8.6-51	JC61-00607A	GUIDE-P-TR	1	X	
8.6-53	JC61-70958A	SPRING ETC-TR	2	X	
8.6-54	JC61-00914A	PLATE-P-PUSH BUSHING	2	X	
8.6-55	JC61-00907A	HOLDER-M-PTL R2	1	X	
8.6-56	JC70-00307A	IPR-P-EARTH TRANSFER	1	X	
8.6-57	JC61-00047A	SPRING ETC-TR L HAWK	1	X	
8.6-58	JC61-00588A	BUSH-M-TR L	1	X	
8.6-59	JC72-00102A	PMO-BUSHING_TR(L)	1	X	
8.6-60	JC63-00918A	GROUND-P-EARTH TR	1	X	
8.6-61	JC96-03801A	ELA UNIT-FUSER_110V	1	O	110V
8.6-61	JC96-03802A	ELA UNIT-FUSER_220V	1	O	220V
8.6-62	JC61-00835A	FOOT-BACK	2	X	
8.6-63	JC63-00914A	SHIELD-P-HVPS	1	X	
8.6-64	JC63-00961A	SHEET-INSULATOR_HVPS	1	X	
8.6-65	JC44-00107A	HVPS-ELBERT	1	O	
8.6-66	JC39-00519A	CBF HARNESS-SMPS	1	O	
8.6-67	JC39-00518A	CBF HARNESS-ENGINE	1	O	
8.6-68	JC39-00524A	CBF HARNESS-LSU S/W	1	O	

**8.7 Fuser Drive Ass'y**

Drawer#	SEC Parts Code	Description and Specification	QT'y	FRU Item (O/X)	Remark
8.7-0	JC96-03866A	ELA HOU-FUSER DRIVE	1	X	
8.7-1	JC61-01598A	BRACKET-P-FUSER EXIT	1	X	
8.7-2	JC31-00037E	MOTOR STEP-MAIN	1	X	
8.7-4	6044-000125	RING-E	1	X	
8.7-5	6044-000231	RING-E	2	X	
8.7-6	JC66-01163A	GEAR-FUSER RDCN IN 95	1	X	
8.7-7	JC66-00340A	GEAR-HUB CLUTCH	1	X	
8.7-8	JC66-00417A	GEAR-RDCN FUSER OUT	1	X	
8.7-9	JC66-01158A	GEAR-EXIT RDCN 87/24	1	X	

**8.8 Main Drive Ass'y**

Drawer#	SEC Parts Code	Description and Specification	QT'y	FRU Item (O/X)	Remark
8.8-0	JC96-03761A	ELA UNIT-MAIN DRIVE	1	O	
8.8-1	JC31-00047A	MOTOR DC-BLDC MAIN	1	X	
8.8-2	JC61-01593A	BRACKET-P-GEAR MAIN	1	X	
8.8-3	JC61-01597A	BRACKET-P-MOTOR MAIN	1	X	

Drawer#	SEC Parts Code	Description and Specification	QT'y	FRU Item (O/X)	Remark
8.8-4	JC66-01156A	GEAR-OPC RDCN 93/61	1	X	
8.8-5	JC66-01157A	GEAR-OPC DRV 113/33	1	X	
8.8-6	JC66-01162A	GEAR-FEED RDCN 55/18	2	X	
8.8-7	6031-000023	WASHER-PLAIN	2	X	
8.8-8	6302-001056	GASKET	3	X	

**8.9 MP Ass'y**

Drawer#	SEC Parts Code	Description and Specification	QT'y	FRU Item (O/X)	Remark
<b>8.9-0</b>	<b>JC96-03837A</b>	<b>ELA HOU-MPF</b>	<b>1</b>	<b>O</b>	
8.9-1	JC61-01603A	FRAME-M_MP	1	X	
8.9-2	JC97-02443A	MEA-IDLE FEED	1	X	
8.9-2-1	JC61-01604A	HOLDER-M_IDLE FEED	1	X	
8.9-2-2	JC61-00484A	SPRING ETC-EXIT LOWER IDLE	2	X	
8.9-2-3	JC61-01605A	HOLDER-M_SHAFT IDLE	2	X	
8.9-2-4	JC66-01186A	ROLLER-IDLE FEED	1	X	
8.9-2-5	JC66-01172A	SHAFT-IDLE FEED	1	X	
8.9-2-6	JC63-00997A	COVER-M_IDLE FEED	1	X	
8.9-3	JC63-01094A	SHEET-GUIDE MP	1	X	
8.9-4	JC66-00396A	GEAR-IDLE 23	1	X	
8.9-5	JC33-00015A	SOLENOID-MP	1	X	
8.9-6	JC61-00924A	HOLDER-M-PAD_MP	1	X	
8.9-7	JC73-00140A	RPR-FRICTION PAD	1	X	
8.9-8	JC61-70911A	SPRING ETC-EXIT ROLL FD	1	X	
8.9-9	JC61-00927A	PLATE-P-KNOCK UP_MP	1	X	
8.9-10	JC72-00761A	PMO-ROLLER CAM.MP	1	X	
8.9-11	JC73-00141A	RPR-PAD CASSETTE	1	X	
8.9-12	6107-001237	SPRING-ES	2	X	
8.9-13	JC61-00926A	HOLDER-M-SENSOR_MP	1	X	
8.9-14	0604-001095	PHOTO-INTERRUPTER	1	X	
8.9-15	JC72-01338A	PMO-M-ACT EMPTY MP	1	X	
8.9-16	JC39-00365A	CBF HARNESS-MPF SEN	1	X	
8.9-17	JC97-02034A	MEA-PICK UP_MP	1	O	
8.9-17-1	JC73-00194A	RUBBER-PICK UP_MP	1	X	
8.9-17-2	JC61-00925A	HOUSING-M_PICK UP_MP	1	X	
8.9-17-3	JC61-00910A	HOUSING-M-PICK UP2_R2	1	X	
8.9-18	JC66-00710A	GEAR-M-PICK UP_MP	1	X	
8.9-19	6107-001167	SPRING-CS	1	X	
8.9-20	JC66-00709A	GEAR-M-HOLDER_MP	1	X	
8.9-21	JC66-01205A	CAM-M_PICK UP_MP	1	X	
8.9-22	JC66-00399A	SHAFT-P-PICK_UP	1	X	
8.9-23	JC61-00915A	STOPPER-M-PICK UP_R2	2	X	
8.9-24	JC72-00982A	PMO-IDLE PICK_UP	2	X	
8.9-25	JC66-00720A	SHAFT-P-CORE	2	X	
8.9-26	JC61-00587A	BUSH-M-PICK_UP R	1	X	
8.9-27	JC61-00932A	BRACKET-P-PICKUP_MP	1	X	

**8.10 ADF Ass'y**

Drawer#	SEC Parts Code	Description and Specification	QT'y	FRU Item (O/X)	Remark
<b>8.10-0</b>	<b>JC96-03810A</b>	<b>ELA HOU-ADF</b>	<b>1</b>	<b>O</b>	
8.10-1	JC96-03812A	ELA HOU-ADF LOWER	1	X	
8.10-1-1	JC63-00370A	COVER-M-ADF LOWER R2	1	X	
8.10-1-2	JC61-00712A	GUIDE-STACKER SUB	2	X	
8.10-1-3	JC75-00095A	MEC-BRUSH ANTISTATIC	1	X	
8.10-1-4	JC61-00548A	SPRING ETC-WHITE BAR	2	X	
8.10-1-5	JC61-01695A	BRACKET-P_WHITE_BAR	1	X	
8.10-1-6	JC72-00752A	PPR-WHITE BAR SHEET	1	X	
8.10-1-7	JB72-00819A	PMO-BUSH	4	X	
8.10-1-8	JC66-00559A	ROLLER-EXIT	1	X	
8.10-1-9	JC66-00310A	GEAR-AGITATOR-2	1	X	
8.10-1-10	6044-000159	RING-C	1	X	
8.10-1-11	JC66-00560A	ROLLER-DRIVE	1	X	
8.10-1-12	JC66-00460A	SHAFT-M-FEED GEAR 38	1	X	
8.10-1-13	JC92-01755B	PBA SUB-ADF	1	X	
8.10-1-14	JC72-01011A	PMO-ACTUATOR SCAN SENSOR	1	X	
8.10-1-15	JB61-00076A	SPRING ETC-TORSION DOC (CC2-F)	3	X	
8.10-1-16	JC72-01010A	PMO-ACTUATOR REGI SENSOR	1	X	
8.10-1-17	JC72-01320A	PMO-ACT EMPTY ADF	1	X	
8.10-1-18	JC70-10467A	IPR-GROUND_ROLLER	1	X	
8.10-1-19	JC63-00372A	GROUND-P-ADF R2	1	X	
8.10-1-20	JC39-00187A	CBF HARNESS-ADF ROLLER GND	1	X	
8.10-1-21	JC39-00349A	CBF HARNESS-ADF	1	X	
8.10-2	JC96-03065A	ELA HOU-ADF MOTOR	1	X	



Drawer#	SEC Parts Code	Description and Specification	QT'y	FRU Item (O/X)	Remark
8.10-2-1	JC61-00892A	BRACKET-P-GEAR ADF	1	X	
8.10-2-2	JC31-00036A	MOTOR STEP-ADF	1	X	
8.10-2-3	JC39-00363A	CBF HARNESS-ADF GND	1	X	
8.10-2-4	JB66-00101A	GEAR-CLUTCH 29	1	X	
8.10-2-5	JB72-00844A	PMO-WHITE CLUTCH SUB 29	1	X	
8.10-2-6	JC66-00322A	GEAR-CLUTCH 39	1	X	
8.10-2-7	6044-000159	RING-C	1	X	
8.10-2-8	JC66-00458A	GEAR-IDLE 35 ADF	3	X	
8.10-2-9	6044-000125	RING-E	6	X	
8.10-2-10	JC66-00456A	GEAR-40/21 ADF	2	X	
8.10-2-11	6031-000019	WASHER-PLAIN	2	X	
8.10-2-12	JC61-00387A	SPRING ETC-PAD	1	X	
8.10-2-13	6031-001511	WASHER-PLAIN	1	X	
8.10-2-14	JC66-00557B	GEAR-REMOVE ADF(XRX)	1	X	
8.10-2-15	JC66-00454A	LINK-M-SWING ADF	1	X	
8.10-2-16	JC66-00457A	GEAR-SWING 31/20 ADF	1	X	
8.10-2-17	JC66-00455A	GEAR-58/25 ADF	1	X	
8.10-2-18	6031-000023	WASHER-PLAIN	1	X	
8.10-2-19	JC66-00556A	IMPELLER-ADF	1	X	
8.10-3	JC97-01939A	MEA UNIT-ADF UPPER	1	X	
8.10-3-1	JC63-00375A	COVER-M-ADF UPPER R2	1	X	
8.10-3-2	JC97-01940A	MEA UNIT-HOLDER ADF	1	X	
8.10-3-2-1	JC61-00893A	HOLDER-M-PAD ADF	1	X	
8.10-3-2-2	JC61-00387A	SPRING ETC-PAD	1	X	
8.10-3-2-3	JC63-00373A	SHEET-ADF HOLDER	1	X	
8.10-3-2-4	JB73-00052A	RMO-ADF RUBBER	1	X	
8.10-3-2-5	JC66-00738A	DAMPER-PAD ADF R2	2	X	
8.10-4	JC97-01962A	MEA UNIT-PICKUP DELL	1	X	
8.10-4-1	JC72-00734A	PMO-COVER ADF	1	X	
8.10-4-2	JB66-00103A	GEAR-ADF 38	1	X	
8.10-4-3	JC61-00963A	STOPPER-M-PICKUP ADF	1	X	
8.10-4-4	6044-000159	RING-C	1	X	
8.10-4-4	JC66-00561A	SHAFT-ADF PICKUP	1	X	
8.10-4-5	JB70-00168A	ICT-PIN ADF	2	X	
8.10-4-6	6031-000023	WASHER-PLAIN	1	X	
8.10-4-7	JB66-00102A	GEAR-PICK UP IDEL 38	1	X	
8.10-4-8	JB75-00300A	MEC-PICK UP ROLLER ASSY	1	X	
8.10-4-8A	JB72-00823A	PMO-SLEEVE PICK UP	1	X	
8.10-4-8B	JB73-00055A	RMO-PICKUP ROLLER	1	X	
8.10-4-9	JB72-00821A	PMO-ADF COLAR	1	X	
8.10-4-10	JB61-70904A	SPRING ETC-CLUTCH	1	X	
8.10-4-11	JB72-00817A	PMO-ADF CLUTCH	1	X	
8.10-4-12	JB66-00104A	GEAR-ADF IDLE 34	1	X	
8.10-4-13	JC72-00744A	PMO-SHAFT PICK UP	1	X	
8.10-4-14	JB66-00105A	GEAR-PICK UP 26	1	X	
8.10-4-15	JB72-00845A	PMO-PICK UP CLUTCH SUB	2	X	
8.10-4-16	JB75-00299A	MEC-ADF ROLLER ASSY	1	X	
8.10-4-16A	JB73-00054A	RMO-ADF ROLLER	1	X	
8.10-4-16B	JB72-00822A	PMO-SLEEVE ADF	1	X	
8.10-5	JC97-02671A	MEA UNIT-COVER OPEN	1	O	
8.10-5-1	JC63-00371c	COVER-M-ADF OPEN R2	1	X	
8.10-5-2	JB72-00843A	PMO-GUIDE PAPER	2	X	
8.10-5-3	JC66-00726A	DAMPER-PICK UP ADF	1	X	

**8.11 Cover Platen**

Drawer#	SEC Parts Code	Description and Specification	QT'y	FRU Item (O/X)	Remark
8.11-0	JC96-03788A	ELA HOU-PLATEN	1	O	
8.11-1	JC97-01938A	MEA UNIT-TX STACKER	1	X	
8.11-1-1	JC63-00457A	COVER-M-STACKER TX DELL	1	X	
8.11-1-2	JC61-00959A	GUIDE-M-DOCU L_DELL	1	X	
8.11-1-3	JC61-00958A	GUIDE-M-DOCU R_DELL	1	X	
8.11-1-4	JF70-10616A	IPR-WASHER SPRING CU	2	X	
8.11-1-5	JG66-40003A	GEAR-PINION	1	X	
8.11-2	JC63-00374A	COVER-M-PLATEN R2	1	X	
8.11-3	JC63-00209A	SHEET-WHITE SPONGE	1	X	
8.11-4	JC97-01961A	MEA UNIT-HINGE DELL	2	X	
8.11-5	JC61-00011A	SPRING ETC-FEED	6	X	
8.11-6	JF70-40521B	ICT-SHAFT PINCH	1	X	
8.11-7	JC66-00728A	ROLLER-ADF FEED	2	X	
8.11-8	JC66-00558A	SHAFT-IDLE FEED	2	X	
8.11-9	JG72-40663A	PMO-ROLL PINCH	2	X	

**8.12 OPE Unit**

Drawer#	SEC Parts Code	Description and Specification	QT'y	FRU Item (O/X)	Remark
8.12-0	JC96-03774A	ELA HOU-OPE	1	O	America
8.12-0	JC96-03774B	ELA HOU-OPE	1	O	Europe
8.12-1	JC63-00981A	COVER-M_OPE	1	X	
8.12-2	JC64-00131A	BADGE-DELL	1	X	
8.12-3	JC72-00672A	PCT-LCD WINDOW	1	X	
8.12-4	JC64-00252A	KEY-M_SELECT	1	X	
8.12-5	JC64-00238A	KEY-M_MENU	1	X	
8.12-6	JC64-00237A	KEY-M_TEL	1	X	
8.12-7	JC73-00229A	RUBBER-TEL MENU	1	X	
8.12-8	JC92-01749A	PBA SUB-OPE	1	X	

### 8.13 Scanner Ass'y

Drawer#	SEC Parts Code	Description and Specification	QT'y	FRU Item (O/X)	Remark
8.13-0	JC96-03778A	ELA HOU-SCAN	1	X	
8.13-1	JC97-02445A	MEA UNIT-SCAN UPPER	1	X	
8.13-1-1	JC97-01941A	MEA UNIT-SCAN DUMMY	1	X	
8.13-1-1-1	JC63-00456A	COVER-M-SCAN DUMMY DELL	1	X	
8.13-1-1-2	JC74-00021A	MCT-GLASS ADF	1	X	
8.13-1-1-3	0203-001744	TAPE-DOUBLE FACE	1	X	
8.13-1-1-6	JC02-00013A	TAPE ETC-DOUBLE TAPE SMALL	1	X	
8.13-1-1-7	JB68-00644A	LABEL(P)-SHADING	1	X	
8.13-1-1-8	0203-001266	TAPE-DOUBLE FACE	1	X	
8.13-1-2	JC63-00380B	COVER-M_SCAN UPPER	1	X	
8.13-1-3	JC01-00001A	GLASS-SCAN	1	X	
8.13-1-4	0203-001267	TAPE-DOUBLE FACE	1	X	
8.13-1-5	JB70-00148A	IPR-HOLDER GLASS	2	X	
8.13-2	JC96-03786A	ELA HOU-SCAN LOWER	1	X	
8.13-2-1	JC63-00980A	COVER-M_SCAN LOWER	1	X	
8.13-2-2	JC96-03069A	ELA HOU-SCAN MOTOR	1	X	
8.13-2-2-1	JC61-00895A	BRACKET-SCAN MOTOR R2	1	X	
8.13-2-2-2	JC66-00531A	GEAR-TIMING	1	X	
8.13-2-2-3	JB72-00764A	PMO-HOLDER BELT	1	X	
8.13-2-2-3	JB72-00764A	PMO-HOLDER BELT	1	X	
8.13-2-2-4	6044-000125	RING-E	1	X	
8.13-2-2-5	JB66-00083A	GEAR-IDLE	1	X	
8.13-2-2-6	JC66-00530A	GEAR-REDUCTION73/37	1	X	
8.13-2-2-7	JB31-00011A	MOTOR STEP-SCAN	1	X	
8.13-2-3	JC96-03819A	ELA HOU-CCDM_2905	1	X	
8.13-2-4	JB70-00145A	ICT-SHAFT CCD	1	X	
8.13-2-5	JC39-00514A	CBF SIGNAL-CCD FFC	1	X	
8.13-2-6	JB72-00763A	PMO-PULLEY	1	X	
8.13-2-7	6602-001067	BELT-TIMING GEAR	1	X	
8.13-2-9	6044-000125	RING-E	1	X	
8.13-2-10	JB61-00059A	SPRING ETC-BELT	1	X	
8.13-2-11	6107-001135	SPRING-CS	1	X	
8.13-2-12	JC72-00755A	PMO-LEVER SENSOR	1	X	
8.13-2-13	0604-001095	PHOTO-INTERRUPTER	2	X	
8.13-2-14	JC39-00535A	CBF HARNESS-PLA_COVER	1	X	
8.13-2-15	JC39-00531A	CBF HARNESS-CCD_HOME	1	X	
8.13-2-16	JB96-01381A	ELA UNIT-CORE	3	X	
8.13-2-16-1	3301-001413	CORE-FERRITE	1	X	
8.13-2-17	JC39-00513B	CBF HARNESS-OPE	1	X	
8.13-2-18	JC61-00894A	HOLDER-M-CCD	1	X	
8.13-3	JC96-03774A	ELA HOU-OPE	1	O	America
8.13-3	JC96-03774B	ELA HOU-OPE	1	O	Europe

### 8.14 Cassette Ass'y

Drawer#	SEC Parts Code	Description and Specification	QT'y	FRU Item (O/X)	Remark
8.14-0	JC97-02414A	MEA UNIT-CASSETTE	1	O	
8.14-0	JC96-03854A	OPTION-CASSETTE(250 Sheet)	1	O	
8.14-1	JC70-00300G	ADJUST-M-CST L_DELL	1	X	
8.14-2	JC70-00301G	ADJUST-M-CST R_DELL	1	X	
8.14-3	JG66-40003A	GEAR-PINION	1	X	
8.14-4	JC97-01931A	MEA UNIT-HOLDER PAD	1	X	
8.14-4-1	JC61-00580A	HOLDER-M-PAD	1	X	
8.14-4-2	JC63-00407A	SHEET-HOLDER PAD R2	1	X	
8.14-4-3	JC70-00314A	IPR-PLATE PAD	1	X	
8.14-4-4	JC73-00140A	RPR-FRICTION PAD	1	X	
8.14-5	JC61-70911A	SPRING ETC-EXIT ROLL FD	1	X	
8.14-6	JC61-00603A	PLATE-P-KNOCK_UP	1	X	

Drawer#	SEC Parts Code	Description and Specification	QT'y	FRU Item (O/X)	Remark
8.14-7	6107-001166	SPRING-CS	2	X	
8.14-8	JC73-00141A	RPR-PAD CASSETTE	1	X	
8.14-9	JC66-00719A	CAM-M-KNOCK UP	1	X	
8.14-10	JC61-00876G	FRAME-M CASSETTE	1	X	
8.14-11	JC61-00918L	GUIDE-M EXTENSION L	1	X	
8.14-12	JC61-00960A	GUIDE-M-EXTEND S DELL	1	X	
8.14-13	JC72-00972A	PMO-PLATE LOCKER	1	X	
8.14-14	JG61-70531A	SPRING ETC-LOCKER_PLATE	1	X	
8.14-15	JC63-00955A	COVER-M SUB CST	1	X	

### 8.15 Fuser Ass'y

Drawer#	SEC Parts Code	Description and Specification	QT'y	FRU Item (O/X)	Remark
8.15-0	JC96-03801A	ELA UNIT-FUSER 110V	1	O	110V
8.15-0	JC96-03802A	ELA UNIT-FUSER 220V	1	O	220V
8.15-1	JC61-01632A	FRAME-P-FUSER	1	X	
8.15-2-3	JC66-00426B	GEAR-IDLE 23	1	X	
8.15-2-4	6044-000231	RING-E	2	X	
8.15-2-4	JC66-00425A	GEAR-IDLE 33	1	X	
8.15-3	JC39-00520A	CBF HARNESS-FUSER CON	1	X	
8.15-4	4712-001031	THERMOSTAT	1	X	
8.15-5	1404-001364	THERMISTOR-NTC ASSY	1	X	
8.15-6	JC61-00785A	HOLDER-M-IDLE ROLLER	2	X	
8.15-7	JC72-40981A	PMO-ROLLER UPPER DP	2	X	
8.15-8	JC39-00521A	CBF HARNESS-FUSER REC	1	X	
8.15-9	JC72-41128B	PMO-GUIDE CLAW GREEN	4	X	
8.15-10	6107-001291	SPRING-ES	4	X	
8.15-11	JC72-20902A	PEX-ROLLER F/UP(2)	2	X	
8.15-12	JC70-20901A	IEX-SHAFT IDLE,F/UP	2	X	
8.15-13	6107-001159	SPRING-TS	2	X	
8.15-15	JC61-01627A	BRACKET-P-FUSER	1	X	
8.15-16	JC61-01306B	HOLDER-M JAM R	1	X	
8.15-17	JC61-01305B	HOLDER-M JAM L	1	X	
8.15-29	6107-001237	SPRING-ES	1	X	
8.15-19	JC66-00957A	LEVER-M_LINK JAM	2	X	
8.15-20	6044-000125	RING-E	4	X	
8.15-21	JC63-01005A	COVER-M_FUSER	1	X	
8.15-22	JC61-01633A	GUIDE-M_REAR	1	X	
8.15-23	JC72-00988A	PMO-ACTUATOR EXIT	1	X	
8.15-24	JC61-70903A	SPRING ETC-ACTUATOR	1	X	
8.15-25	JC72-00382A	PMO-BUSHING TX	3	X	
8.15-26	JC66-00402A	SHAFT-M-EXIT_F/UP	1	X	
8.15-27	JC66-40209A	GEAR-EXIT	1	X	
8.15-28	JC61-01625B	HOLDER-M_REAR_LEVER	1	X	
8.15-31	JC61-01699A	SPRING ETC-PR	2	X	
8.15-32	JC66-00599A	ROLLER-PRESSURE	1	X	
8.15-33	JC66-01194A	ROLLER-HEAT	1	X	
8.15-34	JC66-10901A	BEARING-PRESSURE/R	2	X	
8.15-35	JC61-01629A	BUSH-M_HR R	2	X	
8.15-36	JC66-01192A	GEAR-M_FUSER	1	X	
8.15-37	4713-001207	LAMP-HALOGEN	1	X	110V
8.15-37	4713-001208	LAMP-HALOGEN	1	X	220V
8.15-37	JC75-00095A	MEC-BRUSH ANTISTATIC	1	X	
8.15-38	JC73-40909B	RMO-RUBBER EXIT_F/UP	2	X	

### 8.16 Duplex Unit

Drawer#	SEC Parts Code	Description and Specification	QT'y	FRU Item (O/X)	Remark
8.16-0	JC97-02393B	MEA UNIT-DUPLEX	1	X	
8.16-1	JC61-01594B	FRAME-M DUP	1	X	
8.16-2	JC61-01596A	BRACKET-P-ALIGN DUP	1	X	
8.16-3	JC61-00665A	BUSH-M-FEED, DUP	4	X	
8.16-4	JC96-03662B	ELA UNIT-ROLLER_DUP2	1	X	
8.16-5	6044-000107	RING-C	1	X	
8.16-6	JC66-00038A	GEAR-EXIT F/DOWN	1	X	
8.16-7	JC96-03662A	ELA UNIT-ROLLER_DUP	1	X	
8.16-8	JC66-00900A	PULLEY-M-18-DUMMY_DUP	3	X	
8.16-9	6003-000196	SCREW-TAPTITE	4	X	
8.16-10	JC65-00017A	TERMINAL-P-GND DUP	2	X	
8.16-11	JC61-01595A	GUIDE-M_UPPER DUP	1	X	
8.16-12	6107-001156	SPRING-TS	2	X	
8.16-13	JK72-00058A	PCT-SILP WASHER	4	X	
8.16-14	JC66-00896A	ROLLER-M-IDLE_DUP	2	X	
8.16-15	JC66-00444A	SHAFT-IDLE ROLL, DUP	2	X	

Drawer#	SEC Parts Code	Description and Specification	QT'y	FRU Item (O/X)	Remark
8.16-16	JC66-20901A	BELT-TIMMING	1	X	

# 9. Block Diagram

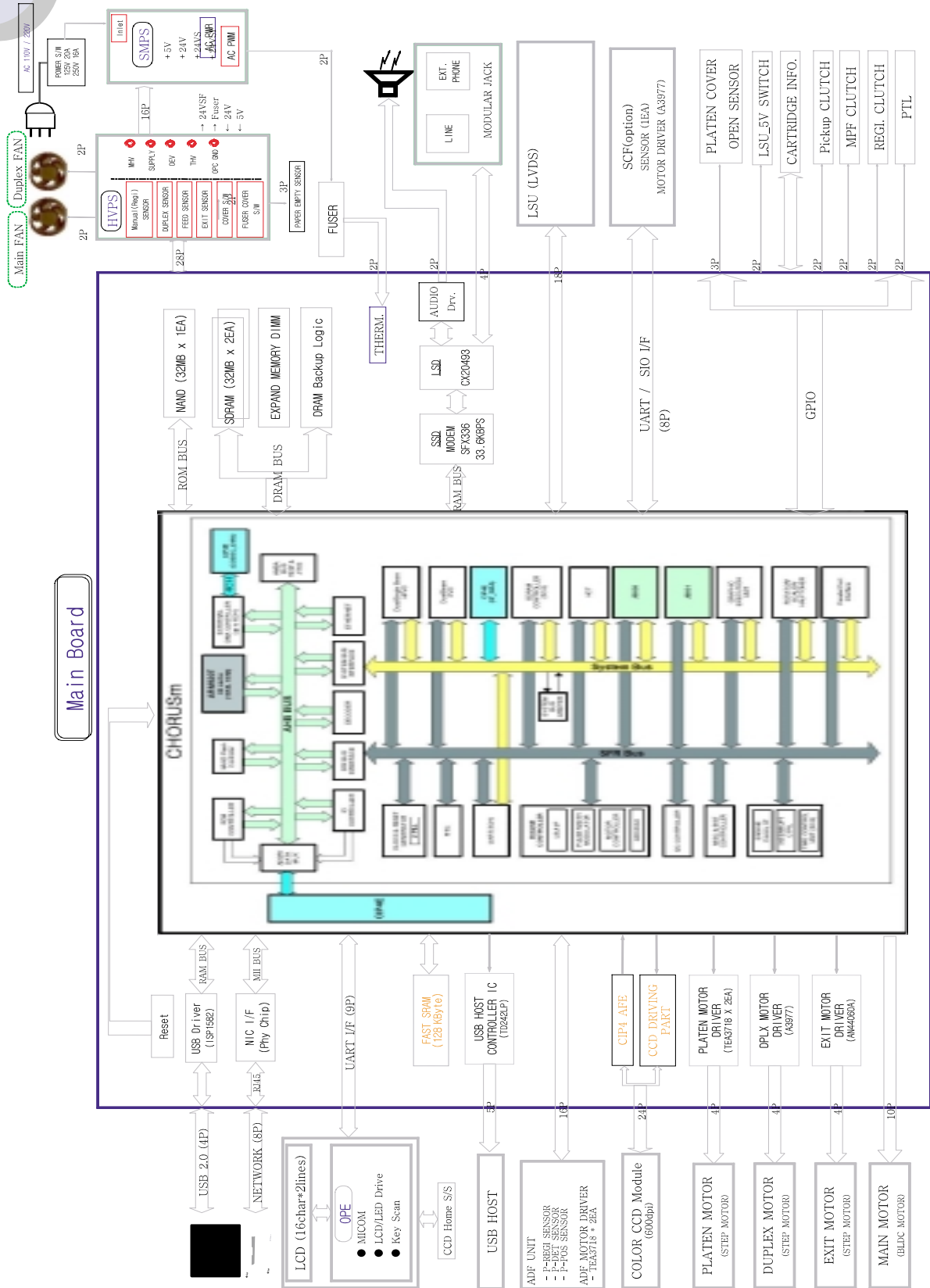

# 10. Connection Diagram

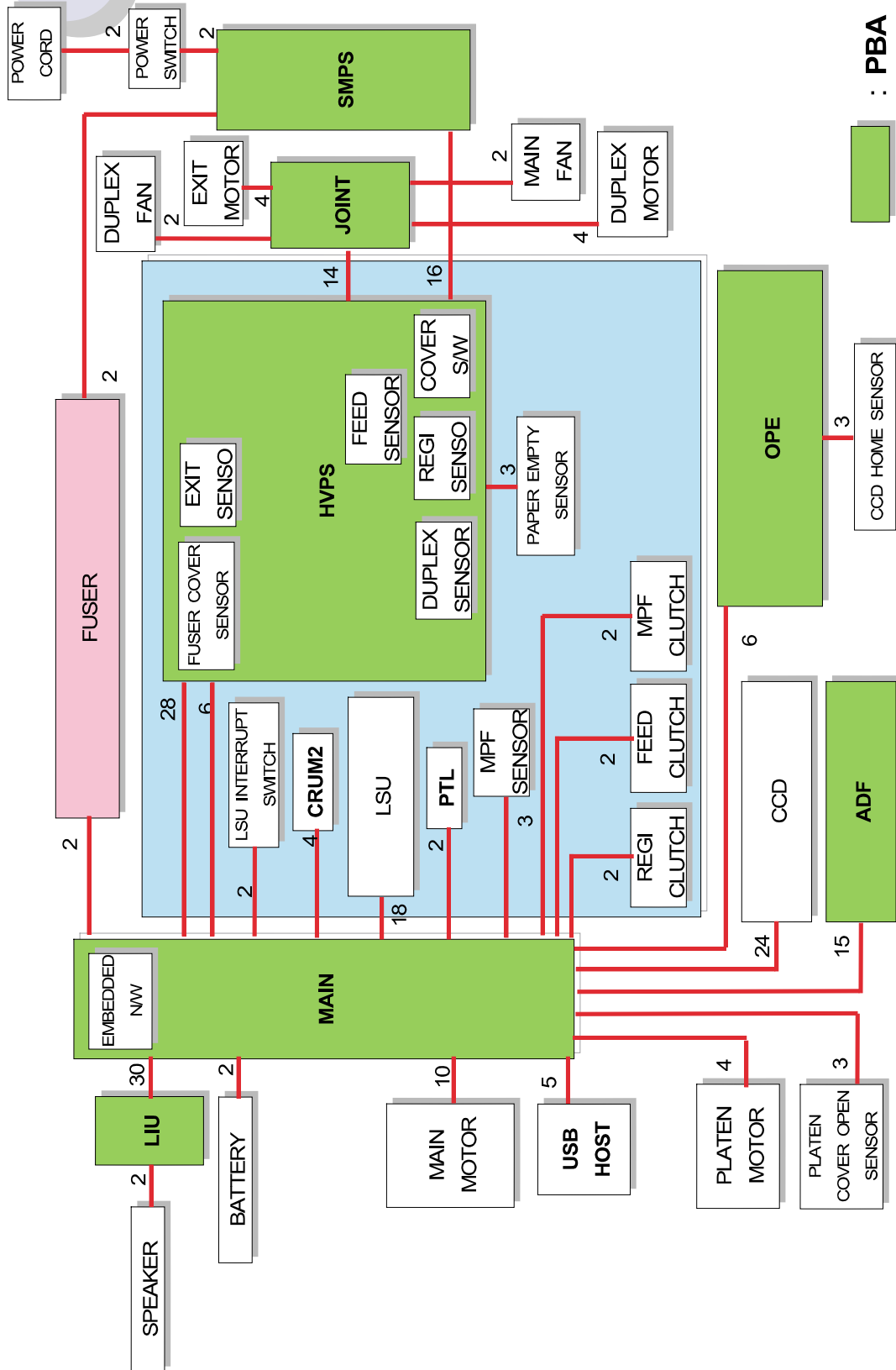

# Dell 1815dn - recommended spare part list

17 Oct 2006

<u>MFG P/N</u>	<u>MFG Part Description</u>	<u>Dell P/N</u>	<u>Dell Part Description</u>	<u>CRU or FRU</u>
<b>Base Unit</b>				
SCX-5525DN/DEL	110V Base Printer	KG194	Base Printer, 110V, (Advanced Exchange for US), 1815dn	CRU
SCX-5525DN/DLL	110V Base printer (with Icon Panel)	KG187	Base Printer, 110V, with Icon Panel (Advanced Exchange for Canada/Latin America), 1815dn	CRU
SCX-5525DN/DEH	ASSY,BASE,PTR,EMEA1,HV,1815DN	MH673	Base Printer, 220V, (Whole Unit Exchange for EMEA), 1815dn	CRU
<b>Accessory</b>				
SCX-D5525A/DEL	3K Toner Cartridge	NF485	Toner Cartridge (3K pages @ 5% coverage A4), 1815dn	CRU
SCX-D5525B/DEL	5K Toner Cartridge	RF223	Toner Cartridge (5K pages @ 5% coverage A4), 1815dn	CRU
JC97-02414A	MEA UNIT-CASSETTE	HF828	Main Paper Tray, 250 sheets, 1815dn	CRU
SCX-S5525A/DEL	250 Sheet Drawer	UF065	Optional Paper Cassette and Tray, 250 sheets, 1815dn	CRU
<b>Cables and Cords</b>				
TBD	CBL,USB,D4B-10,IJ-LJ,LT,BLK	WD420	Printer Cable, USB, Black, 10ft	CRU
3903-000085	KIT,CORD,POWER,PTR,DAO,1100	M9028	Power Cord, DAO, 1100/1110/1815dn	CRU
<b>Controller Cards</b>				
JC92-01636A	PBA SUB-USB HOST	RF276	USB PBA, 1815dn	FRU
JC92-01744A	PBA MAIN-CONTROLLER	TG817	Printer Controller Board, 1815dn	FRU
<b>Documentation</b>				
JC99-01936A	Doc Kit, US	HF830	Doc Kit, US, 1815dn	CRU
JC99-01936B	Doc Kit, LA/CA	MF722	Doc Kit, Canada/Latin America, 1815dn	CRU
JC99-01936C	Doc Kit, EMEA	NF923	Doc Kit, English, EMEA, 1815dn	CRU
JC99-01936D	Doc Kit, ISR-ZA	UF224	Doc Kit, English/French/Italian/German/Spanish, EMEA, 1815dn	CRU
<b>Heatsinks, Fans and Accessories</b>				
JC31-00025A	FAN-DC	N5682	Main Fan, 1815dn	FRU
JC31-00025B	FAN-DC	TH973	Fuser Fan, 1815dn	FRU
<b>Mechanical/Chassis</b>				
JC97-02421A	MEA-COVER SIDE L	FG480	Left Side Cover, 1815dn	FRU
JC63-00947A	COVER-M_SIDE R	FG481	Right Side Cover, 1815dn	FRU
JC97-02423A	MEA-COVER FRONT	FG482	Front Door Cover, 1815dn	FRU
JC96-03794A	ELA HOU-COVER MID	YH932	Output Tray, 1815dn	FRU
JC97-02671A	MEA UNIT-COVER OPEN;SCX-4920N,	DJ026	Cover Top, ADF, 1815dn	CRU
JC97-02393B	MEA UNIT-DUPLEX	NF802	Duplex Unit, 1815dn	FRU
JC96-03837A	ELA HOU-MPF	PF661	Bypass Tray Assembly, 1815dn	FRU
JC97-02034A	MP Assy Pickup Roller	TF129	Bypass Tray Pickup Roller, 1815dn	FRU
JC97-02422A	MEA-COVER REAR	KJ157	Cover Rear, 1815dn	FRU
JC63-00950A	COVER-M_DIMM	GJ642	Memory Door, 1815dn	CRU
JC96-03829A	ELA HOU-GUIDE DUP F	UF153	Duplex Guide Housing, 1815dn	FRU
JC97-01962A	MEA UNIT-PICKUP	M5512	ADF Pickup Assembly, 1600n/1815dn	CRU
JC97-01940A	MEA UNIT-HOLDER ADF	4M346	ADF Rubber Pad, 1600n/1815dn	CRU
JC97-02441A	MEA-ROLLER PICK UP	UG594	Pickup Roller, 1815dn	FRU
<b>Memory</b>				
MICRON: MT4LSDT832UDY8G1	KIT,PTR,MEM,32MB,SDRAM-DIMM	MF483	32MB, Memory, SDRAM-DIMM	CRU
MICRON: MT4LSDT1632UDY8G1	KIT,PTR,MEM,64MB,SDRAM-DIMM	HF710	64MB, Memory, SDRAM-DIMM	CRU
MICRON: MT4LSDT3232UDY8D1 / KINGSTON: KTD133100/128	KIT,PTR,MEM,128MB,SDRAM-DIMM	HF713	128MB, Memory, SDRAM-DIMM	CRU
<b>Miscellaneous Hardware</b>				
JC59-00027A	UNIT-LSU	YF792	Printhead, 1815dn	FRU
JC96-03761A	ELA UNIT-MAIN DRIVE	GJ406	Main Gear Assembly, 1815dn	FRU
JC96-03801A	ELA UNIT-FUSER_110V	UG297	Fuser, 110V, 1815dn	FRU
JC96-03802A	ELA UNIT-FUSER_220V	UG298	Fuser, 220V, 1815dn	FRU
JC96-03760B	ELA HOU-FRAME ETC	GJ445	Frame Assembly, 1815dn	FRU

JC96-03810A	ELA HOU-ADF	TH959	ADF Engine Assembly, 1815dn	FRU
JC96-03774A	ELA HOU-OPE	KJ544	OP Panel Assembly for America in English, 1815dn	FRU
JC96-03774B	ELA HOU-OPE	GJ636	OP Panel Assembly for Europe & Others in symbol, 1815dn	FRU
JC96-03762A	ELA UNIT-DUPLEX DRIVE	RF274	Duplex Drive, 1815dn	FRU
JC97-02652A	MEA-TRANSFER ROLLER	WJ045	Transfer Roller, 1815dn	FRU
JC96-03778A	SCANNER ASSY	PF762	Scanner Assembly, 1815dn	FRU
JC92-01828A	PBA SUB-CONNECTION	PF044	PBA Sub-Connection, 1815dn	FRU
JC96-03788A	ELA HOU-PLATEN	UG593	Platen Assembly, 1815dn	FRU
<b>Modems, Accessories</b>				
JC92-01746B	PBA SUB-MODEM	JJ312	Modem Card, 1815dn	FRU
JC99-01769B	Fax Terminator Plug	U4718	FAX Terminator Plug, 1600n/1815dn	CRU
<b>Power Source</b>				
JC44-00090A	SMPS-PSP_TYPE3_V2	WH770	LVPS, 220V, 1815dn	FRU
JC44-00097A	SMPS-PSP_TYPE3_V1	WH768	LVPS, 110V, 1815dn	FRU
JC44-00107A	HVPS-ELBERT	WH773	HVPS, 1815dn	FRU

Notes

CRU : Customer Replaceable Units - refers to parts that can easily be replaced by the customer without sending an onsite technician.

FRU : Field Replaceable Unit - a part that can be replaced or added by onsite technician.



## Free Manuals Download Website

<http://myh66.com>

<http://usermanuals.us>

<http://www.somanuals.com>

<http://www.4manuals.cc>

<http://www.manual-lib.com>

<http://www.404manual.com>

<http://www.luxmanual.com>

<http://aubethermostatmanual.com>

Golf course search by state

<http://golfingnear.com>

Email search by domain

<http://emailbydomain.com>

Auto manuals search

<http://auto.somanuals.com>

TV manuals search

<http://tv.somanuals.com>