

Definitive Technology[®]
The Leader in High-Performance Loudspeakers[®]

Mythos STS

Mythos STS SuperTower[®] Loudspeaker with Built-In Powered Subwoofer

Owner's Manual

Thank You

Thank you for choosing the Definitive Technology Mythos STS SuperTower Loudspeaker System. The Mythos STS is a unique speaker which includes a built-in powered subwoofer system with a high-power digital amplifier. This extraordinary speaker truly revolutionize the state-of-the-art in music and home theater loudspeaker technology and performance. You chose wisely.

Our engineers have spent many years in developing this product. In order to ensure that you experience the finest performance possible, we encourage you to take a moment to fully read this owner's manual and familiarize yourself with the proper installation and set-up procedures for your Mythos STS speakers.

Safety Precautions



CAUTION! To reduce the risk of electric shock and fire, do not remove the cover or back plate of this device. There are no user serviceable parts inside. Please refer all servicing to licensed service technicians.
Avis: Risque de choc électrique, ne pas ouvrir.

CAUTION! The international symbol of a lightning bolt inside a triangle is intended to alert the user to uninsulated “dangerous voltage” within the device’s enclosure. The international symbol of an exclamation point inside a triangle is intended to alert the user to the presence of important operating, maintenance and servicing information in the manual accompanying the device.

CAUTION! To prevent electrical shock, match wide blade of plug to wide slot, fully insert. Attention: Pour éviter les chocs électriques, introduire la lame la plus large de la fiche dans la borne correspondante de la prise et pousser jusqu’au fond.

CAUTION! To reduce the risk of electrical shock, do not expose this equipment to rain or moisture.

1. Read Instructions—All safety and operating instructions should be read before operating the device.
2. Retain Instructions—The safety and operating instructions should be retained for future reference.
3. Heed Warnings—All warnings on the device and in the operating instructions should be adhered to.
4. Follow Instructions—All operating and safety instructions should be followed.
5. Water & Moisture—The device should never be used in, on or near water for risk of fatal shock.
6. Carts & Stands—The device should only be used on carts or stands recommended by the manufacturer.
7. Wall & Ceiling Mounting—The device should be mounted on a wall or ceiling only as recommended by the manufacturer.
8. Ventilation—The device should always be located in such a way that it maintains proper ventilation. It should never be placed in a built-in installation or anywhere that may impede the flow of air through its heat sink.
9. Heat—Never locate the device near heat sources such as radiators, floor registers, stoves or other heat-generating devices.
10. Power Supply—The device should only be connected to a power supply of the type described in the operating instructions or as marked on the device.
11. Power Cord Protection—Power cables should be routed so they are not likely to be stepped on or crushed by items placed on them or against them. Special attention should be paid to areas where the plug enters a socket or fused strip and where the cord exits the device.
12. Cleaning—The device should be cleaned in accordance with manufacturer’s instructions.
13. Periods Of Non-Use—The device should be unplugged when not being used for extended periods.
14. Dangerous Entry—Care should be taken that no foreign objects or liquids fall or are spilled inside the device.
15. Damage Requiring Service—The device should be serviced by licensed technicians when:
 - The plug or power supply cord has been damaged.
 - Objects have fallen or liquid has spilled inside the device.
 - The device has been exposed to moisture.
 - The device does not appear to be operating properly or exhibits a marked change in performance.
 - The device has been dropped or the cabinet becomes damaged.
16. Service—The device should always be serviced by licensed technicians. Only replacement parts specified by the manufacturer should be used. The use of unauthorized substitutions may result in fire, shock, or other hazards.

Safety Precautions Specific to Mythos STS

The cautionary marking label is located on the bottom of the speaker, visible through an opening in the granite base.

Power Supply

1. The fuse and power disconnect device are located on the bottom of the speaker, accessible through a hole in the granite base.
2. The disconnect device is the power cord, detachable at either the speaker or the wall.
3. The power cord must be disconnected from the speaker before servicing.

Unpacking Your Mythos STS

Please Inspect For Shipping Damage

Each loudspeaker leaves our plant in perfect condition. Any visible or concealed damage most likely occurred in handling after it left our plant and should be reported at once to your Definitive dealer or the delivery company that delivered your loudspeaker. Please unpack your system carefully. Save all cartons and packing materials in case you move or need to ship your system. Record the serial number found on the back of the Mythos STS in the appropriate place on your warranty card, answer all questions and send it in.

VERY IMPORTANT: Accessories

Various parts and accessories that you will need to assemble your Mythos STS are in the carton but are easy to overlook. Open both ends of the shipping carton. Carefully examine the contents of the shipping carton and packing material to find the plastic bags with accessories.

Base Installation Instructions

Tools required: 4mm (or $\frac{5}{32}$ ") Allen wrench (also called Hex Key driver) included in carton

Parts required: Polished Granite Base, Cable Clip for AC Cord, four Allen head bolts, eights plastic washers. All required parts are included in the product carton.

Instructions:

1. Carefully lay the Mythos STS on its side. Lift the base of the speaker about six inches and support it with a soft padded object, such as a pillow. Do NOT support the speaker with a hard object, as you might dent or scratch the aluminum finish.
2. Place one plastic washer on each bolt.
3. Insert the bolts into the granite base from the bottom (the same side that the levelling feet are attached).

4. Place another plastic washer on each bolt so the washer is against the granite.
5. Finger tighten all four bolts into the threaded holes on the bottom of the Mythos. If this has been done correctly, washers will be between the metal surface of the Mythos STS, the granite, and the heads of the bolts.
6. GENTLY tighten each bolt with the Allen wrench. Do NOT overtighten or you may crack the granite.
7. Attach the AC cord through the hole at the bottom of the granite base.
8. Note the label showing the height adjustment ring and locking collar on the levelling feet. Carefully return the speaker to the upright position and adjust the feet to level the speaker.

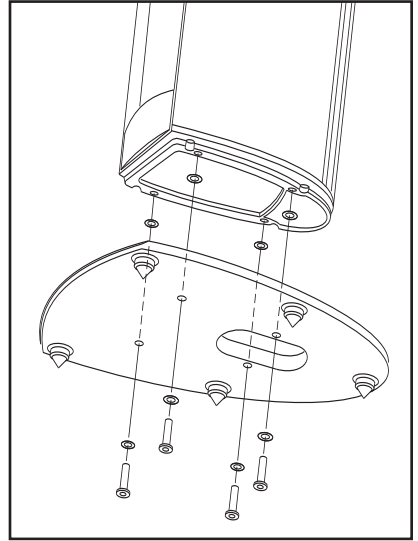

Installing Cable Clip for AC Cord

The cable clip supplied in the accessories bag holds the power cable in place to prevent accidental disconnection of the cable from the inlet socket. To use, peel backing and apply to bottom of granite base half-way between center opening and back of the base, slightly off to one side of the rear foot, as shown in the diagram. After plugging supplied power cable into the inlet socket, it may then be pressed into the opening in the cable clip to secure it in place.

SELF-ADHESIVE POWER CABLE
RESTRAINING CLIP FOR MYTHOS STS

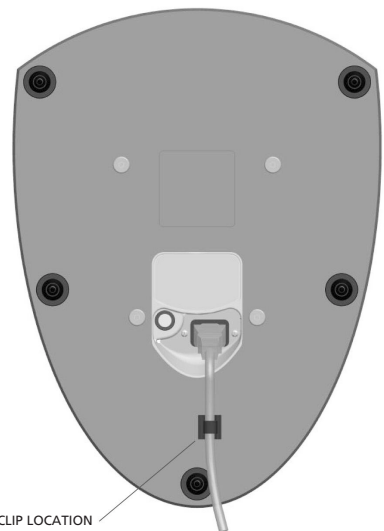
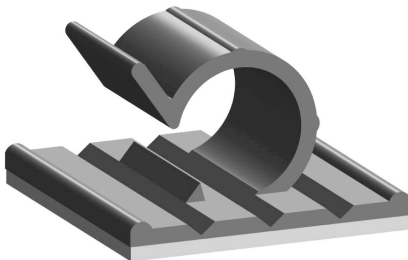

SUGGESTED CLIP LOCATION

Installing Leveling Feet and Spikes

We have provided leveling feet and metal spikes with your Mythos STSs; they are in the same bag as this manual. The plastic tips are for hard floor surfaces such as tile and wood while the metal spikes are for use on carpeted floors. Be careful when using spikes as they may cause damage to wooden or other floors which are susceptible to being scratched. Definitive Technology is not responsible for floor damage which may result from the use of spikes.

Screw the leveling feet into the five threaded inserts on the bottom of the base. If you plan on using spikes, it would be best to experiment with speaker positioning first, then add the spikes once you are sure you've determined the speakers' permanent position. To install the carpet spikes, unscrew the non-marking tips from the centers of the five leveling feet and screw the spikes in their places. Then, with the help of another person, lift the speaker upright and lower it to the desired location; push down on the top of the speaker to force the spikes through the carpet and make contact with the floor beneath.

Once you have positioned the speakers, wiggle them to see if they are stable and level. Adjust the height of the leveling feet/spikes accordingly for best stability.

Positioning the Mythos Speakers in Your Room

Your new Mythos speakers are very flexible in terms of positioning and placement options and they will produce excellent sound in almost any location. Following a few simple guidelines will, however, optimize their performance for the more critical listener. Although the following recommendations will usually yield the best results, all rooms and listening sets-ups are different, so do not be afraid to experiment with the speaker placement. Whatever sounds best to you is correct.

Positioning Mythos STS as Left/Right Main Speakers

For best results create an equilateral triangle between the speakers and the listening position as shown in the illustration. Angle the speakers toward the center of the listening position for brighter, clearer sound with a sharper focus and a more solid central image (recommended). Pointing the speakers straight forward, parallel with each other, will result in a warmer less sharply focused sound.

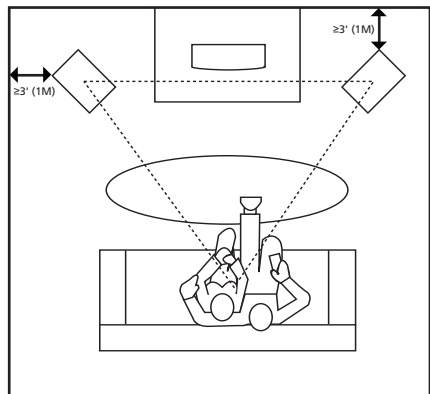

The Mythos STSs are magnetically shielded for safe placement near TV or video monitors. If you notice video distortion or discoloration, immediately move the speakers farther away from the video display. To get the best possible imaging and most even tonal response avoid placing the speakers less than 3 feet (1 Meter) from back and side walls.

Positioning Mythos STS as Rear/Side Surrounds

When used as rear or side surround speakers, Mythos STSs may be located on the side or behind the listeners. When used on the sides, take care never to locate the speakers forward of the listeners (figure A). When the side/rear speakers are close to the listening position, do not aim the speakers at the listeners. If positioned several feet behind the listener, experiment with speaker aiming (figure B).

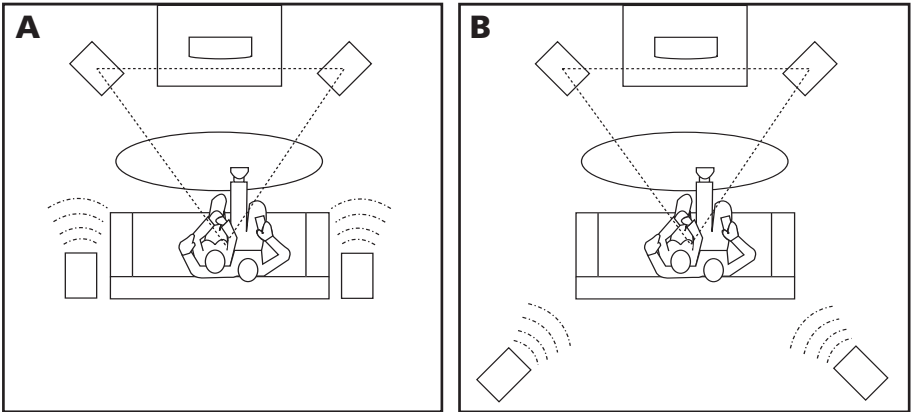

Connecting Your Loudspeakers

Connecting Mythos STS to a Two-Channel System

Your Mythos STSs have a set of speaker level (high level) 5-way binding posts plus an LFE input. If you are using your Mythos STS in a two channel system you only need connect to the high-level binding posts. To start, strip $\frac{1}{2}$ inch (12.7mm) of insulation from each of the two conductors of the speaker wire to expose the bare metal and twist each of the individual conductors into single unfrayed strands. Note that one of the terminals on the rear of each speaker is marked with red band (+) and the other is marked with black band (-).

Make certain that you connect the wire from the red (+) terminal of your amplifier or receiver to the red (+) terminal on your speaker and the wire from the black (-) terminal of your amplifier or receiver to the black (-) terminal on your speaker. Most speaker wire has

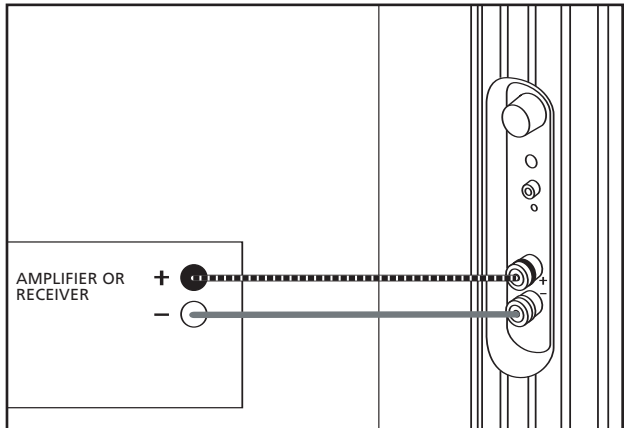

some indicator (such as color-coding, ribbing or writing) on one of the two conductors to help you maintain consistency. It is essential to connect both speakers to the amplifier in the same way (in phase). If you experience a lack of bass, it is likely that one speaker is out of phase with the other and needs to be rewired paying closer attention to connect positive to positive; negative to negative on both channels.

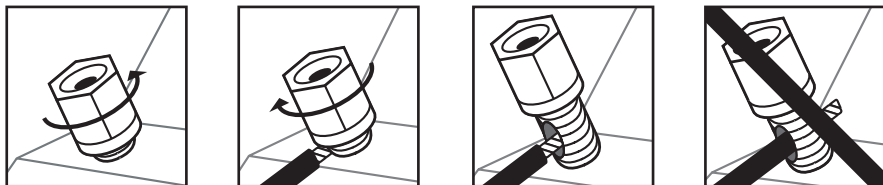

To connect wire to the binding post [see figure above], unscrew the hex nut and insert the bare wire into the hole near the base of the binding post. Do not insert the insulated part of the wire into the hole as this will not give you a good connection. Twist the hex nut back down the binding post until it firmly meets the wire. Do not over tighten.

Connecting Mythos STS to a Multi-Channel Home Theater System

Your Mythos STSs have a set of speaker level (high level) 5-way binding post speaker inputs to feed in the left and right channel signals plus an LFE input to separately feed the discrete “Low Frequency Effects” channel into each subwoofer. Unlike a conventional system, where the subwoofer is driven only by an LFE subwoofer signal, the Mythos STSs are much more sophisticated and can play by the left and right channel bass signal as well as the LFE signal. For optimum performance, please fully read and closely follow the directions in this manual.

To start, strip $\frac{1}{2}$ inch (12.7mm) of insulation from each of the two conductors of the speaker wire to expose the bare metal and twist each of the individual conductors into single unfrayed strands. Connect the left front channel red (+) terminal of your receiver or amplifier to the red marked (+) terminal of your left loudspeaker and the left front channel black marked (-) terminal of your receiver or amplifier to the black (-) terminal of your left loudspeaker. Connect the right channel main/front channel red (+) terminal of your amplifier or receiver to the red (+) terminal of your right loudspeaker and the black (-) terminal of the right main/front channel of your receiver or amplifier to the black (-) terminal of your right loudspeaker. Most speaker wire has some indicator (such as color-coding, ribbing or writing) on one of the two conductors to help you maintain consistency. It is essential to connect both speakers to the amplifier in the same way (in phase). If you experience a lack of bass, it is likely that one speaker is out of phase with the other and needs to be rewired paying closer attention to connect positive to positive; negative to negative on both channels.

Connecting the Low Frequency Effects (LFE) Channel

Connect a “Y” connector (available from your dealer) from the LFE output on your receiver or processor to feed two line level cables, connecting one to the LFE input on your left Mythos STS and the other to the LFE input on your right speaker. When using the LFE inputs, set your receiver’s or processor’s Speaker Set Up (bass management) as Front = Large, Subwoofer = Yes (On).

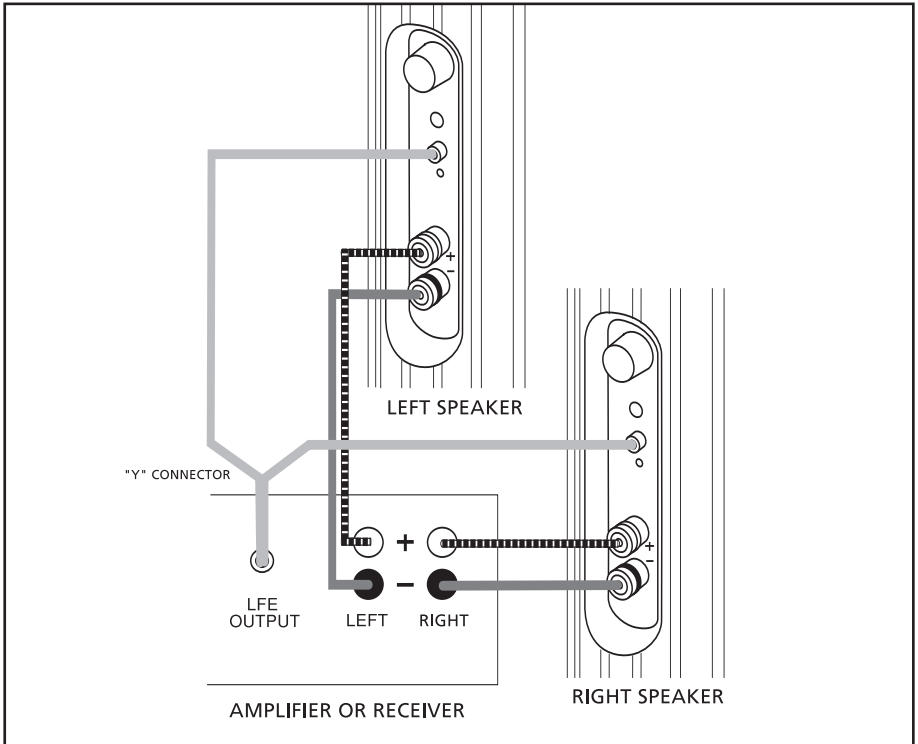

Setting Low-Frequency Balance When Using LFE Input

In the receiver’s or processor’s speaker level menu be sure to set the subwoofer volume to match that of the other channels in the system. Consult your receiver’s manual for specific instructions on setting speaker levels.

Speaker Wire Only Multi-Channel System Hook-Up

If you do not want to complicate your system hook up by connecting to the Mythos STS’ LFE inputs, simply connect to the speakers’ high-level input binding posts as described above and set your receiver’s or processor’s Speaker Set Up (bass management) as Front = Large, Subwoofer = No (Off). All of the front channel as well as the LFE bass will go to the Mythos STS.

VERY IMPORTANT: Setting Bass Management and Channel Balance

Dolby Digital and DTS multi-channel systems have critical channel balance and bass management procedures which must be followed if the system is to perform properly. We have spoken with many users with system sound problems which could be clearly traced back to improper system balance and bass management set-up. Consult your receiver's or processor's manual to learn how to access your system set up menus. If you have connected the LFE output of your receiver or processor to the LFE input of the Mythos STS, using the Speaker Set Up (or bass management) menu set the front left speakers as "Large" and subwoofer as "Yes." If you have connected the speakers using only speaker wire, set the front speakers as "Large" and subwoofer as "No."

If you have a Definitive center channel with a built-in powered subwoofer or other full range center channel, set your receiver's Speaker Set Up center channel setting to "Large" (although you should experiment with this to see what sounds best in your specific system). For almost every other center channel speaker set it as "Small." If you are using large rear surround speakers with very extended low frequency response such as a large Definitive floor-standing system or one with a built-in powered subwoofer, set the rear channels of your decoder's bass management system to "Large." If you are using medium to small-sized center and surround speakers, set them to "Small."

Use the Speaker Level menu in your receiver or processor to set each channel in the system to the same volume level. While you can get decent results doing this by ear, it is best to use an inexpensive Sound Pressure (SPL) meter to get perfect channel to channel balance. Some new receivers and processors have Auto Set Up functions that use a supplied microphone to set levels.

Using Multi-Channel SACD or DVD-Audio with your Mythos STS

Because of the nature of their bass management systems, a multi-channel SACD player or DVD-Audio player (or any other format that requires using 6-channel interconnects) requires the use of an LFE connection between your receiver or processor and your Mythos STS. If you are using one of these players, please use the connection method outlined in the "Connecting the Low Frequency Effects (LFE) Channel" section.

Surround Channel Hook-Up

If you are using the Mythos STS as side/rear surround speakers, hook up the left surround red (+) terminal of your receiver or amplifier to the red (+) terminal of your left surround speaker and the left surround black (-) terminal of your receiver or amplifier to the black (-) terminal of your left surround speaker. Connect the right surround red (+) terminal of your amplifier or receiver to the

red (+) terminal of your right surround loudspeaker and the black (-) terminal of the right surround channel of your receiver or amplifier to the black (-) terminal of your right surround loudspeaker. Most speaker wire has some indicator (such as color-coding, ribbing or writing) on one of the two conductors to help you maintain consistency. It is essential to connect both speakers to the amplifier in the same way (in phase). If you experience a lack of bass, it is likely that one speaker is out of phase with the other and needs to be rewired paying closer attention to connect positive to positive; negative to negative on both channels. Set the receiver's or processor's Speaker Set-Up menu as Surround = Large.

Powering the Active Subwoofer

Your Mythos STSs contain a built-in, active powered subwoofer section as well as an electronic crossover and must be plugged into an electrical socket of the appropriate voltage (as indicated on the back of your unit) using the electrical cord which you have attached to the bottom of the speaker. The Mythos STS has a special circuit which automatically turns the powered subwoofer section on when a signal is fed to the loudspeaker and does not require an on-off switch. Please note that if you hear a pop from the speaker when the amp powers up, this is normal. The LED on the back panel will light up when a signal is sensed and the amplifier turns on. After the cessation of a signal, it may take up to an hour for the amplifier to actually turn off. In some instances, because of stray radio signals (RF) in your area, the LEDs may not turn off. However, this is nothing to be concerned about as the amplifiers draw almost no power when they are idling.

Setting Your Speakers' Low-Frequency Level Control

Your Mythos STSs have bass level controls which allow you to tune the output level of the powered subwoofers to match your room and personal listening preferences. Please note that there are no controls to vary the crossover points or phase because these have been factory calibrated and set to provide perfect blending (a major performance benefit of this innovative product). We suggest beginning with the level control set at approximately 1 o'clock.

Normally the level control of the left speaker will be set the same as the level control of the right speaker. However, these controls can also be set differently on the two speakers in order to allow you to vary the response of left and right speakers to compensate asymmetrical positioning of the speakers in your room (i.e., when one is closer to a side wall or corner, etc.). This is a useful feature which allows you much greater flexibility in loudspeaker placement, as well as the ability to compensate for what could otherwise be difficult placement situations.

To prevent accidental damage to the subwoofers built into your Mythos STSs from overdriving the system, the subwoofers feature an internal overload protection circuit, which will turn the subwoofers off or down when overdriven or overheated and will then resume normal operation after a few minutes.

Setting Low-Frequency Level When Using Separate LFE Input

If your Mythos STS built-in subwoofers are connected with the LFE input, first set the bass volume level on your Mythos STSs to sound balanced when listening to music in stereo. Then use your receiver or processor's Speaker Level (or Channel Balance) menu to set the subwoofer level to at least equal volume with the other speakers in the system. If you want more bass output on movies, you are better off raising the .1 channel subwoofer level in the Speaker Level menu than turning up the subwoofer volume control on the speakers.

Speaker Pre-Conditioning (Break-in)

Your Mythos STSs should sound good right out of the box; however, an extended pre-conditioning (break-in) period of 40-60 hours or more of normal playing is required to reach full performance capability. Pre-conditioning allows the driver suspensions to loosen and results in fuller bass, clearer more open midrange and smoother high frequency reproduction.

Using your Mythos STS with an Additional Subwoofer

Although the built-in subwoofers in your Mythos STSs deliver superb low frequency response and are all that are required for amazing performance, some listeners with large rooms may want to add an additional powered subwoofer to their system. If you choose to do so, we strongly suggest using a Definitive SuperCube subwoofer in order to achieve the highest level of sound quality possible. In this case connect the Mythos STS with the speaker wire only method and connect the LFE output to the separate subwoofer. Your receiver or processor's Speaker Set Up bass management system should be set to Front Speakers = "Large" and Subwoofer = "Yes."

Complete Home Theater Systems

We strongly suggest that you use matching Definitive center channel and rear/surround speakers to complete your Definitive home theater system. Please note that you can use Definitive Mythos STS SuperTowers as rear or side surround speakers with excellent results for both music and movies.

Setting Bass and Treble Controls on Your Receiver or Amplifier

Normally we recommend that you set the “Bass” and “Treble” controls on flat or 0 dB. This will give you the most linear and natural sound. If you want more bass, raise the subwoofer’s “Level” control on your Mythos STS, keeping in mind that even a little turn of the knob can make a big difference in the sound. Also, if your amplifier or receiver has a graphic equalizer, we recommend that you leave it flat. The reason for this is that we have spoken with many consumers about what they thought were improperly sounding speakers when, in fact the problem was misadjusted tone controls. When in doubt, leave them flat; this almost always sounds the best.

Audible distortion when the speakers are playing at loud levels is caused by driving (turning up) your receiver or amplifier louder than it or the speakers are capable of playing. Most receivers and amplifiers put out their full-rated power well before the volume control is turned all the way up, so the position of the volume control is a poor indicator its power limit. If your speakers distort when you play them loud, turn the volume down!

Troubleshooting

If you experience any difficulties with your Mythos STS loudspeakers, try the suggestions below. If you still have problems, contact your Definitive Technology Authorized Dealer for assistance.

1. Make sure all your system interconnects and power cords are solidly in place.
2. Should you hear hum or noise coming from your speakers, try plugging the speakers' power cords into a different AC circuit than your amplifier.
3. The system has sophisticated internal protection circuitry. If for some reason the protection circuitry trips, turn off your system and wait five minutes before trying the system again. If the speakers' built-in amplifier should overheat, the system will turn off until the amplifier cools down and resets.
4. Check to be sure that your power cord has not been damaged.
5. Check that no foreign objects or liquid has entered the speaker cabinet.
6. If you cannot get the subwoofer driver to turn on or if no sound comes out and you are sure the system is set up properly, please bring the loudspeaker to your Definitive Technology Authorized Dealer for assistance. Call First.

Service

Service and warranty work on your Definitive loudspeakers will normally be performed by your local Definitive Technology dealer. If, however, you wish to return the speaker to us, please contact us first, describing the problem and requesting authorization as well as the location of the nearest factory service center. **Please note that the address given in this booklet is the address of our offices only. Under no circumstances should loudspeakers be shipped to our offices or returned without contacting us first and obtaining return authorization.**

Definitive Technology Offices
11433 Cronridge Drive,
Owings Mills, Maryland 21117
Phone: (800) 228-7148 (US & Canada),
01 (410) 363-7148 (all other countries)

Technical Assistance

It is our pleasure to offer assistance if you have any questions regarding your Mythos STS or their set-up. Please contact your nearest Definitive Technology dealer or call us directly at (800) 228-7148 (US & Canada), 01 (410) 363-7148 (all other countries) or e-mail info@definitivetech.com.

Specifications

Mythos STS

Dimensions:	5½" W x 8½" D x 47½" H (height includes granite base & leveling feet/spikes)
Base Dimensions:	10½" W x 14" D
Frequency Response:	16 Hz – 30 kHz
Efficiency:	93 dB
Nominal Impedance:	4 – 8 ohms
Driver Complement:	Two 4½" high definition cast-magnesium basket midrange drivers. One 1" (25 mm) pure aluminum dome tweeter. One 5" x 10" long-throw racetrack subwoofer coupled to two 5" x 10" racetrack radiators.
Rec. Assoc. Amplification:	20 – 250 Watt/channel
Built-In Subwoofer	
Power Amplifier:	300 Watt Digitally-Coupled Class D amplifier
Fuse Size:	3.25-amp 250-volt slow-blow fuse for 110-volt version and 2-amp 250-volt slow-blow fuse for the 240-volt version

Specifications subject to change without notice.

Visit us at www.definitivetech.com.

Limited Warranty: 5-Years for Drivers and Cabinets, 3-Years for Electronic Components

Definitive Technology warrants to the original retail purchaser only that this Definitive Technology Loudspeaker Product (the "Product") will be free from defects in materials and workmanship for a period of five (5) years covering the drivers and cabinets, and three (3) years for the electronic components from the date of the original purchase from a Definitive Technology Authorized Dealer. However, this warranty will automatically terminate prior to the expiration of five (5) years for the drivers and cabinets and three (3) years for the electronic components if the original retail purchaser sells or otherwise transfers the Product to any other party. The original retail purchaser shall hereinafter be referred to as "you." Defective Products must be shipped, together with proof of date of purchase, prepaid insured to the Authorized Dealer from whom you purchased the Product, or to the nearest factory service center. Product(s) must be shipped in the original shipping container or its equivalent; in any case the risk of loss or damage in transit is to be borne by you. If, upon examination at the Factory or a Definitive Technology Authorized Dealer, it is determined that the unit was defective in materials or workmanship at any time during this Warranty period, Definitive Technology or the Definitive Technology Authorized Dealer will, at its option, repair or replace this Product at no additional charge, except as set forth below. All replaced parts and Product(s) become the property of Definitive Technology. Product(s) replaced or repaired under this Warranty will be returned to you, within a reasonable time, freight collect.

This Warranty does not include service or parts to repair damage caused by accident, misuse, abuse, negligence, inadequate packing or shipping procedures, commercial use, voltage in excess of the rated maximum of the unit, cosmetic appearance of cabinetry not directly attributable to defects in materials or workmanship, or service, or repair or modification of the Product which has not been authorized by Definitive Technology. Definitive Technology makes no Warranty with respect to its Products purchased from dealers or outlets other than Definitive Technology Authorized Dealers. This Warranty is in lieu of all other expressed Warranties. If this Product is defective in material or workmanship as warranted above, your sole remedy shall be repair or replacement as provided above. In no event will Definitive Technology be liable to you for any incidental or consequential damages arising out of the use or inability to use the Product, even if Definitive Technology or a Definitive Technology Authorized Dealer has been advised of the possibility of such damages, or for any claim by any other party. Some states do not allow the exclusion or limitation of consequential damages, so the above limitation may not apply to you.

All implied warranties on the Product are limited to the duration of this expressed Warranty. Some states do not allow limitation on how long an implied Warranty lasts, so the above limitations may not apply to you. This Warranty gives you specific legal rights, and you also may have other rights which vary from state to state.



**This product complies with the essential
requirements of the EMC directive 89/336/EEC.**

Free Manuals Download Website

<http://myh66.com>

<http://usermanuals.us>

<http://www.somanuals.com>

<http://www.4manuals.cc>

<http://www.manual-lib.com>

<http://www.404manual.com>

<http://www.luxmanual.com>

<http://aubethermostatmanual.com>

Golf course search by state

<http://golfingnear.com>

Email search by domain

<http://emailbydomain.com>

Auto manuals search

<http://auto.somanuals.com>

TV manuals search

<http://tv.somanuals.com>