



Installation Instructions

CONTENTS

	Page
SAFETY CONSIDERATIONS	1
INTRODUCTION	1
INSTALLATION	1-27
Step 1 — Inspect Shipment	1
Step 2 — Rig and Place Unit	1
Step 3 — Piping Connections	9
• COOLER FLUID, VENT, AND DRAIN	
• BRINE UNITS	
• PREPARATION FOR YEAR-ROUND OPERATION	
• 30HXA REFRIGERANT PIPING	
• 30HXC CONDENSER CONNECTIONS	
• INSTALL PRESSURE RELIEF REFRIGERANT VENT PIPING	
Step 4 — Make Electrical Connections	14
• FIELD POWER CONNECTIONS	
• FIELD CONTROL POWER CONNECTIONS	
Step 5 — Install Accessories	26
• ELECTRICAL	
• 30HXA LOW-AMBIENT OPERATION	
• MINIMUM LOAD ACCESSORY	
• MISCELLANEOUS ACCESSORIES	
Step 6 — Leak Test Unit	26
• 30HXC UNITS	
• 30HXA UNITS	
Step 7 — Refrigerant Charge	26
• 30HXC UNITS	
• 30HXA UNITS	

SAFETY CONSIDERATIONS

Installing, starting up, and servicing this equipment can be hazardous due to system pressures, electrical components, and equipment location. Only trained, qualified installers and service mechanics should install, start up, and service this equipment.

When working on the equipment, observe precautions in the literature, and on tags, stickers, and labels attached to the equipment.

- Follow all safety codes.
- Wear safety glasses and work gloves.
- Use care in handling, rigging, and setting bulky equipment.

INTRODUCTION

These instructions cover installation of 30HX liquid chillers with electronic controls and units with factory-installed options (FIOPSs).

IMPORTANT: This equipment generates, uses, and can radiate radio frequency energy. If not installed and used in accordance with these instructions, this equipment may cause radio interference. The equipment has been tested and found to comply with the limits of a Class A computing device as defined by the FCC (Federal Communications Commission, U.S.A.) Regulations, Subpart J of Part 15, which are designed to provide reasonable protection against such interference when operated in a commercial environment.

INSTALLATION

Step 1 — Inspect Shipment — Inspect unit for damage upon arrival. If damage is found, file a claim with the shipping company right away. Do not store units in an area exposed to weather because of sensitive control mechanisms and electronic devices.

Locate unit indoors. When considering unit location, consult National Electrical Code (NEC, U.S.A.) and local code requirements. Allow sufficient space for wiring, piping, and service. Install unit in an area which will not be exposed to subfreezing weather. See Fig. 1-4 for clearance details.

Allow the following clearances for service access:

Front	3 ft (914 mm)
Rear	3 ft (914 mm)
Top	2 ft (610 mm)
Ends	tube removal at one (either) end; 3 ft (914 mm) at opposite end.

Be sure surface beneath the unit is level and is capable of supporting the operating weight of the unit. See Fig. 5 and Tables 1A and 1B for unit operating weights. If necessary, add supporting structure (steel beams or reinforced concrete slabs) to floor to transfer weight to nearest beams.

Step 2 — Rig and Place Unit

▲ CAUTION

Rig unit from the top heat exchanger only. Rigging from the bottom heat exchanger will cause the unit to be lifted unsafely. Personal injury or damage to the unit may occur.

Do not remove unit from skid until unit is in its final location. Rig from the rigging holes provided in the top heat exchanger. See Fig. 1-5 for rigging and center of gravity information. Lower the unit carefully onto the floor or roller. Push or pull only on the skid, **not the unit**. If the unit is moved on rollers, use a minimum of 3 evenly-spaced rollers.

Copy continued on page 9.

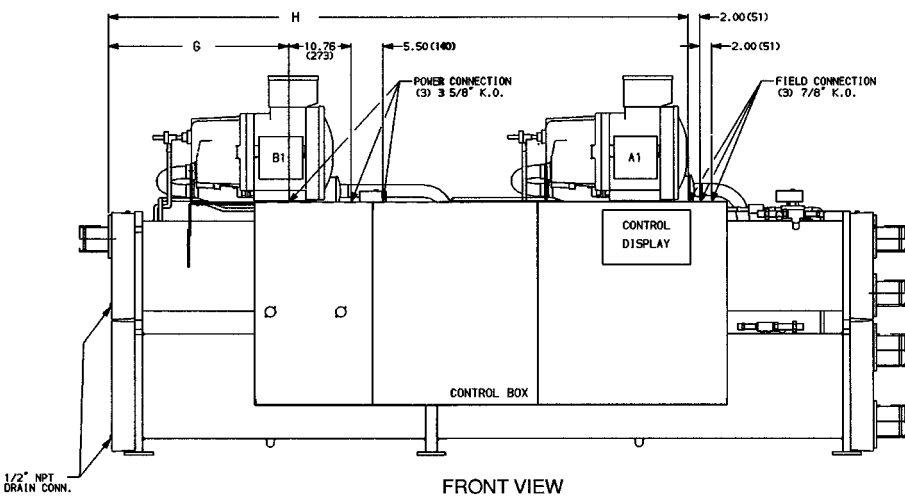

LEGEND
 K.O. — Knockout
 THK — Thick
 TYP — Typical

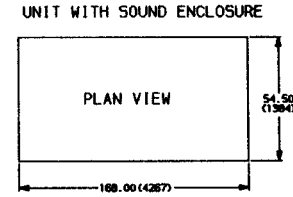

UNIT WITH SOUND ENCLOSURE
 LEAVE 36.00 (914) CLEARANCE AT SIDES OF SOUND ENCLOSURE FOR SERVICE.
 LEAVE POSTED CLEARANCE AT ONE END OF SOUND ENCLOSURE FOR TUBE REMOVAL.

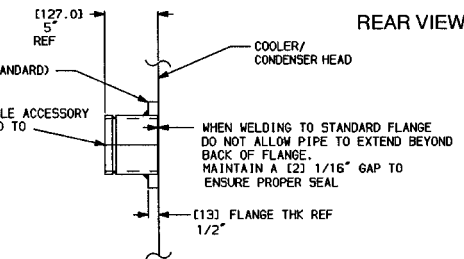
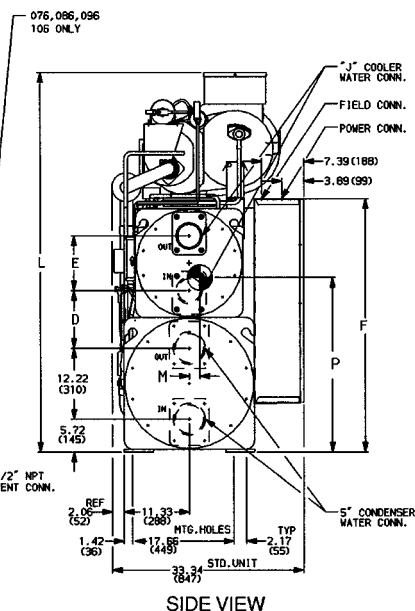
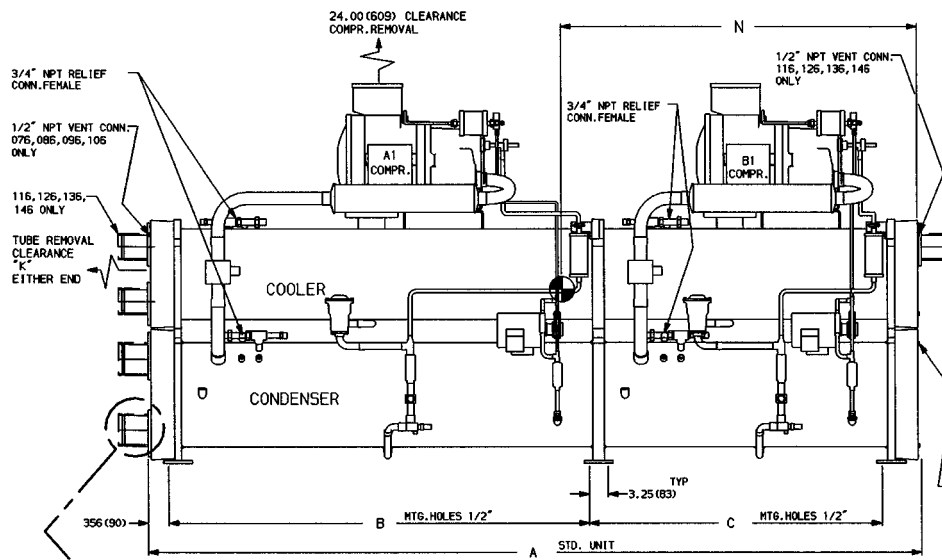

- NOTES:
1. Denotes center of gravity.
 2. Dimensions are in inches. Dimensions () are in millimeters.
 3. Recommended service clearance around unit (front, back, and one side) is 36" (914).

DIMENSIONS — in. (mm)

UNIT 30HXC	A	B	C	D	E	F	G	H	J	K	L	M	N	P
076	102.12 (2594)	45.87 (1165)	45.87 (1165)	9.87 (251)	9.36 (236)	43.50 (1105)	15.60 (396)	85.15 (2163)	4.00 (102)	95.00 (2413)	65.22 (1657)	1.90 (48)	47.00 (1194)	30.80 (782)
086	102.12 (2594)	45.87 (1165)	45.87 (1165)	9.87 (251)	9.36 (236)	43.50 (1105)	15.60 (396)	85.15 (2163)	4.00 (102)	95.00 (2413)	65.22 (1657)	1.90 (48)	47.00 (1194)	30.80 (782)
096	102.12 (2594)	37.63 (956)	54.12 (1375)	9.87 (251)	9.36 (236)	43.50 (1105)	15.60 (396)	85.15 (2163)	4.00 (102)	95.00 (2413)	65.22 (1657)	1.90 (48)	47.00 (1194)	30.80 (782)
106	102.12 (2594)	37.63 (956)	54.12 (1375)	10.47 (266)	10.28 (261)	45.50 (1156)	15.60 (396)	85.15 (2163)	5.00 (127)	95.00 (2413)	67.22 (1707)	1.90 (48)	47.00 (1194)	30.80 (782)
116	132.56 (3367)	72.12 (1832)	50.63 (1286)	9.87 (251)	9.36 (236)	43.50 (1105)	31.11 (790)	100.66 (2557)	4.00 (102)	126.00 (3200)	65.22 (1657)	1.70 (43)	62.20 (1580)	29.40 (747)
126	132.56 (3367)	72.12 (1832)	50.63 (1286)	9.87 (251)	9.36 (236)	43.50 (1105)	31.11 (790)	100.66 (2557)	4.00 (102)	126.00 (3200)	65.22 (1657)	1.70 (43)	62.20 (1580)	29.40 (747)
136	132.56 (3367)	72.12 (1832)	50.63 (1286)	9.87 (251)	9.36 (236)	43.50 (1105)	31.11 (790)	100.66 (2557)	4.00 (102)	126.00 (3200)	65.22 (1657)	1.70 (43)	62.20 (1580)	29.40 (747)
146	132.56 (3367)	72.12 (1832)	50.63 (1286)	9.87 (251)	9.36 (236)	43.50 (1105)	31.11 (790)	100.66 (2557)	4.00 (102)	126.00 (3200)	65.22 (1657)	1.70 (43)	62.20 (1580)	29.40 (747)

Fig. 1 — Base Unit Dimensions, 30HXC076-146 Units

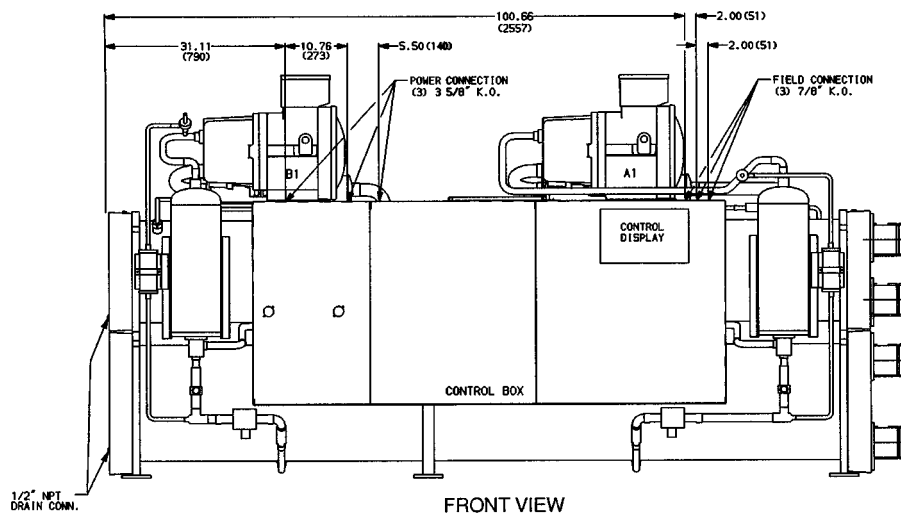

UNIT WITH SOUND ENCLOSURE

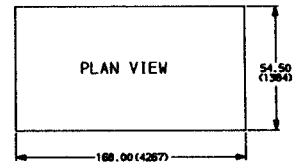

LEAVE 36.00 (914) CLEARANCE AT SIDES OF SOUND ENCLOSURE FOR SERVICE. LEAVE POSTED CLEARANCE AT ONE END OF SOUND ENCLOSURE FOR TUBE REMOVAL.

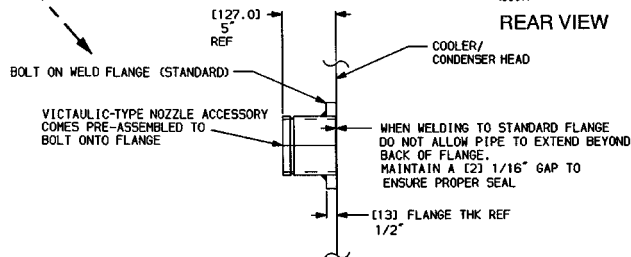
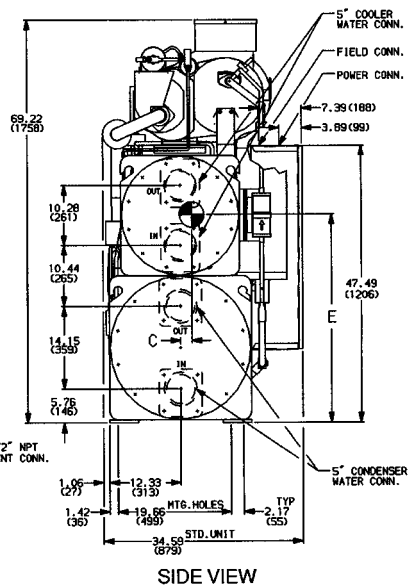
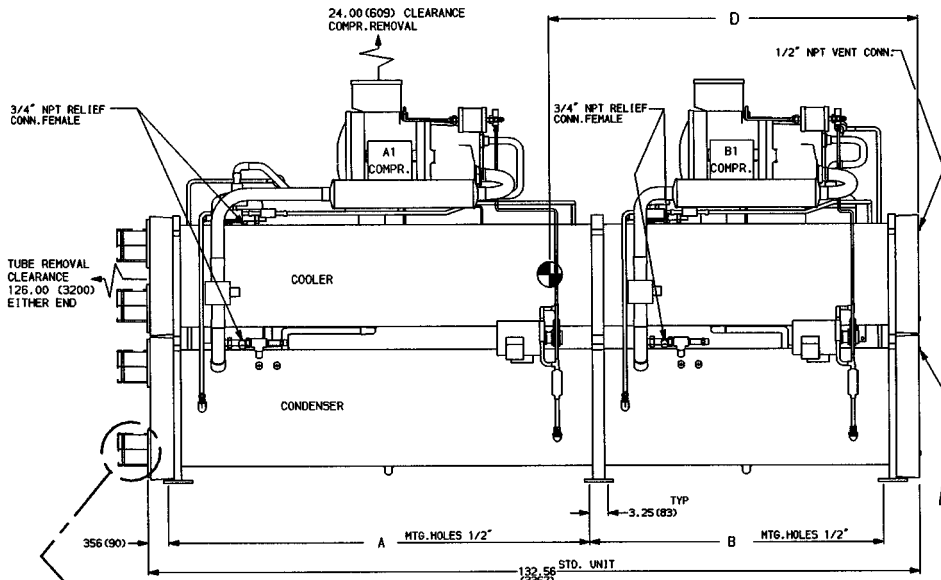

DETAIL "A"
NOZZLE ACCESSORY TYPICAL

DIMENSIONS — in. (mm)

UNIT	A	B	C	D	E
30HXC					
161	72.12 (1832)	50.63 (1286)	2.00 (51)	63.50 (1588)	31.00 (787)
171	61.37 (1559)	61.37 (1559)	2.00 (51)	63.50 (1588)	31.00 (787)
186	61.37 (1559)	61.37 (1559)	2.00 (51)	63.50 (1588)	31.00 (787)

NOTES:

- Denotes center of gravity.
- Dimensions are in inches. Dimensions () are in millimeters.
- Recommended service clearance around unit (front, back, and one side) is 36" (914).

LEGEND

- K.O. — Knockout
THK — Thick
TYP — Typical

Fig. 2 — Base Unit Dimensions, 30HXC161-186 Units

LEGEND

- K.O. — Knockout
- SAE — Society of Automotive Engineers, U.S.A.
- THK — Thick
- TYP — Typical

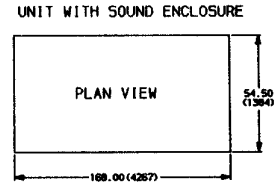
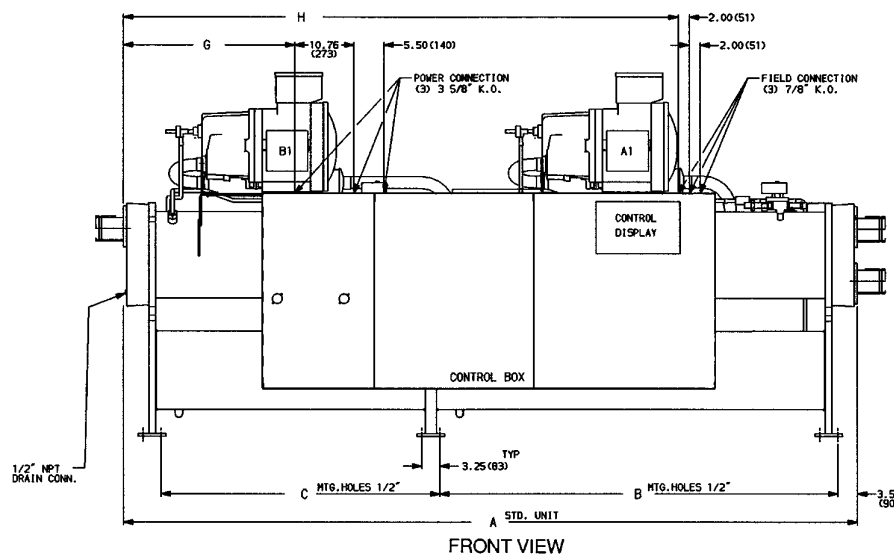

LEAVE 36.00 (914) CLEARANCE AT SIDES OF SOUND ENCLOSURE FOR SERVICE. LEAVE POSTED CLEARANCE AT ONE END OF SOUND ENCLOSURE FOR TUBE REMOVAL.

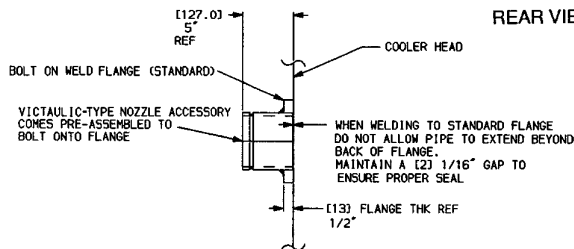
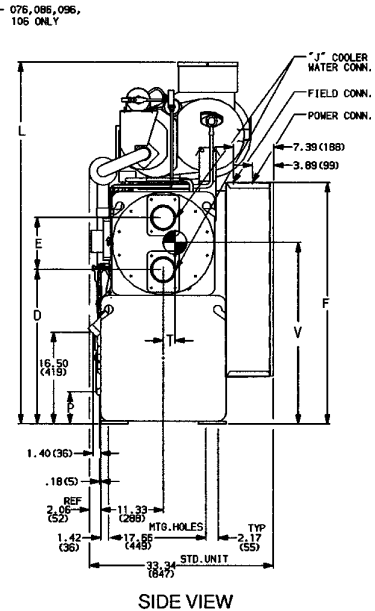
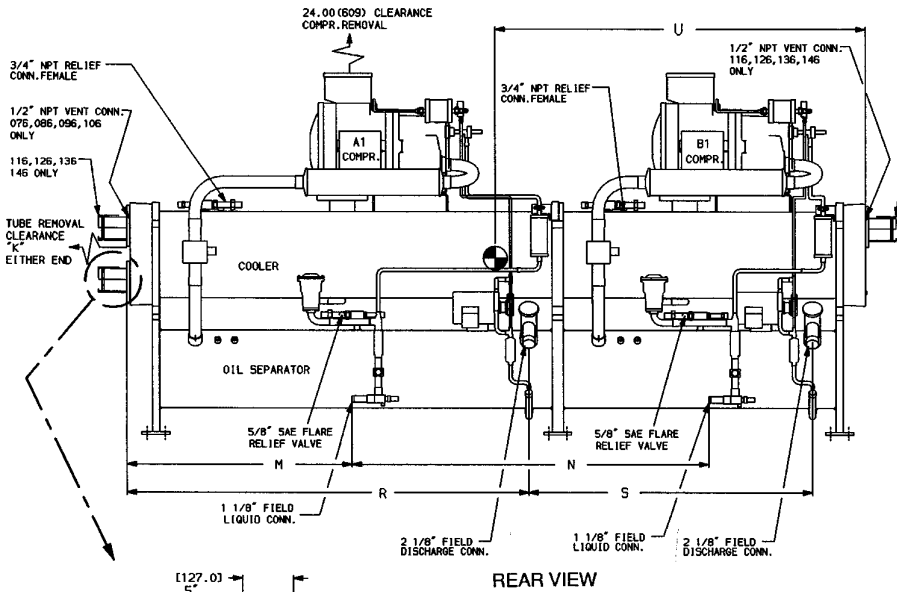

NOTES:

1. Denotes center of gravity.
2. Dimensions are in inches. Dimensions () are in millimeters.
3. Recommended service clearance around unit (front, back, and one side) is 36" (914).

DETAIL "A"
NOZZLE ACCESSORY TYPICAL

DIMENSIONS — in. (mm)

UNIT 30HXA	A	B	C	D	E	F	G	H	J	K	L	M	N	P	R	S	T	U	V
076	102.12 (2594)	45.87 (1165)	45.87 (1165)	27.81 (706)	9.36 (236)	43.50 (1105)	15.60 (396)	85.15 (2163)	4.00 (102)	95.00 (2413)	65.22 (1657)	13.93 (354)	59.48 (1511)	5.72 (145)	45.81 (1164)	46.25 (1175)	2.40 (61)	46.40 (1179)	35.00 (889)
086	102.12 (2594)	45.87 (1165)	45.87 (1165)	27.81 (706)	9.36 (236)	43.50 (1105)	15.60 (396)	85.15 (2163)	4.00 (102)	95.00 (2413)	65.22 (1657)	13.93 (354)	59.48 (1511)	5.72 (145)	45.81 (1164)	46.25 (1175)	2.40 (61)	46.40 (1179)	35.00 (889)
096	102.12 (2594)	37.63 (956)	54.12 (1375)	27.81 (706)	9.36 (236)	43.50 (1105)	15.60 (396)	85.15 (2163)	4.00 (102)	95.00 (2413)	65.22 (1657)	22.15 (563)	42.77 (1086)	5.72 (145)	54.06 (1373)	38.00 (965)	2.40 (61)	46.40 (1179)	35.00 (889)
106	102.12 (2594)	37.63 (956)	54.12 (1375)	28.41 (721)	10.28 (261)	45.50 (1156)	15.60 (396)	85.15 (2163)	5.00 (127)	95.00 (2413)	67.22 (1707)	22.15 (563)	42.77 (1086)	5.87 (149)	54.06 (1373)	38.00 (965)	2.40 (61)	46.40 (1179)	35.00 (889)
116	132.56 (3367)	72.12 (1832)	50.63 (1286)	27.81 (706)	9.36 (236)	43.50 (1105)	31.11 (790)	100.66 (2557)	4.00 (102)	126.00 (3200)	65.22 (1657)	40.16 (1020)	64.23 (1631)	5.72 (145)	72.06 (1830)	51.01 (1296)	2.30 (58)	61.00 (1549)	34.30 (871)
126	132.56 (3367)	72.12 (1832)	50.63 (1286)	27.81 (706)	9.36 (236)	43.50 (1105)	31.11 (790)	100.66 (2557)	4.00 (102)	126.00 (3200)	65.22 (1657)	40.16 (1020)	64.23 (1631)	5.72 (145)	72.06 (1830)	51.01 (1296)	2.30 (58)	61.00 (1549)	34.30 (871)
136	132.56 (3367)	72.12 (1832)	50.63 (1286)	27.81 (706)	9.36 (236)	43.50 (1105)	31.11 (790)	100.66 (2557)	4.00 (102)	126.00 (3200)	65.22 (1657)	40.16 (1020)	64.23 (1631)	5.72 (145)	72.06 (1830)	51.01 (1296)	2.30 (58)	61.00 (1549)	34.30 (871)
146	132.56 (3367)	72.12 (1832)	50.63 (1286)	27.81 (706)	9.36 (236)	43.50 (1105)	31.11 (790)	100.66 (2557)	4.00 (102)	126.00 (3200)	65.22 (1657)	40.16 (1020)	64.23 (1631)	5.72 (145)	72.06 (1830)	51.01 (1296)	2.30 (58)	61.00 (1549)	34.30 (871)

Fig. 3 — Base Unit Dimensions, 30HXA076-146 Units

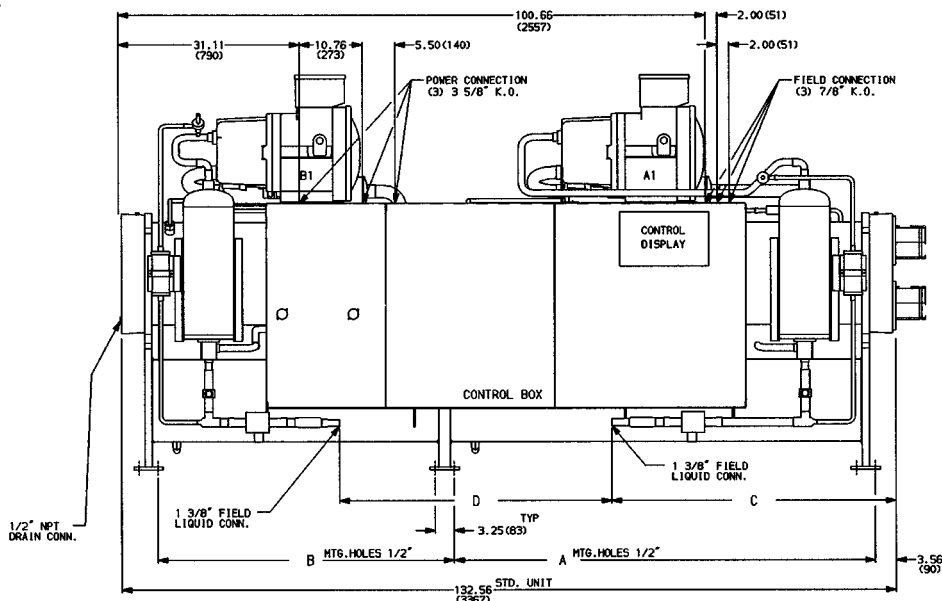

LEGEND
 K.O. — Knockout
 SAE — Society of Automotive Engineers, U.S.A.
 THK — Thick
 TYP — Typical

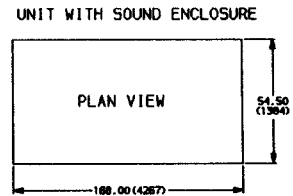

LEAVE 36.00 (914) CLEARANCE AT SIDES OF SOUND ENCLOSURE FOR SERVICE. LEAVE POSTED CLEARANCE AT ONE END OF SOUND ENCLOSURE FOR TUBE REMOVAL.

FRONT VIEW

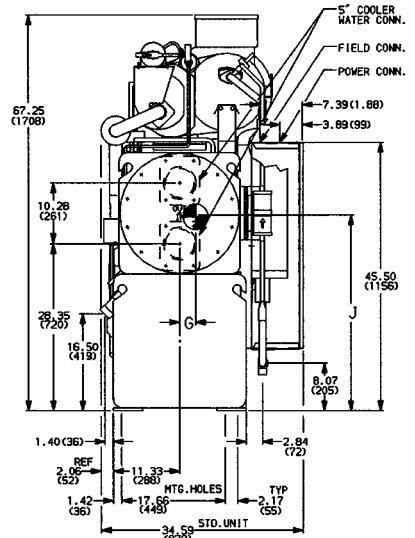
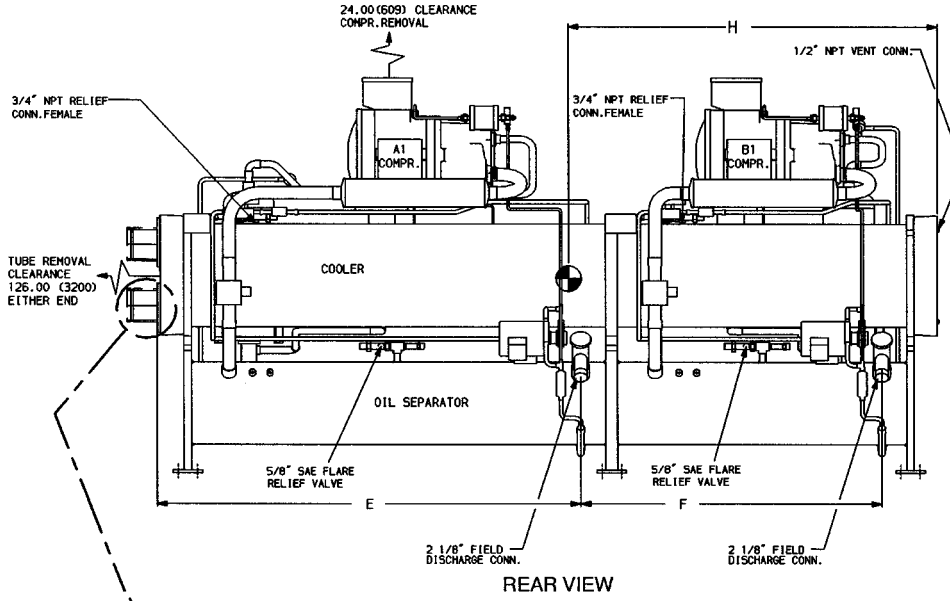

REAR VIEW

SIDE VIEW

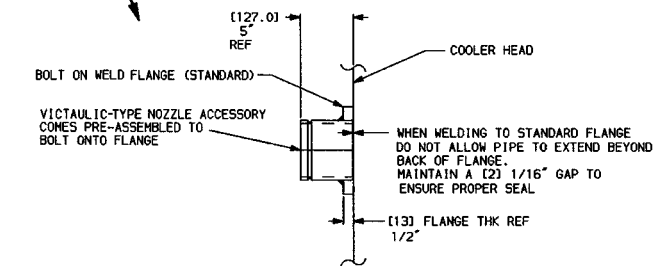

DETAIL "A"
NOZZLE ACCESSORY TYPICAL

- NOTES:**
1. Denotes center of gravity.
 2. Dimensions are in inches. Dimensions () are in millimeters.
 3. Recommended service clearance around unit (front, back, and one side) is 36" (914).

DIMENSIONS — in. (mm)

UNIT 30HXA	A	B	C	D	E	F	G	H	J
161	72.12 (1832)	50.63 (1386)	48.56 (1233)	46.62 (1184)	72.06 (1830)	51.00 (1295)	2.70 (69)	62.50 (1588)	35.20 (894)
171	61.37 (1559)	61.37 (1559)	43.25 (1099)	46.62 (1184)	61.31 (1572)	61.75 (1568)	2.70 (69)	62.50 (1588)	35.20 (894)
186	61.37 (1559)	61.37 (1559)	43.25 (1099)	46.62 (1184)	61.31 (1572)	61.75 (1568)	2.70 (69)	62.50 (1588)	35.20 (894)

Fig. 4 — Base Unit Dimensions, 30HXA161-186 Units

WEIGHT DISTRIBUTION

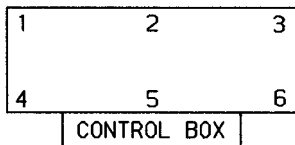

WEIGHT DISTRIBUTION AT EACH MOUNTING PLATE,
30HXC UNITS — Lb (Kg)

UNIT 30HXC	MOUNTING PLATE NO.					
	1	2	3	4	5	6
076	738 (335)	943 (428)	595 (270)	1110 (503)	1418 (643)	896 (406)
086	738 (335)	947 (430)	597 (271)	1112 (504)	1427 (647)	902 (409)
096	686 (311)	968 (439)	693 (314)	1027 (466)	1447 (656)	1034 (469)
106	730 (331)	1028 (466)	744 (337)	1073 (487)	1510 (685)	1092 (495)
116	728 (330)	1114 (505)	777 (352)	1053 (478)	1615 (733)	1127 (511)
126	738 (335)	1127 (511)	780 (354)	1061 (481)	1628 (738)	1131 (513)
136	758 (344)	1176 (533)	811 (368)	1083 (491)	1689 (766)	1171 (531)
146	763 (346)	1182 (536)	815 (370)	1085 (492)	1697 (770)	1172 (532)
161	817 (371)	1272 (577)	908 (412)	1219 (553)	1890 (857)	1346 (610)
171	936 (425)	1318 (598)	840 (381)	1379 (626)	1946 (883)	1241 (563)
186	962 (436)	1361 (617)	860 (390)	1410 (640)	1996 (905)	1265 (574)

WEIGHT DISTRIBUTION AT EACH MOUNTING PLATE,
30HXA UNITS — Lb (Kg)

UNIT 30HXA	MOUNTING PLATE NO.					
	1	2	3	4	5	6
076	555 (252)	793 (360)	418 (190)	926 (420)	1326 (601)	699 (317)
086	555 (252)	798 (362)	418 (190)	928 (421)	1340 (608)	705 (320)
096	509 (231)	808 (367)	493 (224)	848 (385)	1350 (612)	827 (375)
106	555 (252)	869 (394)	541 (245)	896 (406)	1410 (640)	880 (399)
116	530 (240)	895 (406)	540 (245)	855 (388)	1456 (660)	887 (402)
126	540 (245)	905 (410)	541 (245)	864 (392)	1468 (666)	887 (402)
136	548 (249)	926 (420)	555 (252)	8743 (396)	1498 (679)	908 (412)
146	551 (250)	930 (422)	555 (252)	883 (400)	1506 (683)	908 (412)
161	560 (254)	965 (438)	598 (271)	954 (433)	1650 (748)	1025 (465)
171	627 (284)	968 (439)	534 (242)	1072 (486)	1658 (752)	918 (416)
186	648 (294)	1004 (455)	552 (250)	1110 (504)	1703 (772)	939 (426)

NOTE: See Fig. 1-4 for center of gravity details.

Fig. 5 — Rigging Information

Table 1A — Physical Data, English

UNIT SIZE	076	086	096	106	116	126	136	146	161	171	186
UNIT WEIGHT (lb)											
Fluid Cooled (HXC)	5700	5723	5855	6177	6415	6465	6688	6718	7452	7660	7854
Condenserless (HXA)	4717	4744	4835	5151	5162	5205	5308	5333	5752	5777	5946
COMPRESSORS	Semi-Hermetic, Twin Screw										
Quantity	2	2	2	2	2	2	2	2	2	2	2
Nominal Capacity per Compressor (tons)	39/39	46/39	56/39	66/39	66/46	66/56	80/56	80/66	80/56	66/80	80/80
Economizer	No	No	No	No	No	No	No	No	Yes	Yes	Yes
No. Capacity Steps											
Standard	6	6	6	6	6	6	6	6	6	6	6
Optional (maximum)	8	8	8	8	8	8	8	8	8	8	8
Minimum Step Capacity (%)											
Standard	20	20	20	20	20	20	20	20	20	20	20
Optional	10	10	10	10	10	10	10	10	10	10	10
REFRIGERANT TYPE	R-134a										
Charge* (lb)											
Circuit A/Circuit B	55/55	66/55	79/55	95/55	95/66	95/79	114/79	114/95	130/90	109/130	130/130
COOLER TYPE	Shell and Tube with Enhanced Copper Tubes										
Part No. 10HX400-	001	001	002	010	007	007	006	006	104	012	013
Net Fluid Volume (gal)	17.0	17.0	19.0	22.6	21.4	21.4	24.0	24.0	28.5	28.5	33.4
Maximum Refrigerant Pressure (psig)	220	220	220	220	220	220	220	220	220	220	220
Maximum Fluid-Side Pressure (psig)	300	300	300	300	300	300	300	300	300	300	300
Fluid Connections (in.)	Steel Weld Couplings										
Inlet and Outlet	4	4	4	5	4	4	4	4	5	5	5
Drain (NPT)	1/2	1/2	1/2	1/2	1/2	1/2	1/2	1/2	1/2	1/2	1/2
30HXA OIL SEPARATOR											
Part No. 09RX400-	007	007	008	008	009	009	009	009	009	010	010
Maximum Refrigerant Pressure (psig)	320	320	320	320	320	320	320	320	320	320	320
Refrigerant Connections (in.)											
Discharge	2 1/8	2 1/8	2 1/8	2 1/8	2 1/8	2 1/8	2 1/8	2 1/8	2 1/8	2 1/8	2 1/8
Liquid	1 1/8	1 1/8	1 1/8	1 1/8	1 1/8	1 1/8	1 1/8	1 1/8	1 3/8	1 3/8	1 3/8
CONDENSER (HXC)	Shell and Tube with Enhanced Copper Tubes										
Part No. 09RX400-	001	001	002	002	003	003	004	004	005	006	006
Net Fluid Volume (gal)	16.8	16.8	18.3	18.3	23.9	23.9	27.5	27.5	30.6	37.6	37.6
Maximum Refrigerant Pressure (psig)	220	220	220	220	220	220	220	220	220	220	220
Maximum Water-Side Pressure (psig)	300	300	300	300	300	300	300	300	300	300	300
Water Connections (in.)	Steel Weld Couplings										
Inlet and Outlet	5	5	5	5	5	5	5	5	5	5	5
Drain (NPT)	1/2	1/2	1/2	1/2	1/2	1/2	1/2	1/2	1/2	1/2	1/2

*Charges listed are for 30HXC units. The 30HXA units are shipped with a holding charge only.

Table 1B — Physical Data, SI

UNIT SIZE	076	086	096	106	116	126	136	146	161	171	186
UNIT WEIGHT (Kg)											
Fluid Cooled (HXC)	2586	2596	2656	2802	2910	2933	3034	3047	3380	3476	3563
Condenserless (HXA)	2140	2152	2193	2336	2341	2361	2408	2419	2609	2620	2697
COMPRESSORS	Semi-Hermetic, Twin Screw										
Quantity	2	2	2	2	2	2	2	2	2	2	2
Nominal Capacity per Compressor (kW)	137/137	162/137	197/137	232/137	232/137	232/197	281/197	281/232	281/197	232/281	281/281
Economizer	No	No	No	No	No	No	No	No	Yes	Yes	Yes
No. Capacity Steps											
Standard	6	6	6	6	6	6	6	6	6	6	6
Optional (maximum)	8	8	8	8	8	8	8	8	8	8	8
Minimum Step Capacity (%)											
Standard	20	20	20	20	20	20	20	20	20	20	20
Optional	10	10	10	10	10	10	10	10	10	10	10
REFRIGERANT TYPE	R-134a										
Charge* (Kg)	24.9/	29.9/	35.8/	43.1/	43.1/	43.1/	51.7/	51.7/	59.0/	49.4/	59.0/
Circuit A/Circuit B	24.9	24.9	24.9	24.9	29.9	35.8	35.8	43.1	40.8	59.0	59.0
COOLER TYPE	Shell and Tube with Enhanced Copper Tubes										
Part No. 10HX400-	001	001	002	010	007	007	006	006	104	012	013
Net Fluid Volume (L)	64.3	64.3	71.9	85.5	81.0	81.0	90.8	90.8	107.9	107.9	126.4
Maximum Refrigerant Pressure (kPa)	1517	1517	1517	1517	1517	1517	1517	1517	1517	1517	1517
Maximum Fluid-Side Pressure (kPa)	2068	2068	2068	2068	2068	2068	2068	2068	2068	2068	2068
Fluid Connections (in.)	Steel Weld Couplings										
Inlet and Outlet	4	4	4	5	4	4	4	4	5	5	5
Drain (NPT)	1/2	1/2	1/2	1/2	1/2	1/2	1/2	1/2	1/2	1/2	1/2
30HXA OIL SEPARATOR	Steel Weld Couplings										
Part No. 09RX400-	007	007	008	008	009	009	009	009	009	010	010
Maximum Refrigerant Pressure (kPa)	2205	2205	2205	2205	2205	2205	2205	2205	2205	2205	2205
Refrigerant Connections (in.)											
Discharge	2 1/8	2 1/8	2 1/8	2 1/8	2 1/8	2 1/8	2 1/8	2 1/8	2 1/8	2 1/8	2 1/8
Liquid	1 1/8	1 1/8	1 1/8	1 1/8	1 1/8	1 1/8	1 1/8	1 1/8	1 3/8	1 3/8	1 3/8
CONDENSER (HXC)	Shell and Tube with Enhanced Copper Tubes										
Part No. 09RX400-	001	001	002	002	003	003	004	004	105	006	006
Net Fluid Volume (L)	63.6	63.6	69.3	69.3	90.5	90.5	104.1	104.1	115.8	142.3	142.3
Maximum Refrigerant Pressure (kPa)	1517	1517	1517	1517	1517	1517	1517	1517	1517	1517	1517
Maximum Water-Side Pressure (kPa)	2068	2068	2068	2068	2068	2068	2068	2068	2068	2068	2068
Water Connections (in.)	Steel Weld Couplings										
Inlet and Outlet	5	5	5	5	5	5	5	5	5	5	5
Drain (NPT)	1/2	1/2	1/2	1/2	1/2	1/2	1/2	1/2	1/2	1/2	1/2

*Charges listed are for 30HXC units. The 30HXA units are shipped with a holding charge only.

IMPORTANT: Some of the unit skids are larger than standard door openings. Be sure that the path to the unit's final destination is wide enough to accommodate unit shipping skid. Remove the skid if necessary. If skid is removed and rollers are used, attach rollers to unit tube sheets while moving unit.

Areas where unit mounting points will be located must be level to within 1/16 in. per ft (1 mm per m) along the long axis of the unit. Once unit is in place and level, bolt unit to the floor. Use isolation pads under the unit to aid in vibration isolation as required.

Step 3 — Piping Connections — See Fig. 6 and 7 for typical piping applications.

COOLER FLUID, VENT, AND DRAIN — The inlet (return) fluid connection is always the lower of the 2 cooler connections. See Fig. 6 for locations. A screen strainer with a minimum of 20 mesh should be installed ahead of the cooler inlet to prevent debris from damaging internal tubes of the cooler. Outlet (supply) fluid connection is the upper connection of the 2 cooler connections.

The cooler has weld flanges to connect the field-supplied piping. Plan the piping arrangement in accordance with good piping practices and so that the piping does not cross in front of the cooler head. Use flexible connections on cooler piping to reduce vibration transmission. Offset the piping to permit removal of the cooler head for maintenance. Install pipe hangers where needed. Make sure no weight or stress is placed on the water nozzle.

To install cooler piping:

1. Remove bolts on weld flanges, and remove flanges from cooler fluid heads.

CAUTION

Remove the weld flanges before welding piping to the flanges. Refer to Fig. 1-4 for weld flange locations. Failure to remove the flanges may damage the sensors and insulation.

2. To keep debris from entering the heat exchanger during shipping and storage, the gaskets between the weld flanges and the fluid heads do not have holes cut into them. The gaskets have perforations where the holes are to be cut. Carefully cut a hole along the designated perforations.

IMPORTANT: Be sure to remove flanges and cut holes in the gaskets between the flanges and the fluid heads as indicated.

3. Apply a thin coat of oil to both sides of each gasket to help ensure a good seal, and reattach each gasket to each fluid head.
4. Weld the field-supplied piping to the weld flanges.
5. Bolt the weld flanges back onto their respective fluid heads.

IMPORTANT: When bolting the weld flanges to the fluid heads, be sure to locate the flange such that the hole in each flange lines up completely with the hole in each fluid head. If installed incorrectly, part of the hole in the fluid head will be blocked off. This will result in impaired fluid flow in high pressure drop applications.

CAUTION

Tighten all cooler head bolts to 250 ft-lb (339 N-m) before filling system with water (or brine).

6. Install field-supplied differential flow switches in the cooler piping for protection against loss of flow. The differential flow switches must be installed on top of the pipe in a horizontal run and should be at least 5 pipe diameters from any bend. Install the low-pressure differential flow switch into the outlet line piping, and install the high-pressure differential flow switch into the inlet line piping as shown in Fig. 8.
7. Provide openings in fluid piping for pressure gages and thermometers (if used). These openings should be 5 to 10 pipe diameters from the unit water nozzles. For thorough mixing and temperature stabilization, wells in the leaving fluid pipe should extend at least 2 in. (50 mm) into the pipe.

Accessory Victaulic-type connections are available. Follow the connection directions provided with the accessory.

Although cooler has an air vent, it is recommended that a field-supplied air vent be installed in the system to facilitate servicing. Field-supplied shut-off and balancing valves should also be installed to facilitate servicing and flow balancing. Locate valves in return and supply fluid lines as close to the chiller as possible. Locate air vent at highest point of the cooler fluid system. See Fig. 6.

Provide drain connections at all low points to permit complete drainage of the system.

BRINE UNITS — Special factory modifications to the units are required to allow them to operate at fluid temperatures less than 34 F (1.1 C). Be sure that the fluid has sufficient inhibited ethylene glycol or other suitable corrosion-resistant antifreeze solution to prevent cooler freeze up.

PREPARATION FOR YEAR-ROUND OPERATION — In areas where the piping or unit is exposed to 32 F (0 °C) or lower ambient temperatures, freeze-up protection is recommended using inhibited ethylene glycol or other suitable corrosion-resistant antifreeze solution and electric heater tapes. Heater tapes should have a rating for area ambient temperatures and be covered with a suitable thickness of closed-cell insulation. Route power for the heater tapes from a separately-fused disconnect. Mount the disconnect within sight from the unit per local or NEC codes. Identify disconnect as heater tape power source with warning that power must not be turned off except when servicing unit.

Fill the fluid loop with water (or brine) and a corrosion-resistant inhibitor suitable for the water of the area. Consult the local water authority for characteristics of area water and a recommended inhibitor for the cooler fluid loop. It is recommended that once the cooler water lines have been installed and leak checked that the cooler heads be insulated with a suitable thickness of closed-cell insulation. This will minimize the amount of condensation that will form on the cooler heads.

IMPORTANT: Before starting the unit, be sure all of the air has been purged from the system.

A drain connection is located at the bottom of the cooler head. See Fig. 3 and 4 for connection location. Install shut-off valves to the drain line before filling the system with fluid.

- NOTES:
1. Wiring and piping shown are for general point-of-connection only and are not intended to show details for specific installation. Certified field wiring and dimensional diagrams are available upon request. The 30HXA and HXC units should be installed using certified drawings.
 2. All wiring must comply with applicable codes.
 3. Refer to Carrier System Design Manual for details regarding piping techniques.
 4. Piping, wiring, switches, valves, vent, gages, strainers, drain, and vibration isolation are all field supplied.

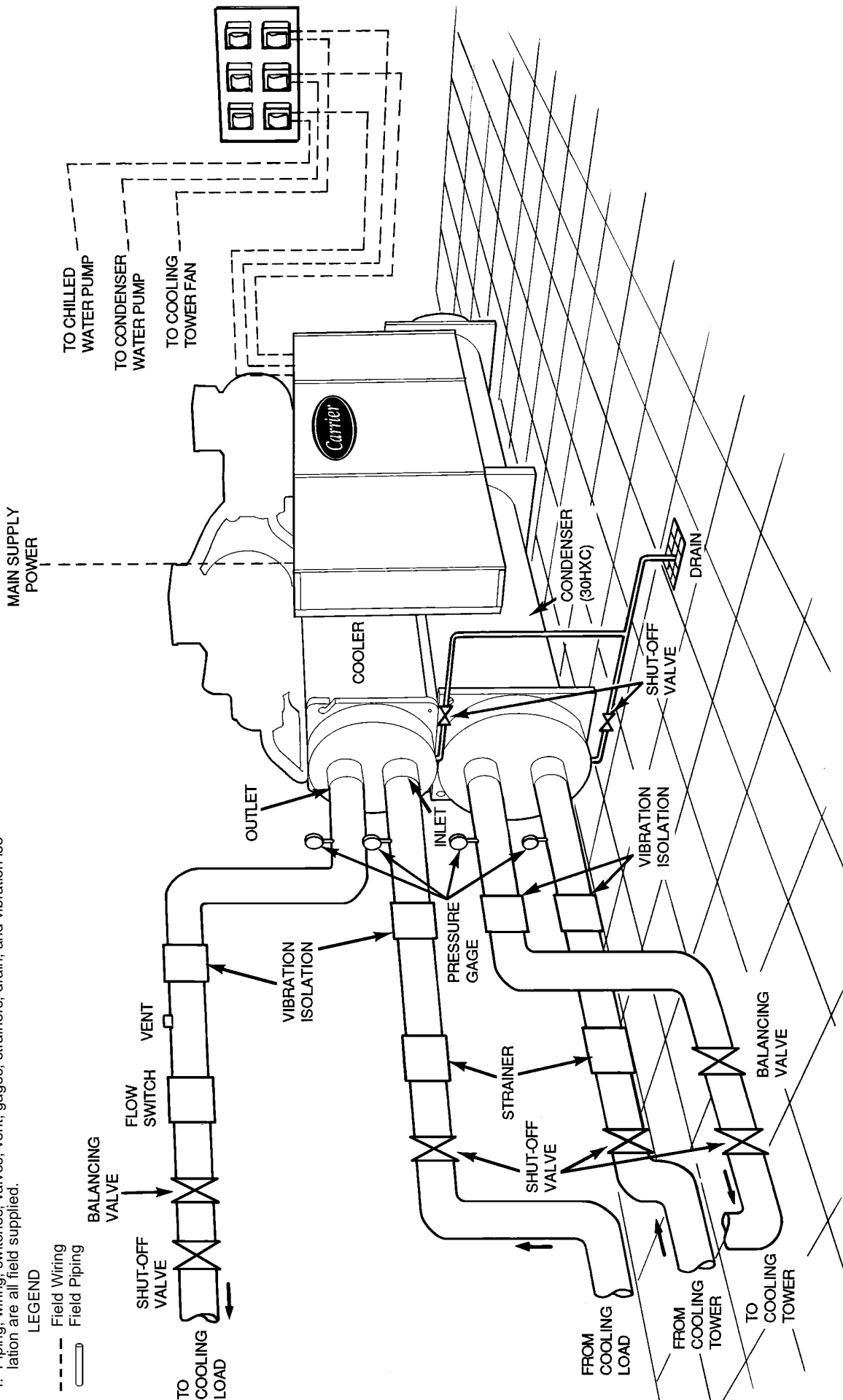

Fig. 6 — Typical Cooler (30HXA, HXC) and Condenser (30HXC Only) Piping and Wiring

NOTES:

1. Piping shown is for general point-of-connection only and is not intended to show details for a specific installation. Certified field wiring and dimensional drawings are available upon request. The 30HXA units should be installed using certified drawings.
2. Refer to Carrier System Design Manual for details regarding piping techniques.
3. Piping and pressure relief devices are field supplied.
4. Vent pipes properly per local codes.

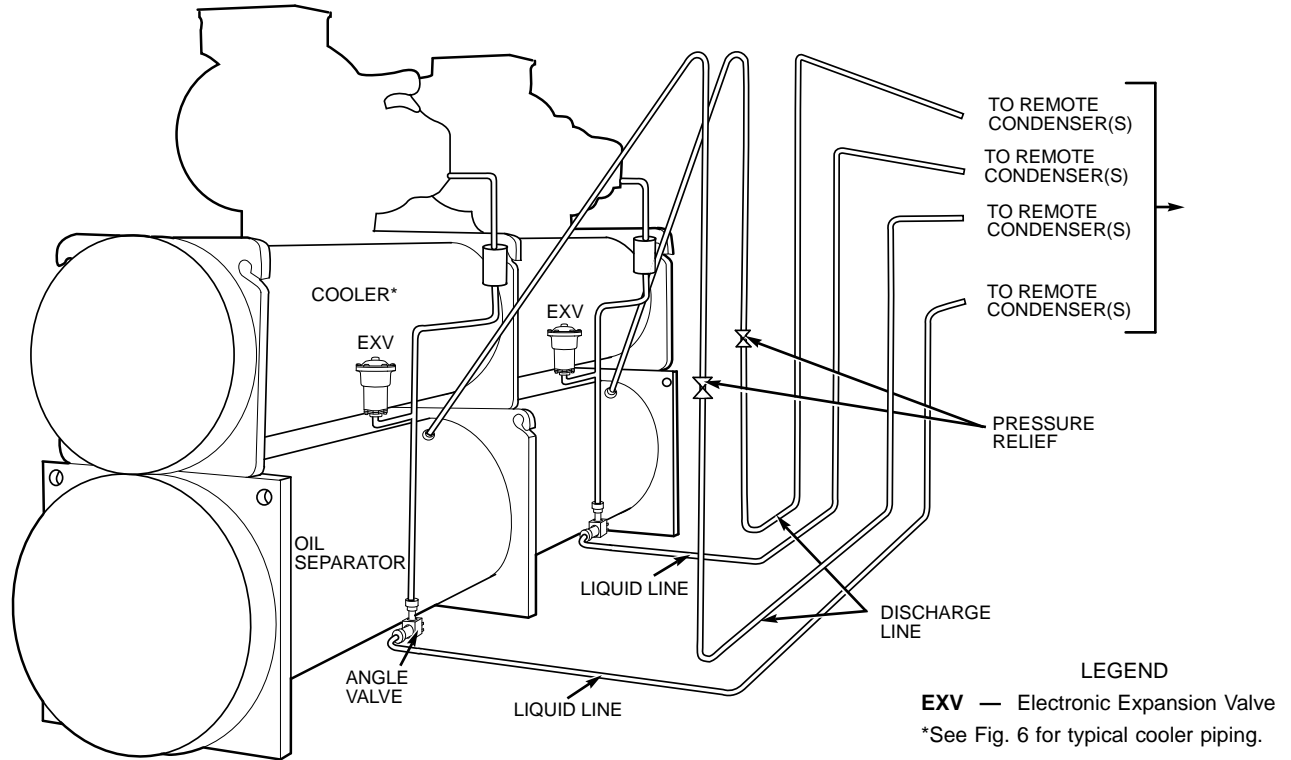

Fig. 7 — Typical 30HXA Refrigerant Piping to Remote Condenser

30HXA REFRIGERANT PIPING (See Fig. 7) — Take care when running the refrigerant piping from the 30HXA unit to the remote condenser(s) to avoid excessive pressure drops. The pressure drop using R-134a refrigerant is different than when using R-22 refrigerant. See Tables 2 and 3 for an example for a 2 F (1.1 C) pressure drop in saturated temperature in the discharge (hot gas) line and liquid line, respectively. Refer to Fig. 9 and 10 for line sizing information for the discharge and liquid lines for 30HXA (R-134a) units.

Table 2 — Discharge Line 2 F (1.1 C) Drop in Saturated Temperature Example

SATURATED DISCHARGE TEMP		PRESSURE			
		R-134a		R-22	
F	C	Psig	kPa	Psig	kPa
126	52.2	187.5	1293	281.6	1942
124	51.1	182.0	1255	274.3	1891
Δ PRESSURE		5.5	38	7.3	51

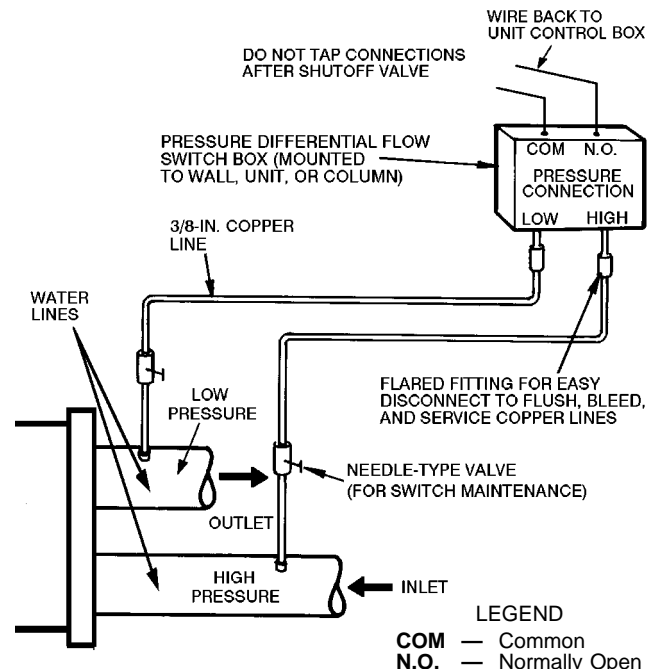
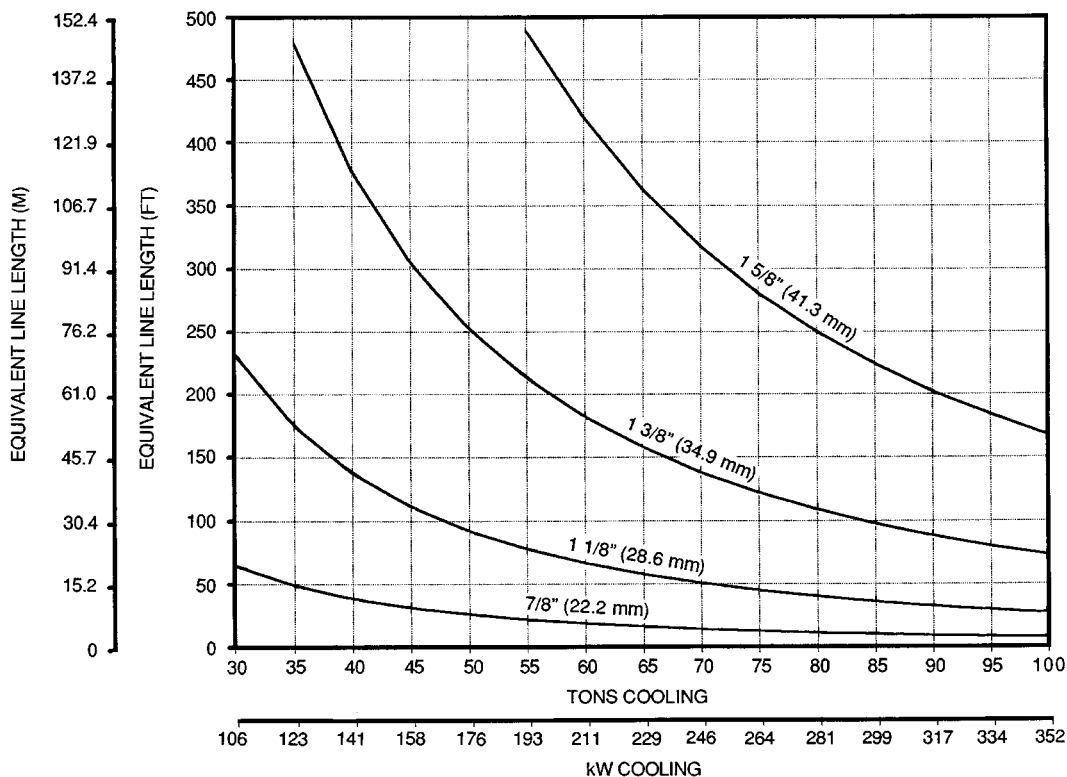

Fig. 8 — Differential Flow Switch



NOTES:

1. Values are for a 2° F pressure drop at 125 F (51.7 C) saturated discharge temperature, 120 F (48.9 C) saturated condensing temperature, and 105 F (40.6 C) liquid refrigerant temperature.
2. Size each circuit separately.

Fig. 9 — R-134a Liquid Line Sizing, 30HXA Units

Table 3 — Liquid Line 2 F (1.1 C) Drop in Saturated Temperature Example

SATURATED LIQUID TEMP		PRESSURE			
		R-134a		R-22	
F	C	Psig	kPa	Psig	kPa
100	37.7	124.3	857	195.9	1351
98	36.7	120.1	828	190.2	1311
Δ PRESSURE		4.2	29	5.7	40

IMPORTANT: There is a Schrader-type fitting in each of the two ¼-in. fittings. These Schrader-type fittings **MUST BE REMOVED** before running the line.

Discharge lines should be looped above the compressors to avoid having charge flowing back to the oil separator and compressor during unit shutdown. Wrap back-pressure valve when brazing discharge line to avoid damaging the valve.

It is recommended that field-supplied pressure relief valves be installed in each discharge line. Most local codes require that the relief valves be vented directly to the outdoors. The vent must not be smaller than the relief valve outlet, and the pressure setting should be 320 psig (2205 kPa).

Run a field-supplied ¼-in. (6.4 mm) copper line between the back-pressure valve on the oil separator (bottom pressure vessel) to the fitting on the refrigerant line entering the economizer port of the compressor to measure oil pressure differential. See Fig. 11. The back-pressure valve and the fitting on the refrigerant line have a ¼-in. flare fitting for making this connection. The flare nut is field supplied.

The 30HXA units are shipped from the factory with a holding charge of R-134a. Before opening the refrigerant system, relieve system pressure and recover system refrigerant through the charging valve on the cooler.

30HXC CONDENSER CONNECTIONS — The inlet fluid connection is always the lower of the 2 condenser connections. It is recommended that a screen strainer with a minimum of 20 mesh be installed ahead of the condenser inlet to prevent debris from damaging the internal condenser tubes.

The outlet water connection is the upper connection of the 2 connections. The condenser has weld couplings to connect field-supplied piping. Plan the piping arrangement in accordance with good piping practices and so that the piping does not cross in front of the condenser head. Use flexible connections on the condenser piping to reduce vibration transmission. Offset the piping to permit condenser head removal for maintenance purposes. Install pipe hangers where needed. Make sure no weight or stress is placed on the water nozzle.

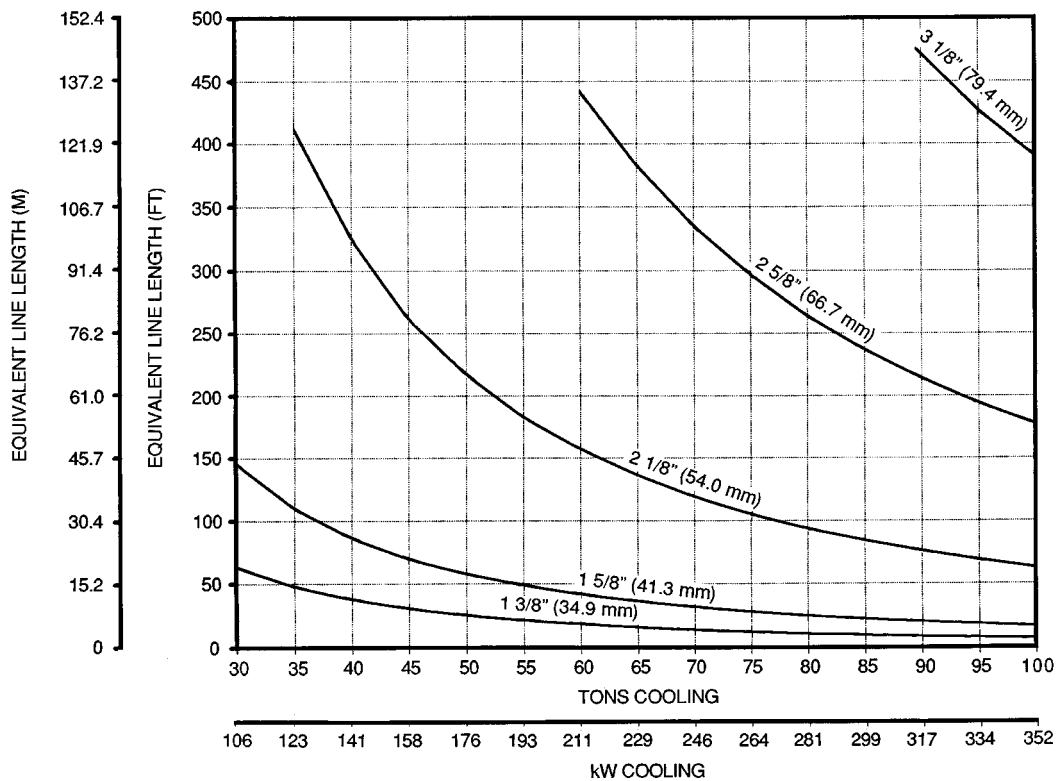

NOTES:

1. Values are for a 2° F pressure drop at 125 F (51.7 C) saturated discharge temperature, 120 F (48.9 C) saturated condensing temperature, and 105 F (40.6 C) liquid refrigerant temperature.
2. Size each circuit separately.

Fig. 10 — R-134a Discharge Line Sizing, 30HXA Units

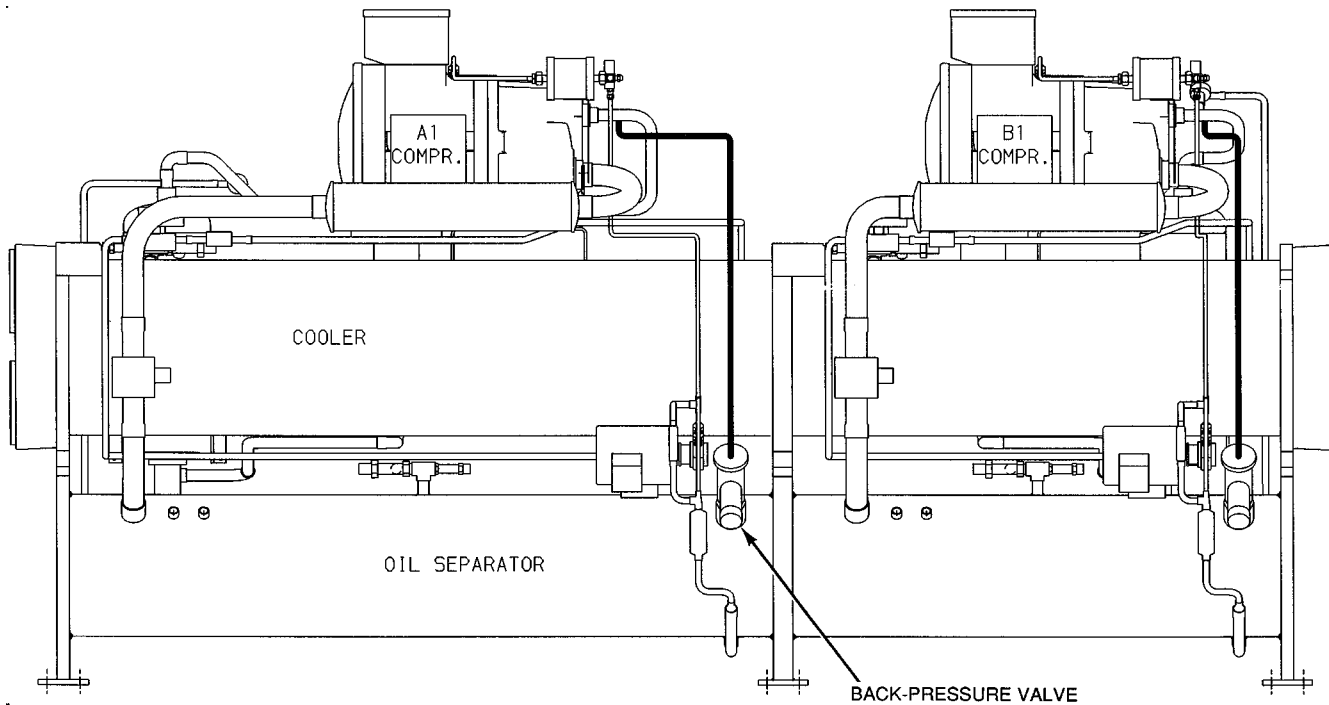

Fig. 11 — Field-Supplied 1/4-in. Copper Tube, 30HXA Units

To install condenser piping:

1. Remove bolts on weld flanges, and remove flanges from condenser water heads.

⚠ CAUTION

Remove the weld flanges before welding piping to the flanges. Refer to Fig. 1 and 2 for weld flange locations. Failure to remove the flanges may damage the sensors and insulation.

2. To keep debris from entering the heat exchanger during shipping and storage, the gaskets between the weld flanges and the water heads do not have holes cut into them. The gaskets have perforations where the holes are to be cut. Carefully cut a hole along the designated perforations.

IMPORTANT: Be sure to remove flanges and cut holes in the gaskets between the flanges and the water heads as indicated.

3. Apply a thin coat of oil to both sides of each gasket to help ensure a good seal, and reattach each gasket to each water head.
4. Weld the field-supplied piping to the weld flanges.
5. Bolt the weld flanges back onto their respective water heads.

IMPORTANT: When bolting the weld flanges to the water heads, be sure to locate the flange such that the hole in each flange lines up completely with the hole in each water head. If installed incorrectly, part of the hole in the water head will be blocked off. This will result in impaired water flow in high pressure drop applications.

Provide openings in water piping for pressure gages and thermometers (if used). These openings should be 5 to 10 pipe diameters from the unit water nozzles. For thorough mixing and temperature stabilization, wells in the leaving water pipe should extend at least 2 in. (50 mm) into the pipe.

Accessory Victaulic-type connections and condenser-water thermistors are available. Follow the connection directions as provided with the accessory. If accessory differential pressure switch, water flow switch, or condenser water thermistor is to be installed, install the proper fittings into the condenser water lines before water is connected.

Although condenser has an air vent, it is recommended that a field-supplied air vent be installed in the system to facilitate servicing. Field-supplied shut-off and balancing valves should also be installed to facilitate servicing and flow balancing. Locate valves in inlet and outlet lines as close to the chiller as possible. Locate air vents at the highest point of the system loop. See Fig. 6.

Provide drain connections at all low points in the loop to permit complete system drainage.

For installations where entering condensing water temperature could be below 70 F (21 C), a field-supplied leaving water temperature regulating valve is required. Operation below 70 F (21.1 C) without this valve may cause the unit to shut down on low oil pressure alarms.

NOTE: This valve should be a temperature-controlled valve (DO NOT USE a pressure-controlled valve) which controls to 80 F (26.7 C) leaving water temperature. Be sure to add a bleed line between the entering and leaving water lines.

INSTALL PRESSURE RELIEF REFRIGERANT VENT PIPING — To facilitate refrigerant vent piping, units have flares for all of the relief fittings. The low side relief valves on all units are provided with a 3/4 in. NPT flare connections, and are located on the cooler shell. There are 2 relief valves for the cooler; one on each circuit.

The 30HXA high side relief valve is provided with a 5/8 in. SAE (Society of Automotive Engineers, U.S.A.) flare connection. The 30HXC high side relief valves are provided with a 3/4 in. NPT flare connection, and are located on the condenser shell.

There are 2 relief valves for the separator (30HXA) and 2 for the condenser (30HXC); one for each circuit. Most local codes require that these devices be piped to the outside. If vent piping is required by local codes, these connections have been provided to aid in the connection of vent piping in accordance with ASHRAE 15 (American Society of Heating, Refrigeration, and Air Conditioning Engineers), Safety Code for Mechanical Refrigeration. If vent piping is required, do not restrict the vent flow in any way.

NOTE: When accessory suction service valve kit is installed, there are 2 additional high-side pressure relief valves. Pipe these valves per local codes. These are located on the discharge line between the muffler and the discharge shut-off valve.

Step 4 — Make Electrical Connections — The electrical characteristics of the available power supply must agree with the unit nameplate rating. Supply voltage must be within the limits shown.

FIELD POWER CONNECTIONS (See Fig. 12) — All power wiring must comply with applicable local and national codes. Install field-supplied, branch circuit fused disconnect(s) of a type that can be locked off or open. Disconnect(s) must be located within sight and readily accessible from the unit in compliance with NEC Article 440-14. See Tables 4A and 4B for unit electrical data. See Tables 5A and 5B for compressor electrical data.

IMPORTANT: the 30HX units have a factory-installed option available for a non-fused disconnect for unit power supply. If the unit is equipped with this option, all field power wiring should be made to the non-fused disconnect since no terminal blocks are supplied.

All units have a single location for power entry to simplify the field power wiring. Maximum wire size that the unit terminal block or non-fused disconnect will accept is 500 kcmil.

All 380/415-3-50, 460-3-60, and 575-3-60 units require a single field-supplied power supply. All 230-3-50 and 208/230-3-60 units require 2 separate field-supplied power supplies.

All 380-3-60 units (except the 30HXC/A186 units) require a single field-supplied power supply. The 30HXC/A186 units require 2 field-supplied power supplies.

The 30HXA136-186 and 30HXC171,186, 346-3-50 units require 2 field-supplied power supplies. All other 346-3-50 units require a single field-supplied source.

FIELD CONTROL POWER CONNECTIONS (See Fig. 13) — Units with a power supply of 208/230-, 460-, and 575-3-60 require 115-1-60 control circuit power. Units with a 380-3-60 power supply require 230-1-60 control circuit power. All other units 230-1-50 control circuit power. Field control power connections are made at terminals 1 and 2 of TB4.

Copy continued on page 26.

Table 4A — Unit Electrical Data, 30HXC Units*

UNIT 30HXC	VOLTAGE		POWER CIRCUIT				CONTROL CIRCUIT				ICF		
	Nameplate (3 Ph)	Supplied		MCA	MOCP	Recommended Fuse Size	Voltage (Single Ph)	Min	Max	MCA	MOCP	WD	XL
		Min	Max										
076	208/230-60	187	253	123/123	200/200	175/150	115-60	104	127	15	15	307	†
	460-60	414	506	100	150	125	115-60	104	127			148	374
	575-60	518	633	80	110	100	115-60	104	127			118	299
	380-60	342	418	121	175	150	230-60	207	254			169	419
	230-50	207	253	115/115	200/200	150/150	230-50	198	254			266	†
	346-50	325	380	138	175	175	230-50	198	254			118	†
	380/415-50	342	440	126	175	150	230-50	198	254			165	400
086	208/230-60	187	253	148/123	250/200	200/150	115-60	104	127	15	15	307	†
	460-60	414	506	111	150	125	115-60	104	127			148	374
	575-60	518	633	89	125	100	115-60	104	127			118	299
	380-60	342	418	135	200	175	230-60	207	254			169	419
	230-50	207	253	140/115	250/200	75/150	230-50	198	254			305	†
	346-50	325	380	154	225	175	230-50	198	254			208	†
	380/415-50	342	440	140	200	175	230-50	198	254			190	479
096	208/230-60	187	253	181/122	300/200	225/150	115-60	104	127	15	15	354	†
	460-60	414	506	126	175	150	115-60	104	127			172	449
	575-60	518	633	101	150	125	115-60	104	127			137	359
	380-60	342	418	153	225	175	230-60	207	254			195	502
	230-50	207	253	169/115	300/200	225/150	230-50	198	254			347	†
	346-50	325	380	173	250	200	230-50	198	254			237	†
	380/415-50	342	440	158	225	200	230-50	198	254			216	562
106	208/230-60	187	253	219/123	350/200	300/150	115-60	104	127	15	15	405	†
	460-60	414	506	143	200	175	115-60	104	127			197	529
	575-60	518	633	115	175	150	115-60	104	127			158	423
	380-60	342	418	174	250	200	230-60	207	254			223	590
	230-50	207	253	202/115	350/200	250/150	230-50	198	254			397	†
	346-50	325	380	195	300	225	230-50	198	254			271	†
	380/415-50	342	440	178	250	225	230-50	198	254			247	661
116	208/230-60	187	253	219/148	350/250	300/200	115-60	104	127	15	15	426	†
	460-60	414	506	153	225	175	115-60	104	127			207	539
	575-60	518	633	122	175	150	115-60	104	127			166	431
	380-60	342	418	185	250	225	230-60	207	254			234	601
	230-50	207	253	202/140	350/250	250/175	230-50	198	254			417	†
	346-50	325	380	208	300	250	230-50	198	254			284	†
	380/415-50	342	440	190	250	225	230-50	198	254			259	673
126	208/230-60	187	253	219/181	350/300	300/225	115-60	104	127	15	15	452	†
	460-60	414	506	165	225	200	115-60	104	127			219	551
	575-60	518	633	131	175	150	115-60	104	127			175	440
	380-60	342	418	199	250	225	230-60	207	254			248	615
	230-50	207	253	202/169	350/300	250/225	230-50	198	254			440	†
	346-50	325	380	224	300	250	230-50	198	254			300	†
	380/415-50	342	440	204	300	250	230-50	198	254			273	687
136	208/230-60	187	253	263/181	450/300	350/225	115-60	104	127	15	15	512	†
	460-60	414	506	184	250	225	115-60	104	127			249	646
	575-60	518	633	147	200	175	115-60	104	127			199	536
	380-60	342	418	222	300	300	230-60	207	254			282	720
	230-50	207	253	245/169	400/300	300/225	230-50	198	254			496	†
	346-50	325	380	252	350	300	230-50	198	254			338	†
	380/415-50	342	440	230	300	300	230-50	198	254			308	797
146	208/230-60	187	253	263/219	450/350	350/300	115-60	104	127	15	15	542	†
	460-60	414	506	198	250	225	115-60	104	127			262	659
	575-60	518	633	158	225	200	115-60	104	127			210	547
	380-60	342	418	240	350	300	230-60	207	254			299	737
	230-50	207	253	245/202	400/350	300/250	230-50	198	254			523	†
	346-50	325	380	270	400	350	230-50	198	254			355	†
	380/415-50	342	440	246	350	300	230-50	198	254			324	813

See legend and notes on page 16.

Table 4A — Unit Electrical Data, 30HXC Units* (cont)

UNIT 30HXC	VOLTAGE			POWER CIRCUIT			CONTROL CIRCUIT				ICF		
	Nameplate (3 Ph)	Supplied		MCA	MOCP	Recommended Fuse Size	Voltage (Single Ph)	Min	Max	MCA	MOCP	WD	XL
		Min	Max										
161	208/230-60	187	253	285/197	500/350	350/250	115-60	104	127	15	15	591	†
	460-60	414	506	200	300	250	115-60	104	127			287	756
	575-60	518	633	160	225	200	115-60	104	127			230	605
	380-60	342	418	242	350	300	230-60	207	254			325	843
	230-50	207	253	266/182	450/300	350/225	230-50	198	254			578	†
	346-50	325	380	273	400	350	230-50	198	254			394	†
	380/415-50	342	440	249	350	300	230-50	198	254			358	944
171	208/230-60	187	253	238/285	400/500	300/400	115-60	104	127	15	15	624	†
	460-60	414	506	215	300	250	115-60	104	127			302	771
	575-60	518	633	172	250	200	115-60	104	127			242	617
	380-60	342	418	260	350	300	230-60	207	254			343	861
	230-50	207	253	219/266	350/450	300/350	230-50	198	254			607	†
	346-50	325	380	145/176	250/300	175/225	230-50	198	254			413	†
	380/415-50	342	440	267	350	300	230-50	198	254			376	962
186	208/230-60	187	253	285/285	500/500	400/400	115-60	104	127	15	15	661	†
	460-60	414	506	232	300	300	115-60	104	127			319	788
	575-60	518	633	185	250	225	115-60	104	127			255	630
	380-60	342	418	156/156	250/250	200/200	230-60	207	254			364	882
	230-50	207	253	266/266	450/450	350/350	230-50	198	254			645	†
	346-50	325	380	176/176	300/300	225/225	230-50	198	254			438	†
	380/415-50	342	440	289	400	350	230-50	198	254			399	985

LEGEND

- ICF** — Maximum Instantaneous Current Flow during start-up (the point in the starting sequence where the sum of the LRA for the start-up compressor, plus the total RLA for all running compressors, plus the total FLA for all running fan motors is at a maximum)
- MCA** — Minimum Circuit Ampacity (for wire sizing)
- MOCP** — Maximum Overcurrent Protection
- RLA** — Rated Load Amps
- WD** — Wye-Delta Start
- XL** — Across-the-Line Start

*Refer to Carrier's electronic catalog for the most current electrical data.

†Wye-Delta Start is standard. Not available in across-the-line start.

**The 30HX186 units have 2 terminal blocks/non-fused disconnects and 6 parallel conductors/non-fused disconnects.

††The 30HXC171 and 186 units have 2 terminal blocks/non-fused disconnects and 6 parallel conductors/non-fused disconnects.

NOTES:

1. Main power must be supplied from a field-supplied fused electrical service with a (factory- or field-installed) disconnect located in sight from the unit.
2. Control circuit power must be supplied from a separate source through a field-supplied disconnect. The control circuit accessory transformer may be applied to power from the main unit power supply.
3. Maximum incoming wire size for each terminal block is 500 kcmil.
4. Maximum allowable phase imbalance is: voltage, 2%; amps, 5%.
5. Units with one MCA value have one main terminal block. Units with 2 MCA values require multiple conductors.
6. Use copper conductors only.

7. The MOCP is calculated as follows:

MOCP = (2.25) (largest RLA) + the sum of the other RLAs. Size the fuse one size down from the result. The RLAs are listed on the unit nameplate.

The recommended fuse size in amps (RFA) is calculated as follows:

RFA = (1.50) (largest RLA) + the sum of the other RLAs. Size the fuse one size up from the result. The RLAs are listed on the unit nameplate.

8. Units have the following power wiring terminal blocks and parallel conductors:

VOLTAGE	TERMINAL BLOCKS OR NON-FUSED DISCONNECTS	PARALLEL CONDUCTORS OR NON-FUSED DISCONNECTS
208/230	2	6
460	1	3
575	1	3
380**	1	3
230	2	6
346††	1	3
380/415	1	3

Table 4B — Unit Electrical Data, 30HXA Units*

UNIT 30HXA	VOLTAGE			POWER CIRCUIT			CONTROL CIRCUIT				ICF		
	Nameplate (3 Ph)	Supplied		MCA	MOCP	Recommended Fuse Size	Voltage (Single Ph)	Min	Max	MCA	MOCP	WD	XL
		Min	Max										
076	208/230-60	187	253	180/180	300/300	225/225	115-60	104	127	15	15	451	†
	460-60	414	506	146	200	175	115-60	104	127			218	550
	575-60	518	633	117	150	150	115-60	104	127			175	440
	380-60	342	418	177	250	200	230-60	207	254			248	615
	230-50	207	253	169/169	300/300	225/225	230-50	198	254			440	†
	346-50	325	380	201	250	225	230-50	198	254			299	†
	380/415-50	342	440	183	250	225	230-50	198	254			273	687
086	208/230-60	187	253	215/180	350/300	300/225	115-60	104	127	15	15	511	†
	460-60	414	506	162	225	200	115-60	104	127			248	645
	575-60	518	633	130	175	150	115-60	104	127			199	536
	380-60	342	418	196	250	225	230-60	207	254			282	720
	230-50	207	253	205/169	350/300	250/225	230-50	198	254			496	†
	346-50	325	380	225	300	300	230-50	198	254			337	†
	380/415-50	342	440	206	300	250	230-50	198	254			308	797
096	208/230-60	187	253	262/180	450/300	350/225	115-60	104	127	15	15	577	†
	460-60	414	506	183	250	225	115-60	104	127			281	750
	575-60	518	633	147	200	175	115-60	104	127			225	600
	380-60	342	418	222	300	300	230-60	207	254			318	836
	230-50	207	253	248/169	400/300	300/225	230-50	198	254			567	†
	346-50	325	380	254	350	300	230-50	198	254			386	†
	380/415-50	342	440	231	350	300	230-50	198	254			352	938
106	208/230-60	187	253	319/180	500/300	400/225	115-60	104	127	15	15	662	†
	460-60	414	506	209	300	250	115-60	104	127			324	885
	575-60	518	633	167	250	200	115-60	104	127			259	708
	380-60	342	418	253	350	300	230-60	207	254			365	985
	230-50	207	253	300/169	500/300	400/225	230-50	198	254			620	†
	346-50	325	380	289	400	350	230-50	198	254			423	†
	380/415-50	342	440	263	400	300	230-50	198	254			385	1042
116	208/230-60	187	253	319/215	500/350	400/300	115-60	104	127	15	15	690	†
	460-60	414	506	222	300	300	115-60	104	127			337	898
	575-60	518	633	177	250	200	115-60	104	127			269	718
	380-60	342	418	269	400	350	230-60	207	254			380	1000
	230-50	207	253	300/205	500/350	400/250	230-50	198	254			649	†
	346-50	325	380	308	450	350	230-50	198	254			443	†
	380/415-50	342	440	281	400	350	230-50	198	254			402	1059
126	208/230-60	187	253	319/262	500/450	400/350	115-60	104	127	15	15	728	†
	460-60	414	506	239	350	300	115-60	104	127			354	915
	575-60	518	633	191	250	225	115-60	104	127			283	732
	380-60	342	418	289	400	350	230-60	207	254			401	1021
	230-50	207	253	300/248	500/400	400/300	230-50	198	254			683	†
	346-50	325	380	331	400	400	230-50	198	254			465	†
	380/415-50	342	440	302	400	350	230-50	198	254			423	1080
136	208/230-60	187	253	389/262	700/450	500/350	115-60	104	127	15	15	791	†
	460-60	414	506	271	400	350	115-60	104	127			386	1015
	575-60	518	633	216	300	250	115-60	104	127			309	812
	380-60	342	418	328	450	400	230-60	207	254			436	1132
	230-50	207	253	369/248	600/400	450/300	230-50	198	254			817	†
	346-50	325	380	245/164	400/250	300/200	230-50	198	254			557	†
	380/415-50	342	440	343	500	400	230-50	198	254			507	1346
146	208/230-60	187	253	389/319	700/500	500/400	115-60	104	127	15	15	837	†
	460-60	414	506	291	400	350	115-60	104	127			406	1035
	575-60	518	633	233	300	300	115-60	104	127			325	828
	380-60	342	418	353	500	400	230-60	207	254			461	1157
	230-50	207	253	369/300	600/500	450/400	230-50	198	254			859	†
	346-50	325	380	245/199	400/350	300/250	230-50	198	254			585	†
	380/415-50	342	440	369	500	450	230-50	198	254			532	1371

See legend and notes on page 18.

Table 4B — Unit Electrical Data, 30HXA Units* (cont)

UNIT 30HXA	VOLTAGE			POWER CIRCUIT			CONTROL CIRCUIT				ICF		
	Nameplate (3 Ph)	Supplied		MCA	MOCP	Recommended Fuse Size	Voltage (Single Ph)	Min	Max	MCA	MOCP	WD	XL
		Min	Max										
161	208/230-60	187	253	437/295	700/500	600/400	115-60	104	127	15	15	979	†
	460-60	414	506	304	450	350	115-60	104	127			478	1282
	575-60	518	633	243	350	300	115-60	104	127			382	1025
	380-60	342	418	368	500	450	230-60	207	254			539	1428
	230-50	207	253	415/275	700/450	500/350	230-50	198	254			858	†
	346-50	325	380	276/183	450/300	350/225	230-50	198	254			535	†
	380/415-50	342	440	385	500	450	230-50	198	254			533	1398
171	208/230-60	187	253	359/437	600/700	450/600	115-60	104	127	15	15	1030	†
	460-60	414	506	327	450	400	115-60	104	127			501	1305
	575-60	518	633	261	350	300	115-60	104	127			401	1044
	380-60	342	418	396	500	450	230-60	207	254			567	1456
	230-50	207	253	334/415	600/700	450/500	230-50	198	254			905	†
	346-50	325	380	222/276	350/450	300/350	230-50	198	254			616	†
	380/415-50	342	440	413	600	500	230-50	198	254			562	1427
186	208/230-60	187	253	437/437	700/700	600/600	115-60	104	127	15	15	1093	†
	460-60	414	506	355	500	400	115-60	104	127			529	1333
	575-60	518	633	284	400	350	115-60	104	127			539	1066
	380-60	342	418	239/239	400/400	300/300	230-60	207	254			601	1490
	230-50	207	253	415/415	700/700	500/500	230-50	198	254			970	†
	346-50	325	380	276/276	450/450	350/350	230-50	198	254			660	†
	380/415-50	342	440	453	600	600	230-50	198	254			601	1466

LEGEND

- ICF** — Maximum Instantaneous Current Flow during start-up (the point in the starting sequence where the sum of the LRA for the start-up compressor, plus the total RLA for all running compressors, plus the total FLA for all running fan motors is at a maximum)
- MCA** — Minimum Circuit Ampacity (for wire sizing)
- MOCP** — Maximum Overcurrent Protection
- RLA** — Rated Load Amps
- WD** — Wye-Delta Start
- XL** — Across-the-Line Start

*Refer to Carrier's electronic catalog for the most current electrical data.

†Wye-Delta Start is standard. Not available in across-the-line start.

**The 30HX186 units have 2 terminal blocks/non-fused disconnects and 6 parallel conductors/non-fused disconnects.

††The 30HXA136-186 units have 2 terminal blocks/non-fused disconnects and 6 parallel conductors/non-fused disconnects.

NOTES:

1. Main power must be supplied from a field-supplied fused electrical service with a (factory- or field-installed) disconnect located in sight from the unit.
2. Control circuit power must be supplied from a separate source through a field-supplied disconnect. The control circuit accessory transformer may be applied to power from the main unit power supply.
3. Maximum incoming wire size for each terminal block is 500 kcmil.
4. Maximum allowable phase imbalance is: voltage, 2%; amps, 5%.
5. Units with one MCA value have one main terminal block. Units with 2 MCA values require multiple conductors.
6. Use copper conductors only.

7. The MOCP is calculated as follows:

MOCP = (2.25) (largest RLA) + the sum of the other RLAs. Size the fuse one size down from the result. The RLAs are listed on the unit nameplate.

The recommended fuse size in amps (RFA) is calculated as follows:

RFA = (1.50) (largest RLA) + the sum of the other RLAs. Size the fuse one size up from the result. The RLAs are listed on the unit nameplate.

8. Units have the following power wiring terminal blocks and parallel conductors:

VOLTAGE	TERMINAL BLOCKS OR NON-FUSED DISCONNECTS	PARALLEL CONDUCTORS OR NON-FUSED DISCONNECTS
208/230	2	6
460	1	3
575	1	3
380**	1	3
230	2	6
346††	1	3
380/415	1	3

Table 5A — Compressor Electrical Data, 30HXC Units

UNIT SIZE 30HXC	NAMEPLATE V-Hz (3 Phase)	COMPRESSOR NUMBERS			
		A1		B1	
		RLA	LRA	RLA	LRA
076	208/230-60	*	*	*	*
	460-60	44.3	330	44.3	330
	575-60	35.4	264	35.4	264
	380-60	53.7	365	53.7	365
	230-50	*	*	*	*
	346-50	*	*	*	*
	380/415-50	55.8	344	55.8	344
076-WD	208/230-60	98.1	209	98.1	209
	460-60	44.3	104	44.3	104
	575-60	35.4	83	35.4	83
	380-60	53.7	115	53.7	115
	230-50	92.1	174	92.1	174
	346-50	61.1	120	61.1	120
	380/415-50	55.8	109	55.8	109
086	208/230-60	*	*	*	*
	460-60	53.6	330	44.3	330
	575-60	42.8	264	35.4	264
	380-60	64.9	365	53.7	365
	230-50	*	*	*	*
	346-50	*	*	*	*
	380/415-50	67.7	423	55.8	344
086-WD	208/230-60	118.6	209	98.1	209
	460-60	53.6	104	44.3	104
	575-60	42.8	83	35.4	83
	380-60	64.9	115	53.7	115
	230-50	111.8	213	92.1	174
	346-50	74.2	147	61.1	120
	380/415-50	67.7	134	55.8	109
096	208/230-60	*	*	*	*
	460-60	65.5	405	44.3	330
	575-60	52.3	324	35.4	264
	380-60	79.2	448	53.7	365
	230-50	*	*	*	*
	346-50	*	*	*	*
	380/415-50	81.7	506	55.8	344
096-WD	208/230-60	144.9	256	98.1	209
	460-60	65.5	128	44.3	104
	575-60	52.3	102	35.4	83
	380-60	79.2	141	53.7	115
	230-50	134.9	255	92.1	174
	346-50	89.5	176	61.1	120
	380/415-50	81.7	160	55.8	109
106	208/230-60	*	*	*	*
	460-60	79.2	485	44.3	330
	575-60	63.3	388	35.4	264
	380-60	95.9	536	53.7	365
	230-50	*	*	*	*
	346-50	*	*	*	*
	380/415-50	97.8	605	55.8	344
106-WD	208/230-60	175.4	307	98.1	209
	460-60	79.2	153	44.3	104
	575-60	63.3	123	35.4	83
	380-60	95.9	169	53.7	115
	230-50	161.7	305	92.1	174
	346-50	107.3	210	61.1	120
	380/415-50	97.8	191	55.8	109
116	208/230-60	*	*	*	*
	460-60	79.2	485	53.6	330
	575-60	63.3	388	42.8	264
	380-60	95.9	536	64.9	365
	230-50	*	*	*	*
	346-50	*	*	*	*
	380/415-50	87.8	605	67.7	423
116-WD	208/230-60	175.4	307	118.6	209
	460-60	79.2	153	53.6	104
	575-60	63.3	123	42.8	83
	380-60	95.5	169	64.9	115
	230-50	161.7	305	111.8	213
	346-50	107.3	210	74.2	147
	380/415-50	97.8	191	67.7	134

LEGEND

- LRA** — Locked Rotor Amps
- RLA** — Rated Load Amps
- WD** — Wye-Delta Start

*Units are shipped with wye-delta start as standard. Across-the-line start is not available.

Table 5A — Compressor Electrical Data, 30HXC Units (cont)

UNIT SIZE 30HXC	NAMEPLATE V-Hz (3 Phase)	COMPRESSOR NUMBERS			
		A1		B1	
		RLA	LRA	RLA	LRA
126	208/230-60	*	*	*	*
	460-60	79.2	485	65.5	405
	575-60	63.3	388	52.3	324
	380-60	95.9	536	79.2	448
	230-50	*	*	*	*
	346-50	*	*	*	*
	380/415-50	97.8	605	81.7	506
126-WD	208/230-60	175.4	307	144.9	256
	460-60	79.2	153	65.5	128
	575-60	63.3	123	52.3	102
	380-60	95.9	169	79.2	141
	230-50	161.7	305	134.9	255
	346-50	107.3	210	89.5	176
	380/415-50	97.8	191	81.7	160
136	208/230-60	*	*	*	*
	460-60	94.9	580	65.5	405
	575-60	75.8	484	52.3	324
	380-60	114.9	641	79.2	448
	230-50	*	*	*	*
	346-50	*	*	*	*
	380/415-50	118.8	715	81.7	506
136-WD	208/230-60	210.0	367	144.9	256
	460-60	94.6	183	65.5	128
	575-60	75.8	147	52.3	102
	380-60	114.9	203	79.2	141
	230-50	196.3	361	134.9	255
	346-50	130.3	248	89.5	176
	380/415-50	118.8	226	81.7	160
146	208/230-60	*	*	*	*
	460-60	94.9	580	79.2	485
	575-60	75.8	484	63.3	388
	380-60	114.9	641	95.9	536
	230-50	*	*	*	*
	346-50	*	*	*	*
	380/415-50	118.8	715	97.8	605
146-WD	208/230-60	210.0	367	175.4	307
	460-60	94.9	183	79.2	153
	575-60	75.8	147	63.3	123
	380-60	114.9	203	95.9	169
	230-50	196.3	361	161.7	305
	346-50	130.3	248	107.3	210
	380/415-50	118.8	226	97.8	191
161	208/230-60	*	*	*	*
	460-60	103.1	685	71.2	525
	575-60	82.4	548	56.9	420
	380-60	124.8	757	86.2	580
	230-50	*	*	*	*
	346-50	*	*	*	*
	380/415-50	128.6	856	88.2	600
161-WD	208/230-60	228.8	433	157.6	350
	460-60	103.1	216	71.2	175
	575-60	82.4	173	56.9	140
	380-60	124.8	239	86.2	193
	230-50	212.5	432	145.7	348
	346-50	141.0	297	96.7	232
	380/415-50	128.6	270	88.2	200
171	208/230-60	*	*	*	*
	460-60	86.1	580	103.1	685
	575-60	68.8	484	82.4	548
	380-60	104.2	641	124.8	757
	230-50	*	*	*	*
	346-50	*	*	*	*
	380/415-50	105.8	715	128.6	856
171-WD	208/230-60	190.6	367	228.8	433
	460-60	86.1	183	103.1	216
	575-60	68.8	147	82.4	173
	380-60	104.2	203	124.8	239
	230-50	174.8	361	212.5	432
	346-50	116.0	248	141.0	297
	380/415-50	105.8	233	128.6	270

LEGEND

- LRA** — Locked Rotor Amps
- RLA** — Rated Load Amps
- WD** — Wye-Delta Start

*Units are shipped with wye-delta start as standard. Across-the-line start is not available.

Table 5A — Compressor Electrical Data, 30HXC Units (cont)

UNIT SIZE 30HXC	NAMEPLATE V-Hz (3 Phase)	COMPRESSOR NUMBERS			
		A1		B1	
		RLA	LRA	RLA	LRA
186	208/230-60	*	*	*	*
	460-60	103.1	685	103.1	685
	575-60	82.4	548	82.4	548
	380-60	124.8	757	124.8	757
	230-50	*	*	*	*
	346-50	*	*	*	*
	380/415-50	128.6	856	128.6	856
186-WD	208/230-60	228.8	433	228.8	433
	460-60	103.1	216	103.1	216
	575-60	82.4	173	82.4	173
	380-60	124.8	239	124.8	239
	230-50	212.5	432	212.5	432
	346-50	141.0	297	141.0	297
	380/415-50	128.6	270	128.6	270

LEGEND

- LRA** — Locked Rotor Amps
- RLA** — Rated Load Amps
- WD** — Wye-Delta Start

*Units are shipped with wye-delta start as standard. Across-the-line start is not available.

Table 5B — Compressor Electrical Data, 30HXA Units

UNIT SIZE 30HXA	NAMEPLATE V-Hz (3 Phase)	COMPRESSOR NUMBERS			
		A1		B1	
		RLA	LRA	RLA	LRA
076	208/230-60	*	*	*	*
	460-60	64.9	485	64.9	485
	575-60	51.9	388	51.9	388
	380-60	78.7	536	78.7	536
	230-50	*	*	*	*
	346-50	*	*	*	*
	380/415-50	81.5	605	81.5	605
076-WD	208/230-60	143.8	307	143.8	307
	460-60	64.9	153	64.9	153
	575-60	51.9	123	51.9	123
	380-60	78.7	169	78.7	169
	230-50	134.8	305	134.8	305
	346-50	89.4	210	89.4	210
	380/415-50	81.5	191	81.5	191
086	208/230-60	*	*	*	*
	460-60	77.6	580	64.9	485
	575-60	62.1	484	51.9	388
	380-60	94.0	641	78.7	536
	230-50	*	*	*	*
	346-50	*	*	*	*
	380/415-50	99.2	715	81.5	605
086-WD	208/230-60	171.9	367	143.8	307
	460-60	77.6	183	64.9	153
	575-60	62.1	147	51.9	123
	380-60	94.0	203	78.7	169
	230-50	163.9	361	134.8	305
	346-50	108.8	248	89.4	210
	380/415-50	99.2	226	81.5	191
096	208/230-60	*	*	*	*
	460-60	94.8	685	64.9	485
	575-60	75.7	548	51.9	388
	380-60	114.7	757	78.7	536
	230-50	*	*	*	*
	346-50	*	*	*	*
	380/415-50	119.9	856	81.5	685
096-WD	208/230-60	209.8	433	143.8	307
	460-60	94.8	216	64.9	153
	575-60	75.5	173	51.9	123
	380-60	114.7	239	78.7	169
	230-50	198.2	432	134.8	305
	346-50	131.4	297	89.4	210
	380/415-50	119.9	270	81.5	191
106	208/230-60	*	*	*	*
	460-60	115.4	820	64.9	485
	575-60	92.2	656	51.9	388
	380-60	139.7	906	78.7	536
	230-50	*	*	*	*
	346-50	*	*	*	*
	380/415-50	145.4	960	81.5	605
106-WD	208/230-60	255.5	518	143.8	307
	460-60	115.4	259	64.9	153
	575-60	92.2	207	51.9	123
	380-60	139.7	286	78.7	169
	230-50	240.2	485	134.8	305
	346-50	159.4	334	89.4	210
	380/415-50	145.4	303	81.5	191
116	208/230-60	*	*	*	*
	460-60	115.4	820	77.6	580
	575-60	92.2	656	62.1	484
	380-60	139.7	906	94.0	641
	230-50	*	*	*	*
	346-50	*	*	*	*
	380/415-50	145.4	960	99.2	715
116-WD	208/230-60	255.5	578	171.9	367
	460-60	115.4	259	77.6	183
	575-60	92.2	207	62.1	147
	380-60	139.7	286	94.0	203
	230-50	240.2	485	163.9	361
	346-50	159.4	334	108.8	248
	380/415-50	145.4	303	99.2	226

LEGEND

- LRA** — Locked Rotor Amps
- RLA** — Rated Load Amps
- WD** — Wye-Delta Start

*Units are shipped with wye-delta start as standard. Across-the-line start is not available.

Table 5B — Compressor Electrical Data, 30HXA Units (cont)

UNIT SIZE 30HXA	NAMEPLATE V-Hz (3 Phase)	COMPRESSOR NUMBERS			
		A1		B1	
		RLA	LRA	RLA	LRA
126	208/230-60	*	*	*	*
	460-60	115.4	820	94.8	685
	575-60	92.2	656	75.7	548
	380-60	139.7	906	114.7	757
	230-50	*	*	*	*
	346-50	*	*	*	*
	380/415-50	145.4	960	119.9	856
126-WD	208/230-60	255.5	518	209.8	447
	460-60	115.4	259	94.8	216
	575-60	92.2	207	75.7	173
	380-60	139.7	286	114.7	239
	230-50	240.2	485	198.2	432
	346-50	159.4	334	131.4	297
	380/415-50	145.4	303	119.9	270
136	208/230-60	*	*	*	*
	460-60	140.7	920	94.8	685
	575-60	112.4	736	75.7	548
	380-60	170.2	1017	114.7	757
	230-50	*	*	*	*
	346-50	*	*	*	*
	380/415-50	178.8	1226	119.9	856
136-WD	208/230-60	311.4	581	209.8	433
	460-60	140.7	291	94.8	216
	575-60	112.4	233	75.7	173
	380-60	170.2	321	114.7	239
	230-50	295.3	619	198.2	432
	346-50	195.9	426	131.4	297
	380/415-50	178.8	387	119.9	276
146	208/230-60	*	*	*	*
	460-60	140.7	920	115.4	820
	575-60	112.4	736	92.2	656
	380-60	170.2	1017	139.7	906
	230-50	*	*	*	*
	346-50	*	*	*	*
	380/415-50	178.8	1226	145.4	960
146-WD	208/230-60	311.4	581	255.5	518
	460-60	140.7	291	115.4	259
	575-60	112.4	233	92.2	207
	380-60	170.2	321	139.7	286
	230-50	295.3	619	240.2	485
	346-50	195.9	426	159.4	334
	380/415-50	178.8	387	145.4	303
161	208/230-60	*	*	*	*
	460-60	157.9	1175	106.6	790
	575-60	126.2	940	85.1	630
	380-60	191.2	1299	129.0	870
	230-50	*	*	*	*
	346-50	*	*	*	*
	380/415-50	201.2	1265	133.4	1045
161-WD	208/230-60	349.6	743	235.9	527
	460-60	157.9	371	106.6	263
	575-60	126.2	297	85.1	211
	380-60	191.2	410	129.0	290
	230-50	332.3	638	220.3	607
	346-50	220.5	439	146.2	402
	380/415-50	201.2	400	133.4	348
171	208/230-60	*	*	*	*
	460-60	129.6	920	157.9	1175
	575-60	103.6	736	126.2	940
	380-60	156.9	1017	191.2	1299
	230-50	*	*	*	*
	346-50	*	*	*	*
	380/415-50	161.7	1226	201.2	1265
171-WD	208/230-60	286.9	581	349.6	743
	460-60	129.6	291	157.9	371
	575-60	103.6	233	126.2	297
	380-60	156.9	321	191.2	410
	230-50	267.2	619	332.3	638
	346-50	177.3	426	220.5	439
	380/415-50	161.7	387	201.2	400

LEGEND

LRA — Locked Rotor Amps
RLA — Rated Load Amps
WD — Wye-Delta Start

*Units are shipped with wye-delta start as standard. Across-the-line start is not available.

Table 5B — Compressor Electrical Data, 30HXA Units (cont)

UNIT SIZE 30HXA	NAMEPLATE V-Hz (3 Phase)	COMPRESSOR NUMBERS			
		A1		B1	
		RLA	LRA	RLA	LRA
186	208/230-60	*	*	*	*
	460-60	157.9	1175	157.9	1175
	575-60	126.2	940	126.2	940
	380-60	191.2	1299	191.2	1299
	230-50	*	*	*	*
	346-50	*	*	*	*
	380/415-50	201.2	1265	201.2	1265
186-WD	208/230-60	349.6	743	349.6	743
	460-60	157.9	371	157.9	371
	575-60	126.2	297	126.2	297
	380-60	191.2	410	191.2	410
	230-50	332.3	638	332.3	638
	346-50	220.5	439	220.5	439
	380/415-50	201.2	400	201.2	400

LEGEND

- LRA — Locked Rotor Amps
- RLA — Rated Load Amps
- WD — Wye-Delta Start

*Units are shipped with wye-delta start as standard. Across-the-line start is not available.

STANDARD POWER

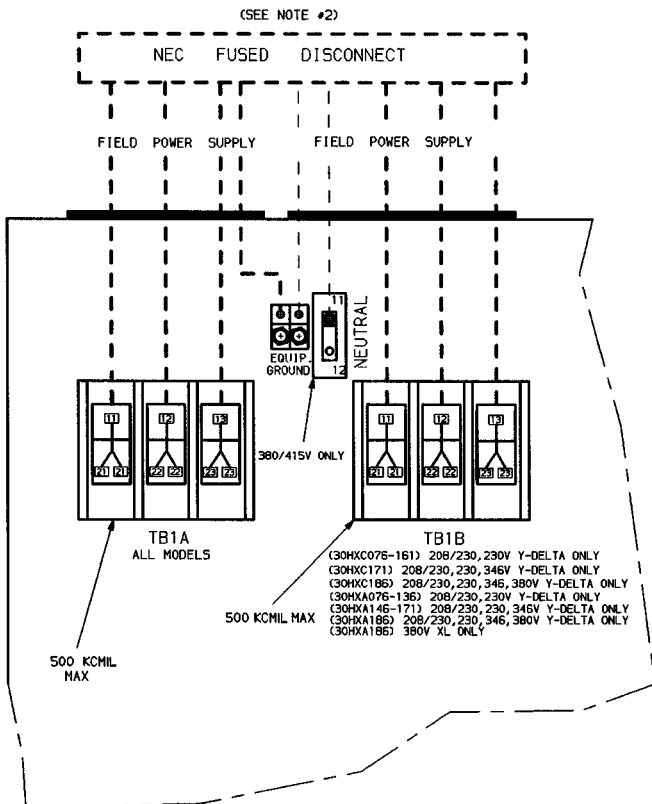

NON-FUSED DISCONNECT OPTION

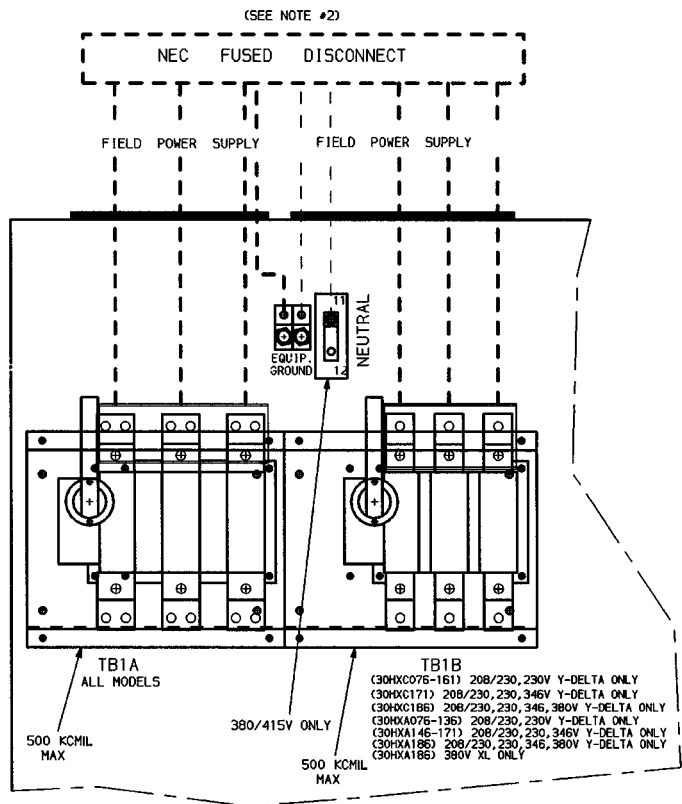

LEGEND

- EQUIP — Equipment
- NEC — National Electrical Code (U.S.A.)
- TB — Terminal Block
- Y-Delta — Wye-Delta Start
- XL — Across-the-Line Start
- --- Field Power Wiring
- --- Field Control Wiring
- — — Factory-Installed Wiring

NOTES:

1. Factory wiring is in accordance with NEC. Field modifications or additions must be in compliance with all applicable codes.
2. Wiring for main field supply must be rated 75° C minimum. Use copper for all units. Maximum incoming wire size for each terminal block is 500 kcmil.

Fig. 12 — Field Power Wiring

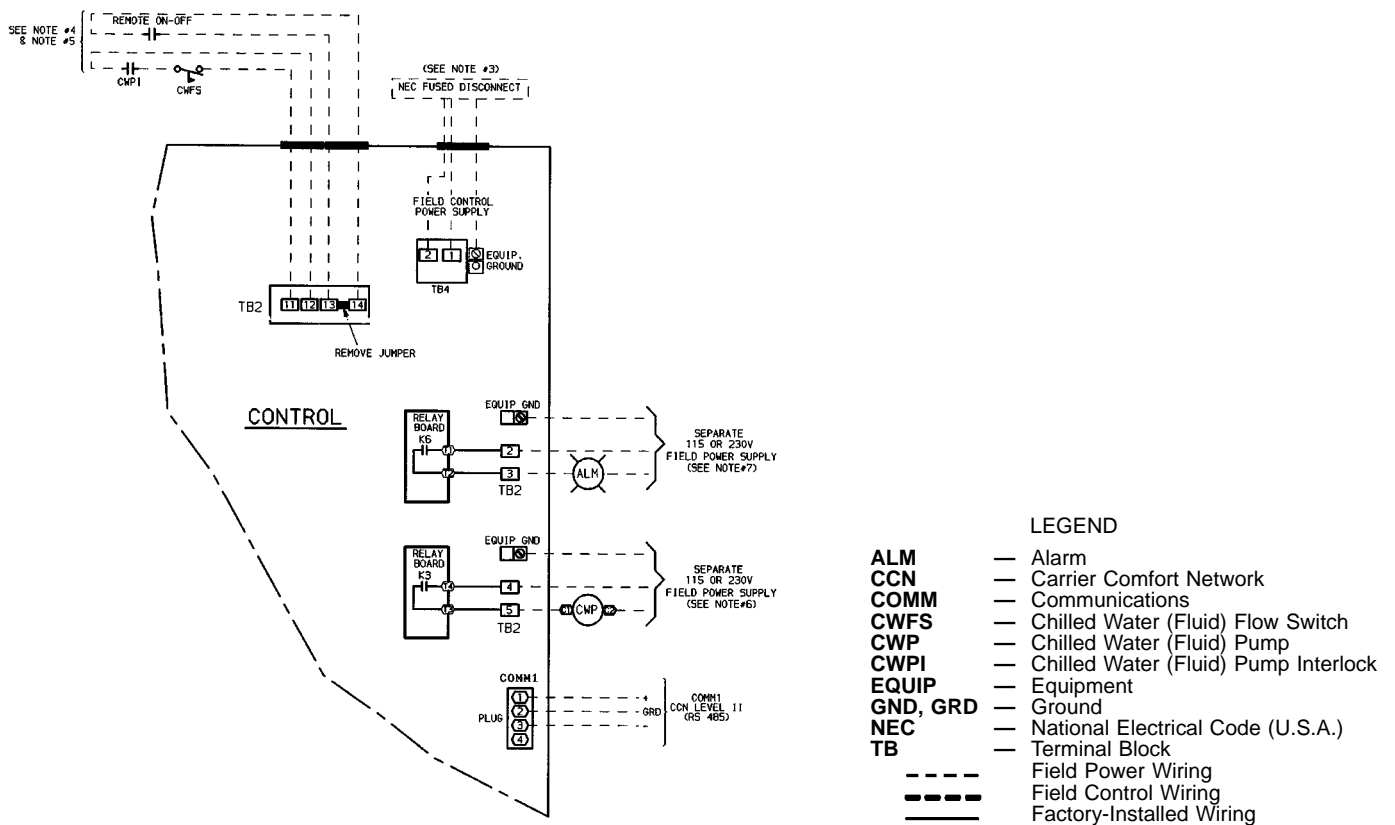

NOTES:

1. Factory wiring is in accordance with NEC. Field modifications or additions must be in compliance with all applicable codes.
2. Wiring for main field supply must be rated 75° C minimum. Use copper for all units. Maximum incoming wire size for each terminal block is 500 kcmil.
3. Power for control circuit should be supplied from a separate source through a field-supplied, fused disconnect with 15 amp maximum protection for all control circuits. Connect control circuit power to terminals 1 and 2 of TB4. Connect neutral side of supply to terminal 2 of TB4. Control circuit conductors for all units must be copper only.
4. Terminals 13 and 14 of TB2 are for field external connection for remote on-off. The contacts must be rated for dry circuit application capable of handling a 24 vac to 50 mA load. Remove jumper between 13 and 14 of TB2 if remote on-off is installed.
5. Terminals 11 and 12 of TB2 are for chilled water flow switch (CWFS) and chilled water pump interlock (CWPI) functions. The contacts must be rated for dry circuit application capable of handling a 24 vac to 50 mA load.
6. Terminals 4 and 5 of TB2 are for control of chilled water pump starter. The maximum load allowed for the chilled water pump relay is 125 va sealed, 1250 va inrush.
7. Terminals 2 and 3 of TB2 are for alarm. The maximum load allowed for the alarm is 125 va sealed, 1250 va inrush.

Fig. 13 — Field Control Wiring

Terminals TB2-11 and TB2-12 are provided for field installation of a chilled water (fluid) pump interlock (CWPI) and a chilled water (fluid) flow switch (CWFS). These devices are to be installed in series. Contacts must be rated for day circuit applications capable of handling a 24-vac to 50 mA load.

Accessory remote on-off switch can be wired into TB2-13 and TB2-14. To use this feature, remove the factory-installed jumper and install the device in series. See Fig. 13 for remote on-off, CWPI, and CWFS wiring. Contacts must be rated for dry load application capable of handling a 24-vac to 50 mA load.

⚠ CAUTION

Do not use interlocks or other safety device contacts connected between TB2 terminals 13 and 14 as remote on-off. Connection of safeties or other interlocks between these 2 terminals will result in an electrical bypass if the REMOTE-OFF-LOCAL switch is in the LOCAL position. If remote on-off unit control is required, a field-supplied relay must be installed in the unit control box and wired as shown in Fig. 13. Failure to wire the remote on-off as recommended will result in tube freeze damage.

Terminals 2 and 3 of TB2 have been provided for a field-supplied remote alarm (ALM). If an audible alarm is installed, an alarm shutoff is also recommended. Contacts are rated for 125 va at either 115 or 230 v control power. See Fig. 13.

Terminals 4 and 5 of TB2 have been provided for a field-supplied chilled water (fluid) pump relay (CWP). A field-supplied power supply of appropriate voltage must be provided. Contacts are rated for 125 va at either 115 or 230 v control power. See Fig. 13.

Terminals 1 and 6 of TB2 have been provided for a field-supplied control relay for the remote condenser (30HXA) or a condenser pump relay (30HXC). A field-supplied power supply of appropriate voltage must be provided.

Step 5 — Install Accessories

ELECTRICAL — Several optional control accessories are available to provide the following features:

- control transformer
- cooler pump/flow switch interlock
- cooler pump control
- expanded display panel
- remote alarm
- remote on-off
- pulldown control
- occupancy scheduling
- demand limit control
- temperature reset (from occupied space or outdoor-air temperature)
- dual set point control
- condenser water sensors
- level II communications (CCN [Carrier Comfort Network])

Refer to Start-Up and Operation literature and separate accessory installation instructions for additional information.

30HXA LOW-AMBIENT OPERATION — If outdoor ambient operating temperatures below 60 F (15 C) are expected, refer to separate installation instructions for low-ambient operation using accessory Motormaster® III control.

MINIMUM LOAD ACCESSORY — If minimum load accessory is required, use the appropriate package. Refer to unit Price Pages or contact your local Carrier representative for more details. For installation details, refer to separate installation instructions supplied with the accessory package.

MISCELLANEOUS ACCESSORIES — For applications requiring special accessories, the following packages are available: control power transformer, minimum load control, sound reduction enclosure, external vibration isolation, expanded display, Victaulic-type connections, temperature reset sensor, and chilled fluid flow switch. Refer to individual accessory installation instructions for installation details.

Step 6 — Leak Test Unit

30HXC UNIT — These units are shipped from the factory with a full charge of R-134a (See Tables 1A and 1B). Perform a leak test to ensure that leaks have not developed during unit shipment. Dehydration of the system is not required unless the entire refrigerant charge has been lost. There are a number of Swage-Lok fittings used on the refrigerant piping. If a leak is detected at any of these fittings, tighten outside nut 1/8 turn.

⚠ CAUTION

DO NOT OVERTIGHTEN THESE FITTINGS. Overtightening will result in the tube being crushed and will cause a refrigerant system leak.

30HXA UNITS — These units are shipped with a holding charge of R-134a. Leak test and dehydrate the complete system (including both field and factory installed piping).

Step 7 — Refrigerant Charge

IMPORTANT: These units are designed for use with R-134a only. **DO NOT USE ANY OTHER** refrigerant in these units without first consulting your Carrier representative.

The liquid charging method is recommended for complete charging or when additional charge is required.

⚠ CAUTION

When charging, circulate water through the condenser and cooler at all times to prevent freezing. Freezing damage is considered abuse and may void the Carrier warranty.

⚠ CAUTION

DO NOT OVERCHARGE system. Overcharging results in higher discharge pressure with higher cooling fluid consumption, possible compressor damage, and higher power consumption.

30HXC UNITS — The 30HXC units are shipped from the factory with a full charge of R-134a. Unit should not need to be charged at installation unless a leak was detected in Step 6 — Leak Test Unit section on page 26. If dehydration and recharging is necessary, use industry standard practices or refer to Carrier Standard Services Techniques Manual as required.

30HXA UNITS — The 30HXA units are shipped with a holding charge of R-134a. The complete charge for the 30HXA, the remote condenser(s), and interconnecting piping must be field supplied.

To charge the 30HXA systems:

1. Add liquid charge into the cooler using the 1/4-in. Schrader-type fitting located on the tube going into the bottom of the cooler. This fitting is located between the electronic expansion valve (EXV) (076-146 units) or the economizer (161-186 units) and the cooler. Add approximately 2 lb/nominal ton (0.9 kg/nominal kW). This amount of charge should be sufficient to allow the unit to start. The approximate system charges are shown in Table 6.
2. Raise the compressor discharge to approximately 125 F (51.7 C) saturated discharge temperature (185 psig [1276 kPa]) by throttling the condenser air (or water) intake. Add charge until there is approximately 18 to 20 F (10.0 to 11.1 C) of system subcooling (saturated discharge temperature – actual temperature entering the EXV).

NOTE: On the units equipped with economizers (30HXA161-186), the EXV is located inside the economizer so the temperature must be measured entering the economizer (tube entering bottom of economizer).

3. Check for a clear sight glass. If the unit is not fully loaded, the sight glass might be flashing. This is normal for a partially-loaded unit.

Table 6 — 30HXA System Charge for Start-Up

UNIT 30HXA	CIRCUIT A CHARGE		CIRCUIT B CHARGE	
	Lb	Kg	Lb	Kg
076	75	34.0	75	34.0
086	94	42.6	80	36.3
096	114	51.7	80	36.3
106	134	60.8	80	36.3
116	137	62.1	95	43.1
126	137	62.1	116	52.6
136	147	66.7	125	56.7
146	161	73.0	132	59.9
161	190	86.2	132	59.9
171	154	69.9	186	84.4
186	186	84.4	186	84.4

PACKAGED SERVICE TRAINING

Our packaged service training programs provide an excellent way to increase your knowledge of the equipment discussed in this manual. Product programs cover:

- Unit Familiarization
- Maintenance
- Installation Overview
- Operating Sequence

A large selection of product, theory, and skills programs is available. All programs include a video cassette and/or slides and a companion booklet. Use these for self teaching or to conduct full training sessions.

For a free Service Training Material Catalog (STM), call 1-800-962-9212. Ordering instructions are included.

Free Manuals Download Website

<http://myh66.com>

<http://usermanuals.us>

<http://www.somanuals.com>

<http://www.4manuals.cc>

<http://www.manual-lib.com>

<http://www.404manual.com>

<http://www.luxmanual.com>

<http://aubethermostatmanual.com>

Golf course search by state

<http://golfingnear.com>

Email search by domain

<http://emailbydomain.com>

Auto manuals search

<http://auto.somanuals.com>

TV manuals search

<http://tv.somanuals.com>