

## Air-Cooled Condensing Units

### INDEX

	Page
SAFETY CONSIDERATIONS .....	1
INSTALLATION	
<b>Step 1 — Check Equipment and Jobsite</b> ....	2,3
• UNPACKAGE UNIT	
• INSPECT EQUIPMENT	
• COMPLETE OR CONSIDER SYSTEM REQUIREMENTS	
<b>Step 2 — Make Tubing Connections</b> .....	3-5
• REPLACE THE ACCURATER™ REFRIGERANT CONTROL PISTON IN THE INDOOR COIL	
• CONNECT REFRIGERANT LINES	
<b>Step 3 — Make Electrical Connections</b> ....	5,6
• INSTALL A BRANCH CIRCUIT DISCONNECT PER N.E.C.	
• ROUTE LINE POWER LEADS INTO UNIT	
• CONNECT GROUND LEAD AND POWER WIRING	
• CONNECT CONTROL POWER WIRING (24 v)	
START-UP .....	6
SERVICE .....	9-11
MAINTENANCE .....	11-12

### SAFETY CONSIDERATIONS

Installation and servicing of air conditioning equipment can be hazardous due to system pressure and electrical components. Only trained and qualified service personnel should install, repair or service air conditioning equipment.

Untrained personnel can perform basic maintenance functions of cleaning coils and cleaning and replacing filters. All other operations should be performed by trained service personnel. When working on air conditioning equipment, observe precautions in the literature, tags and labels attached to the unit and other safety precautions that may apply.

Follow all safety codes. Wear safety glasses and work gloves. Use quenching cloth for brazing operations. Have fire extinguisher available for all brazing operations.

**WARNING:** Before performing service or maintenance operations on system, turn off main power switch to indoor unit and outdoor unit. Turn off accessory heater power switch if applicable. Electrical shock could cause personal injury.

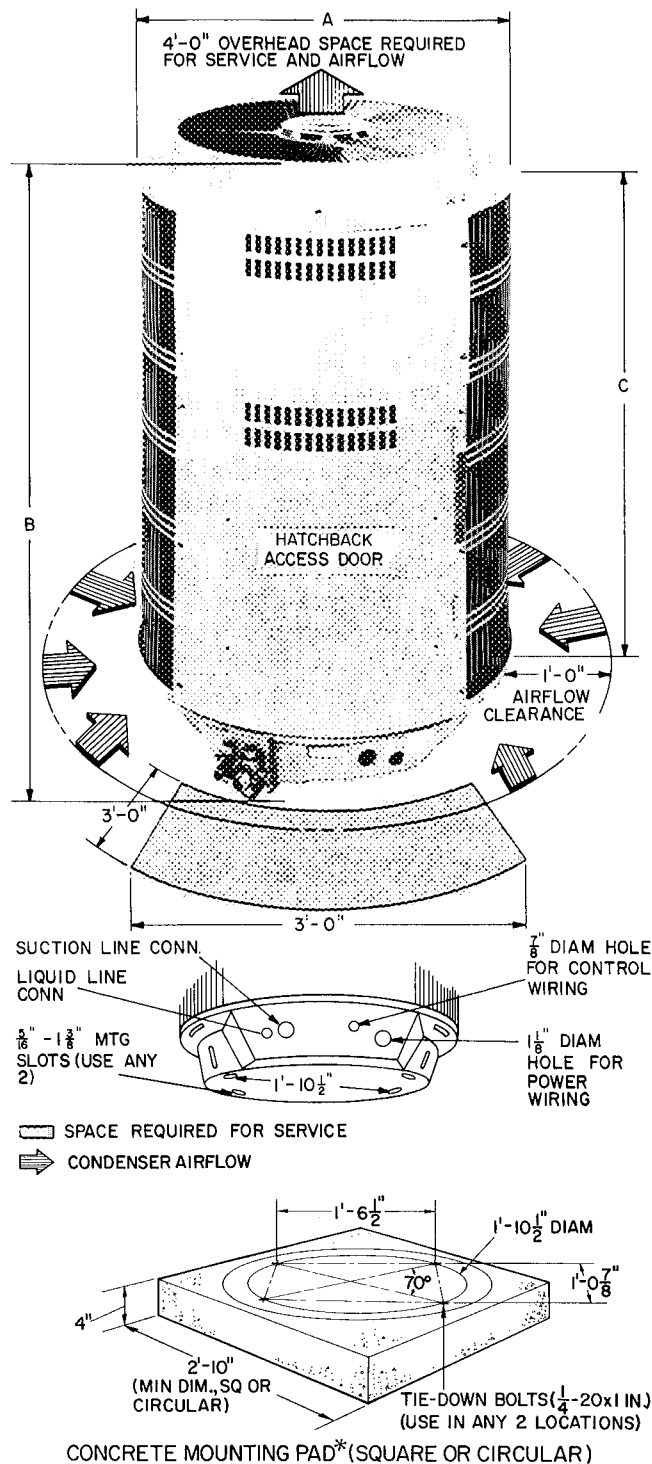

CONCRETE MOUNTING PAD\*(SQUARE OR CIRCULAR)

\*CONCRETE PAD SHOULD WEIGH 1-1/2 TO 2 TIMES WEIGHT OF UNIT

Certified dimension drawings available on request

**Fig. 1 — Dimensions, Connections and Mounting Pad**

**Table 1 — Physical Data**

MODEL 38VH	001	002	003	004	045	005
OPER WT (lb)	165	200	205	225	240	250
DIMEN. (ft.-in.)						
Diameter	A		2-5-1/4			
Unit Height	B	2- 8	3-2	3-2	3- 8	3- 8
Coil Height	C	1-11	2-5	2-5	2-11	2-11
REFRIG CONN*						
Suction (in. ODF)	5/8	3/4	3/4	3/4	3/4	3/4
Liquid (in. ODF)	3/8					

\*All models except 38VH001 are supplied with a 3/4-in to 1-1/8 in suction valve connection adapter (field installed) for 1-1/8 in suction line (field supplied)

**INSTALLATION**

**Step 1 — Check Equipment and Jobsite**

**UNPACKAGE UNIT** — Move to final location. Slide from carton taking special care not to damage service valves or grilles.

**INSPECT EQUIPMENT** — File claim with shipping company if damaged or incomplete.

**COMPLETE OR CONSIDER SYSTEM REQUIREMENTS** before installation:

Consult local building codes and National Electrical Code (NEC) for special installation requirements.

When installing, allow sufficient space for airflow clearance, wiring, refrigerant piping and service. Recommended space minimum requirements are: overhead — 4 ft, perimeter — 3 ft (Fig. 1). Position so water from roof or eaves does not pour directly on unit.

Install on a solid, level mounting pad. Position tie-down bolts in pad. Any 2 holes in unit base may be used to fasten unit to pad.

Carrier Cooling System Capacity Optimization may require field replacement of piston in AccuRater™ (bypass type) refrigerant control supplied on evaporator. See Table 2. Enter table at cooling system Outdoor Air Design Temperature closest to that of locality. Find AccuRater Piston number required for condenser/evaporator system being installed. Piston change is not necessary if table indicates that required piston is factory installed in evaporator coil.

When evaporator is more than one size larger than condensing unit (i.e. 38VH002/28AR036), remove AccuRater and use a bleed-type thermal expansion valve (TXV) for refrigerant control. Size TXV to nominal capacity of condensing unit.

A replacement AccuRater piston is factory supplied on Models 38VH001,002,003 and 004. This piston is correctly sized for an evaporator of the same capacity as the condensing unit at an outdoor air design temperature of 95 F. Mix-matching and outdoor air design temperatures other than 95 F may require another piston number or thermal expansion valve. (Refer to Table 2.)

Replace piston as required before connecting refrigerant lines. Bypass type AccuRater components are shown in Fig. 2. Piston replacement

**Table 2 — Optimization Chart**

OUTDOOR AIR DESIGN TEMP (F)	COND UNIT 38VH	ACCURATER™ PISTON NO.						
		Evap Size (Coil or Fan-Coil Excluding Model 28VH, See Below)						
		018	024	030	036	042	048	060
100	001	52	52	TXV	—	—	—	—
	002	—	55	57	TXV	—	—	—
	003	—	—	62	65	TXV	—	—
	004	—	—	—	70	73	TXV	—
	005	—	—	—	—	73	73	TXV
95 (ARI Test Condition)	001	52	53	TXV	—	—	—	—
	002	—	57	59	TXV	—	—	—
	003	—	—	65	67	TXV	—	—
	004	—	—	—	73	76	TXV	—
	005	—	—	—	—	76	76	TXV
91	001	52	53	TXV	—	—	—	—
	002	—	57	59	TXV	—	—	—
	003	—	—	65	67	TXV	—	—
	004	—	—	—	73	76	TXV	—
	005	—	—	—	—	76	76	TXV
87 (and below)	001	55	55	TXV	—	—	—	—
	002	—	59	61	TXV	—	—	—
	003	—	—	65	70	TXV	—	—
	004	—	—	—	76	76	TXV	—
	005	—	—	—	—	78	78	TXV
		28VH002*			28VH004*			
	002	63			—			
	003	—			70†			
	004	—			75			

Standard factory-installed AccuRater piston  
 \*The 28VH piston designations are applicable to full temperature range  
 †Size 70 piston factory supplied with 28VH004  
 NOTE: Piston numbers effective December 1, 1979

instructions are included in evaporator Installation book. After system installation is complete, use Chargemaster charging device or charging chart to check and/or adjust refrigerant charge.

Condensing Units Connected to Carrier-Approved Evaporators — Condensing units contain correct system refrigerant charge for operation with evaporator of same size when they are connected by 50 ft of field-supplied tubing of recommended size (see Piping Connections) or 50 ft or less of Carrier accessory tubing. Check refrigerant charge for maximum system efficiency. See Refrigerant Charging for details.

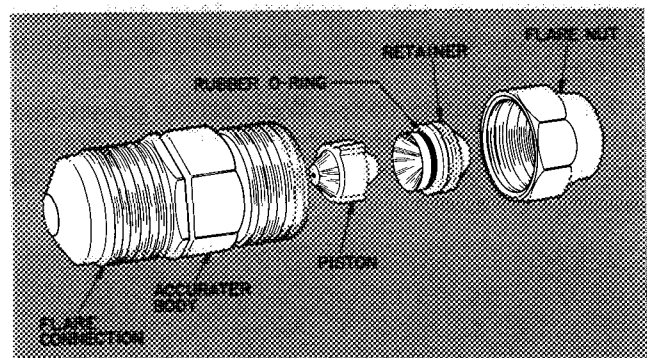

**Fig. 2 — AccuRater (Bypass Type) Components**

**Condensing Units Connected to Non-Carrier Evaporators** — Check refrigerant charge when the condensing unit is added to a system in which other than a Carrier-approved evaporator is to be used or where the evaporator has been previously installed. Check that field-supplied refrigerant piping is in accordance with refrigerant piping data (Table 3).

**Step 2 — Make Tubing Connections** — Condensing units may be connected to evaporator sections using Carrier accessory tubing package or field-supplied tubing of refrigerant grade. See Table 4 for accessory tubing sizes. Table 3 for recommended field-supplied tubing sizes.

**WARNING: DO NOT BURY LINESETS.** If system is inoperative for extended periods during warm weather, refrigerant may migrate to the cooler buried section causing slugging at start-up.

Isolate interconnecting tubing from framing and ductwork or where tubing runs thru stud spaces, enclosed ceilings or pipe chases. Use isolation type hanger (Fig. 3) since rigid fastening transmits pulsations to structure creating objectionable sound.

A capacity and efficiency reduction results if undersized Carrier accessory tubing is used in 38VH systems. (Example: When a 25-ft accessory tubing

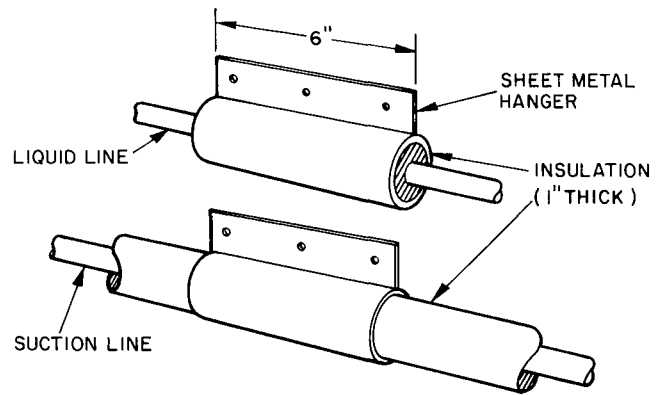

**Fig. 3 — Refrigerant Line Hangers**

package is used on a 38VH004 system, the smaller suction line will result in a capacity reduction of 3%.) For maximum capacity and efficiency from this system, use suction line recommended in Table 3.

Length of interconnecting tubing may necessitate refrigerant charge adjustment. Follow special requirements described in Initial Start-Up, Refrigerant Charging. *Do not use less than 10 ft of interconnecting tubing.* On Carrier accessory tubing packages, do not cut 5/16-in. or 1/4-in. liquid line or 7/8-in. suction line. These tubing packages have swaged ends. If swage at end of tubing is cut off, the tubing will not fit into unit refrigerant line fittings. Bend or coil excess tubing to fit.

**Table 3 — Field-Supplied Tubing Data**

**NOTES**

- 1 Maximum allowable vertical separation for evaporator over the condensing unit is 50 feet
- 2 Over 50-ft vertical separation, the condensing unit must be located above evaporator
- 3 The maximum total tubing length between units is 150 feet

- 4 All suction tubing must be insulated with 3/8-in thick, flexible foam tubing (Armaflex 22 or equivalent)
- 5 Piston numbers effective December 1, 1979

Vertical separation from 51 to 100 feet (Condensing unit above evaporator)

COND UNIT 38VH	EVAP SIZE	REFRIGERANT LINE LENGTH (ft)						Indoor Piston
		10 to 50 ft			51 to 150 ft			
		Line Diameter						
		Suction (in.)	Liquid (in.)	Indoor Piston*	Suction (in.)	Liquid (in.)	Indoor Piston*	
001	018	5/8	3/8	52	3/4	5/16	52	46
	024	5/8	3/8	52	3/4	5/16	52	46
	030	5/8	3/8	TXV	3/4	5/16	TXV	TXV
002	024	7/8	3/8	57	7/8	5/16	57	52
	030	7/8	3/8	59	7/8	5/16	59	55
	036	7/8	3/8	TXV	7/8	5/16	TXV	TXV
003	030	7/8	3/8	63	1-1/8	5/16	63	59
	036	7/8	3/8	65	1-1/8	5/16	65	59
	042	7/8	3/8	TXV	1-1/8	5/16	TXV	TXV
004	036	1-1/8	3/8	76	1-1/8	5/16	76	70
	042	1-1/8	3/8	78	1-1/8	5/16	78	73
	048	1-1/8	3/8	TXV	1-1/8	5/16	TXV	TXV
045	042	1-1/8	3/8	76	1-1/8	3/8	76	70
	048	1-1/8	3/8	78	1-1/8	3/8	78	73
	060	1-1/8	3/8	TXV	1-1/8	3/8	TXV	TXV
005	048	1-1/8	3/8	82	1-1/8	3/8	82	76
	060	1-1/8	3/8	84	1-1/8	3/8	84	78
002	28VH002	1-1/8	3/8	63	1-1/8	5/16	63	59
003	28VH004	1-1/8	3/8	70	1-1/8	5/16	70	65
004	28VH004	1-1/8	3/8	78	1-1/8	5/16	78	73

\*At 95 F outdoor air design temperature. At other design temperatures, piston sizes may vary. See Table 2.

**Table 4 — Accessories**

PART NO.	DESCRIPTION	UNIT
HH01AD040	Low-Voltage Control — Honeywell Deluxe Thermostat	All
HH93AZ040	Thermostat Subbase	
HH51AR001	Comfort Control Center (Use with HH01AD040)	
HH07AT070	Low-Voltage Control — Honeywell Thermostat	
HH07AT074	Thermostat Subbase (with Automatic Changeover)	
HH01AD042	Low-Voltage Control — Honeywell Thermostat	
HH93AZ042	Thermostat Subbase	
HH01YA092	Low-Voltage Control — Grayson Thermostat	
HH93YZ094	Thermostat Subbase	
38GS900102	Indoor Fan Relay (Six HN61KJ210)	
38GS900212	Low-Voltage Transformer (Six 38GS900091)	38VH003,004, 045,005
38HQ900011	Hot Shot — domestic water pre-heater	
38UE900001	Chillermate refrigerant-to-water heat exchanger	38VH002,003,004, 045,005
32LT900301	Motormaster® Head Pressure Control Special field-installed fan motor HC42VE233 required	All
38GS900321	Liquid Line Filter-Drier (Six 38GS900332)	All

TUBING PACKAGES	TUBING*						UNIT
	Length (ft)	Liquid		Suction†			
		OD (in.)	Tube End OD (in.)	OD (in.)	Tube End, OD (in.)		
				Evap	Cond		
38LS958151	15	3/8	3/8	5/8	3/4‡	5/8	38VH001
38LS958201	20	3/8	3/8	5/8	3/4‡	5/8	38VH002
38LS958251	25	3/8	3/8	5/8	3/4‡	5/8	38VH001
38LS958301	30	5/16	3/8	5/8	3/4‡	5/8	
38LS958351	35	5/16	3/8	5/8	3/4‡	5/8	
38LS958401	40	5/16	3/8	5/8	3/4‡	5/8	
38LS958501	50	1/4	3/8	5/8	3/4‡	5/8	
38LS934251	25	3/8	3/8	3/4	3/4	3/4	38VH002
38LS934301	30	3/8	3/8	3/4	3/4	3/4	
38LS934351	35	3/8	3/8	3/4	3/4	3/4	
38LS934401	40	3/8	3/8	3/4	3/4	3/4	
38LS934501	50	3/8	3/8	3/4	3/4	3/4	
38LS978151	15	3/8	3/8	7/8	3/4	3/4	38VH003
38LS978201	20	3/8	3/8	7/8	3/4	3/4	38VH004
38LS978251	25	3/8	3/8	7/8	3/4	3/4	38VH045
38LS978301	30	3/8	3/8	7/8	3/4	3/4	38VH005
38LS978351	35	3/8	3/8	7/8	3/4	3/4	(See Note 2)
38LS978401	40	3/8	3/8	7/8	3/4	3/4	
38LS978501	50	3/8	3/8	7/8	3/4	3/4	

\*For maximum capacities, use suction line sizes recommended in Table 3. If accessory tubing package is used on 38VH004,045,005 units, a reduction in capacity can result. Field-supplied 1-1/8 in. suction line is recommended with all 28VH coil installations.

†Suction line is insulated and has a 90 degree bend at one end  
‡For 5/8-in. evaporator connection, cut off 3/4-in. end  
NOTE Do not cut 3/8-in. OD liquid lines to a length shorter than 10 feet. Do not cut 5/16- or 1/4-in. liquid line. Do not cut 7/8-in. OD suction lines.

Do not use damaged or contaminated tubing. Always evacuate or purge evaporator coil and tubing system. When purging, use field-supplied refrigerant, not unit holding charge refrigerant.

When making tubing connections, be sure to provide clearance at unit for electrical connections.

REPLACE THE ACCURATER™ REFRIGERANT CONTROL PISTON IN THE INDOOR COIL, if required, before connecting refrigerant lines. See Carrier Cooling System Optimization, page 2.

CONNECT REFRIGERANT LINES to fittings on condensing unit suction and liquid service valves

(Fig. 1). Unit Compatible Fittings permit mechanical (quick connect) or sweat connections.

**Models 38VH002,003,004,045,005** — When using 1-1/8 in. field-supplied suction line, remove suction line adapter taped to compressor suction line. Sweat connect refrigerant suction line to 1-1/8 in. end of adapter. Be sure to provide a heat sink at the service valve to prevent damage during sweating operation. Connect 3/4-in. end of adapter to unit suction line Compatible Fitting. Connect liquid refrigerant line to unit. When a 7/8-in. field-supplied suction line is used, provide a field-supplied 3/4-in. to 7/8-in. suction line adapter. (Not necessary if 38LS accessory tubing is used.)

Table 5 — Electrical Data

COND UNIT 38VH	V/PH	OPER VOLTS*		COMPR		FAN	BRANCH CIRCUIT					
		Max	Min	LRA	RLA	FLA	Min Wire Size† (AWG)		Max Ft Wire†		Min Gnd Wire Size	Fuse Amps‡
001	208-230/1	253	197	40.6	6.9	9	14	12	37	59	12	15
002				49.0	10.3	9	14	12	26	41	12	25
003				69.0	15.4	9	12	10	28	44	10	35
004				83.5	17.9	1.2	10	8	38	59	8	40
045				88.0	17.1	1.2	10	8	39	62	8	35
005	230/1	253	207	97.0	22.4	2.3	10	8	32	51	8	50

Corresponding wire sizes and wire lengths

FLA — Full Load Amps  
LRA — Locked Rotor Amps  
RLA — Rated Load Amps

\*Permissible limits of the voltage range at which the unit will operate satisfactorily

†Copper wire sizes and lengths

‡Maximum dual element size

NOTE: Control circuit is 24-v on all units and requires external power source

**Mechanical Connection** — (Mate one set of connections at a time.)

- Loosen nut on Compatible Fitting one turn. Do not remove.
- Remove plug and be sure O-ring is in the groove inside the Compatible Fitting.
- Cut tubing to correct length, deburr and size as necessary.
- Insert tube into Compatible Fitting until it "bottoms." Tighten nut until it bottoms on back coupling flange. Keep tube bottomed in Compatible Fitting while tightening nut.

**Sweat Connection** — (Use refrigerant grade tubing.)

- Remove locking nut, rubber O-ring and Schraeder core and cap from valve service port.
- Cut tubing to correct length, deburr and size as necessary.
- Insert tube in Compatible Fitting until it "bottoms." Wrap top and bottom of service valves in wet cloth to prevent damage by heat. Solder with low-temperature (450 F) silver alloy solder.
- Replace Schraeder core and cap.
- Evacuate or purge system using field-supplied refrigerant.

**Step 3 — Make Electrical Connections** — Be sure field wiring complies with local and national fire, safety and electrical codes, and that voltage to unit is within limits shown in Table 5. Contact local power company for correction of improper line voltage.

Operation of unit on improper line voltage constitutes abuse and could affect Carrier Warranty. See Table 5. Do not apply unit in system where voltage may fluctuate above or below permissible limits.

See Table 5 for recommended wire and fuse sizes. When making electric connections, provide clearance at unit for refrigerant piping connections.

**INSTALL A BRANCH CIRCUIT DISCONNECT PER N.E.C.** of adequate size to handle unit starting current. Locate disconnect within sight of and readily accessible to the unit, per section 440-14 of National Electrical Code (NEC).

**ROUTE LINE POWER LEADS INTO UNIT** — Extend leads from disconnect thru hole provided in basepan (Fig. 1) and into unit junction box.

**CONNECT GROUND LEAD AND POWER WIRING** — Connect ground lead to a ground lug in control box for safety. Then connect power wiring. See Fig. 4. Splice line power leads to yellow and black pigtails. Use wire nuts and tape at each connection.

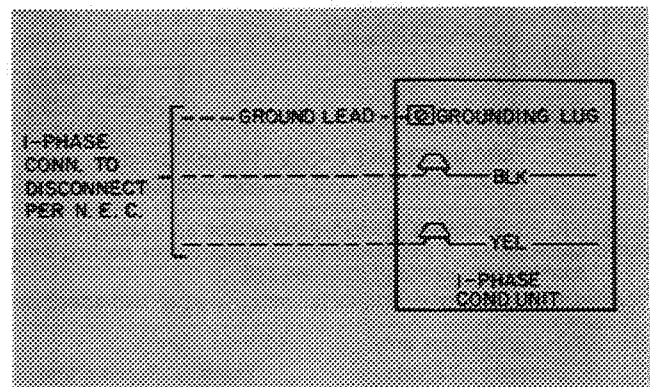

Splice Connections  
Field Wiring  
Factory Wiring

Fig. 4 — Line Power Connections

THERMOSTAT SUBBASE  
HH93AZ042 OR  
HH93AZ040

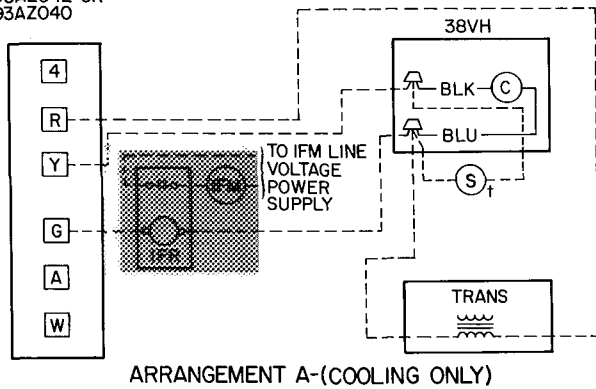

THERMOSTAT SUBBASE  
HH93AZ042 OR  
HH93AZ040

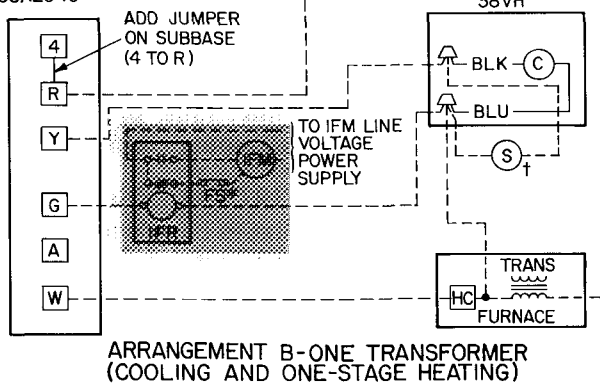

THERMOSTAT SUBBASE  
HH93AZ076

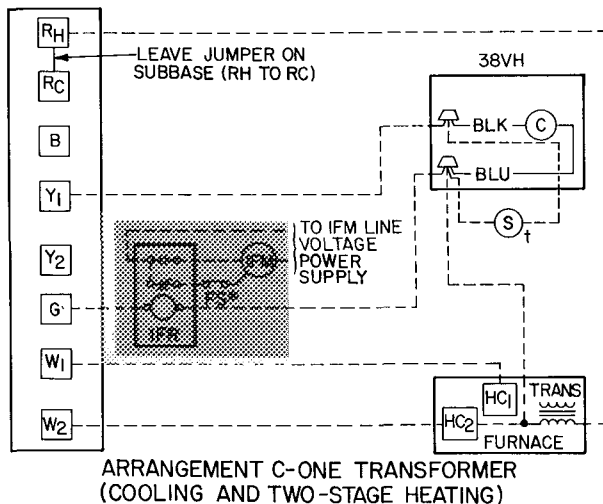

IFR, FS and IFM are located in furnace on heating-cooling applications. If accessory IFR is required for cooling only applications, locate (IFR) in fan coil

\*Connect FS to low-speed indoor fan terminal when two-speed fan is used

†For 28VH applications only

**C** — Contactor (12 va)  
**FS** — Fan Switch  
**HC** — Heating Control  
**IFM** — Indoor Fan Motor  
**IFR** — Indoor Fan Relay  
**S** — Solenoid

**Trans** — Transformer  
 — Field Splice  
 — Field Wiring  
 — Factory Wiring

• Fig. 5 — Control Circuit Connections

**CONNECT CONTROL POWER WIRING** — Route 24-v control wires thru hole in unit basepan and into low-voltage section of unit junction box (Fig. 1). Splice control leads to black and blue pigtails on all units. See Fig. 5. Use at least 18 ga. control wire. Use furnace or fan-coil transformer as 24-v (40-va minimum) supply for system as shown in Fig. 5, or, use accessory transformer shown in Table 4.

When using 28VH coil, special wiring provisions must be followed. See 28VH Installation, Start-Up and Service Instructions for details.

### START-UP

1. Backseat (open) liquid and suction line service valves.
2. Set thermostat selector switch at OFF.
3. Set room thermostat at desired temperature. Be sure this temperature is below indoor ambient.
4. Close electrical disconnects energizing entire system.
5. Set room thermostat at COOL and fan switch at Fan or AUTO, as desired. Solid state Time Guard® device prevents unit from starting for up to 5 minutes after thermostat closes (See Service, Solid State Time Guard Circuit.) Operate unit for 15 minutes; then check system refrigerant charge. See Service, Refrigerant Charge, discussed later.

Motors and controls are designed to operate satisfactorily in the voltage range shown in Table 5. If necessary to use manifold gages for servicing, refer to Carrier Standard Service Techniques Manual, Chapter 1, Refrigerants, page 1-5, Fig. 8 for bypass method of returning charge to system. Removal of liquid line charging hose without following these precautions could result in some loss of charge.

### Refrigerant Charging

**CAUTION:** To prevent personal injury, wear safety glasses and gloves when handling refrigerant.

Do not overcharge system. An overcharge can cause compressor flooding.

Condensing units contain correct operating charge for complete system when connected to Carrier-approved evaporators (excluding 28VH applications, see "Weight Method — 28VH Applications") of same capacity as condensing unit and have 50 ft or less of Carrier accessory tubing or field-supplied tubing of recommended size. For every 10 ft of liquid line of recommended size over 50 ft, add refrigerant charge as follows: .4 lb for 3/8-in. line; .28 lb for 5/16-in. line. On all other systems, adjust charge for correct operation as applicable.

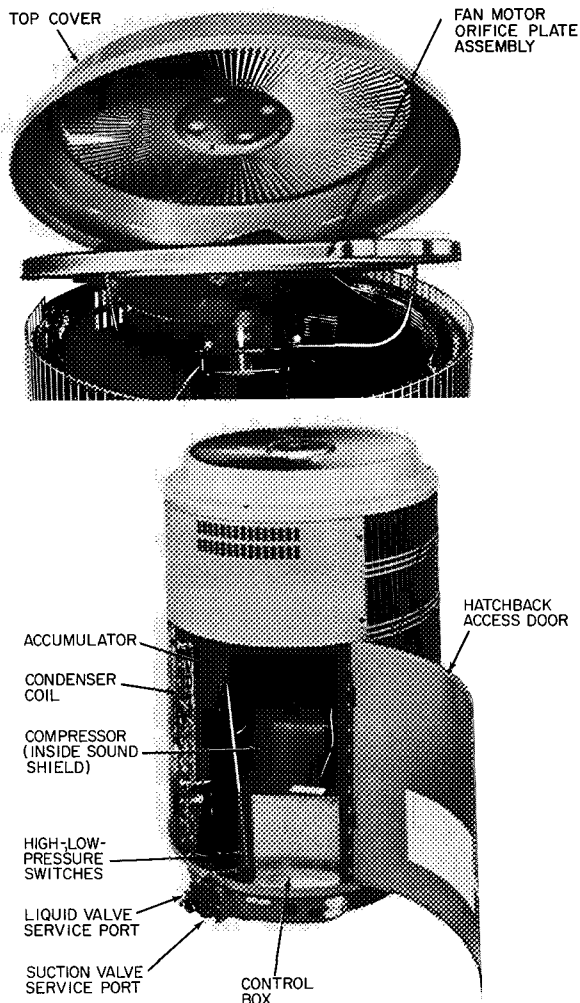

**Fig. 6 — Condensing Unit 38VH with Access Door Open**

**Table 6 — Service Data**

UNIT 38VH†	R-22 CHG*		CONDENSER FAN			
	Lbs†	Lbs-Oz†	Low Speed		High Speed	
			Rpm	Cfm	Rpm	Cfm
001	5.5	5-8	650	2300	800	2800
002	10.3	10-5	750	2300	900	2800
003	9.1	9-2	750	2300	900	2800
004	9.2	9-3	750	2650	900	3200
045	9.2	9-3	750	2650	900	3200
005	8.1	8-2	850	3150	1050	3900

\*Factory refrigerant charge is adequate when evaporator and condensing unit are same size, and are connected with 25 ft or less of field-supplied tubing of recommended size or 50 ft or less of Carrier accessory tubing

†Not to be used for 28VH applications See "Weight Method — 28VH Applications"

**Table 7 — Refrigerant Charging Methods**

COND UNIT 38VH †	METHODS OF CHECKING OR ADJUSTING CHARGE		METHODS FOR COMPLETE RECHARGING	
	System Refrigerant Control		System Refrigerant Control	
	Non TXV	TXV	Non TXV	TXV
001,002 003,004 045,005	Chargemaster or Charging Chart	Sight Glass*	Weight Method plus Chargemaster or Charging Chart	Weight Method plus Sight Glass*

\*Sight glass field supplied and installed in liquid refrigerant line

†Not to be used for 28VH applications See "Weight Method — 28VH Applications"

On systems having field piping in excess of 50 ft, add refrigerant and oil as shown in Table 9.

Service port connections are provided on liquid and suction line service valves for evacuation and charging. See Fig. 6.

**TO CHECK, ADJUST OR REPLACE REFRIGERANT CHARGE** use method recommended in Table 7. Details of charging methods are listed below.

Before recharging system, thoroughly evacuate system and then weigh in refrigerant charge specified in Table 6. Check or adjust charge as required. Refer to Carrier Standard Service Techniques Manual, Chapter 1, Refrigerants, for additional system evacuation and dehydration instructions.

**WEIGHT METHOD** — Refer to Table 6 or unit nameplate for correct system refrigerant charge. Remove any refrigerant remaining in system before recharging.

When system is not evacuated, subtract the following amount from total charge.

38VH001,002	— .10 lb (1.6 oz)
38VH003,004,045,005	— .20 lb (3.2 oz)

The Dial-a-charge charging cylinder is an accurate device used to recharge systems by weight. These cylinders are available at refrigerant supply firms.

**28VH Applications** — Use of the 38VH002,003 and 004 units with matching 28VH indoor coils, for high SEER (Seasonal Energy Efficiency Ratio) performance, requires the weight method of charging. Discharge the factory charge into a proper container and weigh in the correct charge as shown below. The charge is critical for proper operation and the weight method is the recommended charging procedure.

**Charging Weights — 28VH Combinations (Refrigerant R-22)\***

SYSTEM COMBINATIONS	LBS	LBS-OZ
38VH002/28VH002	9.1	9-2
38VH003/28VH004	9.1	9-2
38VH004/28VH004	9.3	9-5

\*These charges are for 25-ft of tubing. See Refrigerant Charging, page 6, for charge variation of other than 25 feet

**CAUTION** Do not add refrigerant beyond quantity indicated by Chargemaster or charging chart. This could adversely affect system performance or reliability.

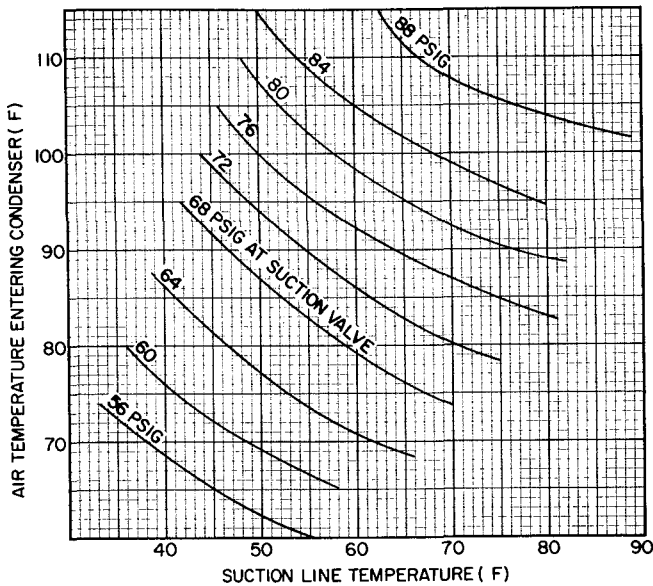

**Fig. 7 — Charging Chart (Non TXV Systems)\***

\*Not to be used for 28VH applications See "Weight Method — 28VH Applications"

**CHARGING CHART METHOD** — Use Charging Chart, Fig. 7 and the following procedure.

1. Operate unit a minimum of 10 minutes before checking charge.
2. Measure suction pressure by attaching a gage to suction valve service port.
3. Measure suction line temperature by attaching a service thermometer to unit suction line near compressor. (Insulate thermometer for accurate readings.)
4. Measure outdoor (condenser inlet) air dry-bulb temperature with a second thermometer.
5. Refer to Charging Chart (Fig. 7). Find air Temperature Entering Condenser and project horizontally to curve showing suction pressures (psig at Suction Valve).
6. From this intersection, project vertically downward to Suction Line Temperature.
7. If unit has a higher suction line temperature than charted temperature, add refrigerant until charted temperature is reached.
8. If unit has a lower suction line temperature than charted temperature, bleed refrigerant until charted temperature is reached.
9. If air temperature entering condenser or pressure at suction valve changes, charge to new suction line temperature indicated on chart.

**CHARGEMASTER® METHOD** — Operate unit for 10 minutes before using Chargemaster (Carrier part No. 38GC680004).

1. Tape Chargemaster feeler bulb to suction line close to condensing unit. Insulate bulb. Ensure suction line is clean for good contact with bulb.

- (Uninsulated bulb or dirty suction line will seriously affect accuracy of temperature readings.)
2. Connect refrigerant drum to Chargemaster inlet port keeping drum in position for vapor charging.
3. Connect Chargemaster outlet port to unit suction valve service port.
4. Crack valves on refrigerant drum and Chargemaster to purge lines from drum to suction valve. After purging lines, close valve on Chargemaster only.
5. Measure outdoor air dry-bulb temperature.
6. Crack unit suction valve and read *evaporator temperature at red needle position on Chargemaster temperature gage and suction line temperature at black needle position.*

**CAUTION:** Do not read evaporator temperature while Chargemaster valve is open.

7. Enter Chargemaster Charging Chart, Table 8, at Outdoor Air Temperature (step 5) and Evaporator Temperature (step 6). Find the Suction Line Temperature required for correct system charge. If actual suction line temperature (step 6) is higher than table value, the system is undercharged. If suction line temperature is lower than table value, system is overcharged.

**EXAMPLE:** At outdoor air temperature of 85 F and evaporator temperature of 44 F, the system will be correctly charged at 71 F  $\pm$  2 F suction line temperature. See Table 8.

**Table 8 — Chargemaster Charging Chart (Non TXV Systems)†**

OUTDOOR TEMP (F)	EVAPORATOR TEMP (F)*											
	32	34	36	38	40	42	44	46	48	50	52	54
	Suction Line Temperature ( $\pm$ 2 F)											
60	60											
65	49	58	65									
70	41	48	58	68	70							
75	35	41	48	58	68	75						
80	32	36	42	50	59	63	80					
85			38	44	52	60	71	82				
90				40	47	53	61	69	78			
95					42	48	53	59	67	79		
100						43	47	52	58	68	88	
105							44	48	53	60	75	104
110								49	54	65	80	
115									50	62	69	

Example

\*Saturated evaporator temperature which is the equivalent temperature of pressure taken at the condensing unit suction service valve

†Not to be used for 28VH applications See "Weight Method — 28VH Applications"



8. Add charge by slowly opening Chargemaster valve. If necessary, reduce charge by bleeding at liquid line service valve. Check outdoor air and evaporator temperature during procedure. If they change, refer back to Chargemaster Charging Chart.

Correct use of Chargemaster ensures that an optimum refrigerant charge will be in system when conditions and system components are "normal." However, the Chargemaster does not solve or fix systems abnormalities. It indicates correct charge for condition of the system. It will not make corrections for dirty filters, slow fans, excessively long or short suction lines or other abnormal conditions. This charging device ensures that a correct relationship exists between outdoor temperature, evaporator temperature, and suction line temperature on a specific system.

**SIGHT GLASS METHOD** — (Field-supplied sight glass installed in liquid line.) A satisfactory operating charge can be obtained on *thermal expansion valve systems only* by charging to a clear sight glass. For optimum charge, increase high-side pressure to  $380 \pm 10$  psig by blocking condenser fan discharge or air entering condenser. Charge to a clear sight glass while holding constant high-side pressure. For peak efficiency, adjust charge to yield a liquid refrigerant temperature at the evaporator that is approximately the same as outdoor dry-bulb temperature.

## SERVICE

**CAUTION:** Unit has high-pressure piping which may be also hot to touch, energized electrical components and a rotating fan. Before servicing or checking unit, be sure *all* system power is off and tubing is cool.

**Compressor Removal** — See Table 9 for compressor information and Fig. 6 for component location. Shut off power to unit. Remove refrigerant from unit using refrigerant removal methods described in Carrier Standard Service Techniques Manual, Chapter 1, Refrigerants.

Follow safety codes. Wear safety glasses and work gloves. Have quenching cloth available.

**Table 9 — Compressor Data**

UNIT 38VH	V/PH	PRODUCTION COMPRESSOR*	OIL RECHARGE (oz)†	
			Typical	Additional
001	208-230/1	AH8520E ✓	24	0 25
→ 002	208-230/1	CRB1-0175-PFV ✓	51	0 5
003	208-230/1	CRF1-0250-PFV ✓	51	0 5
004	208-230/1	CRH1-0275-PFV ✓	51	0 5
045	208-230/1	AH8543E ✓	42	0 5
005	230/1	PC5016BD ✓	72	1 0

\*Refer to Carrier Service Parts Catalog for replacement compressor model numbers

†"Typical" refers to systems having refrigerant piping up to 50 ft long. Where piping exceeds 50 ft add additional quantity of oil shown for *each* 10 ft beyond 50 feet

**CAUTION:** Aluminum tubing is used in unit coils. Do not overheat or place excessive strain on tubing or damage may result.

1. Turn off power to unit. Failure to do so may result in electric shock. Open door and remove top access panel if so equipped. See Fig. 6.
2. Remove unit top cover. Remove 6 screws holding fan motor orifice assembly in place. Lift assembly and position it near unit being careful not to strain fan motor ends.
3. Compressor sound shield is snapped together. Undo those snaps which are under piping connections, then lift the assembly off the compressor.
4. Remove compressor terminal box cover. Disconnect and remove compressor power leads.
5. Be sure refrigerant has been removed so that system pressure is 0 psig.
6. Using a tubing cutter, cut suction and discharge lines at convenient place near compressor to allow easy reassembly to new compressor by using field-supplied copper coupling connected at these points.

**CAUTION:** Excessive movement of copper lines at compressor may cause a break where lines connect to condenser coil.

7. Remove compressor hold-down bolts. Lift out compressor thru front of unit.
8. Carefully unbraze suction and discharge line piping stubs from compressor. If oil vapor in piping stubs ignites, use quenching cloth.
9. Braze piping stubs (removed in Step 7) onto new compressor.
10. Install new compressor in unit. Have fire extinguisher and/or quenching cloth available in case oil vapor ignites. Braze suction and discharge lines to compressor piping stubs (at points where cut, Step 6) using field-supplied copper couplings. Replace compressor hold-down bolts. Reconnect wiring.
11. Clean system. If a compressor failure was caused by a major motor-winding burnout, contaminants (burnout by-products) can cause future system operating problems if left in system. Install a filter-drier in the suction line near the compressor. Also install a drier in the liquid line ahead of the refrigerant control device. Run unit for 48 hours to remove contaminants. Remove suction line filter-drier and liquid line drier. Discard both driers. Clean AccuRater™ refrigerant control as described in evaporator installation instructions. Install new liquid line filter-drier. If burnout was minor, install or replace liquid line filter-drier, run for 48 hours, then discard filter-drier. Install new filter-drier.

12. Triple-evacuate system. Recharge system as described previously.

**Filter-Drier** — Install field-supplied filter-drier (Table 4) in system liquid line when refrigerant system is opened for service as described under Compressor Removal. Position drier in liquid line at convenient location.

**Pumpdown Procedure** — The system may be pumped down in order to make repairs on low side without losing complete refrigerant charge.

1. Attach pressure gage to suction service valve gage port.
2. Frontseat the liquid line valve.
3. Start unit and run until suction pressure reaches 5 psig (see Caution).
4. Shut unit off and frontseat suction valve.
5. Vent remaining pressure to atmosphere.

**CAUTION:** The condensers will hold only factory-supplied amount of refrigerant. Additional refrigerant may cause units to shut off on high-pressure switch cut-out during pumpdown (indicated by a high discharge pressure or a sudden rise of suction pressure) before suction pressure reaches 5 psig. If this occurs, shut unit off immediately and frontseat suction valve. Transfer remaining refrigerant into a suitable container.

### Unit Controls and Safety Devices

**HIGH-PRESSURE RELIEF VALVE**, when equipped, is located in compressor. Relief valve opens if system operating pressure differential between suction and discharge pressure reaches 500 psi on all models.

**HIGH-PRESSURE SWITCH** is located on unit liquid line. High-pressure switch settings are: cut-out,  $425 \pm 5$  psig; cut-in,  $320 \pm 20$  psig.

**LOW-PRESSURE SWITCH** is located on unit suction line. Low-pressure switch settings are: cutout,  $31 \pm 4$  psig; cut-in,  $60 (+15, -0)$  psig.

**INTERNAL TEMPERATURE AND/OR CURRENT SENSITIVE OVERLOADS** reset automatically when motor internal temperatures drop to a safe level (overload may require up to 30 minutes to reset). When internal overload is suspected of being open, check by using an ohmmeter or continuity tester. If necessary, refer to Carrier Standard Service Techniques Manual, Chapter 2, Electrical, for complete instructions.

**INHERENT FAN MOTOR PROTECTION** — Protects motor from abnormal current and temperature.

**SOLID STATE TIME GUARD® CIRCUIT** protects unit compressor by preventing short cycling. Time Guard provides a  $5 \pm 2$ -minute delay before restarting compressor after shutdown for any

reason. On normal start-up, the 5-minute delay occurs before thermostat closes. After thermostat closes, the Time Guard then provides a 3-second delay to prevent contactor chattering.

**CRANKCASE HEATER SWITCH** — The purpose of the heater is to keep the crankcase warm during the off cycle and thus prevent dilution of the oil with refrigerant. This assures good lubrication and prevents loss of oil from crankcase during start-up. Switch closes (activates) at 65 F on coil temperature drop. Opens (deactivates) at 85 F on coil temperature rise.

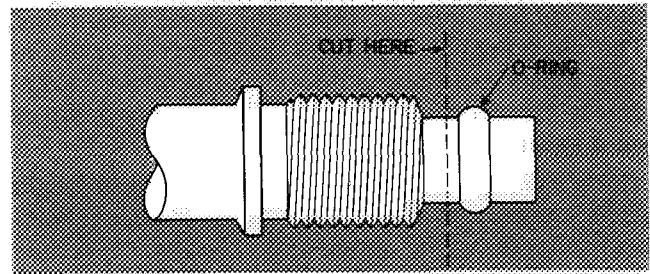

Fig. 8 — Repair of Mechanical Connection

### Compatible Fitting Repair

**MECHANICAL CONNECTION** — Frontseat unit service valves. Relieve refrigerant pressure from tubing. Back off locknut from Compatible Fitting onto tube. Cut fitting between threads and seal ring head as shown in Fig. 8. Remove tubing section remaining in threaded portion of fitting. Discard locknut.

Clean, flux, and insert new tube end into remaining portion of Compatible Fitting. *Wrap valve base in wet rag.* Heat and apply low-temperature (450 F) solder.

**SWEAT CONNECTION** — Frontseat unit service valves. Relieve refrigerant pressure from tubing. Clean and flux area around leak. Repair using low-temperature (450 F) solder.

Evacuate or purge evaporator coil and tubing system. Add refrigerant charge. See Refrigerant Charging instructions described previously.

**Condenser Fan Adjustment** — Required fan position is shown in Fig. 9. Adjust fan by loosening setscrew(s) and moving fan blades up or down.

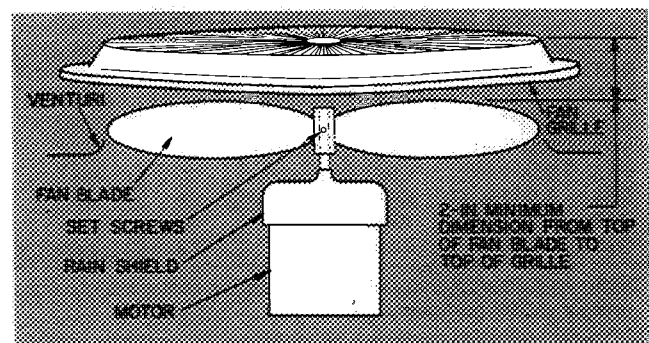

Fig. 9 — Condenser Fan Position

### Condenser Fan Motor Removal

1. Shut off power to unit. Failure to do so may result in electric shock.
2. Remove unit top cover. Open access door. Then open control box cover.
3. Disconnect fan motor leads (3) at control box. See Fig. 6.
4. Remove fan from motor shaft by loosening setscrew(s) and pulling upward on fan hub.
5. Remove 3 bolts holding fan motor to motor mounting bracket. Remove motor and leads thru top of unit.
6. Reassembly is the reverse of the above procedure. Before replacing fan, be sure rain shield (Fig. 9) is in proper position on motor shaft.

### MAINTENANCE

**CAUTION:** Before performing recommended maintenance, be sure unit main power switch is turned off. Failure to do so may result in electric shock.

### Lubrication

FAN MOTOR BEARINGS are prelubricated for 3 years heavy duty or 5 years normal duty. When lubrication is necessary, send motor to authorized motor repair shop.

COMPRESSOR contains factory oil charge. If oil requires replenishment, see Table 9 for oil recharge and Carrier Standard Service Techniques Manual, Chapter 1, Refrigerants, page 1-21, for instructions. Use Carrier PP33-1, Texaco Capella B or Suniso 3G oil.

**Coil Cleaning** — *Ensure power to unit is shut off.* Clean the condensing unit coil with water at the beginning of every cooling season or more often if required. Use ordinary garden hose at a pressure high enough to clean efficiently. For best results, unscrew and remove unit top cover. Insert hose nozzle between fan blades, spray coil fins from inside-to-outside the unit. If unit has a double-row coil, loosen screws to separate coils, *carefully* pull outer row of coils away from inner row, and flush dirt toward outside of both coils. Flush dirt from basepan by spraying water thru top of unit. Avoid splashing mud on coil or water on the fan motor.

## TROUBLESHOOTING GUIDE

SYMPTOM AND PROBABLE CAUSE	PROBABLE REMEDY
<p><b>COMPRESSOR SHUTS OFF, FAN OVERLOAD OR HIGH PRESSURE SWITCH CUT OUT, OR INTERNAL PRESSURE RELIEF OPENS</b></p> <p><b>Condenser Fan On</b></p> <ol style="list-style-type: none"> <li>1 Condenser air restricted or recirculating</li> <li>2 Refrigerant overcharge, noncondensables in system system restricted</li> <li>3 Improper line voltage, loose electrical connections, faulty run capacitor</li> </ol> <p><b>Condenser Fan Off</b></p> <ol style="list-style-type: none"> <li>1 Fan slipping on shaft, fan motor bearing stuck, fan motor defective.</li> <li>2 Loose electrical connections Fan motor overload open</li> </ol>	<ol style="list-style-type: none"> <li>1 Condenser coil blocked Maintenance, Coil Cleaning Check airflow clearance (Fig 1)</li> <li>2 Review Refrigerant Charging procedures, purge system, replace filter-drier, check refrigerant control</li> <li>3 Review Installation, Step 3, replace capacitor</li> </ol> <ol style="list-style-type: none"> <li>1 Tighten fan hub setscrews, see Condenser Fan Motor Removal</li> <li>2 Check unit wiring Check motor bearings Replace motor</li> </ol>
<p><b>COMPRESSOR RUNS BUT COOLING IS INSUFFICIENT</b></p> <ol style="list-style-type: none"> <li>1 Low refrigerant charge.</li> <li>2 Dirty filters, partially restricts airflow (evaporator coil may be partially iced).</li> </ol> <p><b>High Suction Pressure</b></p> <ol style="list-style-type: none"> <li>1. Defective compressor valves (accompanied by low head pressure)</li> </ol>	<ol style="list-style-type: none"> <li>1. Check Refrigerant Charging procedures</li> <li>2 Check evaporator air system for dirty filters, obstruction in ductwork, improper damper settings. Refer to coil, fan coil or furnace instructions as applicable.</li> </ol> <ol style="list-style-type: none"> <li>1. Perform Compressor Replacement procedure. Recheck system charge.</li> </ol>
<p><b>COMPRESSOR SHUTS OFF FROM LOW-PRESSURE SWITCH CUTOUT</b></p> <p><b>Evaporator Fan Runs</b></p> <ol style="list-style-type: none"> <li>1 Low refrigerant charge or restricted evaporator air</li> <li>2 Restricted refrigerant flow.</li> </ol> <p><b>Evaporator Fan Stopped</b></p> <ol style="list-style-type: none"> <li>1 Evaporator fan-motor defective or inoperative.</li> </ol>	<ol style="list-style-type: none"> <li>1. See Compressor Runs But Cooling Is Insufficient above regarding filters, ductwork, etc.</li> <li>2 Check refrigerant flow device, be sure correct AccuRater™ or TXV is used.</li> </ol> <ol style="list-style-type: none"> <li>1. Check furnace or fan instructions regarding defective fan relay, belt adjustment, condition of motor bearings and overloads, check and tighten electrical connections, check power supply.</li> </ol>
<p><b>COMPRESSOR SHUTS OFF, WILL NOT RESTART</b></p> <p><b>Contactors Open</b></p> <ol style="list-style-type: none"> <li>1 Burned out transformer, open thermostat circuit, faulty control relay, open overload</li> </ol> <p><b>Contactors Closed or Closes Then Opens</b></p> <ol style="list-style-type: none"> <li>1 Compressor power is out, compressor motor is burned out or internal overloads are open. Time Guard® Circuit faulty</li> </ol>	<ol style="list-style-type: none"> <li>1 Check control circuit components and wiring Refer to unit label diagram, check all conditions Refer to Standard System Techniques Manual, Chapter 2, Electrical</li> </ol> <ol style="list-style-type: none"> <li>1 Check main power supply wiring Refer to Electrical Data table and label diagram Substitute Time Guard with a replacement to verify its operation Refer to Standard Service Techniques Manual, Chapter 2, Electrical</li> </ol>

For replacement items use Carrier Specified Parts.

Manufacturer reserves the right to discontinue, or change at any time, specifications or designs without notice and without incurring obligations.

## Free Manuals Download Website

<http://myh66.com>

<http://usermanuals.us>

<http://www.somanuals.com>

<http://www.4manuals.cc>

<http://www.manual-lib.com>

<http://www.404manual.com>

<http://www.luxmanual.com>

<http://aubethermostatmanual.com>

Golf course search by state

<http://golfingnear.com>

Email search by domain

<http://emailbydomain.com>

Auto manuals search

<http://auto.somanuals.com>

TV manuals search

<http://tv.somanuals.com>