

**SmartSTACK  
ELH100-12/24TX  
FAST ETHERNET HUB**

**INSTALLATION  
AND  
USER GUIDE**

9033060







Only qualified personnel should perform installation procedures.

## **NOTICE**

Cabletron Systems reserves the right to make changes in specifications and other information contained in this document without prior notice. The reader should in all cases consult Cabletron Systems to determine whether any such changes have been made.

The hardware, firmware, or software described in this manual is subject to change without notice.

IN NO EVENT SHALL CABLETRON SYSTEMS BE LIABLE FOR ANY INCIDENTAL, INDIRECT, SPECIAL, OR CONSEQUENTIAL DAMAGES WHATSOEVER (INCLUDING BUT NOT LIMITED TO LOST PROFITS) ARISING OUT OF OR RELATED TO THIS MANUAL OR THE INFORMATION CONTAINED IN IT. EVEN IF CABLETRON SYSTEMS HAS BEEN ADVISED OF, KNOWN, OR SHOULD HAVE KNOWN, THE POSSIBILITY OF SUCH DAMAGES.

© 1999 by Cabletron Systems, Inc., P.O. Box 5005, Rochester, NH 03866-5005  
All Rights Reserved  
Printed in Taiwan, R.O.C.

Order Number: 9033060 May 1999

Cabletron, Cabletron Systems, and SmartSTACK are trademarks or registered trademarks of Cabletron Systems, Inc.

Microsoft, Windows, Windows 95, Windows 98, and Windows NT are either trademarks or registered trademarks of Microsoft Corporation.

Netscape and Netscape Navigator are trademarks of Netscape Communications Corporation.

All other product names mentioned in this manual may be trademarks or registered trademarks of their respective companies.

### FCC NOTICE

This device complies with Part 15 of the FCC rules. Operation is subject to the following two conditions: (1) this device may not cause harmful interference, and (2) this device must accept any interference received, including interference that may cause undesired operation.

**NOTE:** This equipment has been tested and found to comply with the limits for a Class A digital device, pursuant to Part 15 of the FCC rules. These limits are designed to provide reasonable protection against harmful interference when the equipment is operated in a commercial environment. This equipment uses, generates, and can radiate radio frequency energy and if not installed in accordance with the operator's manual, may cause harmful interference to radio communications. Operation of this equipment in a residential area is likely to cause interference in which case the user will be required to correct the interference at his own expense.

**WARNING:** Changes or modifications made to this device which are not expressly approved by the party responsible for compliance could void the user's authority to operate the equipment.

### INDUSTRY CANADA NOTICE

This digital apparatus does not exceed the Class A limits for radio noise emissions from digital apparatus set out in the Radio Interference Regulations of the Canadian Department of Communications.

Le présent appareil numérique n'émet pas de bruits radioélectriques dépassant les limites applicables aux appareils numériques de la class A prescrites dans le Règlement sur le brouillage radioélectrique édicté par le ministère des Communications du Canada.

### VCCI NOTICE

This is a Class A product based on the standard of the Voluntary Control Council for Interference by Information Technology Equipment (VCCI). If this equipment is used in a domestic environment, radio disturbance may arise. When such trouble occurs, the user may be required to take corrective actions.

この装置は、情報処理装置等電波障害自主規制協議会（VCCI）の基準に基づくクラスA情報技術装置です。この装置を家庭環境で使用すると電波妨害を引き起こすことがあります。この場合には使用者が適切な対策を講ずるよう要求されることがあります。

---

**CABLETRON SYSTEMS, INC.  
PROGRAM LICENSE AGREEMENT**

**IMPORTANT: THIS LICENSE APPLIES FOR USE OF PRODUCT IN THE FOLLOWING GEOGRAPHICAL REGIONS:**

**CANADA**

**MEXICO**

**CENTRAL AMERICA**

**SOUTH AMERICA**

**BEFORE OPENING OR UTILIZING THE ENCLOSED PRODUCT,  
CAREFULLY READ THIS LICENSE AGREEMENT.**

This document is an agreement ("Agreement") between You, the end user, and Cabletron Systems, Inc. ("Cabletron") that sets forth your rights and obligations with respect to the Cabletron software program ("Program") in the package. The Program may be contained in firmware, chips or other media. UTILIZING THE ENCLOSED PRODUCT, YOU ARE AGREEING TO BECOME BOUND BY THE TERMS OF THIS AGREEMENT, WHICH INCLUDES THE LICENSE AND THE LIMITATION OF WARRANTY AND DISCLAIMER OF LIABILITY. IF YOU DO NOT AGREE TO THE TERMS OF THIS AGREEMENT, RETURN THE UNOPENED PRODUCT TO CABLETRON OR YOUR DEALER, IF ANY, WITHIN TEN (10) DAYS FOLLOWING THE DATE OF RECEIPT FOR A FULL REFUND.

IF YOU HAVE ANY QUESTIONS ABOUT THIS AGREEMENT, CONTACT CABLETRON SYSTEMS (603) 332-9400. Attn: Legal Department.

**1. LICENSE.** You have the right to use only the one (1) copy of the Program provided in this package subject to the terms and conditions of this License Agreement.

You may not copy, reproduce or transmit any part of the Program except as permitted by the Copyright Act of the United States or as authorized in writing by Cabletron.

**2. OTHER RESTRICTIONS.** You may not reverse engineer, decompile, or disassemble the Program.

**3. APPLICABLE LAW.** This License Agreement shall be interpreted and governed under the laws and in the state and federal courts of New Hampshire. You accept the personal jurisdiction and venue of the New Hampshire courts.

**4. EXPORT REQUIREMENTS.** You understand that Cabletron and its Affiliates are subject to regulation by agencies of the U.S. Government, including the U.S. Department of Commerce, which prohibit export or diversion of certain technical products to certain countries, unless a license to export the product is obtained from the U.S. Government or an exception from obtaining such license may be relied upon by the exporting party.

If the Program is exported from the United States pursuant to the License Exception CIV under the U.S. Export Administration Regulations, You agree that You are a civil end user of the Program and agree that You will use the Program for civil end uses only and not for military purposes.

If the Program is exported from the United States pursuant to the License Exception TSR under the U.S. Export Administration Regulations, in addition to the restriction on transfer set forth in Sections 1 or 2 of this Agreement, You agree not to (i) reexport or release the Program, the source code for the Program or technology to a national of a country in Country Groups D:1 or E:2 (Albania, Armenia, Azerbaijan, Belarus, Bulgaria, Cambodia, Cuba, Estonia, Georgia, Iraq, Kazakhstan, Kyrgyzstan, Laos, Latvia, Libya, Lithuania, Moldova, North Korea, the People's Republic of China, Romania, Russia, Rwanda, Tajikistan, Turkmenistan, Ukraine, Uzbekistan, Vietnam, or such other countries as may be designated by the United States Government), (ii) export to Country Groups D:1 or E:2 (as defined herein) the direct product of the Program or the technology, if such foreign produced direct product is subject to national security controls as identified on the U.S. Commerce Control List, or (iii) if the direct product of the technology is a complete plant or any major component of a plant, export to Country Groups D:1 or E:2 the direct product of the plant or a major component thereof, if such foreign produced direct product is subject to national security controls as identified on the U.S. Commerce Control List or is subject to State Department controls under the U.S. Munitions List.

**5. UNITED STATES GOVERNMENT RESTRICTED RIGHTS.** The enclosed Product (i) was developed solely at private expense; (ii) contains "restricted computer software" submitted with restricted rights in accordance with section 52.227-19 (a) through (d) of the Commercial Computer Software-Restricted Rights Clause and its successors, and (iii) in all respects is proprietary data belonging to Cabletron and/or its suppliers. For Department of Defense units, the Product is considered commercial computer software in accordance with DFARS section 227.7202-3 and its successors, and use, duplication, or disclosure by the Government is subject to restrictions set forth herein.

**6. EXCLUSION OF WARRANTY.** Except as may be specifically provided by Cabletron in writing, Cabletron makes no warranty, expressed or implied, concerning the Program (including its documentation and media).

CABLETRON DISCLAIMS ALL WARRANTIES, OTHER THAN THOSE SUPPLIED TO YOU BY CABLETRON IN WRITING, EITHER EXPRESS OR IMPLIED, INCLUDING BUT NOT LIMITED TO IMPLIED WARRANTIES OF MERCHANTABILITY AND FITNESS FOR A PARTICULAR PURPOSE, WITH RESPECT TO THE PROGRAM, THE ACCOMPANYING WRITTEN MATERIALS, AND ANY ACCOMPANYING HARDWARE.

**7. NO LIABILITY FOR CONSEQUENTIAL DAMAGES.** IN NO EVENT SHALL CABLETRON OR ITS SUPPLIERS BE LIABLE FOR ANY DAMAGES WHATSOEVER (INCLUDING, WITHOUT LIMITATION, DAMAGES FOR LOSS OF BUSINESS, PROFITS, BUSINESS INTERRUPTION, LOSS OF BUSINESS INFORMATION, SPECIAL, INCIDENTAL, CONSEQUENTIAL, OR RELIANCE DAMAGES, OR OTHER LOSS) ARISING OUT OF THE USE OR INABILITY TO USE THIS CABLETRON PRODUCT, EVEN IF CABLETRON HAS BEEN ADVISED OF THE POSSIBILITY OF SUCH DAMAGES. BECAUSE SOME STATES DO NOT ALLOW THE EXCLUSION OR LIMITATION OF LIABILITY FOR CONSEQUENTIAL OR INCIDENTAL DAMAGES, OR IN THE DURATION OR LIMITATION OF IMPLIED WARRANTIES IN SOME INSTANCES, THE ABOVE LIMITATION AND EXCLUSIONS MAY NOT APPLY TO YOU.

---

**CABLETRON SYSTEMS SALES AND SERVICE, INC.  
PROGRAM LICENSE AGREEMENT**

**IMPORTANT: THIS LICENSE APPLIES FOR USE OF PRODUCT IN THE UNITED STATES OF AMERICA AND BY UNITED STATES OF AMERICA GOVERNMENT END USERS.**

**BEFORE OPENING OR UTILIZING THE ENCLOSED PRODUCT, CAREFULLY READ THIS LICENSE AGREEMENT.**

This document is an agreement ("Agreement") between You, the end user, and Cabletron Systems Sales and Service, Inc. ("Cabletron") that sets forth your rights and obligations with respect to the Cabletron software program ("Program") in the package. The Program may be contained in firmware, chips or other media. UTILIZING THE ENCLOSED PRODUCT, YOU ARE AGREEING TO BECOME BOUND BY THE TERMS OF THIS AGREEMENT, WHICH INCLUDES THE LICENSE AND THE LIMITATION OF WARRANTY AND DISCLAIMER OF LIABILITY. IF YOU DO NOT AGREE TO THE TERMS OF THIS AGREEMENT, RETURN THE UNOPENED PRODUCT TO CABLETRON OR YOUR DEALER, IF ANY, WITHIN TEN (10) DAYS FOLLOWING THE DATE OF RECEIPT FOR A FULL REFUND.

IF YOU HAVE ANY QUESTIONS ABOUT THIS AGREEMENT, CONTACT CABLETRON SYSTEMS (603) 332-9400. Attn: Legal Department.

**1. LICENSE.** You have the right to use only the one (1) copy of the Program provided in this package subject to the terms and conditions of this License Agreement.

You may not copy, reproduce or transmit any part of the Program except as permitted by the Copyright Act of the United States or as authorized in writing by Cabletron.

**2. OTHER RESTRICTIONS.** You may not reverse engineer, decompile, or disassemble the Program.

**3. APPLICABLE LAW.** This License Agreement shall be interpreted and governed under the laws and in the state and federal courts of New Hampshire. You accept the personal jurisdiction and venue of the New Hampshire courts.

**4. EXPORT REQUIREMENTS.** You understand that Cabletron and its Affiliates are subject to regulation by agencies of the U.S. Government, including the U.S. Department of Commerce, which prohibit export or diversion of certain technical products to certain countries, unless a license to export the product is obtained from the U.S. Government or an exception from obtaining such license may be relied upon by the exporting party.

If the Program is exported from the United States pursuant to the License Exception CIV under the U.S. Export Administration Regulations, You agree that You are a civil end user of the Program and agree that You will use the Program for civil end uses only and not for military purposes.

If the Program is exported from the United States pursuant to the License Exception TSR under the U.S. Export Administration Regulations, in addition to the restriction on transfer set forth in Sections 1 or 2 of this Agreement, You agree not to (i) reexport or release the Program, the source code for the Program or technology to a national of a country in Country Groups D:1 or E:2 (Albania, Armenia, Azerbaijan, Belarus, Bulgaria, Cambodia, Cuba, Estonia, Georgia, Iraq, Kazakhstan, Kyrgyzstan, Laos, Latvia, Libya, Lithuania, Moldova, North Korea, the People's Republic of China, Romania, Russia, Rwanda, Tajikistan, Turkmenistan, Ukraine, Uzbekistan, Vietnam, or such other countries as may be designated by the United States Government), (ii) export to Country Groups D:1 or E:2 (as defined herein) the direct product of the Program or the technology, if such foreign produced direct product is subject to national security controls as identified on the U.S. Commerce Control List, or (iii) if the direct product of the technology is a complete plant or any major component of a plant, export to Country Groups D:1 or E:2 the direct product of the plant or a major component thereof, if such foreign produced direct product is subject to national security controls as identified on the U.S. Commerce Control List or is subject to State Department controls under the U.S. Munitions List.

**5. UNITED STATES GOVERNMENT RESTRICTED RIGHTS.** The enclosed Product (i) was developed solely at private expense; (ii) contains "restricted computer software" submitted with restricted rights in accordance with section 52.227-19 (a) through (d) of the Commercial Computer Software-Restricted Rights Clause and its successors, and (iii) in all respects is proprietary data belonging to Cabletron and/or its suppliers. For Department of Defense units, the Product is considered commercial computer software in accordance with DFARS section 227.7202-3 and its successors, and use, duplication, or disclosure by the Government is subject to restrictions set forth herein.

**6. EXCLUSION OF WARRANTY.** Except as may be specifically provided by Cabletron in writing, Cabletron makes no warranty, expressed or implied, concerning the Program (including its documentation and media).

CABLETRON DISCLAIMS ALL WARRANTIES, OTHER THAN THOSE SUPPLIED TO YOU BY CABLETRON IN WRITING, EITHER EXPRESS OR IMPLIED, INCLUDING BUT NOT LIMITED TO IMPLIED WARRANTIES OF MERCHANTABILITY AND FITNESS FOR A PARTICULAR PURPOSE, WITH RESPECT TO THE PROGRAM, THE ACCOMPANYING WRITTEN MATERIALS, AND ANY ACCOMPANYING HARDWARE.

**7. NO LIABILITY FOR CONSEQUENTIAL DAMAGES.** IN NO EVENT SHALL CABLETRON OR ITS SUPPLIERS BE LIABLE FOR ANY DAMAGES WHATSOEVER (INCLUDING, WITHOUT LIMITATION, DAMAGES FOR LOSS OF BUSINESS, PROFITS, BUSINESS INTERRUPTION, LOSS OF BUSINESS INFORMATION, SPECIAL, INCIDENTAL, CONSEQUENTIAL, OR RELIANCE DAMAGES, OR OTHER LOSS) ARISING OUT OF THE USE OR INABILITY TO USE THIS CABLETRON PRODUCT, EVEN IF CABLETRON HAS BEEN ADVISED OF THE POSSIBILITY OF SUCH DAMAGES. BECAUSE SOME STATES DO NOT ALLOW THE EXCLUSION OR LIMITATION OF LIABILITY FOR CONSEQUENTIAL OR INCIDENTAL DAMAGES, OR IN THE DURATION OR LIMITATION OF IMPLIED WARRANTIES IN SOME INSTANCES, THE ABOVE LIMITATION AND EXCLUSIONS MAY NOT APPLY TO YOU.



---

**CABLETRON SYSTEMS LIMITED  
PROGRAM LICENSE AGREEMENT**

**IMPORTANT: THIS LICENSE APPLIES FOR THE USE OF THE PRODUCT IN THE FOLLOWING GEOGRAPHICAL REGIONS:**

**EUROPE  
MIDDLE EAST  
AFRICA  
ASIA  
AUSTRALIA  
PACIFIC RIM**

**BEFORE OPENING OR UTILIZING THE ENCLOSED PRODUCT,  
CAREFULLY READ THIS LICENSE AGREEMENT.**

This document is an agreement (“Agreement”) between You, the end user, and Cabletron Systems Limited (“Cabletron”) that sets forth your rights and obligations with respect to the Cabletron software program (“Program”) in the package. The Program may be contained in firmware, chips or other media. UTILIZING THE ENCLOSED PRODUCT, YOU ARE AGREEING TO BECOME BOUND BY THE TERMS OF THIS AGREEMENT, WHICH INCLUDES THE LICENSE AND THE LIMITATION OF WARRANTY AND DISCLAIMER OF LIABILITY. IF YOU DO NOT AGREE TO THE TERMS OF THIS AGREEMENT, RETURN THE UNOPENED PRODUCT TO CABLETRON OR YOUR DEALER, IF ANY, WITHIN TEN (10) DAYS FOLLOWING THE DATE OF RECEIPT FOR A FULL REFUND.

IF YOU HAVE ANY QUESTIONS ABOUT THIS AGREEMENT, CONTACT CABLETRON SYSTEMS (603) 332-9400. Attn: Legal Department.

**1. LICENSE.** You have the right to use only the one (1) copy of the Program provided in this package subject to the terms and conditions of this License Agreement.

You may not copy, reproduce or transmit any part of the Program except as permitted by the Copyright Act of the United States or as authorized in writing by Cabletron.

**2. OTHER RESTRICTIONS.** You may not reverse engineer, decompile, or disassemble the Program.

**3. APPLICABLE LAW.** This License Agreement shall be governed in accordance with English law. The English courts shall have exclusive jurisdiction in the event of any disputes.

**4. EXPORT REQUIREMENTS.** You understand that Cabletron and its Affiliates are subject to regulation by agencies of the U.S. Government, including the U.S. Department of Commerce, which prohibit export or diversion of certain technical products to certain countries, unless a license to export the product is obtained from the U.S. Government or an exception from obtaining such license may be relied upon by the exporting party.

If the Program is exported from the United States pursuant to the License Exception CIV under the U.S. Export Administration Regulations, You agree that You are a civil end user of the Program and agree that You will use the Program for civil end uses only and not for military purposes.

If the Program is exported from the United States pursuant to the License Exception TSR under the U.S. Export Administration Regulations, in addition to the restriction on transfer set forth in Sections 1 or 2 of this Agreement, You agree not to (i) reexport or release the Program, the source code for the Program or technology to a national of a country in Country Groups D:1 or E:2 (Albania, Armenia, Azerbaijan, Belarus, Bulgaria, Cambodia, Cuba, Estonia, Georgia, Iraq, Kazakhstan, Kyrgyzstan, Laos, Latvia, Libya, Lithuania, Moldova, North Korea, the People's Republic of China, Romania, Russia, Rwanda, Tajikistan, Turkmenistan, Ukraine, Uzbekistan, Vietnam, or such other countries as may be designated by the United States Government), (ii) export to Country Groups D:1 or E:2 (as defined herein) the direct product of the Program or the technology, if such foreign produced direct product is subject to national security controls as identified on the U.S. Commerce Control List, or (iii) if the direct product of the technology is a complete plant or any major component of a plant, export to Country Groups D:1 or E:2 the direct product of the plant or a major component thereof, if such foreign produced direct product is subject to national security controls as identified on the U.S. Commerce Control List or is subject to State Department controls under the U.S. Munitions List.

**5. UNITED STATES GOVERNMENT RESTRICTED RIGHTS.** The enclosed Product (i) was developed solely at private expense; (ii) contains "restricted computer software" submitted with restricted rights in accordance with section 52.227-19 (a) through (d) of the Commercial Computer Software-Restricted Rights Clause and its successors, and (iii) in all respects is proprietary data belonging to Cabletron and/or its suppliers. For Department of Defense units, the Product is considered commercial computer software in accordance with DFARS section 227.7202-3 and its successors, and use, duplication, or disclosure by the Government is subject to restrictions set forth herein.

**6. EXCLUSION OF WARRANTY.** Except as may be specifically provided by Cabletron in writing, Cabletron makes no warranty, expressed or implied, concerning the Program (including its documentation and media).

CABLETRON DISCLAIMS ALL WARRANTIES, OTHER THAN THOSE SUPPLIED TO YOU BY CABLETRON IN WRITING, EITHER EXPRESS OR IMPLIED, INCLUDING BUT NOT LIMITED TO IMPLIED WARRANTIES OF MERCHANTABILITY AND FITNESS FOR A PARTICULAR PURPOSE, WITH RESPECT TO THE PROGRAM, THE ACCOMPANYING WRITTEN MATERIALS, AND ANY ACCOMPANYING HARDWARE.

**7. NO LIABILITY FOR CONSEQUENTIAL DAMAGES.** IN NO EVENT SHALL CABLETRON OR ITS SUPPLIERS BE LIABLE FOR ANY DAMAGES WHATSOEVER (INCLUDING, WITHOUT LIMITATION, DAMAGES FOR LOSS OF BUSINESS, PROFITS, BUSINESS INTERRUPTION, LOSS OF BUSINESS INFORMATION, SPECIAL, INCIDENTAL, CONSEQUENTIAL, OR RELIANCE DAMAGES, OR OTHER LOSS) ARISING OUT OF THE USE OR INABILITY TO USE THIS CABLETRON PRODUCT, EVEN IF CABLETRON HAS BEEN ADVISED OF THE POSSIBILITY OF SUCH DAMAGES. BECAUSE SOME STATES DO NOT ALLOW THE EXCLUSION OR LIMITATION OF LIABILITY FOR CONSEQUENTIAL OR INCIDENTAL DAMAGES, OR IN THE DURATION OR LIMITATION OF IMPLIED WARRANTIES IN SOME INSTANCES, THE ABOVE LIMITATION AND EXCLUSIONS MAY NOT APPLY TO YOU.

**DECLARATION OF CONFORMITY**

Application of Council Directive(s): 89/336/EEC  
73/23/EEC

Manufacturer's Name: Cabletron Systems, Inc.

Manufacturer's Address: 35 Industrial Way  
PO Box 5005  
Rochester, NH 03867

European Representative Name: Mr. J. Solari

European Representative Address: Cabletron Systems Limited  
Nexus House, Newbury Business  
Park  
London Road, Newbury  
Berkshire RG13 2PZ, England

Conformance to Directive(s)/Product Standards: **EC Directive 89/336/EEC**  
**EC Directive 73/23/EEC**  
**EN 55022**  
**EN 50082-1**  
**EN 60950**

Equipment Type/Environment: Networking Equipment, for use in a  
Commercial or Light Industrial  
Environment.

We the undersigned, hereby declare, under our sole responsibility, that the equipment packaged with this notice conforms to the above directives.

Manufacturer

Mr. Ronald Fotino

Full Name

Compliance Engineering Manager

Title

Rochester, NH, USA

Location

Legal Representative in Europe

Mr. J. Solari

Full Name

Managing Director - E.M.E.A.

Title

Newbury, Berkshire, England

Location



---

## Table Of Contents

---

Preface .....	xv
Purpose .....	xv
Audience .....	xv
Conventions .....	xv
Message Formats .....	xv
Keyboard Entries .....	xv
Other Conventions .....	xvi
Organization .....	xvi
1. Product Overview .....	1
Description .....	1
Features .....	2
Front Panel .....	4
Optional Modules .....	5
Rear Panel .....	7
Feature Summaries .....	7
Dual-Speed Architecture .....	7
Software Download .....	7
Non-volatile Parameter Storage .....	8
Configuration and Management Interfaces .....	8
RMON .....	9
Auto-Sensing and Auto-Negotiation .....	9
BootP .....	10
LEDs .....	10
Full Duplex Mode .....	10
Application Example .....	10
2. Installation .....	13
Inspecting Your Shipment .....	13
Site Requirements .....	13
Mounting the Hub or Stack on a Table or Shelf .....	14
Mounting the Hub in a Rack .....	15
Connecting Hubs to the Stack's Backplane .....	16
Installing an Optional Module into the Hub .....	17
Using a Switch/Media Module .....	18
Connecting a Terminal to the Console Port .....	19
Console Port (Out-of-Band) Connections .....	19
Remote Management via the Console Port .....	20
In-Band Connections .....	20
Agent Module .....	21
Powering the Hub .....	22
Network Cable Requirements .....	23
Copper .....	23
Fiber .....	23
10Base-T/100Base-TX Ports .....	24
100Base-FX Fiber Ports .....	25

<b>3. ELH100-12/24TX User Interface</b> . . . . .	27
Overview . . . . .	27
User Access . . . . .	28
Factory Defaults . . . . .	28
Menu Hierarchy . . . . .	29
Main Menu . . . . .	30
System Information Menu . . . . .	31
Reset . . . . .	32
Exit . . . . .	32
System Configuration Menu . . . . .	33
SNMP Configuration Menu . . . . .	35
SNMP Communities . . . . .	36
SNMP Trap Destinations . . . . .	37
Hub Configuration Menus . . . . .	38
Port Configuration Menu . . . . .	41
Port Administrative Status Control Menu . . . . .	41
Module Port Configuration Menu . . . . .	42
Backup Port Control Menu . . . . .	43
TFTP Download Menu . . . . .	44
XMODEM Download Menu . . . . .	45
User Password Menu . . . . .	46
Console Configuration Menu . . . . .	47
Hub Statistics Menu . . . . .	48
Port Statistics Menu . . . . .	50
<b>4. Configuring &amp; Monitoring the Hub</b> . . . . .	53
Common Tasks . . . . .	53
Setting Password Protection . . . . .	53
Assigning an IP Address . . . . .	54
Checking Network Configuration Status . . . . .	54
Connecting via Telnet . . . . .	55
Setting SNMP Management Access . . . . .	55
Viewing Hub Statistics . . . . .	56
Downloading a Software Upgrade . . . . .	56
Downloading Via the Serial Port . . . . .	56
Downloading Via TFTP . . . . .	57
Configuring Port Operation . . . . .	58
Spanning Tree . . . . .	58
Setting a Default Gateway . . . . .	58
Configuring BootP . . . . .	59
<b>5. Web-Based Management</b> . . . . .	61
Navigating the Web Browser Interface . . . . .	61
Main Menu . . . . .	62
System Information . . . . .	63
Stack Browser . . . . .	64
Front Panel . . . . .	65
Agent Configuration . . . . .	66
Hub Configuration . . . . .	67

Hub Backplane . . . . .	68
Port Configuration . . . . .	69
Port Backup . . . . .	70
Switch Module Statistics . . . . .	71
MIB Browser . . . . .	72
RMON Browser . . . . .	73
Ethernet Statistics . . . . .	74
Packets Pie Chart . . . . .	76
Error Packets Ratio . . . . .	77
History Control Entry . . . . .	78
History Data Entry . . . . .	79
Rate Bar Chart . . . . .	81
Utilization . . . . .	82
Alarm . . . . .	83
Event Table . . . . .	85
Log Table . . . . .	86
<b>6. SNMP Management . . . . .</b>	<b>87</b>
The SNMP Protocol . . . . .	87
MIB Objects . . . . .	88
RFC 1213 (MIB-II) . . . . .	88
RFC 2108 (Multi-segment Repeater) . . . . .	89
RFC 1643 (Ethernet-like) . . . . .	89
RFC 1757 (RMON MIB) . . . . .	89
Cabletron Proprietary MIB Extensions . . . . .	89
Compiling MIB Extensions: Cabletron Website . . . . .	90
<b>APPENDIX A. Technical Specifications . . . . .</b>	<b>91</b>
General . . . . .	91
Standards Compliance . . . . .	91
Certification . . . . .	91
Data Rate . . . . .	91
Environmental Specifications . . . . .	91
Electrical Specifications . . . . .	92
Physical . . . . .	92
Port Specifications . . . . .	93
Console Port . . . . .	93
10Base-T and 100Base-TX Ports . . . . .	93
MDI/MDI-X Crossover Cable Wiring . . . . .	94
Power Cord Set Requirements . . . . .	94
General Requirements . . . . .	94
Country-Specific Requirements . . . . .	95
<b>APPENDIX B. Acronyms &amp; Abbreviations . . . . .</b>	<b>97</b>

**INDEX**





---

# PREFACE

---

## Purpose

This guide provides information about the features and applications of the Cabletron ELH100-12/24TX dual-speed hub as well as instructions for configuring and monitoring the hub.

## Audience

This guide is intended for Ethernet local area network (LAN) administrators and Management Information Systems (MIS) personnel with the following background:

- Working knowledge of Ethernet LANs
- Familiarity with Transmission Control Protocol/Internet Protocol (TCP/IP) and Simple Network Management Protocol (SNMP)

## Conventions

This section describes the conventions used in this guide.

### Message Formats

Two types of messages, identified by icons, appear in the text:



**A note informs you of special circumstances.**



**A caution indicates the possibility of equipment damage.**

### Keyboard Entries

This guide uses the following conventions for keyboard entries:

- When you read “enter,” type the text and press the [Enter] key.
- Example: Enter the Gateway IP address and press the [Enter] key.
- When you read “select,” highlight the menu item and press the [Enter] key.

---

## Other Conventions

This guide uses the following typographical conventions:

- Initial Caps      Menu titles and console menu selections.
- [Enter]            Used to designate the Enter or Return key.
- ALL CAPS          Used to designate fields within the console menus (Example: CONNECTION).
- `courier font`    Screen messages and user prompts.
- Selection          Describes a user-configurable user interface item.
- Field                Describes a read-only information item.

## Organization

**Chapter 1. Product Overview:** Describes the features of the hub, front and rear panel components and application examples.

**Chapter 2. Installation:** Describes the content of your hub shipment, lists site requirements, and provides mounting instructions. Instructions for making connections and powering up the hub are provided as well.

**Chapter 3. ELH100-12/24TX User Interface:** Describes the user interface console menus and lists the factory defaults for system settings. Each of the console menus are presented along with a description of the selections/fields available within each menu.

**Chapter 4. Configuring and Monitoring the Hub:** Describes common tasks and associated steps required to configure the hub, and covers common hub and network considerations required to ensure system integrity.

**Chapter 5. Web-Based Management:** Describes the tasks and associated steps required to configure the hub via the embedded Web agent. It also covers information on using the RMON Browser.

**Chapter 6. SNMP Management:** Describes how the Simple Network Management Protocol (SNMP) communication protocol is used to manage the hub, and provides a description of industry standard and proprietary Managed Information Bases (MIBs) supported by the hub.

**Appendix A. Technical Specifications:** Provides a list of standards compliance and certifications as well as physical and operational specifications.

**Appendix B. Acronyms and Abbreviations:** Provides definitions for a list of common acronyms and abbreviations used within the user guide and the networking industry.

---

# 1. PRODUCT OVERVIEW

---

## Description

This installation and user guide describes Cabletron's ELH100-12/24TX Fast Ethernet hubs. These hubs provide the easiest method of upgrading your network to Fast Ethernet. There's no need to replace your existing network infrastructure. Just add Cabletron's hub to your network and attach any 10 or 100 Mbps device to any port on the hub. These hubs provide both a 10 Mbps segment needed for common file transfers, as well as a 100 Mbps segment for relieving serious network congestion, running multimedia applications, or satisfying power users.

These hubs include a wide range of configuration options. They can be stacked together (up to 6 high) to form a dual-speed network of up to 144 ports. With a Class II rating, they can also be easily cascaded to additional 10 or 100 Mbps hubs. With an optional switch/media module, you can link the hub's 10 Mbps and 100 Mbps segments together to form a bridged network, allowing traffic to pass between the segments when required.

Optional switch/media modules are also provided for 10Base-T/100Base-TX and 100Base-FX media types. The fiber modules allow you to connect the stack to remote locations up to 1.24 miles away (2 kilometers). Each of these switch/media modules provide a switched connection to the stack, breaking the two-hop count for Fast Ethernet by placing all the devices attached to the module in a separate collision domain. The modules operate at full wire speed with full address and frame filtering. They automatically learn node addresses from the network and store them in a Media Access Control (MAC) address forwarding table. Incoming packets are then forwarded on to the stack or filtered based on the addresses in the packet.

The optional RMON/SNMP/Web Agent Module provides a broad range of management options. It includes a standards-compliant Simple Network Management Protocol (SNMP) agent. The SNMP agent allows network management station applications to collect and present status and performance information about the stack, as well as providing the ability to configure and control functions on the stack. The module also supports Remote Monitoring (RMON) for Statistics, History, Alarm and Event groups (Groups 1-3, 9).

Network management can be performed in-band using TCP/IP, Telnet, or via a SLIP connection to the serial console port on the Agent Module. This module also includes a built-in Web agent that provides management access via common http browsers such as Netscape Navigator and Microsoft's Internet Explorer. In addition, the console port allows out-of-band management using a PC, terminal, or modem connection.

---

The ELH100-12/24TX hub is desktop or rack-mountable. LEDs on the front panel provide information about the operating status of the hub. The back panel contains the power connector, redundant power connector, and stack connectors. The side panel includes two fans that maintain ventilation and cooling for internal hub components.

This chapter provides the following information:

- Product Description
- Features
- Front and Rear Panel Component Descriptions
- Feature Summaries
- Application Example

## Features

- Ports:
  - 12/24 dual-speed 10Base-T/100Base-TX ports using RJ-45 connectors (MDI-X)  
Note: Port 12/24 includes a toggle switch for MDI-X or MDI connection
  - 2 SCSI connectors for stacking hubs
  - 1 redundant power unit socket
- Optional Switch/Media Modules:
  - ELH-ULSW-TX: 10Base-T/100Base-TX Module\* provides 1 RJ-45 port for a bridged connection to the stack, as well as bridging between the 10 and 100 Mbps stack segments  
\* Includes MDI-X or MDI connection (only 1 connection active at a time)
  - ELH-ULSW-F2: 100Base-FX Module provides 1 SC multimode fiber optic port for a bridged connection to the stack, as well as bridging between the 10 and 100 Mbps stack segments
- Optional RMON/SNMP/Web Agent Module:
  - ELH100-SNMP: Agent Module provides SNMP, RMON, and Web management support for the stack. Only two agent modules are allowed in a stack: one active and one in standby mode.
- Hub Architecture:
  - 2 segment repeaters for 10 and 100 Mbps
  - 3 or 6 Quad Controllers with 4 10/100 ports, 2 10/100 segment repeaters, cascaded backplanes, serial management interface
  - IEEE 802.3u auto-sensing for 10/100 Mbps speed operation on all RJ-45 ports (not required on attached device)
  - Up to 6 hub units can be stacked together, supporting up to 144 connections

- 
- Switch Architecture (for optional switch/media modules):
    - Bridges 10 and 100 Mbps repeater buses for the stack
    - 200 Mbps throughput
    - 2 MB packet buffering
    - Store-and-forward switching
    - Module: 4096 address forwarding table per segment
    - Forwarding: 14,880 packets-per-second (64 byte packets) @10 Mbps; 148,800 pps @100 Mbps
    - Filtering: 14,880 packets-per-second (64 byte packets) @10 Mbps; 148,800 pps @100 Mbps
  - Network Management:
    - SNMP compliant agent: MIB II (RFC 1213); Multi-segment Repeater MIB (RFC 2108), Ethernet-like MIB (RFC1643); RMON - Statistics, History, Alarm and Event groups per segment (RFC 1757); private MIB extensions
    - Access via in-band, Internet browser, or Telnet
    - Console port (RS-232, male DB-9 connector, null modem) supports access via direct, modem, or SLIP connection
    - BootP for IP address configuration
  - Reliability:
    - Automatic partition and reconnection
    - Automatic polarity detection (and inversion if needed)
    - Automatic cascade bypass if a hub in the stack is powered off
    - Agent Module supports power-on self test, backup agent module, port link backup for up to 15 pairs, and intrusion detection
  - Software:
    - Extensive diagnostics for product testing and troubleshooting
    - Firmware upgrades using the console port or in-band with TFTP
  - LED Indicators:
    - System: Power, Switch
    - 10 and 100 Mbps segments: Activity, Collision
    - 10Base-T/100Base-TX Ethernet hub ports: link/partition/speed
    - Switch/Media modules: Collision, Activity, Full/Half duplex, Link
    - Agent Module: Active

# Front Panel

Figure 1-1 shows the front panel of the Cabletron ELH100-24TX. Table 1-1 defines the ELH100-12/24TX front panel components.

**Figure 1-1. ELH100-24TX Front Panel**

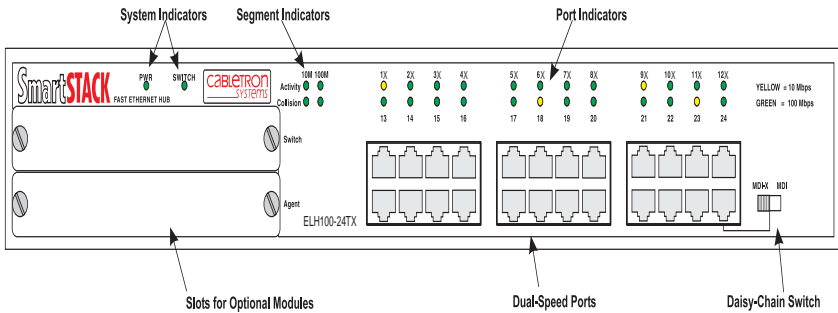

**Table 1-1. Front Panel Components**

Name	Function
PWR LED	Lights steady green to indicate power is supplied to the hub. Off indicates no power is supplied to the hub.
SWITCH LED	Lights steady green to indicate that the Switch/Media Module is active. Flashing indicates that another module in the stack is active. (If the active module fails, you must remove it from the stack to initialize a backup switch/media module located in another hub in the stack.)
Segment LEDs (10M, 100M)	Activity: Flashing indicates traffic on the segment. Collision: Flashing indicates that two or more devices attempted to transmit data at the same time. (This is a normal situation under Ethernet CSMA/CD.)
Port LEDs	On indicates link; off indicates no link; and flashing indicates that the port has been partitioned. Yellow indicates a 10 Mbps connection; green indicates a 100 Mbps connection.
10Base-T/100Base-TX RJ-45 ports	Copper ports using RJ-45 port connectors. These ports are wired MDI-X, except for the last port which includes a selection switch for MDI-X or MDI connection.

## Optional Modules

Figure 1-2 shows the optional modules available for the Cabletron ELH100-12/24TX. Table 1-2 defines the optional module components.

**Figure 1-2. Optional Modules**

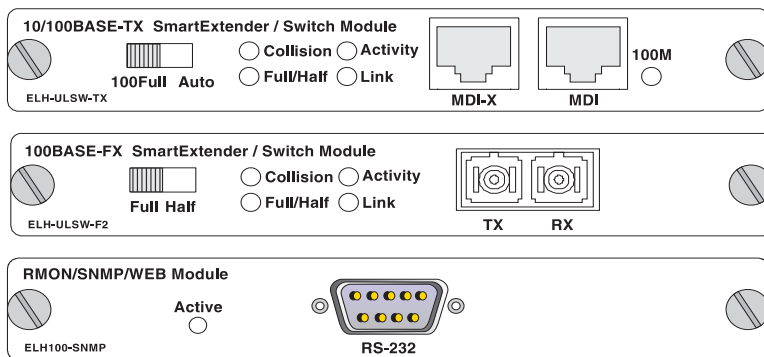

**Table 1-2. Optional Module Components**

Module	Components
10Base-T/100Base-TX	<p>Ports: Copper ports using RJ-45 connectors. Use either the MDI-X or MDI connector when attaching a device to this module. (See 10Base-T/100Base-TX Ports on page 24 for a detailed description of these ports.)</p> <p>Mode switch: If the attached device must operate at 100 Mbps, full duplex, then set this switch to 100Full; otherwise, set it to Auto.</p> <p>Port LEDs: See Table 1-3 for details.</p>
100Base-FX	<p>Ports: Fiber ports using SC connectors for uplink. (See 100Base-FX Fiber Ports on page 25 for a detailed description of these ports.)</p> <p>Mode switch: If the attached device must operate at full duplex, set this switch to Full; otherwise, set it to Half.</p> <p>Port LEDs: See Table 1-3 for details.</p>
Agent	<p>Console port: Male DB-9 connector configured as a null modem connection for serial out-of-band management using the console menus, or for in-band management when used with SLIP protocol.</p> <p>Active LED: On when the Agent Module is active; off when the module is in standby mode, and flashing if the module failed the power-on self-test.</p> <p>Only two agent modules are allowed in a stack: one active and one in standby mode.</p>

Figure 1-3 shows the Collision, Activity, Full/Half duplex, and Link LEDs for the switch/media modules. These LEDs are positioned to the left of the ports. In addition, the 10Base-T/100Base-TX module includes a 100M LED to right of the ports to indicate speed (where On indicates that the port is operating at 100 Mbps, and Off indicates 10 Mbps).

**Figure 1-3. Port LEDs on the Switch/Media Modules**

- Collision    Activity  
 Full/Half    Link

Table 1-3 defines the performance of the port LEDs on the optional modules.

**Table 1-3. Port LEDs for Modules Defined**

Name	Function
Collision	Flashing: Two or more devices attempted to transmit data at the same time. (Normal situation under Ethernet CSMA/CD.)
Activity	Flashing: Indicates the presence of transmit and/or receive activity. Off: Indicates the absence of transmit or receive activity.
Full/Half	On: Indicates the port is in full duplex mode. Off: Indicates the port is in half duplex mode.
Link	On: Indicates a valid connection (link) on the associated port. Off: Indicates no link on the associated port.
100M*	On: Indicates that the port is operating at 100 Mbps. Off: Indicates that the port is operating at 10 Mbps.

\* This LED only appears on the 10Base-T/100Base-TX module.



**The Switch/Media modules do not support Spanning Tree, which is intended to prevent network loops from forming. There is no loop detection. The user is cautioned to understand and avoid configurations that can create a loop.**



---

## Rear Panel

Figure 1-4 shows the ELH100-12/24TX rear panel and Table 1-4 defines the rear panel components.

**Figure 1-4. ELH100-12/24TX Rear Panel**

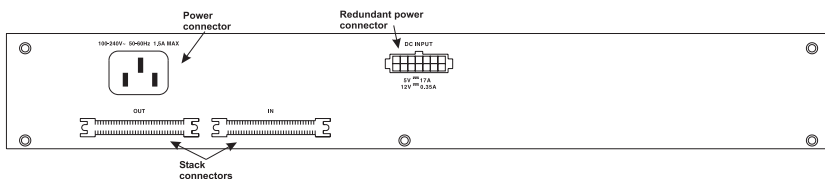

**Table 1-4. Rear Panel Components**

Name	Function
Power Connector	Provides AC power to the switch.
Redundant Power Connector	This connector is provided for a redundant power unit (RPU) which can supply power to the hub if its primary power supply fails. (Refer to the manual provided with the RPU for further details.)
Stack Connectors	Allows you to stack up to 6 units to form a dual-speed network of up to 144 ports.

## Feature Summaries

The following summaries describe ELH100-12/24TX features in areas such as standards compliance, functionality, performance, and options.

### Dual-Speed Architecture

The ELH100-12/24TX hub provides both 10 and 100 Mbps repeater buses. The speed of the device connected to each port is automatically detected by the hub, and the port attached to the appropriate bus. Up to 6 hubs can be stacked together to form a dual-speed network. An optional switch/media module can be added to any hub in the stack to bridge traffic between the 10 Mbps and 100 Mbps repeater buses as required.

### Software Download

The ELH100-12/24TX hubs support the industry-standard Trivial File Transfer Protocol (TFTP) for downloading agent software. All hub software is stored in a 2 MB flash ROM. The download feature allows you to easily install software upgrades to the Agent Module. Software can alternatively be downloaded via the serial console port using the XMODEM protocol. You can download to permanent flash ROM, or you can download to temporary storage in RAM for test purposes.

---

A TFTP or XMODEM software download is invoked via the console menus. A TFTP download can also be invoked via SNMP or Web-based manager.

## Non-volatile Parameter Storage

All important operating parameters, such as management data and port configurations, are stored in non-volatile Flash memory. These values are retained when the hub experiences power interruptions or is powered down for normal maintenance.

## Configuration and Management Interfaces

The ELH100-12/24TX hub, or attached stack, can be managed using any of the following methods:

- Serial console, out-of-band or in-band

An RS-232 connection, using a DB-9 connector, is included on the Agent Module for system management. Serial console management can be performed out-of-band using a terminal or computer running communications software. You can connect directly to the RS-232 port on the Agent Module, or make a connection via a modem. See Chapter 3, ELH100-12/24TX User Interface, for information on managing the ELH100-12/24TX hub (or stack) via the serial console.

You can also make an in-band connection to the RS-232 port on the Agent Module with SLIP protocol. Using this kind of connection, you can manage the system via any of the methods listed below.

- Telnet, in-band (over Ethernet)

The hub supports management through a Telnet connection using the TCP/IP protocols. Telnet is performed using a terminal or computer running communications software. See Chapter 3, ELH100-12/24TX User Interface, for information on managing the system via Telnet. Global user name and password protection for changing the operating parameters of the hub is provided.

- Web-based network manager, in-band

The system can be managed over HTTP protocol with a Web browser (Internet Explorer 3.0 or above, or Netscape Navigator 3.0 or above). Standard agent MIBs embedded in the hub provide basic SNMP management through an embedded graphic interface.

- SNMP-based network manager, in-band

The system can also be managed using SNMP, the most common protocol used today for network management. Standard agent MIBs embedded in the hub provide basic SNMP management through industry-standard SNMP applications.

Management security protection is provided based on SNMP community names. See Chapter 6, SNMP Management, for more information.

---

## RMON

RMON (Remote Monitoring) is a facility used to manage networks remotely while providing multi-vendor interoperability between monitoring devices and management stations. RMON is defined by an SNMP MIB. This MIB is divided into nine different groups, each gathering specific statistical information or performing a specific function. RMON-capable devices gather network traffic data and then store them locally until downloaded to an SNMP management station.

The ELH100-12/24TX supports four of the nine groups of RMON defined for Ethernet networks on a per segment basis. Specifically, these are:

- **Statistics:** a function that maintains counts of network traffic statistics such as number of packets, broadcasts, collisions, errors, and distribution of packet sizes.
- **History:** a function that collects historical statistics based on user-defined sampling intervals. The statistical information collected is the same as the Statistics group, except on a time stamped basis.
- **Alarm:** a function that allows managers to set alarm thresholds based on traffic statistics. Alarms trigger other actions through the Event group.
- **Event:** a function that operates with the Alarm group to define an action that will be taken when an alarm condition occurs. The event may write a log entry and/or send a trap message.

Because the Agent Module must be attached to either the 10 or 100 Mbps stack segment, RMON can only be activated for one segment at a time. You must therefore use an out-of-band connection to the Agent Module to select the segment to activate for RMON. However, note that RMON statistics and other information can only be viewed using a connection to the on-board web agent or via other compatible SNMP management applications.

## Auto-Sensing and Auto-Negotiation

Auto-sensing is a process that permits the hub to automatically select the operational speed of its ports. When an RJ-45 port on the base unit is connected, the hub detects and configures the port to the speed of the network the port is connected to, either 10 Mbps or 100 Mbps. Auto-sensing is configurable in the Port Configuration Menu of the console menu or via SNMP.

The 10Base-T/100Base-TX optional modules support auto-negotiation. The port automatically negotiates the best connection possible with the attached device. However, if the attached device must operate at full duplex, then it must also support auto-negotiation. Otherwise, you can set the mode manually using the mode selection switch on the module, or via the management agent.

The 100Base-FX module does not support auto-negotiation. You need to configure the duplex setting via the front panel switch.

---

## BootP

The Bootstrap Protocol (BootP) provides for the capability of passing configuration information to hosts on a TCP/IP network. Using this process, network devices do not need to be configured before they can communicate using the TCP/IP protocol suite. The ELH100-12/24TX uses BootP to automatically configure IP address information without requiring access to the console menus. BootP operation is configurable using the System Configuration Menu of the console menus, the on-board Web agent, or via SNMP.

## LEDs

The port LEDs on the hub unit provide a quick and accurate display of the integrity of hub connections, indicating link and partition for each of the ports. The port LEDs on the optional switch/media modules indicate Link, Activity, Collision, Full/Half duplex mode, and speed (100M) for each of the ports.



**The 100M LED appears only on the 10Base-T/  
100Base-TX module.**

## Full Duplex Mode

Full duplex mode is supported on the optional switch/media modules. This mode of operation can double the throughput of port connections, by disabling the collision detection portion of the Ethernet Carrier Sense Multiple Access with Collision Detection (CSMA/CD) protocol, allowing for two-way traffic. Full duplex is configurable using the Duplex parameter in the Switch/Media Menu of the console menus or via SNMP.

## Application Example

The exploding popularity of the Internet and of corporate intranets, as well as new, high-bandwidth desktop applications, are driving the demand for Fast Ethernet. The need to gradually phase in Fast Ethernet networks, without abandoning existing 10 Mbps network segments, is driving the need for economical dual-speed network solutions.

The ELH100-12/24TX hubs are ideal for gradually building up the network infrastructure needed to meet the demands of today's data intensive applications, while retaining the use of legacy network equipment. The hubs' low cost, high port count, and stacking capability make them attractive and affordable for dedicated 10/100 Mbps connections to the desktop. In addition, extensive features, including redundant links, port security, and micro-segmentation of bus connections, provide the management needed for the workgroup and local backbone.

Using the ELH100-12/24TX hub in an application example for client/server networks, users can be connected directly to the local network, regardless of whether they are operated at either 10 or 100 Mbps. Up to 144 connections can be supported by stacking up to 6 hubs. Being a Class II hub, additional 10Mbps or 100 Mbps hubs can be attached to the stack. The optional modules provide full duplex switched connections that can improve workstation performance in a client/server environment, or be used to aggregate traffic on the stack to the local backbone.

**Figure 1-5. Client/Server Network Application**

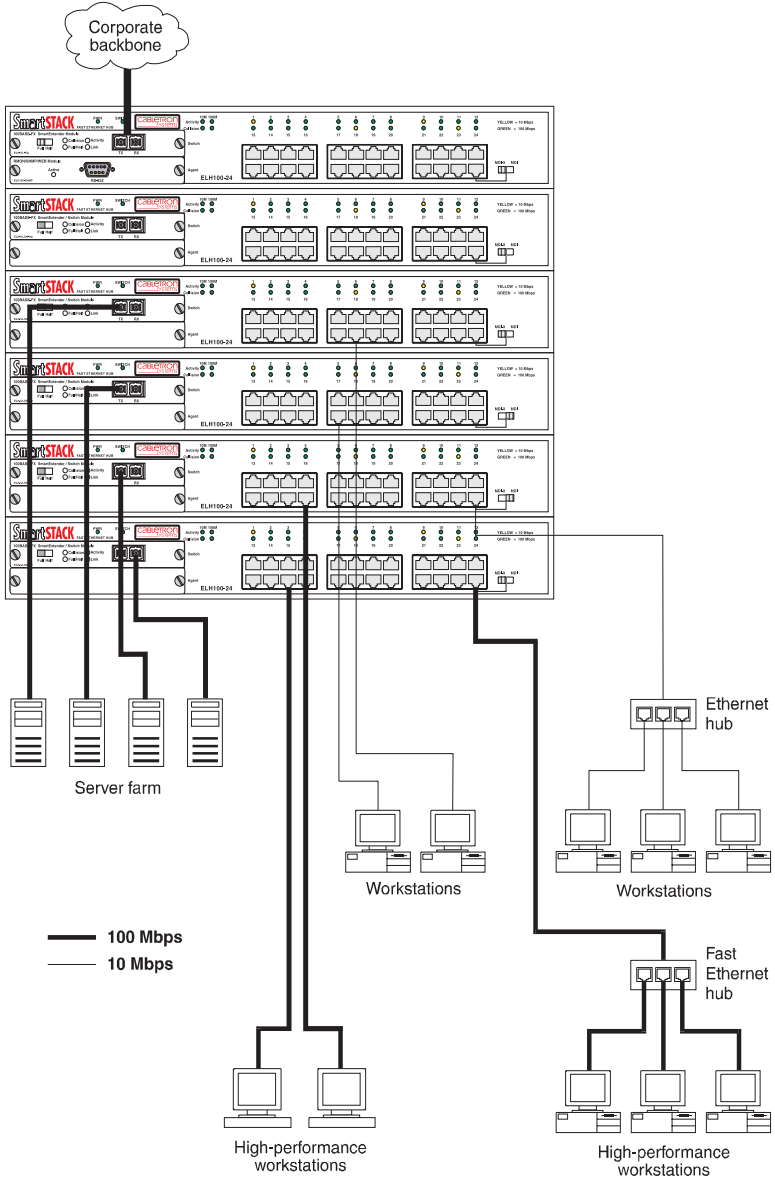



---

## 2. INSTALLATION

---

### Inspecting Your Shipment

When you receive the shipment of your hub, check the package contents and make sure you have the following items:

- ELH100-12/24TX dual speed Ethernet hub
- Mounting ears and mounting screws
- Four rubber feet
- Stack cable
- Power cord
- This document

### Site Requirements

Before you install the hub, make sure the site meets the following requirements:

- **Mounting**  
Provide a flat table, shelf surface, or an optional 19 in. (48.3 cm) equipment rack.  
Use an EIA standard equipment rack that is grounded and physically secure.
- **Power source**  
Provide a power source within six feet (1.8 m) of the installation location. This source must provide 100 VAC to 240 VAC, and 50 Hz to 60 Hz power, with a 50 VA minimum. Power specifications for the hub are shown in Appendix A, "Technical Specifications."



**Primary voltage selection within the above ranges is automatic and requires no user action.**

- **Environmental**  
Install the ELH100-12/24TX hub in a dry area, with adequate air circulation. Avoid placing the hub in direct sunlight or near other heat sources, such as hot-air vents. For temperature and humidity specifications, see Appendix A, "Technical Specifications."
- **Ventilation**  
Do not restrict airflow by covering or obstructing air inlets on the side of the hub.

---

## Mounting the Hub or Stack on a Table or Shelf

You can mount a standalone hub (or a stack of up to six hubs) on a table or shelf. Locate the hub (stack) in a position that allows access to the front panel RJ-45 ports, visibility of the port LEDs, and access to the power cord. Make sure that the mounting surface can safely support the hub (stack) and that there is adequate space around the hub (stack) for ventilation and cooling.

1. The hub ships with four (4) rubber feet. Stick the self-adhesive rubber foot pads on each of the four concave spaces located on the bottom of the hub. The rubber foot pads cushion the hub against shock/vibrations and provide space between each hub for ventilation.
2. If you want to stack hubs, repeat step 1 for each hub to be stacked. Place the first hub on a firm flat surface where you want to install the stack. Stack the other hubs on top of this unit.
3. Refer to "Connecting Hubs to the Stack's Backplane" on page 16.



---

## Mounting the Hub in a Rack

The hub ships with two (2) multi-position mounting ears and four (4) mounting screws.



**The mounting screws are used to attach the mounting ears to the hub. Once the ears are attached to the hub, you will need to provide appropriate screws to mount the hub in a rack.**

Figure 2-1 shows the orientation of the mounting ears for attaching the ears to the hub for a rack mount application. Mount the hub with the front panel facing forward. Do the following:

1. Mount one of the ears to the hub using two (2) of the supplied screws. Repeat this step for the other side of the hub.
2. Slide the hub into the rack and align the holes in the rack mounting ears with the holes in the rack rails.
3. Insert and tighten appropriate rack-mounting screws (not provided).
4. Refer to "Connecting Hubs to the Stack's Backplane" on page 16.

**Figure 2-1. Mounting the Hub in a Rack**

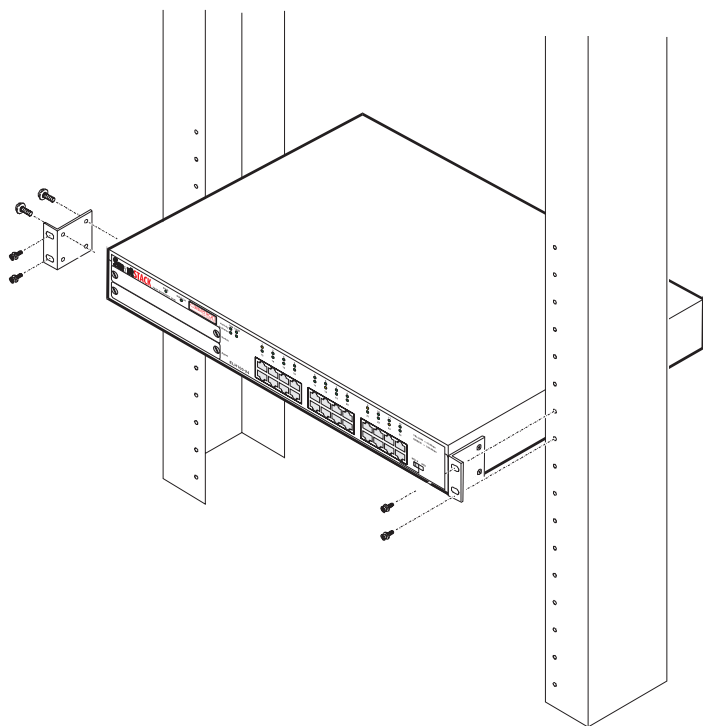

# Connecting Hubs to the Stack's Backplane

The hub ships with a stack cable.



**The hubs support a power-off bypass feature which allows traffic to pass freely across the stack's backplane, even if one or more of the hubs are powered off.**

Figure 2-2 shows how the stack cables are cascaded between the hubs in a stack (rack). To connect up to six hubs to the backplane, plug one end of the stack cable in the "Out" port of the top hub and the other end of the "In" port of the next hub. Repeat this step for each hub in the stack (or rack). Form a simple chain starting at the Out port on the first hub and ending at the In port on the last hub.

**Figure 2-2. Connecting Hubs to the Stack's Backplane**

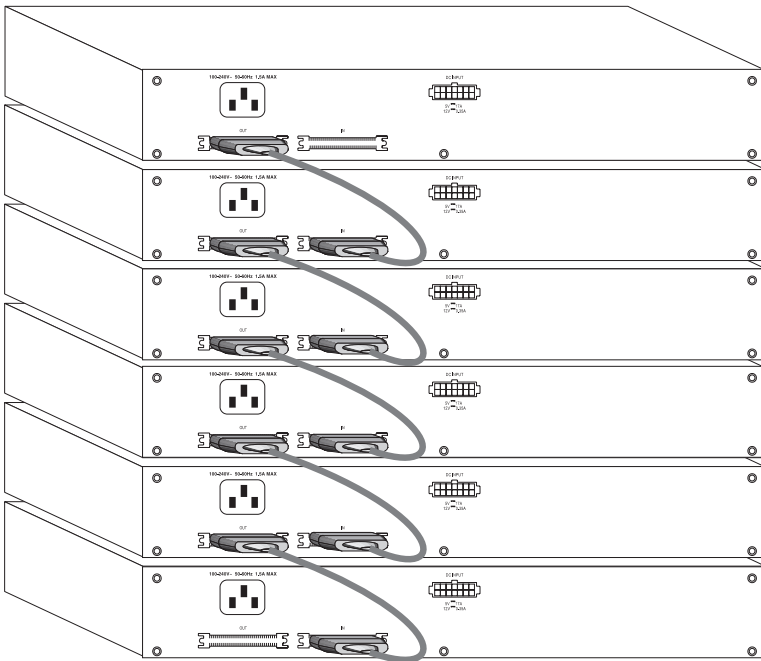

## Installing an Optional Module into the Hub

Optional modules are available for media extension and internal switching between repeater buses and management. These modules can be installed into the modular slots on the left side of the hub. The Agent Module must be installed in the lower slot, and all other modules in the upper slot.



**DO NOT** install slide-in modules with the hub powered on. Be sure you power off the hub before installing any module.

To install an optional module into the hub, do the following:

1. Disconnect power to the hub.
2. Remove the blank metal plate (or a previously installed module) from the appropriate slot by removing the two screws with a flat-head screwdriver. A switch/media module can be installed in the upper slot on the front of the hub. An Agent Module can be installed in the lower slot on the front of the hub.
3. Before opening the package that contains the module, touch the bag to the hub casing to discharge any potential static electricity.
4. Remove the module from the anti-static shielded bag.
5. Holding the module level, guide it into the carrier rails on each side and gently push it all the way into the slot, ensuring that it firmly engages with the connector.

**Figure 2-3. Installing an Optional Module into the Hub**

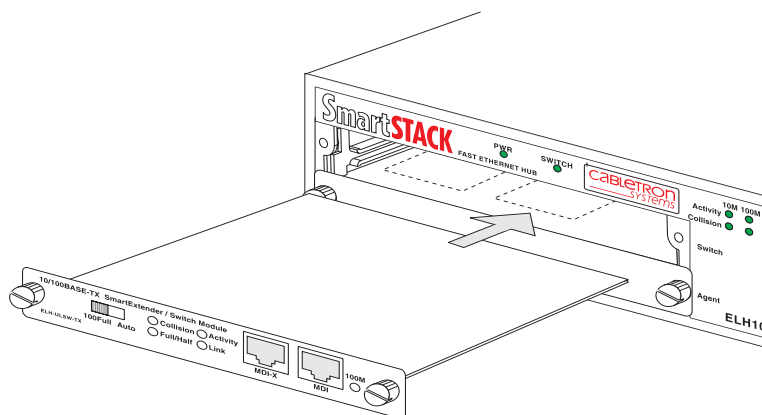

6. If you are sure the module is properly mated with the connector, tighten the retainer screws by hand to secure the module in the slot.
7. Connect power to the hub.

---

## Using a Switch/Media Module

The 10 and 100 Mbps repeater buses in the hub can be linked together by installing an optional switch/media module in the upper slot on the front panel. The switch/media module is used when traffic must be passed to a destination in the other segment, when broadcast traffic is sent, or when the destination is unknown. The switch/media module passes traffic between the source and destination segment at full duplex, using store-and-forward processing.

Multiple switch/media modules may be installed in a stack, but only one of the modules will actively bridge the 10/100 Mbps repeater buses. If the active switch/media module fails, it must be removed from the hub to activate the standby module.

**Table 2-1. Optional Modules**

Part Number	Functions	Description
ELH-ULSW-TX	10Base-T/ 100Base-TX, plus internal switching	Single-port RJ-45 uplink module using MDI-X and MDI connectors, with internal switching between the 10 and 100 Mbps repeater buses.
ELH-ULSW-F2	100Base-FX- MM, plus inter- nal switching	2-port MultiMode (MM) fiber uplink module using SC fiber connectors, with internal switching between the 10 and 100 Mbps repeater buses.
ELH100-SNMP	RMON/SNMP/ Web Manage- ment	Agent Module used to manage the hub (or attached stack). Includes RS-232 serial port for console connection. One backup agent module can be installed in the stack.

## Connecting a Terminal to the Console Port

The console port is a serial RS-232 interface port that enables a connection to a terminal for performing hub monitoring and configuration functions. The terminal may be a PC or workstation running terminal emulation software, or a terminal configured as a Data Terminal Equipment (DTE) connection. Alternatively, this port can be connected to an external modem to enable remote dial-in management. You can use the out-of-band management program (described in the next chapter) over a standard modem connection. Or, by running SLIP protocol over a modem connection, you can use in-band management applications such as the Web agent embedded in the Agent Module or third-party SNMP network management software.

If you connect a terminal to the console port prior to powering on the hub, you can observe the progress and results of the power-up diagnostics as the hub goes through its initialization process.

The console port connector is configured as a male null modem connection using a male DB-9 (see Table A-1 for pinouts). A standard straight-through wired RS-232 cable is supplied with the Agent Module for connecting to this interface. This cable is shielded to comply with emissions regulations and requirements.

### Console Port (Out-of-Band) Connections

To connect the ELH100-12/24TX console port to a terminal, do the following:

1. Connect a VT100 compatible terminal or a PC running a terminal emulation program to the console port (Figure 2-4). Use the null-modem cable provided with the Agent Module, or use a null modem connection that complies with the wiring assignments shown in Appendix A.

**Figure 2-4. Connecting a Terminal to the Console Port**

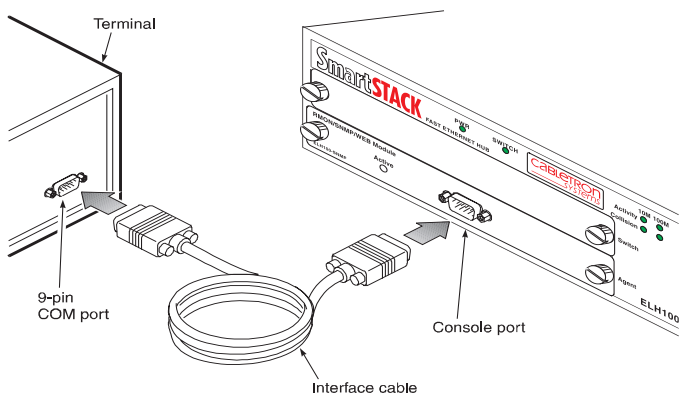

2. Connect one end of the interface cable directly to the Agent Module's console port and tighten the retaining screws.
3. Connect the other end of the interface cable to a terminal (in some instances, an adapter may be required to make this connection).
4. From your terminal, start the terminal emulation program.
5. Configure the terminal to the following communication settings:  
VT100 emulation, 9600 baud, no parity, 8 data bits, 1 stop bit, no flow control, ASCII character set.

## Remote Management via the Console Port

**Configure the Hub Site** - Connect the Agent Module's DB-9 serial port to the modem's serial port using standard cabling. For most modems using a 25-pin port, you will have to provide an RS-232 cable with a 9-pin connector on one end and a 25-pin connection on the other end. You do not have to set the modem at the hub's site, because the hub will automatically configure it to auto-answer mode.

**Configure the Remote Site** - At the remote site, connect the PC's COM port (COM 1~4) to the modem's serial port. Set terminal emulation type to VT100, specify the port used by your PC (i.e., COM 1~4), then set communications to 8 data bits, 1 stop bit, no parity, 9600 bps, and no flow control.

## In-Band Connections

Prior to accessing the Agent Module via a network connection, you must configure it with a valid IP address, subnet mask, and default gateway using an out-of-band connection or the BOOTP protocol.



**The Agent Module will automatically issue BOOTP requests if the IP address is set to "0.0.0.0". BOOTP is disabled if a valid IP address has been set. Refer to System Configuration Menu on page 33.**

**Telnet Connection** - Prior to accessing the Agent Module via an in-band Telnet connection, you must configure it with a valid IP address, subnet mask, and default gateway using an out-of-band connection or the BOOTP protocol. After configuring the hub's IP parameters, you can access the on-board configuration program from anywhere within the attached network.

**In-Band Network Connection** - The on-board configuration program can be accessed using Telnet from any computer attached to the network. The hub and stack can also be managed by any computer using a web browser (Internet Explorer 3.0 or above, or Netscape Navigator 3.0 or above), or from a network computer using third-party network management software.

---

You can also make a remote network connection (via modems) to the serial port on the Agent Module using SLIP protocol over TCP/IP. Using this kind of connection, the system functions similar to a router, allowing you to manage the hub or other attached devices using Telnet, a web browser, or network management software.



**Prior to accessing the hub via a SLIP connection, first configure it with a valid SLIP IP address, subnet mask, and default gateway.**

**The on-board program only provides access to basic configuration functions. To access the full range of SNMP management functions, you must use SNMP-based network management software.**

## Agent Module

Table 2-2 provides information for the Agent Module available for the ELH100-12/24TX.

**Table 2-2. Agent Module**

Part Number	Functions	Description
ELH100-SNMP	RMON/SNMP/ Web Manage- ment	Agent Module used to manage the hub (or attached stack). Includes RS-232 serial port for console connection. One backup agent module can be installed in the stack.

---

## Powering the Hub

To supply power to the hub, connect the power cord to the hub and to a grounded three-prong wall outlet (Figure 2-5). See Appendix A "Technical Specifications" on page 91 for more information regarding specific international power cord requirements.

**Figure 2-5. Connecting the Power Cord**

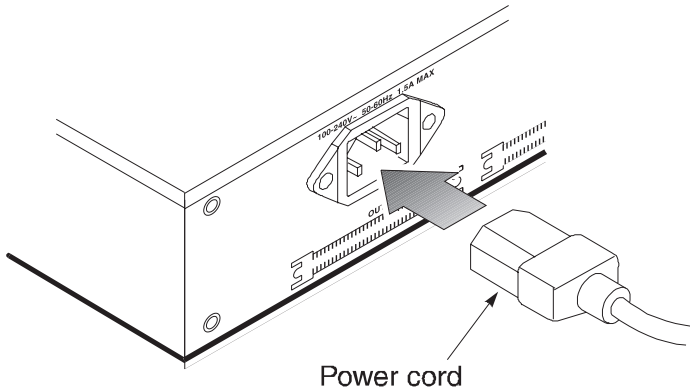

The PWR LED lights green (see Figure 1-1). If it does not, check to make sure that the power cable is plugged in correctly and that the power source is good.

When power is applied, the hub conducts a series of hardware and software tests to verify operation. If a terminal or computer is connected to the console port, the results of the tests are displayed on the screen. If you want to display the results of the tests after the hub has been turned on, turn the power to the hub off then back on.

The hub performs two basic types of tests at power-up. During this time, all the LEDs light in sequence. These tests are:

- **Serial port**  
The serial console port test is the first test. If the hub fails, no further tests are performed and the console displays no information.
- **Memory**  
Memory tests on the CPU RAM are performed after the serial port test. No results are displayed on the console.

After these tests are performed, the operational software of the hub is loaded. A series of more extensive diagnostic tests are then conducted. The results of the tests are displayed on the terminal. If all tests pass, the LEDs return to normal operation. When all tests are complete, the system is functional and the user interface is ready to receive commands at the console.



---

## Network Cable Requirements

### Copper

Table 2-3 specifies the cable types and length constraints for the various copper interfaces on the ELH100-12/24TX.

**Table 2-3. Copper Cable Specifications**

Interface Type	Cable Requirement	Maximum Length
10Base-T	Category 3 or 5 Unshielded Twisted Pair (UTP)	100m (328 ft.)
100Base-TX	Category 5 UTP	100m (328 ft.)

### Fiber

Table 2-4 specifies the fiber types, bandwidth requirements, and length constraints for the Fast Ethernet fiber interface on the fiber optic switch/media modules.

**Table 2-4. Fast Ethernet Fiber Specifications**

Interface Type	Fiber Type	Fiber Diameter (microns)	Maximum Length (m)
100Base-FX (SC connectors)	multi-mode	62.5	2,000m (6,560 ft.)

---

## 10Base-T/100Base-TX Ports

The 10Base-T/100Base-TX ports use RJ-45 connectors. Figure 2-6 shows an RJ-45 connector being inserted into a port.

**Figure 2-6. Inserting an RJ-45 Connector into a Port**

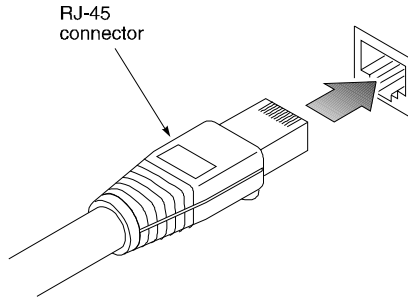

The ports on the base unit are wired with the MDI-X function implemented. These ports interface to UTP cabling for connection to 10Base-T or 100Base-TX network segments or end-stations. These UTP connections meet the requirements of ISO 8877, specified by 10Base-T, Section 14 of the IEEE 802.3 specification. Workstations or servers can be connected to these ports using standard straight-through wired cables.

For connections to other hubs or switches, Port 12 (24) on the ELH100-12TX (ELH100-24TX) hub includes a switch for MDI or MDI-X selection. If an MDI port is not available on the hub, a crossover cable may be necessary (refer to MDI/MDI-X Crossover Cable Wiring on page 94). See Table A-2, "10Base-T/100Base-TX Pinouts," on page 93 for 10Base-T/100Base-TX connector pin assignments.

The 10Base-T/100Base-TX switch/media module includes one port wired for MDI-X and one port wired for MDI. You can not use both ports on the module at the same time.

Table 2-5 provides information for the single port 10Base-T/100Base-TX uplink module available for the ELH100-12/24TX.

**Table 2-5. 10Base-T/100Base-TX Uplink Module**

Part Number	Functions	Description
ELH-UFSW-TX	10Base-T/ 100Base-TX	Single port RJ-45 uplink module using MDI-X and MDI connectors, with internal switching between the 10 and 100 Mbps repeater buses.

---

## 100Base-FX Fiber Ports

The 100Base-FX Fiber port uses SC connectors. Figure 2-7 shows an SC fiber connector being inserted into a fiber port on the ELH100-12/24TX.

**Figure 2-7. Inserting an SC Fiber Connector into a Fiber Port**

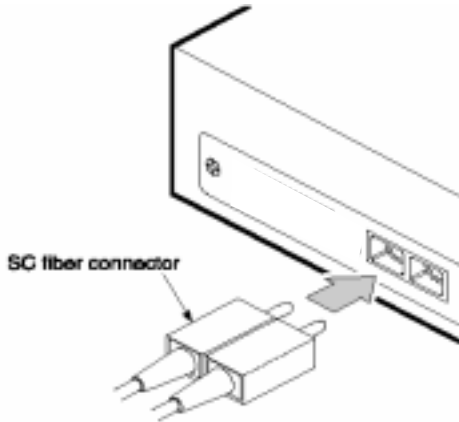

The fiber uplink modules employed (Table 2-6) support multi-mode 62.5/125mm fiber. The 100Base-FX ports use SC fiber connectors. The fiber connectors are configured as a receive (RX) / transmit (TX) pair.

**Table 2-6. Fiber Uplink Module**

Part Number	Functions	Description
ELH-ULSW-F2	100Base-FX-MM	2-port multi-mode (MM) fiber uplink module using SC fiber connectors, with internal switching between the 10 and 100 Mbps repeater buses.



---

### 3. ELH100-12/24TX USER INTERFACE

---

#### Overview

Access is gained to the console menus by connecting a terminal to the console port (with a direct cable connection or over modems), or using Telnet to access the Agent Module over the network. These menus allow you to reconfigure the hub, as well as to monitor the status and performance of the hub or the attached stack. The menus have a layout similar to the sample Main Menu shown in Figure 3-1. The information is divided into the following parts:

- Menu Name (includes access privileges)
- Selectable Items
- Screen Prompt for menu selections and entry of field parameters, and Message Area for display of parameters or error messages.

**Figure 3-1. Sample Main Menu**

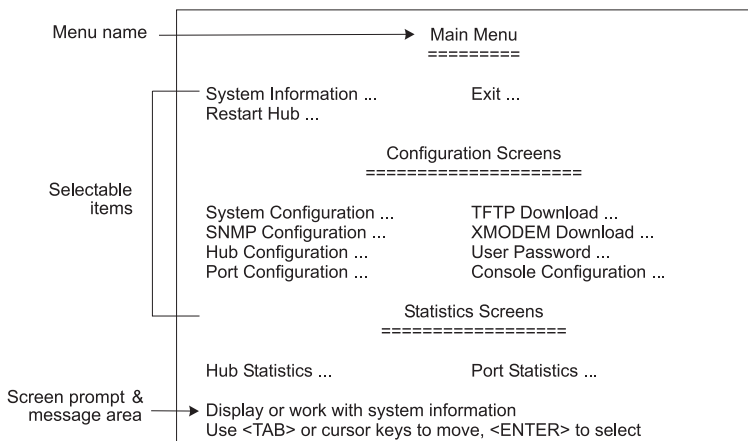

---

## User Access

Once a direct connection to the serial port or a Telnet connection is established, the login screen for the on-board configuration program appears. You may need to press Enter a few times to display the screen.

The default user names are “admin” and “guest,” with corresponding default passwords “admin” and “guest.” The administrator has Read/Write access, which allows you to read and modify hub information. The guest has Read Only access to the management program, which allows you to view hub information, but not modify any operating parameters.

You should define a new administrator password, record it and put it in a safe place. From the Main Menu, select User Passwords and enter a new password for the administrator. Passwords can consist of up to 14 alphanumeric characters and are not case sensitive.



**A user is allowed three attempts to enter the correct password; on the third failed attempt the current connection is terminated.**

To use the console menus, do the following:

1. Use the cursor keys to highlight the desired option.

If the selected item is a submenu title, the submenu is displayed when you press the Enter key.

2. Follow the screen prompts to specify the parameter requested.

If the selected item is a parameter, the system displays a prompt for the entry of a new parameter value. If the value entered is invalid, a message displays, requesting you to enter a valid value.

## Factory Defaults

Table 3-1 lists the default settings for the hub configuration parameters. Each parameter can be changed via the console menus or Telnet.

**Table 3-1. Factory Default Settings**

Parameter	Default Value
BootP Enable	Yes
Port Enable	Yes
Screen Timeout	10
Send Modem Initialization String (ATQ0V0S0=1)	Yes
SNMP Public Community Name	public
Terminal Baud Rate	9600
Terminal Hardware Flow Control	No

# Menu Hierarchy

Figure 3-2 shows the ELH100-12/24TX user interface menu hierarchy.

**Figure 3-2. ELH100-12/24TX User Interface Menu Hierarchy**

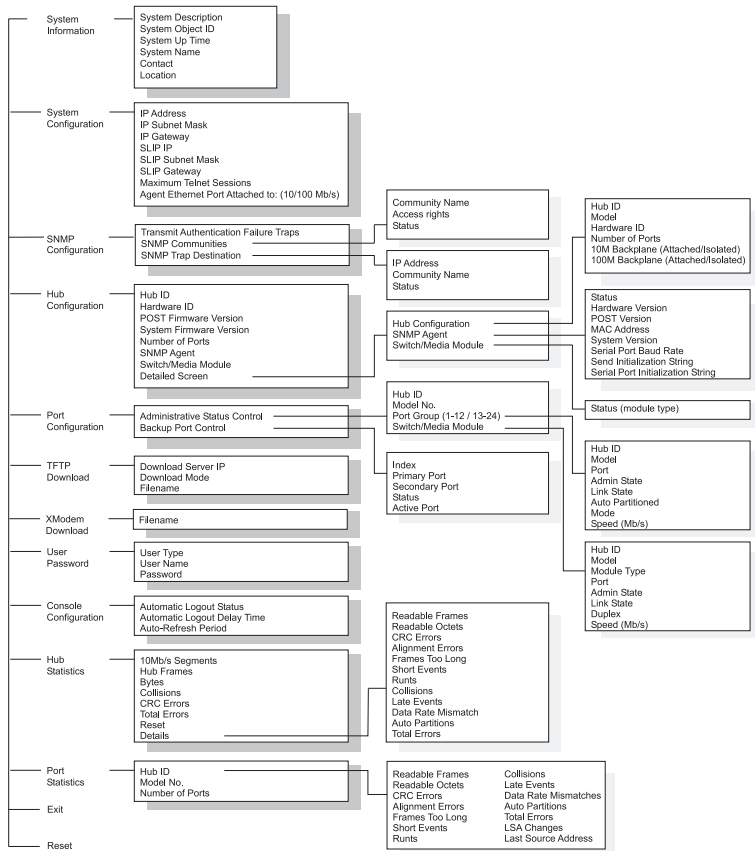

# Main Menu

The Main Menu is the first screen seen after successfully logging in to the system. Figure 3-3 shows the Main Menu and the accompanying table describes the Main Menu.

**Figure 3-3. Main Menu**

Main Menu	
=====	
System Information ...	Exit ...
Restart Hub ...	
Configuration Screens	
=====	
System Configuration ...	TFTP Download ...
SNMP Configuration ...	XMODEM Download ...
Hub Configuration ...	User Password ...
Port Configuration ...	Console Configuration ...
Statistics Screens	
=====	
Hub Statistics ...	Port Statistics ...
Display or work with system information	
Use <TAB> or cursor keys to move, <ENTER> to select	

Selection	Description
System Information	Provides system description, including system name and other data.
Restart Hub	Performs a software reset of the management agent for all hubs in stack or for a selected hub by restarting the system software and reloading certain operating parameters.
Exit	Logs out of the console interface. Once you log out, you must enter a user name and password before you can access the console interface again.
System Configuration	Configures IP parameters, including address, subnet mask, gateway, SLIP IP, default bootup IP. Specifies maximum number of Telnet sessions. Specifies the SNMP agent's segment.
SNMP Configuration	Configures communities and trap destinations.
Hub Configuration	Displays hardware/firmware versions for hub, isolates/attaches hub's repeater segments, and shows if an Agent Module or switch/media module is installed. If an Agent Module is installed, shows its bootup option, MAC address, hardware/firmware versions, and the Baud rate of the serial port.
Port Configuration	Disables/enables any port; and sets communication mode to 10 or 100 Mbps, or auto-sensing.
TFTP Download	Downloads new firmware version to update the Agent Module over the network.



XMODEM Download	Downloads new firmware to update the Agent Module via a console interface.
User Password	Sets Administrator and Guest names and passwords used for system access.
Console Configuration	Sets console time-out and refresh period for displayed statistics.
Hub Statistics	Displays network performance for each hub in the stack.
Port Statistics	Displays network performance for the selected port.

## System Information Menu

Use the System Information menu to display descriptive information about the hub, or for quick system identification. Figure 3-4 shows and the accompanying table describes the System Information menu.

**Figure 3-4. System Information Menu**

```

                                System Information
                                =====
System Desc.: Cabletron ELH100 Dual Speed Hub

Sys. Obj. ID: 1.3.6.1.4.1.52.3.9.1.10.5

Sys. Up Time: 6213437 (0 day 17 hr 15 min 34 sec)

System Name:

Contact:   Cabletron Inc., 0021-516-435-6475

Location:

                                <APPLY>      <OK>      <CANCEL>

                                Type the system name character string
                                Use <TAB> or cursor keys to move, <ENTER> to select,
                                <Ctrl-F> to move forward a character, <Ctrl-B> to move back a character

```

Selection	Description
System Description	System hardware description.
System Object ID	Object identifier for the hub's network management subsystem as defined in MIB II.
Sys. Up Time	Time since the hub was powered on.
System Name*	Name assigned to the hub system.
Contact*	Contact person for the system.
Location*	Specifies the area or location where the system resides.

**\* Maximum string length is 255, but the screen only displays 44 characters. You can use the arrow keys to browse the whole string.**

---

## Reset

Use the Restart Hub command under the Main Menu to reset the management agent. The reset screen includes an option to return all configuration parameters to their factory defaults.



**The hub takes approximately two minutes to restart. There is no apparent activity during this time. You should wait until the restart has completed.**

## Exit

Use the Exit command under the Main Menu to log out of the user interface and terminate communications with the hub for the current session. After this command is entered, system logout occurs automatically.

# System Configuration Menu

Use the System Configuration menu to configure the Agent Module's Internet Protocol (IP) parameters, define the maximum number of Telnet sessions allowed, and specify to which segment (10 Mbps or 100 Mbps) the management agent is attached. Figure 3-5 shows and the accompanying table describes the System Configuration Menu.

**Figure 3-5. System Configuration Menu**

```

System Configuration
=====

Parameter          Current Setting    New Setting
-----
IP Address:        210.68.150.225    210.68.150.225
IP Subnet Mask:    255.255.255.0     255.255.255.0
IP Gateway:        0.0.0.0           0.0.0.0

SLIP IP:           0.0.0.0           0.0.0.0
SLIP Subnet Mask: 0.0.0.0           0.0.0.0
SLIP Gateway:     0.0.0.0           0.0.0.0

-----

Maximum number of allowed Telnet sessions (0 - 2) : 2

Agent Ethernet Port Attached to: 100 Mb/s

    <APPLY>          <OK>              <CANCEL>

Type the new IP address

Use <TAB> or cursor keys to move, <SPACE> to toggle, <ENTER> to select,
<Ctrl-F> to move forward a character, <Ctrl-B> to move back a character
  
```

Selection	Description
IP Address	IP address of the agent you are managing. Valid IP addresses consist of four numbers (0 to 255) separated by periods. Anything outside of this format will not be accepted by the configuration program. If the IP address is set to 0.0.0.0 (the default), the SNMP agent will automatically issue BOOTP requests to a BOOTP server to learn its IP address. BOOTP requests will be disabled by configuring the agent with a valid IP address.
Subnet Mask	Subnet mask of the management agent you have selected. This mask identifies the host address bits used for routing to specific subnets. (The default subnet mask is 0.0.0.0.)
Default Gateway	Gateway used to pass trap messages from the management agent to the network management station. Note that the gateway must be defined if the management station is located in a different IP segment. (The default gateway is 0.0.0.0.)

---

SLIP IP	IP address of the Agent Module used when accessing the configuration program via an out-of-band SLIP connection to the serial port.  The hub does not allow the SLIP IP address to be the same as the IP address.
SLIP Subnet Mask	Subnet mask for the SLIP IP address used by the Agent Module.
SLIP Gateway	SLIP gateway IP address used to pass traffic to the network management station. Note that the gateway must be defined if the management station is located in a different IP segment.
Max # of allowed Telnet sessions	The maximum number of Telnet sessions allowed to simultaneously access the Agent Module.  <b>Note:</b> The maximum number of management sessions (not necessarily Telnet sessions) is 2.
Agent Ethernet Port Attached to	The network segment (10 Mb/s or 100 Mb/s) to which the Agent Module is attached.

---

---

## SNMP Configuration Menu

Use the SNMP Configuration Menu to display and modify parameters for the Simple Network Management Protocol (SNMP). The Agent Module monitors the hardware status of the hub (or connected stack), as well as the traffic passing through the ports. A Network Management Station (NMS) can access this information using third-party network management software. Access rights to the management agent are controlled by community strings. To communicate with the management agent, the NMS must first submit a valid community string for authentication. The options for configuring community strings and related trap functions are described in Figure 3-6, Figure 3-7, and Figure 3-8 and their accompanying tables.

**Figure 3-6. SNMP Configuration Menu**

```
SNMP Configuration
=====

Transmit Authentication Failure Traps: YES

SNMP Communities ...

SNMP Trap Destinations ...

<APPLY>      <OK>      <CANCEL>

Press <ENTER> to go to the SNMP Communities Screen

Use <TAB> or cursor keys to move, <SPACE> to toggle, <ENTER> to select
```

Selection	Description
Transmit Authentication Failure Traps	Issue a trap message whenever authentication of an SNMP request fails. The default is to issue traps to specified IP trap managers.
SNMP Communities	Assigns SNMP access based on specified community strings.
SNMP Trap Destinations	Specifies management stations that will receive authentication failure messages or other trap messages from the hub.

---

## SNMP Communities

**Figure 3-7. SNMP Communities**

SNMP Communities  
=====

Community Name	Access	Status
1. public	READ/WRITE	Enabled
2.		
3.		
4.		
5.		

<APPLY>            <OK>            <CANCEL>

Type a community name, 20 characters or less

Use <TAB> or cursor keys to move, <SPACE> to toggle, <ENTER> to select,  
<Ctrl-F> to move forward a character, <Ctrl-B> to move back a character

Selection	Description
Community Name	The community name for read only SNMP access to the device (1-10 character range; the default name is: "public").
Access	Management access is Read Only or Read/Write.
Status	Indicates operational status of the community as Enabled or Disabled.

---

## SNMP Trap Destinations

**Figure 3-8. SNMP Trap Destinations**

SNMP Trap Destinations		
IP Address	Community Name	Status
-----	-----	-----
1.		
2.		
3.		
4.		
5.		
6.		
7.		
8.		
9.		
10.		
<APPLY>	<OK>	<CANCEL>
Type an IP address for a trap destination		
Use <TAB> or cursor keys to move, <SPACE> to toggle, <ENTER> to select, <Ctrl-F> to move forward a character, <Ctrl-B> to move back a character		

Selection	Description
IP Address	The IP address of the trap destination where SNMP trap messages are forwarded.
Community Name	The SNMP community name to use for traps forwarded to the trap destination.
Status	Indicates status of entry as Enabled or Disabled.

# Hub Configuration Menus

Use the Hub Configuration menu to configure any hub in the stack. This menu is used to configure the selected hub, as well as the Agent Module. Use the following menu to view a basic description of all the hubs in the stack, including hardware and firmware version numbers, or to open a more detailed configuration screen for a specific hub. The information provided by these screens is described in Figure 3-9 and Figure 3-10, and the accompanying tables.

**Figure 3-9. Hub Selection Menu**

```

Hub Configuration: Hub Selection Menu
=====
Hub Hardware  POST  SYSTEM Num  SNMP  Switch/Media  Detailed
ID   ID      F/W Ver F/W Ver  Ports  Agent      Module        Screen
-----
1  110000001CC8  1.00   1.00   12   Active  ELH-ULSW-TX <DISPLAY DETAILS>

<PREV_SCREEN>

Press <ENTER> to go to a more detailed screen for this hub
Use <TAB> or cursor keys to move, <ENTER> to select
    
```

Selection	Description
Hub ID	Hub identifier in stack. (Up to 6 hubs may be connected via the stack cable.)
Hardware ID	Hardware version number of the repeater board.
Post Firmware Version	Version number of the repeater firmware in permanent memory.
System Firmware Version	Version number of the repeater firmware in temporary memory.
Number of Ports	Indicates whether this device has 12 or 24 repeater ports.
SNMP Agent	Indicates whether an Agent Module is installed in this hub.
Switch/Media Module	Indicates which switch/media module is installed in this hub.
Detailed Screen	Highlight "Display Details" and press <Enter> to access the configuration parameters for the hub.



**Figure 3-10. Hub Configuration Menu**

```

                                Hub Configuration
                                =====
Hub ID:          1                Model:    ELH100-12TX
Hardware ID:    11-00-00-00-1C-C8   Number of Ports: 12
10M backplane: Isolated            100M backplane: Isolated

                                SNMP Agent
                                =====
Status:         Active            H/W Ver:   0
POST Ver:      1.00              MAC Address: 00-00-1D-3F-2A-E1
System Ver:    1.00
Serial Port Baud Rate: 9600      Send Initialization String: NO
Serial Port Initialization String: ATQOV0S0=1

                                Switch/Media Module
                                =====
Status: Not present

                                <APPLY>    <OK>    <CANCEL>
                                Isolate or attach the 10 Mb/s segment

Use <TAB> or cursor keys to move, <SPACE> to toggle, <ENTER> to select,
<Ctrl-F> to move forward a character, <Ctrl-B> to move back a character
    
```

Selection	Description
<i>Hub Configuration</i>	
Hub ID	Hub identifier in stack.
Hardware ID	Serial number of this hub.
10M Backplane	Attaches/isolates hub's 10 Mbps repeater bus from the stack's data channel.
Model	The model number of this hub.
# of Ports	Indicates whether this device has 12 or 24 repeater ports.
100M Backplane	Attaches/isolates hub's 100 Mbps repeater bus from the stack's data channel.
<i>SNMP Agent</i>	
Status	Indicates if an Agent Module is installed and active.
POST Version	Version number of the Agent Module's Power-on Self-test.
System Version	System firmware version.
Serial Port Baud Rate	Rate at which data is sent between the Agent Module's serial port and the connected device. The supported baud rate is 9600 bps.
Serial Port Initialization String	The modem initialization string sent from the serial port to the attached device.
H/W Version	Hardware version number of the Agent Module.
MAC Address	Physical address of the Agent Module.

---

Serial Initialization  
String

Yes, to send the initialization string to an attached modem.  
No, if there is a direct connection from the serial port to a  
PC.

*Switch Module*

Status

Indicates if a switch/media module is installed.

---

## Port Configuration Menu

Select Administrative Status Control from the Port Configuration screen, then select the port group to configure, either “1 thru 12,” “13 thru 24,” or “Switch/Media Module” (if installed). The following screens show the configuration options.

### Port Administrative Status Control Menu

**Figure 3-11. Port Administrative Status Control Menu**

Port Administrative Status Control (1 - 12)					
=====					
Hub ID: 1		Model: ELH100-12TX			
Port	Admin State	Link State	Auto Partitioned	Mode	Speed (Mb/s)
-----					
1	Enabled	No Link	No	Auto	
2	Enabled	No Link	No	Auto	
3	Enabled	No Link	No	Auto	
4	Enabled	No Link	No	Auto	
5	Enabled	No Link	No	Auto	
6	Enabled	No Link	No	Auto	
7	Enabled	No Link	No	Auto	
8	Enabled	No Link	No	Auto	
9	Enabled	No Link	No	Auto	
10	Enabled	No Link	No	Auto	
11	Enabled	No Link	No	Auto	
12	Enabled	Link	No	Auto	100
<p>&lt;APPLY&gt;   &lt;OK&gt;   &lt;CANCEL&gt;   &lt;PREV_SCREEN&gt;   &lt;NEXT_SCREEN&gt;            Use the space bar to toggle states</p> <p>Use &lt;TAB&gt; or cursor keys to move, &lt;SPACE&gt; to toggle, &lt;ENTER&gt; to select</p>					

Selection	Description
Admin State	Allows you to disable a port due to abnormal behavior such as excessive collisions, and re-enable it after the problem has been resolved. You may also disable a port for security reasons.
Link State	Indicates if the port has a valid connection to an external device.
Auto Partitioned	Indicates if the port is partitioned.
Mode	Sets the transmission speed to 10 Mbps, 100 Mbps or auto-detection.
Speed	Indicates the transmission speed currently used by this port.

## Module Port Configuration Menu

The switch/media module configuration menu is accessible only if a module is installed in the hub's upper slot. The switch/media modules have two internal ports that are connected to the hub's internal repeater segments. The configuration screen and options are displayed below.

**Figure 3-12. Switch/Media Module Port Administrative Status Control Menu**

```

Port Administrative Status Switch/Media Module
=====

Hub ID: 1

Model: ELH100-12TX

Module Type: TX 10/100 Switch/Media Module

Port  Admin State  Link State  Duplex  Speed (Mb/s)
----  -
1     Int: Enabled   Link       Half    100
2     Ext: Enabled   Link       Half    10
3     Ext: Enabled   Link       Full    100

                <APPLY>      <OK>      <CANCEL>

Use the space bar to toggle between enabled and disabled states

Use <TAB> or cursor keys to move, <SPACE> to toggle, <ENTER> to select
  
```

Selection	Description
Module Type	The type of module installed in the hub.
Port	Port identifier for the module. Ports 1 and 2 link internally to the hubs 100 Mbps and 10 Mbps repeater segments. Port 3 is the external port on the module's front panel.
Admin State	The module's internal ports can be disabled to isolate the module from the hub. You may wish to do this if the module's external connection is exhibiting abnormal behavior or for security reasons.
Link State	Indicates if the port has a valid connection.
Duplex	The communication mode currently used by the port, either half duplex or full duplex.
Speed	Indicates the transmission speed currently used by the port.

## Backup Port Control Menu

Select Backup Port Control from the Port Configuration screen to define up to 15 master/slave port pairs. If the connection to the master port fails, the slave port will automatically take over. For greater reliability, primary and secondary ports should be located on different hubs. The following screen and table show how to specify and activate port backup pairs.

**Figure 3-13. Backup Port Control Menu**

Backup Port Control						
Index	Primary Port		Secondary Port		Status	Active Port
1	Hub: --	Port: --	Hub: --	Port: --	-----	-----
2	Hub: --	Port: --	Hub: --	Port: --	-----	-----
3	Hub: --	Port: --	Hub: --	Port: --	-----	-----
4	Hub: --	Port: --	Hub: --	Port: --	-----	-----
5	Hub: --	Port: --	Hub: --	Port: --	-----	-----
6	Hub: --	Port: --	Hub: --	Port: --	-----	-----
7	Hub: --	Port: --	Hub: --	Port: --	-----	-----
8	Hub: --	Port: --	Hub: --	Port: --	-----	-----
9	Hub: --	Port: --	Hub: --	Port: --	-----	-----
10	Hub: --	Port: --	Hub: --	Port: --	-----	-----
11	Hub: --	Port: --	Hub: --	Port: --	-----	-----
12	Hub: --	Port: --	Hub: --	Port: --	-----	-----
13	Hub: --	Port: --	Hub: --	Port: --	-----	-----
14	Hub: --	Port: --	Hub: --	Port: --	-----	-----
15	Hub: --	Port: --	Hub: --	Port: --	-----	-----

<APPLY>   <OK>   <CANCEL>  
 Type the hub ID for the primary port  
 Use <TAB> or cursor keys to move, <SPACE> to toggle, <ENTER> to select

Field	Description
Index	Identifier for up to 15 backup port pairs.
Primary Port	Pair member serving as the primary link.
Hub	Hub ID for the master port.
Port	Port identifier for the master port.
Secondary Port	Pair member serving as the backup link.
Hub	Hub ID for the slave port.
Port	Port identifier for the slave port.
Status	Each backup pair can be set to Active or Inactive.
Active Port	Indicates if the primary or secondary port is handling the link.

---

## TFTP Download Menu

Use the TFTP Download menu to load software updates into the hub over the network. The download file should be an ELH100-12/24TX binary file from Cabletron; otherwise, the agent module will not accept it. The success of the download operation depends on the accessibility of the TFTP server and the quality of the network connection. After downloading new software, the agent module will automatically restart itself. Parameters shown on this screen are indicated in the following figure and table.

**Figure 3-14. TFTP Download Menu**

```

                                TFTP Download
                                =====

Download Server IP:    10.1.4.45

Download Mode:        Upgrade DRAM and reboot

Filename: cbt0209b.bin

                                <Start TFTP Download>

                                <APPLY>      <OK>      <CANCEL>

                                Enter the server's IP address

                                Use <TAB> or cursor keys to move, <SPACE> to toggle, <ENTER> to select

```

Selection	Description
Download Server IP	IP address of a TFTP server.
Download Mode	You can download to permanent flash ROM or temporary storage in RAM (for test purposes). However, if you download to temporary memory, this firmware will be lost upon power off.
Filename	The ELH100-12/24TX binary file to download.
Start TFTP Download	Issues request to TFTP server to download the specified file.



**After the TFTP download is completed, the hub takes approximately two minutes to restart. There is no apparent activity during this time. You should wait until the restart has completed.**

---

## XMODEM Download Menu

Use the Xmodem Download command to update available software in the hub via an out-of-band connection to the serial port on the Agent Module. The download file should be an ELH100-12/24TX binary file from Cabletron; otherwise, the agent module will not accept it. This command specifies direct download from an attached device via the serial port. You may download using any terminal emulation program that can transmit binary files using the XModem protocol. The parameters shown in this screen are indicated in the following figure and table.

**Figure 3-15. XMODEM Download Menu**

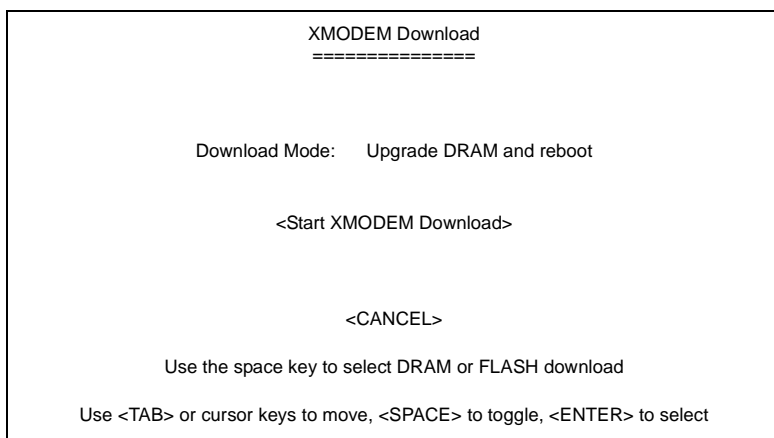

Selection	Description
Download Mode	You can download to permanent flash ROM or temporary storage in RAM (for test purposes). However, if you download to temporary memory, this firmware will be lost upon power off.
Start Xmodem Download	Waits to receive a file sent from the attached PC running the terminal emulation program.

To start the download process, use the XModem protocol and select the ELH100-12/24TX binary file. Start sending the file from your computer by using the “send” or “upload” file facility of the terminal emulation program. The terminal emulation program will display the progress of the download process. After downloading the new software, the agent will automatically restart itself.

## User Password Menu

The User Password menu is used to display or modify user names and passwords for the on-board configuration program. There are two user types, Administrator and Guest. Only the Administrator has write access for parameters governing the SNMP agent. You should therefore assign a user name and password to the Administrator as soon as possible, and store it in a safe place.

Passwords can consist of up to 14 alphanumeric characters and are not case sensitive. The configuration program will allow a user three attempts at entering a password before locking the user out by terminating the current connection. If for some reason your password is lost, or you can not gain access to the system configuration program, contact your Cabletron distributor for assistance.

**Figure 3-16. User Password Menu**

```

Display/Change User Names and Passwords
=====

User Type      User Name      Password      Password Verify
-----
Administrator: admin      *****      *****

Guest:         guest         *****      *****

                <APPLY>      <OK>      <CANCEL>

                Enter a user name, 1 to 14 characters

                Use <TAB> or cursor keys to move, <ENTER> to select,
                <Ctrl-F> to move forward a character, <Ctrl-B> to move back a character
    
```

Selection	Default	Description
Administrator	name: admin password: admin	Administrator has access privilege of Read/Write for all screens.
Guest	name: guest password: guest	Guest has access privilege of Read Only for all screens.



---

## Console Configuration Menu

The Console Configuration menu is used to configure the console connected to the hub's serial port. The console parameters are described in the following figure and table.

**Figure 3-17. Console Configuration Menu**

```

                                Console Configuration
                                =====

Automatic Logout Status:          ON

Automatic Logout Delay Time:      10 Minutes

Auto-Refresh Period:              30 Seconds

                                <APPLY>      <OK>      <CANCEL>

                                Use the space bar to toggle automatic logout

                                Use <TAB> or cursor keys to move, <SPACE> to toggle, <ENTER> to select

```

Selection	Description
Automatic Logout Status	Enables/disables the logout function.
Automatic Logout Delay Time	If no input is received from the attached device after this interval (in minutes), the current session is closed. Range: 0 - 99 minutes. Default is 10 minutes.
Auto-Refresh Period	Specifies the interval at which statistics are read from the hub. Options: 30, 60, 120, 180, 300 seconds. Default is 30 seconds.

# Hub Statistics Menu

The Hub Statistics screens display statistics for the 10 and 100 Mbps stack segments. These values can be used to indicate the approximate loading for each segment. You can use the Hub Statistics Overview screen to display key statistics for all hubs in a stack or detailed statistics for each individual hub. The Hub Statistics screens are shown in Figure 3-18 and Figure 3-19, and described in the accompanying tables.

**Figure 3-18. Hub Statistics Overview Screen**

```

Hub Statistics Overview
=====
10Mb/s Segments
Hub  Frames   Bytes   Collisions  CRC Errors  Tot.Errors  Reset      Details
-----
1    892     121329    0           0           0          <RESET1> <DETAIL>

100Mb/s Segments
Hub  Frames   Bytes   Collisions  CRC Errors  Tot.Errors
-----
1    736685  112506135  425         6           620

<REFRESH STATISTICS>  <AUTO-REFRESH STATISTICS>  <PREVIOUS SCREEN>
Press <ENTER> to reset both 10 and 100 Mbit statistics counters for this hub
Use <TAB> or cursor keys to move, <ENTER> to select
    
```

Field	Description
Hub	Hub identifier within the stack.
Frames	Number of frames passing through this hub.
Bytes	Number of bytes passing through this hub.
Collisions	Number of simultaneous node transmissions detected by this hub.
CRC Errors	Number of Ethernet Cyclic Redundancy Check errors detected by this hub.
Total Errors	Total number of errors, including FCS, alignment, Frames Too Long, Short Events, Late Events, Jabber, and Data Rate Mismatches detected on this device.
Reset	Resets the statistics counters for the hub.
Details	Highlight "Detail" and press <Enter> to display the detailed statistics screen for the hub.
Refresh Statistics	Refresh the displayed statistics.
Auto-Refresh Statistics	Refresh statistics at the interval specified in Console Configuration.

**Figure 3-19. Detailed Hub Statistics Screen**

Hub 1 Statistics		
Statistic	10 Mb/s Segment	100 Mb/s Segment
Readable Frames	433	763985
Readable Octets	86057	116973315
CRC Errors	0	6
Alignment Errors	0	1
Frames Too Long	0	0
Short Events	0	612
Runs	0	3
Collisions	2	425
Late Events	0	1
Data Rate Mismatch	0	0
Auto Partitions	0	1
Total Errors	0	620

<REFRESH STATISTICS> <AUTO-REFRESH STATISTICS> <RESET HUB STATISTICS>

<OVERVIEW SCREEN> <PREVIOUS HUB> <NEXT HUB>

Press <ENTER> to refresh this hub's statistics screen

Use <TAB> or cursor keys to move, <ENTER> to select

Field	Description
Readable Frames	Number of good frames passing through the hub.
Readable Octets	Number of good octets passing through the hub.
CRC Errors	Number of CRC errors detected by the hub.
Alignment Errors	The number of mis-synchronized data packets detected by the hub.
Frames Too Long	Number of times frame length has exceeded the maximum allowable size (that is, 1518 bytes).
Short Events	Number of short fragments.
Runs	Number of fragments (that were too long to qualify as short events).
Collisions	Number of simultaneous node transmissions detected by the hub.
Late Events	Number of frames where a collision occurred late in the transmission.
Data Rate Mismatch	Number of frames for which the data rate does not match the local frequency.
Auto Partitions	Number of times the hub has automatically partitioned ports due to jabber.
Total Errors	Total number of errors, including FCS, Alignment, Frames Too Long, Short Events, Late Events, Jabber, and Data Rate Mismatches detected on the hub.
Refresh Statistics	Refreshes the displayed statistics.
Auto-Refresh Statistics	Refreshes statistics at the interval specified in Console Configuration.
Reset Hub Statistics	Resets the statistics counter for all items to zero.

## Port Statistics Menu

Use the Port Statistics screen to display key statistics for each port. Overall statistics on the traffic passing through each port are displayed. This information can be used to identify potential problems with the hub (such as a faulty port).

Select the required port from the Port Statistics: Port Selection Menu. The Port Statistics Screen is shown in Figure 3-20 and described in the accompanying table.

**Figure 3-20. Port Statistics Screen**

Hub 1 Port 12 Statistics			
=====			
Readable Frames:	805490	Collisions:	425
Readable Octets:	123515227	Late Events:	1
CRC Errors:	6	Data Rate Mismatches:	0
Alignment Errors:	1	Auto Partitions:	1
Frames Too Long:	0	Total Errors:	620
Short Events:	612	LSA Changes:	672366
Runts:	3	Last Source Address:	00-00-E8-42-72-E4
<p>&lt;REFRESH STATISTICS&gt;   &lt;AUTO-REFRESH STATISTICS&gt;   &lt;RESET COUNTERS&gt;</p> <p>&lt;PORT SELECTION SCREEN&gt;   &lt;PREVIOUS PORT&gt;   &lt;NEXT PORT&gt;</p> <p>Press &lt;ENTER&gt; to refresh this port's statistics screen</p> <p>Use &lt;TAB&gt; or cursor keys to move, &lt;ENTER&gt; to select</p>			

Field	Description
Readable Frames	Number of good frames received by the port.
Readable Octets	Number of good octets received by the port.
CRC Errors	Number of CRC errors.
Alignment Errors	For 10 Mbps ports, the counter records alignment errors (mis-synchronized data packets). For 100 Mbps ports, the counter records the sum of alignment errors and code errors (frames received with rxerror signal).
Frames Too Long	Number of times frame length has exceeded the maximum allowable size (that is, 1518 bytes).
Short Events	Number of short fragments.
Runts	Number of fragments (that were too long to qualify as short events).
Collisions	Number of simultaneous node transmissions detected by this device.
Late Events	Number of frames where a collision occurred late in the transmission.
Data Rate Mismatches	Number of frames for which the data rate does not match the local frequency.

---

Auto Partitions	Number of times this port has been automatically partitioned due to jabber.
Total Errors	Total number of errors, including FCS, Alignment, Frames Too Long, Short Events, Late Events, Jabber, and Data Rate Mismatches detected on this device.
LSA Changes	Number of times the source address has changed.
Last Source Addr.	Last source address.
Refresh Statistics	Refreshes the displayed statistics.
Auto-Refresh Statistics	Refreshes statistics at the interval specified in Console Configuration.
Reset Counters	Resets the statistics counter for all items to zero.

---



---

## 4. CONFIGURING & MONITORING THE HUB

---

### Common Tasks

The hub console menus allow you to modify default hub settings and configure the hub for network management. They also allow you to monitor hub performance and status. See Chapter 3, ELH100-12/24TX User Interface on page 27, for an overview of the menu hierarchy and a description of all menus. The following sections describe common tasks in setting up and operating the ELH100-12/24TX hub using the console menus.

To begin, set operating parameters and make sure the network connections are correct by performing these tasks:

- Setting password protection for the hub to prevent unauthorized access to console menus
- Assigning an IP address for the hub if you plan to manage the hub using SNMP, or if you use Telnet to access the hub
- Checking network configuration status and verifying that network connections are correct

After the hub is installed and operating, you may want to perform any of the following tasks:

- Connecting via Telnet for in-band access to the console menus
- Setting SNMP parameters for management access
- Viewing hub statistics to monitor and evaluate hub performance and traffic patterns on the network
- Downloading a software upgrade
- Configuring port operation (enable/disable or set port speed)
- Setting a default gateway
- Configuring BootP

### Setting Password Protection

The ELH100-12/24TX hub is factory-configured with access rights to the console menus set to READ/WRITE for the administrator, and READ-ONLY for all others. These settings allow anyone who knows the hub's default user name and password to use the console menus to modify any operational parameter. To protect the configuration of the hub from unauthorized modification, you can change the password to the console menus.

---

To enter a password, do the following:

1. Select Password from the System Configuration Menu and press [Enter].
2. Enter a password containing 1 to 14 alphanumeric characters.

The password is not case sensitive. For verification, you are asked to enter your password again. If both entries agree, the new password is stored.

If you forget your password, contact your Cabletron System Support Representative.



**You are automatically logged out from the console menus due to inactivity based on the Automatic Logout Delay Time setting in the Console Configuration Menu.**

## Assigning an IP Address

To assign an IP address to the hub, do the following:

1. Select System Configuration Menu from the Main menu.
2. Select New Setting for IP address from the menu and enter the IP address. Select <APPLY>.

The IP address is now programmed. If necessary, select Subnet Mask from the menu and enter the appropriate mask.

## Checking Network Configuration Status

To check connection status for the network, do the following:

1. Select Port Configuration Menu from the Main Menu.

If a network cable is properly connected to a port, the Link Status for the port reads LINK. If no cable is connected to the port, or if the cable or port is faulty, the Link Status for the port reads NO LINK.

2. If you see NO LINK status for a connected port, plug the cable into another port on the hub or try another cable.



---

## Connecting via Telnet

You can connect to the ELH100-12/24TX hub from a remote location using the Telnet application. This application allows you to establish in-band access to the console menus.

To connect to the ELH100-12/24TX hub via Telnet, do the following:

1. Assign an IP address using the System Configuration Menu.
2. Log in to the ELH100-12/24TX hub via Telnet using the configured IP address.

## Setting SNMP Management Access

Access to the ELH100-12/24TX hub through SNMP is controlled by community names. The community names set for the hub must match those used by the SNMP management station for successful communication to occur. You can assign up to five community names to the hub using READ/WRITE or READ ONLY access. The default community name is "public," and provides read/write access to the hub.

The ELH100-12/24TX hub can send SNMP messages, called traps, to SNMP management stations when an important event occurs with the hub. The hub allows up to 10 destinations to be configured for these trap messages to be sent.

To configure SNMP access for the hub, do the following:

1. Select SNMP Configuration Menu from the Main Menu.
2. Select SNMP Communities from the SNMP Configuration Menu.
3. Specify a Community Name (you are permitted to enter from one to 10 characters), select the desired read/write access community name, and set Status to Enabled.
4. Select one or more Trap Destination entries from the menu, enter the appropriate IP addresses, and set Status to Enabled.
6. For each trap destination entered, a corresponding community name should be entered. (This community name must be defined in the SNMP Communities Menu.)

---

## Viewing Hub Statistics

To view hub statistics, do the following:

1. Select Hub Statistics from the Main Menu.  
The screen lists the main statistical counts for both segments on the hub simultaneously.
2. Select <DETAIL> from the Hub Statistics Overview screen.  
The screen lists a summary of sum total statistics for all ports on the hub.
3. Select Port Statistics from the Main Menu.
4. Enter the Hub ID and Port ID. Select <OK>.  
The screen lists expanded port-level statistics for an individual port.
5. On any of the statistics screens, select <RESET COUNTERS> to clear (zero) the displayed statistical counts and <REFRESH STATISTICS> to refresh (update) the displayed statistical counts.

## Downloading a Software Upgrade

You can upgrade the operational software in the ELH100-12/24TX hub without physically opening the hub or being in the same location. The software storage sector in the flash memory of the hub is reprogrammable, allowing you to easily download software feature enhancements and problem fixes to the hub from a local or remote location.

Software can be downloaded to the hub in two ways:

- Via the serial port. This procedure is an out-of-band operation that copies the software through the serial port to the hub. This operation takes approximately 40 minutes and requires minimal configuration.
- Via TFTP download. This procedure uses a TFTP server connected to the network and downloads the software using the TFTP protocol. A TFTP download is much faster than a serial download, requiring only a matter of minutes, and can be used to upgrade an ELH100-12/24TX hub that is not physically proximate. The disadvantage is that this method requires a TFTP server and additional setup.

### Downloading Via the Serial Port

A serial download is the easiest method to upgrade the ELH100-12/24TX hub software, requiring the least amount of equipment and configuration.

To download hub software via the serial port, do the following:

1. Select XMODEM Download from the Main Menu.
2. Select "Upgrade FLASH and reboot."
3. Select <Start XMODEM Download>.

- 
4. When the system prompts, confirm that you want to proceed.

The following message prompt displays:

```
Receiving image...
```

5. Send the file using the XMODEM protocol from your computer application (the procedure varies depending upon the application used).

When the XMODEM procedure finishes, a message appears stating that the system is initializing. The login prompt displays after the system initializes. If the login prompt does not display, you may need to press the Enter key several times.

## Downloading Via TFTP

To perform a TFTP download, you must first configure the ELH100-12/24TX hub. This consists of programming the hub with an IP address, if this has not already been done, and entering the IP address of the TFTP server and the name of the upgrade file. To program the hub IP address, go to the TFTP Download Menu which is accessible from the Main Menu screen.

To download hub software via TFTP, do the following:

1. Enter the Download Server IP address.
2. Set the Download Mode to "Upgrade FLASH and reboot."
3. Enter the filename to be downloaded from the TFTP server. Depending on the system you use as a TFTP server, you may need to include the directory name with the filename.
4. If necessary, configure the address of an IP gateway to reach the server from the hub using the IP Gateway field on the System Configuration Menu.
5. Configure the TFTP server by copying the download file to the appropriate directory and starting the server.
6. Select <Start TFTP Download> and press [Enter].

To verify that the TFTP download has been successfully completed, note the software version level displayed on the Hub Configuration screen accessible from the Main Menu. This number should match the version number of the downloaded file.

---

## Configuring Port Operation

You can configure 10/100 ports on the base unit for operational parameters such as enabled/disabled, and port speed or auto-sensing.

To configure port operation, do the following:

1. Select Port Configuration from the Main Menu.
2. Select Administrative Status Control from the Port Configuration menu.
3. Select Port Group 1-12, 13-24 or Switch/Media Module.
4. Highlight any port, and select "Enabled" or "Disabled" in the Admin State field to toggle between enabling and disabling the port(s).
5. Select "Force 10," "Force 100" or "Auto" under the Mode field to set the port speed to 10 Mbps, 100 Mbps or auto-detection.



**The console interface can only enable/disable the ports on switch/media modules. To configure the speed/mode, use the 100Full/Auto toggle switch on the 10Base-T/100Base-TX module or the Full/Half toggle switch on the 100Base-FX module.**

## Spanning Tree

The Switch/Media modules do not support Spanning Tree, which is intended to prevent network loops from forming. There is no loop detection.

The user is cautioned to understand and avoid configurations that can create a loop. However, if the ELH100-12/24TX is connected in a redundant link configuration to a single device which does support Spanning Tree, one link will be properly blocked, preventing a network loop from forming. This method can be used to provide a standby connection to the network backbone which will become active if the primary link is lost.

## Setting a Default Gateway

The Default Gateway parameter defines the IP address of a router or other network device which is on the same subnet as the hub. The gateway receives IP packets that are to be sent to another subnet.

To set a default gateway, do the following:

1. Select System Configuration Menu from the Main Menu.
3. Enter the gateway IP address under New Setting. Select <APPLY>.

---

## Configuring BootP

The BootP protocol allows you to automatically configure the hub's IP address information. Enabling this feature greatly speeds up device configuration, especially when a large number of devices are installed.

A BootP server must be operating on the network and be properly configured for this option to work. When this option is enabled, the hub tries to obtain an IP address from a BootP server.

To configure BootP, do the following:

1. Select System Configuration Menu from the Main Menu.
2. Set the IP address under the New Setting field to 0.0.0.0. This selection forces the hub to issue BootP requests when powered on.



---

## 5. WEB-BASED MANAGEMENT

---

As well as the menu-driven system configuration program, the Agent Module provides an embedded HTTP Web agent. This agent can be accessed by any computer on the network using a standard Web browser (Internet Explorer 3.0 or above, or Netscape Navigator 3.0 or above).

Using the Web browser management interface you can configure a hub (or stack attached via the backplane) and view statistics to monitor network activity. The Web interface also provides access to a range of SNMP management functions with its MIB and RMON browser utilities.

Prior to accessing the Agent Module from a Web browser, be sure you have first performed the following tasks:

1. Configure it with a valid IP address, subnet mask, and default gateway using an out-of-band serial connection or BootP protocol.
2. Set user names and passwords using an out-of-band serial connection. Access to the Web agent is controlled by the same user names and passwords as the on-board configuration program. The default user names are "admin" and "guest" with corresponding default passwords of "admin" and "guest."

### Navigating the Web Browser Interface

To access the Web-browser interface you are first required to enter a user name and password. As with the console interface program, there are two user types, Administrator and Guest. The Administrator has Read/Write access to all configuration parameters and statistics, while the Guest has Read Only access.

When your Web browser connects with the Agent Module's Web agent, the home page is displayed.

The home page displays the Main Menu on the left-hand side of the screen and the System Information on the right-hand side. The Main Menu links are used to navigate to other menus and display configuration parameters and statistical data.

Configurable parameters have a dialog box or a drop-down list. Once a configuration change has been made on a page, be sure to click on the "Apply" button at the bottom of the page to confirm the new setting. Alternatively, you can click on the "Cancel" button to clear any changes prior to pressing the "Apply" button.

---

# Main Menu



Menu	Description
System Information	Provides system description, including system name and other data.
Stack Browser	Provides a graphical representation of the stack, access to SNMP agent, hub and port parameters.
MIB Browser	Access to MIB II, Repeater MIB, Ethernet-Like MIB and Cabletron's private MIB parameters.
RMON Browser	Access to Statistics, History, Alarm and Event groups.
Help	Help on using the Web management interface.



# System Information

**System Information**

---

System Description	Cabletron ELH100 Dual Speed Hub
System Object ID	{1.3.6.1.4.1.52.3.9.1.10.5}
System Up Time	34hr(s)_16hr(s)_42min(s)_50sec(s)
System Name	<input type="text"/>
Contact	<input type="text"/>
Location	<input type="text"/>
System Services	1 physical (e.g. repeaters)

Field	Description
System Description	System hardware description.
System Object ID	Object identifier for the hub's network management subsystem as defined in MIB II.
Sys. Up Time	Time since the hub was last powered on.
System Name*	Name assigned to the hub system.
Contact*	Contact person for the system.
Location*	Specifies the area or location where the system resides.
System Services	Specifies services for the 7-layer network protocol.

**\* Maximum string length is 255, but the screen only displays 44 characters. You can use the arrow keys to browse the whole string.**

---

## Stack Browser



---

Item	Description
Stack	Displays the front panel graphic representation of all the hubs in a stack.
Agent	Access to configuration of IP address and SLIP IP address for the SNMP agent.
Hub	Displays hub configuration data and enables hub to be isolated from the stack backplane.
Port	Enables configuration of port parameters, sets port security and port backup features.
Switch Module	Access to the Switch/Media Module configuration and statistics.

---

---

## Front Panel

Select “Stack” then “Front Panel” to display a graphic image of the hub or attached stack.

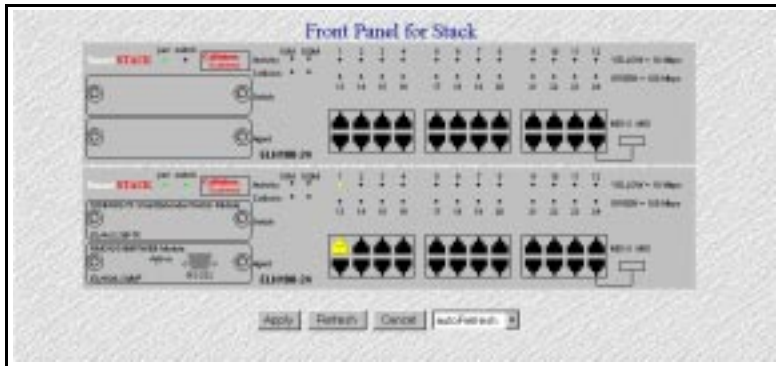

---

Item	Description
[Refresh]	Immediately refreshes front panel status.
Refresh Mode Select	The scroll-down window includes options for: “autoRefresh” of the front panel every 10 seconds, or “manual” refresh by pressing the [Refresh] button.

---

## Agent Configuration

Select “Agent” then “Agent Configuration” to display IP configuration and other information.

The screenshot shows a web browser window with the title "Stack Browser - Agent". The main content area is titled "Agent Configuration". It is divided into two sections: "New Setting" and "Current Used".

**New Setting:**

- IP Address: [18.1.7.222]
- Subnet Mask: [255.255.0.0]
- Gateway IP: [18.1.4.254]
- Slip IP: [0.0.0.0]
- Slip Subnet Mask: [0.0.0.0]
- Slip Gateway: [0.0.0.0]

**Current Used:**

- IP Address: 18.1.7.222
- Subnet Mask: 255.255.0.0
- Gateway IP: 18.1.4.254
- Slip IP: 0.0.0.0
- Slip Subnet Mask: 0.0.0.0
- Slip Gateway: 0.0.0.0

Agent Attached to: [100Mbps(\*)]

Buttons: [Apply] [Cancel]

Item	Description
IP Address	IP address of the Agent Module you are managing. Valid IP addresses consist of four numbers, of 0 to 255, and separated by periods. (The default address is 0.0.0.0.)
Subnet Mask	Subnet mask of the Agent Module you are managing. This mask identifies the host address bits used for routing to specific subnets. (The default subnet mask is 0.0.0.0.)
Gateway IP	Gateway used to pass trap messages from the management agent to the network management station. Note that the gateway must be defined if the management station is located in a different IP segment. (The default gateway is 0.0.0.0.)
SLIP IP	IP address of the Agent Module used when accessing the configuration program via an out-of-band SLIP connection to the serial port.
SLIP Subnet Mask	Subnet mask for the SLIP IP address of the Agent Module.
SLIP Gateway	SLIP gateway IP address used to pass traffic to the network management station. Note that the gateway must be defined if the management station is located in a different IP segment.
Agent Attached to	The network segment (10 Mbps or 100 Mbps) to which the Agent Module is attached.

---

## Hub Configuration

Select “Hub” then “Hub Configuration” to display hardware and firmware configuration of the hub.

The screenshot shows a window titled "Hub Configuration". At the top, there is a "Hub ID" field with a dropdown menu and a "Select" button. Below this is a list of configuration parameters and their values:

Hub ID	2
Model	ELH100-24TX
Hardware Version	2
Repeater Serial No.	11-00-00-00-5E-68
System Version	1.00
POST Version	1.0
Agent Status	Master
Agent Hardware Version	2
Agent Serial No.	61-00-00-00-00-00
Agent MAC Address	00-00-1D-DF-47-E2
Agent Baudrate	9600
Switch Module	Present
Number of Ports	24

At the bottom of the window, there are "Apply" and "Cancel" buttons.

Item	Description
Hub ID	Hub identifier in stack.
Model	The model number of this hub.
Hardware Version	Version number of the hub hardware.
Repeater Serial No.	Serial number of this hub.
System Version	System firmware version.
POST Version	Version number of the Agent Module's Power-on Self-test.
Agent Status	Indicates if an Agent Module is installed and active.
Agent Hardware Version	Hardware version number of the Agent Module.
Agent Serial No.	Serial number of the Agent Module.
Agent MAC Address	Physical address of the active Agent Module.
Agent Baud rate	Rate at which data is sent between the Agent Module's serial port and the connected device. The supported baud rate is 9600 bps.
Switch Module	Indicates if a switch/media module is installed.
Number of Ports	Indicates whether this device has 12 or 24 repeater ports.

---

## Hub Backplane

Select “Hub” then “Hub Backplane” to display information about the hub’s connection to the stack’s backplane.



The screenshot shows a web interface for configuring a hub's backplane. On the left is a 'Stack Browser - Hub' sidebar with a tree view containing 'Go Back', 'Hub Configuration', and 'Hub Backplane'. The main area is titled 'Hub Backplane Configuration' and contains the following fields:

- Hub ID: 1
- Backplane ID: 100Mbps (1) with a 'Select' button
- Hub ID: 1
- Backplane ID: 1
- Backplane Status: attached(2) with a dropdown arrow

At the bottom of the configuration area are 'Apply' and 'Cancel' buttons.

Item	Description
Hub ID	Hub identifier in the stack.
Backplane ID	The hub’s segment, 100 Mbps (1) or 10 Mbps (2). Select a segment to display/configure in the Backplane Status field.
Backplane Status	Select to isolate or attach the hub’s repeater bus to the stack backplane then press [Apply].

## Port Configuration

Select "Port" then "Port Configuration" to display information about the port's connection, or to display/configure the port's security setting.

Item	Description
Hub ID	Hub identifier in the stack.
Port ID	Port number to configure.
Current Speed	Indicates the transmission speed currently used by this port.
Set Speed	Selects the port speed, 100 Mbps, 10 Mbps or Auto-Detected.
Admin State	Allows you to disable a port due to abnormal behavior (e.g., excessive collisions), then re-enable it after the problem has been resolved. You may also disable a port for security reasons.
Link State	Indicates if the port has a valid connection to an external device.
Partition State	Indicates if the port is partitioned.
<i>Port Security Setting</i>	
Authentication Address	MAC address of the device authorized to access this port.
Auto-Learn Action	When active, the authorized address is copied from the device currently attached to this port.
Auto-Learn Status	Displays Auto-Learn status as Inactive, Active or Learned.
Intrusion	One of these actions can be selected if intrusion is detected:  INACTIVE - Detection disabled. WARNING AND DISABLE - Sends a message to Trap Managers and disables the violated port.

## Port Backup

Select "Port" then "Port Backup" to display/configure redundant links.

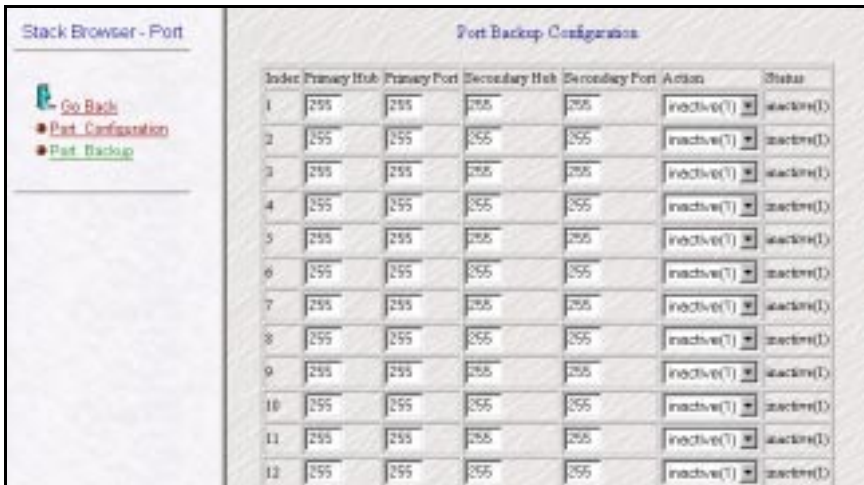

Index	Primary Hub	Primary Port	Secondary Hub	Secondary Port	Action	Status
1	255	255	255	255	Inactive(?)	active(D)
2	255	255	255	255	Inactive(?)	active(D)
3	255	255	255	255	Inactive(?)	active(D)
4	255	255	255	255	Inactive(?)	active(D)
5	255	255	255	255	Inactive(?)	active(D)
6	255	255	255	255	Inactive(?)	active(D)
7	255	255	255	255	Inactive(?)	active(D)
8	255	255	255	255	Inactive(?)	active(D)
9	255	255	255	255	Inactive(?)	active(D)
10	255	255	255	255	Inactive(?)	active(D)
11	255	255	255	255	Inactive(?)	active(D)
12	255	255	255	255	Inactive(?)	active(D)

Item	Description
Index	Identifier for up to 15 backup port pairs.
Primary Hub	Hub ID for the master port.
Primary Port	Port identifier for the master port.
Secondary Hub	Hub ID for the slave port.
Secondary Port	Port identifier for the slave port.
Action	Each backup pair can be set to Active or Inactive.
Status	Active is displayed if the backup port has taken over the link. Inactive is displayed if the primary port is still handling the link. Standby is displayed if there is no link on the primary port.



## Switch Module Statistics

Select "Switch Module" then "Switch Module Statistics" to display statistics for the switch/media module.

The screenshot displays the 'Switch Module Statistics' window. At the top, there is a 'Hub ID' dropdown menu set to '1' and a 'Select' button. Below this is a table with the following data:

Hub ID	Port ID	Readable Frames	Readable Octets	FCS Errors	Alignment Errors	Frames Too Long	Short Events	Runs	Collisions	Late Events	Very Long Events	Data Rate Mismatches	Broadcast Packets	Multicast Packets
1	1	0	0	0	0	0	0	0	0	0	0	0	0	0
1	2	5867	1520037	0	0	0	0	0	0	0	0	0	3649	484

At the bottom of the window, there are buttons for 'Apply', 'Refresh', 'Cancel', and an 'autoRefresh' dropdown menu.

Item	Description
Readable Frames	Number of good frames received by the port.
Readable Octets	Number of good octets received by the port.
FCS Errors	Number of FCS errors.
Alignment Errors	For 10 Mbps ports, the counter records alignment errors (mis-synchronized data packets). For 100 Mbps ports, the counter records the sum of alignment errors and code errors (frames received with rxerror signal).
Frames Too Long	Number of times frame length has exceeded the maximum allowable size (i.e., 1518 bytes).
Short Events	Number of short fragments.
Runs	Number of fragments (that were too long to qualify as short events).
Collisions	Number of simultaneous node transmissions detected by this device.
Late Events	Number of frames where a collision occurred late in the transmission.
Data Rate Mismatches	Number of frames for which the data rate does not match the local frequency.
Broadcast Packets	Total number of broadcast packets detected.
Multicast Packets	Total number of multicast packets detected.
[Refresh]	Immediately refreshes statistics.
Refresh Mode Select	The scroll-down window includes options for: "autoRefresh" of the front panel every 10 seconds, or "manual" refresh by pressing the [Refresh] button.

**Values are counted from the time the Control Table entry was created.**

---

## MIB Browser

The MIB Browser menu allows access to various MIB group data and statistics. This guide provides only a summary of the MIBs supported by the Agent Module. All MIB group objects are as defined by RFC 1213 (MIB II), RFC 2108 (Multi-Segment Repeater MIB), and RFC 1643 (Ethernet-Like MIB). For further information on specific MIB entries, refer to the on-line help provided by the Web Agent.



Menu	Description
MIB II	Browse through MIB II group objects for detailed statistics, settings and configuration options.
Repeater MIB	Browse through Repeater MIB objects for segment, hub and port statistics.
Cabletron MIB	Cabletron's private MIB enables configuration of Community Names, Trap Managers and initiation of a TFTP download for software upgrades.

---

## RMON Browser

The RMON Browser enables access to the RMON data groups supported by the Agent Module. This guide only provides an outline of the menu items available. All Statistics, History, Alarm and Event group parameters are defined by RFC 1757 (RMON MIB). Note that the control table entries can only be set using SNMP-based network management software.



Menu	Description
Statistics	View the data for each control table entry in the Statistics group. For the selected entry, view numeric data or graphical pie charts for packet size distribution and packet errors.
History	View the History control table entries and the data collected for each entry. For the selected entry, view graphical displays of packet rates and utilization.
Alarm	View the control table entries for alarms.
Event	View the control table entries for events and the event log.

## Ethernet Statistics

The RMON Manager collects statistics that allow you to quickly determine how the network is performing. Select “Statistics” then “Statistics Entry” to display Ethernet statistics.

Refresh Time Interval:

**RMON Ethernet Statistics**

Statistics Index	Data Source	Drop Events	Octets	Packets	Broadcast Packets	Multicast Packets	CRC Alignment Errors	Undersize Packets	Oversize Packets	Fragments	Jobs
1	[1.3.6.1.2.1.2.2.1.1.4]	0	517429464	1281448	53865	7071	0	0	0	928	0
2	[1.3.6.1.2.1.2.2.1.1.5]	0	1806908	40639	53869	7071	0	0	0	0	0

Collisions	Packets 64 to 127 Octets	Packets 128 to 255 Octets	Packets 256 to 511 Octets	Packets 512 to 1023 Octets	Packets 1024 to 1518 Octets	Owner	Status
5	361777	583629	117075	36002	53741	274215	monitor valid (1)
0	8018	3981	17843	4968	52	476	monitor valid (1)

Item	Description
Statistics Index	Index for this item in the control table.
Data Source	MIB variable that is being monitored: 1.3.6.1.2.1.2.2.1.1.4 - 100 Mbps stack backplane 1.3.6.1.2.1.2.2.1.1.5 - 10 Mbps stack backplane 1.3.6.1.2.1.2.2.1.1.6 - Stack Unit 1 100 Mbps segment 1.3.6.1.2.1.2.2.1.1.7 - Stack Unit 1 10 Mbps segment ... 1.3.6.1.2.1.2.2.1.1.16 - Stack Unit 6 100 Mbps segment 1.3.6.1.2.1.2.2.1.1.17 - Stack Unit 6 10 Mbps segment
Drop Events	Number of events detected when packets were dropped (due to a lack of resources condition in the probe).
Octets	Total number of octets of data (including those in bad packets) received on the network (excluding framing bits but including FCS octets).
Packets	Displays the total count for all packets, broadcasts, multicasts, and dropped packets.
Broadcast Packets	Number of broadcast packets.
Multicast Packets	Number of multicast packets.
CRC Alignment Errors	Total number of packets with a CRC or alignment error.
Undersize Packets	Total number of undersize packets.
Oversize Packets	Total number of oversize packets.
Fragments	Total number of packet fragments.

---

Jabbers	Total number of jabber errors.
Collisions	Total number of packet collisions.
Packets 64 Octets	Number of packets less than 64 octets.
Packets 64 to 127 Octets	Number of packets between 64 and 127 octets.
Packets 128 to 255 Octets	Number of packets between 128 and 255 octets.
Packets 256 to 511 Octets	Number of packets between 256 and 511 octets.
Packets 512 to 1023 Octets	Number of packets between 512 and 1023 octets.
Packets 1024 to 1518 Octets	Number of packets between 1024 and 1518 octets.
Owner	Person who added this entry to the control table.
Status	Indicates if this control entry has been set to valid or invalid.
[Refresh]	Immediately refreshes the status.
Refresh Mode Select	The scroll-down window includes options for: "autoRefresh" of the screen every 10 seconds, or "manual" refresh by pressing the [Refresh] button.

---

**Values are counted from the time the Control Table entry was created.**

---

## Packets Pie Chart

Select “Statistics” then “Packets Pie Chart” to display the graphic representation of packet size distribution.

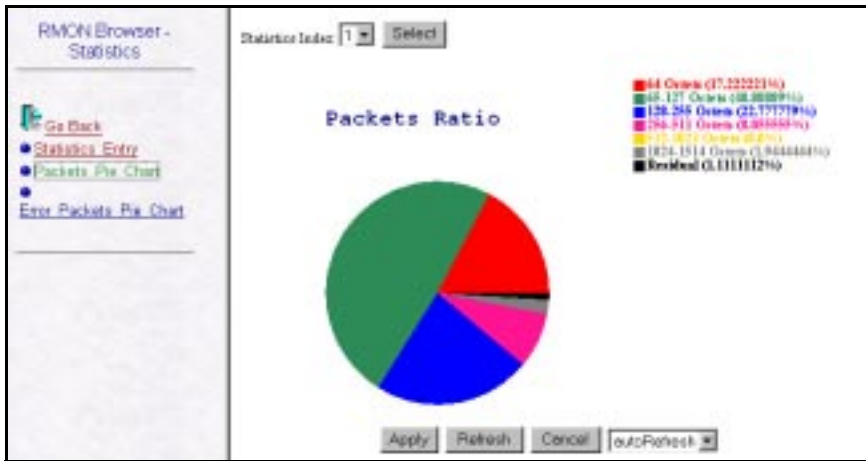

Item	Description
Packets	
64 Octets	Number of packets less than 64 octets.
64 to 127 Octets	Number of packets between 64 and 127 octets.
128 to 255 Octets	Number of packets between 128 and 255 octets.
256 to 511 Octets	Number of packets between 256 and 511 octets.
512 to 1023 Octets	Number of packets between 512 and 1023 octets.
1024 to 1518 Octets	Number of packets between 1024 and 1518 octets.
Residual	Number of packets greater than 1518 octets.
[Refresh]	Immediately refreshes the status.
Refresh Mode Select	The scroll-down window includes options for: “autoRefresh” of the screen every 10 seconds, or “manual” refresh by pressing the [Refresh] button.
<b>Values are counted from the time the Control Table entry was created.</b>	

## Error Packets Ratio

Select “Statistics” then “Error Packets Ratio” to display the graphic representation of the distribution of error types.

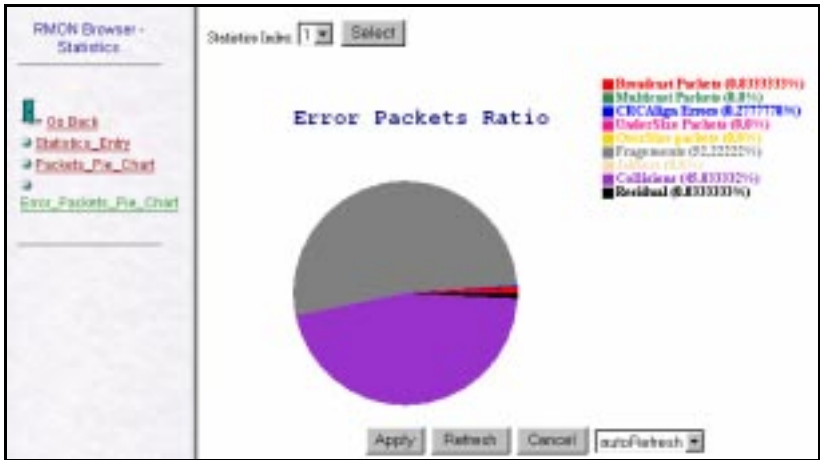

Item	Description
Broadcast Packets	Percentage of broadcast packet errors.
Multicast Packets	Percentage of multicast packets errors.
CRC Align Errors	Percentage of CRC and alignment errors.
Undersize Packets	Percentage of undersize packets.
Oversize Packets	Percentage of oversize packets.
Fragments	Percentage of fragments.
Jabbers	Percentage of jabbers.
Collisions	Percentage of collisions.
Residuals	Percentage of remaining error types.
[Refresh]	Immediately refreshes the status.
Refresh Mode Select	The scroll-down window includes options for: “autoRefresh” of the screen every 10 seconds, or “manual” refresh by pressing the [Refresh] button.

**Values are counted from the time the Control Table entry was created.**

## History Control Entry

RMON can be used to create a record of network utilization, packet types, errors and collisions. You need a historical record of activity to track down intermittent problems. Historical data can also be used to establish normal baseline activity, which may reveal problems associated with high traffic levels, broadcast storms, or other unusual events. Historical information can also be used to predict network growth and plan for expansion before your network becomes too overloaded. Select "History" then "History Control Entry" to display the collection items defined in the history control table.

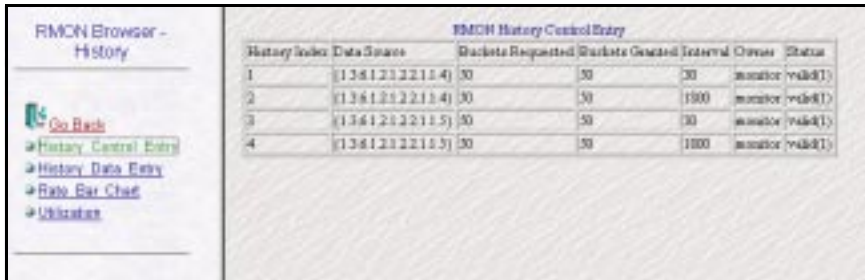

The screenshot shows a web-based interface for RMON. On the left is a navigation menu with options: Go Back, History Control Entry (highlighted), History Data Entry, Rate Bar Chart, and Utilization. The main area displays a table titled "RMON History Control Entry" with the following data:

History Index	Data Source	Buckets Requested	Buckets Granted	Interval	Owner	Status
1	(1.3.6.1.2.1.2.2.1.1.4)	50	50	30	monitor	valid(1)
2	(1.3.6.1.2.1.2.2.1.1.4)	50	50	1000	monitor	valid(1)
3	(1.3.6.1.2.1.2.2.1.1.5)	50	50	30	monitor	valid(1)
4	(1.3.6.1.2.1.2.2.1.1.5)	50	50	1000	monitor	valid(1)

Item	Description
History Index	An index that uniquely identifies an entry in the History Control table. Each such entry defines a set of samples at a particular interval for an interface on the device.
Data Source	MIB variable that is being monitored: 1.3.6.1.2.1.2.2.1.1.1 - Agent board 100 Mbps interface 1.3.6.1.2.1.2.2.1.1.2 - Agent board 10 Mbps interface 1.3.6.1.2.1.2.2.1.1.3 - Serial port for out-of-band connection 1.3.6.1.2.1.2.2.1.1.4 - 100 Mbps stack backplane 1.3.6.1.2.1.2.2.1.1.5 - 10 Mbps stack backplane 1.3.6.1.2.1.2.2.1.1.6 - Stack Unit 1 100 Mbps segment 1.3.6.1.2.1.2.2.1.1.7 - Stack Unit 1 10 Mbps segment ... 1.3.6.1.2.1.2.2.1.1.16 - Stack Unit 6 100 Mbps segment 1.3.6.1.2.1.2.2.1.1.17 - Stack Unit 6 10 Mbps segment
Buckets Requested	Requested number of discrete time intervals over which data is to be saved in the part of the media-specific table associated with this entry.
Buckets Granted	Number of discrete sampling intervals over which data shall actually be saved in the part of the media-specific table associated with this entry.
Interval	Interval in seconds over which the data is sampled for each bucket in the part of the media-specific table associated with this entry.
Owner	Person who added this entry to the control table.
Status	Indicates if this control entry has been set to valid or invalid.



## History Data Entry

Select "History" then "History Data Entry" to display the data recorded for items in the history control table.

History Index	Sample Index	Interval Start	Drop Events	Octets	Packets	Broadcast Packets	Multicast Packets	CRC Alignment Errors	Undersize Packets	Oversize Packets	Fragments	Jitters	Collisions	Utilization
1	271	04:29:00.236000_00_23:59:00.00	0	97138	698	573	87	0	0	0	0	0	0	2

Item	Description
History Index	An index that uniquely identifies an entry in the History Control table. Each such entry defines a set of samples at a particular interval for an interface on the device.  History Indexes can include: 100 Mbps segment with samples taken every 30 seconds, 100 Mbps segment with samples taken every 1800 seconds, 10 Mbps segment with samples taken every 30 seconds, or 10 Mbps segment with samples taken every 1800 seconds.
Refresh Time Interval	Interval at which data displayed to the screen is refreshed.
Sample Index	An index that uniquely identifies the particular sample this entry represents among all samples associated with the same history control entry. This index starts at 1 and increases by one as each new sample is taken.
Interval Start	Value of sysUpTime at the start of the interval over which this sample was measured.
Drop Events	Total number of events in which packets were dropped by the probe due to lack of resources during this sampling interval. This number is not necessarily the number of packets dropped, it is just the number of times this condition has been detected.
Octets	Total number of octets of data (including those in bad packets) received on the network (excluding framing bits but including FCS octets).
Packets	Number of packets (including bad packets) received during this sampling interval.
Broadcast Packets	Number of good packets received during this sampling interval that were directed to the broadcast address.
Multicast Packets	Number of good packets received during this sampling interval that were directed to a multicast address. This number does not include packets addressed to the broadcast address.

---

CRC Alignment Errors	Number of packets received during this sampling interval that had a length (excluding framing bits but including FCS octets) between 64 and 1518 octets, inclusive, but had either a bad Frame Check Sequence (FCS) with an integral number of octets (FCS Error) or a bad FCS with a non-integral number of octets (Alignment Error).
Undersize Packets	Number of packets received during this sampling interval that were less than 64 octets long (excluding framing bits but including FCS octets) but were otherwise well formed.
Oversize Packets	Number of packets received during this sampling interval that were longer than 1518 octets (excluding framing bits but including FCS octets) but were otherwise well formed.
Fragments	Total number of packets received during this sampling interval that were less than 64 octets in length (excluding framing bits but including FCS octets), had either a bad Frame Check Sequence (FCS) with an integral number of octets (FCS Error) or a bad FCS with a non-integral number of octets (Alignment Error). Note that it is entirely normal for etherHistoryFragments to increment. This is because it counts both runts (which are normal occurrences due to collisions) and noise hits.
Jabbers	Number of packets received during this sampling interval that were longer than 1518 octets (excluding framing bits but including FCS octets), and had either a bad Frame Check Sequence (FCS) with an integral number of octets (FCS Error) or a bad FCS with a non-integral number of octets (Alignment Error).
Collisions	Best estimate of the total number of collisions on this Ethernet segment during this sampling interval.
Utilization	Best estimate of the mean physical layer network utilization on this interface during this sampling interval, in hundredths of a percent.
[Refresh]	Immediately refreshes the status.
Refresh Mode Select	The scroll-down window includes options for: "autoRefresh" of the screen every 10 seconds, or "manual" refresh by pressing the [Refresh] button.

---

**Values are counted from the time the Control Table entry was created.**

---

## Rate Bar Chart

Select “History” then “Rate Bar Chart” to display the recorded rate of packets, broadcasts, multicasts and collisions collected for the selected segment. The scale for the graphic display is automatically adjusted to present the best view possible. (However, the smallest increment on the vertical axis is limited to 0.05.).

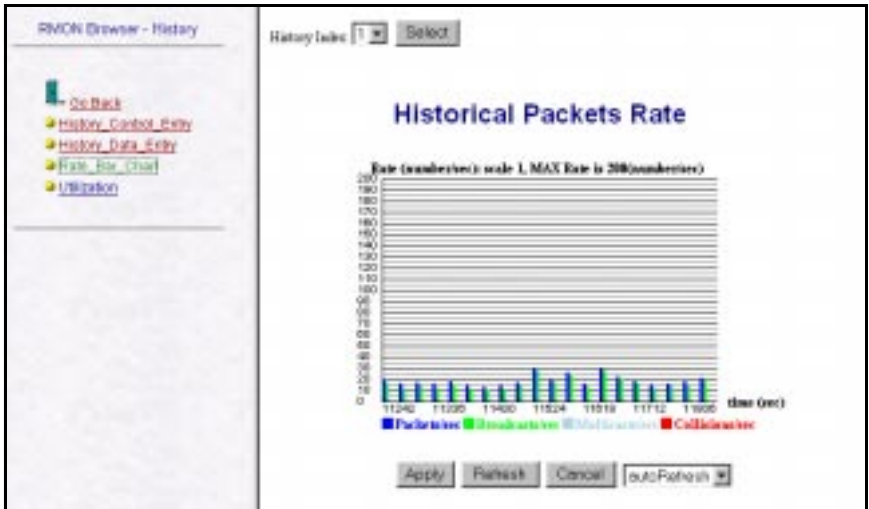

Item	Description
History Index	Selections include: (1) 100 Mbps segment with count incremented every 30 seconds, (2) 100 Mbps segment with count incremented every 1800 seconds, (3) 10 Mbps segment with count incremented every 30 seconds, (4) 10 Mbps segment with count incremented every 1800 seconds.
Packets/sec	Rate at which packets (including bad packets) were received during this sampling interval.
Broadcasts/sec	Rate at which packets were received during this sampling interval that were directed to the broadcast address.
Multicasts/sec	Rate at which packets were received during this sampling interval that were directed to a multicast address. This number does not include packets addressed to the broadcast address.
Collisions/sec	Rate of collisions on this Ethernet segment during this sampling interval.
[Refresh]	Immediately refreshes the status.
Refresh Mode Select	The scroll-down window includes options for: “autoRefresh” of the screen every 10 seconds, or “manual” refresh by pressing the [Refresh] button.

**Values are counted from the time the Control Table entry was created.**

---

## Utilization

Select “History” then “Utilization” to display the percentage of bandwidth utilized over the sample period.

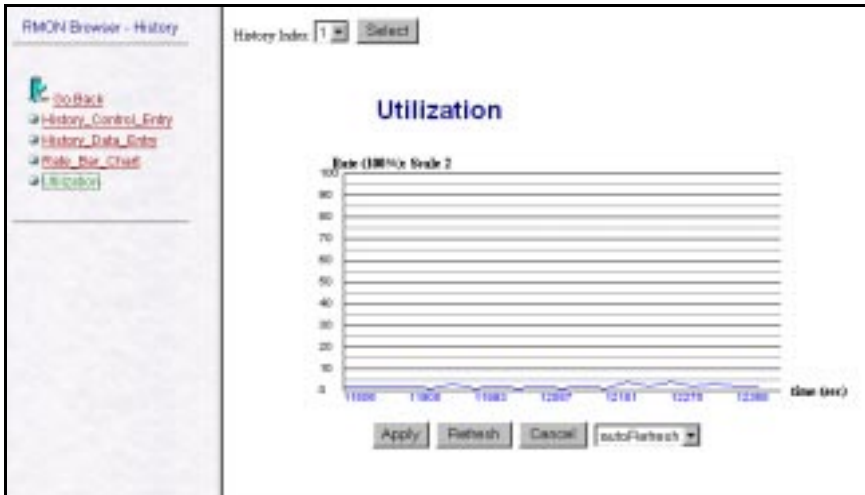

Item	Description
Utilization	Displays the bandwidth utilization for the selected segment.  History Index selections include: (1) 100 Mbps segment with utilization incremented every 30 seconds, (2) 100 Mbps segment with utilization incremented every 1800 seconds, (3) 10 Mbps segment with utilization incremented every 30 seconds, (4) 10 Mbps segment with packet count incremented every 1800 seconds.
[Refresh]	Immediately refreshes the status.
Refresh Mode Select	The scroll-down window includes options for: “autoRefresh” of the screen every 10 seconds, or “manual” refresh by pressing the [Refresh] button.

---

**Values are counted from the time the Control Table entry was created.**

---

---

## Alarm

The Alarm and Event Groups allow you to record important events or immediately respond to critical network problems. The Alarm and Event Control Tables are used together to define specific criteria that will generate response events. Remember that the Web Agent can only display control entries. To define a specific entry, you must use third-party network management software. Select "Alarm" then "Alarm Entry" to display the items listed in the control table for monitoring.

Alarm Index	Interval	Variable	Sample Type	Value	Startup Alarm	Rising Threshold	Falling Threshold	Rising Event Index	Falling Event Index	Owner	Status
3264	10	(1.3.6.1.2.1.16.1.1.4.1)	deltaValue (2)	33963	risingOrFallingAlarm (3)	1000	1	1	1	nms	valid (1)

Item	Description
Alarm Index	An index that uniquely identifies an entry in the alarm table. Each such entry defines a diagnostic sample at a particular interval for an object on the device.
Interval	Interval in seconds over which the data is sampled and compared with the rising and falling thresholds.
Variable	Object identifier of the particular variable to be sampled.
Sample Type	Method of sampling the selected variable and calculating the value to be compared against the thresholds. If the value of this object is absoluteValue(1), the value of the selected variable will be compared directly with the thresholds at the end of the sampling interval. If the value of this object is deltaValue(2), the value of the selected variable at the last sample will be subtracted from the current value, and the difference compared with the thresholds.
Value	Value of the statistic during the last sampling period.
Startup Alarm	If the first sample (after this entry becomes valid) is greater than or equal to the risingThreshold AND alarmStartupAlarm is equal to risingAlarm(1) or risingOrFallingAlarm(3), then a single rising alarm will be generated. If the first sample (after this entry becomes valid) is less than or equal to the fallingThreshold AND alarmStartupAlarm is equal to fallingAlarm(2) or risingOrFallingAlarm(3), then a single falling alarm will be generated.
Rising Threshold	When the current sampled value is greater than or equal to this threshold, and the value at the last sampling interval was less than this threshold, a single event will be generated. A single event will also be generated if the first sample after this entry becomes valid is greater than or equal to this threshold and the associated alarmStartupAlarm is equal to risingAlarm(1) or risingOrFallingAlarm(3). After a rising event is generated, another such event will not be generated until the sampled value falls below this threshold and reaches the alarmFallingThreshold.

---

Falling Threshold	When the current sampled value is less than or equal to this threshold, and the value at the last sampling interval was greater than this threshold, a single event will be generated. A single event will also be generated if the first sample after this entry becomes valid is less than or equal to this threshold and the associated alarmStartupAlarm is equal to fallingAlarm(2) or risingOrFallingAlarm(3). After a falling event is generated, another such event will not be generated until the sampled value rises above this threshold and reaches the alarmRisingThreshold.
Rising Event Index	Index of the eventEntry that is used when a rising threshold is crossed. If this value is zero, no associated event will be generated.
Falling Event Index	Index of the eventEntry that is used when a falling threshold is crossed. If this value is zero, no associated event will be generated.
Owner	Entity that configured this entry and is therefore using the resources assigned to it.
Status	Status of this alarm entry.

---

---

## Event Table

Select “Event” then “Event Table” to display the action to take when an alarm is triggered. The response to an alarm can include logging the alarm in a database or sending a message to a trap manager.



Item	Description
Event Index	An index that uniquely identifies an entry in the event table. Each such entry defines one event that is to be generated when the appropriate conditions occur.
Description	A comment describing this event entry.
Type	Type of notification that the probe will make about this event.
Community	If an SNMP trap is to be sent, it will be sent to the SNMP community specified by this string.
Last Time Sent	Value of sysUpTime at the time this event entry last generated an event. If this entry has not generated any events, this value will be zero.
Owner	Entity that configured this entry and is therefore using the resources assigned to it.
Status	Status of this event entry.

## Log Table

Select “Event” then “Log Table” to display each time an event was triggered. Note that there are no display windows associated with the Alarm and Event groups other than the control and log tables.

The screenshot shows the 'RMCH Browser - Event' window. On the left is a sidebar with 'Go Back', 'Event Table', and 'Log Table' buttons. The main area has a 'Event Index' dropdown set to '1' and a 'Select' button. Below that is a 'Refresh Time Interval' input field with '10' and a 'Go' button. The title 'RMCH Log Entry' is centered above a table with the following content:

Event Index	Log Index	Time	Description
0	1	1361231611.141	(delta = 5842, Firing Threshold = 100, interval = 10 (alarmIndex: 115) total octets)

At the bottom are buttons for 'Apply', 'Refresh', 'Cancel', and 'autoRefresh'.

Item	Description
Event Index	Event entry that generated this log entry.
Refresh Time Interval	Interval at which data displayed to the screen is refreshed.
Log Index	An index that uniquely identifies an entry in the log table amongst those generated by the same eventEntries.
Time	Value of sysUpTime when this log entry was created.
Description	An implementation dependent description of the event that activated this log entry.
[Refresh]	Immediately refreshes the status.
Refresh Mode Select	The scroll-down window includes options for: “autoRefresh” of the screen every 10 seconds, or “manual” refresh by pressing the [Refresh] button.

**Values are counted from the time the Control Table entry was created.**



---

## 6. SNMP MANAGEMENT

---

### The SNMP Protocol

SNMP (Simple Network Management Protocol) is a communication protocol designed specifically for the purpose of managing devices or other elements on a network. Network equipment commonly managed with SNMP includes hubs, switches, routers, and host computers. SNMP is typically used to configure these types of devices for proper operation in their network environment, as well as to monitor them to evaluate their performance and detect potential problems.

Managed entities supporting SNMP typically contain software, which runs locally on the device and is referred to as an agent. In Figure 6-1, software in an ELH100-24TX hub functions as an agent, monitoring and controlling the functionality of the hub.

**Figure 6-1. ELH100-12/24TX Hubs Managed by an SNMP Management Workstation**

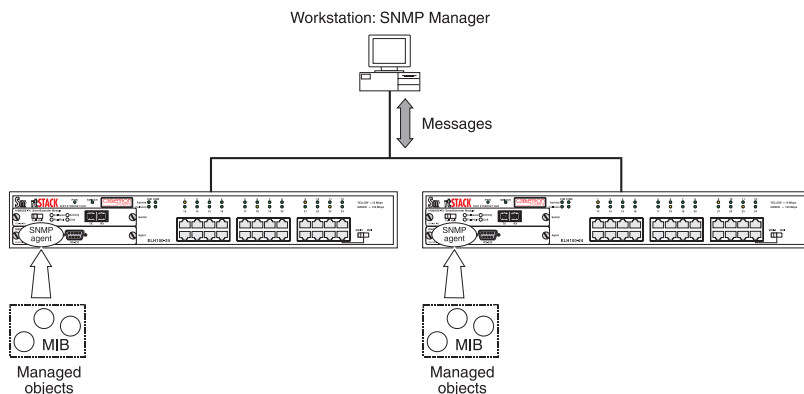

A defined set of variables, referred to as managed objects, is maintained by the agent and used to manage the device. These objects are defined in a Management Information Base (MIB) which allows for a standard presentation of the information controlled by the agent over the network.

The software used to access the information maintained by the SNMP agents across a network is referred to as the SNMP Manager, and typically runs on a workstation.

The SNMP manager software uses a MIB specification, equivalent to that which the agent maintains, to read and write objects controlled by the agent for purposes of configuring and monitoring the device. SNMP defines the format of the MIB specifications and the protocol used to access this information.

---

There are three main operations defined in SNMP:

- GET operations read information from the managed device, such as those used to obtain status or statistical data.
- SET operations change a functional parameter on the device, such as those used to configure Port Speed or to initiate a software download. GET and SET operations are initiated only by the manager software, and result in a response by the agent.
- TRAP operations allow the agent to send an unsolicited message to the manager. This operation is typically used as an alert of a potential problem or a change of status with the device. The Trap Destination parameter in the SNMP Configuration Menu is used to configure the IP addresses of the SNMP Manager to which ELH100-12/24TX trap messages are sent.

## MIB Objects

A number of standard MIB specifications have been defined for managing network equipment. SNMP compliant devices typically support one or more standard MIBs defined by the Internet Engineering Task Force (IETF), in the form of Request for Comments (RFC) documents.

These MIBs provide a common method of managing devices, such as hubs and switches, and network interfaces, such as Ethernet and token ring. The primary standard MIB, referred to as MIB-II, provides an overall view of the managed agent and must be supported, at least in part, by all SNMP agents. In addition, proprietary MIB extensions are defined by commercial vendors for managing device-specific functions of their products.

The ELH100-12/24TX hub supports four standard MIBs:

- RFC 1213 - Management Information Base for Network Management of TCP/IP based Internets (MIB-II)
- RFC 2108 - Multi-segment Repeater Management Information Base
- RFC 1643 - Ethernet-like Management Information Base
- RFC 1757 - Remote Network Monitoring Management Information Base

The ELH100-12/24TX hub also supports Cabletron proprietary MIB extensions.

### **RFC 1213 (MIB-II)**

RFC 1213 provides management of system-level parameters, including TCP/IP protocol-related statistics, IP addressing, and interface statistics for each hub port. MIB-II is the standard MIB defined by RFC 1213. All agent devices operating SNMP are required to support at least part of MIB-II.

---

This MIB reports information about the protocols and network interfaces supported on the agent itself, as well as other general information. The MIB is divided into a number of groups, each of which corresponds to a specific protocol or set of information. Some groups are defined in other RFC documents.

The groups specifically defined in RFC 1213 and supported by the ELH100-12/24TX hub system software are as follows:

- System – General information about the agent system
- Interfaces – Information about the network interfaces of the system
- Address Translation – Interface address information, both MAC level and network (IP) level
- IP – Statistics and information related to the IP protocol
- ICMP – Statistics and information related to the ICMP protocol
- TCP – Statistics and information related to the TCP protocol
- UDP – Statistics and information related to the UDP protocol
- Transmission – Statistics and information related to the physical network medium to which the system interfaces (e.g. Ethernet, token ring, etc.).
- SNMP – Statistics and information related to the SNMP protocol

### **RFC 2108 (Multi-segment Repeater)**

RFC 2108 provides management and monitoring for multi-segment repeaters. This group provides a set of managed objects for devices (repeaters, MAUs, interfaces) that conform to the IEEE 802.3 standard for Ethernet.

### **RFC 1643 (Ethernet-like)**

RFC 1643 provides management and monitoring for the Ethernet-specific aspects of each segment on the hub. Instances of these object types represent attributes of an interface to an Ethernet-like communications medium.

### **RFC 1757 (RMON MIB)**

RFC 1757 is a group defined under MIB-II. This MIB provides management for the RMON aspects of the hub. The ELH100-12/24TX hub supports four of the nine groups of RMON defined for Ethernet networks on a per segment basis. For further information, see the subsection "RMON" in Chapter 1 or "RMON Browser" in Chapter 5.

### **Cabletron Proprietary MIB Extensions**

Areas of ELH100-12/24TX hub functionality not covered by the standard RFC MIBs are specified in the Cabletron private MIB. This MIB definition is specified separately from MIB-II. Areas covered in this MIB include various system, hub, and port level information.

---

## Compiling MIB Extensions: Cabletron Website

The MIBs supported by the ELH100-12/24TX hub must be compiled into the SNMP network management platform before the hub can be managed. The supported MIBs are available using Cabletron's website at:

*<http://www.cabletron.com>*

The four standard MIB specifications listed above with which the ELH100-12/24TX hub is compliant are generally available with the SNMP management platform.

---

# APPENDIX A. TECHNICAL SPECIFICATIONS

---

## General

### Standards Compliance

IEEE 802.2 Local Area Networks, Logical Link Control (LLC)

IEEE 802.3 CSMA/CD 9 (ISO/IEC 8802-3)

IEEE 802.3i 10Base-T (ISO/IEC 8802-3, clause 14)

IEEE 802.3u 100Base-TX (ISO/IEC 8802-3, clause 25)

IEEE 802.3u 100Base-FX (ISO/IEC 8802-3, clause 26)

EIA RS-232C (DTE-to-DCE)

EIA RS-310C (19-inch rackmount)

### Certification

Emissions: FCC Part 15, Subpart B, Class A; EN55022 (CISPR 22), Class A; VCCI Class A

Safety: CSA/NRTL (C22.2.950,UL1950); IEC 950 (TUV)

CE Directives: 89/336/EEC; 93/68/EEC; 73/23/EEC

### Data Rate

10 Mbps Manchester encoded, 100 Mbps 4B/5B encoded.

### Environmental Specifications

Operating temperature: 32° to 104° F (0° C to 40° C)

Operating humidity: 5 to 95% relative, non-condensing

Storage temperature: -40° to 158°F (-40° C to 70° C)

Storage humidity: 5 to 95% relative, non-condensing

---

## Electrical Specifications

Input voltage: 100-240 VAC

Input frequency: 50-60 Hz

Maximum power consumption: 50 VA

## Physical

Height: 2.5 in. (6.3 cm)

Length: 7.9 in. (20 cm)

Width: 17.3 in. (44 cm mountable in a standard 19 in. rack)

Weight: 9.92 lb. (4.5 kg)

---

## Port Specifications

### Console Port

Table A-1 shows the console port pin assignments.

**Table A-1. RS-232 Console Port Pin Assignments**

Pin	Signal Name
1	DCD
2	RXD
3	TXD
4	DTR
5	Ground
6	DSR
7	RTS
8	CTS
9	RI

### 10Base-T and 100Base-TX Ports

Table A-2 shows the 10Base-T/100Base-TX pinouts. These ports are wired MDI-X. All undefined pins are not used.

**Table A-2. 10Base-T/100Base-TX Pinouts**

Pin	MDI-X Signal Name
1	RD+
2	RD-
3	TD+
6	TD-

---

## MDI/MDI-X Crossover Cable Wiring

Figure A-1 shows the wiring scheme for implementing a crossover cable if needed for connection to the hub's 10Base-T or 100Base-TX ports. Such a cable may be required when connecting the hub to another hub or a switch device.

**Figure A-1. External Crossover Cable Wiring**

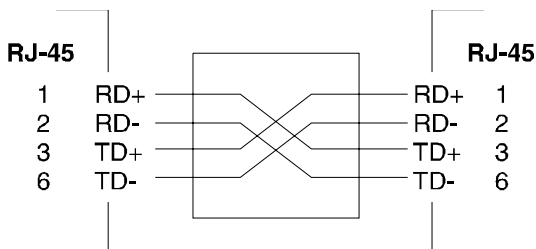

## Power Cord Set Requirements

The wide-range input feature of the ELH100-12/24TX Ethernet hub permits it to operate from any line voltage between 100 and 240 VAC.

The power cord set (appliance coupler, flexible cord, and wall plug) you received with the hub meets the requirements for use in the country where you purchased the hub.

Power cord sets for use in other countries must meet the requirements of the country where you use the hub. For more information on power cord set requirements, contact your Cabletron System Support Representative.

### General Requirements

The requirements listed below are applicable to all countries:

- The length of the power cord set must be at least 5.00 feet (1.5 m) and a maximum of 6.56 feet (2.0 m).
- All power cord sets must be approved by an acceptable accredited agency responsible for evaluation in the country where the power cord set will be used.
- The power cord set must have a minimum current capacity of 10A and a nominal voltage rating of 125 or 250 VAC, as required by each country's power system.
- The appliance coupler must meet the mechanical configuration of an EN 60 320/IEC 320 Standard Sheet C13 connector for mating with appliance inlet on the hub.



---

## Country-Specific Requirements

Table A-3 lists the power cord set requirements by country and identifies the accredited agency within that country.

**Table A-3. Power Cord Set Requirements by Country**

Country	Accredited Agency	See Notes *
Australia	EANSW	1
Austria	OVE	1
Belgium	CEBC	1
Canada	CSA	2
Denmark	DEMKO	1
Finland	FIMKO	1
France	UTE	1
Germany	VDE	1
Italy	IMQ	1
Japan	JIS	3
Netherlands	KEMA	1
Norway	NEMKO	1
Sweden	SEMKO	1
Switzerland	SEV	1
United Kingdom	BSI	1
United States	UL	2

**\* The note column includes a number. Associate this number with the corresponding notes listed after the table to obtain specific power standards and requirements.**

### Note 1

Flexible cord must be <HAR> Type HO5VV-F or HO3VV-F, 3-conductor, 1.0 mm<sup>2</sup>, or 0.75 mm<sup>2</sup> conductor size. Power cord set fittings (appliance coupler and wall plug) must bear the certification mark of the agency responsible for evaluation in the country where it will be used.

---

### Note 2

Flexible cord must be Type SV, SJ, SPT or equivalent, No. 18 AWG, 3-conductor. Wall plug must be a two-pole grounding type with a NEMA 5-15P (15A, 125V) or NEMA 6-15P (15A 250V) configuration.

### Note 3

Appliance coupler, flexible cord, and wall plug must bear a "T" mark and registration number in accordance with the Japanese Dentori Law.

Flexible cord must be Type VCT or VCTF, 3-conductor, 0.75mm<sup>2</sup> conductor size. Wall plug must be a two-pole grounding type with a Japanese Industrial Standard C8303 (15A, 125V) configuration.

---

## APPENDIX B. ACRONYMS & ABBREVIATIONS

---

<b>Term</b>	<b>Definition</b>
10Base-T	10 Mbps twisted-pair Ethernet
100Base-TX	100 Mbps twisted-pair Fast Ethernet
100Base-FX	100 Mbps fiber option Fast Ethernet
ANSI	American National Standards Institute
BootP	Bootstrap Protocol
CAT5	Category 5
CRC	Cyclic Redundancy Check
CSMA/CD	Carrier Sense Multiple Access/Collision Detection
DCE	Data Communications Equipment (modem)
DSR	Data Send Ready
DTE	Data Terminal Equipment
DTR	Data Terminal Ready
FCS	Frame Check Sequence
ICMP	Internet Control Message Protocol
IEEE	Institute of Electrical and Electronics Engineers
IP	Internet Protocol
LAN	Local Area Network
MAC	Media Access Control
LED	Light Emitting Diode
MDI	Media Device Interface
MIB	Management Information Base
RFC	Request for Comment
RMON	Remote Monitoring
RXD	Receive Data
SNMP	Simple Network Management Protocol
TCP/IP	Transmission Control Protocol/Internet Protocol
TFTP	Trivial File Transfer Protocol
TXD	Transmit Data
UTP	Unshielded Twisted Pair

---



---

# INDEX

---

100Base-FX  
  fiber ports, 25  
  module defined, 5  
100M LED, defined, 6  
10Base-T/100Base-TX  
  module defined, 5  
  pinouts, 93  
  ports, 24  
802.2, 91  
802.3, 24, 91  
802.3i, 91  
802.3u, 91

## A

Activity LED, defined, 6  
Agent Configuration  
  Web interface, 66  
Agent Module  
  description, 21  
architecture  
  dual-speed hub, 2  
  internal switch, 3  
Auto-negotiation, 9

## B

Backup Port Control Menu, 43  
bandwidth utilization, 82  
BootP, 10  
BootP/DHCP  
  configuring, 59

## C

cable, RS-232, 19  
certification, 91  
Collision LED, defined, 6  
communication settings, 20  
community names, 55  
Configuration and Management  
  Interfaces, 8  
configuring the hub  
  common tasks, 53

connecting  
  network cables, 23  
  to the stack's backplane, 16  
Console Configuration Menu, 47  
console port, 8, 19  
  connecting to, 19  
  pin assignments, 93  
crossover cable, 24

## D

Data Rate, 91  
DB-9 connector, 8  
Default Gateway, setting, 58  
downloading  
  software upgrade, 7, 44, 45, 56, 57  
  via TFTP, 57  
  via the serial port, 56  
DTE connection, 19  
Dual-Speed Architecture, 7

## E

Electrical Specifications, 92  
Environmental Specifications, 91  
Error Packets Ratio, 77

## F

factory defaults, 28  
fiber interface, 23  
front panel, 4  
  components, 4  
  Web interface, 65  
full duplex mode, 10  
Full/Half LED, defined, 6

## H

History Control Entry, 78  
History Data Entry, 79  
Hub Backplane  
  Web interface, 68  
Hub Configuration  
  Menu, 38  
  Web interface, 67  
hub statistics, 56  
  screen, 48

- 
- I**
- in-band
    - configuration, 8
    - connection, 20
  - inspecting your shipment, 13
  - installing an optional module, 17
  - IP address, assigning, 54
- L**
- LED indicators, 3, 4, 6
  - Link LED, defined, 6
  - logout, 32
- M**
- Main Menu, 27, 30
    - Web interface, 62
  - MDI, 24
  - MDI/MDI-X Crossover Cable Wiring, 94
  - MDI-X, 24
  - menu hierarchy, 29
  - MIB, 87, 88
    - compiling extensions, 90
    - Ethernet-like, 89
    - Multi-segment, 89
    - Proprietary, 89
    - RMON, 89
  - MIB Browser
    - Web interface, 72
  - MIB-II, 88
  - modem connection, configuring, 20
  - Module Port Configuration Menu, 42
  - mounting ears, 15
  - mounting the switch
    - rack, 15
- N**
- network
    - configuration status, 54
    - management, 3
  - non-volatile parameter storage, 8
- O**
- optional modules, 2, 5
  - out-of-band configuration, 8
- P**
- Packets Pie Chart, 76
  - password
    - menu, 46
    - protection, 8, 53
  - Physical Specifications, 92
  - Port Backup, Web interface, 70
  - Port Configuration
    - Menu, 41
    - Web interface, 69
  - port LEDs, 4
    - defined, 4, 6
  - port operation
    - configuring, 58
  - Port Specifications, 93
  - Port Statistics Screen, 50
  - ports, types, 2
  - power connector, defined, 7
  - power cord, 22
    - country-specific requirements, 95
    - set requirements, 94
  - power LED, 4
    - defined, 4
  - power, source, 13
  - powering the hub, 22
  - power-up tests, 22
- R**
- Rate Bar Chart, 81
  - rear panel, 7
  - redundant power connector, defined, 7
  - Remote Monitoring, 9
  - reset, 30, 32
  - resetting the hub, 32
  - RJ-45
    - connectors, 24
    - ports, 4
    - ports defined, 4
  - RMON, 9
    - Alarm, 73, 83
    - Error Packets Ratio, 77
    - Event, 73
    - Event Table, 85
    - History, 73
    - History Control Entry, 78
    - History Data Entry, 79
    - Log Table, 86
    - Packets Pie Chart, 76
    - Rate Bar Chart, 81
    - Statistics, 73, 74
    - Utilization, 82
  - RMON Browser
    - Web interface, 73
  - router, 87
  - RS-232 connection, 8

---

## S

- screen timeout, 54
- segment LEDs, 4
  - defined, 4
- Serial port, 8
- site requirements, 13
- SNMP, 8, 36, 55, 87, 88, 90
  - Communities, 36
  - Configuration Menu, 35
  - setting access, 55
  - Trap Destinations, 37
- SNMP-based network manager, 8
- Spanning Tree, 58
- stack cable, 16
- Stack Connectors, defined, 7
- Standards Compliance, IEEE, 91
- switch LED, 4
  - defined, 4
- Switch Module Statistics
  - Web interface, 71
- Switch/Media Module
  - how to use, 18
- System Configuration Menu, 33
- System Information
  - Menu, 31
  - Web interface, 63

## T

- TCP/IP protocol, 8

- Telnet, 8, 27
  - connecting, 55
  - connection, 20
- terminal, 8, 19
- TFTP download, 57
  - menu, 43

## U

- Unshielded Twisted Pair (UTP), 23
  - user access, 28
- User Password Menu, 46

## V

- ventilation, 13
- VT100, 8

## W

- Web browser, 8
- Web-based
  - management, 61
  - network manager, 8

## X

- XMODEM Download Menu, 45





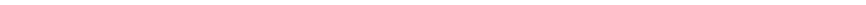



## Free Manuals Download Website

<http://myh66.com>

<http://usermanuals.us>

<http://www.somanuals.com>

<http://www.4manuals.cc>

<http://www.manual-lib.com>

<http://www.404manual.com>

<http://www.luxmanual.com>

<http://aubethermostatmanual.com>

Golf course search by state

<http://golfingnear.com>

Email search by domain

<http://emailbydomain.com>

Auto manuals search

<http://auto.somanuals.com>

TV manuals search

<http://tv.somanuals.com>