

brother®

USER'S GUIDE

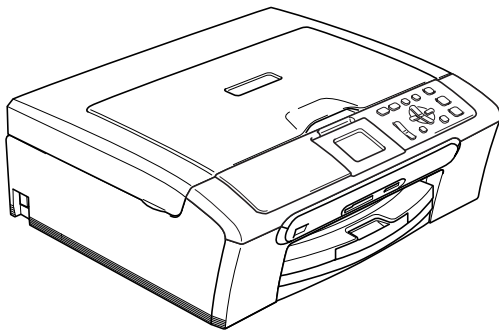

DCP-330C
DCP-540CN

If you need to call Customer Service

Please complete the following information for future reference:

Model Number: DCP-330C and DCP-540CN
(Circle your model number)

Serial Number: ¹ _____

Date of Purchase: _____

Place of Purchase: _____

¹ The serial number is on the back of the unit. Retain this User's Guide with your sales receipt as a permanent record of your purchase, in the event of theft, fire or warranty service.

Register your product on-line at

<http://www.brother.com/registration/>

By registering your product with Brother, you will be recorded as the original owner of the product. Your registration with Brother:

- may serve as confirmation of the purchase date of your product should you lose your receipt;
- may support an insurance claim by you in the event of product loss covered by insurance; and,
- will help us notify you of enhancements to your product and special offers.

The most convenient and efficient way to register your new product is on-line at <http://www.brother.com/registration/>

© 2006 Brother Industries, Ltd.

Brother numbers

IMPORTANT

For technical help, you must call the country where you bought the machine. Calls must be made **from within** that country.

Register your product

By registering your product with Brother International Corporation, you will be recorded as the original owner of the product. Your registration with Brother:

- may serve as confirmation of the purchase date of your product should you lose your receipt;
- may support an insurance claim by you in the event of product loss covered by insurance; and,
- will help us notify you of enhancements to your product and special offers.

Please complete and fax the Brother Warranty Registration And Test Sheet or, for your convenience and most efficient way to register your new product, register on-line at

<http://www.brother.com/registration/>

FAQs (frequently asked questions)

The Brother Solutions Center is our one-stop resource for all your Digital Copier needs. You can download the latest software documents and utilities, read FAQs and troubleshooting tips, and learn how to get the most from your Brother product.

<http://solutions.brother.com>



Note

- You can check here for Brother driver updates.
- To keep your machine performance up to date, check here for the latest firmware upgrade (for Windows® only).

For Customer Service

In USA:	1-800-284-4329 (voice)
	1-901-379-1215 (fax)
	1-800-284-3238 (TTY service for the hearing-impaired)
In Canada:	1-877-BROTHER (voice)
	(514) 685-4898 (fax)

Service Center Locator (USA only)

For the location of a Brother authorized service center, call 1-800-284-4357.

Service Center Locations (Canada only)

For the location of a Brother authorized service center, call 1-877-BROTHER.

Brother fax back system (USA only)

Brother has installed an easy-to-use fax back system, so you can get instant answers to common technical questions and product information for all Brother products. This system is available 24 hours a day, 7 days a week. You can use the system to receive faxed instructions and an Index of fax back subjects.

In USA only: 1-800-521-2846

Ordering accessories and supplies

For best quality results use only genuine Brother accessories, which are available at most Brother retailers. If you cannot find the accessory you need and you have a Visa, MasterCard, Discover, or American Express credit card, you can order accessories directly from Brother. (In the USA, you can visit us online for a complete selection of the Brother accessories and supplies that are available for purchase.)

In USA: 1-888-879-3232 (voice)
1-800-947-1445 (fax)

<http://www.brothermall.com>

In Canada: 1-877-BROTHER (voice)

Description	Item
Ink Cartridge Standard <black>	LC51BK (Prints approx. 500 pages)
Ink Cartridge <yellow>	LC51Y (Prints approx. 400 pages)
Ink Cartridge <cyan> (blue)	LC51C (Prints approx. 400 pages)
Ink Cartridge <magenta> (red)	LC51M (Prints approx. 400 pages)
Premium Glossy Photo Paper (Letter size / 20 sheets)	BP61GLL ¹
Premium Glossy Photo Paper (4"x6" size / 20 sheets)	BP61GLP ¹
Matte Inkjet Paper (Letter size / 25 sheets)	BP60ML (USA only)
Inkjet Plain Paper (Letter size / 250 sheets)	BP60PL (USA only)
User's Guide	LP3289001 (English for USA and Canada) LP3289002 (French for Canada)

¹ Available in the USA and from November 2006 in Canada.

Notice - Disclaimer of Warranties (USA and Canada)

BROTHER'S LICENSOR(S), AND THEIR DIRECTORS, OFFICERS, EMPLOYEES OR AGENTS (COLLECTIVELY BROTHER'S LICENSOR) MAKE NO WARRANTIES, EXPRESS OR IMPLIED, INCLUDING WITHOUT LIMITATION THE IMPLIED WARRANTIES OF MERCHANTABILITY AND FITNESS FOR A PARTICULAR PURPOSE, REGARDING THE SOFTWARE. BROTHER'S LICENSOR(S) DOES NOT WARRANT, GUARANTEE OR MAKE ANY REPRESENTATIONS REGARDING THE USE OR THE RESULTS OF THE USE OF THE SOFTWARE IN TERMS OF ITS CORRECTNESS, ACCURACY, RELIABILITY, CURRENTNESS OR OTHERWISE. THE ENTIRE RISK AS TO THE RESULTS AND PERFORMANCE OF THE SOFTWARE IS ASSUMED BY YOU. THE EXCLUSION OF IMPLIED WARRANTIES IS NOT PERMITTED BY SOME STATES IN THE USA AND SOME PROVINCES IN CANADA. THE ABOVE EXCLUSION MAY NOT APPLY TO YOU.

IN NO EVENT WILL BROTHER'S LICENSOR(S) BE LIABLE TO YOU FOR ANY CONSEQUENTIAL, INCIDENTAL OR INDIRECT DAMAGES (INCLUDING DAMAGES FOR LOSS OF BUSINESS PROFITS, BUSINESS INTERRUPTION, LOSS OF BUSINESS INFORMATION, AND THE LIKE) ARISING OUT OF THE USE OR INABILITY TO USE THE SOFTWARE EVEN IF BROTHER'S LICENSOR HAS BEEN ADVISED OF THE POSSIBILITY OF SUCH DAMAGES. BECAUSE SOME STATES IN THE USA AND SOME PROVINCES IN CANADA DO NOT ALLOW THE EXCLUSION OR LIMITATION OF LIABILITY FOR CONSEQUENTIAL OR INCIDENTAL DAMAGES, THE ABOVE LIMITATIONS MAY NOT APPLY TO YOU. IN ANY EVENT BROTHER'S LICENSOR'S LIABILITY TO YOU FOR ACTUAL DAMAGES FROM ANY CAUSE WHATSOEVER, AND REGARDLESS OF THE FORM OF THE ACTION (WHETHER IN CONTRACT, TORT (INCLUDING NEGLIGENCE), PRODUCT LIABILITY OR OTHERWISE), WILL BE LIMITED TO \$50.

Compilation and Publication Notice

Under the supervision of Brother Industries Ltd., this manual has been compiled and published, covering the latest product descriptions and specifications.

The contents of this manual and the specifications of this product are subject to change without notice.

Brother reserves the right to make changes without notice in the specifications and materials contained herein and shall not be responsible for any damages (including consequential) caused by reliance on the materials presented, including but not limited to typographical and other errors relating to the publication.

Brother® One Year Limited Warranty and Replacement Service (USA only)

Who is covered:

- This limited warranty (“warranty”) is given only to the original end-use/retail purchaser (referred to in this warranty as “Original Purchaser”) of the accompanying product, consumables and accessories (collectively referred to in this warranty as “this Product”).
- If you purchased a product from someone other than an authorized Brother reseller in the United States or if the product was used (including but not limited to floor models or refurbished product), prior to your purchase you are not the Original Purchaser and the product that you purchased is not covered by this warranty.

What is covered:

- This Product includes a Machine and Consumable and Accessory Items. Consumable and Accessory Items include but are not limited to print heads, toner, drums, ink cartridges, print cartridges, refill ribbons, therma PLUS paper and thermal paper.
- Except as otherwise provided herein, Brother warrants that the Machine and the accompanying Consumable and Accessory Items will be free from defects in materials and workmanship, when used under normal conditions.
- This warranty applies only to products purchased and used in the United States. For products purchased in, but used outside, the United States, this warranty covers only warranty service within the United States (and does not include shipping outside the United States).

What is the length of the Warranty Periods:

- Machines: one year from the original purchase date.
- Accompanying Consumable and Accessory Items: 90 days from the original purchase date or the rated life of consumable, whichever comes first.

What is NOT covered:

This warranty does not cover:

- 1 Physical damage to this Product;
- 2 Damage caused by improper installation, improper or abnormal use, misuse, neglect or accident (including but not limited to transporting this Product without the proper preparation and/or packaging);

- 3 Damage caused by another device or software used with this Product (including but not limited to damage resulting from use of non Brother®-brand parts and Consumable and Accessory Items);
- 4 Consumable and Accessory Items that expired in accordance with a rated life; and,
- 5 Problems arising from other than defects in materials or workmanship.
- 6 Normal Periodic Maintenance Items, such as Paper Feeding Kit, Fuser and Laser Units.

This limited warranty is VOID if this Product has been altered or modified in any way (including but not limited to attempted warranty repair without authorization from Brother and/or alteration/removal of the serial number).

What to do if you think your Product is eligible for warranty service:

Report your issue to either our Customer Service Hotline at 1-800-284-4329 for Fax, MFC and DCP and 1-800-276-7746 for Printers, or to a Brother Authorized Service Center **within the applicable warranty period.** Supply Brother or the Brother Authorized Service Center with a copy of your dated bill of sale showing that this Product was purchased within the U.S. For the name of local Brother Authorized Service Center(s), call 1-800-521-2846.

What Brother will ask you to do:

After contacting Brother or a Brother Authorized Service Center, you may be required to deliver (by hand if you prefer) or send the Product properly packaged, freight prepaid, to the Authorized Service Center together with a photocopy of your bill of sale.

You are responsible for the cost of shipping, packing product, and insurance (if you desire). You are also responsible for loss or damage to this Product in shipping.

What Brother will do:

If the problem reported concerning your Machine and/or accompanying Consumable and Accessory Items is covered by this warranty and if you first reported the problem to Brother or an Authorized Service Center within the applicable warranty period, Brother or its Authorized Service Center will repair or replace the Machine and/or accompanying Consumable and Accessory Items at no charge to you for parts or labor. The decision as to whether to repair or replace the Machine and/or accompanying Consumable and Accessory Items is made by Brother in its sole

Brother® One Year Limited Warranty and Replacement Service (USA only)

discretion. Brother reserves the right to supply a refurbished or remanufactured replacement Machine and/or accompanying Consumable and Accessory Items and use refurbished parts provided such replacement products conform to the manufacturer's specifications for new product/parts. The repaired or replacement Machine and/or accompanying Consumable and Accessory Items will be returned to you freight prepaid or made available for you to pick up at a conveniently located Authorized Service Center.

If the Machine and/or accompanying Consumable and Accessory Items are not covered by this warranty (either stage), you will be charged for shipping the Machine and/or accompanying Consumable and Accessory Items back to you and charged for any service and/or replacement parts/products at Brother's then current published rates.

The foregoing are your sole (i.e., only) and exclusive remedies under this warranty.

What happens when Brother elects to replace your Machine:

When a replacement Machine is authorized by Brother, and you have delivered the Machine to an Authorized Service Center, the Authorized Service Center will provide you with a replacement Machine after receiving one from Brother. If you are dealing directly with Brother, Brother will send to you a replacement Machine with the understanding that you will, after receipt of the replacement Machine, supply the required proof of purchase information, together with the Machine that Brother agreed to replace. You are then expected to pack the Machine that Brother agreed to replace in the package from the replacement Machine and return it to Brother using the pre-paid freight bill supplied by Brother in accordance with the instructions provided by Brother. Since you will be in possession of two machines, Brother will require that you provide a valid major credit card number. Brother will issue a hold against the credit card account number that you provide until Brother receives your original Product and determines that your original Product is entitled to warranty coverage. Your credit card will be charged up to the cost of a new Product only if: (i) you do not return your original Product to Brother within five (5) business days; (ii) the problems with your original Product are not covered by the limited warranty; (iii) the proper packaging instructions are not followed and has caused damage to the product; or (iv) the warranty period on your original Product has expired or has not been sufficiently validated with a copy of the proof of purchase (bill of

sale). The replacement Machine you receive (even if refurbished or remanufactured) will be covered by the balance of the limited warranty period remaining on the original Product, plus an additional thirty (30) days. You will keep the replacement Machine that is sent to you and your original Machine shall become the property of Brother. **Retain your original Accessory Items and a copy of the return freight bill, signed by the courier.**

Limitations:

Brother is not responsible for damage to or loss of any equipment, media, programs or data related to the use of this Product. Except for that repair or replacement as described above, Brother shall not be liable for any direct, indirect, incidental or consequential damages or specific relief. Because some states do not allow the exclusion or limitation of consequential or incidental damages, the above limitation may not apply to you.

THIS WARRANTY IS GIVEN IN LIEU OF ALL OTHER WARRANTIES, WRITTEN OR ORAL, WHETHER EXPRESSED BY AFFIRMATION, PROMISE, DESCRIPTION, DRAWING, MODEL OR SAMPLE. ANY AND ALL WARRANTIES OTHER THAN THIS ONE, WHETHER EXPRESS OR IMPLIED, INCLUDING IMPLIED WARRANTIES OF MERCHANTABILITY AND FITNESS FOR A PARTICULAR PURPOSE, ARE HEREBY DISCLAIMED.

- This Limited Warranty is the only warranty that Brother is giving for this Product. It is *the final expression and the exclusive and only statement* of Brother's obligations to you. It replaces all other agreements and understandings that you may have with Brother or its representatives.
- This warranty gives you certain rights and you may also have other rights that may vary from state to state.
- This Limited Warranty (and Brother's obligation to you) may not be changed in any way unless you and Brother sign the same piece of paper in which we (1) refer to this Product and your bill of sale date, (2) describe the change to this warranty and (3) agree to make that change.

Important:

We recommend that you keep all original packing materials, in the event that you ship this Product.

BROTHER MULTIFUNCTION CENTER/FACSIMILE MACHINE LIMITED WARRANTY (Canada only)

Pursuant to this limited warranty of 1 year from the date of purchase for labour and parts, Brother International Corporation (Canada) Ltd. ("Brother"), or its Authorized Service Centers, will repair this MFC/Facsimile machine free of charge if defective in material or workmanship. This Limited Warranty does not include cleaning, consumables (including, without limitation, print cartridges, print head, toner and drum) or damage caused by accident, neglect, misuse or improper installation or operation, any damage caused from service, maintenance, modifications, or tampering by anyone other than a Brother Authorized Service Representative, or from the use of supplies or consumable items that are non-Brother products. Operation of the MFC/Facsimile machine in excess of the specifications or with the Serial Number or Rating Label removed shall be deemed abuse and all repairs thereafter shall be the sole liability of the end-user/purchaser. In order to obtain warranty service, the MFC/Facsimile machine must be delivered or shipped freight prepaid by the end user/purchaser to a "Brother" Authorized Service Center, together with your Proof of Purchase in the form of a Sales Receipt.

For laser products: Failure to remove the Toner Cartridge (and Toner Drum Unit on applicable models) during shipping will cause severe damage to the MFC/Facsimile and will VOID the Warranty. (Refer to your User's Guide for proper packaging.)

For ink-jet products: Do not remove the ink cartridges during shipping. Damage to your print head resulting from packing without the ink cartridges will VOID your warranty. (Refer to your User's Guide for proper packaging.)

BROTHER DISCLAIMS ALL OTHER WARRANTIES EXPRESSED OR IMPLIED INCLUDING, WITHOUT LIMITATION, ANY IMPLIED WARRANTIES OF MERCHANTABILITY OR FITNESS FOR A PARTICULAR PURPOSE, EXCEPT TO THE EXTENT THAT ANY WARRANTIES IMPLIED BY LAW CANNOT BE VALIDLY WAIVED.

No oral or written information, advice or representation provided by Brother, its Authorized Service Centers, Distributors, Dealers, Agents or employees, shall create another warranty or modify this warranty. This warranty states Brother's entire liability and your exclusive remedy against Brother for any failure of the MFC/Facsimile machine to operate properly.

Neither Brother nor anyone else involved in the development, production, or delivery of this MFC/Facsimile machine shall be liable for any indirect, incidental, special, consequential, exemplary, or punitive damages, including lost profits, arising from the use of or inability to use the product, even if advised by the end user/purchaser of the possibility of such damages. Since some Provinces do not allow the above limitation of liability, such limitation may not apply to you.

This Limited Warranty gives you specific legal rights and you may also have other rights which vary from Province to Province.

Warranty Service is available at Brother Authorized Service Centers throughout Canada. For Technical Support or for the name and location of your nearest Authorized Service Center call 1-877-BROTHER.

Internet support: support@brother.ca or browse

Brother's Web Site: www.brother.com

Brother International Corporation (Canada) Ltd.

1 Rue Hôtel de Ville

Dollard-Des-Ormeaux, QC H9B 3H6

At your side.
brother®

Table of Contents

Section I General

1 General Information

Using the documentation	2
Symbols and conventions used in the documentation	2
Accessing the Software User's Guide and Network User's Guide	2
Viewing Documentation	2
Accessing Brother Support (For Windows®)	5
Control panel overview	6
LCD display screen	8
Basic Operations	8
Status LED indications	9
Printing Reports	9

2 Loading documents and paper

Loading documents	10
Using the ADF (DCP-540CN only)	10
Using the scanner glass	11
Scannable area	11
Acceptable paper and other media	12
Recommended media	12
Handling and using media	12
Choosing the right media	14
Loading paper and other media	16
Loading envelopes and post cards	18
Loading photo paper	20
Removing small printouts from the machine	21
Printable Area	22

3 General setup

Paper settings	23
Paper Type	23
Paper Size	23
LCD display	24
LCD Contrast	24
Setting the backlight brightness	24
Setting the Dim Timer for the backlight	25
Setting the Off Timer	25

Section II Copy

4 Making copies

How to copy	28
Making a single copy	28
Making multiple copies	28
Stop copying	28
Copy options	28
Changing and quality	29
Enlarging or reducing the image copied	29
Making N in 1 copies or a poster (page layout)	30
Sorting copies using the ADF (DCP-540CN only)	31
Adjusting Brightness, Contrast and Color	31
Paper options	32
Setting your changes as new default	33
Restoring all the settings to factory settings	33

Section III Walk-up Photo Printing

5 PhotoCapture Center®

PhotoCapture Center® Operations	36
Printing from a media card without a PC	36
Scanning to a media card without a PC	36
Using PhotoCapture Center® from your computer	36
Using media cards	36
Media card folder structure	37
Getting started	37
Entering PhotoCapture mode	38
Print Images	38
View Photo(s)	38
Print Index (Thumbnails)	39
Print All Photos	39
Print Photos	40
DPOF printing	40
PhotoCapture Center® print settings	41
Print Quality	42
Paper options	42
Adjusting Brightness, Contrast and Color	43
Cropping	44
Borderless printing	44
Setting your changes as new default	44
Restoring all the settings to factory settings	44
Scan to Card	45
Entering Scan mode	45
How to scan to card	45
Understanding the Error Messages	46

6 PictBridge

Before Using PictBridge.....	47
PictBridge requirements	47
Using PictBridge	47
Setting your digital camera	47
Printing Images.....	48
DPOF printing.....	48
Understanding the Error Messages	49

Section IV Software

7 Software and Network features

Section V Appendixes

A Safety and Legal

Choosing a location	54
To use the machine safely.....	55
Important safety instructions.....	58
Federal Communications Commission (FCC) Declaration of Conformity (USA only).....	60
Industry Canada Compliance Statement (Canada only)	61
LAN connection (DCP-540CN only)	61
Legal limitations for copying	61
Trademarks	62

B Troubleshooting and Routine Maintenance

Troubleshooting	63
If you are having difficulty with your machine	63
Error messages	67
Document jam (DCP-540CN only)	69
Printer jam or paper jam	70
Routine maintenance.....	72
Replacing the ink cartridges	72
Cleaning the outside of the machine	74
Cleaning the scanner.....	75
Cleaning the machine printer platen.....	75
Cleaning the paper pick-up roller.....	76
Cleaning the print head	76
Checking the print quality	77
Checking the print alignment	78
Checking the ink volume	78
Machine Information	79
Checking the serial number.....	79
Packing and shipping the machine.....	79

C Menu and Features

On-screen programming	81
Menu table	81
Menu keys	81
Menu table	82

D Specifications

General	89
Print media	91
Copy	92
PhotoCapture Center®	93
PictBridge	94
Scanner	94
Printer	95
Interfaces	95
Computer requirements	96
Consumable items	97
Network (LAN) (DCP-540CN only)	98

E Glossary

F Index



General

General Information	2
Loading documents and paper	10
General setup	23

Using the documentation

Thank you for buying a Brother machine! Reading the documentation will help you make the most of your machine.

Symbols and conventions used in the documentation

The following symbols and conventions are used throughout the documentation.

Bold Bold typeface identifies specific keys on the machine's control panel.

Italics Italicized typeface emphasizes an important point or refers you to a related topic.

`Courier New` Text in the Courier New font identifies messages on the LCD of the machine.



Warnings tell you what to do to prevent possible personal injury.



Electrical Hazard icons alert you to possible electrical shock.



Hot Surface icons warn you not to touch machine parts that are hot.



Cautions specify procedures you must follow or avoid to prevent possible damage to the machine or other objects.



Notes tell you how you should respond to a situation that may arise or give tips about how the operation works with other features.



Improper Setup icons alert you to devices and operations that are not compatible with the machine.

Accessing the Software User's Guide and Network User's Guide

This User's Guide does not contain all the information about the machine such as how to use advanced features of Printer, Scanner and Network (DCP-540CN only). When you are ready to learn detailed information about these operations, read the **Software User's Guide** and **Network User's Guide** that are on the CD-ROM.

Viewing Documentation

Viewing Documentation (For Windows®)

To view the documentation, from the **Start** menu, point to **Brother, DCP-XXXX** (where XXXX is your model name) from the programs group, and then select **User's Guide**.

If you have not installed the software, you can find the documentation by following the instructions below:

- 1 Turn on your PC. Insert the Brother CD-ROM into your CD-ROM drive.
- 2 If the model name screen appears, click your model name.

- 3 If the language screen appears, click your language. The CD-ROM main menu will appear.

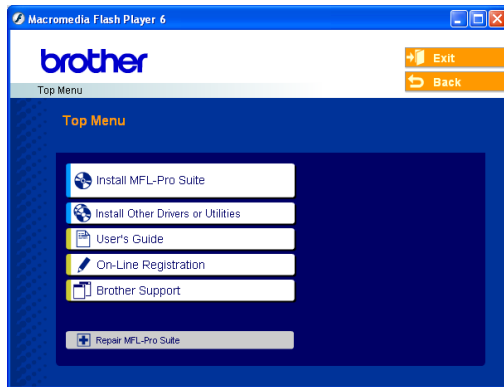

Note

If this window does not appear, use Windows[®] Explorer to run the setup.exe program from the root directory of the Brother CD-ROM.

- 4 Click **User's Guide** to view the **Software User's Guide** and **Network User's Guide** in HTML format.

How to find Scanning instructions

There are several ways you can scan documents. You can find the instructions as follows:

Software User's Guide

- *Scanning*
(For Windows[®] 98/98SE/Me/2000 Professional and Windows[®] XP)
- *ControlCenter3*
(For Windows[®] 98/98SE/Me/2000 Professional and Windows[®] XP)
- *Network Scanning*
(DCP-540CN only)

PaperPort[®] SE with OCR User's Guide

- The complete ScanSoft[®] PaperPort[®] SE with OCR User's Guide can be viewed from the Help selection in the ScanSoft[®] PaperPort[®] SE with OCR application.

Viewing Documentation (For Macintosh®)

- 1 Turn on your Macintosh®. Insert the Brother CD-ROM into your CD-ROM drive. The following window will appear.

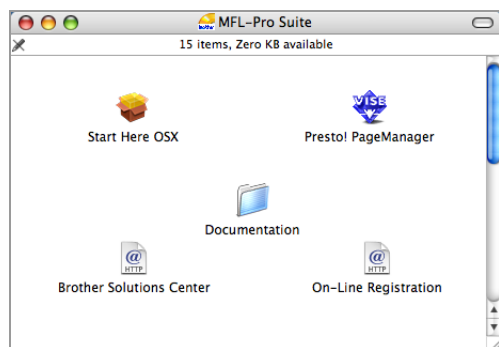

- 2 Double-click the **Documentation** icon.
- 3 Double-click your language folder.
- 4 Double-click the top page file to view the **Software User's Guide** and **Network User's Guide** in HTML format.
- 5 Click the documentation you want to read.
 - **Software User's Guide**
 - **Network User's Guide**
(DCP-540CN only)

How to find Scanning instructions

There are several ways you can scan documents. You can find the instructions as follows:

Software User's Guide

- **Scanning**
(For Mac OS® X 10.2.4 or greater)
- **ControlCenter2**
(For Mac OS® X 10.2.4 or greater)
- **Network Scanning**
(For Mac OS® X 10.2.4 or greater)
(DCP-540CN only)

Presto!® PageManager® User's Guide

- The complete Presto!® PageManager® User's Guide can be viewed from the Help selection in the Presto!® PageManager® application.

Accessing Brother Support (For Windows®)

You can find all the contacts you will need, such as Web support (Brother Solutions Center), Customer Service and Brother Authorized Service Centers on page i and on the Brother CD-ROM.

- Click **Brother Support** on the main menu. The following screen will appear:

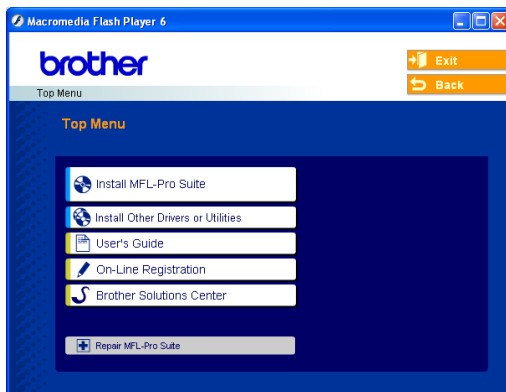

- To access our web site (www.brother.com), click **Brother Home Page**.
- To view all Brother Numbers, including Customer Service numbers for the USA and Canada, click **Support Information**.
- To access the USA Brother online shopping mall (www.brothermall.com) for additional product and services information, click **Brother Mall.com**.
- For the latest news and product support information (<http://solutions.brother.com>), click **Brother Solutions Center**.
- To return to the main page, click **Back** or If you have finished, click **Exit**.

Control panel overview

The **DCP-330C** and **DCP-540CN** have the same control panel keys.

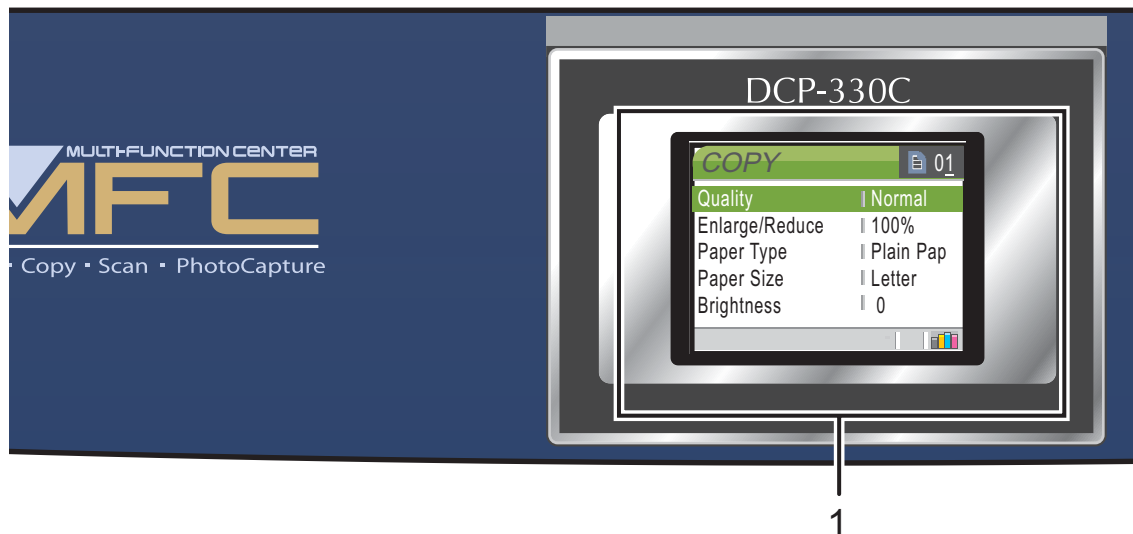

Note

Most of the illustrations in this User's Guide show the DCP-330C.

1 LCD (liquid crystal display)

Displays messages on the screen to help you set up and use your machine.

Also, you can adjust the angle of the LCD display by lifting it.

2 Number of Copies

Use this key to make multiple copies.

3 Menu keys:

- ◀ or ▶

Press to scroll backward or forward to a menu selection.

- ▲ or ▼

Press to scroll through the menus and options.

- **Menu**

Lets you access the main menu to program the machine.

- **OK**

Lets you select a setting.

4 Start keys:

-  **Color Start**

Lets you start making copies in full color. Also lets you start a scanning operation (in color or black & white, depending on the scanning setting in the ControlCenter software).

-  **Black Start**

Lets you start making copies in black & white. Also lets you start a scanning operation (in color or black & white, depending on the scanning setting in the ControlCenter software).

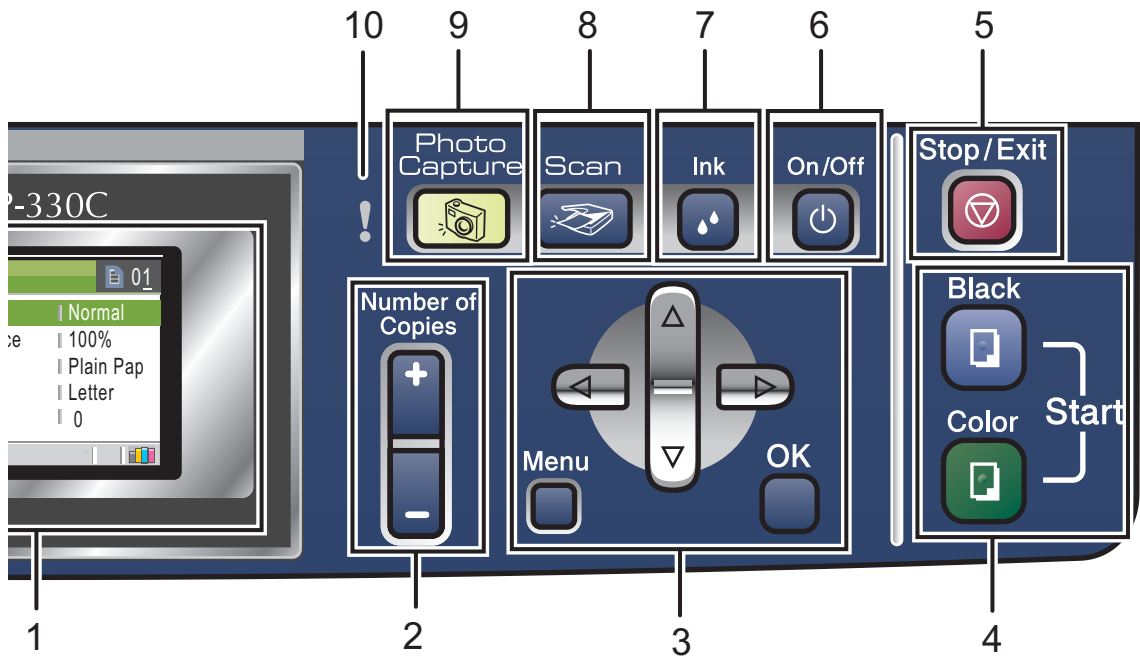

5 Stop/Exit

Stops an operation or exits from a menu.

6 On/Off

You can turn the machine on or off.

If you turn the machine off, it will still periodically clean the print head to maintain print quality.

7 Ink

Lets you clean the print head, check the print quality, and check the available ink volume.

8 Scan

Lets you access Scan mode.

9 PhotoCapture

Lets you access PhotoCapture Center[®] mode.

10 Status LED

Turns red when the LCD displays an error or an important status message.

LCD display screen

The LCD display screen shows the mode the machine is in, the current settings, and the available ink volume.

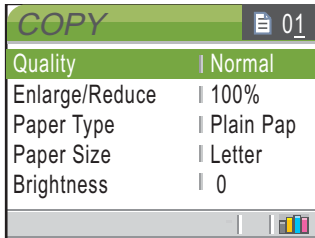

1

1 Ink indicator

Lets you see the available ink volume.

Basic Operations

The following steps show how to change a setting in the machine. In this example the Paper Type setting is changed from Plain Paper to Inkjet Paper.

- 1 Press **Menu**.
- 2 Press **▲** or **▼** to choose General Setup.

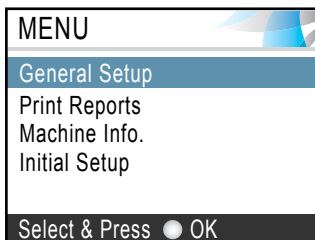

Press **OK**.

- 3 Press **▲** or **▼** to choose Paper Type.

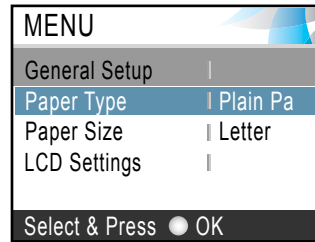

Press **OK**.

- 4 Press **▲** or **▼** to choose Inkjet Paper.

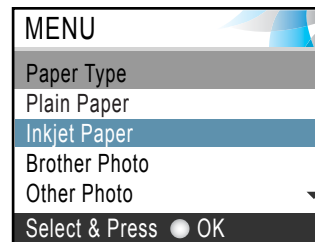

Press **OK**.

You can see the current setting on the LCD:

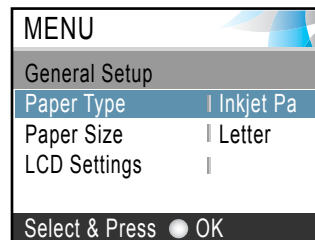

- 5 Press **Stop/Exit**.

Status LED indications

The Status LED (light emitting diode) is a light that shows the status of the machine, as shown in the table.



LED	DCP status	Description
! Off	Ready	The DCP is ready for use.
! Red	Cover open	The cover is open. Close the cover. (See <i>Error messages</i> on page 67.)
	Ink empty	Replace the Ink cartridge with a new one. (See <i>Replacing the ink cartridges</i> on page 72.)
	Paper error	Put paper in the tray or clear the paper jam. Check the LCD message. (See <i>Error messages</i> on page 67.)
	Other messages	Check the LCD message. (See <i>Error messages</i> on page 67.)

Printing Reports

The following reports are available:

- **Help List**
A help list about how to quickly program your machine.
- **User Settings**
Lists your settings.
- **Network config (DCP-540CN only)**
Lists your Network settings.

How to print a report

- 1 Press **Menu**.
- 2 Press **▲** or **▼** to choose **Print Reports**. Press **OK**.
- 3 Press **▲** or **▼** to choose the report you want. Press **OK**.
- 4 Press **Black Start**.

2

Loading documents and paper

Loading documents

You can make copies, and scan from the ADF (automatic document feeder) and from the scanner glass.

Using the ADF (DCP-540CN only)

The ADF can hold up to 10 pages and feeds each sheet individually. Use standard 20 lb (80 g/m²) paper and always fan the pages before putting them in the ADF.

Recommended environment

Temperature:	68 to 86° F (20 to 30° C)
Humidity:	50% to 70%
Paper:	20 lb LTR (80 g/m ² A4)

Document Sizes Supported

Length:	5.8 to 14 in. (148 to 355.6 mm)
Width:	5.8 to 8.5 in. (148 to 215.9 mm)
Weight:	17 to 24 lb (64 to 90 g/m ²)

How to load documents

! CAUTION

DO NOT pull on the document while it is feeding.

DO NOT use paper that is curled, wrinkled, folded, ripped, stapled, paper clipped, pasted or taped.

DO NOT use cardboard, newspaper or fabric.

■ Make sure documents written with ink are completely dry.

- 1 Fan the pages well. Make sure you put the documents **face down, top edge first** in the ADF until you feel them touch the feed roller.
- 2 Adjust the paper guides to fit the width of your documents.
- 3 Unfold the ADF Document Output Support Flap (1).

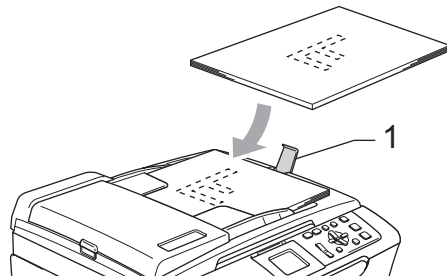

! CAUTION

DO NOT leave thick documents on the scanner glass. If you do this, the ADF may jam.

Using the scanner glass

You can use the scanner glass to copy or scan pages of a book or one page at a time.

Document Sizes Supported

Length:	Up to 11.7 in. (297 mm)
Width:	Up to 8.5 in. (215.9 mm)
Weight:	Up to 4.4 lb (2 kg)

How to load documents



Note

To use the scanner glass, the ADF must be empty.

- 1 Lift the document cover.

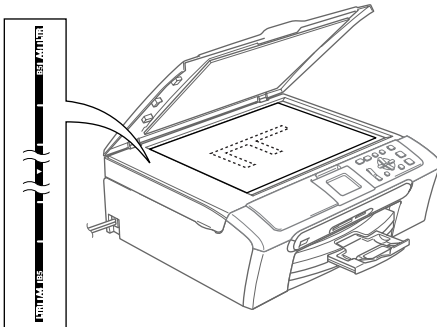

- 2 Using the document guidelines on the left, center the document face down on the scanner glass.

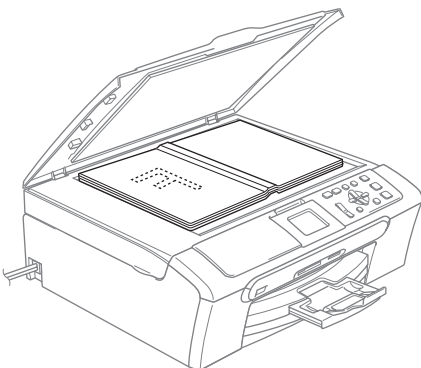

- 3 Close the document cover.

! CAUTION

If you are scanning a book or thick document, DO NOT slam the cover down or press on it.

2

Scannable area

The scannable area depends on the settings in the application you are using. The figures below show the areas you cannot scan on paper.

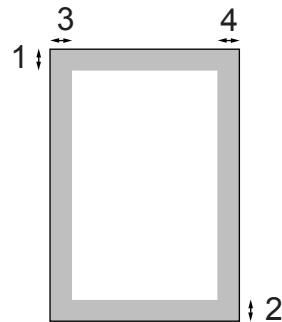

Usage	Document Size	Top (1) Bottom (2)	Left (3) Right (4)
Copy	Letter	0.12 in. (3 mm)	0.12 in. (3 mm)
	A4	0.12 in. (3 mm)	0.12 in. (3 mm)
Scan	Letter	0.12 in. (3 mm)	0.12 in. (3 mm)
	A4	0.12 in. (3 mm)	0 in. (0 mm)

Acceptable paper and other media

The print quality can be affected by the type of paper you are using in the machine.

To get the best print quality for the settings you have chosen, always set the Paper Type to match the type of paper you load.

You can use plain paper, inkjet paper (coated paper), glossy paper, transparencies and envelopes.

We recommend testing various paper types before buying large quantities.

For best results, use the Brother paper.

- When you print on inkjet paper (coated paper), transparencies and glossy paper, be sure to choose the proper media in the 'Basic' tab of the printer driver or in the Paper Type setting of the menu.
- When you print on Brother photo paper, load the instruction sheet included with the photo paper in the paper tray first, and then put the photo paper on the instruction sheet.
- When you use transparencies or photo paper, remove each sheet at once to prevent smudging or paper jams.
- Avoid touching the printed surface of the paper immediately after printing; the surface may not be completely dry and may stain your fingers.

Recommended media

To get the best print quality, we suggest using Brother paper. (See the table below.)

We recommend using '3M Transparency Film' when you print on transparencies.

Brother paper

Paper Type	Item
Letter Plain	BP60PL (USA only)
Letter Glossy Photo	BP61GLL ¹
Letter Inkjet (Matte)	BP60ML (USA only)
4 × 6 in. Glossy Photo	BP61GLP ¹

¹ Available in the USA and from November 2006 in Canada.

Handling and using media

- Store paper in its original packaging, and keep it sealed. Keep the paper flat and away from moisture, direct sunlight and heat.
- The coated side of photo paper is shiny. Avoid touching the shiny (coated) side. Load photo paper with the shiny side facing down.
- Avoid touching either side of transparencies because they absorb water and perspiration easily, and this may cause decreased output quality. Transparencies designed for laser printers/copiers may stain your next document. Use only transparencies recommended for inkjet printing.

Improper Setup

DO NOT use the following kinds of paper:

- Damaged, curled, wrinkled, or irregularly shaped paper

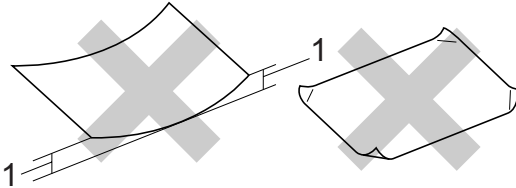

1 0.08 in. (2 mm) or longer

- Extremely shiny or highly textured paper
- Paper already printed on by a printer
- Paper that cannot be arranged uniformly when stacked
- Paper made with a short grain

Paper capacity of the output paper tray

Up to 50 sheets of 20 lb Letter or 80 g/m² A4 paper.

- Transparencies or photo paper must be picked up from the output paper tray one page at a time to avoid smudging.

Choosing the right media

Paper type and size for each operation

Paper Type	Paper Size		Usage		
			Copy	Photo Capture	Print
Cut Sheet	Letter	8 1/2 × 11 in. (216 × 279 mm)	Yes	Yes	Yes
	A4	8.3 × 11.7 in. (210 × 297 mm)	Yes	Yes	Yes
	Legal	8 1/2 × 14 in. (216 × 356 mm)	Yes	–	Yes
	Executive	7 1/4 × 10 1/2 in. (184 × 267 mm)	–	–	Yes
	JIS B5	7.2 × 10.1 in. (182 × 257 mm)	–	–	Yes
	A5	5.8 × 8.3 in. (148 × 210 mm)	Yes	–	Yes
	A6	4.1 × 5.8 in. (105 × 148 mm)	–	–	Yes
Cards	Photo	4 × 6 in. (10 × 15 cm)	Yes	Yes	Yes
	Photo L	3 1/2 × 5 in. (89 × 127 mm)	–	–	Yes
	Photo 2L	5 × 7 in. (127 × 178 mm)	–	Yes	Yes
	Index Card	5 × 8 in. (127 × 203 mm)	–	–	Yes
	Post Card 1	3.9 × 5.8 in. (100 × 148 mm)	–	–	Yes
	Post Card 2 (Double)	5.8 × 7.9 in. (148 × 200 mm)	–	–	Yes
Envelopes	C5 Envelope	6.4 × 9 in. (162 × 229 mm)	–	–	Yes
	DL Envelope	4.3 × 8.7 in. (110 × 220 mm)	–	–	Yes
	COM-10	4 1/8 × 9 1/2 in. (105 × 241 mm)	–	–	Yes
	Monarch	3 7/8 × 7 1/2 in. (98 × 191 mm)	–	–	Yes
	JE4 Envelope	4.1 × 9.3 in. (105 × 235 mm)	–	–	Yes
	Transparencies	Letter	8 1/2 × 11 in. (216 × 279 mm)	Yes	–
A4		8.3 × 11.7 in. (210 × 297 mm)	Yes	–	Yes

Paper weight, thickness and capacity

Paper Type		Weight	Thickness	No. of sheets
Cut Sheet	Plain Paper	17 to 32 lb (64 to 120 g/m ²)	0.003 to 0.006 in. (0.08 to 0.15 mm)	100 ¹
	Inkjet Paper	17 to 53 lb (64 to 200 g/m ²)	0.003 to 0.01 in. (0.08 to 0.25 mm)	20
	Glossy Paper	Up to 58 lb (Up to 220 g/m ²)	Up to 0.01 in. (Up to 0.25 mm)	20
Cards	Photo 4"×6"	Up to 64 lb (Up to 240 g/m ²)	Up to 0.01 in. (Up to 0.28 mm)	20 ¹
	Index Card	Up to 32 lb (Up to 120 g/m ²)	Up to 0.006 in. (Up to 0.15 mm)	30
	Post Card	Up to 53 lb (Up to 200 g/m ²)	Up to 0.01 in. (Up to 0.23 mm)	30
Envelopes		20 to 25 lb (75 to 95 g/m ²)	Up to 0.02 in. (Up to 0.52 mm)	10
Transparencies		–	–	10

¹ Up to 50 sheets for Legal size paper 20 lb (80 g/m²).
Up to 100 sheets of 20 lb (80 g/m²) paper.

² For Photo 4"×6" and Photo L 3.5"×5" paper use the photo bypass tray (for USA) or the photo paper tray (for Canada).
(See *Loading photo paper* on page 20.)

Loading paper and other media



Note

To print on Photo (4"×6") or Photo L (3.5"×5") paper, you must use the photo bypass tray. (See *Loading photo paper* on page 20.)

- 1 Pull the paper tray completely out of the machine.
If the paper support flap is open, close it and lift the output paper tray cover (1).

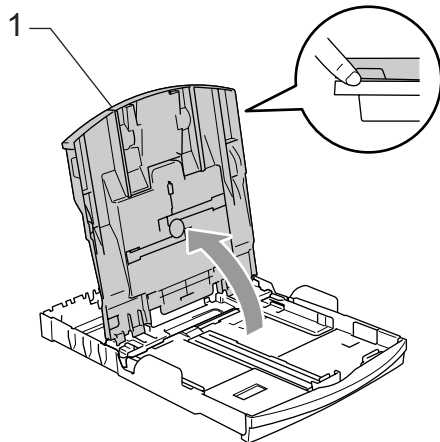
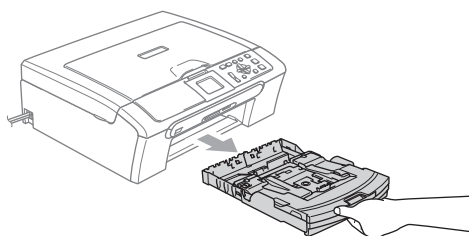

- 2 Press and slide the paper side guides (1) and paper length guide (2) to fit the paper size.

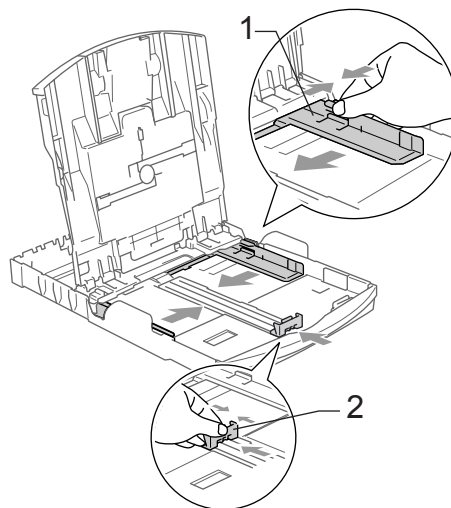

- 3 Fan the stack of paper well to avoid paper jams and misfeeds.

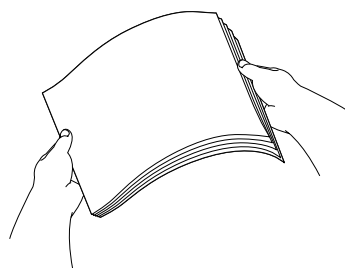

Note

Always make sure that the paper is not curled.

- 4 Gently put the paper into the paper tray print side down and top edge first. Check that the paper is flat in the tray.

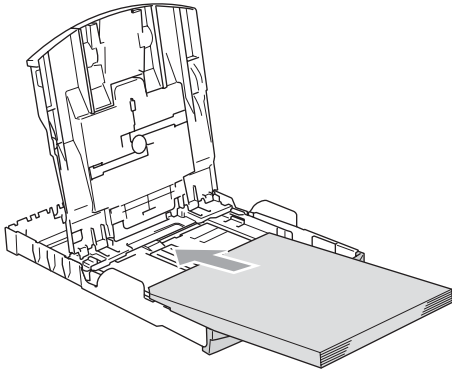

Note

When you use Legal size paper, press and hold the universal guide release button as you slide out the front of the paper tray.

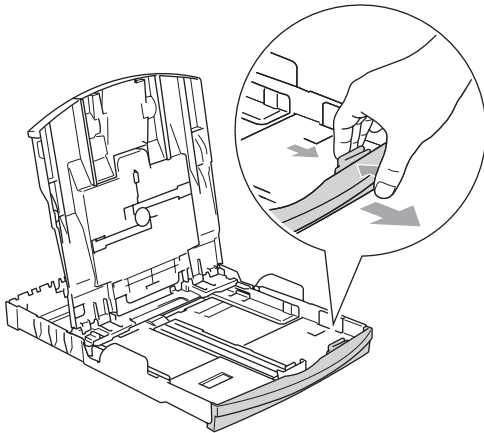

- 5 Gently adjust the paper side guides with both hands and the paper length guide to the paper. Make sure the paper side guides touch the sides of the paper.

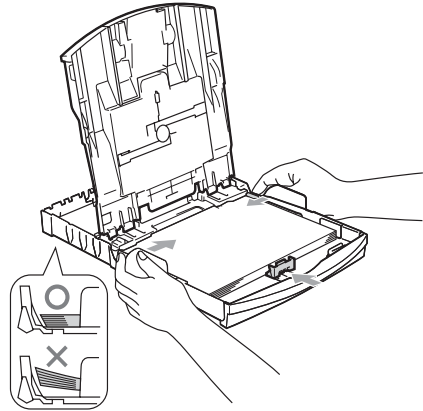

Note

Be careful that you do not push the paper in too far; it may lift at the back of the tray and cause feed problems.

- 6 Close the output paper tray cover.

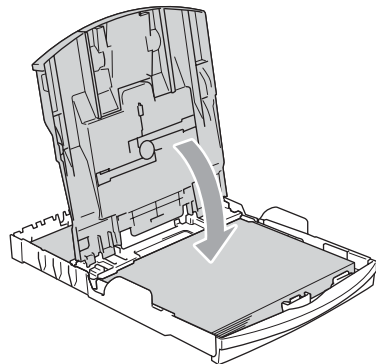

- 7 Slowly push the paper tray completely into the machine.

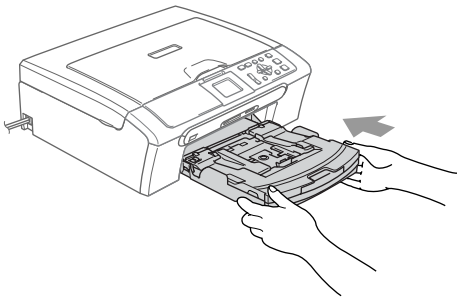

- 8 While holding the paper tray in place, pull out the paper support (1) until it clicks and unfold the paper support flap (2).

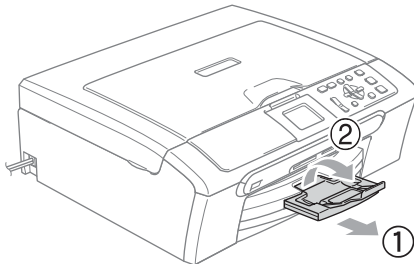

Note

Do not use the paper support flap for Legal paper.

Loading envelopes and post cards

About envelopes

- Use envelopes that weigh from 20 to 25 lb (75 to 95 g/m²).
- Some envelopes need margin settings to be set in the application. Make sure you do a test print first.

! CAUTION

Do not use any of the following types of envelopes, as they will cause paper feed problems:

- That are of a baggy construction.
- That are embossed (have raised writing on them).
- That have clasps or staples.
- That are pre-printed on the inside.

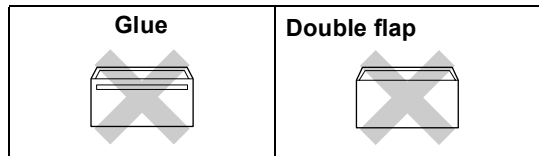

Occasionally you may experience paper feed problems caused by the thickness, size and flap shape of the envelopes you are using.

How to load envelopes and post cards

- 1 Before loading, press the corners and sides of the envelopes or post cards to make them as flat as possible.



Note

If the envelopes or post cards are 'double-feeding,' put one envelope or post card in the paper tray at a time.

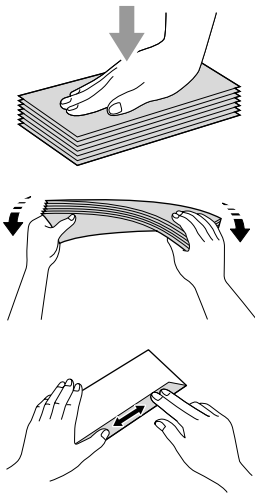

- 1 Put the envelopes or post cards into the paper tray with the address side down and the leading edge in first as shown in the illustration. Slide the paper side guides (1) and paper length guide (2) to fit the size of the envelopes or post cards.

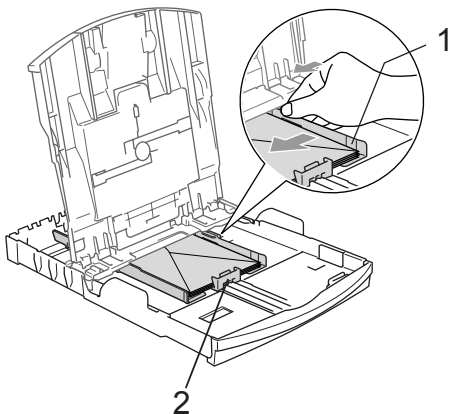

If you have problems when printing on envelopes, try the following suggestions:

- 1 Open the envelope flap.
- 2 Make sure the open flap is either to the side of the envelope or to the back edge of the envelope when printing.
- 3 Adjust the size and margin in your application.

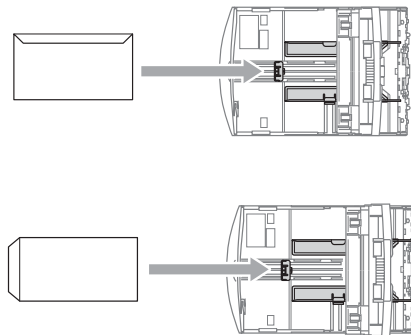

Loading photo paper



Note

In Canada the **photo bypass tray** is called the **photo paper tray**.

Use the photo bypass tray, which has been assembled on the top of the output paper tray cover, to print on photo 4" × 6" and photo L 3.5" × 5" size paper. When you use the photo bypass tray, you do not have to take out the paper that is in the tray beneath it.

- 1 Press the photo bypass tray release button with your left thumb and push the photo bypass tray backward until it clicks into the photo printing position.

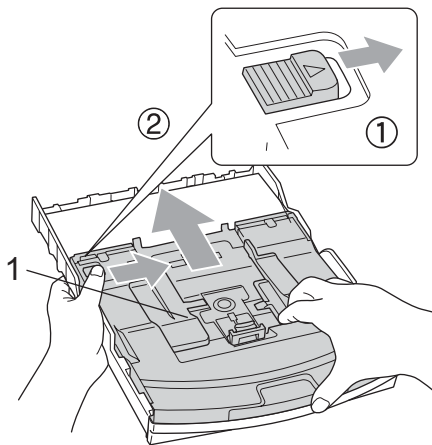

1 Photo Bypass Tray

- 2 Press and slide the paper side guides (1) and paper length guide (2) to fit the paper size.

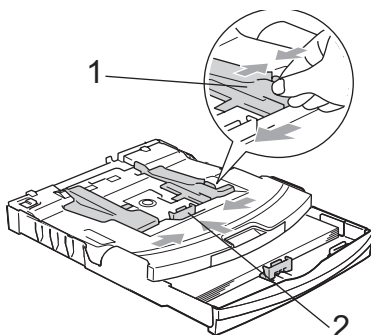

- 3 Put the photo paper into the photo bypass tray and gently adjust the paper side guides to the paper. Make sure the paper side guides touch the sides of the paper.

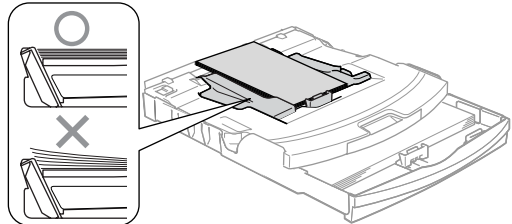

Note

- Be careful that you do not push the paper in too far; it may lift at the back of the tray and cause feed problems.
- Always make sure that the paper is not curled.

- 4 When you have finished printing photos return the photo bypass tray to the normal printing position. Press the photo bypass tray release button with your left thumb and pull the photo bypass tray forward until it clicks.

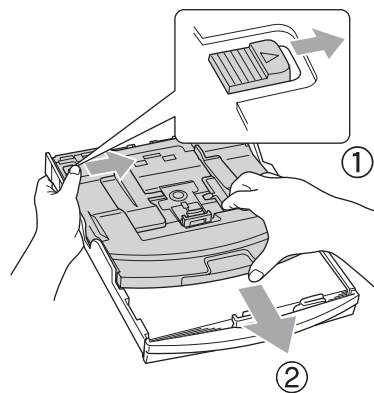

Removing small printouts from the machine

- When the machine ejects small paper onto the output paper tray you may not be able to reach it. Make sure printing has finished, and then pull the tray completely out of the machine.

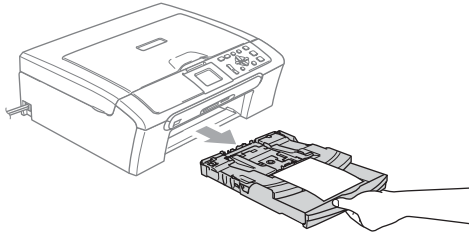

Printable Area

The printable area depends on the settings in the application you are using. The figures below show the unprintable areas on cut sheet paper and envelopes. The machine can only print in the shaded areas when the Borderless print feature is available and turned on.

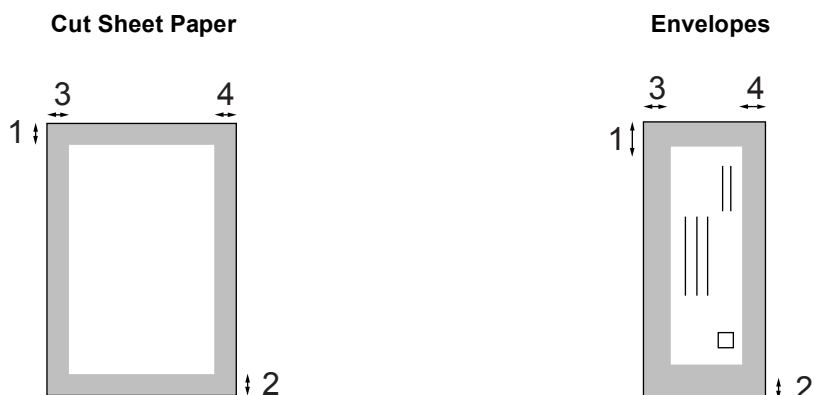

	Top (1)	Bottom (2)	Left (3)	Right (4)
Cut Sheet	0.12 in. (3 mm)	0.12 in. (3 mm)	0.12 in. (3 mm)	0.12 in. (3 mm)
Envelopes	0.47 in. (12 mm)	0.95 in. (24 mm)	0.12 in. (3 mm)	0.12 in. (3 mm)



Note

The Borderless feature is not available for envelopes.

Paper settings

Paper Type

To get the best print quality, set the machine for the type of paper you are using.

- 1 Press **Menu**.
- 2 Press **▲** or **▼** to choose `General Setup`. Press **OK**.
- 3 Press **▲** or **▼** to choose `Paper Type`. Press **OK**.
- 4 Press **▲** or **▼** to choose `Plain Paper`, `Inkjet Paper`, `Brother Photo`, `Other Photo` or `Transparency`. Press **OK**.
- 5 Press **Stop/Exit**.



Note

The machine ejects paper with printed surfaces face up onto the paper tray in front of the machine. When you use transparencies or glossy paper, remove each sheet at once to prevent smudging or paper jams.

Paper Size

You can use five sizes of paper for printing copies: Letter, Legal, A4, A5, and 4 × 6 in. (10 × 15 cm). When you change the size of paper you load in the machine, you will need to change the paper size setting at the same time.

- 1 Press **Menu**.
- 2 Press **▲** or **▼** to choose `General Setup`. Press **OK**.
- 3 Press **▲** or **▼** to choose `Paper Size`. Press **OK**.
- 4 Press **▲** or **▼** to choose `Letter`, `Legal`, `A4`, `A5` or `4"×6"`. Press **OK**.
- 5 Press **Stop/Exit**.

LCD display

LCD Contrast

You can adjust the LCD contrast for a sharper and more vivid display. If you are having difficulty reading the LCD, try changing the contrast setting.

- 1 Press **Menu**.
- 2 Press **▲** or **▼** to choose *General Setup*. Press **OK**.
- 3 Press **▲** or **▼** to choose *LCD Settings*. Press **OK**.
- 4 Press **▲** or **▼** to choose *LCD Contrast*. Press **OK**.
- 5 Press **▲** or **▼** to choose *Light, Med or Dark*. Press **OK**.
- 6 Press **Stop/Exit**.

Setting the backlight brightness

You can adjust the brightness of the LCD backlight. If you are having difficulty reading the LCD, try changing the brightness setting.

- 1 Press **Menu**.
- 2 Press **▲** or **▼** to choose *General Setup*. Press **OK**.
- 3 Press **▲** or **▼** to choose *LCD Settings*. Press **OK**.
- 4 Press **▲** or **▼** to choose *Backlight*. Press **OK**.
- 5 Press **▲** or **▼** to choose *Light, Med or Dark*. Press **OK**.
- 6 Press **Stop/Exit**.

Setting the Dim Timer for the backlight

You can set how long the LCD backlight stays on after the last key press.

- 1 Press **Menu**.
- 2 Press **▲** or **▼** to choose `General Setup`. Press **OK**.
- 3 Press **▲** or **▼** to choose `LCD Settings`. Press **OK**.
- 4 Press **▲** or **▼** to choose `Dim Timer`. Press **OK**.
- 5 Press **▲** or **▼** to choose `10 Secs`, `20 Secs`, `30 Secs` or `Off`. Press **OK**.
- 6 Press **Stop/Exit**.

Setting the Off Timer

You can set how long the LCD stays on after the last key press. This is a power saving feature. The machine can print and scan when the LCD is off.

- 1 Press **Menu**.
- 2 Press **▲** or **▼** to choose `General Setup`. Press **OK**.
- 3 Press **▲** or **▼** to choose `LCD Settings`. Press **OK**.
- 4 Press **▲** or **▼** to choose `Off Timer`. Press **OK**.
- 5 Press **▲** or **▼** to choose `1 Min`, `2 Mins`, `3 Mins`, `5 Mins`, `10 Mins`, `30 Mins` or `Off`. Press **OK**.
- 6 Press **Stop/Exit**.



Note

When the display is off you can press any key to turn it back on.



Copy

Making copies

28

4

Making copies

How to copy

Making a single copy

- 1 Load your document.
(See *Loading documents* on page 10.)
- 2 Press **Black Start** or **Color Start**.

Making multiple copies

You can make up to 99 copies.

- 1 Load your document.
- 2 Press **+** or **-** repeatedly until the number of copies you want appears (up to 99).
- 3 Press **Black Start** or **Color Start**.



Note

To sort the copies, press **▲** or **▼** to choose *Stack/Sort*. (See *Sorting copies using the ADF (DCP-540CN only)* on page 31.)

Stop copying

To stop copying, press **Stop/Exit**.

Copy options

You can change the copy settings from the default display. The LCD shows:

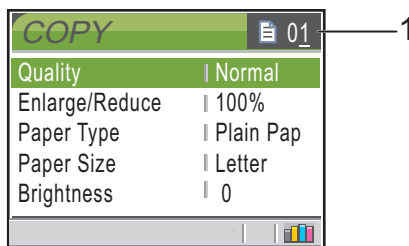

1 No of Copies

You can enter the number of copies you want by pressing **+** or **-** repeatedly.

Press **▲** or **▼** to scroll through the copy options menu.

- Quality (See page 29.)
- Enlarge/Reduce (See page 29.)
- Paper Type (See page 32.)
- Paper Size (See page 32.)
- Brightness (See page 31.)
- Contrast (See page 31.)
- Color Adjust (See page 32.)
- Stack/Sort (DCP-540CN only)
(See page 31.)
- Page Layout (See page 30.)
- Set New Default (See page 33.)
- Factory Reset (See page 33.)

When the option you want is highlighted, press **OK**.

You can change the copy settings temporarily for the next copy.

These settings are temporary, and the machine returns to its default settings 60 seconds after copying.

If you have finished choosing settings, press **Black Start** or **Color Start**.

If you want to choose more settings, press ▲ or ▼.



Note

You can save some of the settings that you use most often by setting them as default. These settings will stay until you change them again. (See *Setting your changes as new default* on page 33.)

Changing and quality

You can choose the copy quality. The factory setting is *Normal*.

Fast	Fast copy speed and lowest amount of ink used. Use this setting to save time (documents to be proof read, large documents or many copies).
Normal	Recommended setting for ordinary printouts. Good copy quality with adequate copy speed.
Best	Use this setting to copy precise images such as photographs. The highest resolution and slowest speed.

- 1 Load your document.
- 2 Enter the number of copies you want.
- 3 Press ▲ or ▼ to choose *Quality*. Press **OK**.
- 4 Press ▲ or ▼ to choose *Fast*, *Normal* or *Best*. Press **OK**.
- 5 If you do not want to change additional settings, press **Black Start** or **Color Start**.

Enlarging or reducing the image copied

You can choose an enlargement or reduction ratio.

- 1 Load your document.
- 2 Enter the number of copies you want.
- 3 Press ▲ or ▼ to choose *Enlarge/Reduce*. Press **OK**.

50%
69% A4→A5
78%
83%
93% A4→LTR
97% LTR→A4
100%*
104% EXE→LTR
142% A5→A4
186% 4"x6"→LTR
198% 4"x6"→A4
200%
Custom (25-400%)

- 4 Choose one of the options below:
 - Use ▲ or ▼ to select the enlargement or reduction ratio you want. Press **OK**.
 - Use ▲ or ▼ to select *Custom (25-400%)*. Press + or - to enter an enlargement or reduction ratio from 25% to 400%. Press **OK**.
- 5 If you do not want to change additional settings, press **Black Start** or **Color Start**.



Note

Page Layout Options are not available with *Enlarge/Reduce*.

Making N in 1 copies or a poster (page layout)

The N in 1 copy feature can help you save paper by letting you copy two or four pages onto one printed page.

You can also make a poster. When you use the poster feature your machine divides your document into sections, then enlarges the sections so you can assemble them into a poster. If you want to print a poster, use the scanner glass.



Note

- Make sure paper size is set to **Letter** or **A4**.
- If you are producing multiple color copies, N in 1 copy is not available.
- If **Brother Photo** or **Other Photo** has been chosen in the Paper Type setting for N in 1 copies, the machine will print the images as if **Plain paper** had been chosen.
- (P) means Portrait and (L) means Landscape.
- You can only make one poster copy at a time.

- 1 Load your document.
- 2 Enter the number of copies you want.
- 3 Press ▲ or ▼ to choose **Page Layout**. Press **OK**.
- 4 Press ▲ or ▼ to choose Off (1 in 1), 2 in 1 (P), 2 in 1 (L), 4 in 1 (P), 4 in 1 (L) or **Poster (3 × 3)**. Press **OK**.

- 5 If you do not want to change additional settings, press **Black Start** or **Color Start** to scan the page. If you are making a poster or placed the document in the ADF, the machine scans the pages and starts printing. **If you are using the scanner glass, go to 6.**
- 6 After the machine scans the page, press **+ (Yes)** to scan the next page.
- 7 Place the next page on the scanner glass. Press **OK**. Repeat 6 and 7 for each page of the layout.
- 8 After all the pages have been scanned, press **- (No)** to finish.

Place your document face down in the direction shown below.

■ 2 in 1 (P)



■ 2 in 1 (L)

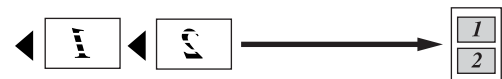

■ 4 in 1 (P)



■ 4 in 1 (L)



■ Poster (3 x 3)

You can make a poster size copy of a photograph.

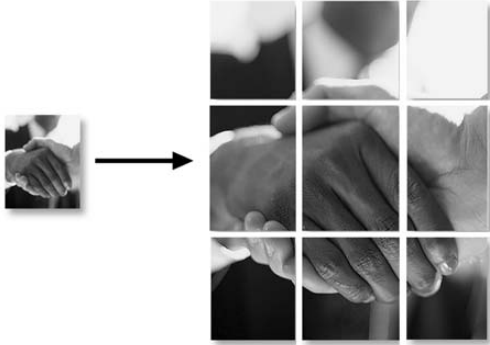

Sorting copies using the ADF (DCP-540CN only)

You can sort multiple copies. Pages will be stacked in reverse order.

- 1 Load your document.
- 2 Enter the number of copies you want.
- 3 Press ▲ or ▼ to choose *Stack/Sort*. Press **OK**.
- 4 Press ▲ or ▼ to choose *Sort*. Press **OK**.
- 5 If you do not want to change additional settings, press **Black Start** or **Color Start**.

Adjusting Brightness, Contrast and Color

Brightness

You can adjust the copy brightness to make copies darker or lighter.

- 1 Load your document.
- 2 Enter the number of copies you want.
- 3 Press ▲ or ▼ to choose *Brightness*. Press **OK**.
- 4 Press ▲ to make a lighter copy or press ▼ to make a darker copy. Press **OK**.
- 5 If you do not want to change additional settings, press **Black Start** or **Color Start**.

Contrast

You can adjust the copy contrast to help an image look sharper and more vivid.

- 1 Load your document.
- 2 Enter the number of copies you want.
- 3 Press ▲ or ▼ to choose *Contrast*. Press **OK**.
- 4 Press ▲ to increase the contrast or press ▼ to decrease the contrast. Press **OK**.
- 5 If you do not want to change additional settings, press **Black Start** or **Color Start**.

Color Saturation

- 1 Load your document.
- 2 Enter the number of copies you want.
- 3 Press ▲ or ▼ to choose `Color Adjust.`
Press **OK**.
- 4 Press ▲ or ▼ to choose `Red, Green or Blue.`
Press **OK**.
- 5 Press ▲ to increase the color saturation, or press ▼ to decrease the color saturation.
Press **OK**.
- 6 Do one of the following:
 - If you want to change another color saturation, go to step 4.
 - If you want to change additional settings, press ▲ or ▼ to choose `Exit.`
Press **OK**.
 - If you do not want to change additional settings, press **Black Start** or **Color Start**.

Paper options

Paper Type

If you are copying on special paper, set the machine for the type of paper you are using to get the best print quality.

- 1 Load your document.
- 2 Enter the number of copies you want.
- 3 Press ▲ or ▼ to choose `Paper Type.`
Press **OK**.
- 4 Press ▲ or ▼ to choose `Plain Paper, Inkjet Paper, Brother Photo, Other Photo or Transparency.`
Press **OK**.
- 5 If you do not want to change additional settings, press **Black Start** or **Color Start**.

Paper Size

If copying on paper other than Letter size, you will need to change the paper size setting.

You can copy only on Letter, Legal, A4, A5 or Photo Card [4 in. (W) × 6 in. (H) or 10 cm (W) × 15 cm (H)] paper.

- 1 Load your document.
- 2 Enter the number of copies you want.
- 3 Press ▲ or ▼ to choose `Paper Size.`
Press **OK**.
- 4 Press ▲ or ▼ to choose `Letter, Legal, A4, A5 or 4" x 6".`
Press **OK**.
- 5 If you do not want to change additional settings, press **Black Start** or **Color Start**.

Setting your changes as new default

You can save the copy settings for `Quality`, `Paper Type`, `Brightness`, `Contrast` and `Color Adjust` that you use most often by setting them as the default settings. These settings will stay until you change them again.

- 1 Press ▲ or ▼ to choose your new setting.
Press **OK**.
Repeat this step for each setting you want to change.
- 2 After changing the last setting, press ▲ or ▼ to choose `Set New Default`.
Press **OK**.
- 3 Press **+** to choose `Yes`.
- 4 Press **Stop/Exit**.

Restoring all the settings to factory settings

You can restore all the settings you have changed to the factory settings. These settings will stay until you change them again.

- 1 Press ▲ or ▼ to choose `Factory Reset`.
Press **OK**.
- 2 Press **+** to choose `Yes`.
- 3 Press **Stop/Exit**.



Walk-up Photo Printing

PhotoCapture Center®	36
PictBridge	47

PhotoCapture Center® Operations

Printing from a media card without a PC

Even if your machine is not connected to your computer, you can print photos directly from digital camera media. (See *Print Images* on page 38.)

Scanning to a media card without a PC

You can scan documents and save them directly to a media card. (See *Scan to Card* on page 45.)

Using PhotoCapture Center® from your computer

You can access the media card that is in the media drive (slot) of the machine from your PC.

(See *PhotoCapture Center®* for Windows® or *Remote Setup & PhotoCapture Center®* for Macintosh® in the Software User's Guide on the CD-ROM.)

Using media cards

Your Brother machine includes media drives (slots) for use with popular digital camera media: CompactFlash®, Memory Stick®, Memory Stick Pro™, SecureDigital™, MultiMediaCard™ and xD-Picture Card™.



CompactFlash®



Memory Stick®

Memory Stick Pro™



SecureDigital™

MultiMediaCard™



xD-Picture Card™

- miniSD™ can be used with a miniSD™ adapter.
- Memory Stick Duo™ can be used with a Memory Stick Duo™ adapter.
- Memory Stick Pro Duo™ can be used with a Memory Stick Pro Duo™ adapter.
- Adapters are not included with the machine. Contact a third party supplier for adapters.

The PhotoCapture Center® feature lets you print digital photos from your digital camera at high resolution to get photo quality printing.

Media card folder structure

To avoid errors, remember the following points:

- The DPOF file on the media card must be in a valid format. (See *DPOF printing* on page 40.)
- The image file extension must be .JPG (Other image file extensions like .JPEG, .TIF, .GIF and so on will not be recognized).
- Walk-up PhotoCapture Center® printing must be performed separately from PhotoCapture Center® operations using the PC. (Simultaneous operation is not available.)
- IBM Microdrive™ is not compatible with the machine.
- The machine can read up to 999 files (including the folder inside memory) on a media card.
- CompactFlash® Type II is not supported.
- This product supports xD-Picture Card™ Type M / Type H (Large Capacity).

Please be aware of the following:

- When printing the INDEX or IMAGE, the PhotoCapture Center® will print all the valid images, even if one or more images have been corrupted. A portion of the corrupted image may be printed.
- Your machine is designed to read media cards that have been formatted by a digital camera.

When a digital camera formats a media card it creates a special folder into which it copies image data. If you need to modify the image data stored on a media card with your PC, we recommend that you do not modify the folder structure created by the digital camera. When saving new or modified image files to the media card we also recommend you use the same folder your digital camera uses. If the data is not saved to the same folder, the machine may not be able to read the file or print the image.

Getting started

Firmly put the card into the proper slot.

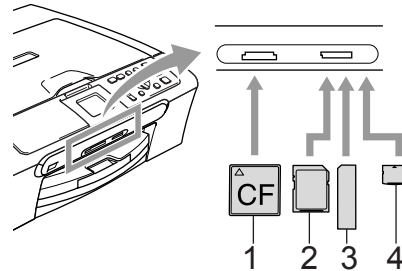

- 1 CompactFlash®
- 2 SecureDigital™, MultiMediaCard™
- 3 Memory Stick®, Memory Stick Pro™
- 4 xD-Picture Card™

PhotoCapture key lights:

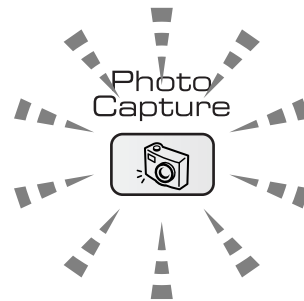

- **PhotoCapture** light is on, the media card is properly inserted.
- **PhotoCapture** light is off, the media card is not properly inserted.
- **PhotoCapture** light is blinking, the media card is being read or written to.

! CAUTION

DO NOT unplug the power cord or remove the media card from the media drive (slot) while the machine is reading or writing to the card (the **PhotoCapture** key is blinking). **You will lose your data or damage the card.**

The machine can only read one media card at a time so do not put more than one card in the slot.

Entering PhotoCapture mode

After you insert the media card, press the  (**PhotoCapture**) key to illuminate it in green and display the PhotoCapture options on the LCD.

The LCD shows:



Press ▲ or ▼ to scroll through the PhotoCapture key options.

- View Photo(s) (See page 38.)
- Print Index (See page 39.)
- Print All Photos (See page 39.)
- Print Photos (See page 40.)

Note

If your digital camera supports DPOF printing, see *DPOF printing* on page 40.

When the option you want is highlighted, press **OK**.

Print Images

View Photo(s)

You can preview your photos on the LCD before you print them. If your photos are large files there may be a delay before each photo is displayed on the LCD.

- 1 Make sure you have put the media card in the proper slot.
Press  (**PhotoCapture**).
- 2 Press ▲ or ▼ to choose View Photo(s).
Press **OK**.
- 3 Press ◀ or ▶ to choose your photo.
- 4 Press + or - repeatedly to enter the number of copies you want.
- 5 Repeat step 3 and step 4 until you have chosen all the photos.
- 6 After you have chosen all the photos, do one of the following:
 - Press **OK** and change the print settings. (See page 41.)
 - If you do not want to change any settings, press **Color Start** to print.

Print Index (Thumbnails)

The PhotoCapture Center® assigns numbers for images (such as No.1, No.2, No.3, and so on).



The PhotoCapture Center® does not recognize any other numbers or file names that your digital camera or PC has used to identify the pictures. You can print a thumbnail page (Index page with 6 or 5 images per line). This will show all the pictures on the media card.

- 1 Make sure you have put the media card in the proper slot.
Press  (**PhotoCapture**).
- 2 Press ▲ or ▼ to choose `Print Index`. Press **OK**.
- 3 Press ▲ or ▼ to choose `6 Images/Line Fast` or `5 Images/Line Photo`. Press **OK**.



5 Images/Line
Photo

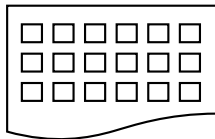

6 Images/Line
Fast

Print time for 5 Images/Line will be slower than 6 Images/Line, but the quality is better.

- 4 Press **Color Start** to print.

Print All Photos

You can print all the photos on your media card.

- 1 Make sure you have put the media card in the proper slot.
Press  (**PhotoCapture**).
- 2 Press ▲ or ▼ to choose `Print All Photos`. Press **OK**.
- 3 Press + or - repeatedly to enter the number of copies you want.
- 4 Do one of the following:
 - Change the print settings. (See page 41.)
 - If you do not want to change any settings, press **Color Start** to print.

Print Photos

Before you can print an individual image, you have to know the image number.

- 1 Make sure you have put the media card in the proper slot.
Press  (**PhotoCapture**).
- 2 Print the Index. (See *Print Index (Thumbnails)* on page 39.)
- 3 Press ▲ or ▼ to choose *Print Photos*.
Press **OK**.
- 4 Press + repeatedly to enter the image number that you want to print from the Index page (Thumbnails).
If you want to choose a two digit number, press ► to move the cursor to the next digit.
(For example, enter 1, ►, 6 to print image No.16.)
Press **OK**.
- 5 Repeat step 4 until you have entered all the image numbers that you want to print.



Note

- Press - to decrease the image number.
- You can enter all the numbers at one time by using the **OK** key for a comma. (For example, Enter 1, **OK**, 3, **OK**, 6 to print images No.1, No.3 and No.6.)

- 6 After you have chosen all the image numbers, press **OK** again.
- 7 Press + or - repeatedly to enter the number of copies you want. Press **OK**.
- 8 Do one of the following:
 - Change the print settings. (See page 41.)
 - If you do not want to change any settings, press **Color Start** to print.

DPOF printing

DPOF stands for Digital Print Order Format.

Major digital camera manufacturers (Canon Inc., Eastman Kodak Company, Fuji Photo Film Co. Ltd., Matsushita Electric Industrial Co. Ltd. and Sony Corporation) created this standard to make it easier to print images from a digital camera.

If your digital camera supports DPOF printing, you will be able to choose on the digital camera display the images and number of copies you want to print.

When the memory card (CompactFlash®, Memory Stick®, Memory Stick Pro™, SecureDigital™ MultiMediaCard™ or xD-Picture Card™) with DPOF information is put into your machine, you can print the chosen image easily.

- 1 Make sure you have put the media card into the proper slot.
Press  (**PhotoCapture**). The machine will ask you if you want to use DPOF setting.
- 2 Press + to choose *Yes*.
- 3 Do one of the following:
 - Change the print settings. (See page 41.)
 - If you do not want to change any settings, press **Color Start** to print.

PhotoCapture Center® print settings

You can change the print settings temporarily for the next printing.

These settings are temporary, and the machine returns to its default settings 180 seconds after printing.



Note

You can save the print settings you use most often by setting them as default. (See *Setting your changes as new default* on page 44.)

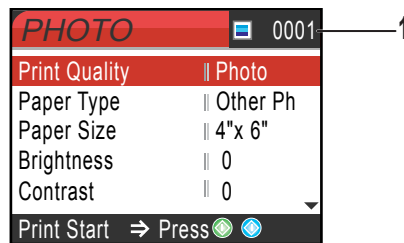

1 No of prints

(For View Photo(s))

You can see the total number of photos that will be printed.

(For Print All Photos, Print Photos)

You can see the number of copies of each photo that will be printed.

Menu Selections	Options1	Options2	Page
Print Quality	Normal/Photo		42
Paper Type	Plain Paper/Inkjet Paper/ Brother Photo/Other Photo		42
Paper Size	Letter/A4/4"x 6"/5"x 7"	(When A4 or Letter is selected) 4"x 3" 5"x 3.5" 6"x 4" 7"x 5" 8"x 6" Max. Size	42
Brightness			43
Contrast			43

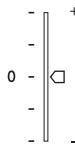
Menu Selections	Options1	Options2	Page
True2Life	On/Off White Balance / Sharpness / Color Density / Exit		43
Cropping	On/Off		44
Borderless	On/Off		44
Set New Default	Yes/No		44
Factory Reset	Yes/No		44

Print Quality

- 1 Press ▲ or ▼ to choose Print Quality.
Press **OK**.
- 2 Press ▲ or ▼ to choose Normal or Photo.
Press **OK**.
- 3 If you do not want to change additional settings, press **Color Start** to print.



Paper options

Paper Type

- 1 Press ▲ or ▼ to choose Paper Type.
Press **OK**.
- 2 Press ▲ or ▼ to choose the type of paper you are using, Plain Paper, Inkjet Paper, Brother Photo or Other Photo.
Press **OK**.
- 3 If you do not want to change additional settings, press **Color Start** to print.

Paper and print size

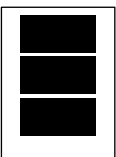
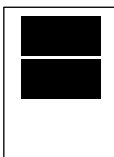
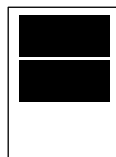
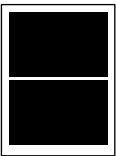
- 1 Press ▲ or ▼ to choose Paper Size.
Press **OK**.
- 2 Press ▲ or ▼ to choose the type of paper you are using, Letter, 4"× 6", 5"× 7" or A4.
Press **OK**.
- 3 If you chose Letter or A4, press ▲ or ▼ to choose the print size.
Press **OK**.

Example: Printed Position for Letter paper		
1 4"× 3"	2 5"× 3.5"	3 6"× 4"
		
4 7"× 5"	5 8"× 6"	6 Max. Size
		

- 4 If you do not want to change additional settings, press **Color Start** to print.

Adjusting Brightness, Contrast and Color

Brightness

- 1 Press ▲ or ▼ to choose **Brightness**. Press **OK**.
- 2 Press ▲ to make a lighter copy or press ▼ to make a darker copy. Press **OK**.
- 3 If you do not want to change additional settings, press **Color Start** to print.

Contrast

You can choose the contrast setting. More contrast will make an image look sharper and more vivid.

- 1 Press ▲ or ▼ to choose **Contrast**. Press **OK**.
- 2 Press ▲ to increase the contrast or press ▼ to decrease the contrast. Press **OK**.
- 3 If you do not want to change additional settings, press **Color Start** to print.

Color Enhancement (True2Life®)

You can turn on the color enhancement (True2Life®) feature to print more vivid images. Printing time will be slower.

- 1 Press ▲ or ▼ to choose **True2Life**. Press **OK**.
- 2 Do one of the following:
 - If you want to customize the **White Balance**, **Sharpness** or **Color Density**, press ◀ or ▶ to choose **On**, and then go to step 3.
 - If you do not want to customize, press ◀ or ▶ to choose **Off**. Press **OK** and then go to step 6.

- 3 Press ▲ or ▼ to choose **White Balance**, **Sharpness** or **Color Density**. Press **OK**.
- 4 Press ▲ or ▼ to adjust the degree of the setting. Press **OK**.
- 5 Do one of the following:
 - If you want to customize other color enhancement, press ▲ or ▼ to choose other option.
 - If you want to change other settings, press ▲ or ▼ to choose **Exit**, and then press **OK**.
- 6 If you do not want to change additional settings, press **Color Start** to print.



Note

• **White Balance**

This setting adjusts the hue of the white areas of an image. Lighting, camera settings and other influences will effect the appearance of white. The white areas of a picture may be slightly pink, yellow or some other color. By using this setting, you can correct that effect and bring the white areas back to pure white.

• **Sharpness**

This setting enhances the detail of an image, similar to adjusting the fine focus on a camera. If the image is not in true focus and you cannot see the fine details of the picture, then adjust the sharpness.

• **Color Density**

This setting adjusts the total amount of color in the image. You can increase or decrease the amount of color in an image to improve a washed out or weak picture.

Cropping

If your photo is too long or wide to fit the available space on your chosen layout, part of the image will automatically be cropped.

The factory setting is *On*. If you want to print the whole image, turn this setting to *Off*.

- 1 Press **▲** or **▼** to choose *Cropping*. Press **OK**.
- 2 Press **▲** or **▼** to choose *Off* (or *On*). Press **OK**.
- 3 If you do not want to change additional settings, press **Color Start** to print.

Cropping: *On*

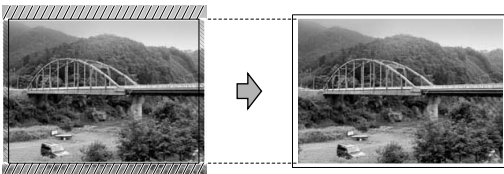

Cropping: *Off*

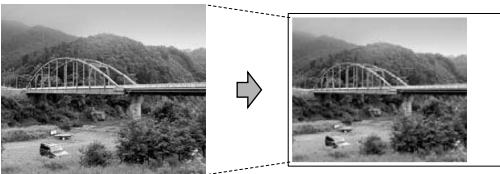

Borderless printing

This feature expands the printable area to the edges of the paper. Printing time will be slightly slower.

- 1 Press **▲** or **▼** to choose *Borderless*. Press **OK**.
- 2 Press **▲** or **▼** to choose *Off* (or *On*). Press **OK**.
- 3 If you do not want to change additional settings, press **Color Start** to print.

Setting your changes as new default

You can save the print settings you use most often by setting them as the default settings. These settings will stay until you change them again.

- 1 Press **▲** or **▼** to choose your new setting. Press **OK**. Repeat this step for each setting you want to change.
- 2 After changing the last setting, press **▲** or **▼** to choose *Set New Default*. Press **OK**.
- 3 Press **+** to choose *Yes*.
- 4 Press **Stop/Exit**.

Restoring all the settings to factory settings

You can restore all the settings you have changed to the factory settings. These settings will stay until you change them again.

- 1 Press **▲** or **▼** to choose *Factory Reset*. Press **OK**.
- 2 Press **+** to choose *Yes*.
- 3 Press **Stop/Exit**.

Scan to Card

Entering Scan mode

When you want to scan to card, press



The LCD shows:

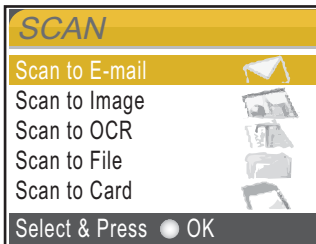

Press ▲ or ▼ to choose `Scan to Card`.

Press **OK**.

If you are not connected to your computer only the `Scan to Card` selection will appear on the LCD.

(See *Scanning for Windows®* or *Macintosh®* in the Software User's Guide for details about the other menu options.)

How to scan to card

You can scan black & white and color documents into a media card. Black & white documents will be stored in PDF (*.PDF) or TIFF file formats (*.TIF). Color documents may be stored in PDF (*.PDF) or JPEG (*.JPG) file formats. The factory setting is 150 dpi Color and the default file format is PDF. File names default to the current date that you set using the control panel keys. (For details, see Quick Setup Guide.) For example, the fifth image scanned on July 1, 2006 would be named 07010506.PDF. You can change the color and quality.

Quality	Selectable File Format
150dpi Color	JPEG / PDF
300dpi Color	JPEG / PDF
600dpi Color	JPEG / PDF
200x100dpi B/W	TIFF / PDF
200dpi B/W	TIFF / PDF

- 1 Insert a CompactFlash®, Memory Stick®, Memory Stick Pro™, SecureDigital™, MultiMediaCard™ or xD-Picture Card™ into your machine.

! WARNING

Do not take out the media card while **PhotoCapture** is blinking to avoid damaging the card or data stored on the card.

- 2 Load your document.
- 3 Press  (**Scan**).
- 4 Press ▲ or ▼ to select `Scan to Card`, choose one of the options below:
 - To change the quality press **OK** and go to step 5.
 - To start scanning press **Black Start** or **Color Start**.
- 5 Press ▲ or ▼ to select the quality, choose one of the options below:
 - To change the file type, press **OK** and go to step 6.
 - To start scanning press **Black Start** or **Color Start**.
- 6 Press ▲ or ▼ to select the file type, press **OK**.
- 7 Press **Black Start** or **Color Start**.

Understanding the Error Messages

Once you are familiar with the types of errors that can occur while you are using the PhotoCapture Center[®], you can easily identify and troubleshoot any problems.

■ Media Error

This message will appear if you put in a media card that is either bad or not formatted, or when there is a problem with the media drive. To clear this error, take out the media card.

■ No File

This message will appear if you try to access a media card in the drive (slot) that does not contain a .JPG file.

■ Out of Memory

This message will appear if you are working with images that are too large for the machine's memory.



Your Brother machine supports the PictBridge standard, allowing you to connect to and print photos directly from any PictBridge compatible digital camera.

Before Using PictBridge

PictBridge requirements

To avoid errors, remember the following points:

- The machine and the digital camera must be connected using a suitable USB cable.
- The image file extension must be .JPG (other image file extensions like .JPEG, .TIF, .GIF and so on will not be recognized).
- PhotoCapture Center operations are not available when using the PictBridge feature.

Using PictBridge

Setting your digital camera

Make sure your camera is in PictBridge mode. The following PictBridge settings may be available from the LCD of your PictBridge compatible camera.

Depending on your camera some of these settings may not be available.

Camera Menu Selections	Options
Paper Size	Letter, A4, 4"×6", Printer Settings (Default setting) ²
Paper Type	Plain Paper, Glossy Paper, Inkjet Paper, Printer Settings (Default setting) ²
Layout	Borderless: On, Borderless: Off, Printer Settings (Default setting) ²
DPOF setting ¹	-
Print Quality	Normal, Fine, Printer Settings (Default setting) ²
Color Enhancement	On, Off, Printer Settings (Default setting) ²

¹ See *DPOF printing* on page 48 for more details.

² If your camera is set to use the Printer Settings (Default setting), the machine will print your photo using the settings below.

Settings	Options
Paper Size	4"×6"
Paper Type	Glossy Paper
Layout	Borderless: On
Print Quality	Fine
Color Enhancement	Off

- The names and availability of each setting depends on the specification of your camera.

Please refer to the documentation supplied with your camera for more detailed information on changing PictBridge settings.

Printing Images

- 1 Make sure that your camera is turned off. Connect your camera to the PictBridge port (1) on the machine using the USB cable.

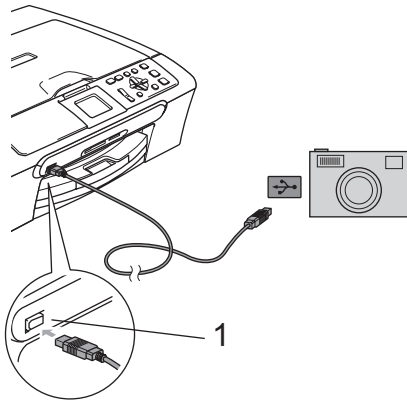

1 PictBridge port



Note

Remove any media cards from the machine before connecting the digital camera.

- 2 Turn on the camera. When the machine has recognized the camera, the LCD shows *Camera Connected*. When the machine starts printing a photo, the LCD will show *Printing*.



WARNING

To prevent damage to your machine, do not connect any device other than a PictBridge compatible camera to the PictBridge port.

DPOF printing

DPOF stands for Digital Print Order Format.

Major digital camera manufacturers (Canon Inc., Eastman Kodak Company, Fuji Photo Film Co. Ltd., Matsushita Electric Industrial Co. Ltd. and Sony Corporation) created this standard to make it easier to print images from a digital camera.

If your digital camera supports DPOF printing, you will be able to choose on the digital camera display the images and number of copies you want to print.

Understanding the Error Messages

Once you are familiar with the types of errors that can occur while you are using the PictBridge, you can easily identify and troubleshoot any problems.

■ Out of Memory

This message will appear if you are working with images that are too large for the machine's memory.

■ Wrong USB device

This message will appear if you connect a non-PictBridge compatible or broken device to the PictBridge port. To clear the error, unplug the device from the PictBridge port, then press **On/Off** to turn the machine off and then on again.

For more detailed solutions see *Error messages* on page 67.



Software

Software and Network features

52

7

Software and Network features

The CD-ROM includes the Software User's Guide and Network User's Guide (DCP-540CN only) for features available when connected to a computer (for example, printing and scanning). The guide has easy to use links that, when clicked, will take you directly to a particular section.

You can find information on these features:

- Printing
- Scanning
- ControlCenter3 (for Windows®)
- ControlCenter2 (for Macintosh®)
- PhotoCapture Center®
- Network Printing (DCP-540CN only)
- Network Scanning (DCP-540CN only)

How to read the HTML User's Guide

This is a quick reference for using the HTML User's Guide.

(For Windows®)



Note

If you have not installed the software, see *Viewing Documentation* on page 2.

- 1 From the **Start menu**, point to **Brother**, from the programs group, then click **User's Guide**.
- 2 Click **SOFTWARE USER'S GUIDE** (or **NETWORK USER'S GUIDE**) from the top menu.



- 3 Click the heading you would like to view from the list at the left of the window.

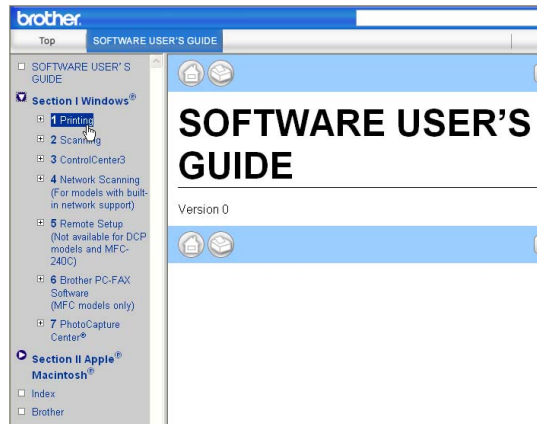

(For Macintosh®)

- 1 Make sure your Macintosh® is turned on. Insert the Brother CD-ROM into your CD-ROM drive. The following window will appear.
- 2 Double-click the **Documentation** icon.
- 3 Double-click your language folder, and then double-click the top page file.
- 4 Click **SOFTWARE USER'S GUIDE** (or **NETWORK USER'S GUIDE**) in the top menu, and then click the heading you would like to read from the list at the left of the window.

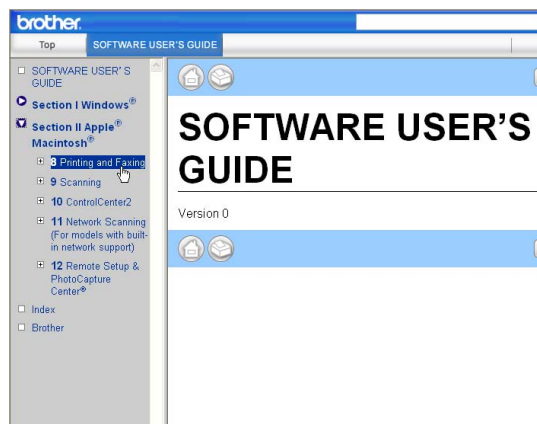



Appendixes

Safety and Legal	54
Troubleshooting and Routine Maintenance	63
Menu and Features	81
Specifications	89
Glossary	99

A

Safety and Legal

Choosing a location

Put your machine on a flat, stable surface that is free of vibration and shocks, such as a desk. Put the machine near a standard AC power outlet. Choose a location where the temperature remains between 50° F and 95° F (10° and 35° C).

! CAUTION

- Avoid placing your machine in a high-traffic area.
- Avoid placing your machine on carpet.
- DO NOT put the machine near heaters, air conditioners, refrigerators medical equipment, chemicals or water.
- DO NOT expose the machine to direct sunlight, excessive heat, moisture, or dust.
- DO NOT connect your machine to electrical outlets controlled by wall switches or automatic timers.
- Disruption of power can wipe out information in the machine's memory.
- Do not connect your machine to electrical outlets on the same circuit as large appliances or other equipment that might disrupt the power supply.
- Avoid interference sources, such as speakers or the base units of non-Brother cordless phones.

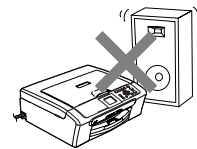
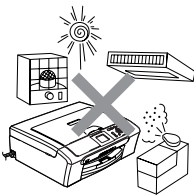

To use the machine safely

Please keep these instructions for later reference and read them before attempting any maintenance.

WARNING



There are high voltage electrodes inside the machine. Before you clean the inside of the machine, make sure you have unplugged the power cord from the AC power outlet. Doing this will prevent an electrical shock.

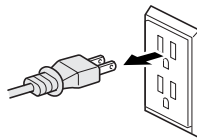

DO NOT handle the plug with wet hands. Doing this may cause an electrical shock.

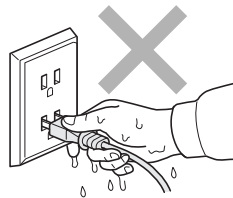

Always make sure the plug is fully inserted.



DO NOT pull in the middle of the AC power cord. Doing this may cause an electrical shock.



DO NOT put your hands on the edge of the machine under the document cover or the scanner cover. Doing this may cause injury.

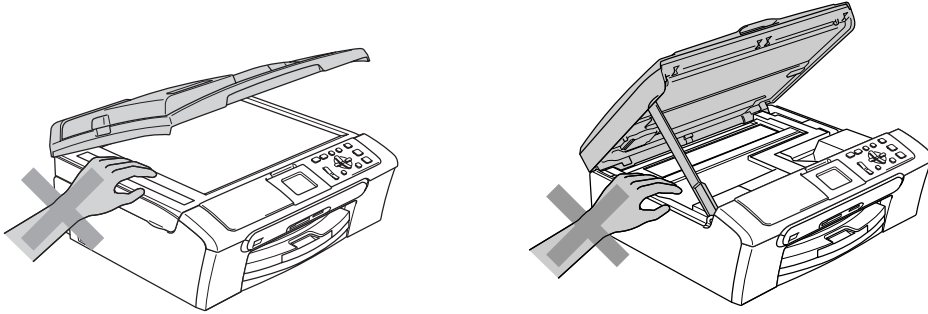

DO NOT put your hands on the edge of the paper tray under the output paper tray cover. Doing this may cause injury.

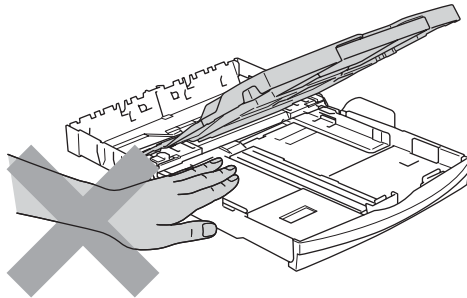

DO NOT touch the paper feed roller. Doing this may cause injury.

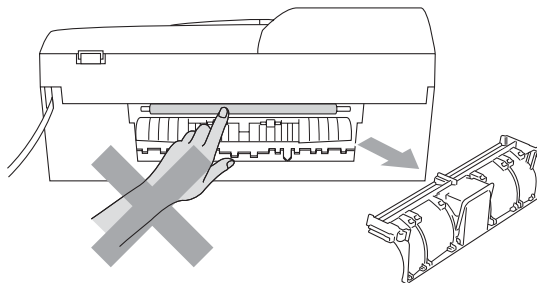



DO NOT touch the area shaded in the illustration. Doing this may cause injury.

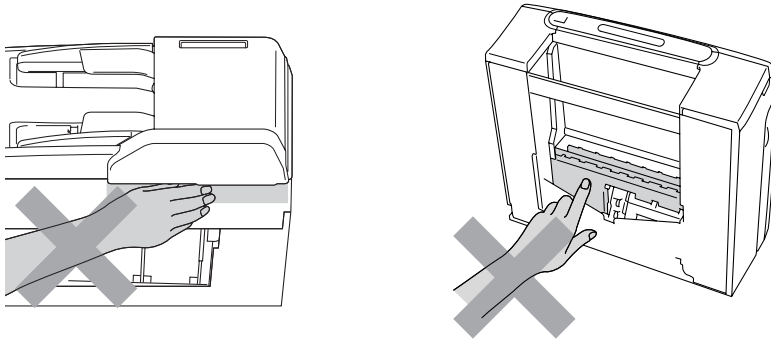

When moving the machine you must lift it from the base, by placing a hand at each side of the unit as shown in the illustration. Do not carry the machine by holding the scanner cover.

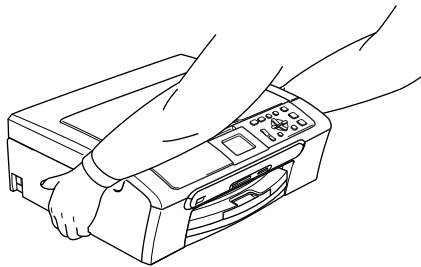

If the machine becomes hot, releases smoke, or generates any strong smells, immediately turn off the power switch and unplug the machine from the AC power outlet. Call Brother Customer Service. (See *Brother numbers* on page i.)

If metal objects, water or other liquids get inside the machine, immediately turn off the power switch and unplug the machine from the AC power outlet. Call Brother Customer Service. (See *Brother numbers* on page i.)

WARNING

- This product must be installed near an AC power outlet that is easily accessible. In case of an emergency, you must unplug the power cord from the AC power outlet to shut off the power completely.
- Always make sure the plug is fully inserted.
- To reduce the risk of shock or fire, use only a No. 26 AWG or larger telecommunication line cord.

CAUTION

Lightning and power surges can damage this product! We recommend that you use a quality surge protection device on the AC power line or unplug the cords during a lightning storm.

Important safety instructions

- 1 Read all of these instructions.
- 2 Save them for later reference.
- 3 Follow all warnings and instructions marked on the product.
- 4 Unplug this product from the wall outlet before cleaning the inside of the machine. Do not use liquid or aerosol cleaners. Use a damp cloth for cleaning.
- 5 Do not use this product near water.
- 6 Do not place this product on an unstable cart, stand, or table. The product may fall, causing serious damage to the product.
- 7 Slots and openings in the cabinet and the back or bottom are provided for ventilation. To ensure reliable operation of the product and to protect it from overheating, these openings must not be blocked or covered. The openings should never be blocked by placing the product on a bed, sofa, rug, or other similar surface. This product should never be placed near or over a radiator or heater. This product should never be placed in a built-in installation unless proper ventilation is provided.
- 8 This product should be operated from the type of power source indicated on the label. If you are not sure of the type of power available, call your dealer or local power company.
- 9 Use only the power cord supplied with this machine.
- 10 Do not allow anything to rest on the power cord. Do not place this product where people can walk on the cord.
- 11 If an extension cord is used with this product, make sure that the total ampere ratings of the products plugged into the extension cord do not exceed the extension cord ampere rating. Also, make sure that the total of all products plugged into the AC power outlet does not exceed 15 amperes (USA only).

- 12 Do not place anything in front of the machine that will block printing. Do not place anything in the path of printing.
- 13 Wait until pages have exited the machine before picking them up.
- 14 Never push objects of any kind into this product through cabinet slots, since they may touch dangerous voltage points or short out parts resulting in the risk of fire or electric shock. Never spill liquid of any kind on the product. Do not attempt to service this product yourself because opening or removing covers may expose you to dangerous voltage points and other risks and may void your warranty. Refer all servicing to a Brother Authorized Service Center. For the location of your nearest Brother Authorized Service Center, please call the following:
In USA: 1-800-284-4357
In Canada: 1-877-BROTHER
- 15 Unplug this product from the AC power outlet and refer all servicing to Brother Authorized Service Personnel under the following conditions:
 - When the power cord is damaged or frayed.
 - If liquid has been spilled into the product.
 - If the product has been exposed to rain or water.
 - If the product does not operate normally when the operating instructions are followed, adjust only those controls that are covered by the operating instructions. Improper adjustment of other controls may result in damage and will often require extensive work by a qualified technician to restore the product to normal operation.
 - If the product has been dropped or the cabinet has been damaged.
 - If the product exhibits a distinct change in performance, indicating a need for service.
- 16 To protect your product against power surges, we recommend the use of a power protection device (Surge Protector).
- 17 To reduce the risk of fire, electric shock and injury to people, note the following:
 - Do not use this product near appliances that use water, a swimming pool, or in a wet basement.
 - Do not use the machine during an electrical storm (there is the remote possibility of an electrical shock) or to report a gas leak in the vicinity of the leak.

Federal Communications Commission (FCC) Declaration of Conformity (USA only)

Responsible Party: Brother International Corporation
100 Somerset Corporate Boulevard
Bridgewater, NJ 08807-0911
USA
TEL: (908) 704-1700

declares, that the products

Product Name: DCP-330C and DCP-540CN

comply with Part 15 of the FCC Rules. Operation is subject to the following two conditions: (1) This device may not cause harmful interference, and (2) this device must accept any interference received, including interference that may cause undesired operation.

This equipment has been tested and found to comply with the limits for a Class B digital device, pursuant to Part 15 of the FCC Rules. These limits are designed to provide reasonable protection against harmful interference in a residential installation. This equipment generates, uses, and can radiate radio frequency energy and, if not installed and used in accordance with the instructions, may cause harmful interference to radio communications. However, there is no guarantee that interference will not occur in a particular installation. If this equipment does cause harmful interference to radio or television reception, which can be determined by turning the equipment off and on, the user is encouraged to try to correct the interference by one or more of the following measures:

- Reorient or relocate the receiving antenna.
- Increase the separation between the equipment and receiver.
- Connect the equipment into an outlet on a circuit different from that to which the receiver is connected.
- Call the dealer or an experienced radio/TV technician for help.



WARNING

For protection against the risk of electrical shock, always disconnect all cables from the wall outlet before servicing, modifying or installing the equipment.

Brother cannot accept any financial or other responsibilities that may be the result of your use of this information, including direct, special or consequential damages. There are no warranties extended or granted by this document.

This machine has been certified to comply with FCC standards, which are applied to the USA only.

IMPORTANT

Changes or modifications not expressly approved by Brother Industries, Ltd. could void the user's authority to operate the equipment.

Industry Canada Compliance Statement (Canada only)

This Class B digital apparatus complies with Canadian ICES-003.

Cet appareil numérique de la classe B est conforme à la norme NMB-003 du Canada.

LAN connection (DCP-540CN only)

 **CAUTION**

DO NOT connect this product to a LAN connection that is subject to over-voltages.

Legal limitations for copying

It is offence to make color reproductions of certain instruments with the fraudulent intension. This memorandum is intended to be a guide rather than a complete listing of every possible prohibition. In case of doubt, we suggest that you check with counsel as to any particular questionable documents.

The following documents issued by the United States/Canadian Government or any of its Agencies may not be copied:

- Money
- Bonds or other certificates of indebtedness
- Certificates of Deposit
- Internal Revenue Stamps (canceled or uncanceled)
- Selective Service or draft papers
- Passports
- United States/Canadian Postage Stamps (canceled or uncanceled)
- Food Stamps
- Immigration Papers
- Checks or drafts drawn by Governmental agencies
- Identifying badges or insignias

Copyrighted works cannot be copied. Sections of a copyrighted work can be copied for 'fair use.' Multiple copies would indicate improper use.

Works of art should be considered the equivalent of copyrighted works.

Licenses and Certificates of Title to motor vehicles may not be copied under certain state/provincial laws.

Trademarks

The Brother logo is a registered trademark of Brother Industries, Ltd.

Brother is a registered trademark of Brother Industries, Ltd.

Multi-Function Link is a registered trademark of Brother International Corporation.

© 2006 Brother Industries, Ltd. All rights reserved.

Windows and Microsoft are registered trademarks of Microsoft in the U.S. and other countries.

Macintosh and TrueType are registered trademarks of Apple Computer, Inc.

PaperPort is a registered trademarks of ScanSoft, Inc.

Presto! PageManager is a registered trademark of NewSoft Technology Corporation.

Microdrive is a trademark of International Business Machine Corporation.

CompactFlash is a registered trademark of SanDisk Corporation.

Memory Stick is a registered trademark of Sony Corporation.

SecureDigital is a trademark of Matsushita Electric Industrial Co. Ltd., SanDisk Corporation and Toshiba Corporation.

SanDisk is a licensee of the SD and miniSD trademarks.

MultiMediaCard is a trademark of Infineon Technologies and licensed to the MultiMediaCard Association.

xD-Picture Card is a trademark of Fujifilm Co. Ltd., Toshiba Corporation and Olympus Optical Co. Ltd.

PictBridge is a trademark.

Memory Stick Pro, Memory Stick Pro Duo, Memory Stick Duo and MagicGate are trademarks of Sony Corporation.

Each company whose software title is mentioned in this manual has a Software License Agreement specific to its proprietary programs.

All other brand and product names mentioned in this User's Guide, the Software User's Guide and the Network User's Guide (DCP-540CN only) are registered trademarks of their respective companies.

B

Troubleshooting and Routine Maintenance

Troubleshooting

IMPORTANT

For technical help, you must call the country where you bought the machine. Calls must be made **from within** that country.

If you think there is a problem with your machine, check the chart below and follow the troubleshooting tips.

Most problems can be easily resolved by yourself. If you need additional help, the Brother Solutions Center offers the latest FAQs and troubleshooting tips. Visit us at <http://solutions.brother.com>.

If you are having difficulty with your machine

Printing

Difficulty	Suggestions
No printout	Check the interface cable on both the machine and your computer. (See the <i>Quick Setup Guide</i> .)
	Check that the machine is plugged in and that the On/Off key is on.
	One or more ink cartridges are empty. (See <i>Replacing the ink cartridges</i> on page 72.)
	Check to see if the LCD is showing an error message. (See <i>Error messages</i> on page 67.)
	Check that the correct printer driver has been installed and chosen.
	Make sure that the machine is online. Click Start and then Printers and Faxes . Right-click and choose Brother DCP-XXXX (where XXXX is your model name), and make sure that Use Printer Offline is unchecked.
Poor print quality	Check the print quality. (See <i>Checking the print quality</i> on page 77.)
	Make sure that the Media Type setting in the printer driver or the Paper Type setting in the machine's menu matches the type of paper you are using. (See <i>Printing for Windows</i> [®] or <i>Printing and Faxing for Macintosh</i> [®] in the Software User's Guide on the CD-ROM.)
	Make sure that your ink cartridges are fresh. The following may cause ink to clog: <ul style="list-style-type: none"> ■ The expiration date written on the cartridge package has passed. (Cartridges stay usable for up to two years if kept in their original packaging.) ■ The ink cartridge was in your machine over six months. ■ The ink cartridge may not have been stored properly before use.
	Try using the recommended types of paper. (See <i>Acceptable paper and other media</i> on page 12.)
	The recommended environment for your machine is between 68° F to 91° F (20° C to 33° C).

Printing (Continued)

Difficulty	Suggestions
White horizontal lines appear in text or graphics.	Clean the print head. (See <i>Cleaning the print head</i> on page 76.)
	Try using the recommended types of paper. (See <i>Acceptable paper and other media</i> on page 12.)
	If you want to print on Photo 4"×6" or Photo L 3.5"×5" paper, make sure you use the photo bypass tray. (See <i>Loading photo paper</i> on page 20.)
The machine prints blank pages.	Clean the print head. (See <i>Cleaning the print head</i> on page 76.)
Characters and lines are stacked.	Check the printing alignment. (See <i>Checking the print alignment</i> on page 78.)
Printed text or images are skewed.	Make sure the paper is loaded properly in the paper tray and the paper side guide is adjusted correctly. (See <i>Loading paper and other media</i> on page 16.)
	Make sure the Jam Clear Cover is set properly.
Smudged stain at the top center of the printed page.	Make sure the paper is not too thick or curled. (See <i>Acceptable paper and other media</i> on page 12.)
Printing appears dirty or ink seems to run.	Make sure you are using the proper types of paper. (See <i>Acceptable paper and other media</i> on page 12.) Don't handle the paper until the ink is dry.
Stains appear on the reverse side or at the bottom of the page.	Make sure the printer platen is not dirty with ink. (See <i>Cleaning the machine printer platen</i> on page 75.)
	Make sure you are using the paper support flap. (See <i>Loading paper and other media</i> on page 16.)
There are some dense lines.	Check Reverse Order in the Basic tab of the printer driver.
The printouts are wrinkled.	In the printer driver Basic tab, click Settings , and uncheck Bi-Directional Printing .
Cannot perform '2 in 1 or 4 in 1' printing.	Check that the paper size setting in the application and in the printer driver are the same.
Print speed is too slow.	Try changing the printer driver setting. The highest resolution needs longer data processing, sending and printing time. Try the other quality settings in the printer driver Basic tab. Also, click the Settings tab, and make sure you uncheck the Color Enhancement (True2Life®) .
	Turn the borderless feature off. Borderless printing is slower than normal printing. (See <i>Printing for Windows®</i> or <i>Printing and Faxing for Macintosh®</i> in the Software User's Guide on the CD-ROM.)
True2Life® is not working properly.	If the image data is not full color in your application (such as 256 color), True2Life® will not work. Use at least 24 bit color data with the True2Life® feature.
Machine feeds multiple pages.	Make sure the paper is loaded properly in the paper tray. (See <i>Loading paper and other media</i> on page 16.)
	Check that more than two types of paper are not loaded in the paper tray at any one time.
Printed pages are not stacked neatly.	Make sure you are using the paper support flap. (See <i>Loading paper and other media</i> on page 16.)
Printed pages double feed and cause a paper jam.	Make sure you pull out the paper support until it clicks and unfold the paper support flap.
Machine does not print from Paint Brush.	Try setting the Display setting to '256 colors.'
Machine does not print from Adobe Illustrator.	Try to reduce the print resolution. (See <i>Printing for Windows®</i> or <i>Printing and Faxing for Macintosh®</i> in the Software User's Guide on the CD-ROM.)

Copying Difficulties

Difficulty	Suggestions
Vertical streaks appear in copies.	If you see vertical streaks on copies, clean the scanner. (See <i>Cleaning the scanner</i> on page 75.)
Poor copy results when using the ADF. (DCP-540CN only)	Try using the scanner glass. (See <i>Using the scanner glass</i> on page 11.)

Scanning Difficulties

Difficulty	Suggestions
TWAIN/WIA errors appear while scanning.	Make sure the Brother TWAIN/WIA driver is chosen as the primary source. In PaperPort® SE with OCR, click File, Scan and choose the Brother TWAIN/WIA driver.
Poor scanning results when using the ADF.	Try using the scanner glass. (See <i>Using the scanner glass</i> on page 11.)

Software Difficulties

Difficulty	Suggestions
Cannot install software or print.	Run the Repair MFL-Pro Suite program on the CD-ROM. This program will repair and reinstall the software.
'Device Busy'	Make sure the machine is not showing an error message on the LCD.

PhotoCapture Center® Difficulties

Difficulty	Suggestions
Removable Disk does not work properly.	<ol style="list-style-type: none"> 1 Have you installed the Windows® 2000 update? If not, do the following: <ol style="list-style-type: none"> 1) Unplug the USB cable. 2) Install the Windows® 2000 update, and see the Quick Setup Guide. After the installation the PC will be automatically restarted. 3) Wait about 1 minute after you restart the PC, and then connect the USB cable. 2 Take out the media card and put it back in again. 3 If you have tried 'Eject' from within Windows®, take out the media card before you continue. 4 If an error message appears when you try to eject the media card, it means the card is being accessed. Wait a while and then try again. 5 If all of the above do not work, turn off your PC and machine, and then turn them on again. (You will have to unplug the power cord of the machine to turn it off.)
Cannot access Removable Disk from Desktop icon.	Make sure you have put the media card into the media slot.

Network Difficulties

Difficulty	Suggestions
Cannot print over the Network.	<p>Make sure that your machine is powered on and is online and in Ready mode. Print a Network Configuration list (see <i>Printing Reports</i> on page 9) and check the current Network settings printed in this list. Reconnect the LAN cable to the hub to verify that the cabling and network connections are good. If possible, try connecting the machine to a different port on your hub using a different cable. If the connections are good, the machine shows LAN Active for 2 seconds.</p> <p>(If you are having Network problems, see the <i>Network User's Guide</i> on the CD-ROM for more information.)</p>
The network scanning feature does not work.	<p>(For Windows® users only) Firewall setting on your PC may be rejecting the necessary network connection. Follow the instructions below to configure the Firewall. If you are using a personal Firewall software, see the User's Guide for your software or contact the software manufacturer.</p> <p><Windows® XP SP2 users></p> <ol style="list-style-type: none"> 1 Click the Start button, Settings, Control Panel and then Windows Firewall. Make sure that Windows Firewall on the Basic tab is set to On. 2 Click the Exceptions tab and Add port button. 3 Enter any name, port number (54295 for network scanning), choose UDP and click OK. 4 Make sure if the new setting is added and is checked, and then click OK. <p>For Windows® XP SP1 user's, please visit the Brother Solutions Center.</p>
Your computer cannot find your machine.	<p><Windows® users></p> <p>Firewall setting on you PC may be rejecting the necessary network connection. For detail, see the instruction above.</p> <p><Macintosh® users></p> <p>Re-select your machine in the DeviceSelector application located in Macintosh HD/Library/Printers/Brother/Utilities or from the model of ControlCenter2.</p>

Error messages

As with any sophisticated office product, errors may occur. If this happens, your machine identifies the error and shows an error message. The most common error messages are shown below.

You can correct most errors by yourself. If you need more help, the Brother Solutions Center offers the latest FAQs and troubleshooting tips.

Visit us at <http://solutions.brother.com>.

Error Message	Cause	Action
Cover is Open	The scanner cover is not closed completely.	Lift the scanner cover and then close it again.
	The ink cartridge cover is not completely closed.	Firmly close the ink cartridge cover until it clicks.
Data Remaining	Print data is left in the machine's memory.	Re-start printing from your computer.
	Print data is left in the machine's memory. The USB cable was unplugged while the computer was sending the data to the machine.	Press Stop/Exit . The machine will cancel the job and clear it from the memory. Try to print again.
Document Jam	The document was not inserted or fed properly, or the document scanned from the ADF was too long.	See <i>Using the ADF (DCP-540CN only)</i> on page 10. See <i>Document jam (DCP-540CN only)</i> on page 69.
High Temperature	The print head is too warm.	Allow the machine to cool down.
Ink Empty	One or more of the ink cartridges is empty. The machine will stop all print operations.	Replace the ink cartridges. (See <i>Replacing the ink cartridges</i> on page 72.)
Low Temperature	The print head is too cold.	Allow the machine to warm up.
Media Error	The media card is either corrupted, improperly formatted, or there is a problem with the media card.	Put the card firmly into the slot again to make sure it is in the correct position. If the error remains, check the media drive by putting in another media card that you know is working.
Near Empty	One or more of the ink cartridges are running out of ink.	Order a new ink cartridge. (See <i>Ordering accessories and supplies</i> on page ii.)
No Cartridge	An ink cartridge is not installed properly.	Take out the ink cartridge and put it in again seating it properly. (See <i>Replacing the ink cartridges</i> on page 72.)
No File	The media card in the media drive does not contain a .JPG file.	Put the correct media card into the slot again.

Error Message	Cause	Action
No Paper Fed	The machine is out of paper or paper is not properly loaded in the paper tray.	Do one of the following: <ul style="list-style-type: none"> ■ Refill the paper in the paper tray, and then press Black Start or Color Start. ■ Remove the paper and load it again and then press Black Start or Color Start.
	The paper is jammed in the machine.	See <i>Printer jam or paper jam</i> on page 70.
Out of Memory	The machine's memory is full.	Printing operation in progress Reduce print resolution. (For details, see <i>Printing for Windows®</i> or <i>Printing and Faxing for Macintosh®</i> in the Software User's Guide on the CD-ROM.)
Paper Jam	Paper is jammed in the machine.	Remove the Jam Clear Cover (at the back of the machine) and pull out the jammed paper. See <i>Printer jam or paper jam</i> on page 70.
Unable to Change XX Unable to Clean XX Unable to Init. XX Unable to Print XX Unable to Scan XX	The machine has a mechanical problem.	Disconnect the machine from the power for several minutes, then reconnect it.
Wrong USB device	A non-PictBridge compatible or broken device has been connected to the PictBridge port.	Unplug the device from the PictBridge port, then press On/Off to turn the machine off and then on again.

Document jam (DCP-540CN only)

Documents can jam if they are not inserted or fed properly, or if they are too long. Follow the steps below to clear a document jam.

Document is jammed in the top of the ADF unit

- 1 Take out any paper from the ADF that is not jammed.
- 2 Open the ADF cover.
- 3 Pull the jammed document up and to the left.

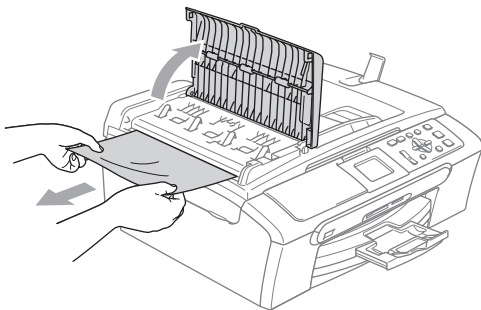

- 4 Close the ADF cover.
- 5 Press **Stop/Exit**.



Note

To avoid document jams close the ADF cover properly by pressing it down in the center.

Document is jammed inside the ADF unit

- 1 Take out any paper from the ADF that is not jammed.
- 2 Lift the document cover.
- 3 Pull the jammed document out to the left.

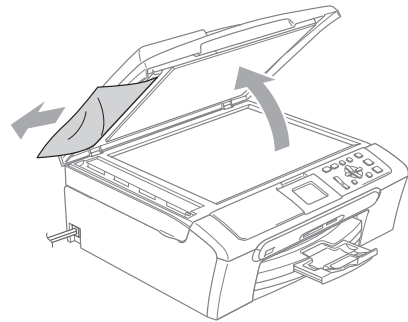

- 4 Close the document cover.
- 5 Press **Stop/Exit**.

Printer jam or paper jam

Take out the jammed paper depending on where it is jammed in the machine.

- 1 Pull the paper tray (1) out of the machine.

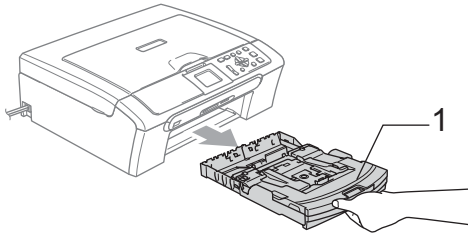

- 2 Pull out the jammed paper (1).

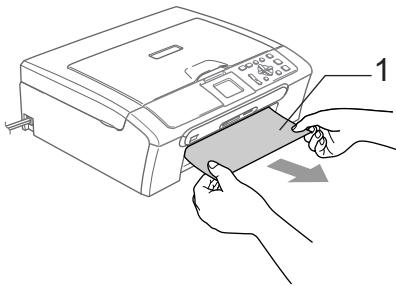

- 3 Reset the machine by lifting the scanner cover from the front of the machine and then closing it.

- If you cannot remove the jammed paper from the front side, or the error message still appears on the LCD after you remove the jammed paper, please go to the next step.

- 4 Remove the Jam Clear Cover (1) from the back of the machine. Pull the jammed paper out of the machine.

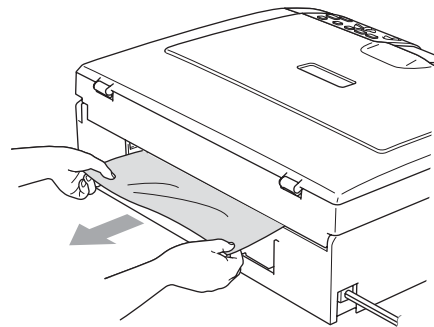
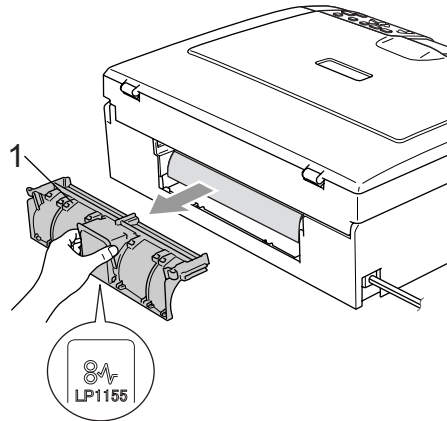

- 5 Put the Jam Clear Cover back on. Make sure the cover is set properly.

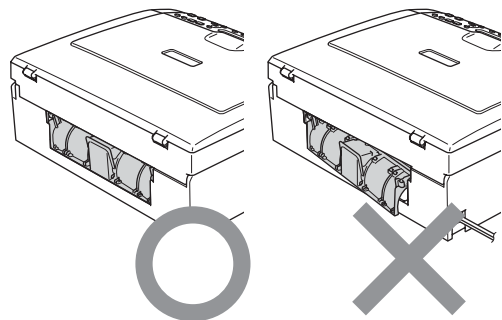

- 6 Lift the scanner cover (1) from the front side of the machine until it locks securely into the open position. Make sure that there is no jammed paper left in the corners of the machine.

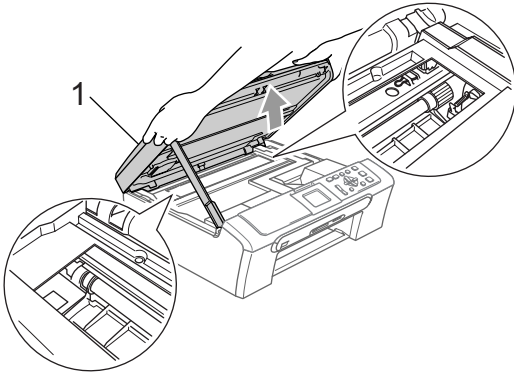

- Note**
If the paper is jammed under the print head, unplug the machine from the power source, and then move the print head to take out the paper.

- 7 Lift the scanner cover to release the lock (1). Gently push the scanner cover support down (2) and close the scanner cover (3).

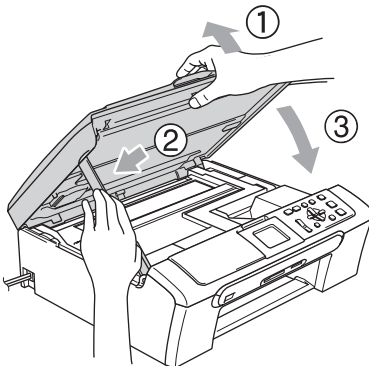

- 8 Push the paper tray firmly back into the machine.

- Note**
Make sure you pull out the paper support until it clicks.

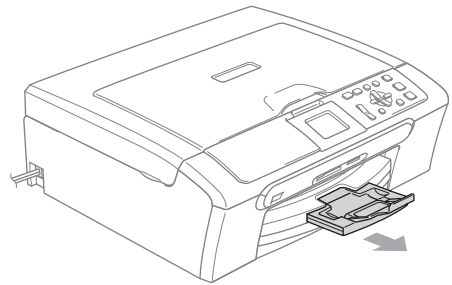

Routine maintenance

Replacing the ink cartridges

Your machine is equipped with an ink dot counter. The ink dot counter automatically monitors the level of ink in each of the 4 cartridges. When the machine detects an ink cartridge is running out of ink, the machine will tell you with a message on the LCD.

The LCD will tell you which ink cartridge is low or needs replacing. Be sure to follow the LCD prompts to replace the ink cartridges in the correct order.

Even though the machine tells you that an ink cartridge is empty, there will be a small amount of ink left in the ink cartridge. It is necessary to keep some ink in the ink cartridge to prevent air from drying out and damaging the print head assembly.

- 1 Open the ink cartridge cover. If one or more ink cartridges are empty, for example Black, the LCD shows Ink Empty Black.
- 2 Pull the lock release lever down and take out the ink cartridge for the color shown on the LCD.

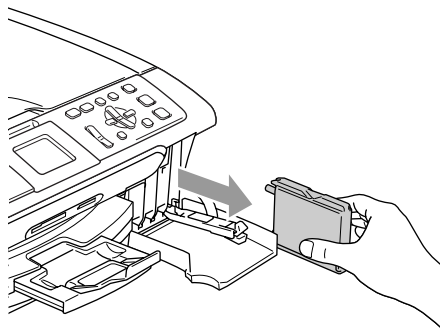
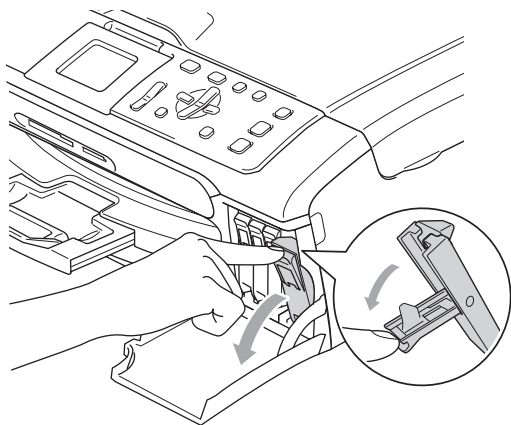

- 3 Open the new ink cartridge bag for the color shown on the LCD, and then take out the ink cartridge.
- 4 Remove the protective yellow cap (1).

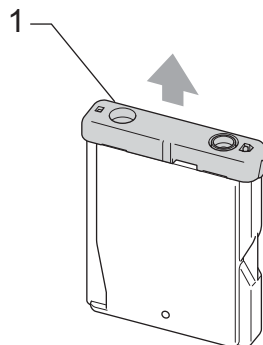

Improper Setup

DO NOT touch the area shown in the illustration below.

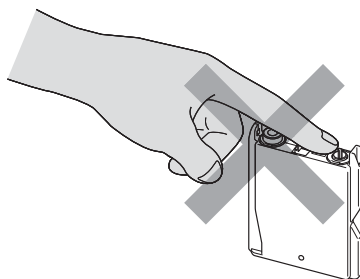

Note

If the protective yellow caps come off when you open the bag, the cartridge will not be damaged.

- 5 Each color has its own correct position. Insert the ink cartridge in the direction of the arrow on the label.

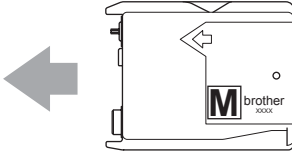

- 6 Lift the lock release lever and push it until it clicks, and then close the ink cartridge cover.

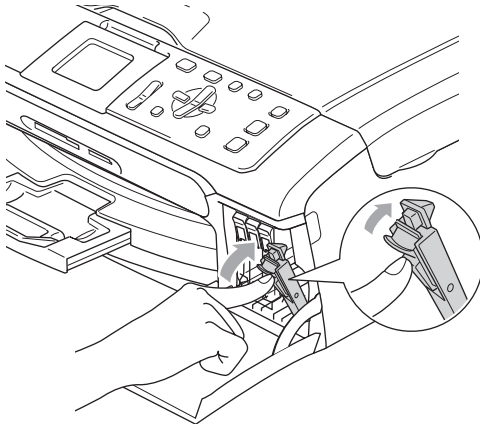

- 7 If you replaced an ink cartridge, the LCD may ask you to verify that it was a brand new one. (For example, Did You Change Black) For each new cartridge you installed, press + (Yes) to automatically reset the ink dot counter for that color. If the ink cartridge you installed is not a brand new one, be sure to press - (No). If you wait until the LCD shows Near Empty and Ink Empty, the machine will automatically reset the ink dot counter.



Note

If the LCD shows No Cartridge after you install the ink cartridges, check that the ink cartridges are installed properly.

! WARNING

If ink gets in your eyes, wash them out with water at once and call a doctor if you are concerned.

! CAUTION

DO NOT take out ink cartridges if you do not need to replace them. If you do so, it may reduce the ink quantity and the machine will not know the quantity of ink left in the cartridge.

DO NOT touch the cartridge insertion slots. If you do so, the ink may stain your skin.

If ink stains your skin or clothing, wash with soap or detergent at once.

If you mix the colors by installing an ink cartridge in the wrong position, clean the print head several times after correcting the cartridge installation.

Once you open an ink cartridge, install it in the machine and use it up within six months of installation. Use unopened ink cartridges by the expiration date written on the cartridge package.

DO NOT dismantle or tamper with the ink cartridge, this can cause the ink to leak out of the cartridge.

Brother strongly recommends that you do not refill the ink cartridges provided with your machine. We also strongly recommend that you continue to use only Genuine Brother Brand replacement ink cartridges. Use or attempted use of potentially incompatible ink and/or cartridges in the Brother machine may cause damage to the machine and/or may result in unsatisfactory print quality. Our warranty coverage does not apply to any problem that is caused by the use of unauthorized third party ink and/or cartridges. To protect your investment and obtain premium performance from the Brother machine, we strongly recommend the use of Genuine Brother Supplies.

Cleaning the outside of the machine

! CAUTION

Use neutral detergents. Cleaning with volatile liquids such as thinner or benzine will damage the outside surface of the machine.

DO NOT use cleaning materials that contain ammonia.

DO NOT use isopropyl alcohol to remove dirt from the control panel. It may crack the panel.

Clean the outside of the machine as follows:

- 1 Pull the paper tray (1) completely out of the machine.

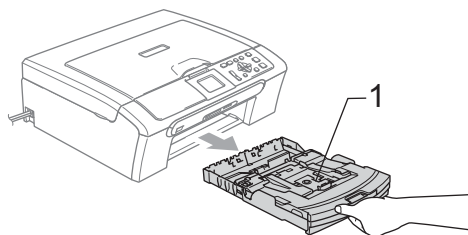

- 2 Wipe the outside of the machine with a soft cloth to remove dust.

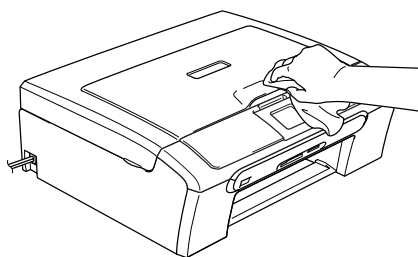

- 3 Lift the output paper tray cover and remove anything that is stuck inside the paper tray.
- 4 Wipe the inside and outside of the paper tray with a soft cloth to remove dust.

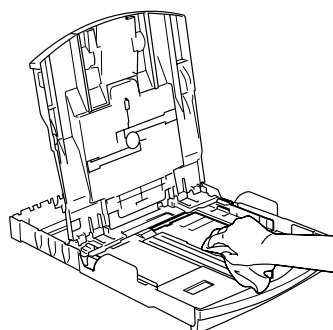

- 5 Close the output paper tray cover and put the paper tray firmly back in the machine.

Cleaning the scanner

- 1 Lift the document cover (1). Clean the scanner glass (2) and white plastic (3) with isopropyl alcohol on a soft lint-free cloth.

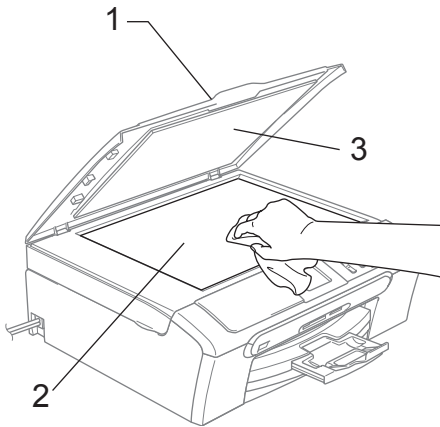

- 2 In the ADF unit, clean the white bar (1) and the glass strip (2) under it with isopropyl alcohol on a lint-free cloth.

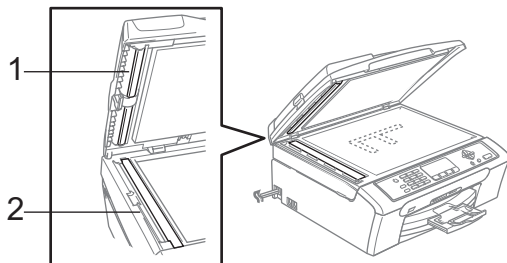

Cleaning the machine printer platen

WARNING

Unplug the machine from the AC power outlet before cleaning the printer platen (1).

If ink is scattered on or around the printer platen, wipe it off with a soft, dry, lint-free cloth.

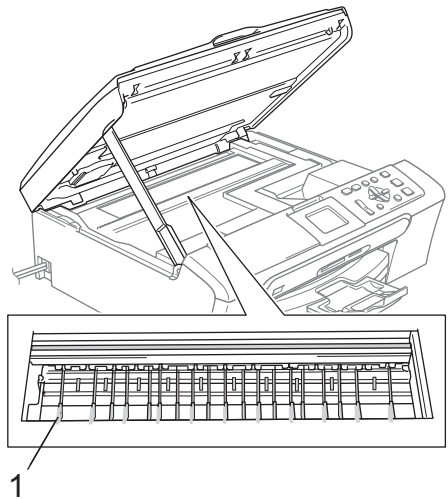

- 1 Clean the machine printer platen (1).

Cleaning the paper pick-up roller

- 1 Pull the paper tray completely out of the machine.
- 2 Unplug the machine from the AC power outlet and remove the Jam Clear Cover (1).

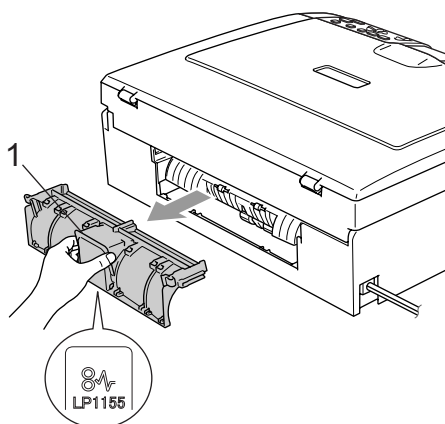

- 3 Clean the Paper Pick-up Roller (1) with isopropyl alcohol on a cotton swab.

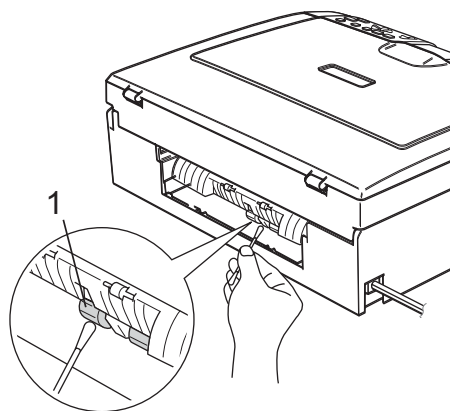

- 4 Put the Jam Clear Cover back on. Make sure the cover is set properly.
- 5 Re-connect the power cord.
- 6 Put the paper tray firmly back in the machine.

Cleaning the print head

To ensure the good print quality, the machine will regularly clean the print head. You can start the cleaning process manually if needed.

Clean the print head and ink cartridges if you get a horizontal line in the text or graphics on your printed pages. You can clean Black only (Yellow/Cyan/Magenta), or all four colors at once.

Cleaning the print head consumes ink. Cleaning too often uses ink unnecessarily.

! CAUTION

DO NOT touch the print head. Touching the print head may cause permanent damage and may void the print head's warranty.

- 1 Press **Ink**.
- 2 Press **▲** or **▼** to choose **Cleaning**. Press **OK**.
- 3 Press **▲** or **▼** to choose **Black**, **Color** or **All**. Press **OK**.
The machine cleans the print head. When cleaning is finished, the machine will go back to standby mode automatically.



Note

If you clean the print head at least five times and the print has not improved, call Brother Customer Service. (See *Brother numbers* on page i.)

Checking the print quality

If faded or streaked colors and text appear on your output, some of the nozzles may be clogged. You can check this by printing the Print Quality Check Sheet and looking at the nozzle check pattern.

- 1 Press **Ink**.
- 2 Press **▲** or **▼** to choose `Test Print`. Press **OK**.
- 3 Press **▲** or **▼** to choose `Print Quality`. Press **OK**.
- 4 Press **Color Start**. The machine begins printing the Print Quality Check Sheet.
- 5 Check the quality of the four color blocks on the sheet.
- 6 Do one of the following:
 - If all lines are clear and visible, press **+** to choose `Yes`, and go to step 10.
 - If you can see missing short lines as shown below, press **-** to choose `No`.

OK



Poor



- 7 The LCD asks you if the print quality is OK for black and three colors. Press **+** (`Yes`) or **-** (`No`).
- 8 The LCD asks you if you want to start cleaning. Press **+** (`Yes`). The machine starts cleaning the print head.
- 9 After cleaning is finished, press **Color Start**. The machine starts printing the Print Quality Check Sheet again and then return to step 5.

- 10 Press **Stop/Exit**. If you repeat this procedure at least five times and the print quality is still poor, replace the ink cartridge for the clogged colors. After replacing the ink cartridge, check the print quality. If the problem still exists, repeat the cleaning and test print procedures at least five times for the new ink cartridge. If ink is still missing, call Brother Customer Service. (See *Brother numbers* on page i.)

! CAUTION

DO NOT touch the print head. Touching the print head may cause permanent damage and may void the print head's warranty.

Note



When a print head nozzle is clogged the printed sample looks like this.



After the print head nozzle is cleaned, the horizontal lines are gone.

Checking the print alignment

You may need to adjust the print alignment after transporting the machine if your printed text becomes blurred or images become faded.

- 1 Press **Ink**.
- 2 Press **▲** or **▼** to choose `Test Print`. Press **OK**.
- 3 Press **▲** or **▼** to choose `Alignment`. Press **OK**.
- 4 Press **Black Start** or **Color Start**. The machine starts printing the Alignment Check Sheet.
- 5 Check the 600 dpi and 1200 dpi test prints to see if number 5 most closely matches number 0.
 - If the number 5 sample of both the 600 dpi and 1200 dpi are the best matches, press **+** (`Yes`) to finish Alignment Check, and go to step 8.
 - If another test print number is a better match for either 600 dpi or 1200 dpi, press **-** (`No`) to choose it.
- 6 For 600 dpi, press **◀** or **▶** to select the number of the test print that most closely matches the number 0 sample (1-8). Press **OK**.
- 7 For 1200 dpi, press **◀** or **▶** to select the number of the test print that most closely matches the number 0 sample (1-8). Press **OK**.
- 8 Press **Stop/Exit**.

Checking the ink volume

You can check the ink that is left in the cartridge.

- 1 Press **Ink**.
- 2 Press **▲** or **▼** to select `Ink Volume`. Press **OK**. The LCD shows the ink volume.
- 3 Press **Stop/Exit**.



Note

You can check the ink volume from your computer. (See *Printing for Windows*[®] or *Printing and Faxing for Macintosh*[®] in the Software User's Guide on the CD-ROM.)

Machine Information

Checking the serial number

You can see the machine's serial number on the LCD.

- 1 Press **Menu**.
- 2 Press **▲** or **▼** to select `Machine Info..`
Press **OK**.
- 3 Press **▲** or **▼** to select `Serial No..`
Press **OK**.
- 4 Press **Stop/Exit**.

Packing and shipping the machine

When you transport the machine, use the packing materials that came with your machine. If you do not pack the machine properly, you could void your warranty.

! CAUTION

It is important to allow the machine to 'park' the print head after a print job. Listen carefully to the machine before unplugging it to make sure that all mechanical noise has stopped. Not allowing the machine to finish this parking process may lead to print problems and possible damage to the print head.

- 1 Open the ink cartridge cover.
- 2 Pull the lock release levers down and take out all the ink cartridges. (See *Replacing the ink cartridges* on page 72.)
- 3 Install the yellow protective parts, lift each lock release lever and push it until it clicks, and then close the ink cartridge cover.

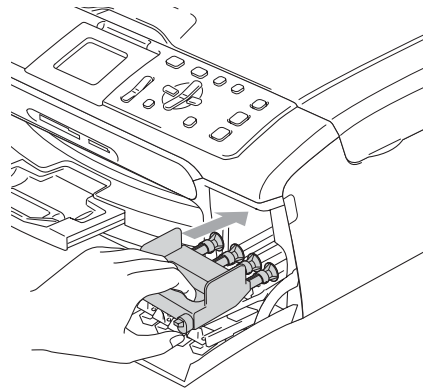

! CAUTION

If you are not able to find the yellow protective part, DO NOT remove the ink cartridges before shipping. It is essential that the machine be shipped with either the yellow protective part or the ink cartridges in position. Shipping without them will cause damage to your machine and may void your warranty.

- 4 Unplug the machine from the AC power outlet.
- 5 Using both hands, use the plastic tabs on both sides of the machine to lift the scanner cover until it locks securely into the open position. Then unplug the interface cable from the machine, if it is connected.
- 6 Lift the scanner cover to release the lock (1). Gently push the scanner cover support down (2) and close the scanner cover (3).

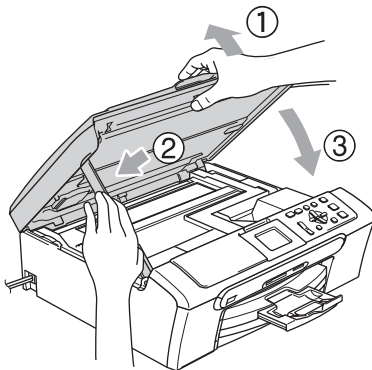

- 7 Wrap the machine in the bag and put it in the original carton with the original packing material.

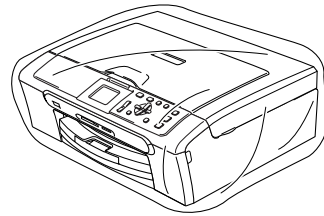

- 8 Pack the printed materials in the original carton as shown below. Do not pack the used ink cartridges in the carton.



Note

If you are returning your machine to Brother as part of the Exchange Service, pack *only* the machine. Keep all separate parts and printed materials to use with your 'Exchange' machine.

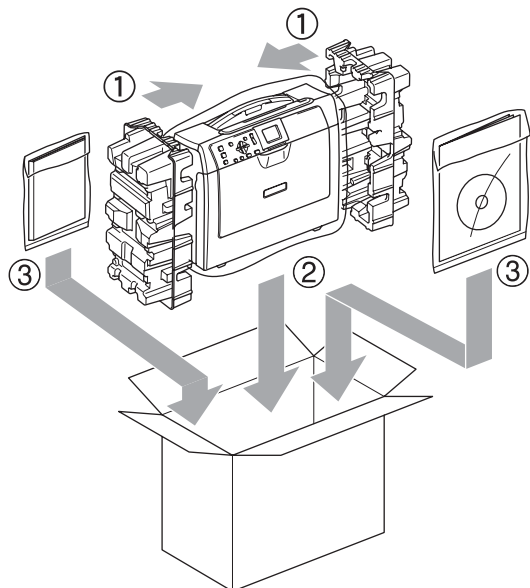

- 9 Close the carton and tape it shut.

On-screen programming







Your machine is designed to be easy to use with LCD on-screen programming using the menu keys. User-friendly programming helps you take full advantage of all the menu selections your machine has to offer.

Since your programming is done on the LCD, we have created step-by-step on-screen instructions to help you program your machine. All you need to do is follow the instructions as they guide you through the menu selections and programming options.

Menu table

You can program your machine without the User's Guide by using the Menu table that begins on page 82. These pages list the menu selections and options.

Menu keys

Menu 	Access the main menu.
 	Scroll through the current menu level.
	Go back to the previous menu level.
	Go to the next menu level.
OK 	<ul style="list-style-type: none"> ■ Go to the next menu level. ■ Accept an option.

Menu table

The menu table will help you understand the menu selections and options that are found in the machine's programs. The factory settings are shown in Bold with an asterisk.

Menu  Menu ()

Level 1	Level 2	Level 3	Options	Descriptions	Page	
General Setup	Paper Type	—	Plain Paper* Inkjet Paper Brother Photo Other Photo Transparency	Sets the type of paper in the paper tray.	23	
	Paper Size	—	Letter* Legal A4 A5 4"x6"	Sets the size of the paper in the paper tray.	23	
	LCD Settings	LCD Contrast		Light Med* Dark	Adjusts the contrast of the LCD.	24
		Backlight		Light* Med Dark	You can adjust the brightness of the LCD backlight.	24
		Dim Timer		Off 10 Secs 20 Secs 30 Secs*	You can set how long the LCD backlight stays on after the last key press.	25
		Off Timer		Off* 1 Min 2 Mins 3 Mins 5 Mins 10 Mins 30 Mins	You can set how long the LCD stays on for after the last key press.	25
	 The factory settings are shown in Bold with an asterisk.					

Level 1	Level 2	Level 3	Options	Descriptions	Page
LAN (DCP-540CN only)	TCP/IP	BOOT Method	Auto* Static RARP BOOTP DHCP	Chooses the BOOT method that best suits your needs.	See <i>Network User's Guide on the CD-ROM</i>
		IP Address	[000-255]. [000-255]. [000-255]. [000-255]	Enter the IP address.	
		Subnet Mask	[000-255]. [000-255]. [000-255]. [000-255]	Enter the Subnet mask.	
		Gateway	[000-255]. [000-255]. [000-255]. [000-255]	Enter the Gateway address.	
		Node Name	BRN_XXXXXX	Enter the Node name.	
		WINS Config	Auto* Static	Chooses the WINS configuration mode.	
		WINS Server	(Primary) 000.000.000.000 (Secondary) 000.000.000.000	Specifies the IP address of the primary or secondary server.	
		DNS Server	(Primary) 000.000.000.000 (Secondary) 000.000.000.000	Specifies the IP address of the primary or secondary server.	
		APIPA	On* Off	Automatically allocates the IP address from the link-local address range.	
		Setup Misc.	Ethernet	Auto* 100B-FD 100B-HD 10B-FD 10B-HD	
	Factory Reset	—	Yes No	Restores all network settings to the factory default.	
 The factory settings are shown in Bold with an asterisk.					



Level 1	Level 2	Level 3	Options	Descriptions	Page
Print Reports	Help List	—	—	Prints these lists and reports.	9
	User Settings	—	—		
	Network Config (DCP-540CN only)	—	—		
Machine Info.	Serial No.	—	—	Lets you check the serial number of your machine.	79
Initial Setup	Date/Time	—	—	Puts the date and time in your machine.	See <i>Quick Setup Guide</i>
	Local Language	—	English* French	Allows you to change the LCD language for your country.	
 The factory settings are shown in Bold with an asterisk.					

PhotoCapture ()



Level 1	Level 2	Level 3	Options	Descriptions	Page
View Photo(s)	—	—	See the print settings table below.	You can preview your photos on the LCD.	38
Print Index	—	—	6 Images/Line Fast 5 Images/Line Photo	You can print a thumbnail page.	39
Print All Photos	—	—	See the print settings table below.	You can print all photos in your media card.	39
Print Photos	—	—	See the print settings table below.	You can print an individual image.	40

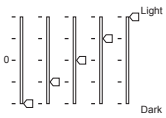
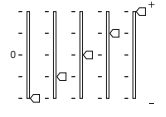
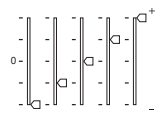
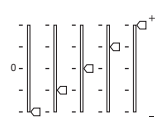
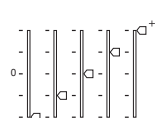

Print Settings

Option 1	Option 2	Option 3	Option 4	Descriptions	Page
Print Quality	Normal Photo*	—	—	Choose the print quality.	42
Paper Type	Plain Paper Inkjet Paper Brother Photo Other Photo*	—	—	Choose the paper type.	42
 The factory settings are shown in Bold with an asterisk.					

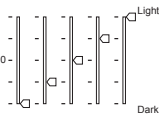
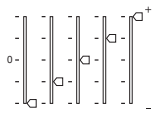
Option 1	Option 2	Option 3	Option 4	Descriptions	Page
Paper Size	Letter A4 4"x 6"* 5"x 7"	(When A4 or Letter is selected) 4"x 3" 5"x 3.5" 6"x 4" 7"x 5" 8"x 6" Max. Size*	—	Choose the paper and print size.	42
Brightness		—	—	Adjusts the brightness.	43
Contrast		—	—	Adjusts the contrast.	43
True2Life	On Off*	White Balance		Adjusts the hue of the white areas.	43
		Sharpness		Enhances the detail of the image.	
		Color Density		Adjusts the total amount of color in the image.	
Cropping	On* Off	—	—	Crops the image around the margin to fit the paper size or print size. Turn this feature off if you want to print whole images or prevent unwanted cropping.	44
Borderless	On* Off	—	—	Expands the printable area to fit the edges of the paper.	44
Set New Default	Yes No	—	—	You can save your print settings.	44
Factory Reset	Yes No	—	—	You can restore all the settings to factory settings.	44
	The factory settings are shown in Bold with an asterisk.				

Copy (Default display)

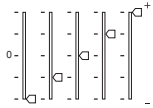
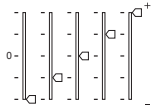
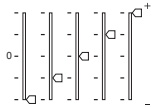
Level 1	Level 2	Level 3	Options	Descriptions	Page
Quality	—	—	Fast Normal* Best	Choose the Copy resolution for your type of document.	29
Enlarge/Reduce	—	—	50% 69% A4→A5 78% 83% 93% A4→LTR 97% LTR→A4 100%* 104% EXE→LTR 142% A5→A4 186% 4"x6"→LTR 198% 4"x6"→A4 200% Custom(25-400%)	You can choose the enlargement or reduction ratio for your type of document.	29
Paper Type	—	—	Plain Paper* Inkjet Paper Brother Photo Other Photo Transparency	Choose the paper type that matches the paper in the tray.	32
Paper Size	—	—	Letter* Legal A4 A5 4"x6"	Choose the paper size that matches the paper in the tray.	32
Brightness	—	—		Adjusts the brightness of copies.	31
Contrast	—	—		Adjusts the contrast of copies.	31
 The factory settings are shown in Bold with an asterisk.					

Level 1	Level 2	Level 3	Options	Descriptions	Page
Color Adjust	Red	—		Adjusts the amount of Red in copies.	32
	Green	—		Adjusts the amount of Green in copies.	
	Blue	—		Adjusts the amount of Blue in copies.	
Stack/Sort (DCP-540CN only)	—	—	Stack* Sort	You can choose to stack or sort multiple copies.	31
Page Layout	—	—	Off (1 in 1)* 2 in 1 (P) 2 in 1 (L) 4 in 1 (P) 4 in 1 (L) Poster (3 x 3)	You can make N in 1 or Poster copies.	30
Set New Default	—	—	Yes No	You can save your copy settings.	33
Factory Reset	—	—	Yes No	You can restore all the settings to factory settings.	33
 The factory settings are shown in Bold with an asterisk.					

Scan ()

Level 1	Option 1	Option 2	Option 3	Descriptions	Page
Scan to E-mail	—	—	—	You can scan a black & white or a color document into your E-mail application.	See <i>Software User's Guide on the CD-ROM</i>
Scan to Image	—	—	—	You can scan a color picture into your graphics application.	
Scan to OCR	—	—	—	You can have your text document converted to an editable text file.	
Scan to File	—	—	—	You can scan a black & white or a color document into your computer.	
Scan to Card	150 dpi Color* 300 dpi Color 600 dpi Color 200x100 dpi B/W 200 dpi B/W	PDF*/JPEG PDF*/JPEG PDF*/JPEG TIFF*/PDF TIFF*/PDF	(File Name) XXXXXXXX	You can choose the scan resolution and file format for your document.	45
 The factory settings are shown in Bold with an asterisk.					

General

Memory Capacity	32 MB
ADF (automatic document feeder)	Up to 10 pages Temperature: 68° F - 86° F (20° C - 30° C) Humidity: 50% - 70% Paper: [20 lb (80 g/m ²)] A4 or Letter size
Paper Tray	100 Sheets [20 lb (80 g/m ²)]
Printer Type	Ink Jet
Print Method	Black: Piezo with 94 × 1 nozzles Color: Piezo with 94 × 3 nozzles
LCD (liquid crystal display)	2.0 in. (50.8 mm) Color LCD
Power Source	AC 100 to 120V 50/60Hz
Power Consumption	(DCP-330C) Off Mode: Average 3 W Standby: Average 5 W Operating: Average 17 W (DCP-540CN) Off Mode: Average 4 W Standby: Average 6 W Operating: Average 29 W

Dimensions

(DCP-330C)

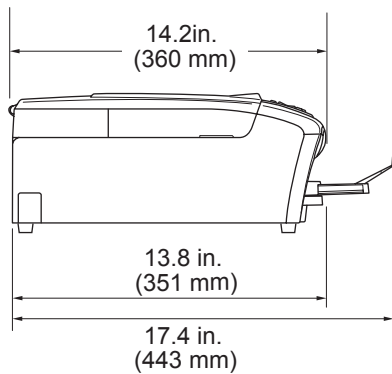
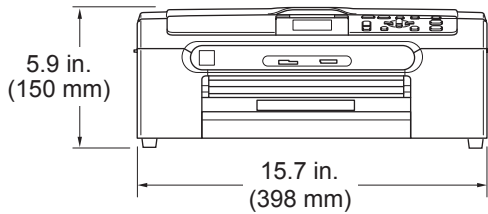

(DCP-540CN)

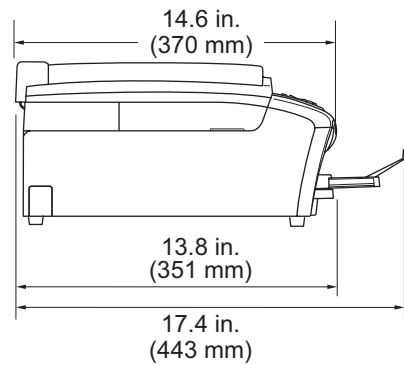
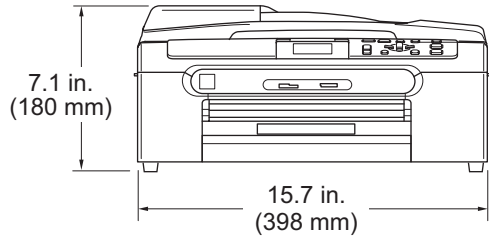

Weight

15.9 lb (7.2 kg) (DCP-330C)

17.6 lb (8.0 kg) (DCP-540CN)

Noise

Operating: 50 dB or less ¹

Temperature

Operating: 50° F to 95° F (10 to 35° C)

Best Print Quality: 68° F to 91° F (20 to 33° C)

Humidity

Operating: 20 to 80% (without condensation)

Best Print Quality: 20 to 80% (without condensation)

¹ This depends on printing conditions.

Print media

Paper Input

Paper Tray

- Paper type:

Plain paper, inkjet paper (coated paper), glossy paper², transparencies^{1 2} and envelopes

- Paper size:

Letter, Legal, Executive, A4, A5, A6, JIS B5, envelopes (commercial No.10, DL, C5, Monarch, JE4), Photo 2L 5"×7", Index card and Post card³.

For more details, see *Paper weight, thickness and capacity* on page 15.

- Maximum paper tray capacity: Approx. 100 sheets of 20 lb (80 g/m²) plain paper

Photo Bypass Tray (USA)

Photo Paper Tray (Canada)

- Paper type:

Plain paper, inkjet paper (coated paper) and glossy paper²

- Paper size:

Photo 4×6 in. and Photo L 3.5×5 in.

- Maximum paper tray capacity:

Approx. 20 sheets

Paper Output

Up to 50 sheets of 20 lb (80 g/m)² plain paper (face up print delivery to the output paper tray)²

¹ Use only transparencies recommended for inkjet printing.

² For glossy paper or transparencies, we recommend removing printed pages from the output paper tray immediately after they exit the machine to avoid smudging.

³ See *Paper type and size for each operation* on page 14.

Copy

Color/Monochrome	Yes/Yes
Document Size	ADF Width: 5.8 in. to 8.5 in. (148 mm to 215.9 mm) ADF Height: 5.8 in. to 14 in. (148 mm to 355.6 mm) Scanner Glass Width: Max. 8.5 in. (215.9 mm) Scanner Glass Height: Max. 11.7 in. (297 mm) Copy Width: Max. 8.26 in. (210 mm)
Copy Speed	Black: Up to 18 pages/minute (Letter paper) ¹ Color: Up to 16 pages/minute (Letter paper) ¹
Multiple Copies	Stacks/Sorts up to 99 pages
Enlarge/Reduce	25% to 400% (in increments of 1%)
Resolution	(Black & White) <ul style="list-style-type: none">■ Scans up to 600×1200 dpi■ Prints up to 1200×1200 dpi (Color) <ul style="list-style-type: none">■ Scans up to 600×1200 dpi■ Prints up to 600×1200 dpi

¹ Based on Brother standard pattern. (Fast mode/Stack Copy) Copy speeds vary with the complexity of the document.

PhotoCapture Center[®]

Available Media	CompactFlash [®] (Type I only) (Microdrive [™] is not compatible) (Compact I/O cards such as Compact LAN card and Compact Modem card are not supported.) Memory Stick [®] Memory Stick Pro [™] (Not available for music data with MagicGate [™]) MultiMediaCard [™] Secure Digital [™] xD-Picture Card [™] ¹
File Extension (Media Format) (Image Format)	DPOF, EXIF, DCF Photo Print: JPEG ² Scan to Card: JPEG, PDF (Color) TIFF, PDF (Black)
Color Enhancement	True2Life
Number of Files	Up to 999 files in the media card (including the folder inside media)
Folder	File must be in the 3rd folder level of the Media Card.
Borderless	Letter, A4, Photo 4"×6", Photo 5"×7" ³

¹ xD-Picture Card[™] Conventional Card from 16MB to 512MB
 xD-Picture Card[™] Type M from 256MB to 1GB
 xD-Picture Card[™] Type H from 256MB to 1GB

² Progressive JPEG format is not supported.

³ See *Paper type and size for each operation* on page 14.

PictBridge

Compatibility	Supports the Camera & Imaging Products Association PictBridge standard CIPA DC-001. Visit http://www.cipa.jp/pictbridge for more information.
Interface	PictBridge (USB) Port (cable not included).

Scanner

Color/Monochrome	Yes/Yes
TWAIN Compliant	Yes (Windows® 98/98SE/Me/2000 Professional/XP/Windows® XP Professional x64 Edition) Mac OS® X 10.2.4 or greater
WIA Compliant	Yes (Windows® XP ¹)
Color Depth	36 bit color Processing (Input) 24 bit color Processing (Output) (Actual Input: 30 bit color/Actual Output: 24 bit color)
Resolution	Up to 19200 × 19200 dpi (interpolated) ² Up to 600 × 2400 dpi (optical)
Scanning Speed	Color: up to 5.66 sec. Black: up to 3.59 sec. (Letter size at 100 × 100 dpi)
Document Size	ADF Width: 5.8 in. to 8.5 in. (148 mm to 215.9 mm) ADF Height: 5.8 in. to 14 in. (148 mm to 355.6 mm) Scanner Glass Width: Max. 8.5 in. (215.9 mm) Scanner Glass Height: Max. 11.7 in. (297 mm)
Scanning Width	8.26 in. (210 mm)
Gray Scale	256 levels

¹ Windows® XP in this User's Guide includes Windows® XP Home Edition, Windows® XP Professional, and Windows® XP Professional x64 Edition.

² Maximum 1200 × 1200 dpi scanning when using the WIA Driver for Windows® XP (resolution up to 19200 × 19200 dpi can be selected by using the Brother scanner utility)

Printer

Printer Driver	Windows® 98/98SE/Me/2000 Professional/XP/Windows® XP Professional x64 Edition driver supporting Brother Native Compression mode and bi-directional capability Brother Ink Driver For Mac OS® X 10.2.4 or greater
Resolution	Up to 1200 × 6000 dpi ¹ 1200 × 2400 dpi 1200 × 1200 dpi 600 × 600 dpi 600 × 300 dpi 600 × 150 dpi
Print Speed	Black: Up to 25 pages/minute ² Color: Up to 20 pages/minute ²
Printing Width	8.03 in. [8.5 in. (borderless) ³]
Disk-Based Fonts	35 TrueType
Borderless	Letter, A4, A6, Photo 4" × 6", Index Card, Photo L 3.5" × 5", Photo 2L 5" × 7", Post Card ⁴

¹ Output image quality varies based on many factors including, but not limited to input image resolution and quality and print media.

² Based on Brother standard pattern.
Letter size in draft mode.

³ When you set the Borderless feature to On.

⁴ See *Paper type and size for each operation* on page 14.

Interfaces

USB	A USB 2.0 interface cable that is no longer than 6 feet (2.0 m). ^{1 2}
LAN cable ³ (DCP-540CN only)	Ethernet UTP cable category 5 or greater.

¹ Your machine has a USB 2.0 Full-speed interface. This interface is compatible with USB 2.0 Hi-Speed; however, the maximum data transfer rate will be 12 Mbits/s. The machine can also be connected to a computer that has a USB 1.1 interface.

² Third party USB ports are not supported for Macintosh®.

³ See the *Network User's Guide* on the CD-ROM for detailed network specification.

Computer requirements

Minimum System Requirements and Supported PC Software Functions								
Computer Platform & Operating System Version		Supported PC Software Functions	Interface	Minimum Processor Speed	Minimum RAM	Recommended RAM	Available Hard Disk Space	
							for Drivers	for Applications
Windows® Operating Systems ¹	98, 98SE	Printing, Scanning, Removable Disk ³	USB Ethernet (DCP-540CN only)	Intel® Pentium® II or equivalent	32MB	128MB	120MB	130MB
	Me				64MB	256MB		
	2000 Professional				128MB	256MB	170MB	220MB
	XP Home XP Professional XP Professional x64 Edition			AMD Opteron™ AMD Athlon™ 64 Intel® Xeon™ with Intel® EM64T Intel® Pentium® 4 with Intel® EM64T	256MB	512MB	170MB	220MB
Apple® Macintosh® Operating Systems	OS X 10.2.4 or greater	Printing, Scanning, Removable Disk ³	USB ² Ethernet (DCP-540CN only)	PowerPC G3/G4/G5, Intel Core Solo/Duo 350 MHz	128MB	256MB	80MB	200MB
¹ Microsoft® Internet Explorer 5 or greater. ² Third party USB ports are not supported. ³ Removable disk is a function of PhotoCapture Center®.			For the latest driver updates, access the Brother Solutions Center at http://solutions.brother.com/					

Consumable items

Ink

The machine uses individual Black, Yellow, Cyan and Magenta ink cartridges that are separate from the print head assembly.

Service Life of Ink Cartridge

The first time you install the ink cartridges the machine will use extra ink to fill the ink delivery tubes. This is a one-time process that enables high quality printing. Afterward, replacement ink cartridges will print the specified number of pages.

Replacement Ink Cartridges

Standard Black - Approximately 500 pages at 5% coverage

Yellow, Cyan and Magenta - Approximately 400 pages at 5% coverage

The above figures are based upon the following assumptions:

- Continuous printing at a resolution of 600 × 600 dpi in normal mode after installing new ink cartridge;
- The printing frequency;
- The number of pages printed;
- Periodic, automatic, print head assembly cleaning (Your machine will clean the print head assembly periodically. This process will use a small amount of ink); and,
- Ink remaining in cartridge identified as 'empty' (It is necessary to leave a small amount of ink in the ink cartridge to prevent air from drying out and damaging the print head assembly).

Replacement Consumables

<Black> LC51BK, <Yellow> LC51Y, <Cyan> LC51C,
<Magenta> LC51M

Network (LAN) (DCP-540CN only)

LAN	You can connect your machine to a network for Network Printing and Network Scanning (Windows® only). Also included is Brother BRAdmin Professional Network Management software for Windows® and BRAdmin Light for Mac OS® X 10.2.4 or greater.
Support for	Windows® 98/98SE/Me/2000/XP/XP Professional x64 Edition Mac OS® X 10.2.4 or greater Ethernet 10/100 BASE-TX Auto Negotiation (Wired LAN)
Protocols	TCP/IP ARP, RARP, BOOTP, DHCP, APIPA (Auto IP), NetBIOS Name Resolution, WINS DNS Resolver, LPR/LPD, Custom Raw Port/Port9100, FTP Server, mDNS, TELNET, SNMP

E

Glossary

This is a comprehensive list of features and terms that appear in Brother manuals. Availability of these features depends on the model you purchased.

ADF (automatic document feeder)

The document can be placed in the ADF and scanned one page at a time automatically.

Brightness

Changing the Brightness makes the whole image lighter or darker.

Contrast

Setting to compensate for dark or light documents, by making copies of dark documents lighter and light documents darker.

Help list

A printout of the complete Menu table that you can use to program your machine when you do not have the User's Guide with you.

LCD (liquid crystal display)

The display screen on the machine that shows interactive messages during On-Screen Programming.

Menu mode

Programming mode for changing your machine's settings.

OCR (optical character recognition)

The bundled ScanSoft® PaperPort® SE with OCR or Presto!® PageManager® software application converts an image of text to text you can edit.

PhotoCapture Center®

Allows you to print digital photos from your digital camera at high resolution for photo quality printing.

PictBridge

Allows you to print photos directly from your digital camera at high resolution for photo quality printing.

Scanning

The process of sending an electronic image of a paper document into your computer.

Scan to Card

You can scan a black and white or color document into a Media Card. Black and white images can be in TIFF or PDF file format and color images can be in PDF or JPEG file format.

Temporary settings

You can choose certain options for each copy without changing the default settings.

True2Life®

Adjusts the color in the image for better print quality by improving sharpness, white balance and color density.

User Settings

A printed report that shows the current settings of the machine.

F

Index

A

- Accessories and supplies ii
- ADF (automatic document feeder) 10
- Apple® Macintosh®
 - See Software User's Guide on the CD-ROM.

B

- Brother
 - accessories and supplies ii
 - Brother numbers i
 - Customer Service i
 - FAQs (frequently asked questions) i
 - fax back system ii
 - product support i
 - Solutions Center i
 - Warranties iii, iv, vi

C

- Cleaning
 - paper pick-up roller 76
 - print head 76
 - printer platen 75
 - scanner 75
- Consumable items 97
- Control panel overview 6
- ControlCenter
 - See Software User's Guide on the CD-ROM.
- Copy
 - brightness 31
 - contrast 31
 - enlarge/reduce 29
 - multiple 28
 - page layout (N in 1, poster) 30
 - paper size 32
 - paper type 32
 - quality 29
 - Return to default 33
 - set new default 33
 - single 28
 - sort (ADF only) 31
 - using ADF 10, 28
 - using scanner glass 11

D

- Document
 - loading 10, 11
 - scannable area 11

E

- Envelopes 14, 18, 19, 20
- Error messages on LCD 67
 - Ink Empty 67
 - Near Empty 67
 - No Paper Fed 68
 - Out of Memory 68
 - Unable to Change 68
 - Unable to Clean 68
 - Unable to Init. 68
 - Unable to Print 68
 - Unable to Scan 68

G

- Gray scale 94

H

- HELP
 - LCD messages 81
 - using Menu keys 81
 - Menu Table 81, 82

I

- Ink cartridges
 - checking ink volume 78
 - ink dot Counter 72
 - replacing 72
- Ink key 7

J

- Jams
 - document 69
 - paper 70

L

LCD (liquid crystal display)	81
Brightness	24
Contrast	24
Dim Timer	25
Help List	9
Off Timer	25

M

Macintosh®	
See Software User's Guide on the CD-ROM.	
Maintenance, routine	72
Menu Table	81
Mode, entering	
PhotoCapture	7
Scan	7

N

Network	
Printing	
See Network User's Guide on the CD-ROM.	
Scanning	
See Software User's Guide on the CD-ROM.	
Number of Copies key	6

O

On/Off key	7
------------------	---

P

Paper	12, 91
capacity	15
loading	16, 18, 20
printable area	22
size	14, 23
size of document	10
type	14, 23
PaperPort® SE with OCR	
See Software User's Guide and PaperPort® SE with OCR User's Guide on the CD-ROM.	
Photo Bypass Tray (USA)	20

Photo Paper Tray (Canada)	20
PhotoCapture Center®	
Borderless	44
CompactFlash®	36
Cropping	44
DPOF printing	40
from PC	
See Software User's Guide on the CD-ROM.	
Memory Stick Pro™	36
Memory Stick®	36
MultiMediaCard™	36
Preview photos	38
Print settings	
Brightness	43
Contrast	43
Paper type & size	42
Quality	41, 42
Return to factory setting	44
Set new default	44
Printing	
all photos	39
index	39
photos	40
Scan to Card	45
SecureDigital™	36
specifications	93
xD-Picture Card™	36
PictBridge	47
DPOF Printing	48
Presto!® PageManager®	
See Help in Presto!® PageManager® to access the User's Guide.	
Print	
area	22
difficulties	63
drivers	95
improving quality	77
on small paper	21
paper jams	70
reports	9
resolution	95
specifications	95
Programming your machine	81

R

Reducing copies	29
Reports	
Help List	9
how to print	9
User Settings	9
Resolution	
copy	92
print	95
scan	94

S

Safety Instructions	58
Scannable area	11
Scanning	
See Software User's Guide on the CD-ROM.	
Serial Number	
how to find.....	See inside front cover
Shipping the machine	79

T

Transparencies	12, 15
Troubleshooting	63
checking ink volume	78
document jam	69
error messages on LCD	67
if you are having difficulty	
copying	65
Network	66
PhotoCapture Center®	65
printing	63
scanning	65
software	65
paper jam	70
print quality	77

W

Warranties	iii
Canada	vi
Notice-Disclaimer	iii
USA	iv
Windows®	
See Software User's Guide on the CD-ROM.	
World Wide Web	i

EQUIPMENT ATTACHMENT LIMITATIONS (Canada only)

NOTICE

This product meets the applicable Industry Canada technical specifications.

Brother International Corporation
100 Somerset Corporate Boulevard
P.O. Box 6911
Bridgewater, NJ 08807-0911 USA

Brother International Corporation (Canada) Ltd.
1 rue Hôtel de Ville,
Dollard-des-Ormeaux, QC, Canada H9B 3H6

brother[®]

Visit us on the World Wide Web
<http://www.brother.com>

These machines are made for use in the USA and Canada only. We cannot recommend using them overseas because the power requirements of your machine may not be compatible with the power available in foreign countries. **Using USA or Canada models overseas is at your own risk and may void your warranty.**



LP3289001
US/CAN
Printed in China

Free Manuals Download Website

<http://myh66.com>

<http://usermanuals.us>

<http://www.somanuals.com>

<http://www.4manuals.cc>

<http://www.manual-lib.com>

<http://www.404manual.com>

<http://www.luxmanual.com>

<http://aubethermostatmanual.com>

Golf course search by state

<http://golfingnear.com>

Email search by domain

<http://emailbydomain.com>

Auto manuals search

<http://auto.somanuals.com>

TV manuals search

<http://tv.somanuals.com>