

## **TRASH COMPACTOR SERVICE MANUAL**

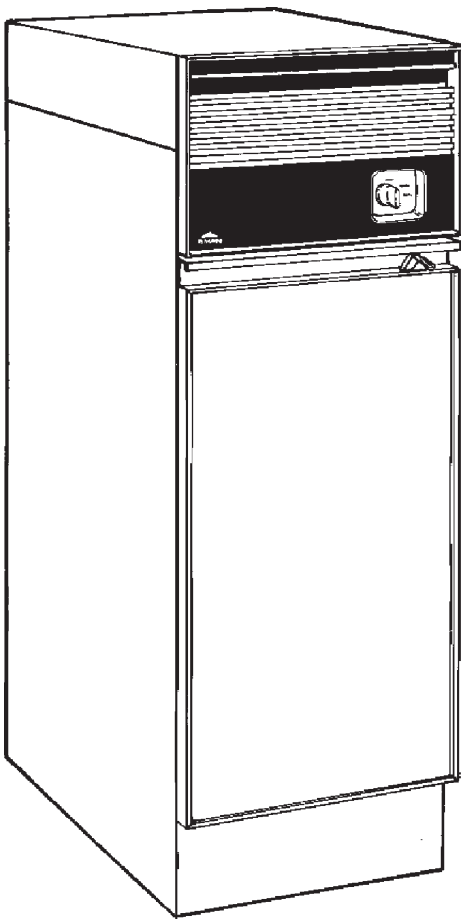

**MODELS  
1050L-C & 1051L-C**

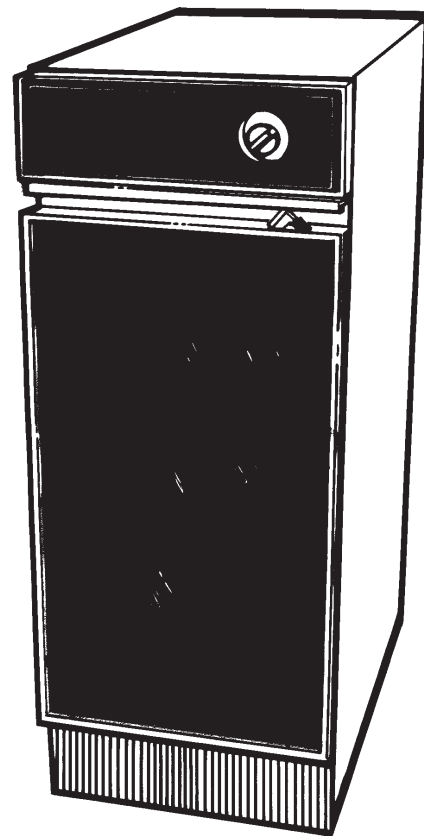

**MODELS  
1055-K & 1059-C**

## CONTENTS

|   |           |
|---|-----------|
| Safety Precautions .....                  | 2         |
| Model and Serial No. Identification ..... | 2         |
| Transporting Compactor .....              | 2         |
| Manually Raising and Lowering Ram .....   | 2         |
| Troubleshooting Guide .....               | 3 & 4     |
| Component Replacement .....               | 5, 6 & 7  |
| Greasing Compactor Mechanism .....        | 7         |
| Wiring Diagrams .....                     | 8         |
| Parts Lists .....                         | 9 thru 12 |

## SAFETY PRECAUTIONS

### ALWAYS UNPLUG COMPACTOR FROM WALL OUTLET BEFORE SERVICING.

The service information is intended for use by a service technician who is familiar with proper and safe procedures to be followed when repairing electrical appliances and who is equipped with proper tools and testing devices. Repairs attempted or made improperly can result in personal injury or property damage. Hazards may develop from improper assembly or adjustments. While making repairs, persons not having the proper background may subject themselves to the risk of injury or electrical shock which can be serious or even fatal.

### IMPORTANT - NOTE TO THE CONSUMER

If you perform service on your own Broan products, you must assume responsibility for personal injury or property damage which may result.

## MODEL AND SERIAL NO. IDENTIFICATION

The specification label with model and serial numbers is located on the inside of the cabinet. It is visible after opening the drawer.

## TRANSPORTING COMPACTOR

When transporting compactor, the ram should be electrically or manually extended down into the drawer, preferably against a load of stacked newspapers or other suitable material. If this is not done, damage to the trunnion nut may occur.

Never transport compactor on its back or front. Damage to the gearbox may occur. If it cannot be transported upright, it is preferable to place it on its side.

## MANUAL RAISING AND LOWERING OF RAM

Unplug compactor cord from wall socket. Remove back panel. The ram may be raised or lowered manually by using a 15/16" socket to turn the drive screw nut. Clockwise will lower ram, counterclockwise will raise it.

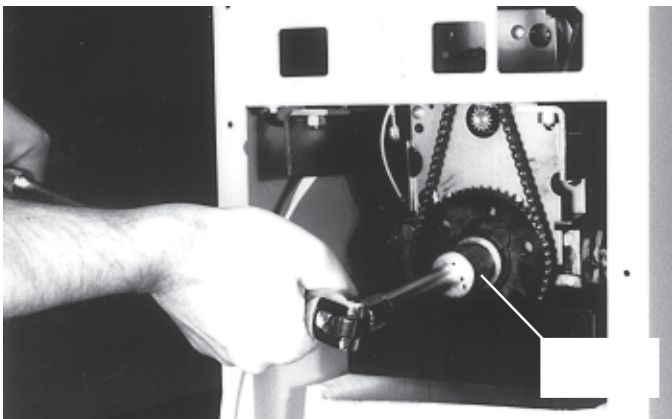

## BAG INSTALLATION

DO NOT use plastic bags other than those which have been designed for use in this compactor. Unauthorized bags may become caught in the mechanism.

With the drawer extended to the second stop, release the container latch and swing open door. Slide bag into drawer from front to back. Fold bag over top rim of drawer on all sides.

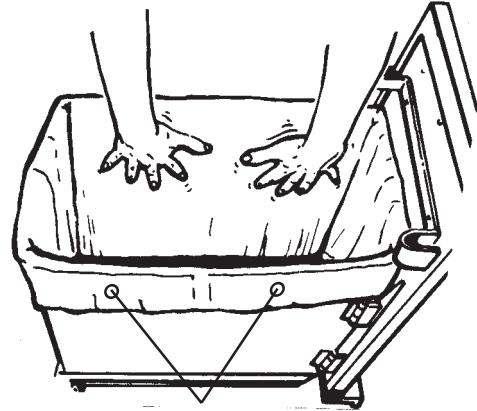

Press bag into all corners of the drawer. Smooth and shape the bag carefully - this will prevent the bag from being torn by the ram during compaction.

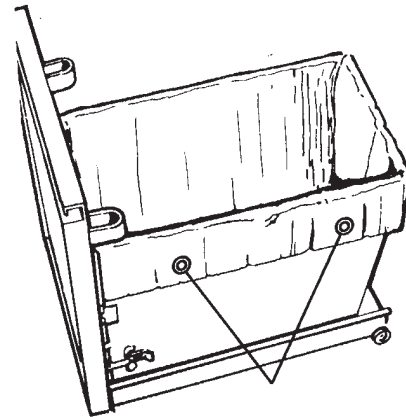

Using buttons on side of drawer, button bag in place by using prepunched holes in side of bag. NOTE: If you have difficulty installing bag, move drawer completely from unit by lifting front of drawer slightly and pulling forward (place on rug or other surface to protect floor). This will clear back of container from housing for easier bag installation.

Swing door shut and latch it. Bag is locked between door flange and drawer. When door is closed and latched properly, door guide "V" will be snug in "V" groove in drawer flange. Bag should be captured in "V" guide. Failure to align "V" properly or to latch drawer to door will cause the compactor to function improperly.

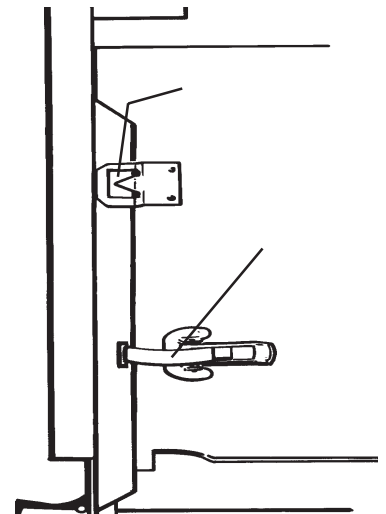

# TROUBLESHOOTING GUIDE

| <u>Condition</u> | <u>Possible Cause</u> | <u>Correction</u> | <u>Special Notes</u> |
|------------------|-----------------------|-------------------|----------------------|
|------------------|-----------------------|-------------------|----------------------|

# TROUBLESHOOTING GUIDE

| <u>Condition</u> | <u>Possible Cause</u> | <u>Correction</u> | <u>Special Notes</u> |
|------------------|-----------------------|-------------------|----------------------|
|------------------|-----------------------|-------------------|----------------------|

## CABINET REPLACEMENT - POWER PACK REMOVAL

A box or similar stand approximately 11" high x 15" long x 7" wide is recommended for power pack removal. The box must be able to support 60 lbs. or more since you will be placing the full weight of the power pack on it.

1. Unplug compactor from socket.
2. Remove drawer assembly from cabinet.
3. Remove Air Scentry tray and control panel.
4. Remove key switch control bracket assembly. Remove back panel.
5. Place box in cabinet and lower ram manually by turning 15/16" nut on sprocket clockwise. Box should support weight of power pack.
6. Remove the four 5/16" nuts supporting the power pack in the cabinet.
7. Disconnect ground wire attached to cabinet.
8. Turn 15/16" nut counterclockwise causing power pack to lower down out of cabinet. Pull power pack out through front of rear of compactor.

If you are replacing the cabinet, remove remaining parts from old cabinet and install on new. See appropriate sections of service manual.

Reverse procedure to install power pack. Be sure the weld strip, grommets, and spacers are in place. The lock nuts should be torqued to 5 ft./lbs. (60 inch/lbs.). Do not overtorque.

Be careful not to pinch or nick any wires when installing power pack in cabinet.

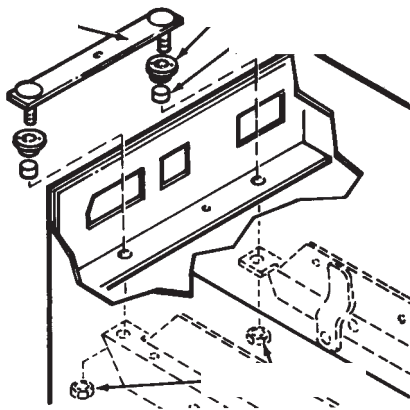

## CONTROL PANEL

On units with a bag storage compartment, removal of the storage compartment will make replacement of the control panel easier.

1. Remove drawer assembly.
2. Remove the four screws securing the air scentry tray and the bottom of control panel to the cabinet.
3. Pull bottom of control panel out slightly and then up.

When installing the control panel, make sure lip on inside of control panel snaps behind the bend in the control panel bracket.

## STORAGE COMPARTMENT

(Models 1050L & 1051L only)

Remove two screws on rear of compactor and the two 5/16" hex head screws inside the storage compartment. Slide compartment back and lift off.

## DRAWER ASSEMBLY

1. Pull out drawer until it stops.
2. Lift drawer slightly, then pull out drawer to second stop.
3. Lift drawer up and out of compactor.

## DOOR LINER - LATCH ASSEMBLY

Remove the door from the drawer by unlatching the door and removing the hinge pins. The door liner can be removed from the door by removing the toe space cover and all screws holding the door liner to the door. Slide the door liner to side of door and lift off.

## DRAWER AND BASE ROLLERS

All four of the rollers are secured with a 1/2" hex nut and slotted for screwdriver. Roller nuts are installed using Loctite<sup>®</sup> and torqued to 20 foot pounds. Rollers are pregreased and should require no lubricant.

## BOTTOM ASSEMBLY

1. Unscrew level legs from base. Remove tee nuts that legs screw into.
2. Remove screws securing bottom assembly to the cabinet.
3. Lower the bottom down into the cabinet, back end first, then bring it up and out through the notches in the bottom flange of the cabinet.

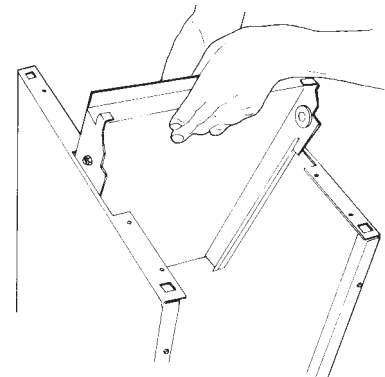

## SWITCH LOCATIONS

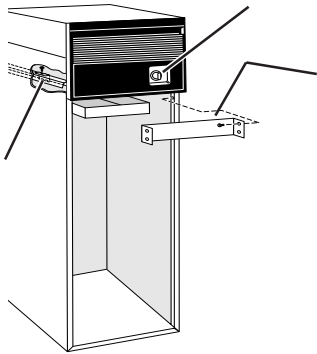

### KEY SWITCH

1. Remove control panel.
2. Remove two hex head screws supporting control panel bracket with 5/16" socket.
3. Pull bracket out and remove switch.

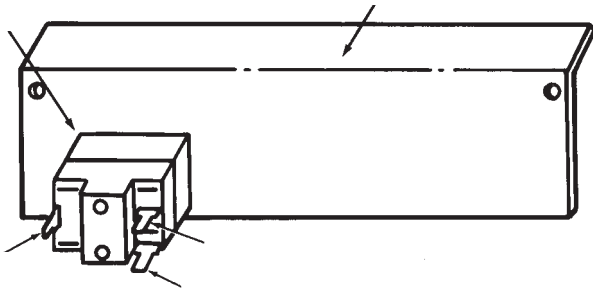

### UPPER LIMIT SWITCH

1. Remove drawer assembly.
2. Lower ram to gain access to switch.
3. Remove air scentry tray.
4. Remove hex head screw with 5/16" socket, pull switch down and disconnect wires.

| Check Continuity | Switch not Activated | Switch Activated |
|------------------|----------------------|------------------|
| 3 to 1           | closed               | open             |
| 2 to 1           | open                 | closed           |
| 6 to 1           | open                 | open             |
| 3 to 4           | open                 | open             |
| 6 to 4           | closed               | open             |
| 5 to 7           | open                 | closed           |

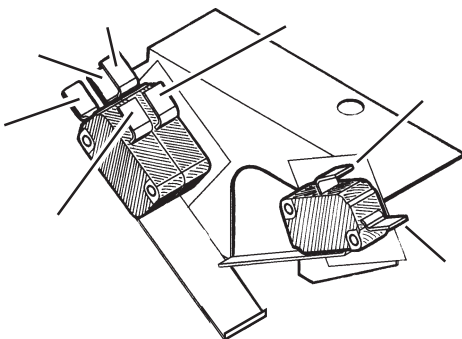

### INTERLOCK SWITCH

The interlock switch is a single-pole, single-throw momentary type. It is located on the right side behind the air scentry panel. Its contacts are normally open. The contacts close when the door is closed. It is activated by the actuator located on the back of

the door. Another switch located against the interlock switch is to provide the "No-Jam" circuitry function. This switch is normally open and bypasses the interlock to provide "No-Jam" capability. It can be replaced in the same manner as the interlock switch.

### TO REPLACE INTERLOCK SWITCH

1. Remove air scentry panel assembly.
2. Disconnect leads one by one and attach to new switch.

### TRUNNION NUT

1. Remove back panel, drawer assembly and air scentry panel.
2. Lower ram manually to approx. 10-1/2" from the bottom assembly onto box or stand described in "CABINET REPLACEMENT/POWER PACK REMOVAL" section.
3. Remove screws from nut retainer.
4. Raise ram assembly slightly by hand and remove nut.

NOTE: Count the number of revolutions to spin off nut. TRUNNION must be reinstalled to same position.

5. Reinstall trunnion nut and retainer.

### CONTINUAL STRIPPING OF TRUNNION NUT: POSSIBLE CAUSES:

1. Incorrect assembly of trunnion assembly.
2. Transporting compactor incorrectly.
3. Burr on main drive screw; sharp edge on lead-in thread.
4. Upper limit switch adjustment.

### REMOVING PLASTIC BAGS FROM TRUNNION NUT

Only the trash compactor bags specifically designed and sold by Broan for use in the compactor should be used. Regular plastic garbage bags used in place of the Broan bags may be drawn into the mechanism. Removal of those bags is not covered by the warranty.

To remove bag from trunnion nut:

1. Remove back of compactor.
2. If possible to slide drawer slightly, remove the door by sliding out the two hinge pins and then prying the door over the lip on the drawer.
3. Liberally spray drive screw and trunnion nut with WD-40<sup>R</sup> or similar.
4. Use 15/16" socket, and extension, and a 16" ratchet (for leverage) and manually turn the drive screw clockwise. (See section on manually raising and lowering ram.) By turning the drive screw clockwise, you will help back the bag out of the trunnion nut.
5. After removing bag, clean drive screw and regrease it with wheel bearing grease.

### DRIVE SCREW

1. Lower ram manually approximately halfway.
2. Remove sprocket.
3. Remove 1/4" drive pin. Slide off washers.
4. Lift ram, causing drive screw to slide out of the motor trunnion bearing. Support motor/gearbox assembly since it is now free to pivot. Unscrew drive screw from front trunnion assembly.



## TRUNNION BEARING

1. Remove sprocket and drive pin.
2. Pull out trunnion bearing.

Grease trunnion bearing inside and out with wheel bearing grease prior to reinstalling.

## MOTOR TRUNNION

1. Remove motor, gearbox, sprocket, and screw guard.
2. Use 13/16" wrench to remove bolts securing links to motor trunnion.

When reinstalling, bolts torque to 45 foot pounds.

## SPROCKET

1. Line up one of the 3/8" holes in the sprocket with the 3/8" hole in bottom center of gearbox. Insert 3/8" steel pin or bolt through sprocket hole into front and rear gearbox holes.\*
2. Loosen and remove 15/16" nut on the drive screw. When reinstalling torque to 65 foot pounds and apply Loctite® to threads.

\*If the sprocket is too damaged to be able to use on of the holes to secure it, chip away the remaining sprocket, remove the drive pin and then insert a screwdriver through the hole to provide a means of keeping the drive screw from turning.

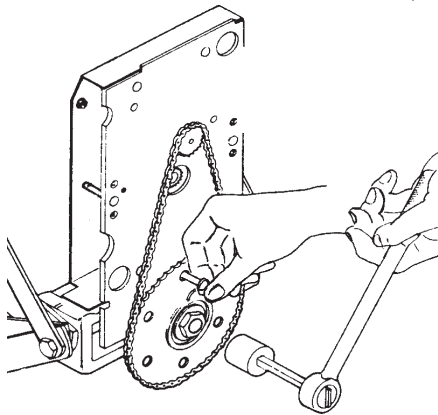

## CHAIN

1. Turn sprocket until two holes in sprocket line up with socket head cap screws.
2. Remove socket head cap screws and tip gearbox/motor assembly to remove chain. NOTE: The screws thread into 2 nuts which rest in slots in the motor trunnion. Be careful not to lose the 2 nuts when the screws are removed.

When reinstalling socket head cap screws, be sure Loctite® is applied to the nuts.

**Chain Derailment:** Loose chains. Sometimes a chain will derail because trash which flew up above the ram during compacting fouled the chain. Newspaper or a paper bag should be placed on top of glass bottles before compacting to prevent this.

If continual derailment of the chain is a problem, inspect both sprockets for worn or missing teeth. Inspect gearbox mounting and mounting plate. If the mounting screws are loose, gearbox movement may be the cause. If the gearbox mounting plate is bent where it meets the motor trunnion, either straighten or replace the gearbox.

Some chain looseness is normal and may increase as the compactor is used. Seldom does the chain "stretch" to the point where it is too loose.

## GEARBOX

1. Lower ram manually until there is approximately 11" to 12" between the ram and the bottom assembly.
2. Remove the four 3/8" nuts securing motor to gearbox, slide motor out and rest it on the front trunnion assembly.
3. Turn sprocket until two holes in sprocket line up with the two socket head cap screws that hold the gearbox to the motor trunnion.
4. Remove the two socket head cap screws with a 5/32" hex key. NOTE: The screws thread into 2 nuts which rest in slots in the motor trunnion. Be careful not to lose the 2 nuts when the screws are removed.
5. Tilt gearbox forward and remove chain. Lift gearbox out.

When installing gearbox, Loctite® should be applied to the socket head cap screw nuts.

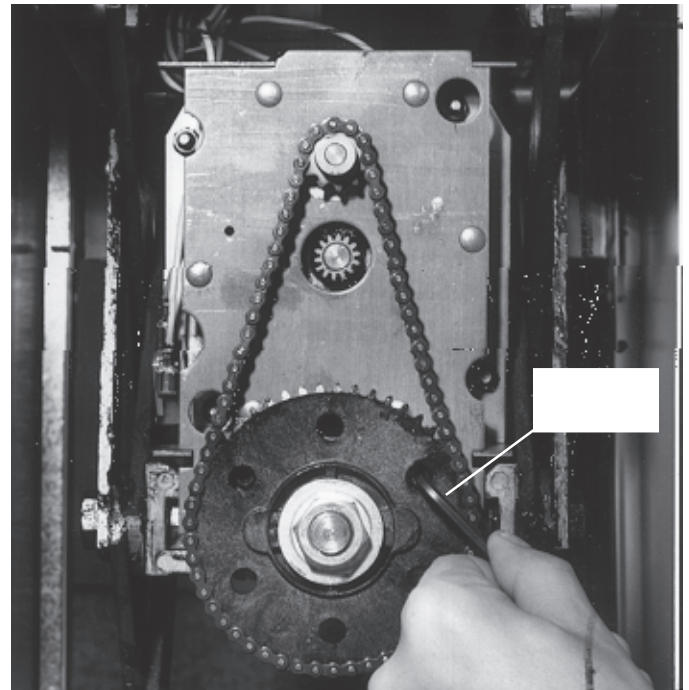

## GREASING COMPACTOR MECHANISM

1. Unplug compactor from wall outlet.
2. Remove drawer assembly from compactor.
3. Remove back of compactor and lower mechanism manually by turning 5/8" nut on sprocket clockwise.
4. Line up one of the holes in the black sprocket with the hole in the gearbox. Insert a 3/8" bolt or pin to keep sprocket from turning and remove the 15/16" nut.
5. Slide off sprocket and washer.
6. Drive out the drive pin, slide off thin washer and pull out trunnion bearing.
7. Grease trunnion bearing everywhere, inside and out, with regular wheel bearing grease.
8. Reassemble unit in reverse procedure. When reinstalling 15/16" nut, be sure to apply a drop of Loctite® or equivalent to the threads of the 15/16" nut.

Apply grease to length of drive screw and a dab to the scissor links at the pivot points.

# MOTOR

Before motor is removed, it should be tested to be sure it is inoperative. Check the continuity of the motor.

## CHECK CONTINUITY

|                      |   |
|----------------------|---|
| Black to Orange      | If open, replace motor  |
| Red to Orange        | If open, replace motor  |
| Gray to Orange       | If open, replace motor  |
| Green to Motor Frame | If open, inspect wire to be sure it is properly attached to motor frame |

1. Lower ram manually until there is approximately 7" between the bottom assembly and the ram.
2. Disconnect mox connector from motor to wire harness.
3. Using a 3/8" nut driver or socket, remove the four nuts holding the motor to the gearbox. Remove air scentry tray and pull motor out through front of compactor.
4. Install motor in reverse procedure.

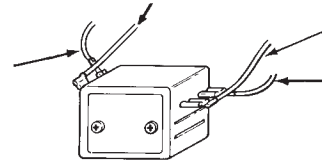
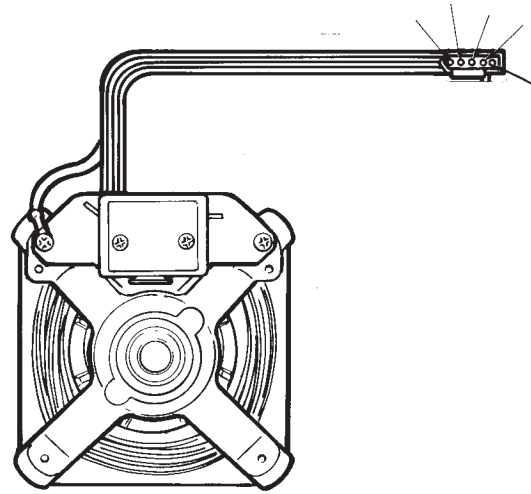

## WIRING SCHEMATIC

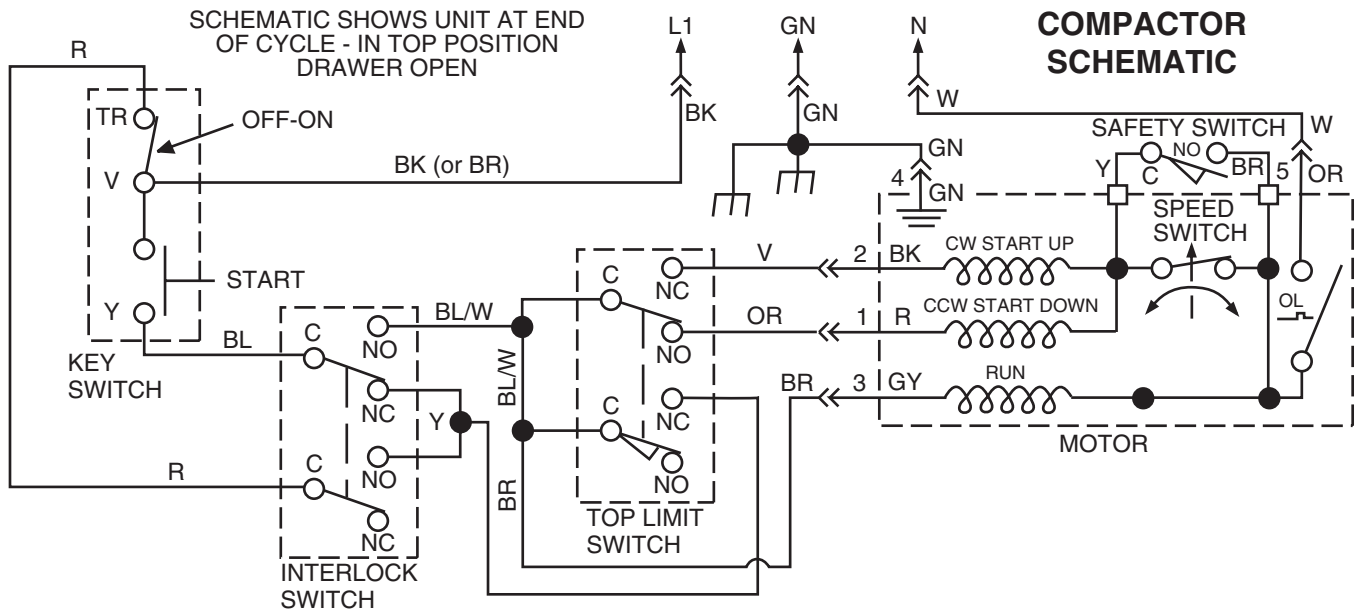

### USAS SYMBOLS

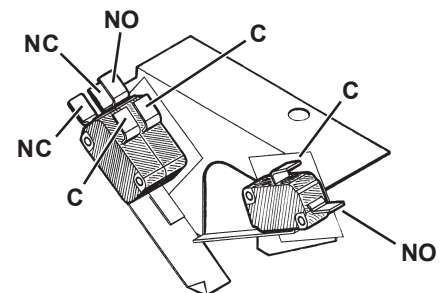
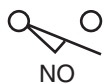
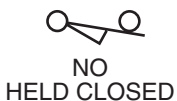
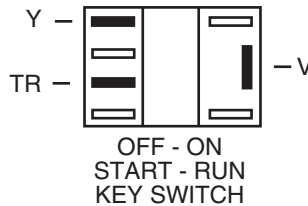
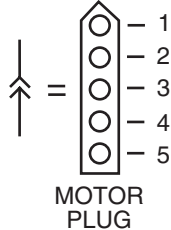



# BROAN®

MODELS 1050L-C,  
1051L-C, 1055-K, 1059-C

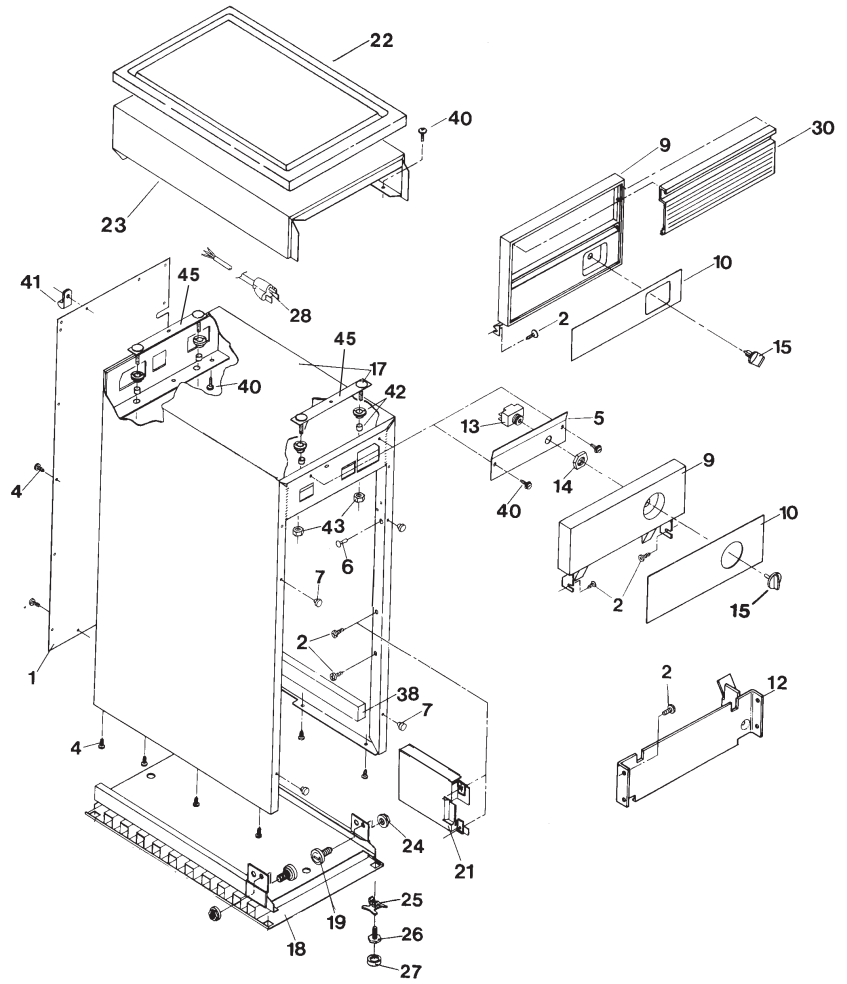

| ITEM NO. | PART NO. | DESCRIPTION |
|----------|----------|-------------|
|          |          |             |

# BROAN®

MODELS 1050L-C,  
1051L-C, 1055-K, 1059-C

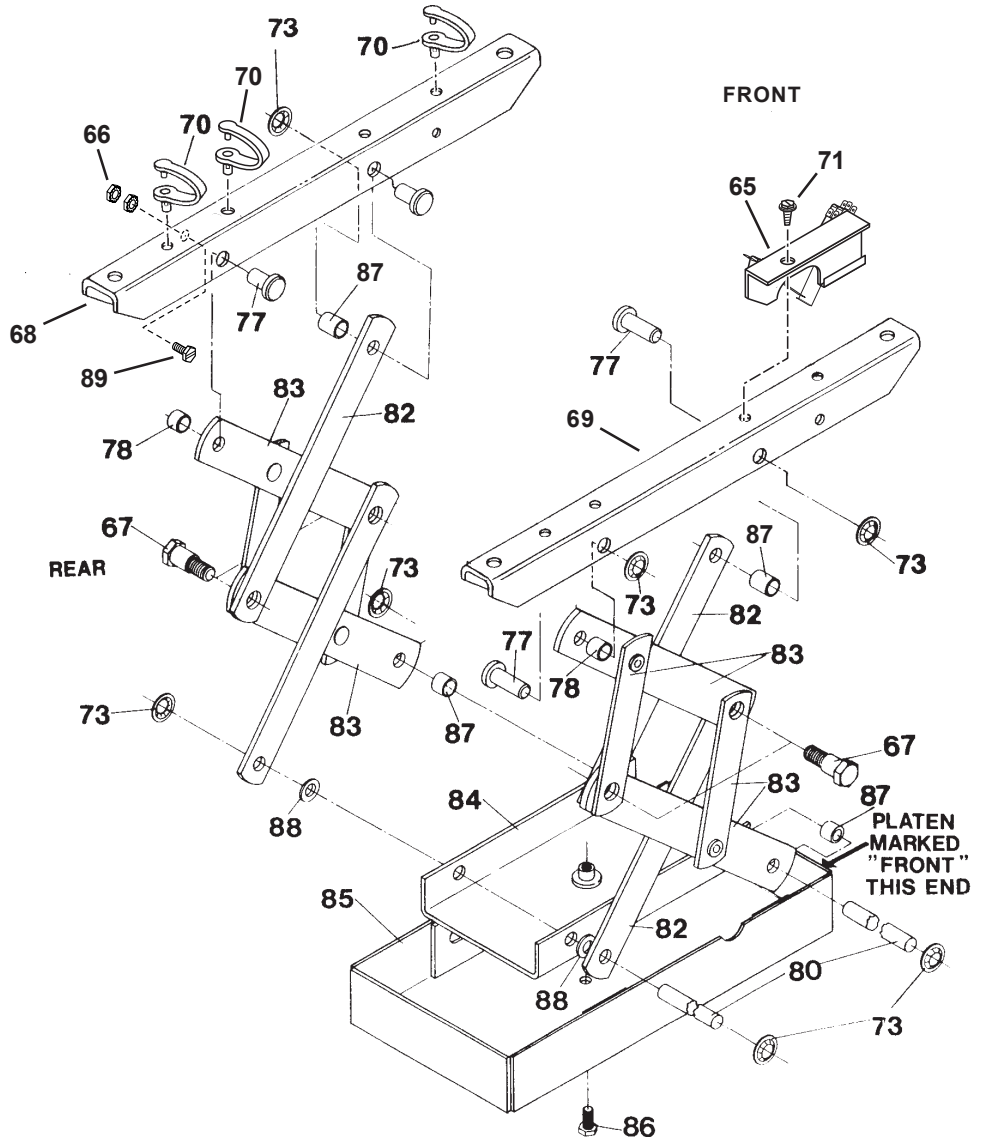

| ITEM NO. | PART NO. | DESCRIPTION |
|----------|----------|-------------|
|          |          |             |

# BROAN®

MODELS 1050L-C,  
1051L-C, 1055-K, 1059-C

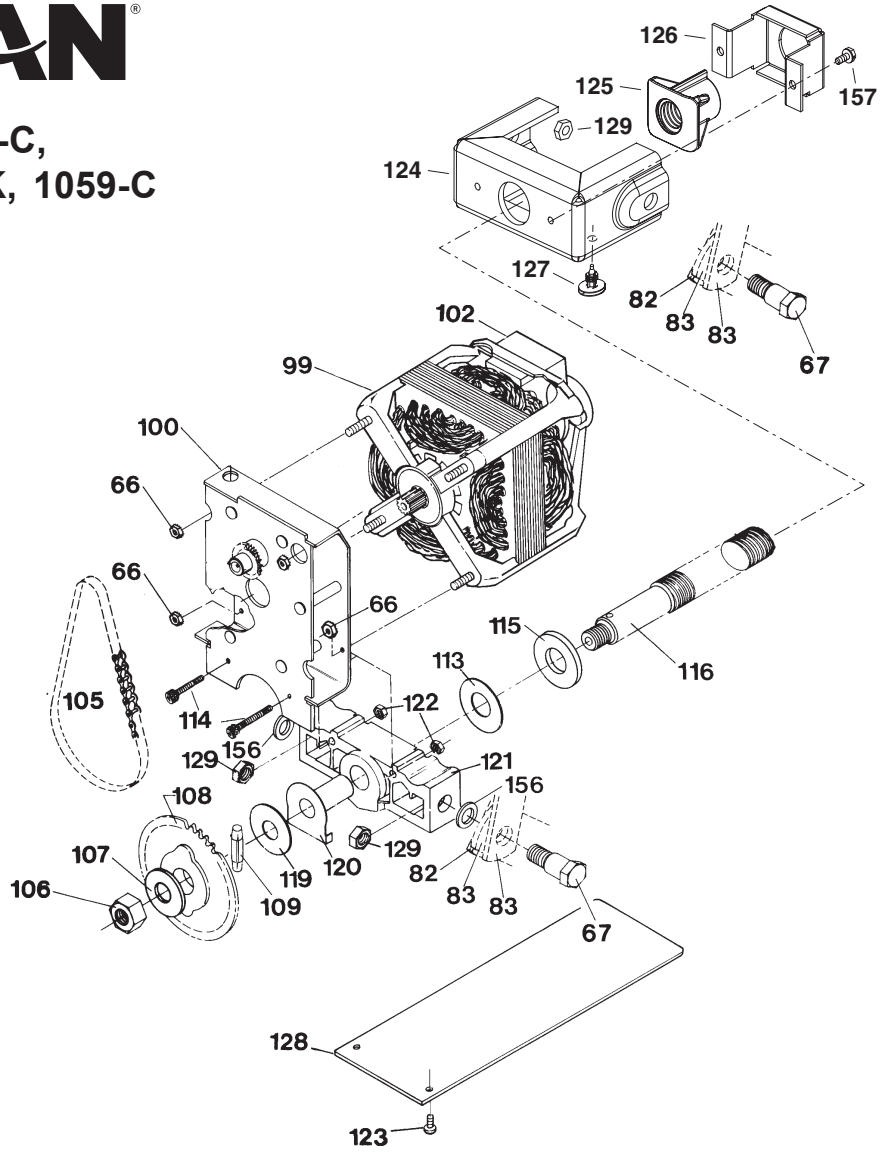

| ITEM NO. | PART NO. | DESCRIPTION |
|----------|----------|-------------|
|          |          |             |

# BROAN®

MODELS 1050L-C,  
1051L-C, 1055-K, 1059-C

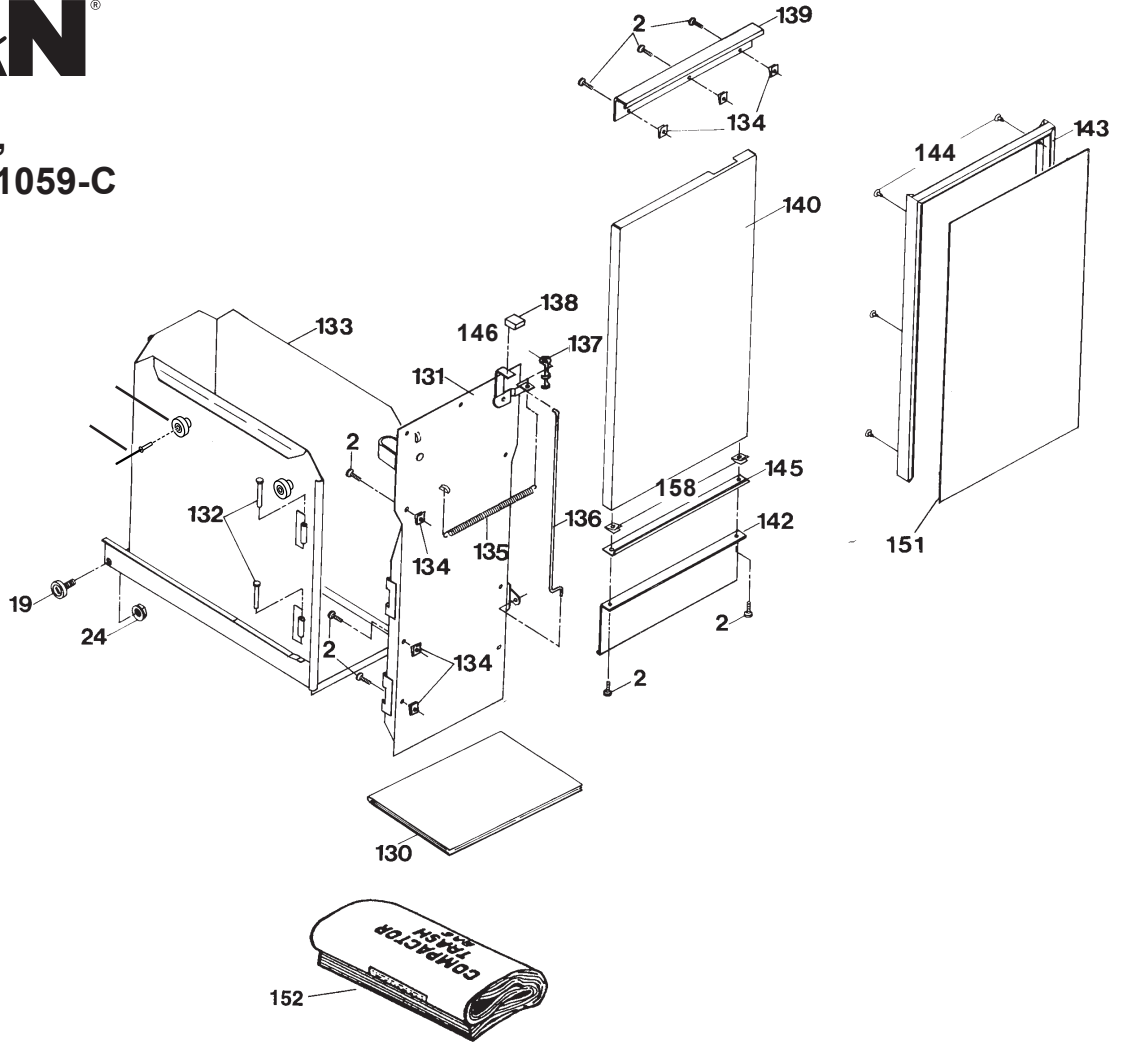

| ITEM NO. | PART NO. | DESCRIPTION |
|----------|----------|-------------|
|          |          |             |

## Free Manuals Download Website

<http://myh66.com>

<http://usermanuals.us>

<http://www.somanuals.com>

<http://www.4manuals.cc>

<http://www.manual-lib.com>

<http://www.404manual.com>

<http://www.luxmanual.com>

<http://aubethermostatmanual.com>

Golf course search by state

<http://golfingnear.com>

Email search by domain

<http://emailbydomain.com>

Auto manuals search

<http://auto.somanuals.com>

TV manuals search

<http://tv.somanuals.com>