

OWNERS MANUAL

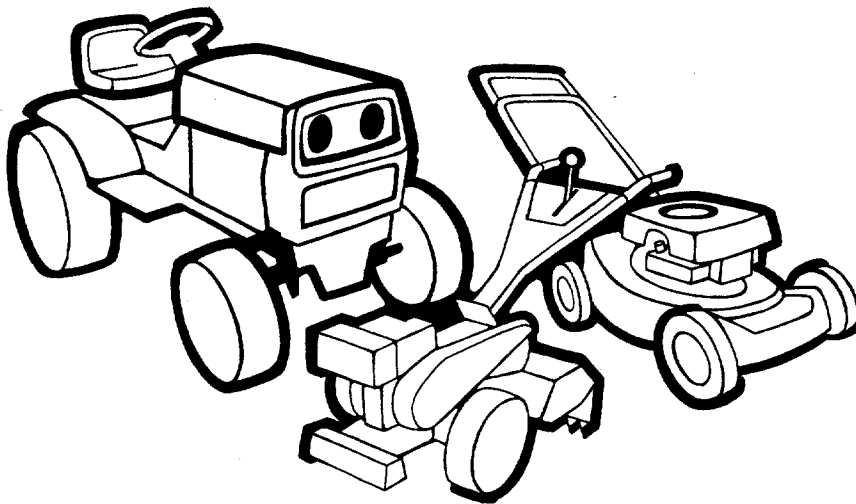

**22" Hi-Wheel
Self-Propelled
Rotary Mower**

**ASSEMBLY
OPERATION
MAINTENANCE
PARTS LIST**

**Model Number
124-553-000**

**Important:
Read Safety Rules and
Instructions Carefully**

Thank you for purchasing an
American built product.

INDEX

| | | | |
|--------------------------------|---|------------------------------|------------|
| Safe Operation Practices | 3 | Maintenance | 10 |
| Assembly Instructions | 4 | Off-Season Storage | 12 |
| Controls | 7 | Trouble Shooting Chart | 13 |
| Operation | 7 | Illustrated Parts | 14, 16, 18 |
| Adjustments | 8 | Repair Parts Lists | 15, 17, 19 |
| Lubrication | 9 | Parts Information | Back Cover |

LIMITED WARRANTY

For one year from the date of original retail purchase, MTD PRODUCTS INC will either repair or replace, at its option, free of charge, F.O.B. factory or authorized service firm, any part or parts found to be defective in material or workmanship. Transportation charges for the movement of any power equipment unit or attachment are the responsibility of the purchaser. Transportation charges for any parts submitted for replacement under this warranty must be paid by the purchaser unless such return is requested by MTD PRODUCTS INC.

This warranty will not apply to any part which has become inoperative due to misuse, excessive use, accident, neglect, improper maintenance, alterations, or unless the unit has been operated and maintained in accordance with the instructions furnished. This warranty does not apply to the engine, motor, battery, battery charger or component parts thereof. Please refer to the applicable manufacturer's warranty on these items.

This warranty will not apply where the unit has been used commercially.

Warranty service is available through your local authorized service dealer or distributor. If you do not know the dealer or distributor in your area, please write to the Customer Service Department of MTD.

The return of a complete unit will not be accepted by the factory unless prior written permission has been extended by MTD.

This warranty gives you specific legal rights. You may also have other rights which vary from state to state.



This unit is equipped with an internal combustion engine and should not be used on or near any unimproved forest-covered, brush-covered or grass-covered land unless the engine's exhaust system is equipped with a spark arrester meeting applicable local or state laws (if any). If a spark arrester is used, it should be maintained in effective working order by the operator.

In the State of California the above is required by law (Section 4442 of the California Public Resources Code). Other states may have similar laws. Federal laws apply on federal lands. A spark arrester muffler is available at your nearest engine authorized service center.



To reduce the potential for any injury, comply with the following safety instructions. Failure to comply with the instructions may result in personal injury.

SAFE OPERATION PRACTICES FOR WALK-BEHIND MOWERS

TRAINING

1. Read this owner's manual carefully in its entirety before attempting to assemble or operate this machine. Be completely familiar with the controls and the proper use of this machine before operating it. Keep this manual in a safe place for future and regular reference and for ordering replacement parts.
2. Your rotary mower is a precision piece of power equipment, not a plaything. Therefore, exercise extreme caution at all times.
3. Never allow children to operate a power mower. Only persons well acquainted with these rules of safe operation should be allowed to use your mower.
4. Keep the area of operation clear of all persons, particularly small children and pets. Stop engine when they are in the vicinity of your mower. Although the area of operation should be completely cleared of foreign objects, an object may have been overlooked and could be accidentally thrown by the mower in any direction and cause serious personal injury to the operator or any others allowed in the area.

PREPARATION

1. Thoroughly inspect the area where the equipment is to be used. Remove all stones, sticks, wire, bones and other foreign objects which could be picked up and thrown by the mower in any direction and cause serious personal injury to the operator or any others allowed in the area.
2. Do not operate equipment when barefoot or wearing open sandals. Always wear substantial footwear.
3. Do not wear loose fitting clothing that could get caught on the mower.
4. Check the fuel before starting the engine. Gasoline is an extremely flammable fuel. Do not fill the gasoline tank indoors, while the engine is running, or while the engine is still hot. Wipe off any spilled gasoline before starting the engine as it may cause a fire or explosion.
5. Disengage the self-propelled mechanism or drive clutch on units so equipped before starting the engine.
6. The blade control handle is a safety device. Never attempt to bypass its operation. Doing so makes the safety device inoperative and may result in personal injury through contact with the rotating blade. The blade control handle must operate easily in both directions.
7. Never attempt to make a wheel or cutting height adjustment while the engine is running.
8. Mow only in daylight or in good artificial light.
9. Never operate the equipment in wet grass. Always be sure of your footing. A slip and fall can cause serious personal injury. Keep a firm hold on the handle and walk, never run.

OPERATION

1. Do not change the engine governor settings or overspeed the engine. Excessive engine speeds are dangerous.
2. Do not put hands or feet near or under rotating parts. Keep clear of the discharge opening at all times as the rotating blade can cause injury.
3. Stop the blade when crossing gravel drives, walks or roads.
4. After striking a foreign object, stop the engine, remove the wire from the spark plug, and thoroughly inspect the mower for any damage. Repair the damage before restarting and operating the mower.
5. If the equipment should start to vibrate abnormally, stop the engine and check immediately for the cause. Vibration is generally a warning of trouble.
6. Shut the engine off and wait until the blade comes to a complete stop before removing the grass catcher or unclogging the chute. The cutting blade continues to rotate for a few seconds after the engine is shut off. Never place any part of the body in the blade area until you are sure the blade has stopped rotating.
7. Before cleaning, repairing or inspecting, make certain the blade and all moving parts have stopped. Disconnect the spark plug wire, and keep the wire away from the spark plug to prevent accidental starting.
8. Do not run the engine indoors.
9. Mow across the face of slopes, never up-and-down. Exercise extreme caution when changing direction on slopes. Do not mow excessively steep slopes. Always be sure of your footing. A slip and fall can cause serious personal injury.
10. Always disconnect electric mowers (line operated) before cleaning, repairing or adjusting.
11. Never operate mower without proper guards, plates or other safety protective devices in place.

MAINTENANCE AND STORAGE

1. Check the blade and engine mounting bolts at frequent intervals for proper tightness.
2. Keep all nuts, bolts, and screws tight to be sure the equipment is in safe working condition.
3. Never store the equipment with gasoline in the tank inside of a building where fumes may reach an open flame or spark. Allow the engine to cool before storing in any enclosure.
4. To reduce fire hazard, keep the engine free of grass, leaves, or excessive grease.
5. Check the grass catcher bag frequently for wear or deterioration. For safety protection, replace only with new bag meeting original equipment specifications.



This unit is shipped WITHOUT GASOLINE or OIL. After assembly, see separate engine manual for proper fuel and engine oil recommendations.

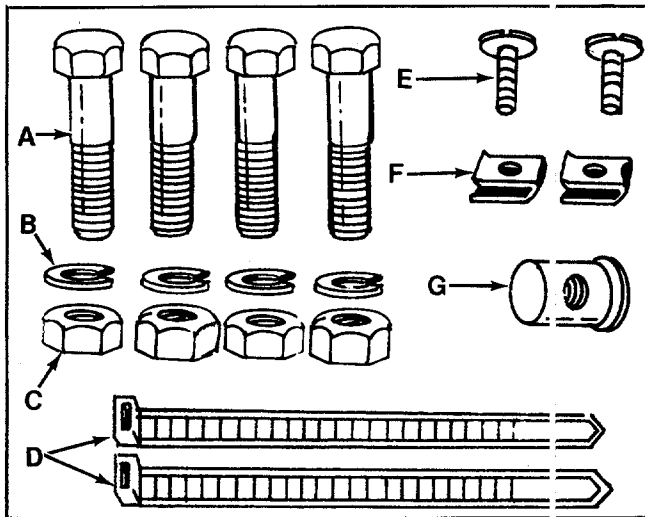

FIGURE 1.

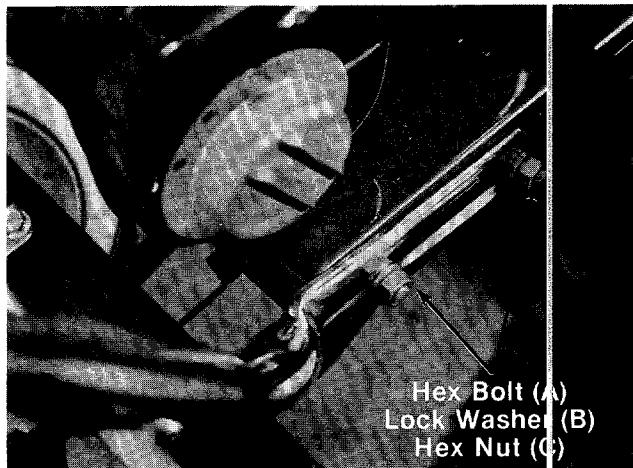

FIGURE 2.

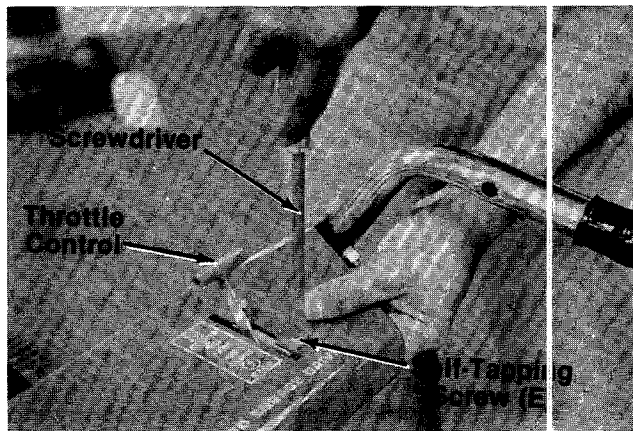

FIGURE 3.

ASSEMBLY INSTRUCTIONS



Reference to right or left hand side of the mower is observed from the operating position.

1. Remove the lawn mower, loose parts, hardware pack and literature from the carton. Make certain all parts and literature have been removed before the carton is discarded.
2. Extend the throttle control assembly and lay on the floor. Be careful not to bend or kink control wire.

← Contents of Hardware Pack:

- A (4) Hex Bolts 5/16-24 x 1.25" Long
- B (4) Lock Washers 5/16" I.D.
- C (4) Hex Nuts 5/16-24 Thread
- D (2) Cable Ties
- E (2) Self-Tapping Screws .50" Long
- F (2) Speed Nuts
- G (1) Ferrule

Loose Parts in Carton:

- Handle Assembly
- Drive Clutch Control Rod

HANDLE ASSEMBLY

1. Line up the holes in the handles with the holes in the frame. Secure with hex bolts (A), lock washers (B) and hex nuts (C). See figure 2.
- ← 2. Start all four nuts and bolts by hand, then tighten securely.
2. Tighten the carriage bolts and nuts which hold the handle panel to the handles, **except** for the upper carriage bolt on the left hand handle. Leave this bolt loose until after the blade clutch control cable is installed.

THROTTLE CONTROL INSTALLATION

- Place the speed nuts (F), flat side up, onto the throttle control. Place throttle control lever up through the hole in the handle panel. Secure with
- ← self-tapping screw (E) as shown in figure 3.

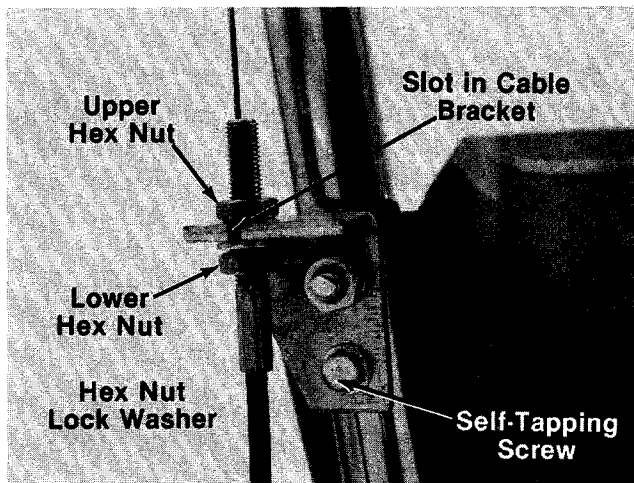

FIGURE 4.

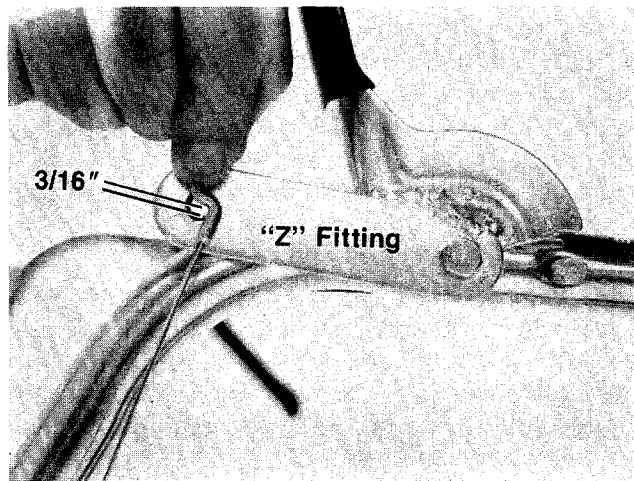

FIGURE 5.

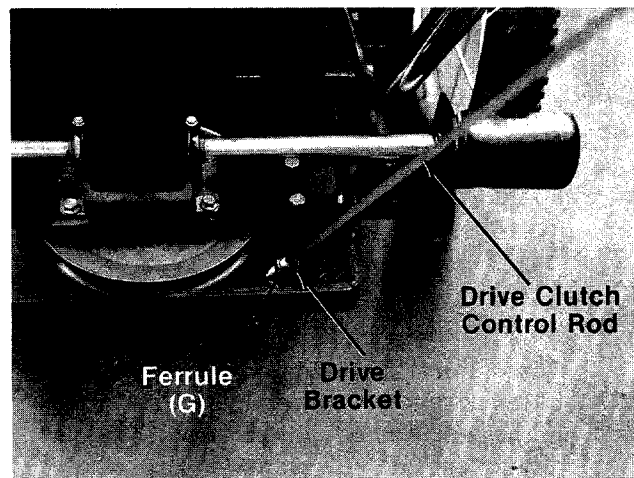

FIGURE 6.

BLADE CLUTCH CONTROL CABLE INSTALLATION

1. The blade clutch control cable is attached to the unit. Remove the hex nut from the threaded end of the clutch control cable casing, and slide the nut up the cable.
2. Slip the cable into the slot in the cable bracket, which is located behind the left hand handle. See figure 4. Slide the threaded end of the cable casing up through the bracket. Rethread the hex nut onto the end of the cable casing a few turns. See figure 4.
3. Place the clutch grip on the left handle in the raised position. Hold the "Z" end of the cable against the clutch grip as shown in figure 5. Adjust the lower hex nut (underneath the cable bracket) so that the middle of the "Z" fitting is $3/16$ " above the bottom of the hole on the clutch grip as shown in figure 5.
4. Tighten the upper hex nut against the cable bracket.
5. Remove the self-tapping screw from the cable bracket. Remove the hex nut and lock washer from the carriage bolt, then remove the cable bracket. See figure 4.
6. Hook the "Z" end of the cable into the hole on the clutch grip. Place the cable bracket in position on the handle so there will be **no bend or kink in the cable when the clutch grip is in the engaged position** (against the handle). Secure with hex nut, lock washer and self-tapping screw.



CAUTION

The final adjustment of the blade clutch control cable must be made before the engine is started. Final adjustment will be covered on page 6.

7. Secure cable to handle with cable ties (D). Cut off excess end of cable ties.

DRIVE CLUTCH CONTROL ROD INSTALLATION

1. Remove hairpin cotter and clevis pin which secure clutch grip to the right hand handle. See figure 7. Remove clutch grip.
2. Place ferrule (G) in position on drive bracket. See figure 6. Thread clutch control rod through ferrule until approximately $1-3/8$ " of threads show below ferrule. See figure 6.

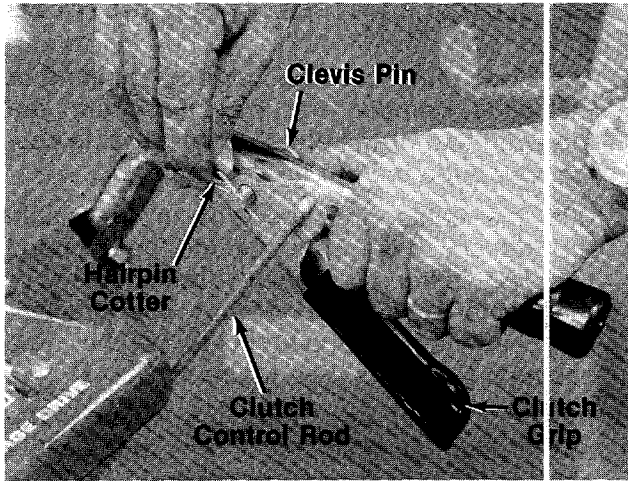

FIGURE 7.

- Hook other end of clutch control rod into clutch grip. Secure clutch grip to handle with clevis pin and hairpin cotter. See figure 7.



CAUTION

Final adjustment of the clutch rod must be made before the engine is started. Final adjustment is covered in next section.

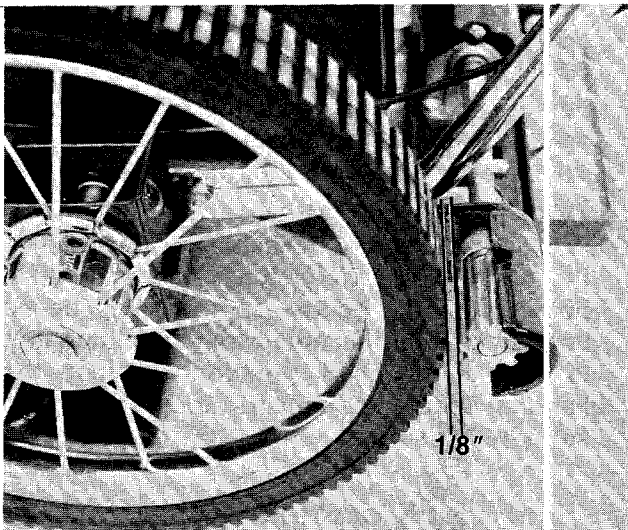

FIGURE 8.

FINAL ADJUSTMENTS

Drive Clutch Adjustment

(Make this adjustment with the engine off.)

- With the drive clutch grip released as shown in figure 7, there should be a minimum clearance of 1/8" between the drive pinions and wheels. See figure 8. With the clutch engaged (clutch grip squeezed), the pinions should engage solidly into the tread of the wheels.

If adjustment is needed, remove the hairpin cotter and clevis pin. Remove the clutch grip. If there is not 1/8" of clearance, unthread the control rod from the ferrule a few turns. If the pinions do not engage solidly into the wheels, thread the control rod further into the ferrule.

Reassemble the clutch grip and check the adjustment. Repeat as necessary.

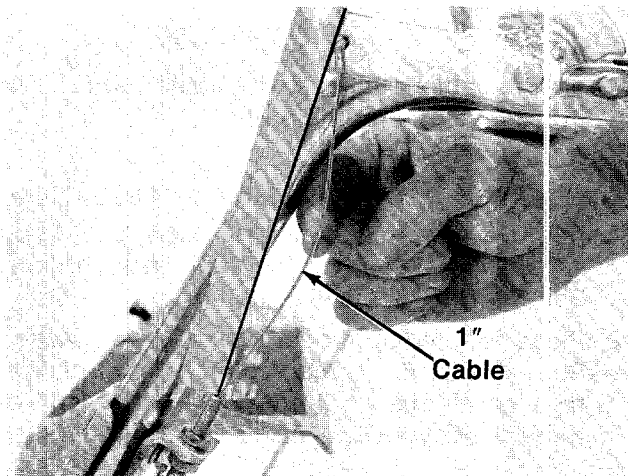

FIGURE 9.

Blade Clutch Adjustment

- With the clutch grip in the released (raised) position, the blade clutch control cable should have approximately 1" deflection as shown in figure 9.



WARNING

There must be slack in the blade clutch cable when the clutch grip is in the released position. Periodically adjust the cable as necessary to maintain the slack.

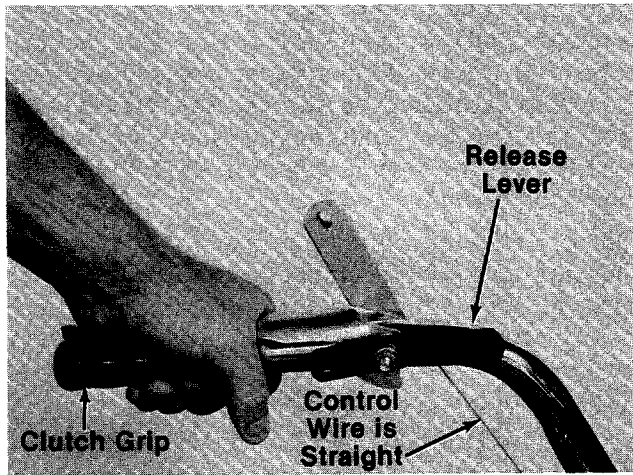

FIGURE 10.

Push the release lever to free the clutch grip, then squeeze the clutch grip against the handle. The control cable should now be straight. See figure 10.

The blade clutch adjustment may be checked as follows.

1. Disconnect the spark plug wire from the spark plug and ground it against the engine block.
2. Block the wheels of the unit.
3. Remove the spindle cover from the frame.
4. With the blade clutch grip released, pull the recoil starter rope several times. The belt and blade pulley on top of the deck should not turn.
5. Reassemble the spindle cover.

NOTE

If the belt slips when cutting heavy grass, the cable could be too loose and should be readjusted as specified.

CONTROLS

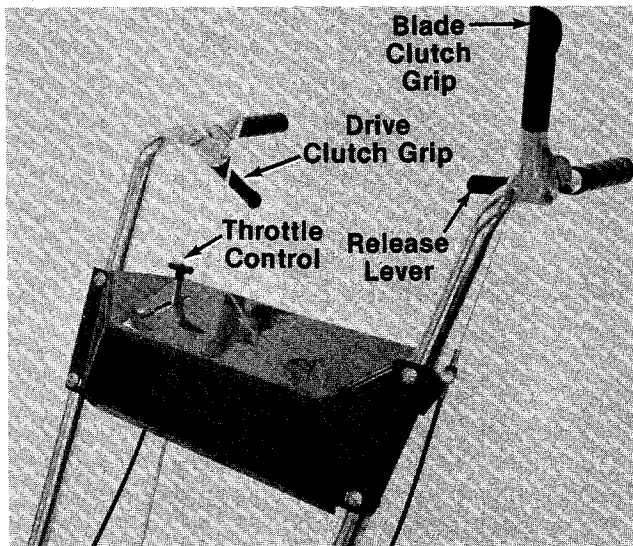

FIGURE 11.

THROTTLE CONTROL

The throttle control is located on the right hand side of handle panel. It controls engine speed. See figure 11.

DRIVE CLUTCH GRIP

The drive clutch grip is located on the right handle of the mower. Squeezing the clutch grip engages the drive pinions into the wheels. Release the clutch handle and the forward motion of the mower stops. You must release the clutch handle to make a turn. See figure 11.

BLADE CLUTCH GRIP

The blade clutch grip is located on the left handle. Push the release lever to free the blade clutch grip, then squeeze the clutch grip against the handle to engage the blade. Release the grip to stop the blade from turning. See figure 11.

OPERATIONS

Caution

Do Not Operate Mower Unless This Guard Or Entire Grasscatcher Is In Its Proper Place.



FIGURE 12.

Keep hands and feet away from the chute area on cutting deck. See figure 12.

BEFORE STARTING

1. Check the lubricant level in the gear box. It must be maintained half full at all times and should be checked prior to each mowing. See the lubrication section of this manual.
2. Check the final adjustment section of the Assembly Instructions to be sure the drive clutch and blade clutch controls are working properly.
3. Fill sump with oil as instructed in the separate engine manual packed with your unit.
4. Fill fuel tank using clean, fresh, lead-free, low-lead, or regular grade leaded gasoline. Fill tank completely!
DO NOT MIX OIL WITH GASOLINE.

TO START ENGINE

1. Be certain both clutch grips are in the disengaged position (released). See figure 11.
2. Move the throttle control to the "CHOKE" position. See figure 11.
3. From the left side, opposite the discharge chute and with one foot on the deck, grasp the recoil starter handle and pull out rapidly. Allow the rope to rewind slowly. If the engine does not start after two or three tries, move the throttle control to the "FAST" position and try again.
4. After the engine starts, move the throttle control into the "FAST" position.

TO STOP

1. The engine is stopped by moving the throttle control lever to "STOP" position.
2. The blade is stopped by releasing the blade clutch grip, located on the left handle
3. Ground movement is stopped by releasing the drive clutch grip, located on the right handle.
4. Disconnect spark plug wire from the spark plug and ground to prevent accidental starting while equipment is unattended.

USING YOUR ROTARY MOWER

Be sure that lawn is clear of stones, sticks, wire, or other objects which could damage lawn mower or engine. Such objects could be accidentally thrown by the mower in any direction and cause serious personal injury to the operator and others. Appropriate clothing should be worn when cutting brush or heavy weeds. Safety shoes and safety glasses are highly recommended.

Operate a new engine at intermediate speeds and light load for the first few hours as you would a new automotive engine.

For best results, do not cut wet grass because it tends to stick to the underside of the mower, preventing proper discharge of grass clippings, and could cause you to slip and fall. New grass, thick grass or wet grass may require a narrower cut. Blade speed should be adjusted to the condition of the lawn.

The best mowing pattern is one that allows the clippings to discharge towards the uncut part of the lawn. This permits recutting of the clippings to further pulverize them. When cutting high weeds, discharge towards cut portion, then recut at right angles to first direction.

For best results, cut off one-third or less of the total length of the grass. Lawn should be cut in the fall as long as there is growth.

This mower is designed to be operated at full throttle to give you the best cut. However, unit should be run at slower speeds until operator is thoroughly familiar with controls.



IMPORTANT

If you strike a foreign object, stop the engine. Remove wire from spark plug, thoroughly inspect the mower for any damage, and repair the damage before restarting and operating the mower. Extensive vibration of the mower during operation is an indication of damage. The unit should be promptly inspected and repaired.

ADJUSTMENTS



CAUTION

Do not at any time make any adjustment to lawn mower without first stopping engine and disconnecting spark plug wire.

DRIVE AND BLADE CLUTCH ADJUSTMENTS

To adjust the drive clutch and blade clutch, refer to the final adjustment section of the assembly instructions.

Clearance between drive pinion and drive wheel should be approximately 1/8" when drive clutch grip is released. Refer to figure 8. Excess clearance will cause premature belt wear. Adjust cable as necessary.

THROTTLE

If adjustment becomes necessary, the throttle control wire assembly can be reset as follows:

1. Loosen, but do not remove, screw securing throttle control wire assembly at engine. See figure 13.
2. Move throttle control lever on handle to "CHOKE" position.
3. Move control lever on engine to full open position. Retighten screw to secure throttle control wire assembly.

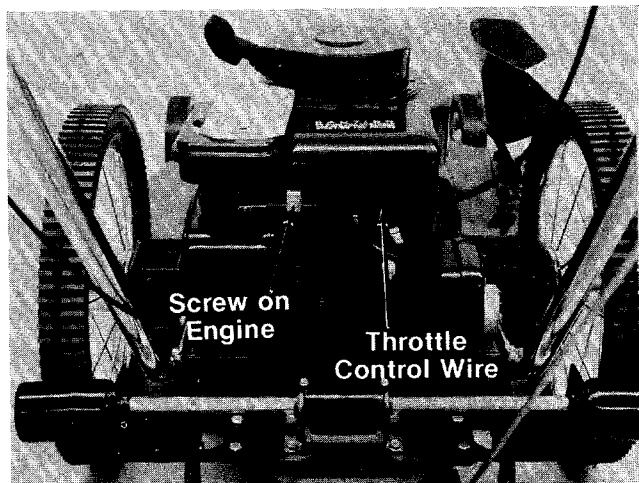

FIGURE 13.

CARBURETOR ADJUSTMENTS



WARNING

If any adjustments are made to the engine while the engine is running (e.g. carburetor), disengage all clutches and blades. Keep clear of all moving parts and be careful of heated surfaces and muffler.

Minor carburetor adjustment may be required to compensate for differences in fuel, temperature, altitude and load.

If carburetor adjustment is required, refer to the separate engine manual packed with your unit.

HEIGHT ADJUSTMENT



WARNING

Before changing the cutting height, stop the engine and disconnect the spark plug wire.

Unscrew the rear axle bolt and place it in one of the four height adjustment holes. The Belleville washer must be installed exactly as shown in figure 14 (cupped side against the frame).

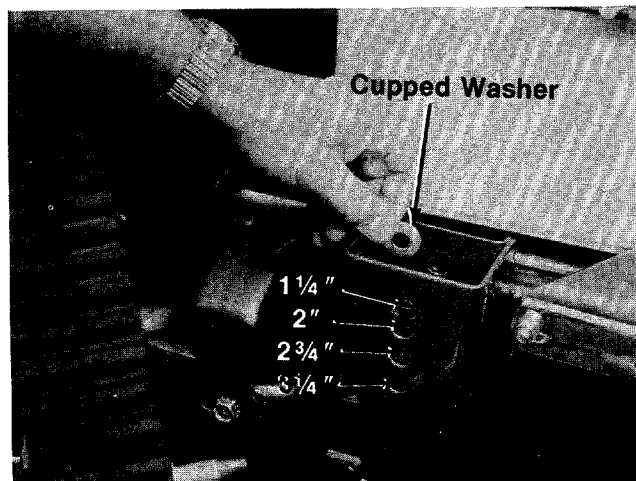

FIGURE 14.

Adjust the front wheels in the same manner. All wheels must be in the same relative position. See figure 15.

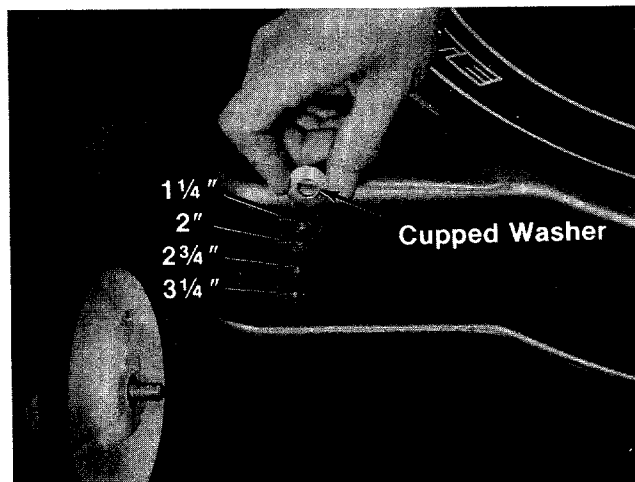

FIGURE 15.

LUBRICATION



Always stop engine and disconnect spark plug wire before cleaning, lubricating, or doing any kind of work on the lawn mower.

1. **Wheels**—Front and rear wheel bearings are ball bearing. Lubricate periodically with a few drops of light oil. To lubricate the rear wheels, remove the oil caps and add several drops of oil.

Also, if the wheels are removed for any reason, lubricate the surface of the axle bolt and the inner surface of the wheel with light oil. A 4 oz. plastic bottle of light oil lubricant is available. Order part number 737-0170. Engine oil may also be used.

2. **Throttle**—Periodically lubricate throttle control lever and throttle wire assembly with a few drops of light oil for ease of operation.
3. **Engine**—Follow engine manual for lubrication instructions.
4. **Gear Box**—Check lubricant in the gear box. This must be maintained half full at all times and should be checked prior to each mowing. The gear box is packed at the factory with Alduralube Heavy or Temprite No. 2. It is suggested that this or an equivalent type and quality fibrous high heat wheel bearing grease be used in maintaining this mechanism.
5. **Chute Deflector**—The torsion spring and pivot point should be lubricated periodically with light oil to prevent any rust or binding. Deflector must work freely.
6. **Clutch Control**—Lubricate the pivot point on the clutch handle, the cable and the "Z" fitting on end of cable at least once a season with light oil. The control must operate freely in both directions.
7. **Pinion Bearings**—Lubricate with a few drops of engine oil once a season. See figure 16.

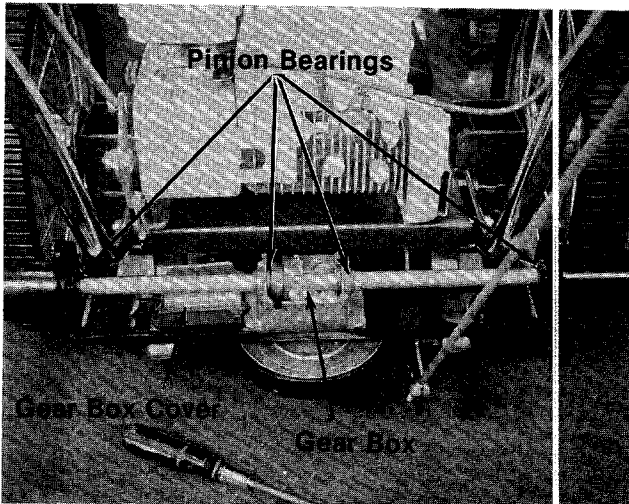

FIGURE 16.

8. The blade spindle bearings are sealed and require no further lubrication.
9. Lubricate the idler brake bracket assembly at the pivot point with an automotive chassis grease at least once a season. Refer to page 16, reference number 32.
10. Lubricate all other linkage after every 25 hours of operation with light oil.

MAINTENANCE

CUTTING BLADE

A. Removal for Sharpening or Replacement



Be sure to disconnect and ground the spark plug wire before working on the cutting blade to prevent accidental engine starting.

1. Remove the large bolt and lock washer which holds the scalp plate, blade and adapter to the blade spindle. See figure 17.

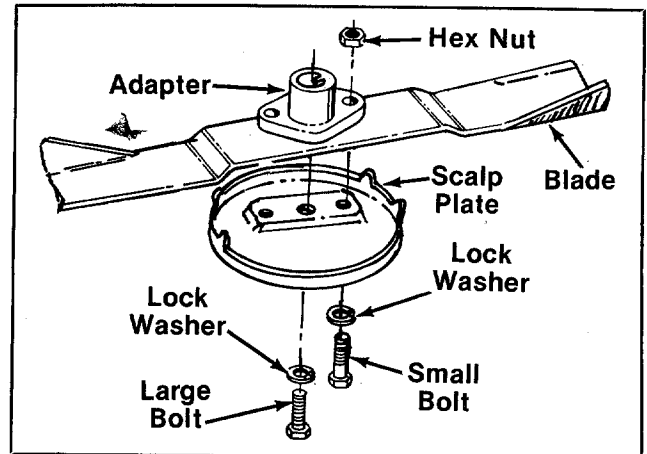

FIGURE 17.

2. Remove the scalp plate, blade and adapter from the spindle.
3. If the scalp plate, blade or blade adapter needs replacing, remove the two small bolts, lock washers and nut which hold the scalp plate and blade to the adapter.



Periodically inspect the blade adapter for cracks, especially if you strike a foreign object. Replace when necessary.

B. Sharpening

Remove the cutting blade by following the directions of the preceding section.

When sharpening the blade, follow the original angle of grind as a guide. It is **extremely important** that each cutting edge receives an equal amount of grinding to prevent an unbalanced blade. An unbalanced blade will cause excessive vibration when rotating at high speeds, may cause damage to the mower, and could break, causing personal injury.

The blade can be tested for balance by balancing it on a round shaft screwdriver. Remove metal from the heavy side until it balances evenly. See figure 18.

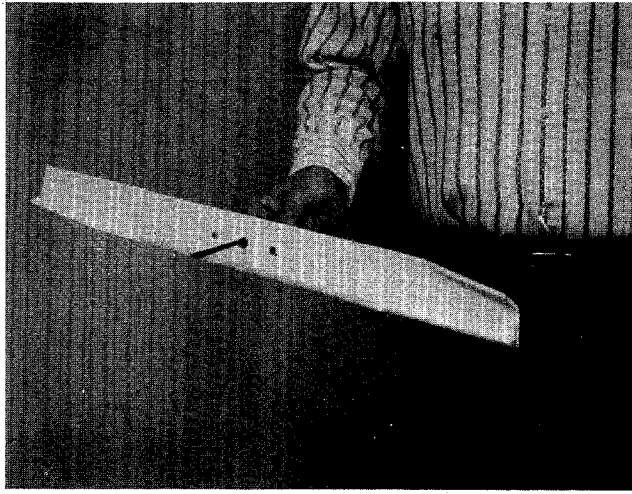

FIGURE 18.



NOTE

It is recommended that the blade always be removed from the adapter for the best test of balance.

C. Reassembly

Before reassembling the scalp plate, blade and the blade adapter to the unit, lubricate the blade spindle and the inner surface of the blade adapter with light oil. Lubricating the bolt holes, bolts and inner surface of the nuts with light oil is also recommended. A 4 oz. plastic bottle of light oil lubricant is available. Order part number 737-0170. Engine oil may also be used.

When replacing the blade, be sure to install the blade with the side of the blade marked "Bottom" (or with part number) facing the ground when the mower is in the operating position.

Blade Mounting Torque

3/8" Dia. Bolt 375 in. lb. min., 450 in. lb. max.

5/16" Dia. Bolt 150 in. lb. min., 250 in. lb. max.

To insure safe operation of your unit, ALL nuts and bolts must be checked periodically for correct tightness.

DECK

The underside of mower deck should be cleaned after each period of use as grass clippings, leaves, dirt and other matter will accumulate. This accumulation of grass clippings, etc., is undesirable as it will invite rust and corrosion and may cause an uneven discharge of grass clippings at the next cutting.

The deck may be cleaned by tilting the mower forward or on its side and scraping clean with a suitable tool or by washing with a stream of water from a garden hose.



Do not direct the stream of water at a hot engine as damage to the engine may result.

ENGINE OIL

Check oil level before starting and after every 5 hours of operation or each period of use. ADD oil as necessary to keep level FULL TO POINT OF OVERFLOWING. Before removing oil fill plug, clean area around plug to prevent dirt from entering oil fill hole. Engine should be in a level position when checking oil.

Change oil after first 5 hours of operation. Thereafter, change every 25 hours. Change oil while engine is warm. Oil may be drained through oil drain at the base of the engine. Be sure unit is level so that oil drains completely. Oil capacity 1 3/4 pints. See figure 19.

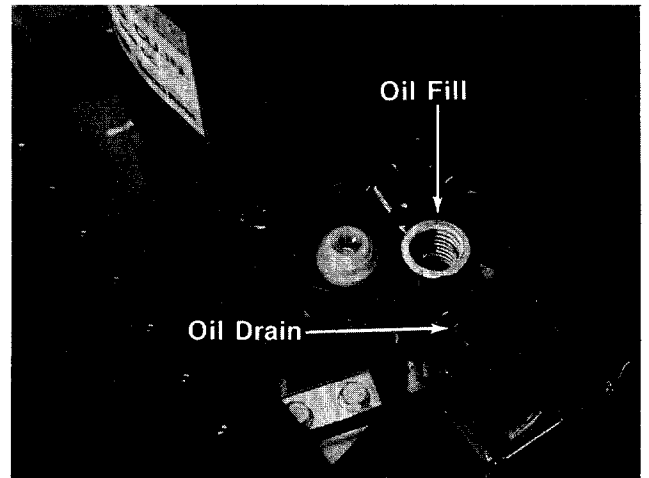

FIGURE 19.

AIR CLEANER

Clean air cleaner every 25 hours under normal conditions. Clean every few hours under extremely dusty conditions. Poor engine performance and flooding usually indicates that the air cleaner should be serviced. To service the air cleaner, refer to the separate engine manual packed with your unit.

SPARK PLUG

The spark plug should be cleaned and the gap reset once a season. Spark plug replacement is recommended at the start of each mowing season; check engine manual for correct plug type and gap specification.

BELT REPLACEMENT

Drive Belt (See Figure 20)

1. Disconnect the spark plug wire and ground it against the engine block.

2. Remove the bottom frame assembly.
3. Remove the pulley from the pinion shaft. Do not misplace pulley key on pinion shaft.
4. Remove and replace the drive belt.
5. When replacing the pulley, be sure the key is in place on the pinion shaft and that the small hub of the pulley faces up.

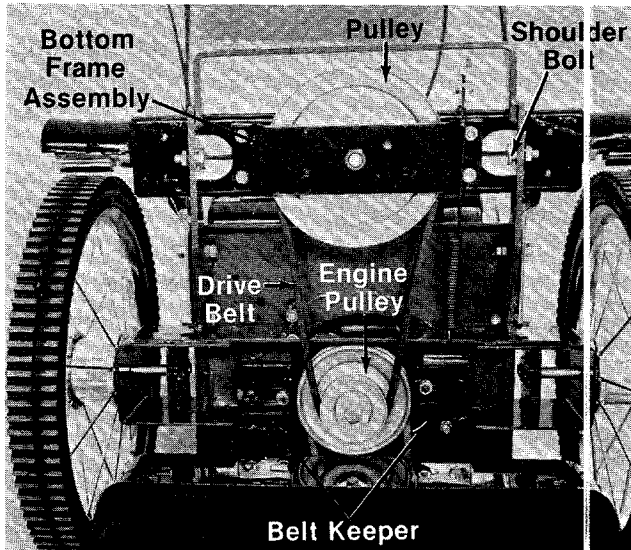

FIGURE 20.

6. Replace the bottom frame assembly.

Blade Belt

1. Unhook the spring. Remove the shoulder bolts, lock washers and hex nuts which secure the drive mechanism to the frame. See figure 20.
2. Remove the drive belt from the engine pulley. See figure 20.
3. Remove the belt keeper from each side of the engine pulley. See figure 20.
4. Remove the spindle cover from the frame.
5. Remove shoulder bolts (belt keepers) at blade pulley. See figure 21.
6. Remove hex lock nut at brake bracket assembly. See figure 21.
7. Remove brake spring, flat washer and brake return spring from brake bracket assembly. See figure 21.
8. Remove the idler pulley from the idler brake bracket assembly. See figure 21.
9. Remove shoulder bolt (belt keeper) next to stationary idler. See figure 21.
10. Remove and replace the belt. Reassemble in reverse order.

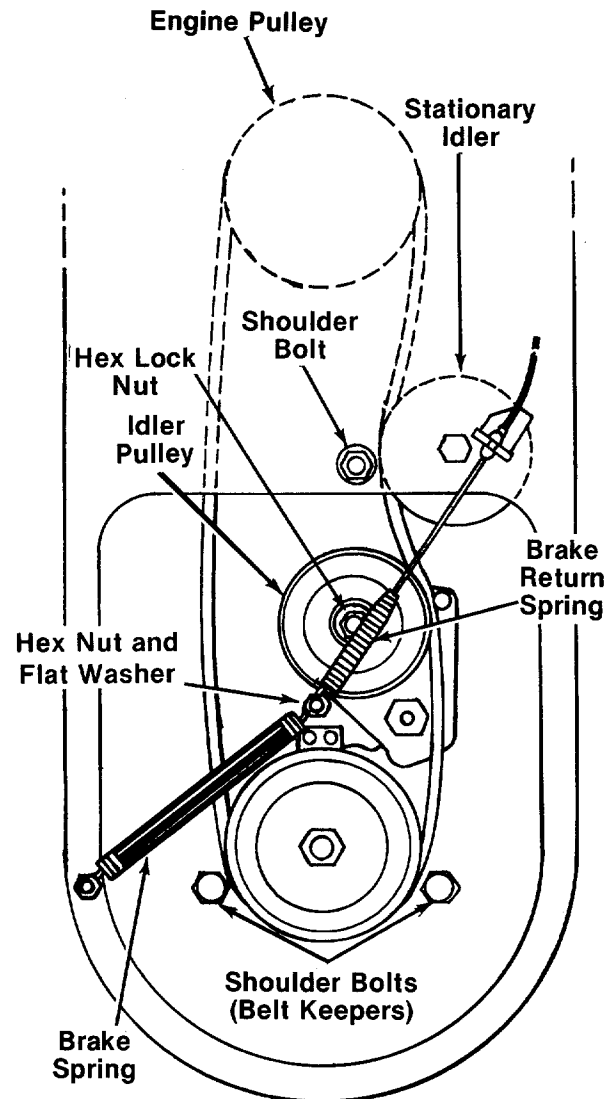

FIGURE 21.

OFF-SEASON STORAGE

The following steps should be taken to prepare lawn mower for storage.

1. Clean and lubricate mower thoroughly as described in the lubrication instructions.
2. Refer to engine manual for correct engine storage instructions.
3. Coat mower's cutting blade with chassis grease to prevent rusting.
4. Store mower in a dry, clean area.



CAUTION

When storing any type of power equipment in an unventilated or metal storage shed, care should be taken to rust proof the equipment. Using a light oil or silicone, coat the equipment, especially springs, bearings and cables.

Trouble Shooting Chart

| Problem | Cause | Remedy |
|---|---|--|
| 1 Engine fails to start | <p>A Check fuel tank for gas</p> <p>B Spark plug lead wire disconnected</p> <p>C Throttle control lever not in the starting position</p> <p>D Faulty spark plug</p> <p>E Carburetor improperly adjusted, engine flooded</p> <p>F Old stale gasoline</p> | <p>A Fill tank if empty.</p> <p>B Connect lead wire.</p> <p>C Move throttle lever to start position.</p> <p>D Spark should jump gap between control electrode and side electrode. If spark does not jump, replace the spark plug.</p> <p>E Remove spark plug, dry the plug, crank engine with plug removed, and throttle in off position. Replace spark plug and lead wire and resume starting procedures.</p> <p>F Drain and refill with fresh gasoline.</p> |
| 2 Hard starting or loss of power | <p>A Spark plug wire loose</p> <p>B Carburetor improperly adjusted</p> <p>C Dirty air cleaner</p> | <p>A Connect and tighten spark plug wire.</p> <p>B Adjust carburetor. See separate engine manual.</p> <p>C Clean air cleaner as described in separate engine manual.</p> |
| 3 Operation erratic | <p>A Dirt in gas tank</p> <p>B Dirty air cleaner</p> <p>C Water in fuel supply</p> <p>D Vent in gas cap plugged</p> <p>E Carburetor improperly adjusted</p> | <p>A Remove the dirt and fill tank with fresh gas.</p> <p>B Clean air cleaner as described in separate engine manual.</p> <p>C Drain contaminated fuel and fill tank with fresh gas.</p> <p>D Clear vent or replace gas cap.</p> <p>E Adjust carburetor. See separate engine manual.</p> |
| 4 Occasional skip (hesitates) at high speed | <p>A Carburetor idle speed too slow</p> <p>B Spark plug gap too close</p> <p>C Carburetor idle mixture adjustment improperly set</p> | <p>A Adjust carburetor. See separate engine manual.</p> <p>B Adjust to .030".</p> <p>C Adjust carburetor. See separate engine manual.</p> |
| 5 Idles poorly | <p>A Spark plug fouled, faulty, or gap too wide</p> <p>B Carburetor improperly adjusted</p> <p>C Dirty air cleaner</p> | <p>A Reset gap to .030" or replace spark plug.</p> <p>B Adjust carburetor. See separate engine manual.</p> <p>C Clean air cleaner as described in separate engine manual.</p> |
| 6 Engine overheats | <p>A Carburetor not adjusted properly</p> <p>B Air flow restricted</p> <p>C Engine oil level low</p> | <p>A Adjust carburetor. See separate engine manual.</p> <p>B Remove blower housing and clean as described in separate engine manual.</p> <p>C Fill crankcase with the proper oil.</p> |
| 7 Excessive vibration | <p>A Cutting blade loose or unbalanced</p> <p>B Bent blade</p> | <p>A Tighten blade and adapter. Balance blade.</p> <p>B Replace blade.</p> |

Note: For repairs beyond the minor adjustments listed above contact your local authorized service dealer.

Model 553

Meets CPSC Blade Safety Requirements

Lot/Model

Mfg. Date

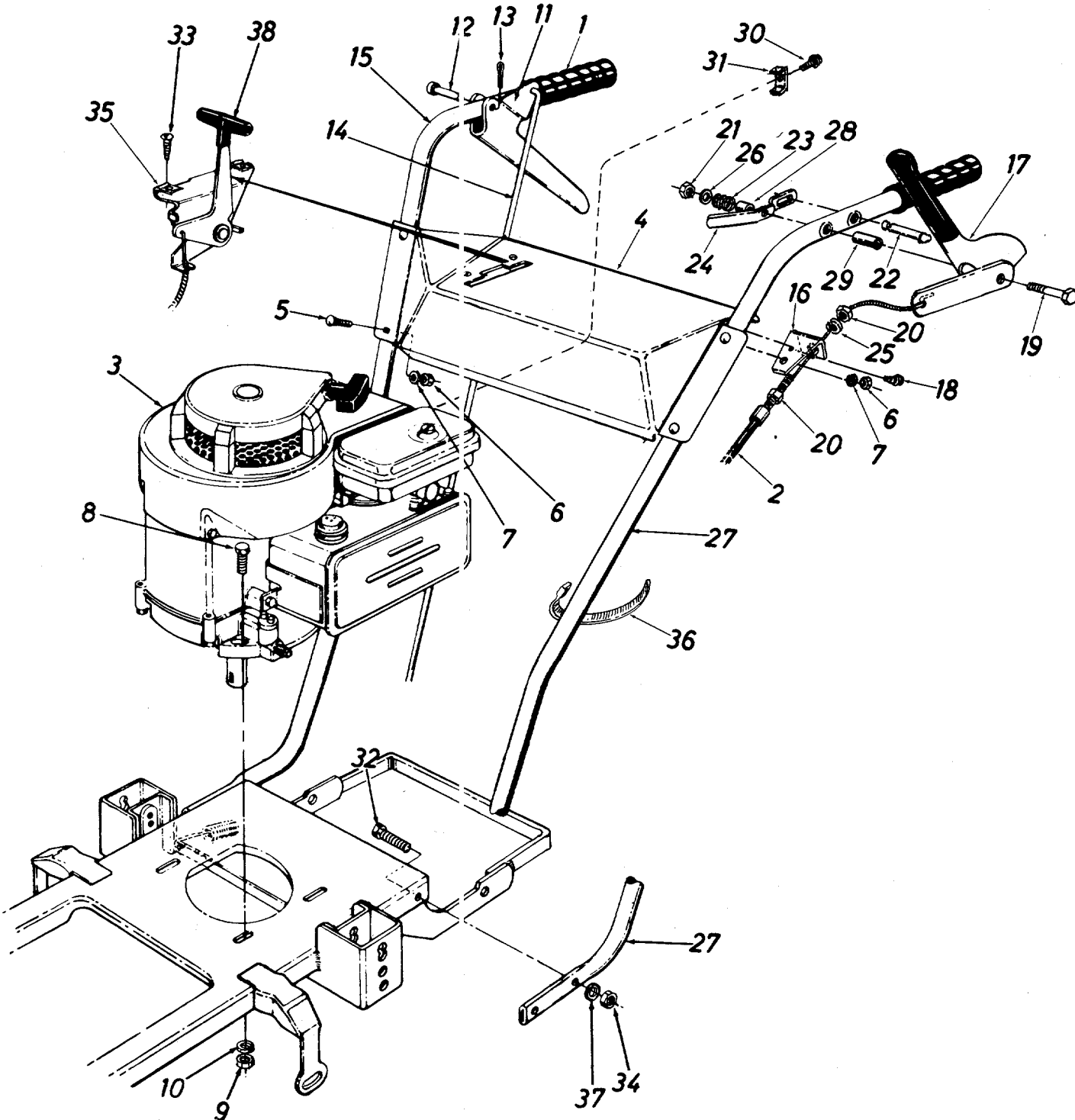

Model 553

PARTS LIST FOR MODEL 553 ROTARY MOWER

| REF. NO. | PART NO. | COLOR CODE | DESCRIPTION | NEW PART |
|----------|------------------------|------------|--|----------|
| 1 | 720-0204 | | Grip | |
| 2 | 746-0507 | | Clutch Cable—39.0" | N |
| 3 | — | | Engine | |
| 4 | 15336 | | Handle Panel | |
| 5 | 710-0458 | | Carr. Bolt 5/16-18 x 1.75" Lg.* | |
| 6 | 712-0267 | | Hex Nut 5/16-18 Thd.* | |
| 7 | 736-0119 | | L-Wash. 5/16" I.D.* | |
| 8 | 710-0158 | | Hex Bolt 5/16-24 x 1.25" Lg.* | |
| 9 | 712-0123 | | Hex Nut 5/16-24 Thd.* | |
| 10 | 736-0170 | | L-Wash. 5/16" I.D. | |
| 11 | 12921 | | Clutch Grip Ass'y. | |
| 12 | 711-0415 | | Clevis Pin .375" Dia. | |
| 13 | 714-0104 | | Intern. Cotter Pin 5/16" Dia. | |
| 14 | 747-0165 | | Drive Control Rod | |
| 15 | 749-0560 | | Handle—R.H. | |
| 16 | 16047 | | Clutch Cable Brkt. | N |
| 17 | 15402 15853 | | Blade Clutch Grip Ass'y. | |
| 18 | 710-0599 | | Hex Wash. S-Tap Scr. 1/4-20 x .50" Lg. | |
| 19 | 710-0641 | | Hex Bolt 1/4-20 x 2.25" Lg.* | |
| 20 | 712-0256 | | Hex Jam Nut 5/16-24 Thd. | |
| 21 | 712-0291 | | Hex Cent. L-Nut 1/4-20 Thd. | |
| 22 | 711-0719 | | Lock Pin | |
| 23 | 732-0334 | | Compression Spring | |
| 24 | 732-0441 | | Lockout Spring | |
| 25 | 736-0119 | | L-Wash. 5/16" I.D.* | |
| 26 | 736-0498 | | Internal Tooth L-Wash. | |
| 27 | 749-0561 | | Handle—L.H. | |
| 28 | 750-0565 | | Spacer .44" Lg. | |
| 29 | 750-0566 | | Spacer 1.03" Lg. | |
| 30 | 710-0429 | | Hex AB-Tap Scr. #10 x .38" Lg. | |
| 31 | 751-0333 | | Casing Clamp | |
| 32 | 710-0158 | | Hex Bolt 5/16-24 x 1.25" Lg.* | |
| 33 | 710-0224 | | Hex Wash. Hd. AB-Tap Scr. #10 x .50" Lg. | |
| 34 | 712-0123 | | Hex Nut 5/16-24 Thd.* | |
| 35 | 712-0344 | | Speed Nut 10Z U-Type | |
| 36 | 725-0157 | | Cable Tie | |
| 37 | 736-0119 | | L-Wash. 5/16" I.D.* | |
| 38 | 746-0378 | | Throttle Control | |

*For faster service obtain standard nuts, bolts and washers locally. If these items cannot be obtained locally, order by part number and size as shown on parts list.

(462—Red Flake) When ordering parts, if color or finish is important, use the appropriate color code shown at left. (e.g. Red Flake Finish—11992 (462).)



This instruction manual covers various models and all specifications shown do not necessarily apply to your model. Specifications subject to change without notice or obligation.

NOTE: The engine is not under warranty by the mower manufacturer... If repairs or service is needed on the engine, please contact your nearest authorized engine service outlet. Check the "Yellow Pages" of your telephone book under "Engines—Gasoline."

**Find It Fast
In The
Yellow Pages**

Model 553

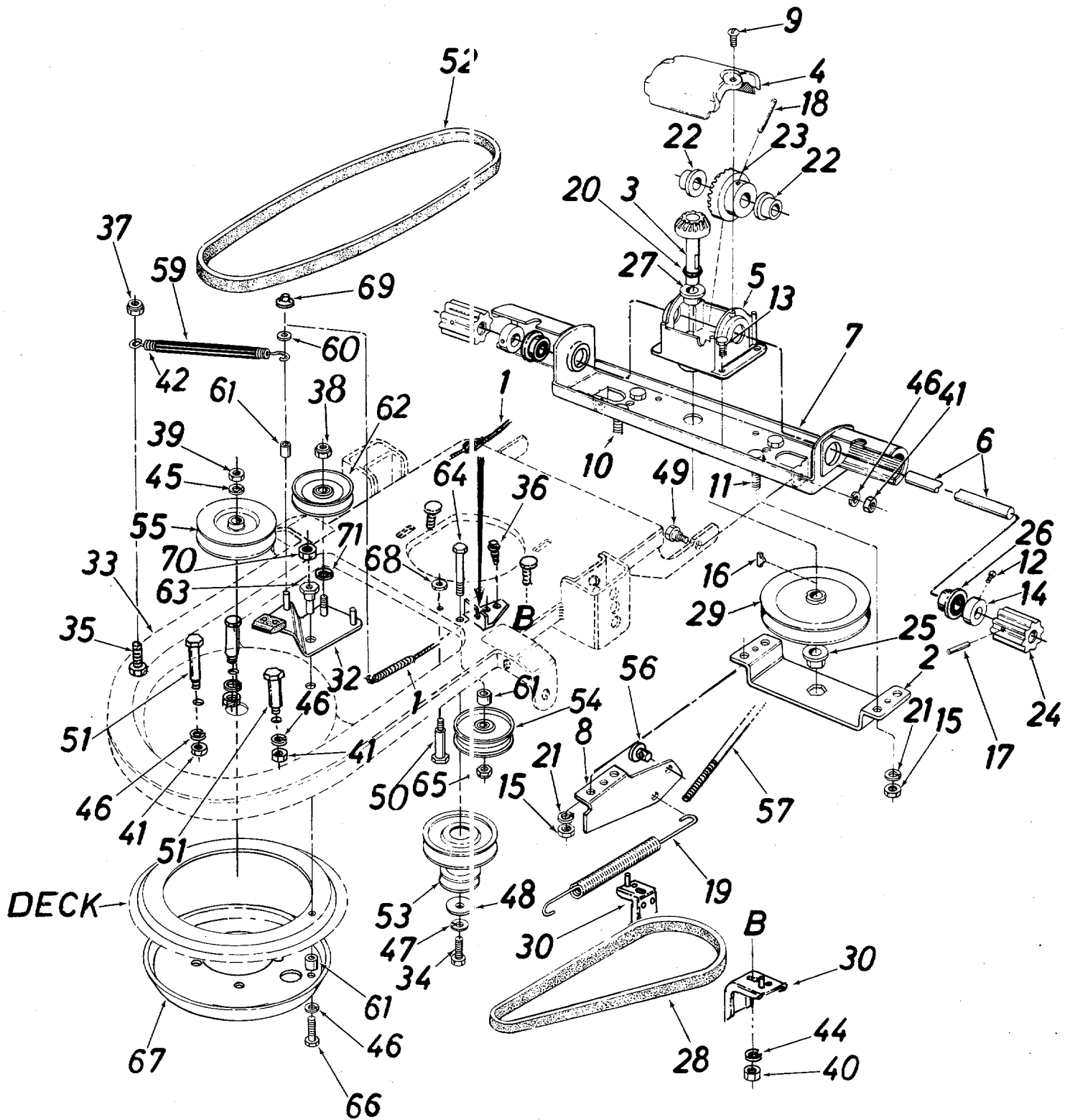

Lubricate with 2 oz. High Temp. 450°F. Grease.
Order Part No. 737-0120.

Model 553

PARTS LIST FOR MODEL 553 ROTARY MOWER

| REF. NO. | PART NO. | COLOR CODE | DESCRIPTION | NEW PART | REF. NO. | PART NO. | COLOR CODE | DESCRIPTION | NEW PART |
|----------|---------------------|------------|---|----------|----------|----------|------------|---|----------|
| 1 | 746-0507 | | Clutch Cable—39.0" | N | 35 | 710-0252 | | Hex Bolt 1/4-20 x .75" Lg.* | |
| 2 | 07112 | | Bottom Frame | | 36 | 710-0776 | | Hex Wash. Hd. AB-Tap Scr. 1/4" x .62" Lg. | |
| 3 | 07957 | | Pinion Ass'y. | | | | | | |
| 4 | 08187 | | Gear Box Cover | | 37 | 712-0107 | | Hex Cent. L-Nut 1/4-20 Thd. | |
| 5 | 08189 | | Gear Box† | | 38 | 712-0116 | | Hex Ins. L-Nut 3/8-24 Thd. | |
| 6 | 08348 | | Drive Shaft | | 39 | 712-0242 | | Hex Jam Nut 5/8-11 Thd. | |
| 7 | 16044 | | Top Drive Frame Ass'y. | N | 40 | 712-0267 | | Hex Nut 5/16-18 Thd.* | |
| 8 | 12587 | | Spring Brkt. | | 41 | 712-0798 | | Hex Nut 3/8-16 Thd.* | |
| 9 | 710-0148 | | Hex Wash. Hd. F-Tap Scr. #8 -32 x .38" Lg. | | 42 | 732-0308 | | Extension Spring | |
| 10 | 710-0206 | | Hex Bolt 1/4-20 x .88" Lg.* | | 44 | 736-0119 | | L-Wash. 5/16" I.D.* | |
| 11 | 710-0252 | | Hex Bolt 1/4-20 x .75" Lg.* | | 45 | 736-0158 | | L-Wash. 5/8" I.D.* | |
| 12 | 710-0421 | | Set Scr. 5/16-18 x .25" Lg. | | 46 | 736-0169 | | L-Wash. 3/8" I.D.* | |
| 13 | 710-0776 | | Hex Wash. Hd. AB-Tap Scr. 1/4" x .62" Lg. | | 47 | 736-0217 | | L-Wash. 3/8" I.D.—H.D. | |
| 14 | 711-0169 | | Collar 5/8" I.D. | | 48 | 736-0235 | | FI-Wash. .406" I.D. x 1.25" O.D. | |
| 15 | 712-0287 | | Hex Nut 1/4-20 Thd.* | | 49 | 738-0143 | | Shld. Bolt .498" Dia. x .340" | |
| 16 | 714-0229 | | #2 Woodruff Key 3/32" x 1/2" Dia. | | 50 | 738-0144 | | Shld. Bolt .498" Dia. x 1.64" | |
| 17 | 715-0150 | | Spring Pin .188" Dia. x 1.12" Lg. | | 51 | 738-0213 | | Shld. Bolt .498" Dia. x 1.450" | |
| 18 | 715-0246 | | Spring Pin Spiral .188" Dia. x 1.25" Lg. | | 52 | 754-0274 | | V-Belt 1/2" x 44.0" Lg. (Blade) | N |
| 19 | 732-0185 | | Extension Spring | | 53 | 756-0404 | | Two Step Engine Pulley | |
| 20 | 735-0193 | | O-Ring | | 54 | 756-0405 | | Flat Idler Pulley | N |
| 21 | 736-0329 | | L-Wash. 1/4" I.D. | | 55 | 756-0392 | | 1/2" V-Pulley .503" I.D. x 4.50" O.D. | |
| 22 | 748-0110 | | Flange Bearing .630" I.D.† | | 56 | 711-0619 | | Adj. Ferrule | |
| 23 | 748-0135 | | Bevel Gear | | 57 | 747-0165 | | Drive Control Rod | |
| 24 | 748-0182 | | Drive Pinion | | 58 | 712-0429 | | Hex Ins. L-Nut 5/16-18 Thd. | |
| 25 | 748-0226 | | Hex Flange Bearing .503" I.D. | | 59 | 731-0675 | | Plastic Tube | N |
| 26 | 748-0138 | | Ball Bearing .630" I.D. | | 60 | 736-0275 | | FI-Wash. .343 I.D. x .687 O.D. x .063 | |
| 27 | 748-0269 | | Hex Flange Bearing .503" I.D. w/Groove† | | 61 | 750-0497 | | Spacer .376 I.D. x .622 O.D. x .44" Lg. | |
| 28 | 754-0146 | | V-Belt 1/2" x 33.0" Lg. (Drive) | | 62 | 756-0293 | | 4.0" Idler Pulley | |
| 29 | 756-0393 | | 1/2" V-Pulley .504" I.D. x 6.5" O.D. | | 63 | 738-0563 | | Shoulder Spacer | |
| 30 | 10426 | | Belt Keeper Ass'y. | | 64 | 710-0539 | | Hex Bolt 3/8-24 x 1.75" Lg.* | |
| 31 | 15093 | | Clutch Cable Brkt. | | 65 | 712-0296 | | Hex L-Nut 3/8-24 Thd. | |
| 32 | 15851 | | Idler Brake Brkt. Ass'y. | N | 66 | 710-0724 | | Hex Bolt 3/8-24 x 1.5" Lg.* | |
| 33 | 15860 | | Frame Ass'y. | N | 67 | 15486 | | Blade Reinforcement Plate | |
| 34 | 710-0152 | | Hex Bolt 3/8-24 x 1.00" Lg.* | | 68 | 712-0181 | | Hex L-Nut 3/8-16 Thd. | |
| | | | | | 69 | 726-0106 | | Push Cap 1/4" | |
| | | | | | 70 | 712-0711 | | Hex Jam Nut 3/8-24 Thd. | |
| | | | | | 71 | 736-0235 | | FI-Wash. .406 I.D. x 1.25 O.D. x .172 Thk. | |

*For faster service obtain standard nuts, bolts and washers locally. If these items cannot be obtained locally, order by part number and size as shown on parts list.

(462—Red Flake) When ordering parts, if color or finish is important, use the appropriate color code shown at left. (e.g. Red Flake Finish—11992 (462).)

†Order Kit 753-0218

The engine is not under warranty by the mower manufacturer. If repairs or service is needed on the engine, please contact your nearest authorized engine service outlet. Check the "Yellow Pages" of your telephone book under "Engines—Gasoline."

Find It Fast
In The
Yellow Pages

Model 553

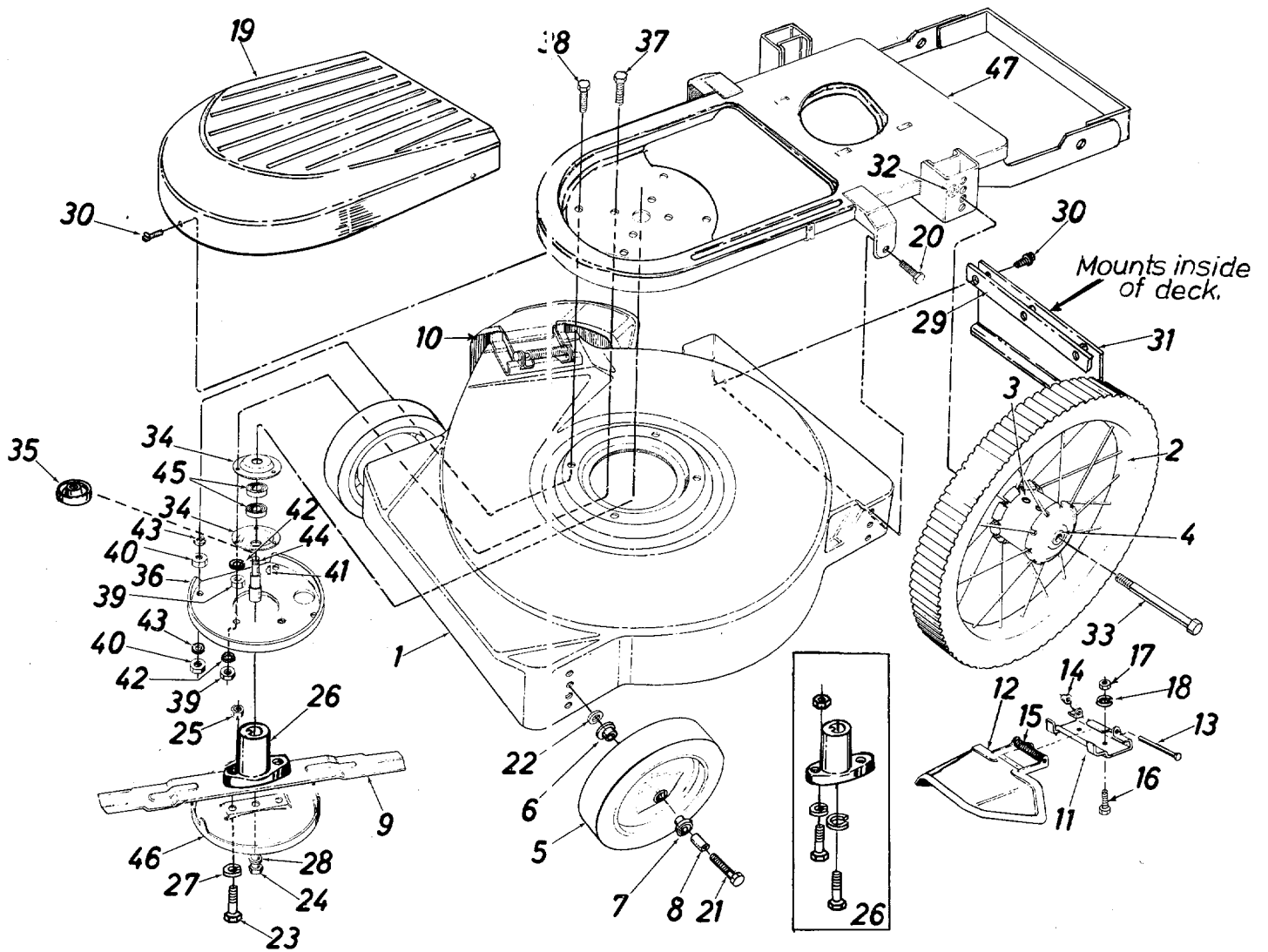

Model 553

PARTS LIST FOR MODEL 553 ROTARY MOWER

| REF. NO. | PART NO. | COLOR CODE | DESCRIPTION | NEW PART | REF. NO. | PART NO. | COLOR CODE | DESCRIPTION | NEW PART |
|----------|----------|------------|--------------------------------|----------|----------|----------|------------|-------------------------------|----------|
| 1 | 14918 | | 22" Deck Ass'y. | N | 23 | 710-0888 | | Hex Bolt 5/16-24 x 1.00" Lg. | |
| 2 | 734-0438 | | 16" Wheel Ass'y. Comp. | | 24 | 710-0331 | | Hex Bolt 3/8-24 x 2.25" Lg. | |
| | 734-0180 | | Rim Only | | 25 | 712-0123 | | Hex Nut 5/16-24 Thd.* | |
| | 734-0391 | | Tire Only | | 26 | 753-0348 | | Blade Adapter Kit | |
| 3 | 718-0132 | | Oil Cap | | 27 | 736-0119 | | L-Wash. 5/16" I.D.* | |
| 4 | 741-0113 | | Ball Bearing | | 28 | 736-0217 | | L-Wash. 3/8" I.D.—H.D. | |
| 5 | 734-0642 | | Wheel Ass'y. Comp. | | 29 | 14836 | | Retaining Strip | |
| | | | 8 x 1.75 (Twinline Tread) | | 30 | 710-0776 | | Hex Wash. Hd. AB-Tap Scr. | |
| | 734-0644 | | Wheel Ass'y. Comp. 8 x 1.75 | | | | | 1/4" x .62" Lg. | |
| | | | (Waffle Tread) | | 31 | 731-0587 | | Rear Flap Ass'y. | |
| 6 | 741-0267 | | Flanged Ball Bearing 3/8" | | 32 | 736-0105 | | Bell-Wash. .400" I.D. x .88" | |
| | | | I.D. | | | | | O.D. | |
| 7 | 741-0484 | | Flanged Ball Bearing 1/2" I.D. | | 33 | 738-0114 | | Rear Axle Bolt | |
| 8 | 750-0434 | | Spacer | | 34 | 08253 | | Bearing Housing | |
| 9 | 742-0125 | | 22" Blade | | 35 | 13703 | | Bearing Shield | |
| 10 | 11679 | | Chute Deflector Ass'y. | | 36 | 15486 | | Blade Reinforcement Plate | |
| | | | Comp. | | 37 | 710-0158 | | Hex Bolt 5/16-24 x 1.25" Lg.* | |
| 11 | 11130 | | Adapter Plate | | 38 | 710-0191 | | Hex Bolt 3/8-24 x 1.25" Lg. | |
| 12 | 11141 | | Deflector Ass'y. | | 39 | 712-0123 | | Hex Nut 5/16-24 Thd.* | |
| 13 | 711-0555 | | Pivot Pin | | 40 | 712-0241 | | Hex Nut 3/8-24 Thd.* | |
| 14 | 726-0106 | | Push Cap 1/4" Rod | | 41 | 714-0365 | | #6 Hi-Pro Key 5/32" x 5/8" | |
| 15 | 732-0253 | | Torsion Spring | | | | | Dia. | |
| 16 | 710-0289 | | Hex Bolt 1/4-20 x .50" Lg.* | | 42 | 736-0119 | | L-Wash. 5/16" I.D.* | |
| 17 | 712-0287 | | Hex Nut 1/4-20 Thd.* | | 43 | 736-0169 | | L-Wash. 3/8" I.D.* | |
| 18 | 736-0329 | | L-Wash. 1/4" I.D.* | | 44 | 738-0552 | | Blade Spindle | |
| 19 | 08295 | | Blade Spindle Cover | | 45 | 749-0919 | | Ball Bearing .787" I.D. x | |
| 20 | 710-0209 | | Hex Sems Scr. 3/8-16 x .62" | | | | | 1.85" O.D. | |
| 21 | 710-0427 | | Hex Bolt 3/8-16 x 2.0" Lg. | | 46 | 07919 | | Scalp Plate | |
| 22 | 736-0105 | | Bell-Wash. .400" I.D. x .88" | | 47 | 15860 | | Frame Ass'y. | N |
| | | | O.D. | | | | | | |

NOTE

The use of any accessory on this Rotary Mower other than those manufactured by the mower manufacturer is **not** recommended.

GRASS CATCHER Model 003 is available as optional equipment for the mower shown in this manual.



WARNING

- DO NOT operate the mower without the entire grass catcher or chute deflector in place.
- DO NOT operate the mower without the protective shield on the rear of the deck in place.

NOTE

Under normal usage bag material is subject to wear and should be checked periodically. Be sure any replacement bag complies with the mower manufacturer's recommendations.

For replacement bags, use only factory authorized replacement bag No. 764-0176.

PARTS INFORMATION

POWER EQUIPMENT PARTS AND SERVICE

Parts and service are available through the authorized service firms listed below. All orders should specify the model number of your unit, part numbers, description of parts and the quantity of each part required.

BRIGGS AND STRATTON, TECUMSEH AND PEERLESS PARTS AND SERVICE

Briggs & Stratton, Tecumseh and Peerless parts and service should be handled by your nearest authorized engine service firm. Check the yellow pages of your telephone directory under the listing **Engines—Gasoline**, Briggs & Stratton or Tecumseh Lauson.

NOTE: If any parts are found to be missing or defective upon assembly of this unit, write to advise the factory so that immediate replacement can be made.

| | |
|---|--------------------------------------|
| ALABAMA | BIRMINGHAM |
| Auto Electric & Carburetor Co. | 2625 4th Ave. S. 5233 |
| ARKANSAS | NORTH LITTLE ROCK |
| Sutton's Lawn Mower Shop | 5301 Roundtop Drive |
| | Box 368, Rt. 4 72117 |
| CALIFORNIA | PORTERVILLE |
| Billious | 75 North D Street 3257 |
| COLORADO | DENVER |
| Spitzer Industrial Products Co. | 6601 N. |
| | Washington St. 80229 |
| FLORIDA | JACKSONVILLE |
| Radco Distributors | 4909 Victor St. |
| | Box 5459 2207 |
| | OPA LOCKA |
| Small Eng. Dist. | 2351 N.W. 147th St. 3054 |
| GEORGIA | EAST POINT |
| East Point Cycle & Key | 2834 Church St. 30344 |
| ILLINOIS | LYONS |
| Keen Edge Co. | 8615 Ogden Ave. 60534 |
| INDIANA | ELKHART |
| Parts & Sales Inc. | 2101 Industrial Pkwy. 46516 |
| IOWA | DUBUQUE |
| Power Lawn & Garden Equip. | 2551 J.F. Kennedy 2001 |
| LOUISIANA | NEW ORLEANS |
| Suhren Engine Co. | 8330 Earhart Blvd. 70118 |
| MARYLAND | TAKOMA PARK |
| Center Supply Co. | 6867 New Hampshire |
| | Ave. 20912 |
| MASSACHUSETTS | SPRINGFIELD |
| Morton B. Collins Co. | 300 Birnie Ave. 01107 |
| MICHIGAN | LANSING |
| Lorenz Service Co. | 2500 S. Pennsylvania 48910 |
| | MOUNT CLEMENS |
| Power Equipment Dist. | 340 Hubbard 48043 |
| MINNESOTA | HOPKINS |
| Hance Distributing Inc. | 420 Excelsior Ave. W. 55343 |
| MISSISSIPPI | BILOXI |
| Biloxi Sales & Service, Inc. | 506 Caillavet St. 39533 |
| MISSOURI | KANSAS CITY |
| Automotive Equip. Service | 3117 Holmes St. 64109 |
| | ST. JOSEPH |
| Ross-Frazier Supply Co. | 8th and Monterey 64503 |
| | ST. LOUIS |
| Henzler, Inc. | 2015 Lemay Ferry Rd. 63125 |
| NEW JERSEY | BELLMAWR |
| Lawnmower Parts Inc. | 717 Creek Rd. 03030 |
| NEW MEXICO | ALBUQUERQUE |
| Spitzer Eng. & Parts | 1023 Third Ave. N.W. 87103 |
| NEW YORK | CARTHAGE |
| Gamble Dist., Inc. | West End Ave. 13619 |

| | |
|--|------------------------------------|
| NORTH CAROLINA | GOLDSBORO |
| Smith Hardware Co. | 515 N. George St. 27530 |
| | GREENSBORO |
| Dixie Sales Company | 335 N. Green 27402 |
| OHIO | CARROLL |
| Stebe's Mid-State Mower Supply | Box 366, 71 High St. 43112 |
| | CLEVELAND |
| Bleckrie, Inc. | 7900 Lorain Ave. 44102 |
| | WADSWORTH |
| National Central | 687 Seville Rd. 44281 |
| | YOUNGSTOWN |
| Burton Supply Co. | 1301 Logan Ave. |
| | Box 929 44501 |
| OKLAHOMA | MUSKOGEE |
| Victory Motors, Inc. | 605 S. Cherokee 74401 |
| OREGON | PORTLAND |
| Kenton Supply Co. | 8216 N. Denver Ave. 97217 |
| PENNSYLVANIA | HARRISBURG |
| EECO Inc. | 4021 N. 6th St. 17110 |
| | PHILADELPHIA |
| Thompson Rubber Co. | 5222-24 N. Fifth St. 19120 |
| | PITTSBURGH |
| Bluemont Co. | 11125 Frankstown Rd. 15235 |
| | PUNXSUTAWNEY |
| Frank Roberts & Sons | R.D. 2 15767 |
| | SCRANTON |
| Scranton Auto Ignition Co. | 1133-35 Wyoming Ave. 18509 |
| TENNESSEE | KNOXVILLE |
| Master Repair Service | 2000 Western Ave. 37921 |
| | MEMPHIS |
| American Sales & Service, Inc. | 3035-43 Bellbrook 38116 |
| TEXAS | DALLAS |
| Marr Brothers, Inc. | 423 E. Jefferson 75203 |
| | FORT WORTH |
| Woodson Sales Corp. | 1702 N. Sylvania 76111 |
| | HOUSTON |
| Bullard Supply Co. | 2409 Commerce St. 77003 |
| | SAN ANTONIO |
| Engine House Inc. | 8610 Botts Lane |
| | P.O. Box 17867 78217 |
| UTAH | SALT LAKE CITY |
| A-1 Engine & Mower Co. | 439 E. 900 So. 84111 |
| VIRGINIA | ASHLAND |
| RBI Corp. | 101 Cedar Ridge Dr. 23005 |
| WASHINGTON | SEATTLE |
| Bailey's Inc. | 1414 14th Ave. 98122 |
| WISCONSIN | APPLETON |
| Automotive Supply Co. | 123 S. Linwood Ave. |
| | P.O. Box 798 54911 |
| | CHILTON |
| Horst Dist. | 444 N. Madison 53014 |

WARRANTY PARTS AND SERVICE POLICY

(0783)

The purpose of warranty is to protect the customer from defects in workmanship and materials, defects which are NOT detected at the time of manufacture. It does not provide for the unlimited and unrestricted replacement of parts. Use and maintenance are the responsibility of the customer. The manufacturer cannot assume responsibility for conditions over which it has no control. Simply put, if it's the manufacturer's fault, it's the manufacturer's responsibility; if it's the customer's fault, it's the customer's responsibility.

CLAIMS AGAINST THE MANUFACTURER'S WARRANTY INCLUDES:

1. Replacement of Missing Parts on new equipment.
2. Replacement of Defective Parts within the warranty period.
3. Repair of Defects within the warranty period.

All claims MUST be substantiated with the following information:

1. Model Number of unit involved.
2. Date unit was purchased or first put into service.
3. Date of failure.
4. Nature of failure.

MTD PRODUCTS INC • P.O. BOX 36900 • CLEVELAND, OHIO 44136

Free Manuals Download Website

<http://myh66.com>

<http://usermanuals.us>

<http://www.somanuals.com>

<http://www.4manuals.cc>

<http://www.manual-lib.com>

<http://www.404manual.com>

<http://www.luxmanual.com>

<http://aubethermostatmanual.com>

Golf course search by state

<http://golfingnear.com>

Email search by domain

<http://emailbydomain.com>

Auto manuals search

<http://auto.somanuals.com>

TV manuals search

<http://tv.somanuals.com>