

# BLUE SEA SYSTEMS

Features and Specifications for  
m-ACR 7601 and Mini Add-A-Battery 7649

## m-ACR Automatic Charging Relay

### Features

- Automatically combines batteries during charging, isolates batteries when discharging
- The Start Isolation option protects electronics from voltage sags and spikes during engine cranking
- Supports alternators up to 65 Amps
- Ignition protected—safe for installation aboard gasoline powered boats
- For 12 or 24 volt systems
- Dual Sensing—senses charging on either battery bank

### LED Status Chart

LED	BATTERY STATUS	REASON
Solid ON	Combined	Charging
Single Flash (15 sec.)	Isolated	Standby
Double Flash	Isolated (Start Isolation)	Start Isolation wire is energized
Triple Flash	Isolated (Under Voltage Lockout)	One or both batteries are below 9.5V (12V System) 19V (24V System)

### Specifications

Intermittent Rating (5 min.)	115A
Continuous Rating	65A
Operating Current (Combine)	90mA
Operating Current (Open)	15mA
Cable Size (to meet current ratings)	6 AWG (16mm <sup>2</sup> )
Maximum Cable Size	1/0 AWG (50mm <sup>2</sup> )
Terminal Stud Size	1/4"-20
Maximum Torque	60 in-lbs (6.8 Nm)

### Relay Contact Position

	12V DC	24V DC
Combine (30 sec.)	13.6V DC	27.2V DC
(2 min.)	13.0 V DC	26.0V DC
Open Low (10 sec.)	12.35V DC	24.7V DC
(30 sec.)	12.75V DC	25.5V DC
Over Voltage Lockout	16.0V DC	--
Under Voltage Lockout	9.5V DC	19.0V DC
Under Voltage Reset	10.0V DC	20.0V DC

### Regulatory

CE marked for Ignition Protection, Meets ISO 8846 and SAE J1171 external ignition protection requirements

Rated IP67—temporary immersion up to 1 meter for 30 minutes

## m-Series, Dual Circuit Plus™ Battery Switch 6011 (Included with 7649 Mini Add-A-Battery)

### Features

- Switches two battery banks simultaneously with one ON/OFF switch while maintaining battery bank isolation, minimizing the risk of a dead start battery
- The COMBINE BATTERIES function parallels two battery banks in the event of a low battery
- Ignition protected—safe for installation aboard gasoline powered boats

### Specifications

Cranking Rating (10 sec.)	1,000 Amps
Cranking Rating (1 min.)	650 Amps
Intermittent Rating (5 min.)	450 Amps
Continuous Rating	300 Amps
Maximum Voltage	32 Volts
Cable Size to Meet Ratings	4/0 AWG (120mm <sup>2</sup> )
Terminal Stud Size	3/8"-16 (M10)
Maximum Torque	120 in-lbs (13.56 Nm)

### Regulatory

CE marked for ignition protection, meets UL1500 and SAE J1171 external ignition protection requirements

Rated IP66—protected against powerful water jets

## Installation Instructions

### m-ACR Automatic Charging Relay 7601

#### m-ACR Mounting

- To avoid corrosion to connecting wires and terminals, mount in a dry and protected location if possible. Avoid locations directly above the battery banks.

#### m-ACR Electrical Connections

- The wiring diagrams illustrated on the back page represent common installations and are not meant to be a guide for wiring a specific vessel.
- The 7601 m-ACR is not intended to carry starting currents. Use a battery switching system with a combine batteries/parallel function if batteries may need to be combined for emergency starting.  
**Caution:** Disconnect battery connections before beginning the installation.

#### m-ACR Voltage Sensing

- The 7601 m-ACR will sense a charge being applied to either battery bank.

Use the wire sizing chart below to select the appropriate wire sizes to prevent overheating the m-ACR.

Wire Size and Fuse Rating Chart			
Charging Amps	Min. Wire Size* (AWG)	Fuse Rating	Min. Wire Size* (Metric)
≤30	#10	40A-50A	6 mm <sup>2</sup>
≤50	#8	60A-65A	10 mm <sup>2</sup>
≤65	#6	90A-100A	16 mm <sup>2</sup>

\* Larger wire sizes may be required to minimize voltage drop in long wire runs. For more information please use the Circuit Wizard at [www.circuitwizard.bluesea.com](http://www.circuitwizard.bluesea.com)

#### m-ACR minimum connections for operation:

- Connect one battery bank positive to one of the 1/4"-20 studs.
- Connect the other battery bank positive to the other 1/4"-20 stud.
- Both positive connections should be made through appropriately sized circuit protection to meet ABYC recommendations. See "Wire Size and Fuse Rating" chart, above, for suggested fuse ratings.
- Connect the quick connect terminal marked **GND** (ground) to the DC system ground through a 10A in-line fuse to prevent fault currents from flowing in this wire.

#### m-ACR optional connection:

##### To enable start isolation:

- Connect a wire from the quick connect terminal marked **SI** (starting isolation) to the terminal or wire running from the start key switch to the starter solenoid (see back for wiring diagram). This connection can be made at the start key switch or at the starter solenoid, but must be to the line that is positive only when cranking. Connection to a line that is positive while the engine is normally running will prevent the charging relay from working properly.

## Installation Instructions

### m-Series, Dual Circuit Plus™ Battery Switch 6011 (Included with 7649 Mini Add-A-Battery)

- Turn all loads off before turning the battery switch to OFF.
- Do not switch to OFF while the engine is running.
- Mount the battery switch in an easily accessible location close to the batteries.
- Attach one 4/0 AWG cable per terminal to meet ratings.
- Terminals must be attached under nut and lock washer. Torque to 120 in-lb (13.56 Nm)

## M-ACR Installation Diagram

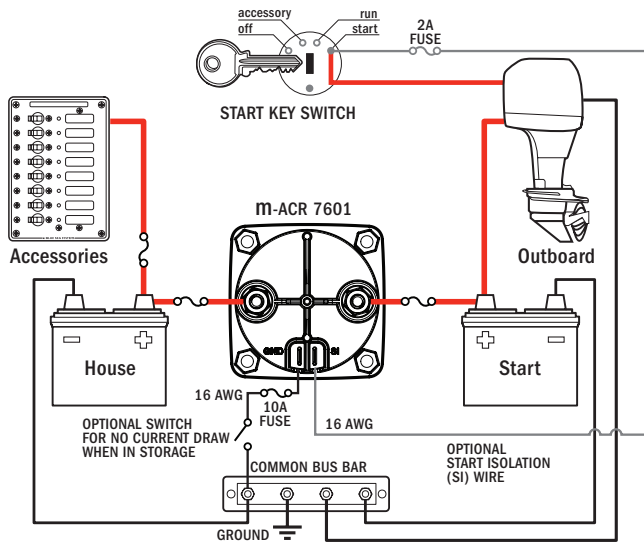

## Mini Add-A-Battery Installation Diagram

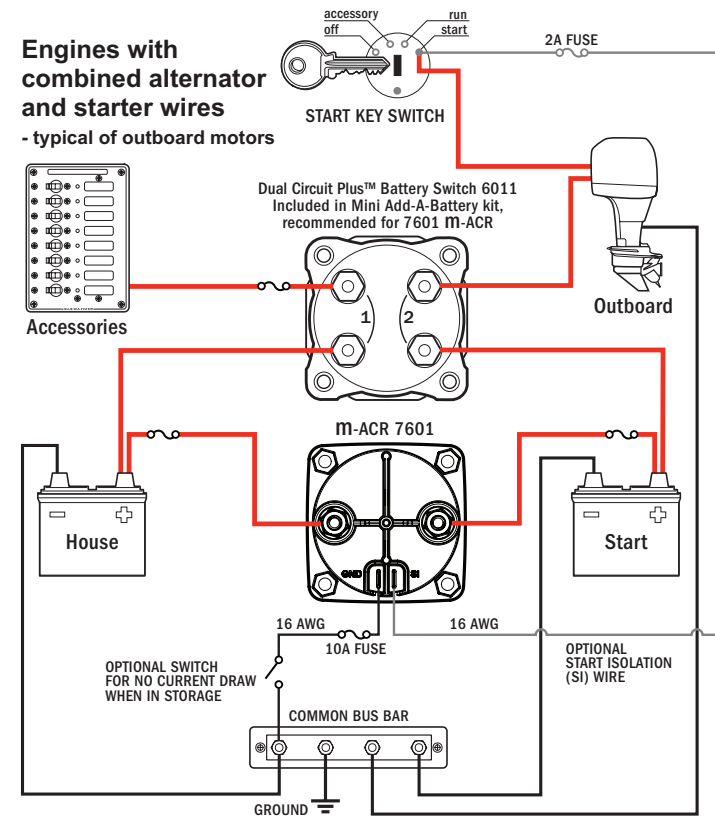

## Dimensioned Drawings

M-ACR, Automatic Charging Relay 7601

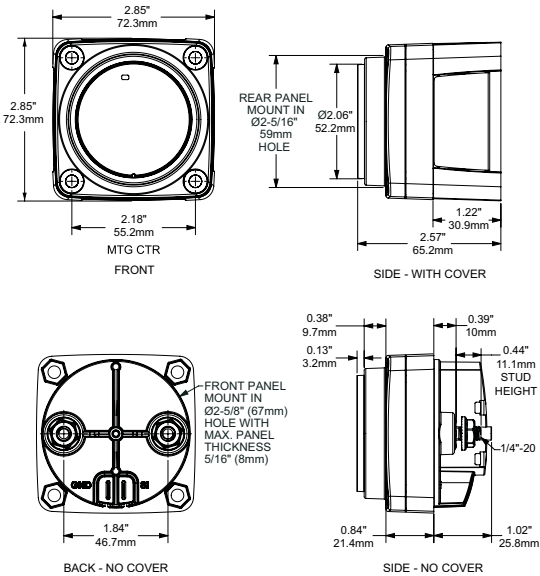

m-Series, Dual Circuit Plus™ Battery Switch 6011  
(Included with 7649 Mini Add-A-Battery)

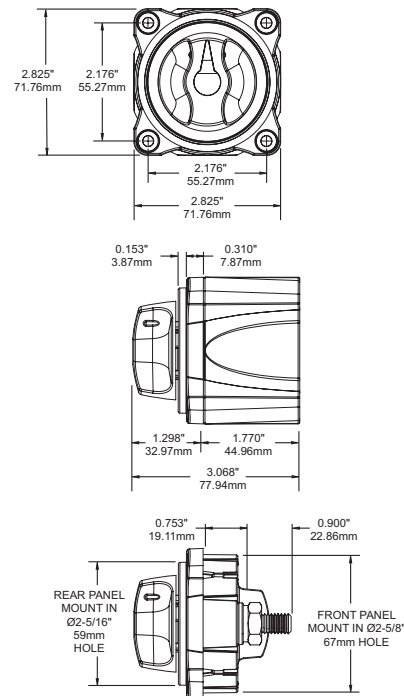

**See Wire Size and Fuse Rating chart for connections from ACR positive terminals.**  
Note: To determine wire sizes and fuse ratings for all other wires illustrated, please visit the Circuit Wizard at [circuitwizard.bluesea.com](http://circuitwizard.bluesea.com)

- These installation diagrams show typical applications only. Your application may differ. For further information, please go to [www.bluesea.com](http://www.bluesea.com) and navigate to Resources/Application Briefs and Technical Briefs.
- Because the M-ACR is dual sensing, the battery connection terminals are interchangeable. M-ACR function will not be affected by reversal of the starting and house batteries versus the diagram.
- If the status indicator LED is triple-flashing, the M-ACR is in a lockout state, and will not combine batteries until the lockout condition is removed. Ensure neither battery is below 10V for a 12V system or 20V for a 24V system.
- If the status indicator LED is double-flashing, check for positive voltage on the start isolation terminal.
- It is recommended that the M-ACR be connected directly to your battery positive terminals through appropriately sized fuses. Connecting in a different location such as a battery switch may affect accuracy because of voltage drop along current carrying conductors.
- If you are not knowledgeable about marine electrical systems, please consult an electrical professional for help with installation.
- If your electrical system is configured with a charging source that cannot supply the full load current being drawn from the batteries, open/close cycling can occur. If this cycling continues, the second battery bank could eventually discharge even though a charge source is present.

### Guarantee

Blue Sea Systems stands behind its products for as long as you own them. Find detailed information at [www.bluesea.com/about](http://www.bluesea.com/about). For customer service, call 800-222-7617.



425 Sequoia Drive  
Bellingham, WA 98226 USA  
p 360.738.8230  
p 800.222.7617 USA and Canada  
f 360.734.4195  
conductor@bluesea.com  
[www.bluesea.com](http://www.bluesea.com)

## Free Manuals Download Website

<http://myh66.com>

<http://usermanuals.us>

<http://www.somanuals.com>

<http://www.4manuals.cc>

<http://www.manual-lib.com>

<http://www.404manual.com>

<http://www.luxmanual.com>

<http://aubethermostatmanual.com>

Golf course search by state

<http://golfingnear.com>

Email search by domain

<http://emailbydomain.com>

Auto manuals search

<http://auto.somanuals.com>

TV manuals search

<http://tv.somanuals.com>