



16/24 Ports Gigabit Ethernet Rack Switch

A02-G16

A02-G24



MULTILINGUAGE Quick Start Guide A02-G16(24)[V1.1]_GX01

Where solutions begin

ISO 9001:2000 Certified Company

Download from www.Somanuals.com. All Manuals Search And Download.



ITALIANO

Questo prodotto è coperto da garanzia Atlantis Land **Fast-Swap** della durata di 3 anni. Per maggiori dettagli in merito o per accedere alla documentazione completa in Italiano fare riferimento al sito www.atlantis-land.com.

ENGLISH

This product is covered by Atlantis Land 3 years **Fast-Swap** warranty. For more detailed informations please refer to the web site www.atlantis-land.com. For more detailed instructions on configuring and using this device, please refer to the online manual.

FRANCAIS

Ce produit est couvert par une garantie Atlantis Land **Fast-Swap** de 3 ans. Pour des informations plus détaillées, référez-vous svp au site Web www.atlantis-land.com.

DEUTSCH

Dieses Produkt ist durch die Atlantis Land 3 Jahre **Fast-Swap** Garantie gedeckt. Für weitere Informationen, beziehen Sie sich bitte auf Web Site www.atlantis-land.com.

ESPAÑOL

Este producto esta cubierto por Atlantis Land con una garantía **Fast-Swap** de 3 años. Para mayor información diríjase a nuestro sitio Web www.atlantis-land.com.



The award of the information is facultative, but its lack will prevent ATLANTIS LAND® from starting the Guarantee process requested.



Register your product!

www.atlantis-land.com

Registration on the web site **www.atlantis-land.com** within 15 days from the purchase of the product dismiss the customer from showing a valid proof of purchase (Sale Receipt or Invoice) in case of the request of intervention. For further information we invite you to look at our web site at the section WARRANTY.

Copyright

The Atlantis Land logo is a registered trademark of Atlantis Land S.p.A. All other names mentioned may be trademarks or registered trademarks of their respective owners. Subject to change without notice. No liability for technical errors and/or omissions.



INDEX

ITALIANO

1	Panoramica Generale	9
1.1	Tecnologia Gigabit Ethernet	9
1.2	Tecnologia Fast Ethernet.....	9
1.3	Tecnologia Switching.....	10
2	Caratteristiche.....	10
3	Installazione.....	11
3.1	Contenuto della Confezione.....	11
3.2	Installazione Desktop.....	11
3.3	Installazione Rack.....	12
3.4	Accensione e messa in opera	13
3.5	Pannello Frontale.....	13
3.6	Pannello Posteriore	14
4	Supporto Offerto	14

ENGLISH

1	Introduction.....	17
1.1	Gigabit Ethernet.....	17
1.2	Switching Technology.....	17
2	Features	18
3	Unpacking and Setup.....	19
3.1	Package Contents	19
3.2	Mounting the Switch on a Desk.....	19
3.3	Mounting the Switch in a rack	21
3.4	Power On.....	22
3.5	Front Panel.....	22
3.6	Rear Panel.....	23
4	Product Support.....	23

FRANCAIS

1	Introduction.....	27
1.1	GigaBit Ethernet	27
1.2	Fast Ethernet	27
1.3	Switching Technology.....	27
2	Principales caractéristiques	28
3	Installation	28
3.1	Contenu de l'emballage	29



3.2 Installation Desktop	29
3.3 Rack Mounting.....	30
3.4 AC Power	31
3.5 Panneau Avant(Voyants)	31
3.7 Panneau Arrière.....	32
4 Support.....	32
ESPAÑOL	
1 Introducción	35
1.1 Tecnología Gigabit Ethernet	35
1.2 Tecnología Fast Ethernet.....	35
1.3 Tecnología de Conmutación (Switching).....	36
2 Características.....	36
3 Instalación	36
3.1 Contenido de la Caja	37
3.2 Instalación tipo desktop	37
3.3 Rack Montaje.....	38
3.4 AC Power	38
3.5 Panel Frontal	39
3.7 Panel Posterior	40
4 Soporte Técnico.....	40
APPENDIX A: Technical Specifications	41

AVVERTENZE

Abbiamo fatto di tutto al fine di evitare che nel testo, nelle immagini e nelle tabelle presenti in questo manuale, nel software e nell'hardware fossero presenti degli errori. Tuttavia, non possiamo garantire che non siano presenti errori e/o omissioni. Infine, non possiamo essere ritenuti responsabili per qualsiasi perdita, danno o incomprensione compiuti direttamente o indirettamente, come risulta dall'utilizzo del manuale, software e/o hardware.

Il contenuto di questo manuale è fornito esclusivamente per uso informale, è soggetto a cambiamenti senza preavviso (a tal fine si invita a consultare il sito www.atlantisland.it o www.atlantis-land.com per reperire gli aggiornamenti) e non deve essere interpretato come un impegno da parte di Atlantis Land spa che non si assume responsabilità per qualsiasi errore o inesattezza che possa apparire in questo manuale. Nessuna parte di questa pubblicazione può essere riprodotta o trasmessa in altra forma o con qualsiasi mezzo, elettronicamente o meccanicamente, comprese fotocopie, riproduzioni, o registrazioni in un sistema di salvataggio, oppure tradotti in altra lingua e in altra forma senza un espresso permesso scritto da parte di Atlantis Land spa. Tutti i nomi di produttori e dei prodotti e qualsiasi marchio, registrato o meno, menzionati in questo manuale sono usati al solo scopo identificativo e rimangono proprietà esclusiva dei loro rispettivi proprietari.

Restrizioni di responsabilità CE/EMC

Il prodotto descritto in questa guida è stato progettato, prodotto e approvato in conformità alle regole EMC ed è stato certificato per non avere limitazioni EMC.

Se il prodotto fosse utilizzato con un PC non certificato, il produttore non garantisce il rispetto dei limiti EMC. Il prodotto descritto è stato costruito, prodotto e certificato in modo che i valori misurati rientrino nelle limitazioni EMC. In pratica, ed in particolari circostanze, potrebbe essere possibile che detti limiti possano essere superati se utilizzato con apparecchiature non prodotte nel rispetto della certificazione EMC. Può anche essere possibile, in alcuni casi, che i picchi di valore siano al di fuori delle tolleranze. In questo caso l'utilizzatore è responsabile della "compliance" con i limiti EMC. Il Produttore non è da ritenersi responsabile nel caso il prodotto sia utilizzato al di fuori delle limitazioni EMC.

CE Mark Warning

Questo dispositivo appartiene alla classe B. In un ambiente domestico il dispositivo può causare interferenze radio, in questo caso è opportuno prendere le adeguate contromisure.



Dichiarazione di Conformità CE

Questo dispositivo è stato testato ed è risultato conforme alle direttive EMC 89/336/EEC, Direttive a basso voltaggio 73/23/EEC. Questo dispositivo inoltre soddisfa i seguenti standards:

- EN55022
- EN55024
- EN60950



La ringraziamo per aver scelto un apparato Atlantis Land, con NetMaster G16/24 è possibile creare una rete LAN in tecnologia Gigabit capace di soddisfare le più spinte richieste di velocità.

1 Panoramica Generale

Questo breve capoverso descrive le caratteristiche proprie dello Switch e fornisce alcune informazioni di carattere generale sulla tecnologia di switch Fast/Giga Ethernet.

1.1 Tecnologia Gigabit Ethernet

Gigabit è un'estensione della IEEE 802.3 Ethernet che utilizza la stessa struttura dei pacchetti, formato, il protocollo CSMA/CD, full duplex, controllo di flusso ma consente un incremento teorico notevole del throughput. Anche questa tecnologia è retrocompatibile con le tecnologie Ethernet e Fast Ethernet. L'incremento di velocità offerto dalla tecnologia Gigabit Ethernet è essenziale in alcune applicazioni e consente finalmente di eliminare quei fastidiosi colli di bottiglia che rallentano l'intera LAN. La creazione di una dorsale (backbone) ad 1Gbps può avere un enorme impatto sui tempi di risposta della rete ed aumentare significativamente la velocità di comunicazione tra diverse subnet.

E' finalmente possibile sfruttare in maniera propria applicazioni particolari come quelle di videoconferenza, complesse elaborazioni su file video o immagini etc. Un ulteriore vantaggio della tecnologia Gigabit Ethernet risiede nel riutilizzo dei cablaggi esistenti. E' infatti possibile usare il cablaggio precedentemente utilizzato per la Fast Ethernet (4-pair UTP/STP cat 5) con la nuova tecnologia.

1.2 Tecnologia Fast Ethernet

Il continuo aumento di importanza della LAN e l'incremento della complessità delle applicazioni che girano sui normali PC ha portato alla necessità di avere strutture che fornissero delle performance sempre crescenti. Un notevole numero di tecnologie diverse per LAN ad alta velocità ha visto la luce proprio per rispondere a queste esigenze. La soluzione che si è imposta (la 100BASE-T) risponde a queste rinnovate esigenze pur avendo un approccio non distruttivo con l'installato.

Nelle specifiche IEEE 802.3 LAN sono contenute tutte le caratteristiche del 100Mbps Fast Ethernet. Questa è un'estensione del precedente standard a 10Mbps cui aggiunge la capacità di trasmissione dieci volte maggiore, pur mantenendo il protocollo CSMA/CD. Questo consente agli apparati conformi alla Fast Ethernet di essere



utilizzati anche in modalità Ethernet, consentendo un riutilizzo di apparati e una migrazione graduale alla nuova tecnologia.

1.3 Tecnologia Switching

Lo switching è una strada che rende possibile da un lato l'aumento della capacità (numero di utenti collegati) di una rete e dall'altra la diminuzione del carico suddividendo la LAN in diversi segmenti. Solo i segmenti opportuni sono interessati al contrario dell'hub che replica il traffico su tutti i segmenti.

Lo switch attua una sorta di bridge selettivo tra segmenti individuali. Lo switch infatti, senza interferire con altri segmenti, automaticamente instrada il traffico da un segmento ad un altro. In questa maniera la capacità della LAN cresce notevolmente, pur non dovendone cambiare l'hardware presente.

La tecnologia Switching LAN è un deciso miglioramento rispetto alla precedente generazione dei network bridges caratterizzati da un'alta latenza. Questo problema può essere risolto anche facendo uso di Router che segmentano la LAN ma il costo di questa tecnologia notevolmente superiore unito alla necessità di un continuo controllo rende questo approccio quasi impraticabile. Oggi lo switch rappresenta la soluzione ideale per risolvere i problemi di congestione nella maggior parte delle LAN.

2 Caratteristiche

Lo Switch 16/24 10/100/1000 Mbps Gigabit Ethernet è stato disegnato per essere facilmente installato ed offrire alte performance in un ambiente dove il traffico della rete ed il numero di utenti sono in continuo aumento. Di seguito vengono riportate le principali caratteristiche.

- Compliant with IEEE802.3 , IEEE802.3u, IEEE802.3ab standards
- 16/24 ports 10/100/1000Mbps Auto-Sense RJ45 supporting Auto-MDI/MDIX
- All ports Support Full/Half Duplex transfer mode for 10/100Mbps and Full Duplex transfer mode for 1000Mbps
- Supports IEEE802. x flow control for full-duplex mode and backpressure for half-duplex transfer mode
- Non-blocking switching architecture that forwards and filters packets at full wire-speed for maximum throughput
- Supports MAC address auto-learning and auto-aging
- LED indicators for monitoring power, fan, link, speed and activity
- Rack-mountable steel case

- Internal power supply

3 Installazione

Questo capitolo fornisce informazioni per l'installazione e la configurazione dello Switch. Per evitare possibili cause di danneggiamento è opportuno leggere attentamente l'intero paragrafo prima di partire.

3.1 Contenuto della Confezione

Una volta aperta la confezione in cartone dovrebbero essere presenti:

- NetMaster G16/24
- Cavo di alimentazione
- Supporti in gomma per il montaggio desktop
- Kit di installazione per strutture rack 19"
- Guida Utente (Italiano, Inglese, Francese e Spagnolo)
- CDRom con Manualistica

Qualora mancasse uno qualsiasi di questi componenti è opportuno rivolgersi immediatamente al rivenditore.

3.2 Installazione Desktop

Prima di posizionare lo switch sulla scrivania, attaccare i supporti in gomma forniti per il montaggio desktop alle scanalature poste nella parte inferiore del prodotto, quindi posizionare NetMaster G16/24 sulla superficie della stessa.



- Installare lo Switch in un luogo abbastanza fresco ed asciutto. A tal proposito consultare le specifiche ambientali (riportate in fondo a questo manuale).
- Installare lo Switch in un luogo privo di vibrazioni meccaniche, campi elettromagnetici e non esposto alla luce solare diretta.
- Lasciare almeno 10 cm di spazio tra lo Switch ed altre superfici.
- Assicurarsi di disporre di una fonte di alimentazione distante non più di 1,5 m dall'apparato.

3.3 Installazione Rack

NetMaster G16/24 è disegnato in accordo allo standard di montaggio rack 19" di Electronic Industries Association.

Spegnere tutti gli apparati collegati allo switch prima del montaggio in una struttura rack, quindi avvitare i 2 supporti "L" agli alloggiamenti posti sui 2 lati del prodotto tramite le viti fornite a corredo (vedi figura).

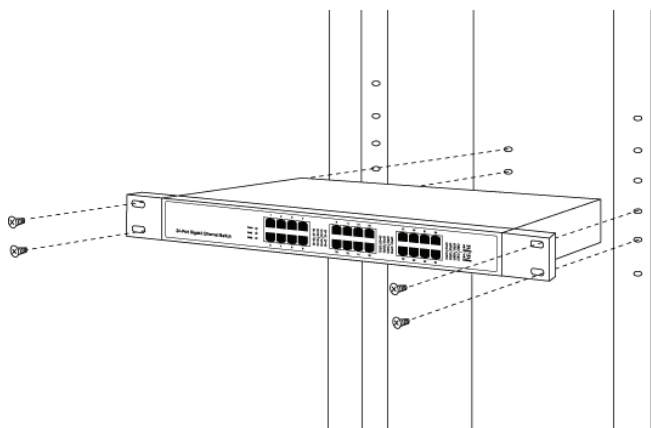
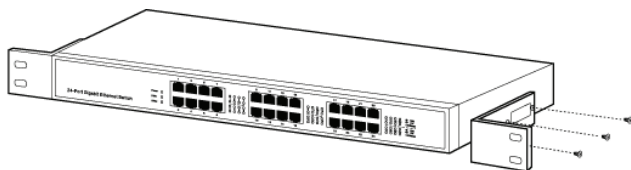

3.4 Accensione e messa in opera

Il Gigabit Ethernet Switch è alimentato in AC direttamente tramite il cavo di alimentazione fornito a corredo.

Collegando il prodotto alla rete elettrica, lo stesso si inizierà automaticamente e i LED di diagnostica si accenderanno tramite la sequenza sottodescritta:

- Tutti i LED Link/Act e 1000 Mbps lampeggeranno simultaneamente per un secondo. Questo comportamento indica un reset dell'apparato.
- Il LED Power si accenderà in modalità fissa.
- I LED FAN1 e FAN2 si accenderanno in modalità fissa.



Nel caso in cui il comportamento dei LED fosse differente da quello sovradescritto, si consiglia di controllare il corretto collegamento del prodotto alla rete di alimentazione.

3.5 Pannello Frontale

Nel pannello frontale dell'apparato sono presenti i LED che consentono una diagnostica immediata sullo stato di funzionamento dello Switch e dei vari link.

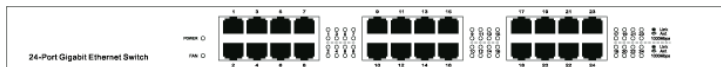

LED	SIGNIFICATO
Power	Acceso Rosso fisso per indicare la corretta alimentazione dell'apparato.
FAN (1-2)	Accesso verde fisso per indicare che la fonte di raffreddamento corrispondente funziona correttamente.
Link/ACT	Lampeggiante durante la trasmissione/ricezione dati. Accesso verde fisso quando la porta corrispondente è connessa ad un dispositivo.

1000Mbps

Lampeggiante durante la trasmissione/ricezione dati.
Accesso verde fisso per indicare un link Gigabit Ethernet.

NOTE!

Se il led Power resta spento verificare che:

- La rete elettrica sia funzionante
- Verificare che il cavo di alimentazione sia collegato adeguatamente tanto allo switch che alla presa elettrica

Se il led Link/Act resta spento verificare che:

- Il cavo sia saldamente collegato alla porta dello Switch (e/o altro dispositivo).
- Il dispositivo collegato allo switch sia acceso (e/o la scheda di rete funzionante).
- Il cavo Ethernet sia lungo non più di 100m.

NOTE!

La seconda ventola di raffreddamento è presente solo sul modello NetMaster G24.

3.6 Pannello Posteriore

Il pannello posteriore del NetMaster G16/24 è composto dalla sola presa di alimentazione AC.

Collegare il connettore femmina del cavo di alimentazione alla stessa e l'altro capo alla presa elettrica.



4 Supporto Offerto

Per qualunque altro problema o dubbio è possibile contattare l'help desk telefonico (02/93907634) gratuito di Atlantis Land che fornirà assistenza da lunedì al giovedì dalle 9:00 alle 13:00 e dalle 14:00 alle 18:00 ed il venerdì dalle 9:00 alle 13:00. E' possibile anche utilizzare il fax (02/93906161) la posta elettronica ([info@atlantis-](mailto:info@atlantis-land.com)



land.com oppure tecnici@atlantis-land.com) per esporre eventuali domande o problemi.

Atlantis Land SpA
Viale De Gasperi 122
20017 Mazzo di Rho (MI)

Tel: +39.(0)2.93906085 (Fax: +39.(0)2.93906161)

Help Desk :+39.(0)2.93907634

**Copyright Statement**

No part of this publication may be reproduced, stored in a retrieval system, or transmitted in any form or by any means, whether electronic, mechanical, photocopying, recording or otherwise without the prior writing of the publisher. Windows™ 98SE/2000/ME/XP are trademarks of Microsoft® Corp. Pentium is trademark of Intel. All copyright reserved.

The Atlantis Land logo is a registered trademark of Atlantis Land SpA. All other names mentioned may be trademarks or registered trademarks of their respective owners. Subject to change without notice. No liability for technical errors and/or omissions.

CE Mark Warning

This is a Class B product. In a domestic environment, this product may cause radio interference, in which case the user may be required to take adequate measures.

CE/EMC Restriction of Liability

The product described in this handbook was designed, produced and approved according to the EMC-regulations and is certified to be within EMC limitations.

If the product is used in an uncertified PC, the manufacturer undertakes no warranty in respect to the EMC limits. The described product in this handbook was constructed, produced and certified so that the measured values are within EMC limitations. In practice and under special circumstances, it may be possible, that the product may be outside of the given limits if it is used in a PC that is not produced under EMC certification. It is also possible in certain cases and under special circumstances, which the given EMC peak values will become out of tolerance. In these cases, the user himself is responsible for compliance with the EMC limits.

Declaration of Conformity

In compliance with the EMC Directive 89/336/EEC, Low Voltage Directive 73/23/EEC, this product meets the requirements of the following standards:

- EN55022
- EN55024
- EN60950



Thank you for purchasing the NetMaster G16/24 that provides the easiest way to Gigabit networking. For more detailed instructions on configuring and using this device, please refer to the online manual.

1 Introduction

This section describes the features of the 16/24 Port 1000BASE-T Gigabit Ethernet Switch, as well as providing some background information about Gigabit Ethernet and switching technology.

1.1 Gigabit Ethernet

Gigabit Ethernet is an extension of IEEE 802.3 Ethernet utilizing the same packet structure, format, and support for CSMA/CD protocol, full duplex, flow control, and management objects, but with a tenfold increase in theoretical throughput over 100-Mbps Fast Ethernet and a hundredfold increase over 10-Mbps Ethernet. Since it is compatible with all 10-Mbps and 100-Mbps Ethernet environments, Gigabit Ethernet provides a straightforward upgrade without wasting a company's existing investment in hardware, software, and trained personnel.

The increased speed and extra bandwidth offered by Gigabit Ethernet is essential to coping with the network bottlenecks that frequently develop as computers and their busses get faster and more users use applications that generate more traffic. Upgrading key components, such as your backbone and servers to Gigabit Ethernet can greatly improve network response times as well as significantly speed up the traffic between your subnets.

Gigabit Ethernet supports video conferencing, complex imaging, and similar data-intensive applications. Likewise, since data transfers occur 10 times faster than Fast Ethernet, servers outfitted with Gigabit Ethernet NIC's are able to perform 10 times the number of operations in the same amount of time.

1.2 Switching Technology

Another key development pushing the limits of Ethernet technology is in the field of switching technology. A switch bridges Ethernet packets at the MAC address level of the Ethernet protocol transmitting among connected Ethernet or fast Ethernet LAN segments.

Switching is a cost-effective way of increasing the total network capacity available to users on a local area network. A switch increases capacity and decreases network loading by making it possible for a local area network to be divided into different



segments which don't compete with each other for network transmission capacity, giving a decreased load on each.

The switch acts as a high-speed selective bridge between the individual segments. Traffic that needs to go from one segment to another is automatically forwarded by the switch, without interfering with any other segments. This allows the total network capacity to be multiplied, while still maintaining the same network cabling and adapter cards.

Switching LAN technology is a marked improvement over the previous generation of network bridges, which were characterized by higher latencies. Routers have also been used to segment local area networks, but the cost of a router and the setup and maintenance required make routers relatively impractical. Today's switches are an ideal solution to most kinds of local area network congestion problems.

2 Features

The NetMaster G16/24 16/24-port Gigabit Ethernet Switch provides you with a high-performance, low-cost, easy-to-use, seamless and standard upgrade to boost your old network to 1000Mbps. Increase the speed of your network server and backbone connections make Gigabit a reality. Power users in the home, office, workgroup, or creative production environment can now move large, bandwidthintensive files faster. Transfer graphics, CGI, CAD, or multimedia files and other applications that have to move large files across the network almost instantly.

The NetMaster G16/24 features a non-blocking switching architecture that forwards and filters packets at full wire-speed for maximum throughput.

MAC address auto-learning and auto-aging, IEEE802.3 x flow control for full-duplex mode and backpressure for half-duplex mode. It is compatible with all 10,100, and 1000Mbps Ethernet devices because it is standard-based, it protects your existing network investments while providing you with a straightforward migration path to faster Gigabit speeds.

The NetMaster G16/24 is plug-and-play and no configuration is required. Auto MDI/MDI-X cable detection on all ports eliminate the need for crossover cable or Uplink port. Each port can be used as general ports or Uplink ports, and any port can be simply plugged into a server, a hub, a router or a switch, using the straight cable or crossover cable. Diagnostic LEDs which display link status and activity, allowing you to quickly detect and correct problems on the network.



NetMaster G16/24 Main Features:

- Compliant with IEEE802.3 , IEEE802.3u, IEEE802.3ab standards
- 16/24 10/100/1000Mbps Auto-Sense RJ45 ports supporting Auto-MDI/MDIX
- All ports Support Full/Half Duplex transfer mode for 10/100Mbps and Full Duplex transfer mode for 1000Mbps
- Supports IEEE802. x flow control for full-duplex mode and backpressure for half-duplex transfer mode
- Non-blocking switching architecture that forwards and filters packets at full wire-speed for maximum throughput
- LED indicators for monitoring power, fan, link, speed and activity
- Rack-mountable steel case
- Internal power supply

3 Unpacking and Setup

This chapter provides unpacking and setup information for the Switch.

3.1 Package Contents

Unpack the package and check all the items carefully. If any item contained is damaged or missing, please contact your local dealer as soon as possible. Also, keep the box and packing materials in case you need to ship the unit in the future. The package should contain the following items:

- One NetMaster G16/24 Switch
- One power cord
- Rubber footpads for Desk-mount
- Rack-mount kit for installing the switch in a 19-inch rack
- One Quick Start Guide (English, Italian, French and Spanish)
- One CD with user's manual

3.2 Mounting the Switch on a Desk

Before place the Switch on a desk, attach four rubber footpads to the flutes on the Switch bottom, then lay the Switch on the desktop, where can be have as much as 5 kg placed on top.



NOTE!



- Make sure there is a grounded AC outlet within 1.5 meters, and working well.
- Make sure there is free space for radiating heat and air.
- Make sure not to place anything too heavy on top of the switch.

3.3 Mounting the Switch in a rack

The dimension of NetMaster G16/24 is designed according to the standard 19" rack-mountable steel case of Electronic Industries Association.

Turn off all the equipment connected to the Switch before mounting it in the rack, then rivet the two "L" brackets onto each side of the Switch, fasten it with screws in the rack.

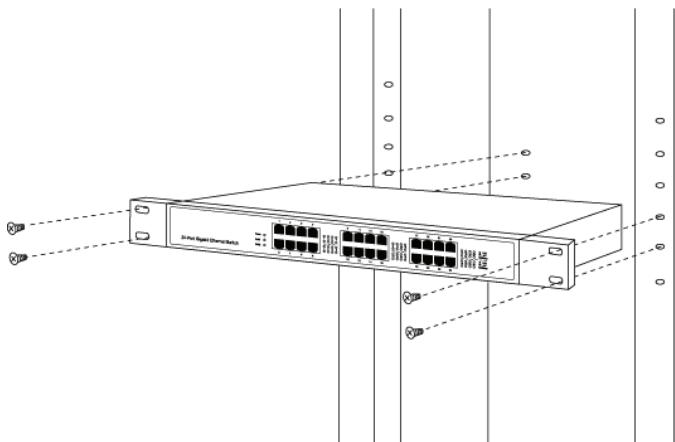
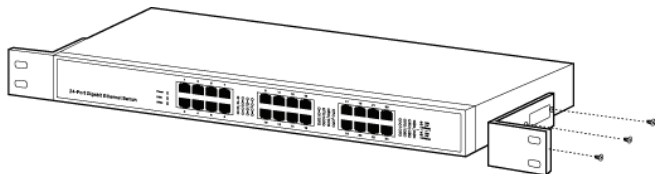

3.4 Power On

NetMaster G16/24 Gigabit Ethernet Switch is powered by AC power supply. Powering on the Switch, it will automatically initialize and its LED indicators should respond as follows:

1. All of the Link/Act and 1000Mbps LED indicators will flash momentarily for one
2. second, which represent a resetting of the system.
3. The Power indicator will light up.
4. The FAN LED indicators will light up.

If the LED indicators don't respond as described above, please check the power supply and connection.

3.5 Front Panel

The front panel of the NetMaster G16/24 consists of switch LED indicators, 16/24 10/100/1000Mbps RJ-45 ports.

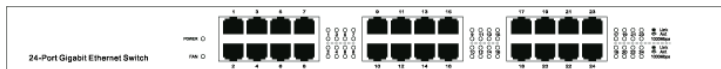

LED	MEANING
Power	This indicator will light solid red when the Switch powers up. If the LED is not lit, please check the power supply and connection.
FAN (1-2)	This indicator will light solid green when the corresponding cooling fan works properly. NetMaster G24 has two FAN LEDs. FAN1 indicates the fan at the right-hand side and FAN2 indicates the fan on the rear panel. NetMaster G16 has one FAN LED.
Link/ACT	This indicator will light solid green when the corresponding port is connected to another device and will flash green when data is being transmitted or received on the working connection.

1000 Mbps

This indicator will light solid green when the corresponding port is connected to a 1000Mbps device.



The Power LED is not lit

- Make sure the AC power Adapter is plugged into an outlet properly and it's connector is plugged into the power jack of the switch.
- Make sure the power source is ON.
- Make sure you are using the included power adapter supplied with your switch.

The Link/Act LED is not lit when a device is connected to the corresponding port

- Make sure that the cable connectors are firmly plugged into the Switch and the device.
- Make sure the connected device is turned on and its adapter is installed correctly and is working.
- The cable must be less than 100 meters long.

3.6 Rear Panel

The rear panel of the NetMaster G16/24 only features a power receptacle, which is an AC power receptacle. Connect the female of the power cord head here, and the male head to the AC power outlet.



4 Product Support

If you have any problems with this device, please consult this manual. If you continue to have problems you should contact the dealer where you bought this device. If you have any other questions you can contact the Atlantis Land company directly at the following address:

Atlantis Land SpA
Viale De Gasperi, 122



20017 Mazzo di Rho(MI)

Tel: +39. 02.93906085, +39. 02.93907634(help desk)

Fax: +39. 02.93906161

Email: info@atlantis-land.com or tecnici@atlantis-land.com

WWW: <http://www.atlantis-land.com>

Copyright

Copyright. 2002 est la propriété de cette société. Tout droits réservés. Sont interdites, la reproduction, la transmission, la transcription, la mémorisation dans un système de sauvegarde où la traduction dans une autre langue ou en langage informatique quels qu'ils soient, de la présente publication, sous quelque forme que ce soit ou quelque en soit le moyen, électronique, mécanique, magnétique, optique, chimique, manuel ou de tout autre genre, sans avoir obtenu préalablement l'autorisation de notre entreprise.

Non-responsabilité

La présente entreprise n'admet ni requêtes ni de garantie, explicites ou implicites, au sujet du contenu et de manière spécifique exclue la possibilité de garantie, communicabilité ou adaptabilité pour des finalités particulières. Le logiciel décrit dans le présent manuel est vendu ou concédé en licence "tel quel". Si les programmes devaient présenter des problèmes après l'achat, l'acquéreur (et non pas la présente entreprise, son distributeur ou concessionnaire) est tenu de prendre en charge tous les coûts de manutention ainsi que les coûts dus à des dommages accidentels ou des conséquences dérivants d'un défaut du logiciel. La présente entreprise se réserve en outre le droit de revoir le contenu de cette publication et d'y apporter des modifications de temps en temps, sans obligation d'informer les utilisateurs de ces changements. Nous avons fait tout notre possible afin d'éviter la présence d'erreurs dans le texte, les images, les tableaux présents dans ce manuel et dans le Cd-Rom. Cependant, nous ne pouvons pas garantir l'absence totale d'erreurs et/ou d'omissions, nous vous remercions donc de nous les signaler et vous prions de nous en excuser. Enfin, nous ne pouvons être tenus pour responsables dans quelque perte que ce soit, dommage ou incompréhension à la suite directe ou indirecte de l'utilisation de notre manuel, le logiciel Cd-Rom et/ou disque dur.

Toutes les marques ou noms de produits mentionnés dans le présent manuel sont des marques commerciales et/ou brevetées par leurs propriétaires respectifs.

Marquage CE

Cet appareil, qui appartient à la Classe B peut causer des interférences radio, dans ce cas nous vous invitons à prendre les contre-mesures appropriées.



Déclaration de Conformité

Cet appareil a été testé et est conforme à la Directive 89/336/EEC, Low Voltage Directive 73/23/ EEC et aux règles :

- EN55022
- EN55024
- EN60950



Félicitations pour avoir choisi ce produit. Ce manuel a été rédigé pour une utilisation avancée du produit.

1 Introduction

Ce chapitre décrit les caractéristiques du Switch et fournit des informations générales sur la technologie de switch Ethernet/Fast Ethernet et Giga Ethernet.

1.1 GigaBit Ethernet

Gigabit Ethernet est une extension de la norme Ethernet IEEE 802.3 qui utilise les mêmes structures de paquets, format, protocole CSMA/CD, full duplex, contrôle de flux tout en permettant une augmentation importante du débit. Cette technologie est compatible avec les technologies Ethernet et Fast Ethernet. L'augmentation de vitesse est essentielle pour certaines applications et permet d'éliminer les ralentissements qui peuvent apparaître sur le réseau LAN. La création d'une dorsale (backbone) à 1Gb/s (2 en full-duplex) peut avoir un impact important sur les temps de réponse et augmenter la vitesse de communication entre divers sous-réseau.

Il est enfin possible d'utiliser des applications gourmandes en bande passante comme la vidéoconférence, des travaux complexes sur fichiers video ou images etc. La compatibilité avec le câblage existant pour le Fast Ethernet (4-pair UTP/STP cat 5) permet de réduire les coûts de mise en œuvre de la nouvelle technologie.

1.2 Fast Ethernet

La norme IEEE 802.3 fixe les caractéristiques du Fast Ethernet 100 Mb/s, il s'agit d'une extension du standard précédent Ethernet 10 Mb/s qui implémente une capacité de transmission dix fois plus importante, tout en maintenant le protocole CSMA/CD. Cela permet aux appareils Fast Ethernet d'être utilisable en mode Ethernet, permettant donc une utilisation des appareils existants et une évolution graduelle vers la nouvelle technologie.

1.3 Switching Technology

Le switching est une solution qui permet d'une part l'augmentation des capacités (nombre d'utilisateurs connectés) d'un réseau et d'autre part la diminution de la charge en divisant le LAN en plusieurs segments. Seuls les segments appropriés sont utilisés au contraire du hub qui répète le trafic sur tous les segments.

Le switch réalise une sorte de pont sélectif entre les segments individuels. Le switch en effet, sans créer d'interférence avec les autres segments, dirige le trafic automatiquement d'un segment à l'autre. La technologie Switching LAN est une

amélioration notable par rapport à la génération précédente de réseaux bridges caractérisés par une plus grande lenteur. Ce problème peut aussi être résolu en utilisant des Routeurs qui segmentent le LAN mais le coût de ces technologies est nettement supérieur et la nécessité d'un contrôle constant rend cette solution quasi-impossible. Aujourd'hui le switch représente la solution idéale pour résoudre les problèmes de congestion dans la plupart des LAN.

2 Principales caractéristiques

Le NetMaster G16/24 a été conçu pour être facilement installé et offrir de hautes performances dans un environnement où le trafic réseau et le nombre d'utilisateurs sont en constante augmentation. Le Switch peut être étendu en le reliant en cascade à travers n'importe quel port (transfert jusqu'à 2000 Mb/s). Grâce à cette caractéristique vous pourrez songer à une extension graduelle de votre Lan en réutilisant au maximum les investissements effectués. Le Switch combine une allocation dynamique de la mémoire et en combinaison avec la technologie de switching store-and-forward assure (en contrôlant le flux de données entre l'émetteur et le receveur) une amélioration des prestations (en diminuant le nombre de paquets perdus).

Voyons à présent, les caractéristiques principales du Switch :

- 16/24 Ports réseaux 10/100/1000 Mbps Giga Ethernet
- Commutation MDI/MDIX pour chaque port
- Modes full et half-duplex pour chaque port
- Mode de transfert: Wire speed reception et transmission
- LEDs individuelles d'activité pour chaque port
- Contrôle de flux (IEEE 802.3x) [full-duplex]
- Contrôle de flux Back pressure [half-duplex]
- Apprentissage Automatique des adresses MAC
- Standard 19" Rack-mount measure

3 Installation

Ce chapitre fournit des informations pour l'installation et la configuration du Switch. Pour éviter les problèmes, nous vous recommandons de lire avec attention ce chapitre avant de commencer.

3.1 Contenu de l'emballage

Une fois ouvert, vous devriez trouver les éléments suivants:

- Switch Giga Ethernet 16/24 ports 10/100/1000 Mbps
- Un câble AC d'alimentation
- Adhésifs à insérer sur la base du Switch
- Accessoire pour le montage sur 19" standard rack
- Guide d'installation rapide (en Français ,Anglais, Espagnol et Italien)
- CDRom avec manuels et logiciels

Si vous constatez qu'un de ces composants manque, merci de vous adresser à votre revendeur.

3.2 Installation Desktop

Dans le cas d'installation du type Desktop utilisez les 4 adhésifs contenus dans la confection (à utiliser dans les appropriés espaces à la base du dispositif). La surface sur la quelle le Switch est posé oit pouvoir soutenir au moins kg. Ne pas mettre objets lourdes au dessus du Switch.

NOTE:



- Ne se trouve pas en plein soleil ni près d'un radiateur ou d'une bouche de chauffage
- N'est pas encombré (vous devez laisser au moins 10 cm dégagés de tous les côtés)
- Doit être bien ventilé (en particulier si vous installez le commutateur dans une armoire)
- Vous avez également besoin d'un câble Ethernet de Catégorie 5 muni de connecteurs RJ-45 pour chacun des périphériques que vous voulez connecter au commutateur.
- La prise électrique doit être en 1.5 metres de l'appareil.

3.3 Rack Mounting

Le Switch peut être monté dans un EIA de dimension standard (19 inch). Accrochez les bras métalliques aux deux côtés du Switch (un chaque côté) et les assurez avec les vis appropriées.

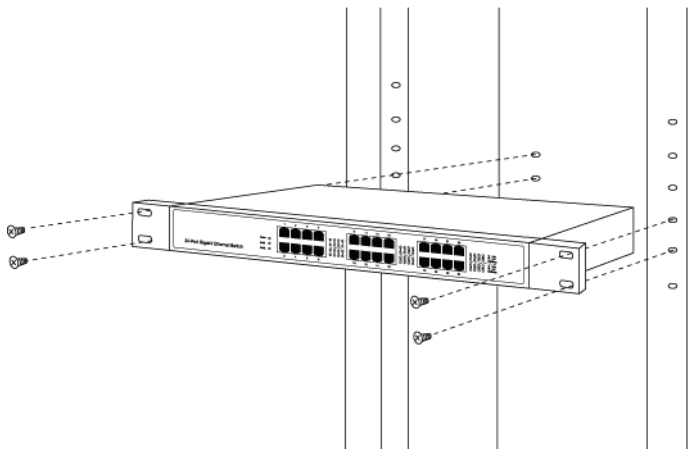
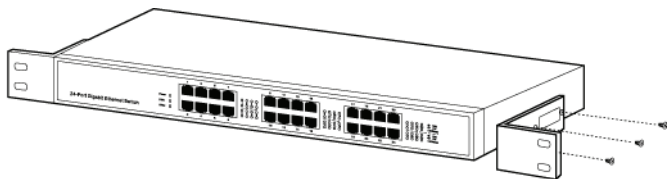

3.4 AC Power

Le Switch doit être connecté à la réseau électrique ayant les suivantes caractéristiques; 100-240V alternée, 50-60Hz. Le câble fourni en dotation se connecte à la prise appropriée sur le panneau postérieur.

Le Switch se réglera automatiquement sur la base du type de réseau électrique et s'allumera.

3.5 Panneau Avant(Voyants)

Les Leds sur le panneau avant du Switch sont: Power, FAN (1-2), Link/Act et 100Mbps.

En consultant les Voyants vous pouvez avoir un diagnostic immédiat du Switch.

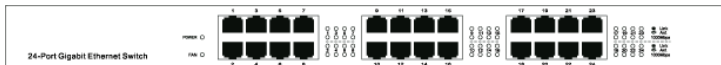

LED	Signification
Power	Indique une alimentation correcte.
FAN (1-2)	Allumée Verte quand le dispositif de refroidissement fonctionne correctement.
Link/ACT	Allumée Verte quand le LAN (réseau) est connecté. Clignote lors des transferts de données.
10/100Mbps	Allumée Verte quand le LAN (réseau) est connecté. Clignote lors des transferts de données.



Aucune LED n'est allumée lorsqu'on connecte le produit réseau électrique, contrôlez la connexion entre l'alimentation et le produit.

3.7 Panneau Arrière



4 Support

Pour tous problèmes ou renseignements, vous pouvez contacter la « help desk » téléphonique gratuite d'Atlantis Land qui vous fournira assistance du: **lundi au jeudi de 9.00 à 13.00 et 14.00 à 18.00. Le vendredi de 9.00 à 13.00.**

Vous pouvez aussi nous contacter par email :

tech-fr@atlantis-land.com

Atlantis Land France

57, Rue d'Amsterdam

75008 Paris

WWW: <http://www.atlantis-land.fr>



AVISO

Hemos hecho todo lo posible para evitar que en el texto, las imágenes, tablas, software y hardware, y la información presentada en general sea carente de errores. A pesar de ello, no podemos garantizar la ausencia de estos.

Atlantis Land no se hacen responsable de daños o pérdidas directas o indirectas, incluidos, pero sin limitación, los daños causados por la imposibilidad su uso, la pérdida de datos o software y/o los daños o pérdidas causados por el uso o funcionamiento incorrecto del equipo y accesorios. En ningún caso, Atlantis Land será responsable de las pérdidas financieras como pérdida de beneficios, daños por inactividad, daños a la reputación, etc.

El contenido de este manual se provee a título informativo y es sujeto a cambios sin previo aviso (invitándose a los clientes a consultar nuestro sitio Web www.atlantis-land.com para mantenerse informados de estos) no haciéndose Atlantis Land responsable de cualquier error o inexactitud que pueda aparecer en esta guía.

Esta publicación no puede ser traducida ni reproducida, ni en todo ni en parte, ni registrada en, o transmitida por, un sistema de recuperación de información, en ninguna forma ni por ningún medio, sea mecánico, fotoquímico, electrónico, magnético, electrónico, por fotocopia, o cualquier otro, sin permiso previo por escrito de Atlantis Land.

Los nombres de los fabricantes, de sus productos, así como de cualquier marca, registradas o no, mencionadas en este manual, son usados a título de referencia, siendo propiedad exclusiva de sus respectivos dueños.

Declaración de conformidad CE/EMC

El producto descrito en esta guía ha sido diseñado, producido y aprobado en conformidad con las reglas EMC, siendo certificado en cumplimiento de la normativa.

Si el producto se usara con un ordenador no certificado, el productor no puede garantizar el respeto a los límites de compatibilidad electromagnética. En la práctica, y en circunstancias particulares, es posible que dichos límites puedan ser superados si se utilizan dispositivos que no respetan la normativa EMC y que, por tanto, no han sido certificados. Asimismo, es posible, que de forma puntual ocurran picos de valor que se encuentran por encima de las tolerancias. En este caso, el usuario es responsable que el dispositivo vuelva a ser conforme con los límites EMC. El fabricante no puede hacerse responsable en el caso de que el producto sea utilizado fuera de los límites dictados por la normativa EMC.

**Aviso sobre el distintivo CE**

Este es un producto de Clase B. En un entorno doméstico este producto puede provocar interferencias de radio por lo que, si fuera así, es necesario que el usuario tome las medidas adecuadas

Declaración de Conformidad

Este dispositivo ha sido probado, determinándose conforme con la directiva 89/336/EEC y Low Voltage Directive 73/23/ EEC. Después de su valoración, se ha establecido que el dispositivo se ajusta a los siguientes estándares:

- EN55022
- EN55024
- EN60950



Gracias por comprar el conmutador 16/24 puertos 1000BASE-T Gigabit Ethernet el cual proporciona la forma más fácil de conectarse a una red Giga Ethernet. Este documento es la guía rápida. Para una información más detallada consulte el manual incluido en el CDRom.

1 Introducción

En este breve resumen le damos una breve introducción a las características técnicas del conmutador (switch) así como información de carácter general sobre la tecnología de conmutación Fast/ Giga Ethernet.

1.1 Tecnología Gigabit Ethernet

Gigabit es una extensión del estándar IEEE 802.3 Ethernet, utilizando la misma estructura del paquete, formato, manteniendo el protocolo CSMA/CD, siendo este full dúplex e incrementado, gracias a multiplicar por diez la velocidad del medio, la capacidad de transmisión. El estándar ha sido concebido para ser retro-compatible tanto con la tecnología Ethernet como Fast Ethernet. Este incremento de velocidad, permite eliminar los cuellos de botella que se encuentran en muchas LAN, permitiendo el uso de aplicaciones intensivas en tráfico, así como la creación de redes dorsales (backbone) a 1Gbps a modo de reducir los tiempos de repuesta e incrementar las tasas de transferencia entre subredes.

Otra ventaja adicional es la posibilidad de utilizar la infraestructura existente para Fast Ethernet, con cables UTP/STP CAT 5, si tener que, por ello, hacer una inversión importante para la mejora que nos proporciona la tecnología Gigabit Ethernet.

1.2 Tecnología Fast Ethernet

El continuo aumento de la comunicación entre ordenadores y la creciente necesidad de la transmisión de datos de las aplicaciones que corren sobre estos, ha hecho necesario que las redes que comunicaban los mismos incrementaran su capacidad. Como solución a esta necesidad, surgió el estándar IEEE802.3, sobre el que se basa la tecnología 100BASE-T, la que posteriormente se impuso a finales de los años 90 como el estándar. Las especificaciones del IEEE802.3x en sus diferentes versiones, son la base sobre la que se construyen tanto el estándar tanto Ethernet, como sus sucesores, FastEthernet y GigaEthernet. Todos ellos comparten el protocolo CSMA/CD, manteniendo de esta forma la retro-compatibilidad de los desarrollos posteriores.

1.3 Tecnología de Conmutación (Switching)

La conmutación de paquetes permite que, de una parte se aumente de forma significativa el número de usuarios de la red – si la comparamos con los concentradores (hubs) –, y que, por otra parte, disminuya la carga de la red al subdividir la LAN en varios sub-segmentos. Los concentradores, tan extendidos anteriormente, cargaban enormemente la red al transmitir de forma indiscriminada los paquetes a toda la red, creando grandes latencias. Sin embargo, los conmutadores emulan a modo de centralita la comunicación entre las tarjetas de red, creando enlaces virtuales entre dos puntos y minimizando el tráfico de la LAN.

2 Características

El conmutador de 16/24 puertos 10/100/1000 Mbps Gigabit Ethernet, ha sido diseñado para ser de fácil instalación y ofrecer altas prestaciones, sobre todo para aquellos entornos donde el tráfico o el número de usuarios aumenta constantemente.

- 16/24 puertos 1000BASE-T Gigabit Ethernet
- Soporta Auto-negociación para 10/100/1000 Mbps y modalidad duplex
- Soporta Auto-MDIX para cada puerto
- Soporta transmisión Full/Half-Duplex a 10/100 Mbps
- Soporta transmisión Full-Duplex a 1000 Mbps
- Transmisión y recepción a capacidad máxima en todos los puertos
- Frontal con numerosas LEDs de diagnóstico
- Control de flujo Full-Duplex IEEE 802.3x
- Control de flujo “Back Pressure” en modalidad Half-Duplex
- Standard 19” Rack-mount size

3 Instalación

A continuación le facilitamos las instrucciones de cómo instalar y configurar su conmutador. Por favor, le recomendamos que lea con detalle las instrucciones con el fin de no dañar el dispositivo.

3.1 Contenido de la Caja

Dentro de la caja debería encontrar los siguientes productos:

- Conmutador Gigabit Ethernet A02-G16/24
- Un cable AC de alimentación
- Adhesivos de inserir sobre la base de lo Switch
- Accesorios para el montaje sobre 19" standard rack
- Guía rápida
- Manual multilingüe (CD-ROM)

En el caso de que faltase alguno de ellos, por favor, póngase en contacto con el punto de venta donde ha comprado el producto.

3.2 Instalación tipo desktop

En caso de instalación tipo Desktop utilizar los 4 adhesivos contenidos en la confección (tengon que ser inseridos en los espacios aptos en la base del dispositivo). La superficie sobre la que se apoja el Switch debe poder sustiner por lo menos 5 kg. No pone objetos pesados sobre el Switch.



- Instalar el conmutador en un lugar fresco y seco. Consulte las especificaciones ambientales al final de este manual.
- Instalar el conmutador en un lugar exento de vibraciones mecánicas, campos electromagnéticos y que no tenga exposición directa a la luz solar.
- Dejar al menos 10cm de espacio entre el dispositivo y otras superficies.
- Asegurarse de conectar de forma correcta el conector del alimentador al enchufe posterior del aparato.

3.3 Rack Montaje

El Switch puede ser montado en un EIA de dimensión standard (19 inch). Junte los brazos metálicos a ambos los lados del Switch (uno para cada lado) e asegurelos con los aptos tornillos.

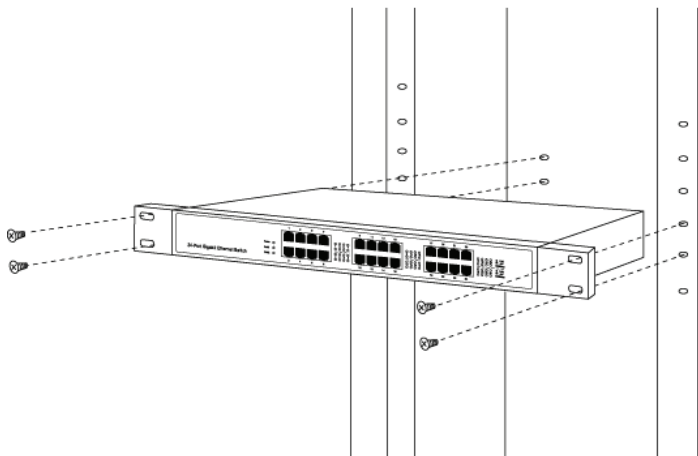
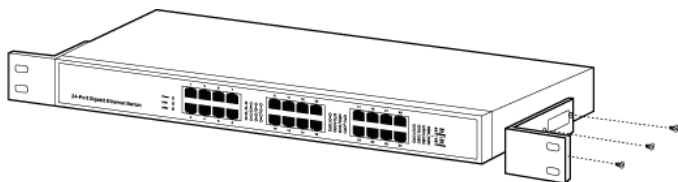

3.4 AC Power

El Switch debe ser junto a la red eléctrica con las siguientes características : 100-240V Alternada, 50-60Hz. El cable suministrado en la confección tiene que ser insertado en la toma apta la que está en el panel posterior.

El conmutador se encenderá inmediatamente, independientemente de si tiene conexiones activas. Una vez hecha la comprobación del sistema, el LED de alimentación (Power) se encenderá de color rojo para indicar un correcto funcionamiento de aparato.

3.5 Panel Frontal

El panel frontal del conmutador dispone de varios LEDs que permiten determinar el correcto funcionamiento del aparato y, en caso de fallo, diagnosticar el mismo.

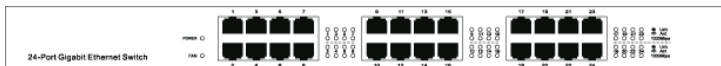

LED	Descripción
Power	Encendido ininterrumpidamente de color rojo cuando esta alimentado.
FAN (1-2)	Encendido ininterrumpidamente cuando funciona correctamente
LINK/ACT	Parpadeante durante la transmisión de datos y encendido de color verde para indicar un enlace Fast Ethernet.
1000 Mbps	Parpadeante durante la transmisión de datos y encendido de color verde para indicar un enlace Gigabit Ethernet.



Si el LED Power (alimentación) esta apagado, verificar que:

- Hay corriente en el enchufe
- Esta usando el alimentador incluido con el producto

- Verificar que el cable de red este correctamente conectado a los puertos del PC y del conmutador

Si el LED Link/Act (Conexión/ Transmisión) esta apagado, verificar que:

- Verificar que el cable de red este correctamente conectado a los puertos del PC y del conmutador
- Esta usando el alimentador incluido con el producto
- Verificar que el dispositivo con el que se esta intentado comunicar este encendido
- El cable Ethernet no tenga más de 100 m

3.7 Panel Posterior



PUERTA	DESCRIPCIÓN
POWER Jack	Tiene que ser junto a la red eléctrica por medio del cable suministrato. Suporta en entrada 100-240V y en alternada 50 o 60Hz.

4 Soporte Técnico

Consultar el sitio Web <http://www.atlantis-land.com> o contactarnos a las siguientes direcciones de correo electrónico (info@atlantis-land.com o tecnicos@atlantis-land.com).

Atlantis Land SpA
Viale De Gasperi 122
20017 Mazzo di Rho (MI)

Tel: +39.(0)2.93906085 (Fax: +39.(0)2.93906161) Help Desk :+39.(0)2.9390763

APPENDIX A: Technical Specifications

General	
Standards	IEEE802. 10Base-T IEEE802. u 100Base-TX IEEE802. ab 1000Base-T
Topology	Star
Protocol:	CSMA/CD
Data Transfer Rate:	Ethernet: 10Mbps (Half Duplex), 20Mbps (Full Duplex) Fast Ethernet: 100Mbps (Half Duplex), 200Mbps (Full Duplex) Gigabit Ethernet: 2000Mbps (Full Duplex)
Network Cables:	10Base-T: UTP category 3, 4, 5 cable (maximum 100m) EIA/TIA- 568 100 STP (maximum 100m) 100Base-TX: UTP category 5, 5e cable (maximum 100m) EIA/TIA- 568 100 STP (maximum 100m) 1000Base-TX: UTP category 5, 5e cable (maximum 100m) EIA/TIA- 568 100 STP (maximum 100m)
Number of Ports:	16/24 10/100/1000Mbps Auto-Negotiation RJ-45 ports
LED Indicators:	Power, FAN, Link/ACT, 1000 Mbps
Transfer Method:	Store-and-forward
MAC Address Learning:	Automatically learning, automatically aging
Frame Filter Rate:	10Base-T: 14880pps/Port 100Base-Tx: 148800pps/Port 1000Base-T: 1488000pps/Port
Frame Forward Rate:	10Base-T: 14880pps/Port 100Base-Tx: 148800pps/Port 1000Base-T: 1488000pps/Port
Physical and Environmental	
Power Supply Output:	100-240V ~ 50-60Hz 0.6A
Operating Temperature:	0°C ~ 40°C gradi Celsius



Storage Temperature:	-10°C ~ 60°C gradi Celsius
Humidity:	Operating: 10% ~ 90%, Storage: 5% ~ 90%
Dimensions:	440mm x 180mm x 44mm

All rights registered

Microsoft and Windows are registered trademarks of Microsoft Corporation

All trade names and marks are registered trademarks of respective companies

Specifications are subjected to change without prior notice. No liability for technical errors and/or omissions



Atlantis Land S.p.A.
Viale De Gasperi, 122
Mazzo di Rho – MI – Italy
info@atlantis-land.com

Where solutions begin

ISO 9001:2000 Certified Company

Download from [Www.Somanuals.com](http://www.Somanuals.com). All Manuals Search And Download.

Free Manuals Download Website

<http://myh66.com>

<http://usermanuals.us>

<http://www.somanuals.com>

<http://www.4manuals.cc>

<http://www.manual-lib.com>

<http://www.404manual.com>

<http://www.luxmanual.com>

<http://aubethermostatmanual.com>

Golf course search by state

<http://golfingnear.com>

Email search by domain

<http://emailbydomain.com>

Auto manuals search

<http://auto.somanuals.com>

TV manuals search

<http://tv.somanuals.com>