



# *AD-530*

## **Service Manual**

---

---

**American Dryer Corporation**  
88 Currant Road  
Fall River MA 02720-4781  
Telephone: (508) 678-9000 / Fax: (508) 678-9447  
e-mail address: [service@amdry.com](mailto:service@amdry.com)

040696

**ADC Part No. 450161**

# Retain This Manual In A Safe Place For Future Reference

American Dryer Corporation products embody advanced concepts in engineering, design, and safety. If this product is properly maintained, it will provide many years of safe, efficient, and trouble-free operation.

*ONLY properly licensed technicians should service this equipment.*

**OBSERVE ALL SAFETY PRECAUTIONS** displayed on the equipment or specified in the installation/operator's manual included with the dryer.

**WARNING: UNDER NO CIRCUMSTANCES should the door switch or the heat circuit devices ever be disabled.**

**WARNING: The dryer must never be operated with any of the back guards, outer tops, or service panels removed. PERSONAL INJURY or FIRE COULD RESULT.**

We have tried to make this manual as complete as possible and hope you will find it useful. ADC reserves the right to make changes from time to time, without notice or obligation, in prices, specifications, colors, and material, and to change or discontinue models.

## Important

For your convenience, log the following information:

DATE OF PURCHASE \_\_\_\_\_ MODEL NO. AD-530

DISTRIBUTOR'S NAME \_\_\_\_\_

Serial Number(s) \_\_\_\_\_

Replacement parts can be obtained from your distributor or the ADC factory. When ordering replacement parts from the factory, you can FAX your order to ADC at (508) 678-9447 or telephone your orders directly to the ADC Parts Department at (508) 678-9010. Please specify the dryer model number and serial number in addition to the description and part number, so that your order is processed accurately and promptly.

The illustrations on the following pages may not depict your particular dryer exactly. The illustrations are a composite of the various dryer models. Be sure to check the descriptions of the parts thoroughly before ordering.

**INSTRUCTIONS TO BE FOLLOWED IN THE EVENT THE USER SMELLS GAS MUST BE POSTED IN A PROMINENT LOCATION. THE INSTRUCTIONS TO BE POSTED SHALL BE OBTAINED FROM THE LOCAL GAS SUPPLIER.**

# Table of Contents

<b>SECTION I</b>	
<b>IMPORTANT INFORMATION</b> .....	3
A. SAFETY PRECAUTIONS .....	3
<b>SECTION II</b>	
<b>MAINTENANCE</b> .....	4
A. CLEANING .....	4
B. ADJUSTMENTS .....	5
C. LUBRICATION .....	5
<b>SECTION III</b>	
<b>INSTALLATION REQUIREMENTS</b> .....	6
A. ENCLOSURE AIR SUPPLY AND EXHAUST REQUIREMENTS .....	6
B. ELECTRICAL AND GAS REQUIREMENTS .....	7
C. OPERATIONAL SERVICE CHECK PROCEDURE .....	7
<b>SECTION IV</b>	
<b>DESCRIPTION OF PARTS</b> .....	8
A. Control Panel Assembly .....	8
B. Control / Relay Box .....	8
C. Coin Box Assembly .....	8
D. Main Door Switch (Steel Hinge) .....	8
E. Main Door Switch (Hinge Blocks) .....	9
F. Lint Screen/Drawer .....	9
G. Tumbler .....	9
H. Tumbler Bearing and Pulley Arrangement .....	10
I. Idler Arm / Impellor Mount Assembly .....	10
J. Drive Motor / Pulley Arrangement .....	10
K. Temperature Sensor .....	11
L. Gas Burner .....	11
M. Sail Switch .....	11
N. Hi-Limit Thermostat .....	12
O. Lint Basket Switch .....	12
P. Lint Basket .....	12
<b>SECTION V</b>	
<b>SERVICE</b> .....	13
A. CONTROLS (Computer) .....	13
B. BURNER CONTROLS (Gas) .....	18

F. THERMOSTATS AND TEMPERATURE SENSOR.....	21
G. SAIL SWITCH ASSEMBLY .....	23
H. FRONT PANEL AND MAIN DOOR ASSEMBLIES .....	24
I. TUMBLER AND BEARING ASSEMBLY .....	27
J. IDLER & BEARING ASSEMBLY .....	28
L. TUMBLER (BASKET) .....	29
M. V-BELTS .....	32
N. MOTOR .....	33
O. REPLACING THE IMPELLOR MOUNT ASSEMBLY .....	33

**SECTION VI**

<b>TROUBLESHOOTING .....</b>	<b>35</b>
------------------------------	-----------

A. PHASE 5 COIN SYSTEM DIAGNOSTICS .....	35
B. NO HEAT CONDITION (Gas Models) .....	38
E. NO START CONDITION.....	42
F. NO DISPLAY CONDITION.....	43
G. "dSFL" DISPLAY CONDITION .....	45
H. "dOOr" DISPLAY CONDITION .....	46

**SECTION VII**

<b>TECHNICAL INFORMATION .....</b>	<b>47</b>
------------------------------------	-----------

A. DATA LABEL .....	47
B. USING A MANOMETER .....	48
C. L.E.D. DISPLAY CODES .....	49
D. COMPUTER LOGIC AND WIRING DIAGRAM .....	50

# SECTION I

## IMPORTANT INFORMATION

### A. SAFETY PRECAUTIONS

1. Do not store gasoline or other flammable vapors and liquids in the vicinity of this or any appliance.
2. Purchaser / user should consult the local gas supplier for proper instructions to be followed in the event the user smells gas. The instructions should be posted in a prominent location.
3. Dryer must be exhausted to the outdoors.
4. Although the American Dryer is a very versatile machine there are some articles that, due to fabric composition or cleaning method, should not be dried in it.

**WARNING:** Dry only water washed fabrics. Do not dry articles spotted or washed in dry cleaning solvents, a combustible detergent or "all purpose cleaners." Fire or explosion could result.

**WARNING:** Do not dry rags or articles coated with gasoline, kerosene, paint, wax, oil, or grease. Fire or explosion could result.

**WARNING:** Do not dry mop heads. Contamination by wax or flammable solvents will create a fire hazard.

**WARNING:** Do not use heat for drying articles that contain plastic, foam or sponge rubber, or similarly textured like materials. Drying in a heated tumbler may cause damage to plastics or rubber and also may be a fire hazard.

5. A program should be established for the inspection and cleaning of the lint in the burner area and exhaust duct work. The frequency of inspection and cleaning can best be determined from experience at each location.

**WARNING:** The collection of lint in the burner / oven area and exhaust duct work can create a potential fire hazard.

6. For personal safety, the dryer must be electrically grounded in accordance with local codes and or the national electric code ANSI/NFPA NO. 70 (latest edition).
7. Under no circumstances should the dryer door switch or heat circuit safety devices ever be disabled.
8. Read and follow all caution and direction labels attached to dryer.

**WARNING:** Children should not be allowed to play on or in the dryers. Children should be supervised if near dryers in operation.

# SECTION II

## MAINTENANCE

### A. CLEANING

A program or schedule should be established for periodic inspection, cleaning and removal of lint from various areas of the dryer, as well as, throughout the duct work system. The frequency of cleaning can best be determined from experience at each location. Maximum operating efficiency is dependent upon proper air circulation. The accumulation of lint can restrict this air flow. If the guidelines in this section are met, your American Dryer will provide many years of efficient, trouble free, and most importantly, safe operation.

**WARNING:** Lint from most fabrics is highly combustible. The accumulation of lint can create a potential fire hazard.

#### SUGGESTED INTERVAL

#### FUNCTION

DAILY

Clean lint from lint screen. Inspect lint screen and replace if torn.

90 DAYS

Remove lint accumulation from lint chamber thermostats and sensors.

**WARNING:** To avoid the hazard of electrical shock, discontinue electrical supply to dryer.

Remove lint from the motor air vents and surrounding area.

Inspect and tighten all set screws (i.e.; pulleys, idler bearings, tumbler bearings).

**IMPORTANT:** Lint accumulation will restrict internal motor air flow, causing overheating and irreparable damage. Motor failure due to lint accumulation will void the manufacturer's warranty

120 DAYS

On gas and electric models remove lint from gas burner area with a dusting brush or vacuum cleaner attachment.

On steam dryers, clean the coil. Proper cleaning of steam coils is necessary to prevent lint build-up between the fins. When cleaning the coil, be extremely careful not to bend the aluminum fins, which will also reduce airflow. If the fins are bent, straighten them by using a comb. Fin combs are available from local air conditioning supply houses. Regular cleaning will prevent lint build-up and blockage of the coil.

6 MONTHS

Inspect and remove lint accumulation in the customer-furnished exhaust duct work system. Inspect exhaust back draft dampers to insure they are not binding. Inspect and remove all lint accumulation from in and around control box area including coin acceptors. Clean lint accumulation from around tumbler wrapper area.

**IMPORTANT:** The accumulation of lint in the exhaust duct work can create a potential fire hazard

AS REQUIRED

In cleaning and care of the cabinet, avoid using harsh abrasives. A product intended for the cleaning of appliances is recommended.

## **B. ADJUSTMENTS**

### **SUGGESTED INTERVAL**

### **FUNCTION**

6 MONTHS

Motor and drive belts should be examined. Cracked or seriously frayed belts should be replaced. Tighten loose belts when necessary, and check belt alignment.

Complete operational check of controls and valves.

Complete operational check of all safety devices (door switches, sail switch, burner and lint chamber thermostats.)

12 MONTHS

Inspect bolts, nuts, screws non permanent gas connections, (unions orifices, etc.) electrical terminals, and grounding connections.

## **C. LUBRICATION**

The new bearings, idler bearings and tumbler bearing are sealed lubrication is not necessary.

# SECTION III

## INSTALLATION REQUIREMENTS

Installation should be performed by competent technicians in accordance with local and state codes. In the absence of these codes, installation must conform to applicable American & National Standards.

ANSI Z223.1 (LATEST EDITION) NATIONAL FUEL GAS CODE

ANSI/NFPA NO. 70 (LATEST EDITION) NATIONAL ELECTRIC CODES

### A. ENCLOSURE AIR SUPPLY AND EXHAUST REQUIREMENTS

**NOTE:** The following information is very brief and general. For a detailed description refer to the installation booklet for coin machines.

Bulkheads and partitions around the dryer should be made of non-combustible materials. Allowances should be made for the opening and closing of the control door and lint door. Also, allowances should be made in the rear for ease of maintenance. (Refer to installation manual for recommended distances and minimum allowances required.)

When the dryer is operating, it draws in room air, heats it, passes this air through the tumbler, and exhausts it out the building. Therefore, the room air must be continually replenished from the outdoors. If the make up air is inadequate, drying time and drying efficiency will be adversely affected. Also, on gas machines Ignition problems and sail switch "fluttering" problems may result and on a electric machine, premature electric element failure may result. Air supply must be given careful consideration to insure proper performance of each dryer.

**IMPORTANT:** Make up air must be provided from a source free of dry cleaning fumes. Make up air that is contaminated by dry cleaning fumes will result in irreparable damage to motors and other dryer components.

Exhaust duct work should be designed and installed by a competent technician. Improperly sized duct work will create excessive back pressure, which will result in slow drying, increased use of energy, and shut down of the burner by the air flow (sail) switch. (Refer to installation manual for more detail.)

**CAUTION:** Improperly sized, installed or maintained (cleaned) exhaust duct work creates a potential fire hazard.



## **B. ELECTRICAL AND GAS REQUIREMENTS**

It is your responsibility to have all electrical connections made by a properly licensed and competent electrician to assure that the electrical installation is adequate and conforms with local and state regulations or codes. In the absence of such codes, all electrical connections, material, and workmanship must conform to the applicable requirements of the National Electric Code ANSI/NFPA NO. 79-(latest edition).

**IMPORTANT:** Failure to comply with these codes or ordinances, and or the requirements stipulated in this manual, can result in personal injury or component failure.

The dryer installation must meet the American National Standard, National Fuel Gas Code ANSI Z223.1 (latest edition), as well as, local codes and ordinances and must be done by a qualified technician.

**NOTE:** Undersized gas piping will result in ignition problems and slow drying and can create a safety hazard.

The dryer must be connected to type of gas (natural or L.P.) indicated on the dryer data label. If this information does not agree with the type of gas available, contact the distributor who sold the dryer or contact the factory.

The gas input ratings shown on the dryer data label are for elevations up to 2,000 feet, unless elevation requirements of over 2,000 feet were specified at the time the dryer order was placed with the factory. The adjustment for dryers in the field for elevations over 2,000 feet are made by changing the burner orifices. If this adjustment is necessary, contact the distributor's who sold the dryer or contact the factory.

**NOTE:** Any burner changes must be made by a qualified technician.

## **C. OPERATIONAL SERVICE CHECK PROCEDURE**

After performing any service or maintenance function, an operational check should be performed to insure that all components are performing properly.

1. Make a complete operational check of all the operating controls to insure that the timing is correct, temperature selection switches are functioning properly.
2. Make a complete operational check of all safety related circuits, door switch(es), hi-limit thermostat, sail switch, cycling thermostats, etc.

# SECTION IV

## DESCRIPTION OF PARTS

### A. Control Panel Assembly

The coin panel assembly consists of the coin acceptor, a display board, and the keypad label. The coin acceptor is used to acknowledge that the proper coin has been put through the acceptor. The display board will just display the time, temperature in a readable number of letter character. The keypad label is used to input a Hi, Low, or Perm Press selection for the dryer to start.

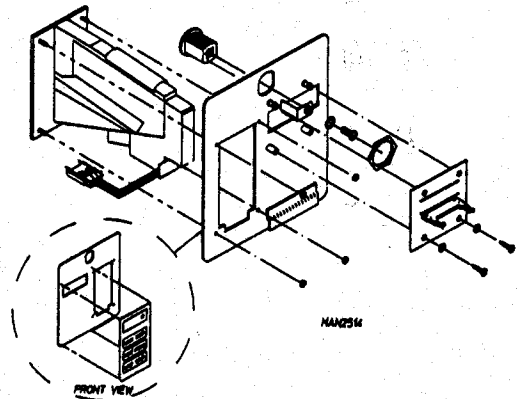

### B. Control / Relay Box

The control / relay box is located in the back of the machine in the middle top section. The function of the control / relay box is to compile various signals from the computer or the incoming voltage and transfer the signals to the motor/heat circuits, when the computer executes these various signals.

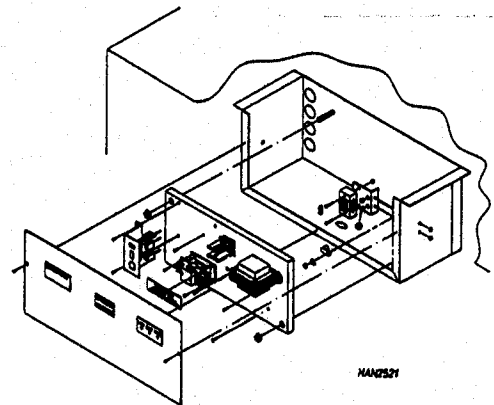

### C. Coin Box Assembly

The coin box is located below the left and right coin panels. It is a good size triangular box. When the coin passes through the acceptor, the optic switch sends a signal to the computer and the coin then falls into the coin box.

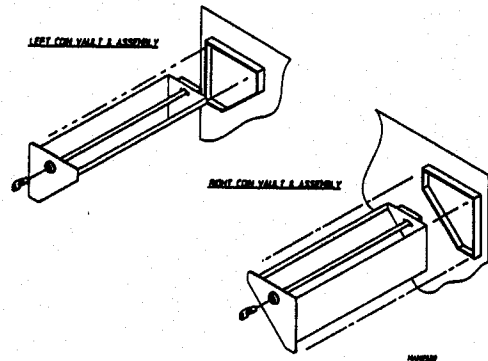

### D. Main Door Switch (Hinge Blocks)

The main door switch is located behind the main door on the right hand side. When the main door is opened, the switch will also open preventing the dryer from operating. The main door switch is a safety device and should never be disabled.

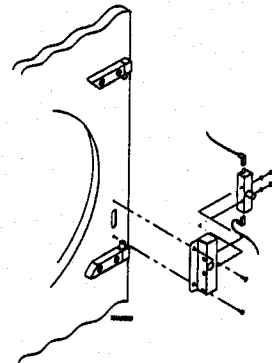

## E. Main Door Switch (Steel Hinge)

The main door switch is located behind the main door on the right hand side. When the main door is opened, the switch will also open preventing the dryer from operating. The main door switch is a safety device and should never be disabled.

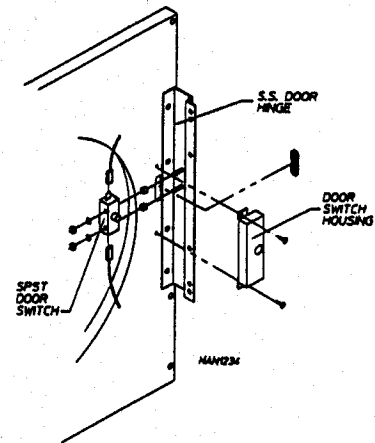

## F. Tumbler

The tumbler consists of three ribs and a perforated basket along with a front and back which are riveted together as an assembly. The tumbler also consists of tie rods which attach the tumbler to the drive system in the rear. The felt collar helps to keep lint from accumulating behind the basket.

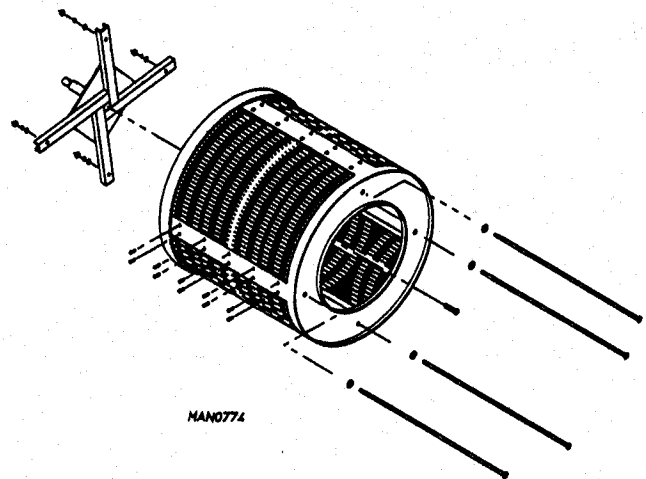

## G. Tumbler Bearing and Pulley Arrangement

The tumbler bearing and the pulley arrangement is located (viewing from the rear of the dryer) approximately at the upper center of the dryer. The arrangement consists of a pulley, bearing box, and bearings which serve to adjust, drive, and support the tumbler. The bearing box has various nuts and bolts that are made to adjust the basket vertically and horizontally.

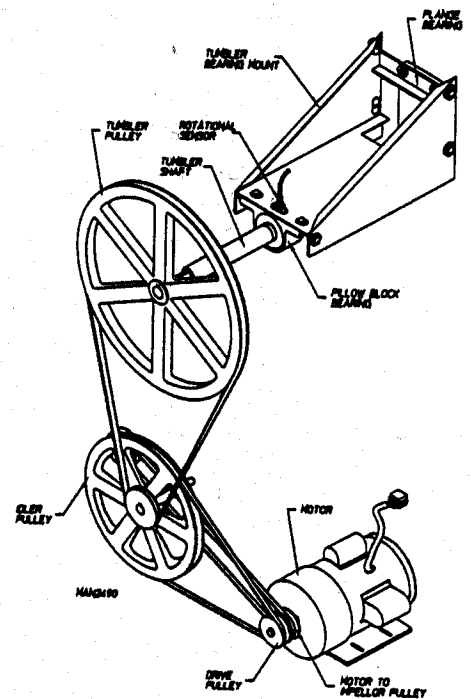

## H. Idler Arm / Impellor Mount Assembly

The idler arm assembly is located in the back of the dryer, it is attached to the impellor mount. The main purpose of the idler assembly is to reduce the speed of the motor in turn increasing the torque of the basket pulley. The impellor (fan) is also affixed to this mount, its main purpose is to provide the air flow throughout the machine.

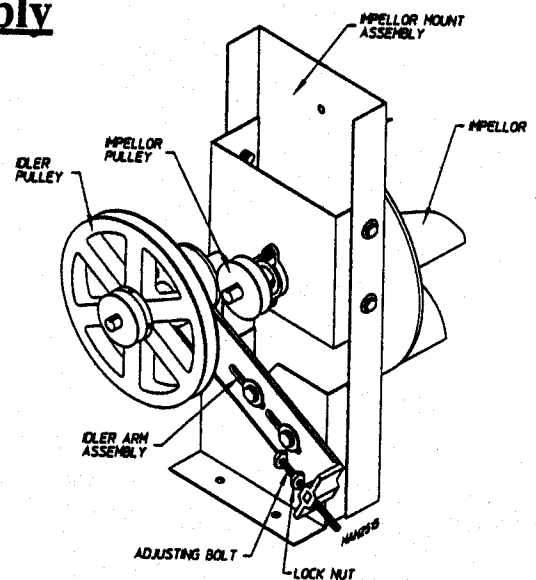

## I. Drive Motor / Pulley Arrangement

The AD-530 has different kind of drive system. There are two motor pulleys, one drives the idler arm assembly by the basket pulley and the other motor pulley drives a set of bearings that rotates the impellor.

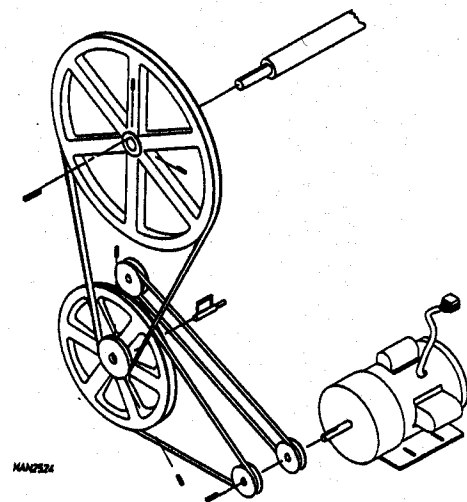

## J. Temperature Sensor

The temperature sensor is used as a transducer that converts heat into micro-amps. The computer board then uses these micro-amps to calculate the temperature. This sensor is located under the basket(s) on the right hand side.

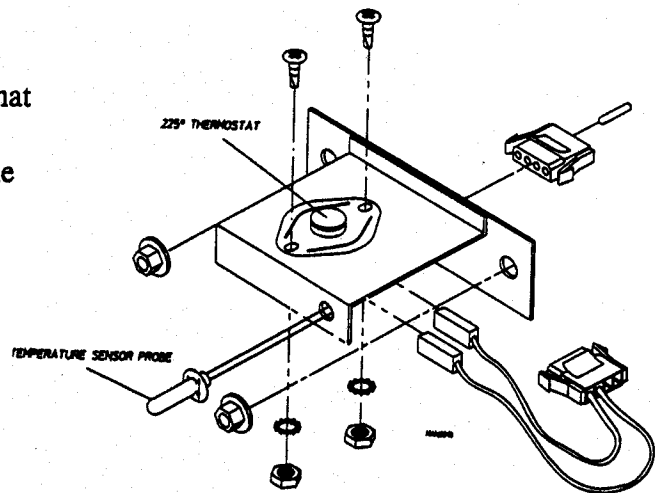

## K. Gas Burner

The gas burner assembly consists of the burner tube, orifice (the orifice has a hole in it to allow gas to flow through. The hole size varies with different elevations, and different BTU's), gas valve (which can be set up for natural gas or L.P.), spark ignitor, and probe assembly. The D.S.I. Module is also included on this burner assembly.

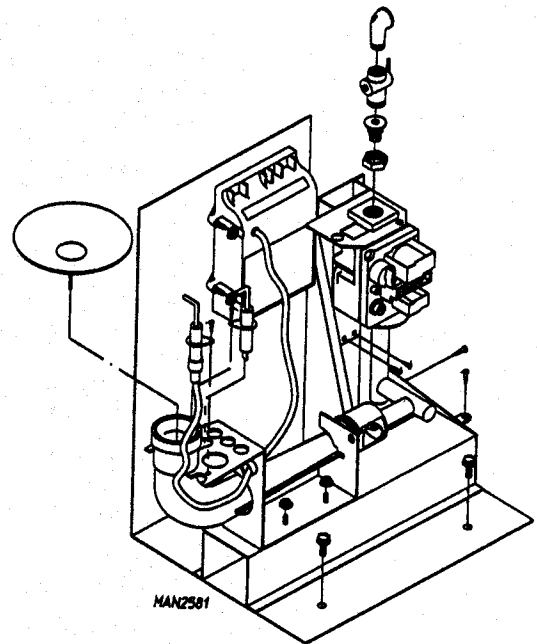

## L. Sail Switch

The sail switch consists of a round plate on a lever arm which acts like an actuator for a micro-switch. When the blower motor comes on, it draws air from the burner. This creates a negative pressure inside the basket area, and this negative pressure pulls in the round damper which activates the sail switch. If there is improper air flow, the damper will not pull in, preventing the burner from coming on. Improper air flow can be caused by improperly designed exhaust ducting, where the duct run is too long or has too many sharp bends in it. It can also be caused by a lack of make up air or any obstruction such as a backdraft damper sticking or lint build up will also cause the same effect.

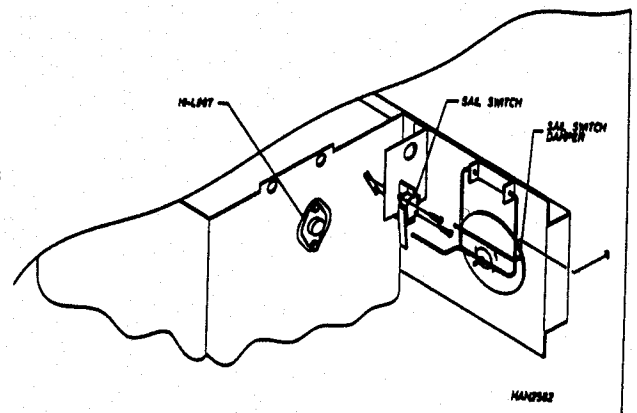

## M. Hi-Limit Thermostat

The burner hi-limit thermostat is another safety device that we use on the dryer. The hi-limit is located in the burner area. The Hi-Limit thermostat cuts off the heat if the temperature should reach 330° or higher. Under normal conditions the only way this device would shut off the heat is when the air flow changes to the extent of causing the intense heat from the burner to trip the thermostat.

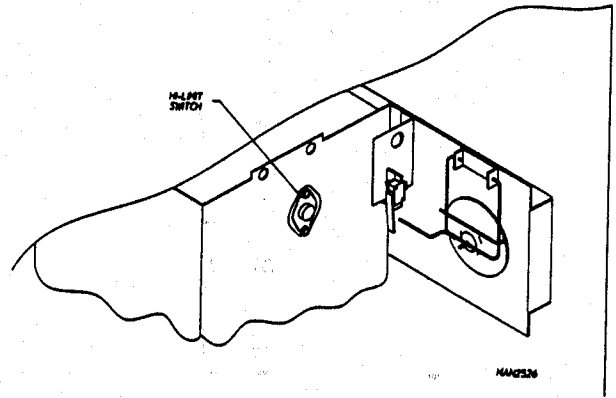

## N. Lint Basket Switch

The lint basket switch is located under the basket on the right side. It is another added safety device that stops the operation of the dryer when the lint drawer is opened. This device and the door switch are the two safety switches designed to halt the tumbler.

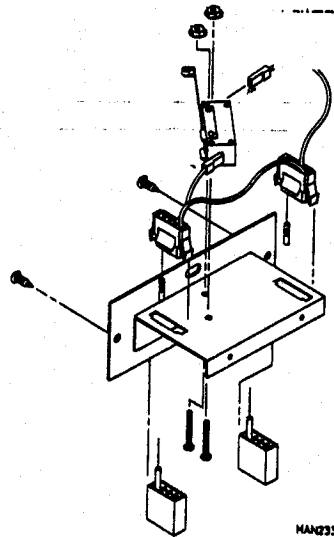

## O. Lint Basket

The lint basket is located under the basket(s) of each pocket. It is a fairly large draw that is designed to be right in the main path of the air flow, to catch any lint that happens to come out of the articles being dried.

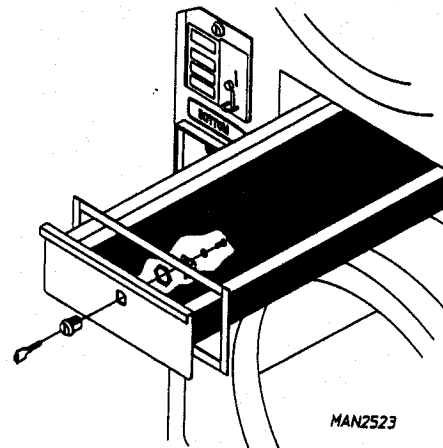

# SECTION V

## SERVICE

All electrical/mechanical service or repairs should be made with the electrical power to the dryer disconnected (power off).

**WARNING:** Personal injury could result.

The information provided in this section should not be misconstrued as a device for use by untrained persons making repairs. Service work should be performed by competent technicians in accordance with local state and federal codes. When contacting the factory for assistance, always have the dryer model and serial numbers available.

**CAUTION:** Observe all safety precautions displayed on the dryer or specified in this manual before and while making repairs.

The information provided will help isolate the most probable components associated with the difficulty described. The experienced technician realizes, however, that a loose connection or broken/shorted wire may be at fault where electrical components are concerned, not necessarily the suspected component itself. Electrical parts should always be checked for failure before being returned to the factory.

**IMPORTANT:** YOU MUST DISCONNECT and LOCKOUT THE ELECTRIC SUPPLY and THE GAS SUPPLY BEFORE ANY COVERS or GUARDS ARE REMOVED FROM INSTALLATION, or TESTING OF ANY EQUIPMENT PER OSHA (Occupational Safety and Health Administration) STANDARDS.

### A. Controls (Computer)

#### TO REPLACE COMPUTER

1. Disconnect power to dryer.
2. Open coin panel (1 lock in the center of the coin panel).
3. Disconnect the display harness from the computer board (push the two tabs on the side of the connector outwards)
4. Disconnect the optic switch harness from the computer, (squeeze the tabs on the side of the connector).
5. Disconnect the keypad connector from the computer board keypad harness (simply pull straight out).

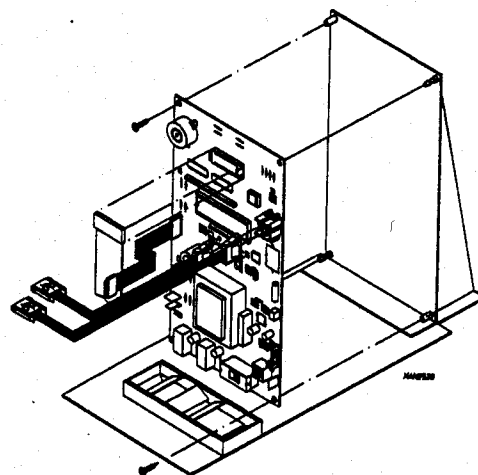

6. Disconnect the 9 pin main computer harness from the computer, (squeeze the one tab on the connector and pull straight back).
7. Disconnect the green ground wire from the computer board.
8. Remove the two Phillips head screws that secure the computer to the panel. Remove the board from the panel by pulling at the corners of the board.
9. Replace in the reverse steps of the above.
10. Re-establish power to the dryer.

**NOTE:** Use caution when handling the M.P. Controller as it can be easily damaged by static electricity.

### **TO REPLACE KEYPAD**

1. Discontinue power to dryer.
2. Open the coin panel and disconnect the keypad ribbon connector from the ribbon cable it is plugged into.
3. Peel the keypad from the front of the control panel taking care to avoid scratching the panel.
4. Clean any adhesive residue from the panel.
5. Peel off paper backing from new keypad.
6. Align the display window on the keypad with the cutout in the control panel and press in place.
7. Connect keypad ribbon to the board and reconnect power to the dryer.
8. Test for operation by pressing each temperature selection.

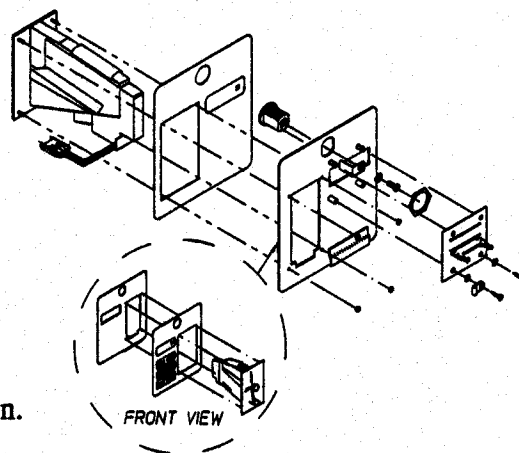

MAN2529

### **TO REPLACE COIN ACCEPTOR**

1. Discontinue power to the dryer.
2. Open the coin panel.
3. Remove the four (4), 3mm nuts holding the coin acceptor to the panel
4. Unplug optic switch harness connector.
5. Pull coin acceptor out gently.
6. Reverse procedure for installing new acceptor.



## **TO REMOVE OPTIC SWITCH**

1. Disconnect power to dryer
2. Open top and bottom coin panel.
3. Remove optic switch from the coin acceptor (one screw).
4. Unplug optic switch connector.
5. Remove optic switch from machine.
6. Reverse procedure for installing new optic switch.

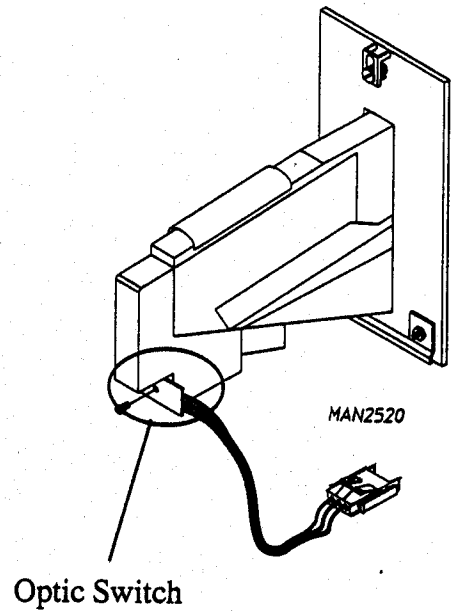

## **TO REPLACE MOTOR CONTACTOR 2-POLE, 24VAC**

1. Discontinue power to dryer.
2. Remove back guard.
3. Remove relay box cover.
3. Remove both screws securing motor contactor to the electrical panel.
4. Remove all wires from contactor (Note: make sure each wire is marked with location removed from).
5. Install new contactor in reverse procedure
6. Re-establish power to dryer.

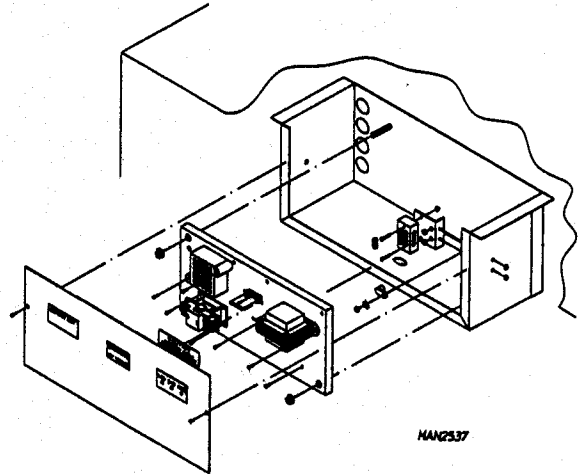

## **TO REPLACE GAS VALVE**

1. Discontinue power to dryer
2. Close the union shut-off located just before the gas valve and remove the two wires on top of the gas valve.
3. Break & loosen union nut between union shut-off and gas valve.
4. Remove the four (4) screws holding the two pipe brackets on each side of the gas valve.
5. Remove gas valve and manifold (still attached) from dryer.
6. Remove the single port manifold from the output side of the gas valve.
7. Remove the union tail piece and nut from the input of valve (a 1/2" Allen wrench is required)
8. Reverse procedure for installing new valve.

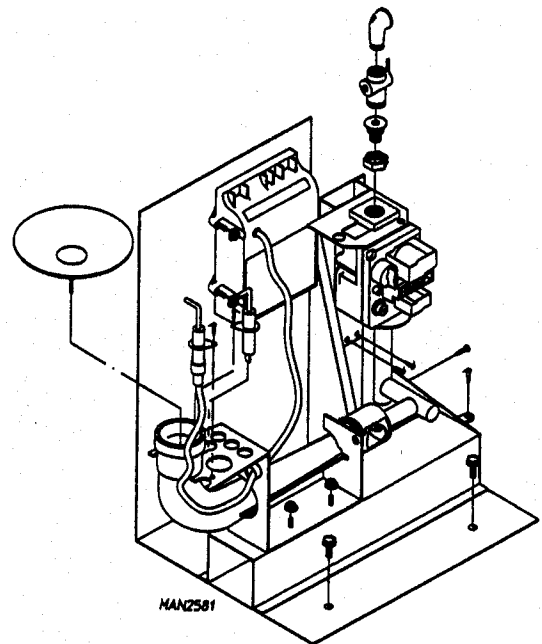

**IMPORTANT:** Pipe dope must be applied to manifold before installing it into new valve.

## **REPLACE UP-SHOT BURNER TUBE ASSEMBLY** (see Illustration below)

1. Discontinue power to dryer
2. Remove the two (2) hex nuts that hold the burner tube bracket to the burner train bracket.
3. Lift burner tube and bracket up over the two (2) weld studs that those two hex nuts were affixed to in step 2.
4. Disconnect the high voltage wire and the flame sensor wire from the D.S.I. module.
5. Re-assemble new up-shot burner tube assembly (p/n: 880741) in reverse procedure.

**IMPORTANT:** Do not wrap the high voltage wire and flame probe wires together, improper operation may result. They may run alongside each other.

**IMPORTANT:** Make sure the gap from the ignitor to the top of the burner tube is  $1/8" \pm 1/32"$ .

## **TO REPLACE FLAME SENSOR OR IGNITOR PROBE**

1. Discontinue power to dryer.
2. To remove either flame sensor or ignitor probe one screw holds them to the burner tube bracket.
3. If replacing flame sensor simply remove the screw and disconnect the connector on the flame sensor, remove it.
4. If replacing ignitor probe, remove screw, disconnect high voltage wire from D.S.I. module and remove the probe and high voltage wire from the bracket.
5. Replace new item(s) in reverse procedure.

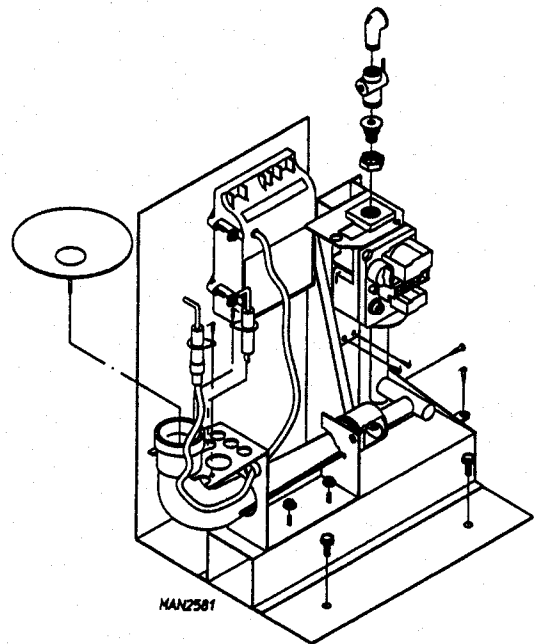

**IMPORTANT:** Do not wrap the high voltage wire and flame probe wires together, improper operation may result. They may run alongside each other.

**IMPORTANT:** Make sure the gap from the ignitor to the top of the burner tube is  $1/8" \pm 1/32"$ .

## **B. BURNER CONTROLS (Gas)**

The illustration below shows you the gas valve assembly and the gas chamber.

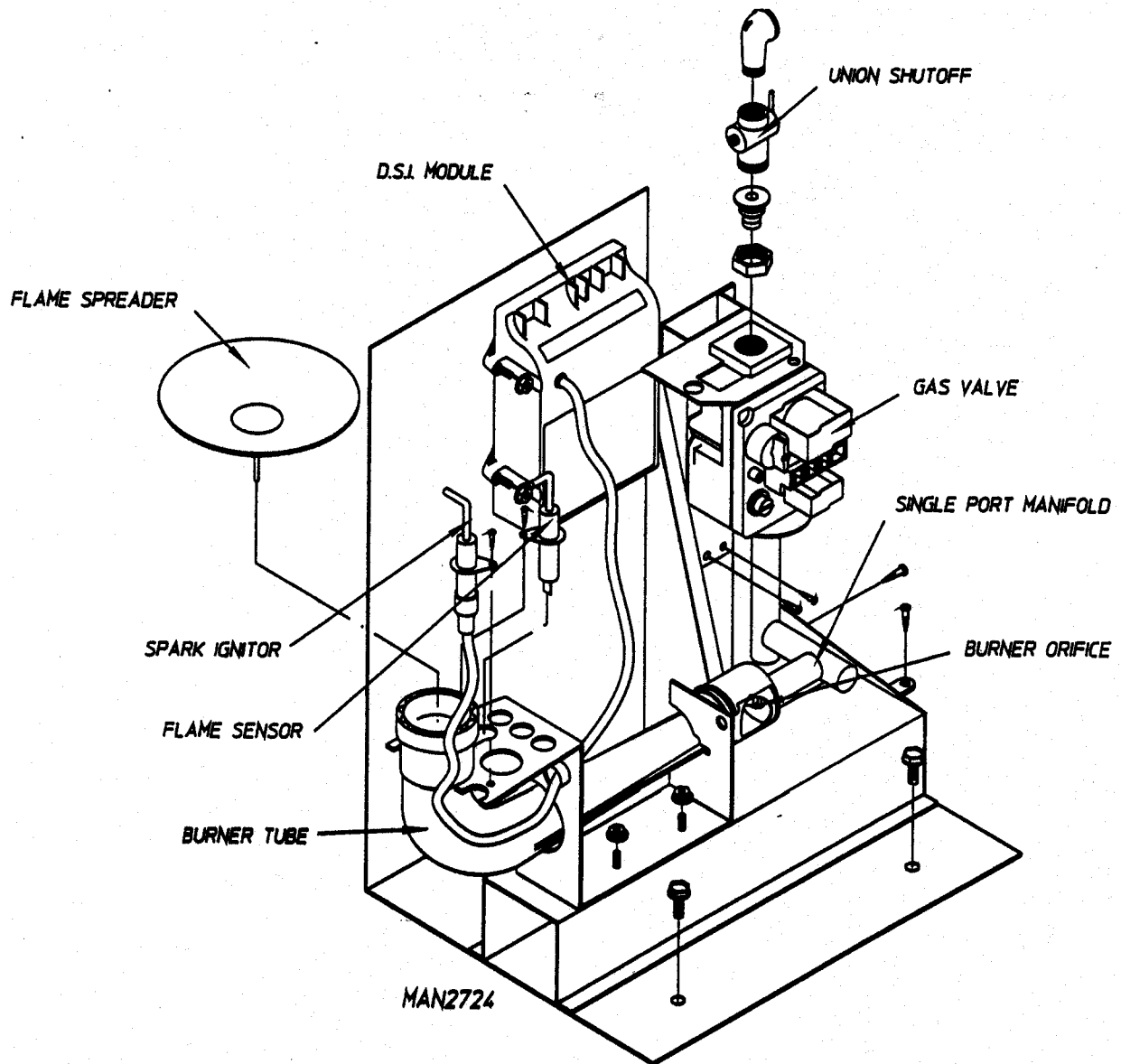

## TO REPLACE MAIN BURNER ORIFICE

1. Refer to "TO REPLACE GAS VALVE" and follow steps one through five.
2. Unscrew main burner orifice and replace.

**NOTE:** Use extreme care when removing and replacing orifice. The orifice is made of brass and can be easily damaged.

3. Reverse the removal procedure for re-installing.

**WARNING:** Test all connections for leaks by brushing on a soapy water solution. "Never test for leaks with flame."

## TO TEST AND ADJUST GAS (WATER COLUMN) PRESSURE

There are two (2) types of devices commonly used to measure water column pressure. They are spring/mechanical type gauges and manometers. The spring/mechanical type gauge is not recommended because it is easily damaged and not always accurate. One form of a manometer is a Hydro-Gauge which simply consists of an inner and outer tube. When this tube is filled with water and pressure is applied the water in the inner tube decreases giving you your gas pressure reading.

**NOTE:** Manometers are available from the factory by ordering part number 122804.

1. Test gas water column (w.c.) pressure.
  - A. Connect water column test gauge connection to gas valve pressure tap (1/8 N.P.T). This pressure tap is located on the outlet (downstream) side of the valves.
  - B. Start the dryer. With burner on, the correct water column reading in inches would be:

NATURAL GAS: 3.5-4 INCHES W.C.  
L.P. GAS: 10.5-11 INCHES W.C.

2. To adjust water column pressure: For natural gas models remove vent cap. Turn the slotted adjustment screw located on top of the valve next to the terminals. Turn clockwise to increase manifold pressure and counterclockwise to decrease. There is no regulator in the valve for L.P. gas models. The regulator for L.P. models must be provided externally to the dryer.

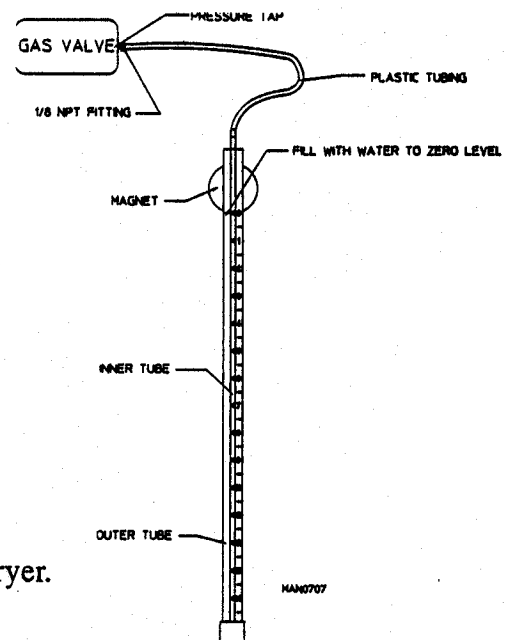

**NOTE:** If correct w.c. pressure cannot be achieved, problems may be due to an undersized gas supply line, a faulty or underrated gas meter, etc.

### **TO CONVERT FROM NATURAL TO L.P. GAS**

1. Disconnect electrical power to dryer.
2. Close all shut-off valves in dryer gas supply line.
3. Disconnect gas valve wiring.

**NOTE:** Identify location of each wire for correct re-installation.

4. Break union connection (nut) between union shut off and gas valve.
5. Loosen and remove screws (4) from pipe brackets holding the gas valve/manifold assembly to the gas valve plate.
6. Remove gas valve/manifold assembly from dryer.
7. Unscrew main burner orifice and replace with L.P. orifices supplied.

**NOTE:** Use extreme care when removing and replacing orifices. These orifices are made of brass which are easily damaged.

8. To convert gas valve for use with L.P. gas, refer to instructions included in kit envelope (#f92-0737) supplied.
9. Reverse procedure for installing valve manifold assembly to dryer.

**IMPORTANT:** External regulation of a consistent gas pressure of between 10.5 and 11.0 inches water column must be provided.

10. Open all shut off valves and test for leaks.

**IMPORTANT:** Do not test for leaks with an open flame. Use soapy water solution or a product intended for that purpose.

11. Operate dryer through one complete cycle to insure proper operation.

**IMPORTANT:** Conversion should be performed by competent technicians in accordance with local and state codes. Improper assembly or adjustment can cause hazardous condition.

**NOTE:** There is no regulator provided in an L.P. dryer. The water column pressure must be regulated at the source (L.P. tank), or an external regulator must be added to each dryer.

12. Call American Dryer Corp. for L.P. conversion kits or the proper orifices for natural or L.P. gas.

### **TO REPLACE D.S.I. MODULE**

1. Discontinue power to the dryer
2. Remove the wires connected to the terminal strip at the bottom of the module.
3. Remove the soft orange high voltage wire from the module.
4. Remove the four (4) pal nuts securing the module to the mounting bracket.
5. Replace module by reversing process.

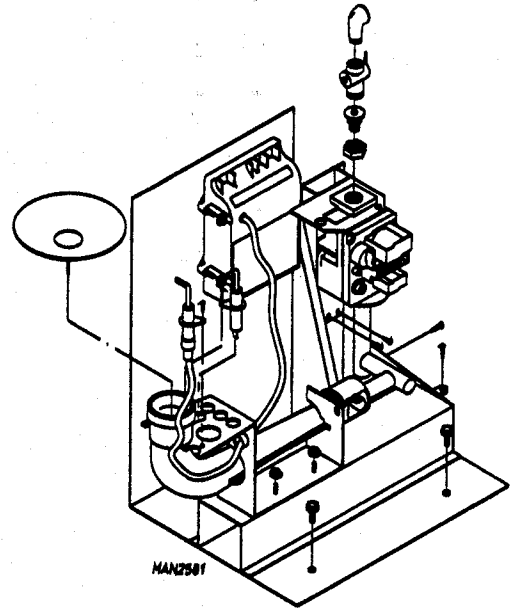

## **F. THERMOSTATS AND TEMPERATURE SENSOR**

### **TO REPLACE HI-LIMIT THERMOSTAT (330°)**

This thermostat is an important safety device serving as an added protection against failure of the airflow sail switch to open in the event of a motor failure or reduced air flow condition.

**IMPORTANT:** Under no circumstances should heat circuit safety devices ever be disabled.

1. Discontinue power to dryer.
2. Remove the Two (2) hex head screws from the Hi-Limit switch. The two lock washers and the Hi-Limit will be removed from the burner box. Remove the two (2) wires from the Hi-Limit
3. Reverse procedure for installing new thermostat.

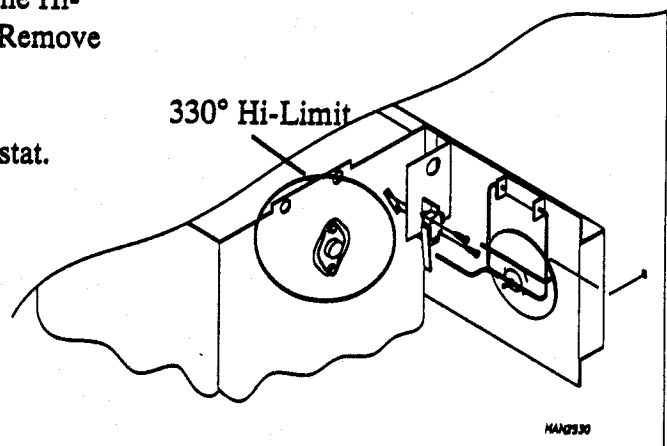

## **TO REMOVE THE TEMPERATURE SENSOR OR HIGH HEAT PROTECTOR**

### **A. HIGH HEAT PROTECTOR**

1. Discontinue power to dryer
2. Remove the lint drawer from the dryer.
3. Remove the 2 free spin wash nuts that is securing the temperature sensor bracket to the dryer.
4. Disconnect the 4 pin connector on that temperature sensor bracket.

**NOTE:** Be careful not to let the sensor harness that you just disconnected to fall back into the computer area.

5. Remove the two (2) nuts, washers, and screws securing the 225° Hi-Limit to the sensor bracket also disconnect the 2 connectors on the 225° Hi-Limit.
6. Reverse the procedure for installation of new high heat protector.

### **B. TEMPERATURE SENSOR**

1. Discontinue power to dryer.
2. Remove the lint draw from the dryer.
3. Remove the two (2) free spin wash nuts that is securing the temperature sensor bracket to the dryer.
4. Disconnect the 4-pin connector on that temperature sensor bracket.

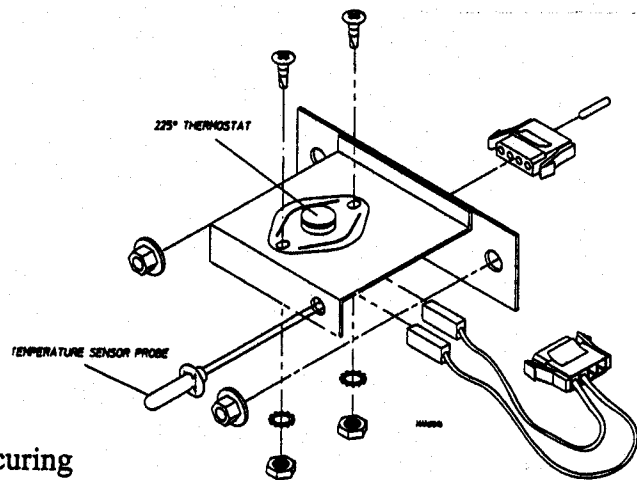

**NOTE:** Be careful not to let the sensor harness that you just disconnected to fall back into the computer area.

5. Remove the top tinnerman clip that secures the sensor probe to the bracket also remove the connector from the bracket . Disconnect the 2 wires going to the 225° Hi-Limit. The sensor probe assembly can now be removed from the bracket.
6. Install new probe assembly (ADC P/N: 880251) by reversing procedure.



## G. SAIL SWITCH ASSEMBLY

The sail switch is a heat circuit safety device which controls the heat circuit only. When the dryer is operating and there is proper air flow the sail switch damper pulls in and closes the sail switch. Providing all the other heat-related circuits are functioning properly. If an improper air flow occurs, the sail switch damper will release, and the circuit will open.

**IMPORTANT:** Under no circumstances should heat circuit safety devices ever be disabled.

### TO REPLACE SAIL SWITCH

1. Discontinue power to the dryer.
2. Remove the two (2) screws which hold the sail switch to the bracket.

**NOTE:** Be careful not to drop or loose the twin speed nut on the backside of the sail switch

3. Disconnect the two (2) connectors on the sail switch.
4. Reverse this procedure for installing new sail switch.  
Adjust sail switch as described in the next section.

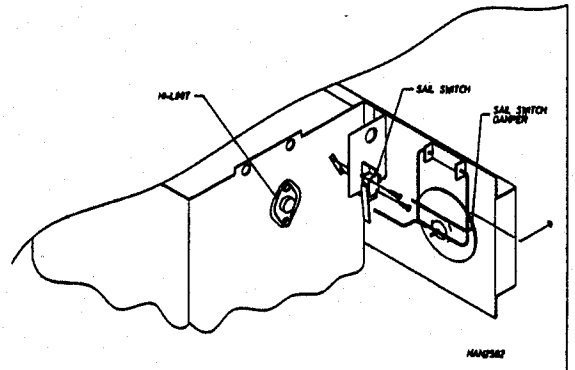

### TO ADJUST SAIL SWITCH

1. Operate the installed dryer normally to verify that the heat system is fully operational.
2. Open the main dryer door.
3. Manually depress the door switch actuator.
4. While continuing to depress the door switch actuator, and with the door open, start the dryer.
5. If the heat system is not activated in 15 seconds, the sail switch is properly adjusted.
6. If the heat system is activated, the sail switch is improperly adjusted and must be readjusted by bending the actuator arm of the sail switch toward the left side of the dryer. If the actuator arm is bent too far toward the left side of the dryer, the dryer may not have heat when needed. After any adjustments of the sail switch, the above procedure must be repeated to verify proper operation.

**CAUTION:** Do not disable this switch by taping or screwing sail switch damper to burner.  
Personal injury or fire could result.

## H. FRONT PANEL AND MAIN DOOR ASSEMBLIES

### TO REPLACE MAIN DOOR SWITCH (PLASTIC DOOR)

1. Discontinue power to dryer.
2. Open main door.
3. Remove the two (2) Phillips head screws holding the main door switch in place.
4. Remove door switch bracket and disconnect wiring from switch(es).
5. Disassemble door switch bracket by removing the two (2) nuts holding the door switch in place and assemble onto new door switch.
6. Reverse this procedure for installing new door switch.

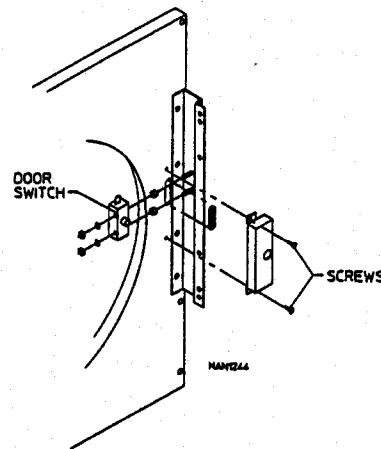

**IMPORTANT:** Under no circumstances should the door switch be disabled.

### TO REPLACE MAIN DOOR HINGE (PLASTIC DOOR)

1. Discontinue power to dryer.
2. Follow procedure for removal of main door assembly.
3. Follow procedure for removal of front panel assembly.
4. Disassemble hinge from front panel by removing the nuts located on the back side of the front panel, which hold the hinge to the front panel.

**IMPORTANT:** When removing hinge assembly from front panel be careful you do not damage main door switch

5. Remove main door switch assembly.
6. Re-assemble by reversing removal procedure.

### **TO REPLACE MAIN DOOR SWITCH (STEEL DOOR)**

1. Discontinue power to dryer.
2. Open main door.
3. Remove the two (2) Phillips head screws holding the main door switch in place.
4. Disconnect the two (2) connectors from the door switch
5. Disassemble door switch bracket by removing the two (2) nuts holding the door switch to the housing, and remove the door switch.
6. Reverse this procedure for installing new door switch.

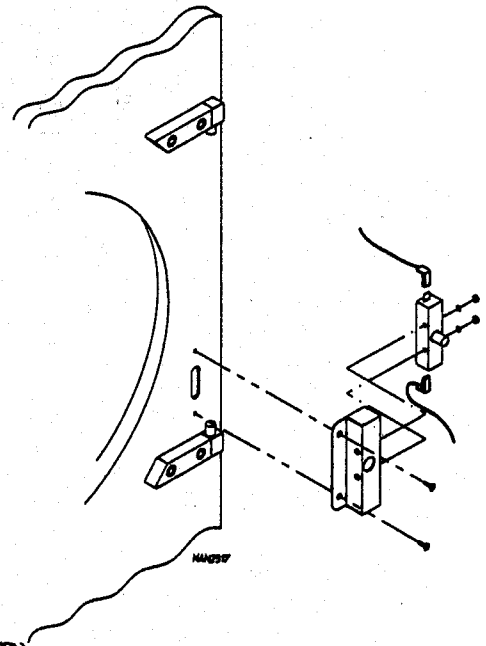

### **TO REPLACE MAIN DOOR ASSEMBLY (STEEL DOOR)**

1. Discontinue power to the dryer,
2. Remove the two (2) top 3/16" Allen screws securing the top hinge pin to the front panel.
3. Remove the door from the dryer by lifting the door off the bottom hinge pin.
4. Remove the bottom hinge pin assembly from the front panel two (2) 3/16" Allen screws securing the hinge pin to the front panel.

**NOTE:** Be careful not to lose the plastic washer on the hinge pin.

5. Re-assemble in the reverse steps.

### **TO INSTALL NEW MAIN DOOR GLASS**

1. Remove main door assembly from dryer (follow main door removal procedure).
2. Lay main door on a flat surface with front of door face down.
3. Remove glass and clean all old sealant off main door. This area must be completely cleaned for correct bonding.
4. Apply a narrow bead of silicone (ADC P/N: 170730) all around main door area where glass will rest.
5. Install glass on to door/adhesive and slightly press glass in place.

**IMPORTANT:** Do not press hard or silicone thickness between the glass and door will be reduced resulting in poor bonding.

6. The door assembly should now be put in an area where it will not be disturbed for at least 24 hours. Depending on the conditions, the curing time of the adhesive is 24 to 36 hours.
7. After 24 hour curing period, install main door on dryer by reversing step 1.

### **TO REPLACE FRONT PANEL**

1. Discontinue power to dryer.
2. Follow procedure for removal of main door assembly (Plastic or steel).
3. Follow procedure for removal of main door switch assembly (Plastic or steel).
4. Remove lint screen drawers from the dryer.
5. Remove the screws securing the front panel to the dryer.
6. Disconnect the 4-pin door switch harness connector from the lint drawer switch box..
7. Remove the front panel assembly from dryer.
8. Reverse this procedure for installing new front panel.

### **TO REPLACE THE NYLON CATCH**

1. Open main door.
2. Drill out the (2) pop rivets holding nylon catch to front panel using #21 (.1590) drill bit.
3. Using two (2) pop rivets (part number 154215) install nylon catch (part number 170330) to front panel.

# I. TUMBLER AND BEARING ASSEMBLY

(Remove back guard to access assembly)

## TO REPLACE TUMBLER PULLEY

1. Disconnect power to dryer.
2. Remove back guard.
3. Loosen v-belts, then rotate pulley and roll v-belts out of grooves.
4. Loosen two (2) set screws on the pulley and pull the pulley off the shaft.
5. Reverse procedure for installing new tumbler pulley.

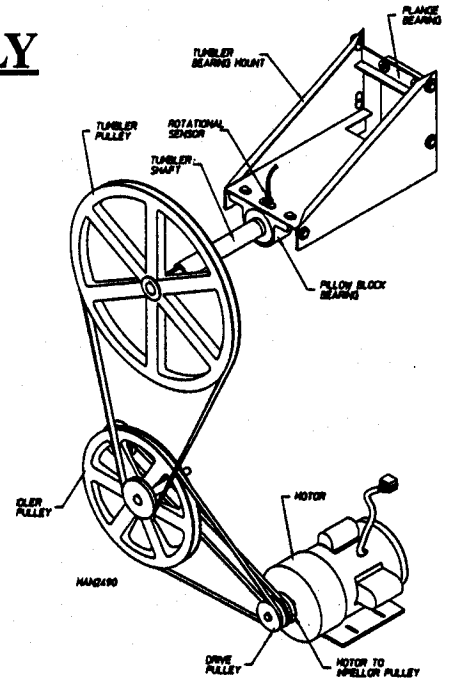

**NOTE:** Check belt alignment before operating dryer.

## TO REPLACE THE REAR TUMBLER BEARING or PILLOW BLOCK BEARING

1. Disconnect power to dryer
2. Remove tumbler pulley (follow tumbler pulley removal procedure).
3. Remove the two (2) nuts, lock washers and flat washers that hold the pillow-block bearing to the tumbler support mount.
4. Take note of the position of the two (2) side adjusting bolts on the side of the bearing mount assembly. Loosen these two (2) bolts enough to slide the pillow-block bearing off the shaft.
5. Loosen the two (2) 5/16" set screws on the pillow-block bearing.
6. Slide the bearing off of the shaft.

**NOTE:** If any rust has developed, use an emery cloth to polish the shaft.

7. Install new bearing in reverse procedure.

**NOTE:** Check the alignment of tumbler to make sure the basket is not hitting the sides, the top or the bottom of the basket. While the set screws are loose check front to back alignment of the basket. Make sure set screws are tight when alignment is finished.

**NOTE:** Check alignment of pulleys before operating dryer.

### **TO REPLACE THE FRONT TUMBLER BEARING or FLANGE BEARING**

1. Discontinue power to dryer
2. Remove backguard
3. Remove the front panel (follow to replace front panel).
4. Remove tumbler pulley by loosening the two (2) set screws (5/16") screws in the pulley.
5. Loosen the two (2) set screws located both in the flange bearing and in the pillow block bearing.
6. Remove the basket and support assembly (follow to replace the tumbler and/or tumbler support).

**NOTE:** If any rust has developed, use an emery cloth to polish the shaft.

7. Remove the pillow block bearing by loosening the two (2) bolts securing the pillow block bearing to the bearing box.
8. Remove the flange bearing by loosening the four (4) nuts securing the bearing to the back of the dryer.
9. Reverse procedure for installing new tumbler bearings.
10. Replace backguard and reestablish power to the dryer.

**NOTE:** Check the alignment of tumbler to make sure basket not hitting the sides or the top or the bottom of the basket. While the set screws are loose check front to back alignment of the of the basket. Make sure set screws are tight when alignment is finished.

## **J. IDLER & BEARING ASSEMBLY**

(Remove back guard to access assembly)

### **TO REPLACE IDLER PULLEY**

1. Discontinue power to the dryer
2. Remove back guard.
2. Loosen v-belts, then rotate pulley and roll v-belts out of grooves.
4. Loosen the two (2) set screws on the pulley and pull off the shaft.
5. Reverse procedure for installing new idler pulley.

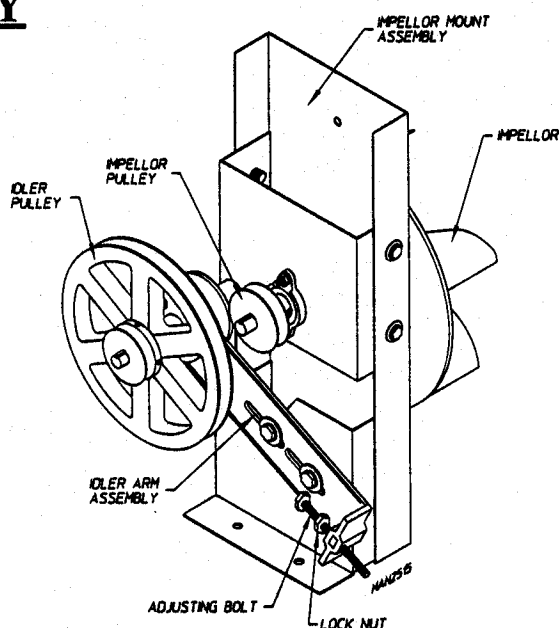

**NOTE:** Check tension and alignment of belts before operating dryer.

**NOTE:** The idler shaft is pressed onto the bearings. If this is not done properly component failure could result. ADC recommends that the whole idler assembly be replaced (ADC P/N: 801008).

### **TO REPLACE IDLER BEARING**

1. Remove idler pulley (follow "TO REPLACE IDLER PULLEY")
2. Remove idler arm.
  - A. Remove two (2) bolts securing idler arm to the idler backup plate.
  - B. Remove idler arm assembly.
  - C. Loosen set screws on both the front and rear bearing and remove the idler shaft.
  - D. Remove 3 bolts securing the bearing to the idler arm and remove bearings.
3. Reverse procedure for installing new idler bearings.

**NOTE:** Check tension and alignment of belts before operating dryer.

### **K. DRIVE PULLEY**

(Remove back guard to access assembly)

1. Remove back guard.
2. Loosen idler arm assembly then rotate pulley and roll v-belts out of groove.
3. Loosen the set screw of both pulleys if you are changing the pulley closer to the motor, or just the set screw of the first pulley if you are changing the first pulley. Then slide the pulley off the motor shaft

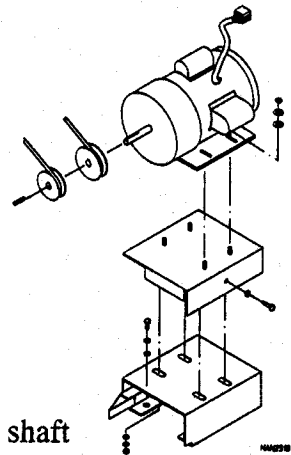

**NOTE:** If rust has developed on the shaft use an emery cloth to polish the shaft.

**NOTE:** Check tension and alignment of belts before operating dryer.

## **L. TUMBLER (BASKET)**

### **TUMBLER ALIGNMENT (VERTICAL)**

1. Discontinue power to dryer.
2. Remove back guard.
3. Loosen the four (4) hex head bolts on the sides of the tumbler bearing mount.
4. Back off jam nuts on the two (2) Allen head adjustment screws.
5. Turn the screws clockwise evenly to raise the tumbler or counterclockwise evenly to lower the tumbler.
6. Rotate the tumbler from the front and check alignment with the main door opening.
7. Leave a large gap from the inside ring on the top of the front panel opening to the tumbler, and a smaller gap on the bottom to compensate for the weight of the clothes drying.
8. Tighten the four (4) hex head bolts on the sides of the tumbler bearing mount, and the two (2) locking nuts located on the allen head adjustment screws.
9. Replace back guard.
10. Reconnect power to dryer.

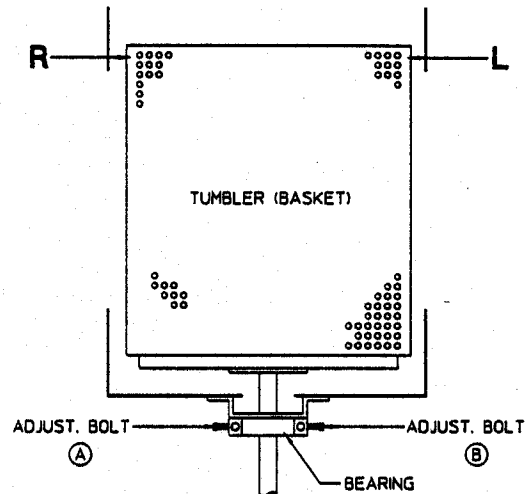
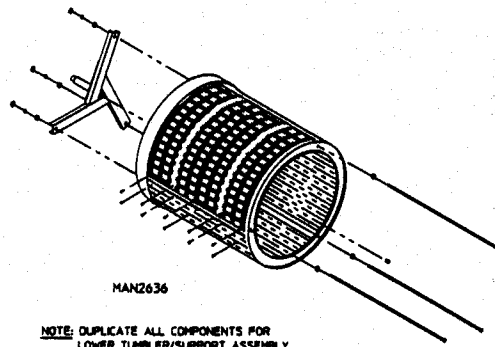

### **REAR OF DRYER**

### **TUMBLER ALIGNMENT (LATERAL)**

1. Discontinue power to the dryer.
2. Remove back guard.
3. Loosen the two (2) hex head bolts, (one turn is enough), that holds the pillow block bearing to the bearing box.
4. Back off the two (2) jam nuts on the side adjustment bolts. Now rotate the tumbler from the front of the dryer, checking the space between the tumbler and the front panel. This should be equal on the left hand and right hand side.



5. Lateral adjustment (viewing from the rear)

- A. Loosening (by turning counterclockwise) the left hand adjustment bolt and tightening (by turning clockwise) the right hand adjustment bolt will shift the basket to the right.
- B. Loosening (by turning counterclockwise) the right hand adjustment bolt and tightening (by turning clockwise) the left hand adjustment bolt will shift the basket to the left.

6. Tighten and secure both adjustment bolts and jam nuts.

7. Tighten the bearing box bolts.

8. Replace back guard and re-establish power to the dryer.

### **TO REPLACE THE TUMBLER AND/OR TUMBLER SUPPORT**

1. Remove the tumbler pulley, and tumbler bearing mount (follow "TO REPLACE THE REAR TUMBLER BEARING" steps 1 through 6).
2. Remove front panel assembly (follow "TO REPLACE FRONT PANEL ASSEMBLY").
3. Loosen set screws on front tumbler bearing.
4. Using a wheel puller gently push the tumbler shaft towards the front through the front tumbler bearing.

**NOTE:** An alternate method would be to place a block of wood on the end of the tumbler shaft and strike it with a heavy hammer. To prevent damage to the shaft, the wheel puller method is preferred.

5. Remove the tumbler and support through the front of the dryer.

A. Remove the bolt in the center of the tumbler back wall.

B. Loosen and remove the nuts and washers from the tumbler tie rods. Remove the rods.

C. Replace either tumbler or tumbler support by reversing the procedure.

6. Reassemble components into dryer by reversing steps 1 through 4.

7. Check tumbler lateral and vertical alignment. Also, check belt tension and alignment.

**NOTE:** Check tension of belts and alignment of tumbler before operating dryer.

8. Replace back guard and re-establish power to dryer.

## **M. V-BELTS**

V-Belts should have proper tension. If too loose, they will slip, if too tight excessive wear on the bearing will result. If the pulleys are not properly aligned, excessive belt wear will result. Proper belt tension will allow 1/2" displacement under normal thumb pressure at mid span of the belt.

**NOTE:** The motor to impellor adjustment must be performed first before the other two (motor to idler, and idler to tumbler van be performed).

### **V-BELT TENSION ADJUSTMENT-TUMBLER TO IDLER**

1. Discontinue power to the dryer.
2. Loosen the two (2) bolts on the idler arm.
3. Back off jam nut on the adjustment bolt.
4. Tighten belts by turning adjustment bolt clockwise.  
(Turn counterclockwise to loosen belts)
5. Tighten both bolts connecting to back-up plate.
6. Check vertical plane of idler pulley for parallel alignment with tumbler pulley.
7. If realignment is required, loosen tumbler pulley and move tumbler pulley to proper position
8. Re-tighten jam nut.

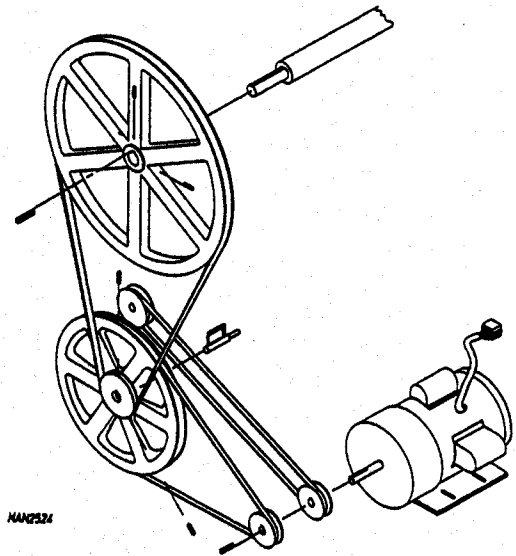

### **V-BELT TENSION ALIGNMENT - MOTOR TO IDLER**

1. Discontinue power to dryer.
2. Loosen the four (4) nuts underneath the motor mount slide plate.
3. Loosen the lock nut on the adjusting bolt located on the side of the motor mount slide.
4. Adjust the tension of the motor to impellor pulley belt by tightening that adjusting bolt to tighten the belt or loosening the bolt to loosen the belt.

5. Once the proper tension of the motor to impellor belt has been achieved, tighten the four (4) nuts, loosened in step 2.
6. Tighten the locking nut of the adjusting bolt.

### **TO REPLACE V-BELTS**

1. Loosen tension on V-Belts going to the idler arm assembly, so that they can easily be rolled off pulleys.
2. Replace V-Belts.
3. Re-tighten V-Belts and adjust tension alignment per previous instructions.

## **N. MOTOR**

### **TO REPLACE MOTOR**

1. Discontinue power to dryer.
2. Remove the two (2) belts from the dual motor pulleys.
3. Disconnect wiring harness from motor.
4. Remove the four (4) nuts, flat washers, lock washers securing the upper half of the split motor mount assembly to the lower half of the motor mount assembly and remove the motor from the dryer.
5. Remove the motor pulleys from the existing motor shaft and transfer to the new motor.
6. Remove the four (4) nuts, lock washers, and flat washers securing the motor to the upper half of the motor mount assembly.
7. Re-assemble in the reverse of the above.

## **O. REPLACING THE IMPELLOR MOUNT ASSEMBLY**

(See illustration on next page)

1. Discontinue power to dryer.
2. Loosen and remove the two (2) bolts holding the idler arm assembly to the impellor mount plate.
3. Remove the idler arm assembly and the belts from the dryer.

4. Remove the two (2) bolts, lock washers, and flat washers securing the bottom of the impellor mount to the machine.
5. Remove the one nut, lock washer, and flat washer from the top of the impellor mount.
6. Remove the impellor mount assembly from the dryer.
7. Remove the two nuts and washers from the end of the impellor shaft.
8. Work the impellor free from the shaft by means of either pulling evenly on the impellor or a puller, be careful not to damage the end of the impellor shaft.
9. Re-assemble by means of the above procedure.

**NOTE: BE SURE TO CHECK TENSION AND ALIGNMENT OF THE FAN AND THE IDLER BELTS WHEN REPLACING THE FAN MOUNT ASSEMBLY IF NEED BE READ THE BELTS SECTION IN THIS MANUAL.**

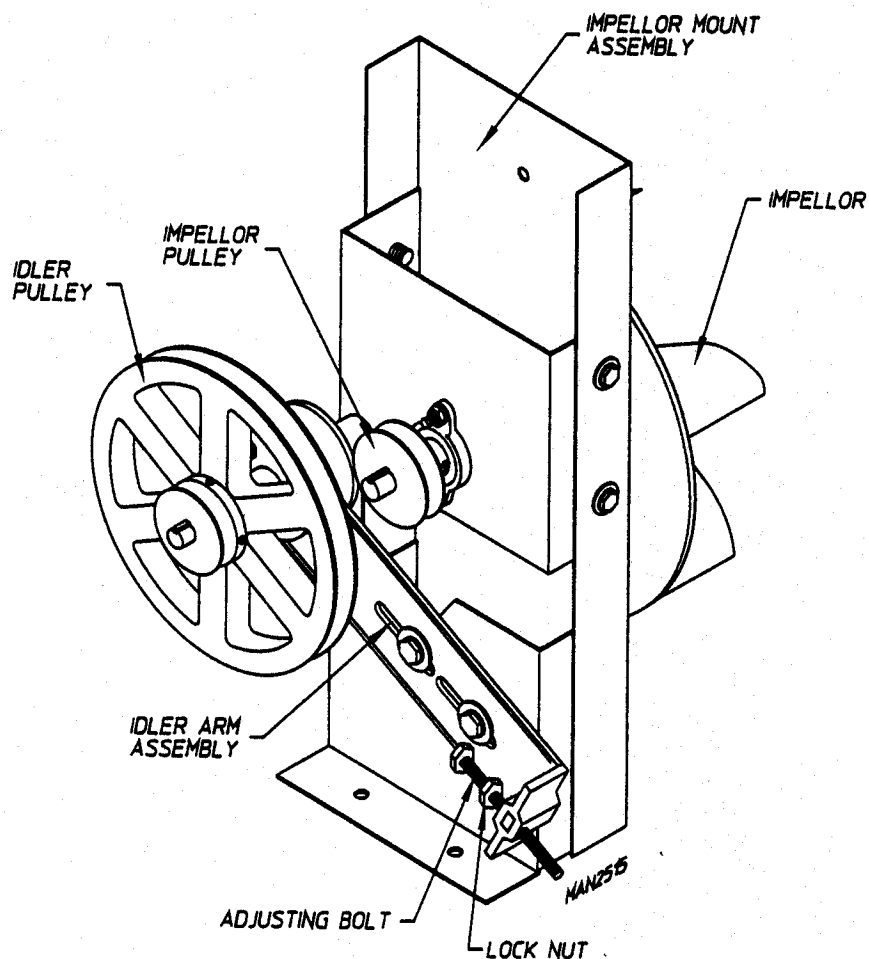

# SECTION VI

## TROUBLE SHOOTING

The information provided will help isolate the most probable components associated with the difficulty described. The experienced technician realizes, however, that a loose connection or broken or shorted wire may be at fault where electrical components are concerned.... not necessarily the suspected component itself.

**Electrical parts should always be checked for failure before returned to the factory.**

The information provided should not be construed as a device for use by an untrained person in making repairs. Only properly licensed technicians should service the equipment.

**Observe all safety precautions displaced on the equipment or specified in this manual while making repairs.**

### A. PHASE 5 COIN SYSTEM DIAGNOSTICS

All major circuits, including door, microprocessor temperature sensor, heat and motor circuits are monitored. The Phase 5 coin microprocessor controller will inform the user by the LED display of certain failure codes along with indicators both in the LED display at the outputs of each relay and door switch circuit to easily identify failures.

#### DIAGNOSTICS (LED DISPLAY) FAILURE CODES

1. "dOOr" - indicates door switch circuit is open.
  - a. Keyboard entry was made while main door is open, or
  - b. There is a fault in the door switch circuit (external of the microprocessor controller)
2. "dSFL" - indicates a fault in the microprocessor temperature sensor circuit. If a fault is detected in the microprocessor heat sensor circuit, the display will read "dSFL." and the tone (buzzer) will sound for approximately 5 seconds every 30 seconds until...
  - a. The problem is corrected, or
  - b. Power to the dryer is disconnected and the problem is then corrected.

**IMPORTANT:** The Phase 5 coin microprocessor controller has its own internal heat sensing circuit fuse protection located on the back side of the controller. If a "dSFL" condition occurs, check to see if this fuse has blown. If it has. **DO NOT** replace the entire microprocessor controller; replace the fuse and do so with a 1/8-Amp (Slo Blo) fuse **ONLY**.

**NOTE:** Once the microprocessor controller detects a problem in the heat circuit, it updates every 30 seconds. If the problem was a loose connection in this circuit which corrected itself, the "dSFL" condition would be cancelled.

3. **"SEFL"** -indicates rotational sensor circuit failure meaning that there is a fault somewhere in the basket (tumbler) rotation detection circuit, or the Phase 5 coin microprocessor controller program related to this circuit (PL01) is set incorrectly in the active mode (SEn) where the dryer is not equipped with the optional rotational sensor and should be set in the non-active mode (nSEn).
4. **"Hot"** -indicates a possible overheating condition. The Phase 5 coin microprocessor controller monitors the temperature in the dryer at all times. If the microprocessor controller detects that the temperature in the dryer has exceeded 220° F (104°C), it will disable all outputs (shut the dryer down), the tone (bUZ) will sound for approximately 5 seconds, and the LED temperature sensor has dropped to 220° F or lower and the microprocessor controller is manually reset by closing and opening the program switch (PS) on the back side of the controller.

### **MICROPROCESSOR CONTROLLER RELAY OUTPUT L.E.D. INDICATORS**

There are three (3) LED indicators (red lights) located at the lower backside area of the controller are identified/labeled "DOOR," "MTR." and "HEAT" (as shown in the illustration on the next page). These LED's indicate that the outputs of the Phase 5 coin microprocessor controller or, in the case of the door switch, the input is functioning.

1. **"DOOR"** LED indicator should be on all the time (even if the dryer is not running) unless the main door is open or there is a problem (open circuit) in the main door switch circuit.
2. **"MOTOR"** Output L.E.D. Indicator - if the dryer is started and the motor is not operating, yet both the microprocessor controller display motor indicator dot and the "dOOr" input L.E.D. indicator are on, but the motor output LED indicator is off, then the fault is in the Phase 5 coin microprocessor controller itself. If the motor is not operating and the MOTOR output indicator is on, then the problem is elsewhere (i.e., external of the microprocessor controller).
3. **"HEAT"** Output LED Indicator - If the dryer is started and there is no "heat." Yet the microprocessor controller display heat circuit indicator dot is on, but the output LED indicator is off, then the fault is in the Phase 5 coin microprocessor controller itself. If both the display heat indicator dot and the heat output LED indicator are on, then the problem is elsewhere (i.e., external of the microprocessor controller).

**NOTE:** If the dryer is started (the LED display indicator dots are on) and there are no outputs (heat and/or motor output LED's are off) and the "dOOr" input LED is on, the fault is in the Phase 5 microprocessor controller itself. If the LED display indicators are on and the door LED input and motor/heat output LED's are on the motor and/or heat is not active (on), then the problem is not the door switch circuit or the Phase 5 coin microprocessor controller; the problem is elsewhere in the dryer.

## L.E.D. DISPLAY INDICATORS

The LED indicator dots located at the top portion of the LED display (as shown in the illustration below) indicate the Phase 5 coin microprocessor controller output functions while a cycle is in progress. These dots do not necessarily mean that the outputs are functioning. They are only indicating that the function (output) should be active (on).

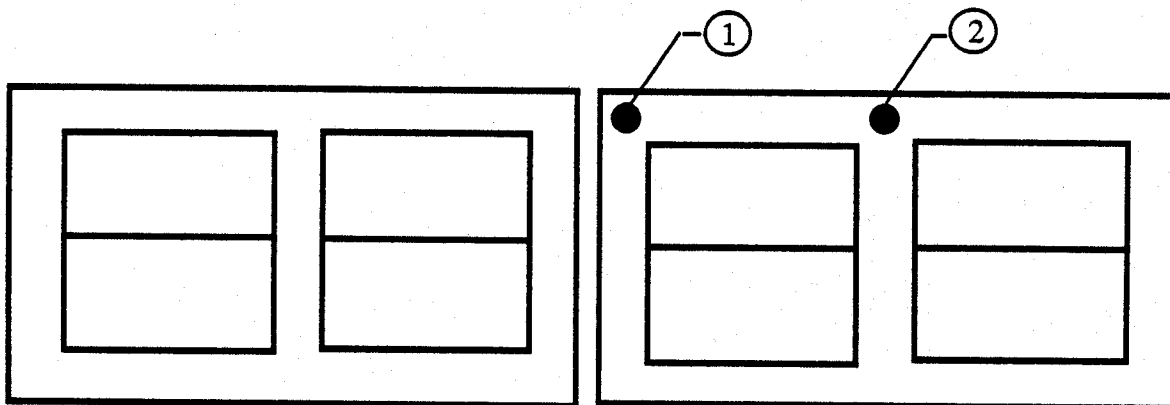

1. Heat Circuit Indicator - indicator dot is on whenever the Phase 5 coin microprocessor controller is calling for the heating circuit to be active (ON).
2. Motor Circuit Indicator - indicator dot is on whenever a cycle is in progress.

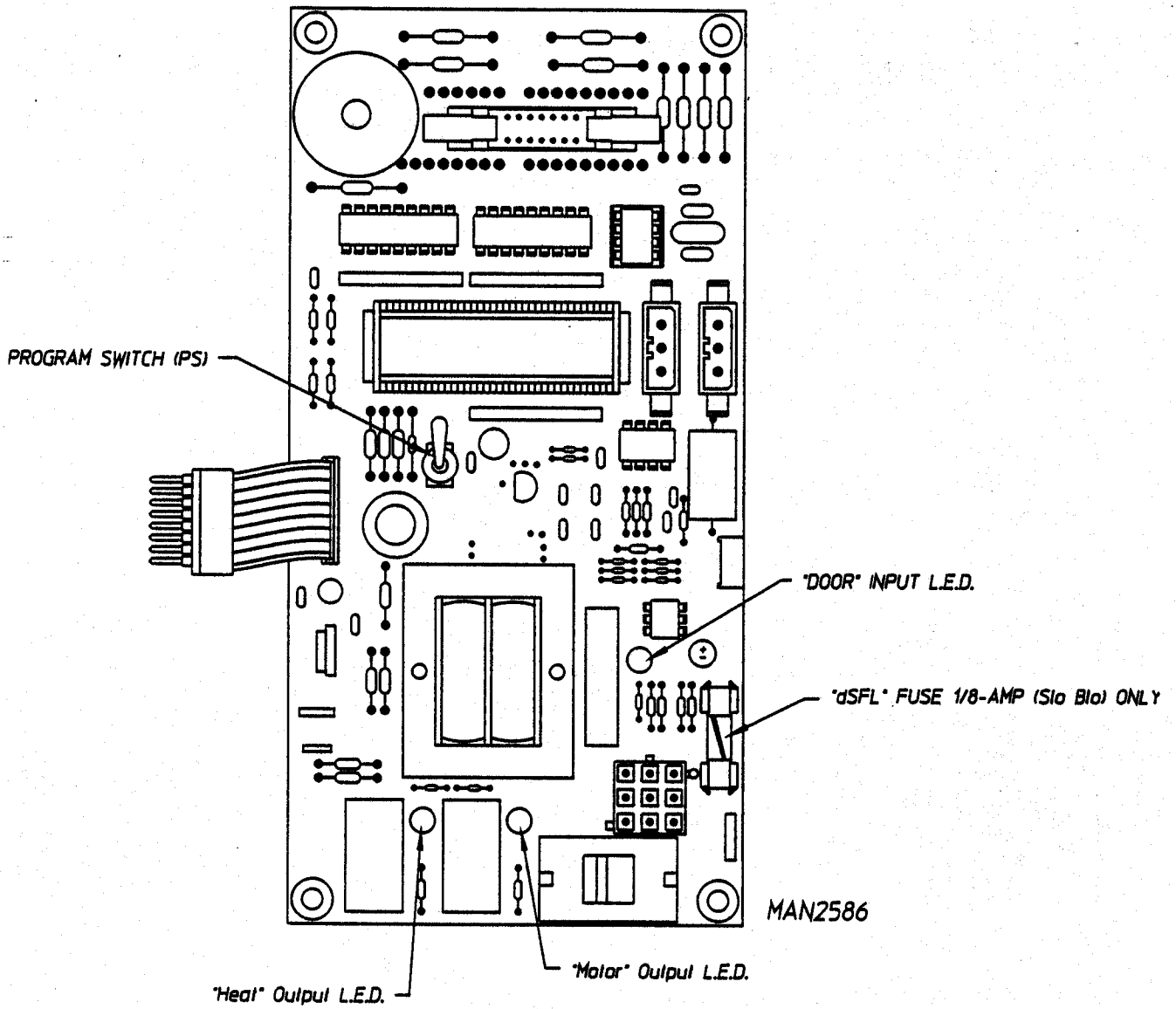



## B. NO HEAT CONDITION (Gas Models)

The following procedure must be performed with the microprocessor controller display in the normal operating mode, the heat indicator dot on, and the LED heat output light is on. Voltage is 24 VAC unless otherwise specified.

1. Check to see if DSI module fault indicator LED is on or flashing. If yes, refer to "DSI" Trouble Shooting Booklet. (P/N: 450142)

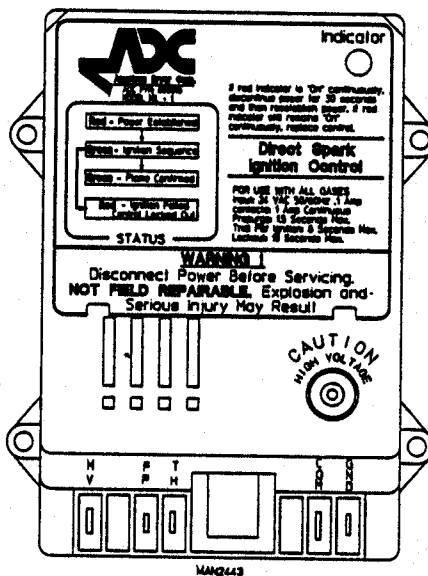

2. Check for voltage (approximately 25VAC) across DSI module terminals "STAT" or "TH" and "GND." If voltage is evident, refer to "DSI" trouble Shooting Booklet. (P/N: 450142) If no voltage continue on with step # 3.

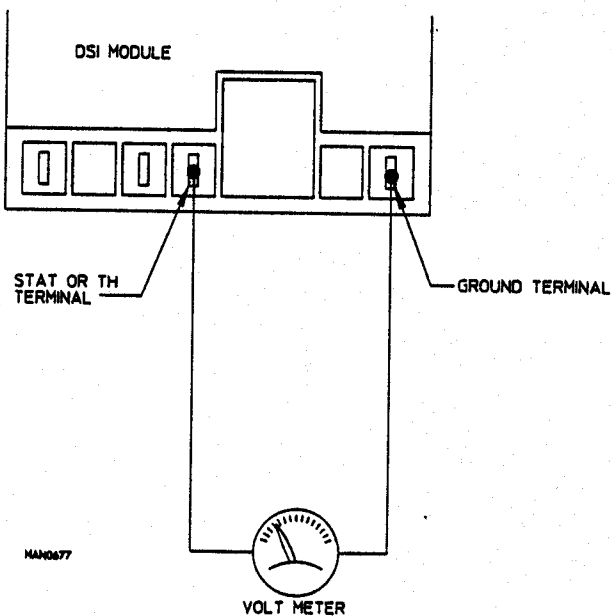

**NOTE:** Make sure the sail switch damper is closing properly. If so, check to see if it is making contact with the switch. If the sail switch damper is not closing properly check for exhaust restriction, or exhaust damper restriction and / or clogged lint screen.

3. Check for voltage between pin #1 & 3 of the 3 pin connector located in the relay box (back of dryer). If voltage is evident, problem is break in wire or termination between pin # 1 and the DSI module "STAT", "TH", or "Gnd" terminal. If no voltage continue on with step #4.

### 3 PIN CONNECTOR

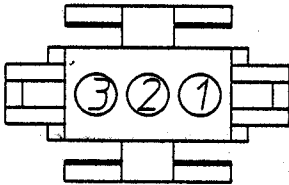

MAN2510

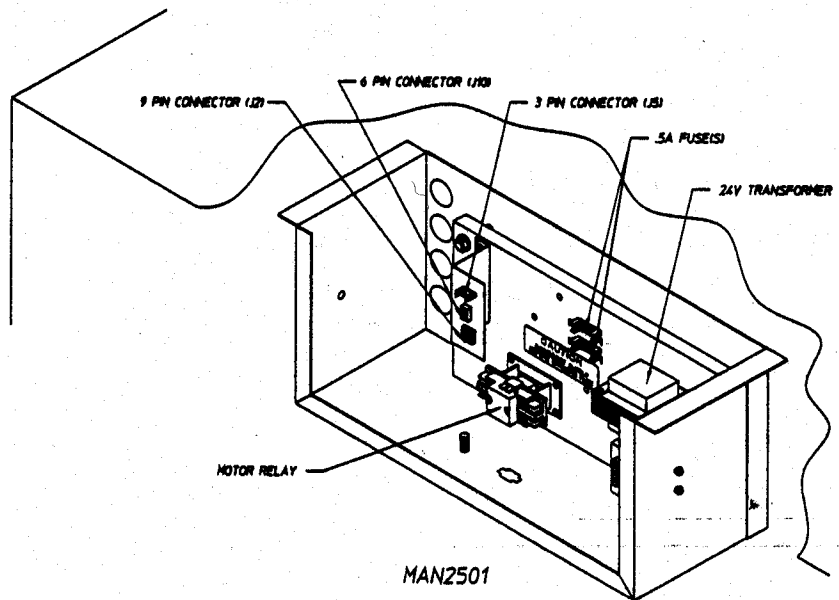

MAN2501

**NOTE:** Check to make sure that the jumper wire has a good connection. (Pin # 1 & 2 of the 3 pin connector J5).

4. Check for voltage across the 9 pin connector (J2) pin # 2, and to ground. If voltage is evident, problem is defective burner hi-limit switch P/N: 130401 or the sail switch\* P/N: 122200, or the harness connecting these two devices to the 9 pin connector (J2) pin # 2 and the 3 pin connector pin # 2.. If no voltage continue on with step # 5

### 9 PIN CONNECTOR

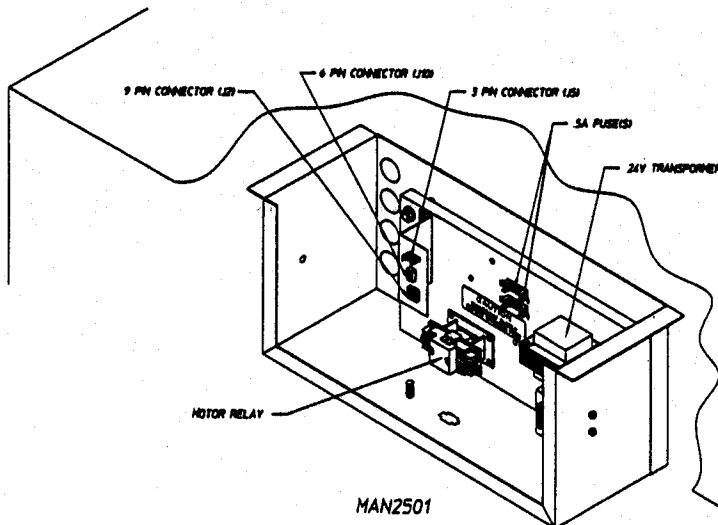

MAN2501

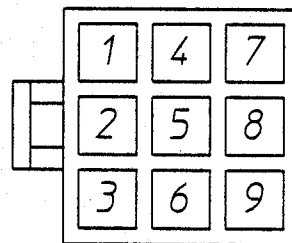

MAN2508

5. Check for voltage across the 6 pin connector (J10) pin # 6 and ground. If voltage is evident, problem is the orange wire on pin # 6 of the 6 pin connector (J10) to the 9 pin connector (J2) pin # 2 . There is a bad connection or loose termination. If no voltage continue on with step # 6.

### 6 PIN CONNECTOR

6. Check for voltage across the 6 pin connector (J3) located near the temperature sensor bracket pin # 6 and ground. If voltage problem is bad wire termination between that (J3) connector Pin # 6 and the (J10) connector pin # 6.

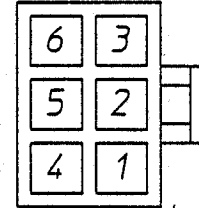

MAN2509

7. Check for voltage on the 4 pin connector (J7) of the temperature sensor bracket. Pin 3 & 4, check individually each one with respect to ground. If voltage is not on #4 but is on terminal #3 replace the hi-limit thermostat. If voltage is on both terminals the problem is a bad wire or termination between that 4 pin connector pin # 4 and the 6 pin connector (J3) pin # 6. If voltage is not at terminal #3 OR #4 then continue.

8. If voltage still is not reaching the "TH" & "GND" terminals of the ADC D.S.I. Module. The problem must be either a bad wire or termination on the (J3) connector pin # 5 or the (J10) connector pin # 5 or the (J2) connector pin # 8.

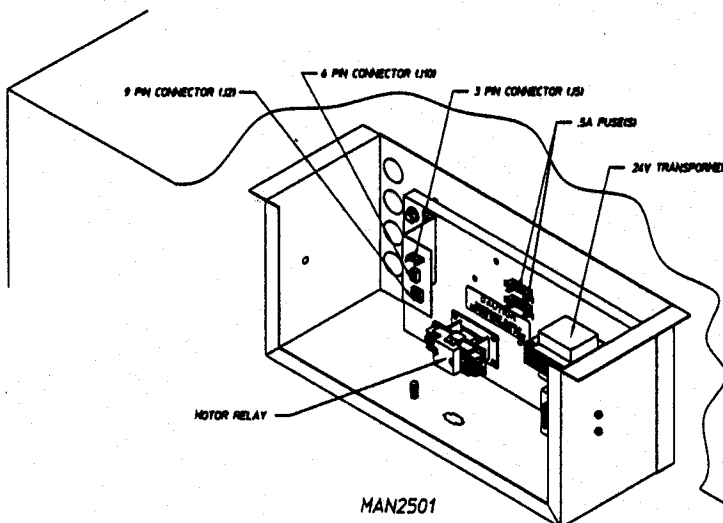

### 9 PIN CONNECTOR

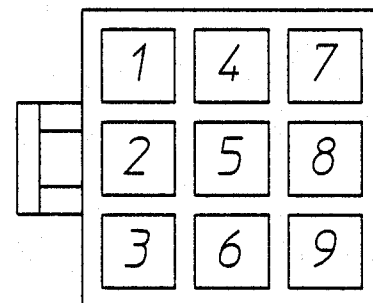

MAN2508

## 3 PIN CONNECTOR

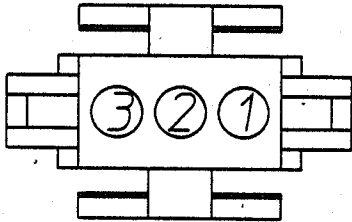

MAN2510

## 6 PIN CONNECTOR

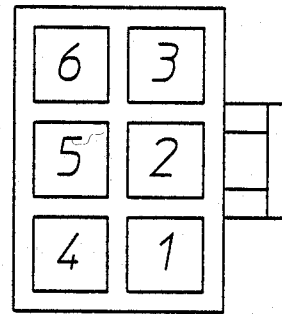

MAN2509

9. If all seems to check out OK. Check for voltage on the computer harness pin # 8 and ground, if no voltage replace computer. If voltage , go back and recheck step # 8.

## E. NO START CONDITION

Follow this test procedure, providing that the microprocessor controller is functioning where the display is in the normal operating mode and the motor indicator dot is on, and the LED motor output light is on. The voltage you should be reading is 24 VAC unless otherwise specified.

1. Check to see if "dOOr" LED input light is on. (Located on component side of the computer board.) If it's off, refer to "dOOr" in the trouble shooting section.
2. Check for voltage (115v-240v) at the motor (black & white wires going to the 8 pin plug). If voltage replace motor

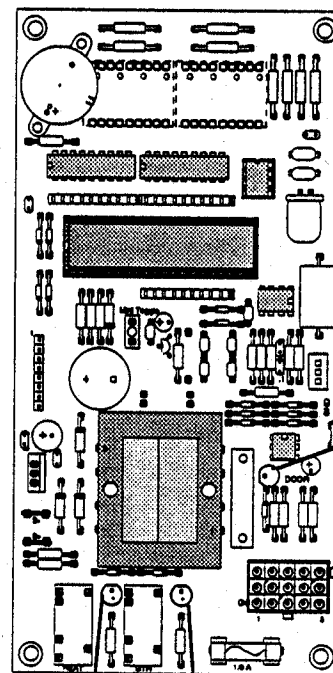

"Heat"  
Output L.E.D.

"Motor"  
Output L.E.D.

3. Check for voltage across the coil connections of the motor relay. If voltage is evident Replace the contactor

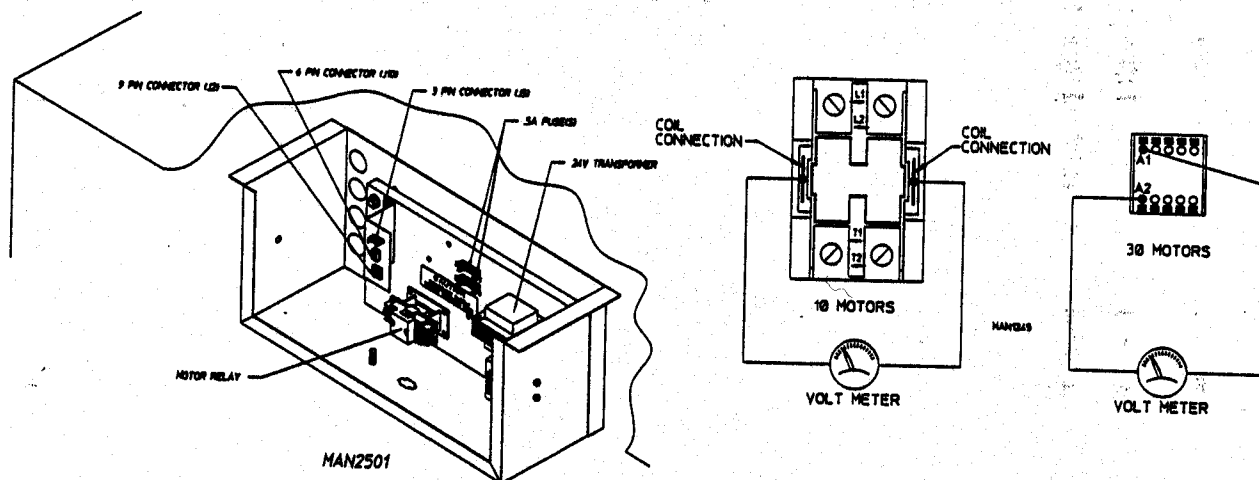

4. Check for voltage on the 9 pin connector (J2) pin # 7 to ground, if voltage problem is bad wire or termination between (J2) 9 pin connector pin # 7 and the contactor coil (blue wire).
5. Check for voltage at pin # 7 of the computer connector (blue wire) and ground. If voltage, problem is bad wire or termination between 9 pin connector (J2) pin # 7 and the computer connector pin # 7 (blue). If no voltage replace the computer.

## **F. NO DISPLAY CONDITION**

**NOTE:** Make sure the 230v/115v selector switch on the computer is on the proper position for the voltage on the dryer.

1. Check power supply. (Dryer voltage 110v, 208v, 220v ...)  
(Circuit breaker box or fuse panel)

2. Check for voltage across (L1) and (L2) of motor relay. (110v, 208v, 220v ...). If there is no voltage evident, problem is bad wire(s) or termination from the circuit breaker panel or fuse panel to the power distribution block, on L1 & L2 of motor contactor. If there is voltage continue with step # 3.

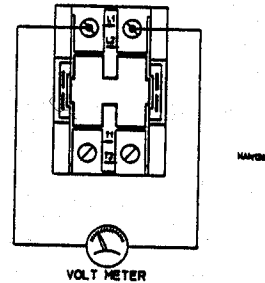

3. Check the .5 amp fuse(s) on the relay panel. If dryer is rated at 110v, 115, or 120v there will only be one fuse. Voltages of 208v, 220v will have two fuses. If blown, replaces with P/N: 136057. If not continue with step # 4.

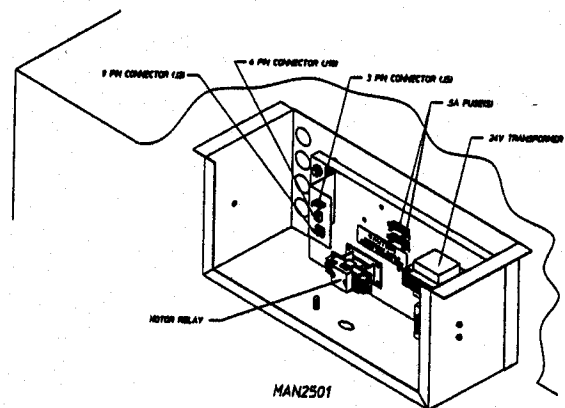

4. Check voltage across Pin # 3 & 6 of the 9 pin connector (J2) (110v, 208v, 220v). If no voltage is evident, problem is bad wire or termination from the 9 pin connector #'s 3 & 6, through the fuse(s) to the L1 & L2 connectors on the motor relay, then to the power distribution block. If there is voltage continue with step # 5.

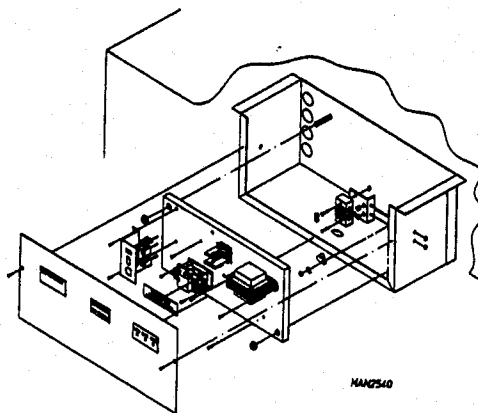

5. Check for voltage across the computer's 9 pin connector pin #6 and #3 (110v, 208v, 220v). If no voltage is evident, problem is bad wire or termination from the computer's connector pin #6 and #3 to the 9 pin connector (J2) pin's # 6 & 3. If voltage is evident, problem is faulty computer.

## G. "dSFL" DISPLAY CONDITION

When the display "dSFL" this condition indicates a fault in the microprocessor controllers heat circuit. This circuit includes the microprocessor controller, microprocessor temperature sensor (located in lint compartment) and wires to and from these two (2) points.

1. Check the 1/8 amp fuse on the computer board. If no continuity replace with ADC P/N: 136048. If fuse repeatedly burns out go to step 4.
2. Check for loose connection at the microprocessor sensor bracket harness connector (located in lint compartment), and the microprocessor 9 position connector at the microprocessor controller.

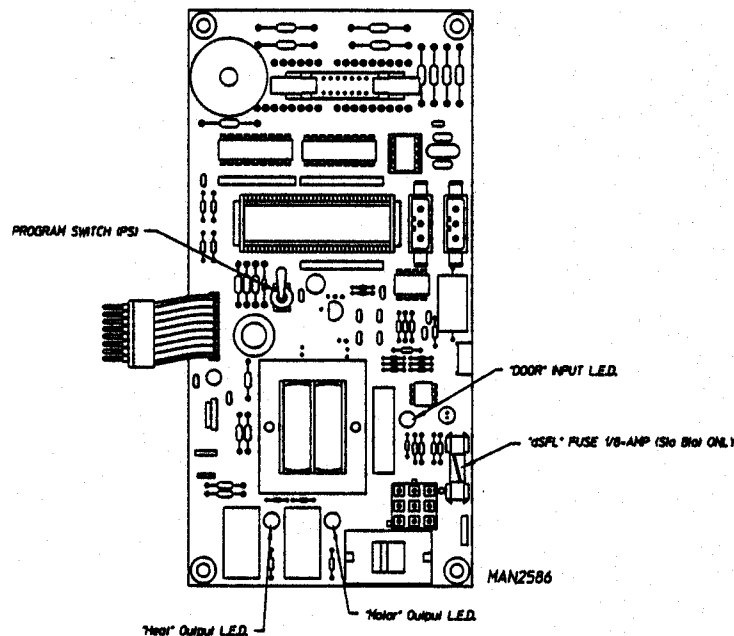

3. Discontinue power to dryer. Disconnect the microprocessor 9 position connector from microprocessor controller and locate connector holes no. 1 and 4. Disconnect sensor harness from sensor bracket assembly (located in the lint compartment). Check for continuity across each wire from harness connector in lint compartment (J7) (pin #'s 1 & 2) to appropriate microprocessor 9 position connector (1 and 4). If no continuity, problem is break in wire or bad termination from that 4 pin (J7) connector through the (J3) and (J10) 6 pin connectors, pins # 3 & 4 then through the (J2) 9 pin connector pins # 1 & 4, or then finally to the computer 9 position connector pins 1 & 4.

4. If above procedures check out okay, problem is a defective microprocessor temperature sensor.

## H. "dOOr" DISPLAY CONDITION

When the display reads "dOOr", this indicates that there is a fault (open circuit) somewhere in the microprocessor controller's door switch circuit. Include the door switch, microprocessor controller and the wires to end from these two points. Before following this test procedure, check the component side of the computer to see if LED input light is on. If on and still reads door replace computer. Voltage is 24VAC unless otherwise specified.

1. Remove door switch assembly from dryer. Check for continuity across the two terminals of the door switch with plunger pushed in. If no continuity, replace the door switch. If continuity is evident, reassemble door switch back on dryer.

a.) Repeat the above procedure; for the lint door switch.

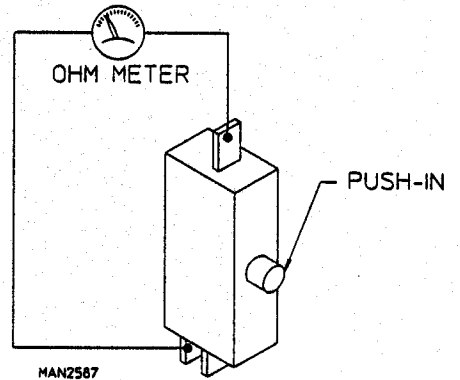

2. Make sure both the main and lint doors are closed and the plungers are pushed in. Check for voltage across pin #2 of the 6 pin connector (J10) and ground. If no voltage is evident, problem could be faulty transformer (P/N: 141403). If voltage is evident then continue with step #3.
3. Check for voltage on pin # 2 of the 6 pin connector (J3) located near the temperature sensor bracket assembly and the ground. If no voltage problem is a bad wire or termination between the (J10 & J3) connectors (pin # 2).
4. Check for voltage on the two (2) four pin connectors (J8, J9) of the lint switch assembly & ground..

### 6 PIN CONNECTOR

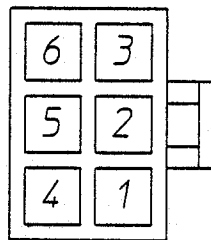

MAN2509



**NOTE: Each connector has 2 connections on them (pin #'s 2 & 4)**

- A) If voltage is not present on all 4 pins of those two connectors (J8,J9) the problem is a bad wire or termination on the main door switch or the lint drawer switch or any wires associated with these devices.
5. Check for voltage on pin # 1 of the 6 pin connector (J3) and ground, also check for voltage across pin # 1 of the 6 pin connector (J10) with respect to ground. If no voltage, problem is bad wire or termination between the (J10) and the (J3) connectors pin # 1.
  6. Check for voltage on pin # 9 of the 9 pin connector (J2) and ground.. If no voltage, problem is bad wire or termination between the (J2) pin # 9 and the (J10) pin # 1.

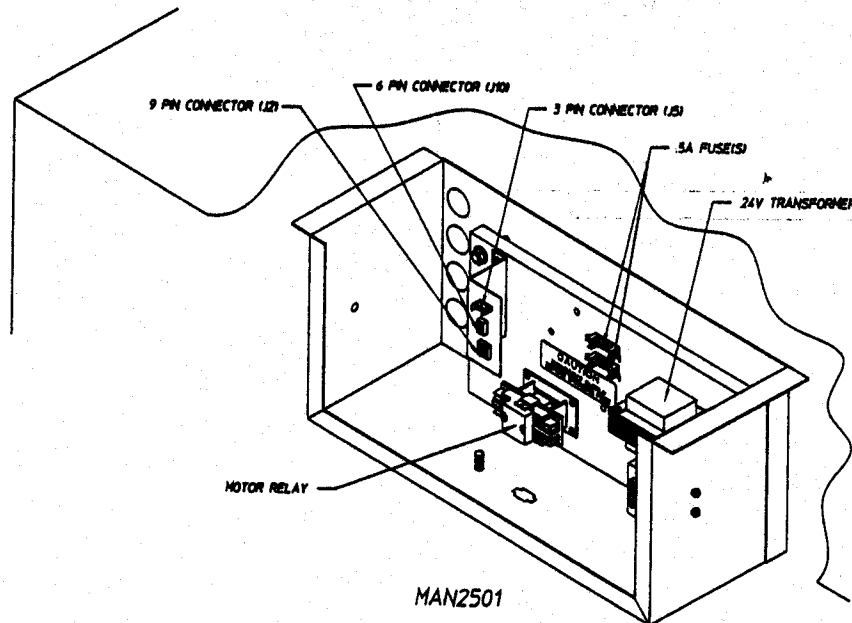

7. Check for voltage on the computers 9 pin connector, pin # 9 and ground. If no voltage, problem is bad wire or termination between the computers 9 pin connector, pin # 9 and the (J2) connector , pin #9. If voltage replace computer.

# SECTION VII

## TECHNICAL INFORMATION

### A. DATA LABEL

Contact American Dryer Corporation

<b>MODEL</b> ADG-530	<b>SERIAL NO.</b> 345947 KD
<b>MANUFACTURING CODE NUMBER</b> 6305147130317010840X00000000000000	
204,000 BTU MAX	
<b>TYPE OF HEAT</b> GAS/NATURAL	<b>HEAT INPUT</b> 102,000 BTUH PER POCKET
<b>ELECTRIC SERVICE</b> (2) 115V/60HZ/1PH 6 AMPS PER POCKET	
<b>GAS MANIFOLD PRESSURE</b> 3.5 IN WC	
<b>FOR USE WITH NATURAL AND L.P. GASES</b> 'NRTL'	
ANS Z215.2	b-1992 CLOTHES DRYER VOL II
24 VOLT CONTROL VOLTAGE	

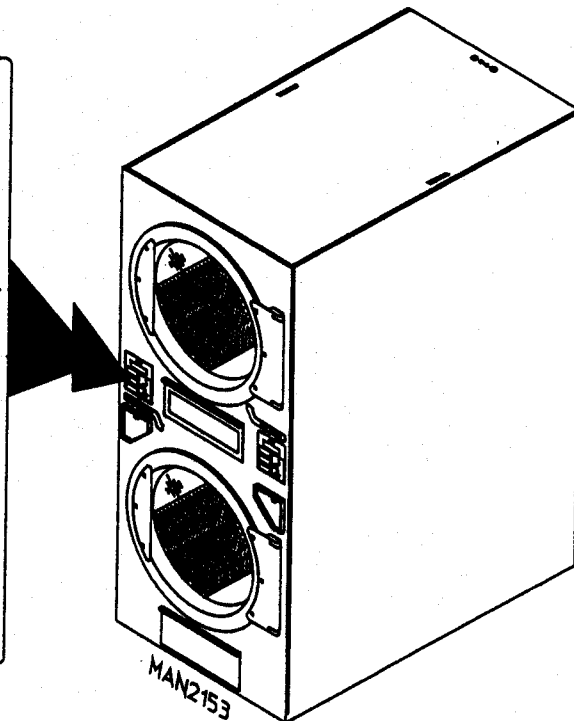

When contacting American Dryer Corporation certain information is required to insure proper service/parts information from American Dryer. This information is on the data label located on the control door. When contacting American Dryer please have the model number and serial number handy.

#### DATA LABEL

1. **MODEL NUMBER**— The model number is an ADC number which describes the size of the dryer and the type of heat (gas or steam).
2. **SERIAL NUMBER**— The serial number allows ADC to gather information on your particular dryer.
3. **MANUFACTURING CODE NUMBER**— The manufacturing code number is a number issued by ADC which describes all possible options on your particular model.
4. **TYPE OF HEAT**— Describes the type of heat; gas (natural or L.P.) or steam or electric.
5. **HEAT INPUT**— (For gas dryers) describes the heat input in British thermal units.

6. **ELECTRIC SERVICE**— Describes the electric service for your particular models.
7. **GAS MANIFOLD PRESSURE**— Describe the manifold pressure as taken at the gas valve pressure tap. (see **HOW TO USE A MANOMETER**)

## **B. USING A MANOMETER**

### **HOW TO USE A MANOMETER (ADC P/N: 122804)**

1. With dryer in non-operating mode remove plug on the gas valve pressure tap.
2. Attach plastic tubing to pressure tap. (Fitting is supplied with manometer see illustration.)
3. Attach manometer to dryer using magnet.

**NOTE:** Place manometer in a position so that readings can be taken at eye level.

4. Fill manometer as shown in illustration to the zero level.

5. Start dryer. With burner on take a reading.

A. Read water level at the inner tube.  
Readings should be taken at eye level.

B. Correct readings should be:

NATURAL GAS: 3.5 - 4.0 inches w.c.  
L.P. GAS: 11 - 10.5 inches w.c.

6. If water column pressure is incorrect refer to "TO ADJUST GAS PRESSURE"

7. Reverse procedure for removing manometer.

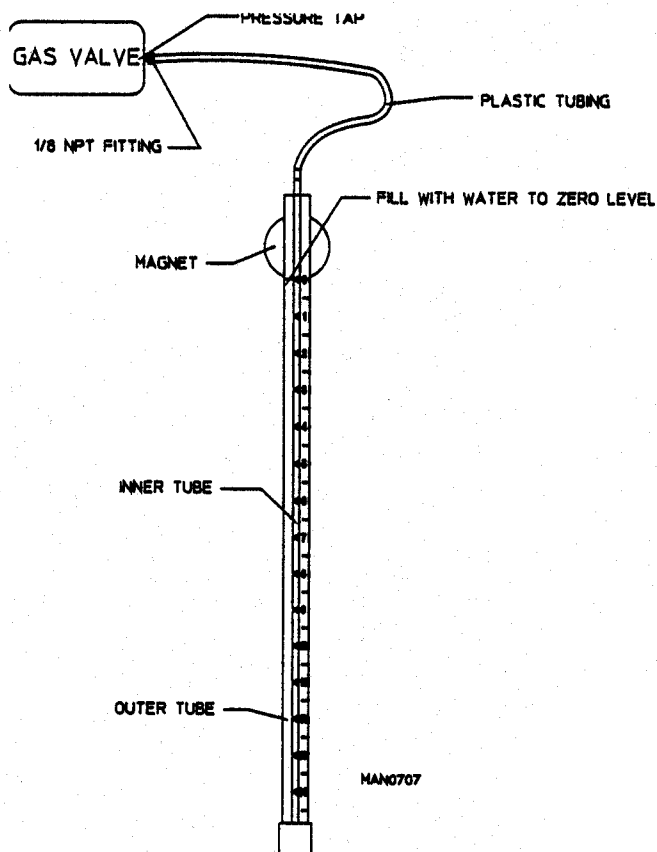

## C. L.E.D. DISPLAY CODES

<b>A</b>	Automatic Cycle (Slope Program Factor)
<b>ACOn</b>	Accumulative Coin
<b>Adrt</b>	Maximum Auto Dryness Time
<b>AFAt</b>	Amount for Additional Time
<b>AGt</b>	Active Anti-Wrinkle Guard Time
<b>AtIn</b>	Accumulative Time
<b>AtSt</b>	Amount Start
<b>AUtO</b>	Automatic Mode ( Patent No. 4,827,627)
<b>b</b>	Automatic Cycle (Heat loss [offset] Factor)
<b>bCLO</b>	Bad Coin Lockout
<b>bCrS</b>	Bad Coin Reset
<b>bUZ</b>	Buzzer (Tone)
<b>CEL</b>	Degree in Celsius
<b>CLCC</b>	Clear Left Coin Count
<b>COIn</b>	Coin Mode
<b>CrCC</b>	Clear Right Coin Count
<b>donE</b>	Drying and Cooling Cycles Complete
	or
	Dryer is in Anti-Wrinkle Cycle
<b>door</b>	Door Circuit is Open
<b>dSFL</b>	Dryer Sensor Circuit Failure
<b>FAr</b>	Degree in Fahrenheit
<b>FILL</b>	No Cycle in Progress
<b>FLS</b>	Flash Display Active
<b>FrEE</b>	Free Dry Mode
<b>GdLY</b>	Anti-Wrinkle Delay Time
<b>Gont</b>	Anti-Wrinkle On Time
<b>Grd</b>	Anti-Wrinkle Program Active
<b>HICd</b>	High Cool Down Temp
<b>Hot</b>	Overheating Condition
<b>LCC</b>	Left Coin Count
<b>LCde</b>	Left Coin Denomination
<b>LOCd</b>	Low Cool Down Temp
<b>nbUZ</b>	No Buzzer (Tone)
<b>nFLS</b>	No Flash Display
<b>Ngrd</b>	No Anti-Wrinkle
<b>nSEn</b>	Rotational Sensor Not Selected
<b>PdrY</b>	Percent Dry
<b>PL</b>	Program Location

<b>PLOC</b>	Program Location Automatic Review
<b>PP</b>	Permanent Press
<b>PUSH</b>	Amount to Start has been Inserted Make Temperature Selection
<b>rCC</b>	Right Coin Count
<b>rCdE</b>	Right Coin Denomination
<b>SEFL</b>	Rotational Sensor Circuit Failure
<b>SEn</b>	Rotational Sensor Selected
<b>tFAS</b>	Time for Amount to Start
<b>tInE</b>	Timed Mode

## D. COMPUTER LOGIC AND WIRING DIAGRAM

1. Operator inserts coin.
2. Operator enters desired selection (s)...
3. Information entered is sent to the Micro-Controller via the keyboard ribbon.
4. The input information is sorted / processed and executed by the Micro-Computer chip.

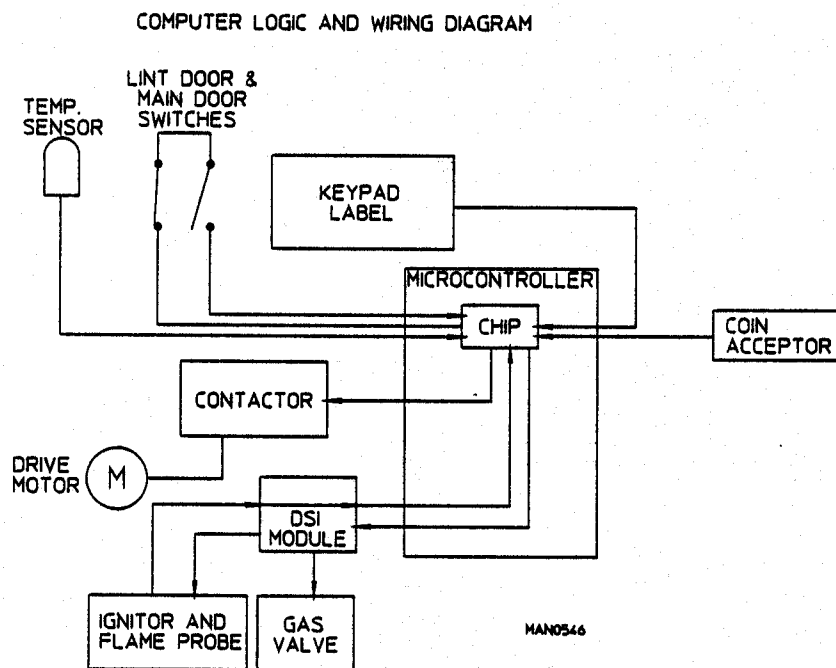

5. The micro-computer output signal activates the contactors and DSI module which controls the machines functions.

**NOTES:** When contacting American Dryer Corporation with electrical questions, please have on hand the correct wiring diagram number for your particular machine.

This number is located on the top right hand corner of the diagram. It is a six (6) digit number followed by a letter to distinguish the version dates (see illustration).

Your particular model will be different depending on the date of manufacturing and options available.

The correct wiring diagram for your machine is folded and placed inside of the computer area.

Diagrams for this book are as follows:  
(including all revisions of the number listed below)

B972611

Revision Number

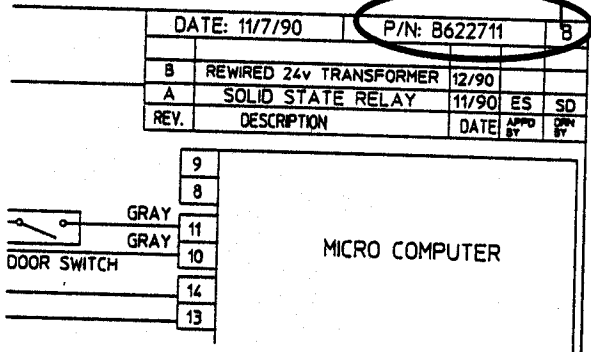

**ADC450161**

**1- 05/06/96-50**  
**4- 10/30/00-25**

**2- 06/10/96-100**

**3\* 08/15/96-100**



## Free Manuals Download Website

<http://myh66.com>

<http://usermanuals.us>

<http://www.somanuals.com>

<http://www.4manuals.cc>

<http://www.manual-lib.com>

<http://www.404manual.com>

<http://www.luxmanual.com>

<http://aubethermostatmanual.com>

Golf course search by state

<http://golfingnear.com>

Email search by domain

<http://emailbydomain.com>

Auto manuals search

<http://auto.somanuals.com>

TV manuals search

<http://tv.somanuals.com>