

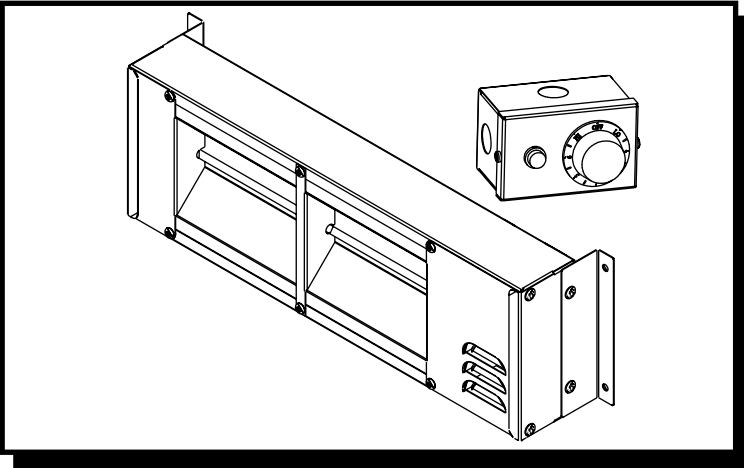

Model: **FD**
OVERHEAD WARMERS

INTENDED FOR OTHER THAN HOUSEHOLD USE

**INSTALLATION
AND
OPERATING
INSTRUCTIONS**



Northern

APW WYOTT® 54" Food Warmer has been designed for use only on the Metro® route stand. Each MetroR shelf has pre-drill holes to use with APW WYOTT® mounting bracket. Each warmer ships with pre-wired cord and plug. Remote controls are factory pre-wired and only have to be field mounted depending on route stand location. Follow the "Installation Instructions" (in this booklet) to mount controls.

**RETAIN THIS MANUAL FOR FUTURE REFERENCE
UNIT MUST BE KEPT CLEAR OF COMBUSTIBLES AT ALL TIMES**



FOR YOUR SAFETY: Do not store or use gasoline or other flammable vapors and liquids in the vicinity of this or any other appliance.



WARNING: Improper installation, adjustment, alteration, service or maintenance can cause property damage, injury or death. Read the Installation, Operating and Maintenance Instructions thoroughly before installing or servicing this equipment.



Initial heating of unit may generate smoke or fumes and must be done in a well ventilated area. Overexposure to smoke or fumes may cause nausea or dizziness.

This equipment has been engineered to provide you with year-round dependable service when used according to the instructions in this manual and standard commercial kitchen practices.

Phone: (214) 421-7366
Fax: (214) 565-0976
Toll Free: (800) 527-2100
Website: www.apwwyott.com
E-mail: info@apwwyott.com



APW / WYOTT
729 Third Avenue
Dallas, TX 75226

P/N 70402071 5/06

TABLE OF CONTENTS







SECTION	ITEM	PAGE
1	Owner's Information	3
	General Information.....	3
	Installation Instructions.....	3
	General Operation Instructions.....	6
	Warranty Information.....	6
2	Important Safety Information	6
3	Specifications	6
	Electrical.....	6
	Dimensions.....	7
4	Operation	8
	Operating Instructions.....	8
5	Cleaning	8
	General Cleaning Instructions.....	8
	Dominos Specific Cleaning Instructions.....	8
6	Troubleshooting	8
7	Parts List & Exploded View	9
8	Wiring Diagram	10
9	Warranty	11

1. OWNERS INFORMATION

General Information:

1. Always clean equipment thoroughly before first use. (See general cleaning instructions).
2. Check rating label for your model designation and electrical rating.
3. For best results, use stainless steel countertops.
4. All dimensions in parenthesis in centimeters unless noted.
5. APW Wyott Overhead Foodwarmers are constructed from high quality stainless steel and available in lengths from 18" to 72". Utilizing a metal sheath-heating element with a specially designed reflector, these units give uniform heat over the entire holding surface.
6. In Europe, contact an APW Wyott authorized service agency for replacement light bulbs.

Installation Instructions:

Hardware Provided for Installation of Food Warmer		
Quantity	Part Number	Description
4	88993	 Screw, 10-32x3/8 TRS HD Phillips
4	89071	 Washer, 10 Flat .5 OD x .218 ID
4	89062	 Nut, Hex 10-32
4	88904	 Screw, Rolock 8-32x3/8
4	89056	 Washer, #8 Internal Lock
4	88921	 Nut, 8-32 Acorn Cap

Domino's Specific Installations on Metro® Route Stands:

- A.** Remove food warmer and ceiling mounting brackets from packaging. Remove screws from ends of food warmer; attach ceiling mounting bracket at both ends of food warmer (as shown).

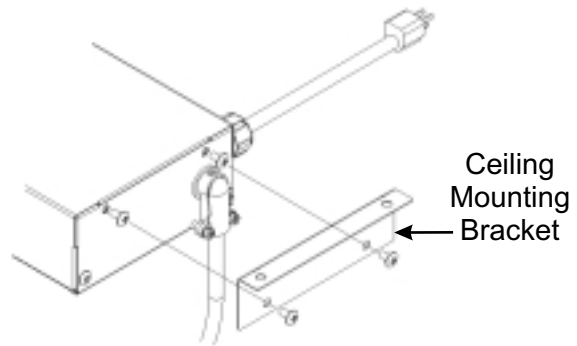

- B.** Use 88993 (screw), 89071 (washer), and 89062 (nut) to attach food warmer to underside of shelving. Place food warmer under shelf, aligning the ceiling mounting bracket holes with that of the shelf. May require two persons to hold food warmer in place. From the top of the shelf, push through the washer and screw. From the underside of the ceiling mounting bracket, screw the nut on. Repeat for other hole and holes at opposite end.

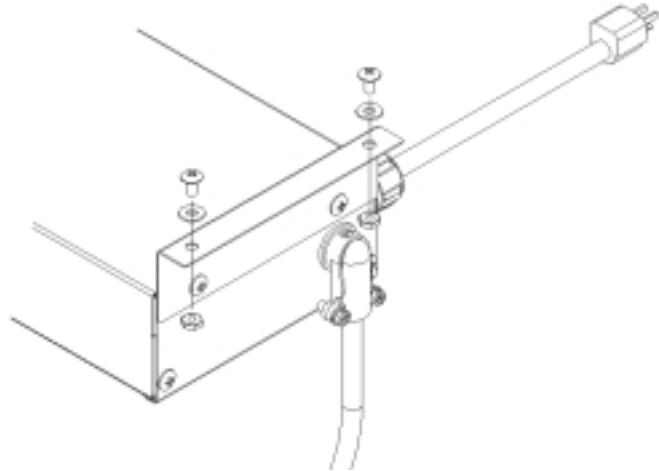

- C. Remote kit mounting.** There are two ways to mount the remote kit, front mounting and rear mounting. Front mounting is where the remote kit is mounted on the opposite side of the cord and plug. Rear mounting, the remote kit is mounted on the same side as the cord and plug. Whatever position chosen, when the food warmer is not operating (OFF), the knob on the remote box should be oriented where **OFF** is in the **north** position. The control is **NOT** designed to operate upside down. (Mount as shown below)

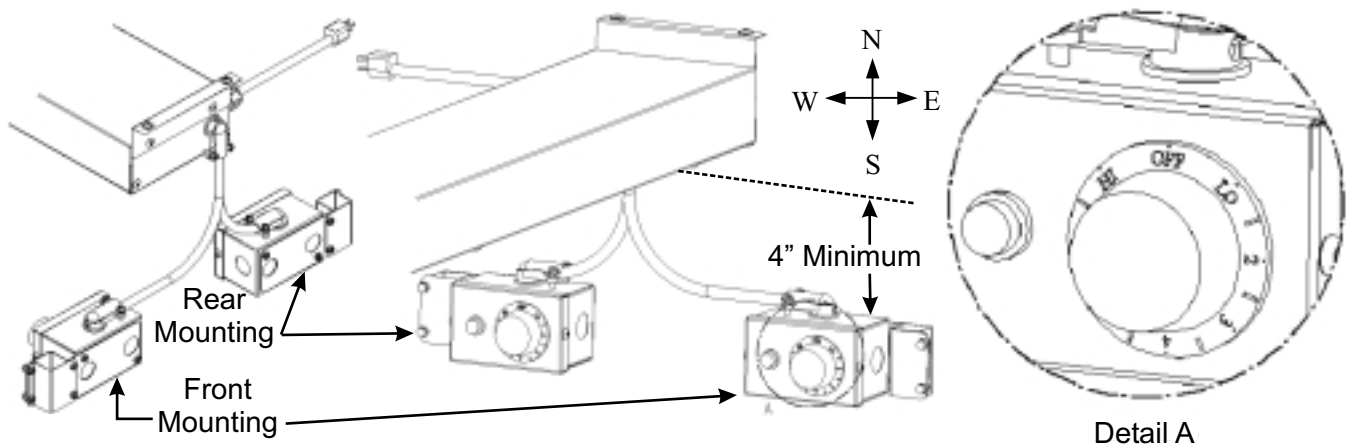

1. Use 88904 (screw), 89056 (washer), and 88921 (nut) to mount bracket. Place bracket (70402017) around shelving pole on the inner side of the shelving unit. Screw bracket (70402018) to bracket (70402017) around shelving pole on the outer side of the shelving unit. The bracket will allow the remote box inner side to align with the front side of the food warmer

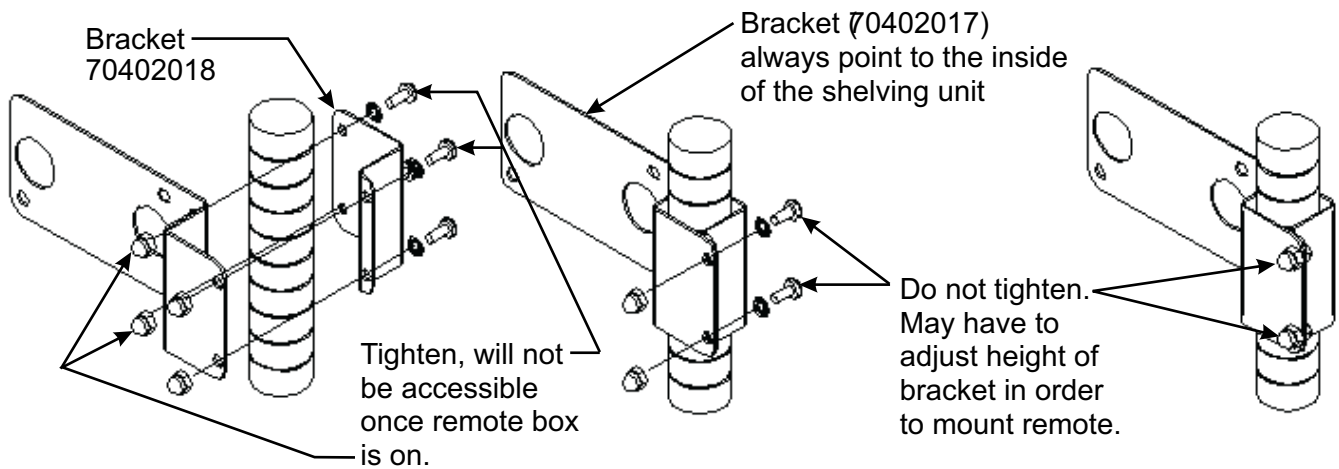

2. Remove screw and washer from remote box. Align the holes of the remote box with those of bracket 70402017. Screw the remote box to bracket 70402017. Once remote box is mounted to bracket, adjust height of the bracket so that the top of the remote box is even with or underneath the bottom of the side shields on the shelving unit (**min. distance 4"** between the bottom of heat strip and top of remote box) and tighten screws.

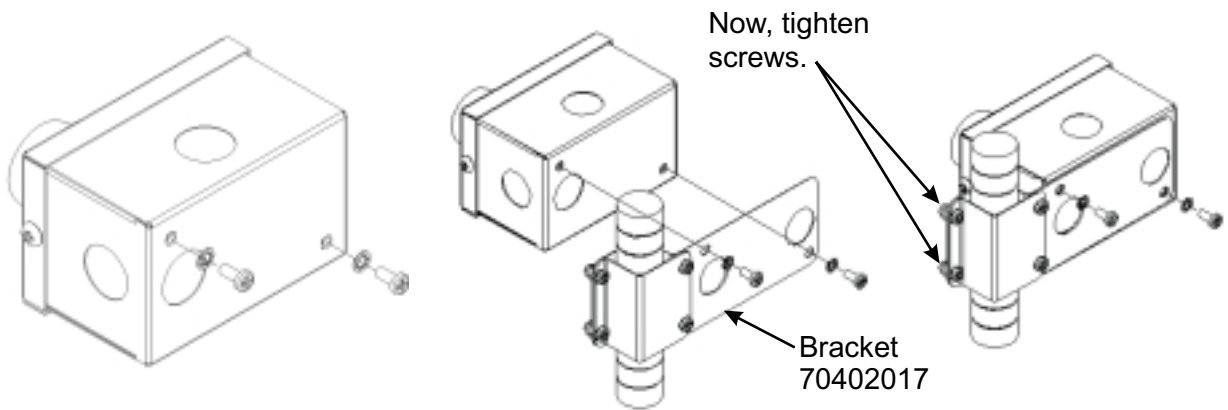

- D. Repeat steps A through C for other food warmers and shelving combination.

- E. Illustration of a complete Food warmer And Metro® Route stand unit



NOTE: TO AVOID BURNING OR CHARRING OF MATERIALS IN THE SURFACE BELOW THE FOODWARMER USE ONLY ABOVE AN ALL-METAL STRUCTURE SUCH AS A TABLE OR COUNTERTOP. **MINIMUM** CLEARANCE 13". FOR OTHER MATERIALS, INSTALL NOT CLOSER THAN 16" ABOVE THE SURFACE.



REMOTE SWITCHES ARE RECOMMENDED FOR UNDER SHELF MOUNTING. LONGER SWITCH LIFE WILL RESULT FROM COOLER SWITCH MOUNTING LOCATIONS.

General Operation Instructions:

1. All foodservice equipment should be operated by trained personnel.
2. Do not allow your customers to come in contact with any surface labeled "CAUTION HOT".
3. Where applicable: Never pour cold water into dry heated units.
4. Where applicable: Do not cook, warm or hold food directly in liner pans (well pans). Always use steamtable pans/insets, etc.
5. Never hold food below 150°F (66°C).

Warranty Information:

Reliability Backed By APW Wyott's Warranty:

All APW Wyott Holding Drawers are backed by a one year parts and labor warranty, including On-Site Service calls within 50 miles of authorized service technicians.

Service Information:

Service Hotline (800) 733-2203

2. SAFETY INFORMATION

APW Wyott Overhead Warmers are designed, built and sold for commercial use and should be operated by trained personnel only. Clearly post all CAUTIONS, WARNINGS and OPERATING INSTRUCTIONS near each unit to insure proper operation and to reduce the chance of personal injury and/or equipment damage.

Always disconnect power before servicing the Overhead Warmer. Surfaces will remain hot after power has been turned off. Allow unit to cool before cleaning or servicing. Never clean the Overhead Warmer by immersing it in water. The Overhead Warmer is not protected against water jets; DO NOT CLEAN OVERHEAD WARMER WITH A WATER JET. Always clean equipment before first use.

3. SPECIFICATIONS

Electrical:

- A. Single-phase operation at 120, 208, 230, and 240 volts.
- B. Field-wired units provided with 7/8" conduit hole, 6" long leads, and porcelain wire nuts. For supply connections, use minimum no. 14 AWG copper wires suitable for at least 90°C.
- C. U.S. cord-connected units provided with following plug configuration:
 1. 120 volt up to 1440 watts = NEMA 5-15P; 120 volt up to 1920 watts = NEMA 5-20P
 2. 208 volt up to 2496 watts = NEMA 6-15P; 208 volt up to 3328 watts = NEMA 6-20P
 3. 240 volt up to 2880 watts = NEMA 6-15P; 240 volt up to 3840 watts = NEMA 6-20P
- D. European cord-connected units provided with following plug configuration:
 1. Continental Europe 230 volt up to 3600 watts = Schuko CEE7/7
 2. UK 230 volt up to 2930 watts = Bs1363



WARNING: ELECTRICAL SHOCK HAZARD. FAILURE TO FOLLOW THE INSTRUCTIONS IN THIS MANUAL COULD RESULT IN SERIOUS INJURY OR DEATH.



- Electrical Ground is required on this appliance.
- Do not modify the power supply cord plug. If it does not fit into the outlet, have the proper outlet installed by a qualified electrician
- Do not use an extension cord with this appliance.
- Check with a qualified electrician if you are unsure as to whether the appliance is properly grounded.

Overall Dimensions:

FD MODELS

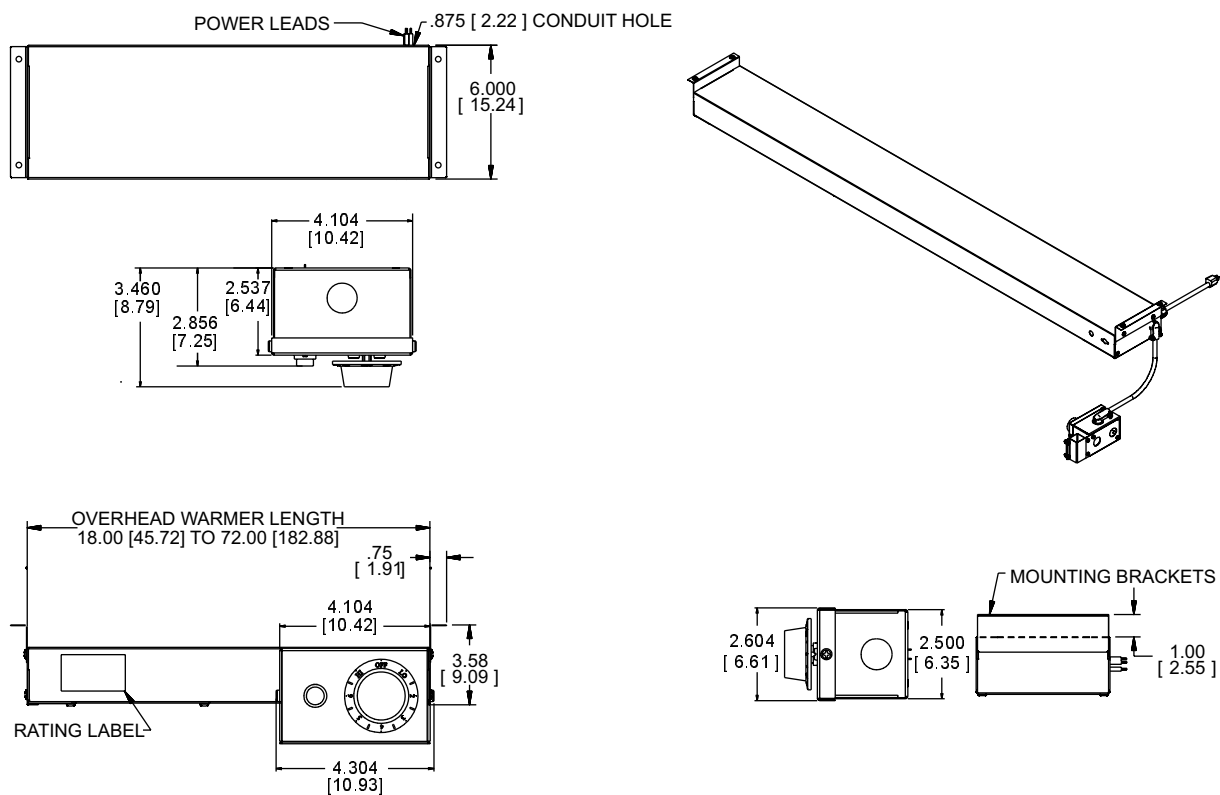

4. Operation

- A. All foodservice equipment should be operated by trained personnel.
- B. Do not allow your customers to come in contact with any surface labeled "CAUTION HOT".
- C. Switch on unit. Place precooked product under heat source. Maximum heat coverage equivalent to unit length.
- D. Never hold food below 150°F.

5. Cleaning

General Cleaning Instructions:

- A. Never clean any electrical unit by immersing it in water. Turn off before surface cleaning.
- B. Never clean any electrical unit using water jets.
- C. Disconnect power before cleaning or servicing units. All service should be performed by an APW authorized service agency.
- D. Clean unit daily. Use warm, soapy water. Mild cleansers and non-abrasive pads may be used to remove baked-on food.

Domino's Specific Cleaning Instructions:

- A. Follow general cleaning instructions in manual 57238 Section V for all units.
- B. For Domino's specific unit, remove mounting bracket 70402017 and 70402018. Clean any build-up on pole and brackets.

6. Troubleshooting

- A. Always ask and check:
 - 1. Is the unit connected to a live power source?
 - 2. Check the circuit breaker.
 - 3. Is the power switch on and pilot light illuminating?
 - 4. Check the rating label. Is the unit operating on proper voltage?
- B. If the above checks out, and problems still exist, call an APW Wyott authorized service agency.
- C. All service should be performed by an APW Wyott authorized service agency.

7. FD PARTS LIST w/Exploded View

ITEM #	PART #	DESCRIPTION	QTY	ITEM #	PART #	DESCRIPTION	QTY
1	76841	HOUSING W/ASSY FD54 RH CTRL	1	21	70402017	BRACKET, FD REMOTE DOMINOS	1
2	89059	WASHER #10 EXTERNAL LOCK	2	22	55343	CONDUIT CONNECTOR, 90° FLEX	2
3	88961	NUT, HEX 10-24, GREEN	1	23	70402022	CONDUIT, 1/2"	1
4	57718	END PLATE FD	1	24	89062	NUT HEX 10-32	4
5	89071	WASHER, #10 FLAT	5	25	55340	BUSHING, ANTI-SHORT CCD, #1	2
6	76811	REFLECTOR FD54	1	26	76190	INSULATION 18-72	2
7	75863	ELEMENT, 925W - 120V	1	27	70402018	BRACKET, FD REMOTE DOMINOS	1
8	76801	COVER LARGE FD RH CTRL	1	28	70402024	REMOTE KIT, 1 INFINITE 120V	1
9	76802	COVER SMALL FD	1	29	88904	SCREW, 8-32 X 3/8 PAN HD	6
10	76106	ELEMENT GUARD FD	2	30	89056	WASHER #8 INT LOCK, SS	6
11	76955	BRACKET MOUNTING FD	2	31	88921	NUT, ACORN CAP 8-32 SS	4
12	58004	FASTENER SELF RETAINING	1	32	55941	CORDSET ASSY, 14GA.	1
13	88889	SCREW #8 X 1/2 AB SMS PHL	9	33	76191	INSULATION 18-72	1
14	88993	SCREW 10-32X3/8 TRS HD PHL	12	34	56530	LIGHT, PILOT	1
15	76189	INSULATION 1/2 X 6 X 2-1/2 FD18-72	2	35	88904	SCREW, 8-32 x 3/8 PAN HEAD	2
16	70402028	INSULATION 18-72	1	36	55564-EGO	INFINITE SWITCH-EGO	1
17	76803	END PLATE FD	1	37	89087	SCREW, 8-32 x 3/16 BINDING HEAD	2
18	76804	SUPPORT ELEMENT FD	2	38	55825	KNOB, INFINITE NO LOGO	1
19	89129	STRAIN RELIEF, CONNECTOR	1	39	70402026	REMOTE ENCLOSURE, SINGLE CONTROL	1
20	55102	NUT, LOCK ELEC BUSHING	1				

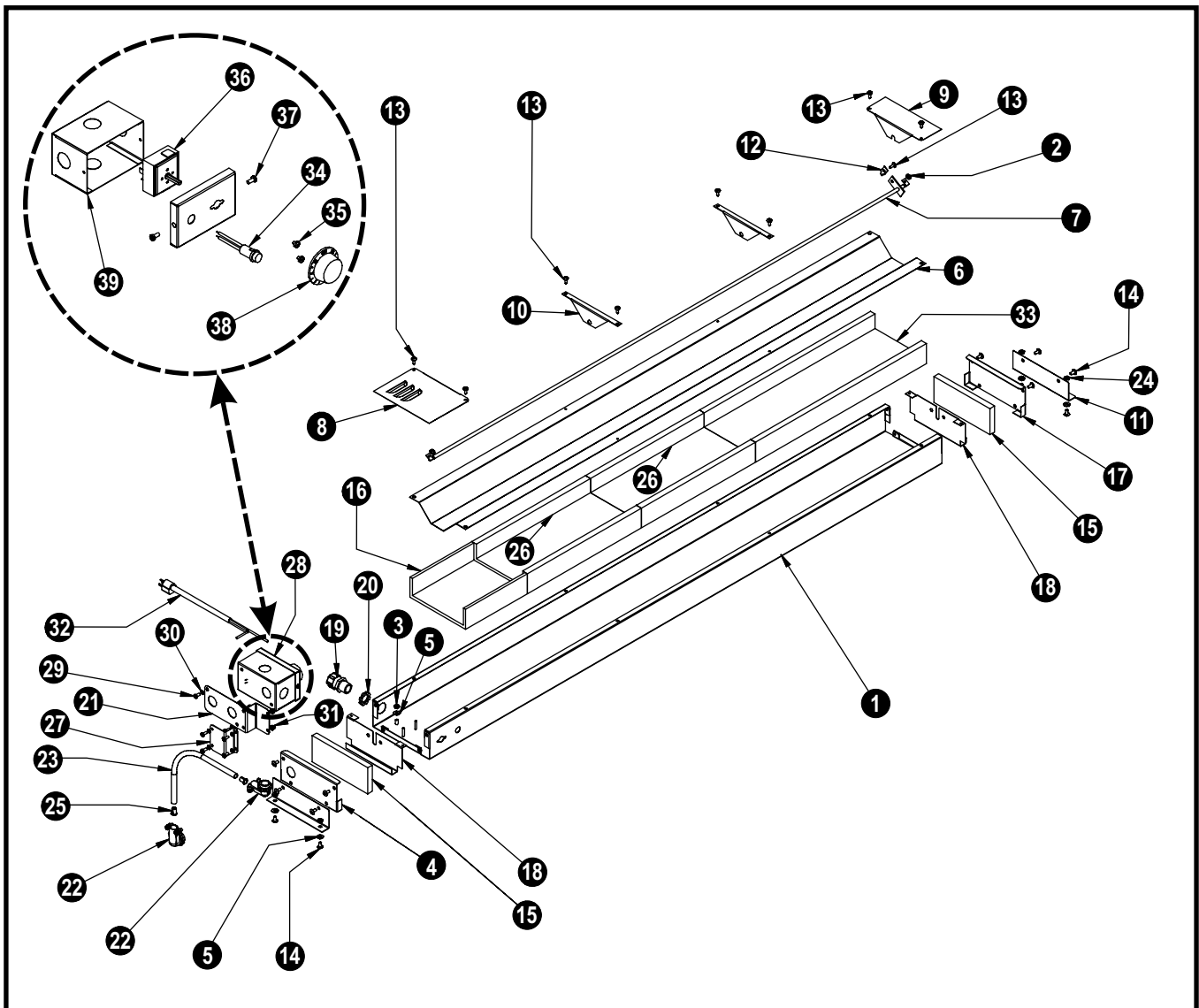

8. FD18-72 WIRING DIAGRAMS

REMOTE CONFIGURATION

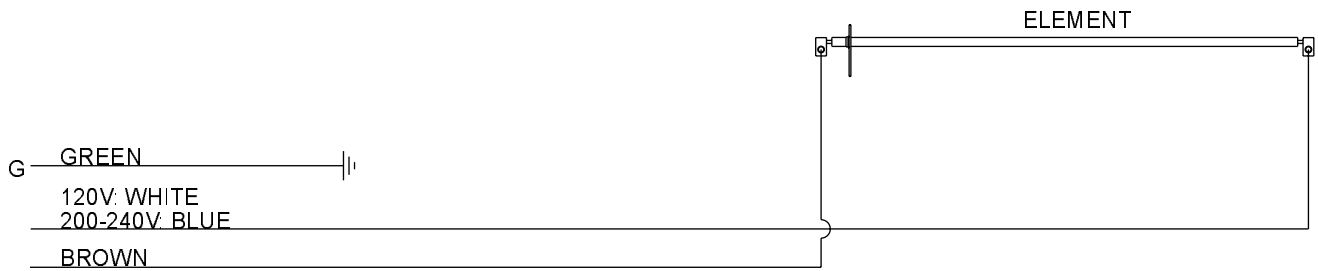

INFINITE CONTROL CONFIGURATION

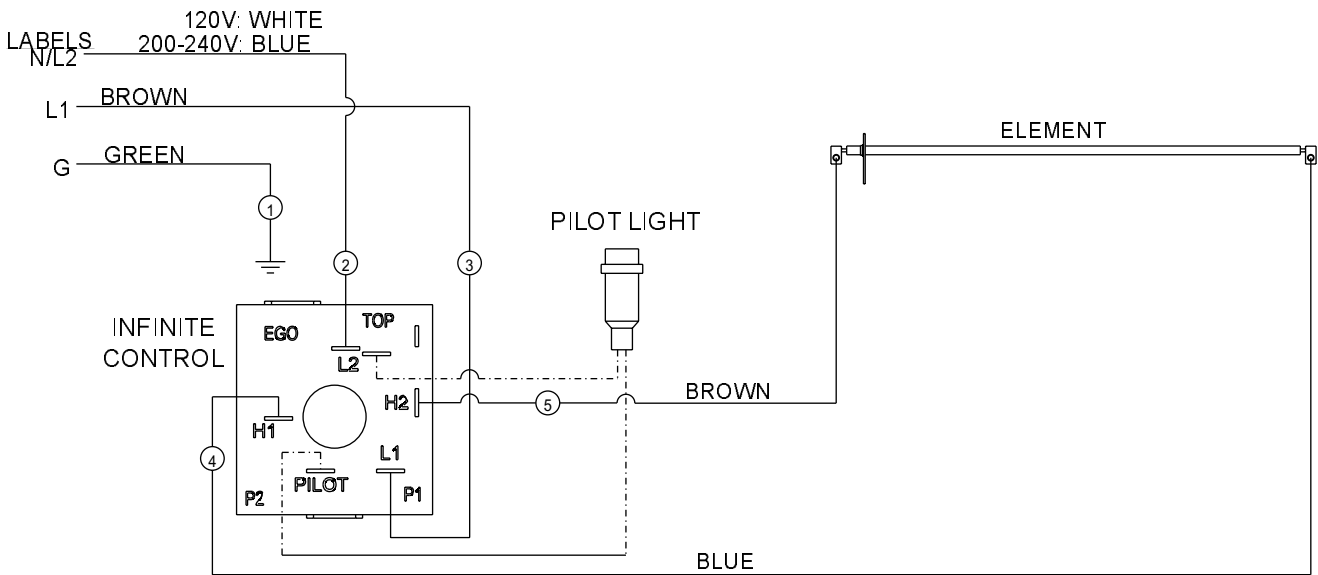

9. APW WYOTT EQUIPMENT LIMITED WARRANTY

APW Wyott Foodservice Equipment Company warrants its equipment against defects in materials and workmanship, subject to the following conditions:

This warranty applies to the original owner only and is not assignable.

Should any product fail to function in its intended manner under normal use within the limits defined in this warranty, at the option of APW Wyott such product will be repaired or replaced by APW Wyott or its Authorized Service Agency. APW Wyott will only be responsible for charges incurred or service performed by its Authorized Service Agencies. The use of other than APW Wyott Authorized Service Agencies will void this warranty and APW Wyott will not be responsible for such work or any charges associated with same. The closest APW Wyott Authorized Service Agent must be used.

This warranty covers products shipped into the 48 contiguous United States, Hawaii, metropolitan areas of Alaska and Canada. There will be no labor coverage for equipment located on any island not connected by roadway to the mainland.

Warranty coverage on products used outside the 48 contiguous United States, Hawaii, and metropolitan areas of Alaska and Canada may vary. Contact the international APW Wyott distributor, dealer, or service agency for details.

Time Period

One year for parts and one year for labor, effective from the date of purchase by the original owner. The Authorized Service Agency may, at their option, require proof of purchase. Parts replaced under this warranty are warranted for the un-expired portion of the original product warranty only.

Exceptions

***Gas/Electric Cookline:** Models GCB, GCRB, GF, GGM, GGT, CHP-H, EF, EG, EHP. Three (3) Year Warranty on all component parts, except switches and thermostats. (2 additional years on parts only. No labor on second or third year.)

***Broiler Briquettes, Rock Grates, Cooking Grates, Burner Shields, Fireboxes:** 90 Day Material Only. No Labor.

***Heat Strips:** Models FD, FDL, FDD, FDDL. Two (2) Year Warranty on element only. No labor second year.

***Glass Windows, Doors, Seals, Rubber Seals, Light Bulbs:** 90 Day Material Only. No Labor.

In all cases, parts covered by extended warranty will be shipped FOB the factory after the first year.

Portable Carry In Products

Equipment weighing over 70 pounds or permanently installed will be serviced on-site as per the terms of this warranty. Equipment weighing 70 pounds or under, and which is not permanently installed, i.e. with cord and plug, is considered portable and is subject to the following warranty handling limitations. If portable equipment fails to operate in its intended manner on the first day of connection, or use, at APW Wyott's option or its Authorized Service Agency, it will be serviced on site or replaced.

From day two through the conclusion of this warranty period, portable units must be taken to or sent prepaid to the APW Wyott Authorized Service Agency for in-warranty repairs. No mileage or travel charges are allowed on portable units after the first day of use. If the customer wants on-site service, they may receive same by paying the travel and mileage charges. Exceptions to this rule: (1) countertop warmers and cookers, which are covered under the Enhanced Warranty Program, and (2) toasters or rollergrills which have in store service.

Exclusions

The following conditions are not covered by warranty:

*Equipment failure relating to improper installation, improper utility connection or supply and problems due to ventilation.

*Equipment that has not been properly maintained, calibration of controls, adjustments, damage from improper cleaning and water damage to controls.

*Equipment that has not been used in an appropriate manner, or has been subject to misuse or misapplication, neglect, abuse, accident, alteration, negligence, damage during transit, delivery or installation, fire, flood, riot or act of god.

*Equipment that has the model number or serial number removed or altered.

If the equipment has been changed, altered, modified or repaired by other than an Authorized Service Agency during or after the warranty period, then the manufacturer shall not be liable for any damages to any person or to any property, which may result from the use of the equipment thereafter.

This warranty does not cover services performed at overtime or premium labor rates. Should service be required at times which normally involve overtime or premium labor rates, the owner shall be charged for the difference between normal service rates and such premium rates. APW Wyott does not assume any liability for extended delays in replacing or repairing any items beyond its control.

In all cases, the use of other than APW Wyott Authorized OEM Replacement Parts will void this warranty.

This equipment is intended for commercial use only. Warranty is void if equipment is installed in other than commercial application.

Water Quality Requirements

Water supply intended for a unit that has in excess of 3.0 grains of hardness per gallon (GPG) must be treated or softened before being used. Water containing over 3.0 GPG will decrease the efficiency and reduce the operation life of the unit.

Note: Product failure caused by liming or sediment buildup is not covered under warranty.

"THE FOREGOING WARRANTY IS IN LIEU OF ANY AND ALL OTHER WARRANTIES EXPRESSED OR IMPLIED INCLUDING ANY IMPLIED WARRANTY OF MERCHANTABILITY OR FITNESS FOR PARTICULAR PURPOSES AND CONSTITUTES THE ENTIRE LIABILITY OF APW WYOTT. IN NO EVENT DOES THE LIMITED WARRANTY EXTEND BEYOND THE TERMS STATED HEREIN."

9/05



Phone: (214) 421-7366
Fax: (214) 565-0976
Toll Free: (800) 527-2100
Website: www.apwwyott.com
E-mail: info@apwwyott.com

APW WYOTT
729 Third Avenue
Dallas, TX 75226

Free Manuals Download Website

<http://myh66.com>

<http://usermanuals.us>

<http://www.somanuals.com>

<http://www.4manuals.cc>

<http://www.manual-lib.com>

<http://www.404manual.com>

<http://www.luxmanual.com>

<http://aubethermostatmanual.com>

Golf course search by state

<http://golfingnear.com>

Email search by domain

<http://emailbydomain.com>

Auto manuals search

<http://auto.somanuals.com>

TV manuals search

<http://tv.somanuals.com>